

N88-11146

THE LEWIS STRAIN GAUGE LABORATORY - STATUS AND PLANS

Howard F. Hobart and Herbert A. Will
NASA Lewis Research Center
Cleveland, Ohio

Several recent and ongoing HOST programs have the goal of developing electrical resistance strain gauge systems for measuring static strain in the hot-section components (combustors and turbine blades and vanes) of gas-turbine engines. A typical goal is to be able to measure static strain up to ± 2000 microstrain to within ± 10 percent at temperatures to 1250 K over a 50-hr period.

The approach to the problem has been to first develop an alloy with suitable high-temperature characteristics. Once a suitable alloy has been identified, gauges made of sputtered thin films or small diameter (0.025 mm) wire will be fabricated and evaluated.

The ongoing HOST programs are a combination of parallel in-house and contract work to achieve these goals. An in-house lab has been established for developing, testing, and evaluating high-temperature strain gauges and to aid in in-house applications of high-temperature strain instrumentation. To accomplish these tasks, data must be taken over a wide range of temperatures, times, and strain levels. If done manually, this becomes a very labor-intensive effort; therefore, the lab is automated to provide computer control of oven temperatures, imposed strain, and data sampling.

Test Apparatus

The basic equipment of the lab consists of two ovens, a test fixture for holding a constant strain beam, an actuator for deflecting the beam, and a computer controller and data system. One oven is dedicated to the test fixture. The computer-controlled actuator is mounted at the rear of the oven and deflects the beam via an extension rod. This system allows determination of gauge factor at various strain levels and temperatures all under computer control. The second oven is presently set up with a holding-cooling fixture to support an in-house experiment in the burner cyclic rig (ref. 1). Both ovens have been modified by the addition of an air mixer to eliminate temperature gradients.

Computer Controller and Data System

A standard IBM PC is set up as a system controller and data collector for the testing of high-temperature strain gauges. A block diagram of the strain gauge testing system is shown in figure 1.

The testing system consists of a 10-channel digital thermometer, a 2-channel digital-to-analog converter in programming the oven temperatures, a digital multimeter for measuring strain gauge resistance, a single-axis linear actuator for mechanically bending the strain gauge beam, and a 10-channel strain gauge bridge for measuring strain directly. The computer communicates with the strain gauge instrumentation by means of an IEEE-488 bus and an RS-232 serial interface.

The computer program (written in Fortran 77) is a very versatile time-sequencing controller. The operator can control each instrument by putting a series of times and commands in a dataset. The computer program then controls the instruments according to this series of commands. Commands are written in any order in an easy to understand English language format.

Currently, the program records data from the instruments and prints it out on a sheet of paper. In the future the data will be recorded on a floppy disk for analysis by other computer programs.

Lab Status and Future Plans

Today the strain gauge laboratory, is nearly operational. The computer control program is operational, with only a few minor bugs.

Several tests will be conducted in the near future. One involves characterizing strain gauges mounted on a Hastelloy X plate. Four Chinese-type gauges (ref. 2) and four Kanthal A-1 wire gauges (ref. 3) will be used in this in-house experiment on combustor simulation. The other test is related to a contractor effort to develop gauge systems from a palladium - 13-weight-percent-chromium alloy (ref. 4); NASA has ordered 0.025-mm-diameter wire for winding gauges of this material. Also, a sputtering target of Pd-Cr is in use to develop in-house expertise in the thin film sputtering area.

The strain gauge laboratory as designed is expected to perform these types of automated tests to yield maximum data with minimum manpower expended.

REFERENCES

1. Thompson, Robert L.: High Temperature Stress-Strain Analysis. Turbine Engine Hot Section Technology 1984, NASA CP-2339, 1984, pp. 259-272.
2. Hobart, Howard F.: Evaluation Results of the 700 °C Chinese Strain Gages. Turbine Engine Hot Section Technology 1984, NASA CP-2339, 1984, pp. 77-84.
3. Grant, Howard P.; Anderson, Wilbur L.: Demonstration Test of Burner Liner Strain Measurements Using Resistance Strain Gages. Turbine Engine Hot Section Technology 1984, NASA CP-2339, 1984, pp. 85-100.
4. Hulse, Charles; Bailey, Richard; Grant, Howard: High Temperature Static Strain Gage Program. Turbine Engine Hot Section Technology 1984, NASA CP-2339, 1984, pp. 71-76.

STRAIN GAUGE TESTING SYSTEM

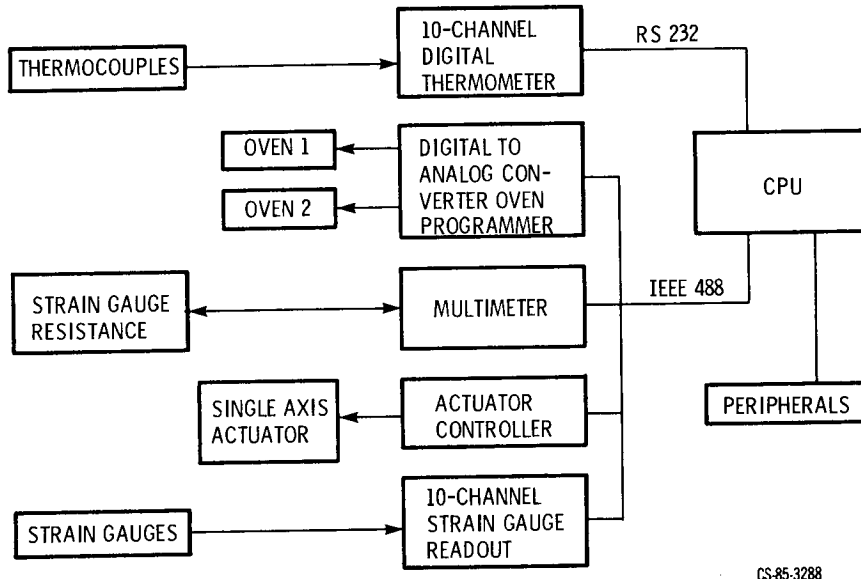

Figure 1