

N88-11165

3-D INELASTIC ANALYSIS METHODS
FOR HOT SECTION COMPONENTS*E. S. Todd
United Technologies Corporation
Pratt & Whitney

The objective of this program is to produce a series of new computer codes that permit more accurate and efficient three-dimensional inelastic structural analysis of combustor liners, turbine blades, and turbine vanes. Each code embodies a progression of mathematical models for increasingly comprehensive representation of the geometrical features, loading conditions, and forms of nonlinear material response that distinguish these three groups of hot section components.

Software in the form of stand-alone codes is being developed by Pratt & Whitney (P&W) with assistance from three uniquely qualified subcontractors: MARC Analysis Research Corporation (MARC), United Technologies Research Center (UTRC), and the State University of New York at Buffalo (SUNY-B). Special finite element models are being constructed by MARC, while mechanics of materials models and constitutive models are being assembled by UTRC. Development of advanced formulation (boundary element) models is being shared by P&W and SUNY-B. Verification of the various analysis packages is being done by P&W.

The technical effort of the Inelastic Analysis Methods program is divided into two 24-month segments: a base program, and an optional program exercised at the discretion of the government. The first year (Task I) of the base program dealt with linear theory in the sense that stresses or strains and temperatures in generic modeling regions are linear functions of the spatial coordinates, and solution increments for load, temperature and/or time are extrapolated linearly from previous information. The second half of the base program (Task II), as well as the option program (Tasks IV and V), extend the models to include higher-order representations of deformations and loads in space and time and deal more effectively with collections of discontinuities such as cooling holes and coating cracks. Work on Task II (polynomial theory) has been completed, and the results are given in the Second Annual Status Report (ref. 1). Base program computer codes, hereafter referred to as MOMM (Mechanics of Materials Model), MHOST (MARC-HOST), and BEST (Boundary Element Stress Technology), have been developed and delivered to NASA-Lewis Research Center.

Three increasingly sophisticated constitutive models are employed by MOMM, MHOST, and BEST to account for inelastic material behavior (plasticity, creep) in the elevated temperature regime. The simplified model assumes a bilinear approximation of stress-strain response and glosses over the complications associated with strain rate effects, etc. The state-of-the-art model partitions time-independent (plasticity) and time-dependent (creep) in the conventional way, invoking the Von Mises yield criterion and standard (isotropic, kinematic, combined) hardening rules for the former, and a power law for the latter. Walker's viscoplasticity theory (ref. 2), which accounts for the interaction between creep/relaxation and plasticity that occurs under cyclic loading conditions, has been adopted as the advanced constitutive model.

*Work done under NASA Contract NAS3-23697.

In brief, MOMM is a stiffness method finite element code that utilizes one-, two- and three-dimensional arrays of beam elements to simulate hot section component behavior. Despite limitations of such beam model representations, the code will be useful during early phases of component design as a fast, easy to use, computationally efficient tool. All of the structural analysis types (static, buckling, vibration, dynamics), as well as the three constitutive models mentioned above, are provided by MOMM. Capabilities of the code have been tested for a variety of simple problem discretizations (ref. 1).

The MHOST code employs both shell and solid (brick) elements in a mixed method framework to provide comprehensive capabilities for investigating local (stress/strain) and global (vibration, buckling) behavior of hot section components. Over the last decade, in order to support their commercially available software, the MARC Corporation has accumulated a great deal of technical expertise creating new, improved algorithms that will significantly reduce CPU (central processing unit) time requirements for three-dimensional analyses. The MHOST code development has taken advantage of this expertise. Second generation (Task II) MHOST code is operational and has been tested with a variety of academic as well as engine-related configurations (ref. 1).

Successful assembly of the all-new BEST code was possibly the most important accomplishment of the base program effort. The challenge of extending basic theory and algorithms to encompass inelastic dynamic effects in three-space was met by combining the special skills and efforts of the research and programming teams at SUNY-B and P&W. As with MOMM and MHOST, the second version of BEST is executable and has been exercised with both small and large test cases (ref. 1). While MHOST and BEST are currently viewed as complementary, they are also competitors; and overall performance on large inelastic models will be watched with interest as the codes mature.

Experimental data from the Benchmark Notch Test program (ref. 3) are being used to verify the stress analysis capabilities of the Inelastic Methods codes. Nominal dimensions of the benchmark notch specimen are shown in figure 1. Finite element and boundary element meshes for one-quarter of the specimen gage section are shown in figure 2. Measured notch root stress-strain behavior for initial uploads of several specimens is summarized in figure 3. Correlation between the MHOST predictions and the measured strains is very good (fig. 4). Simulation of first-cycle notch root behavior with BEST has also proven to be quite accurate (fig. 5).

Work on Task IV (special functions theory) and application of the codes to representative turbine blade and vane configurations is in process, and will be described at the Fourth Annual HOST Workshop.

REFERENCES

1. Wilson, R. B.; Bak, M. J.; Nakazawa, S., and Banerjee, P. K.: "3-D Inelastic Analysis Methods for Hot Section Components (Base Program): Second Annual Status Report" (Draft), March 1985.
2. Walker, K. P.: "Research and Development Program for Nonlinear Structural Modeling With Advanced Time-Temperature Dependent Constitutive Relationships," NASA CR-165533, November 25, 1981.
3. Domas, P. A.; Sharpe, W. N.; Ward, M.; and Yau, J.: "Benchmark Notch Test for Life Prediction," NASA CR-165571, June 1982.

Benchmark Notch Specimen

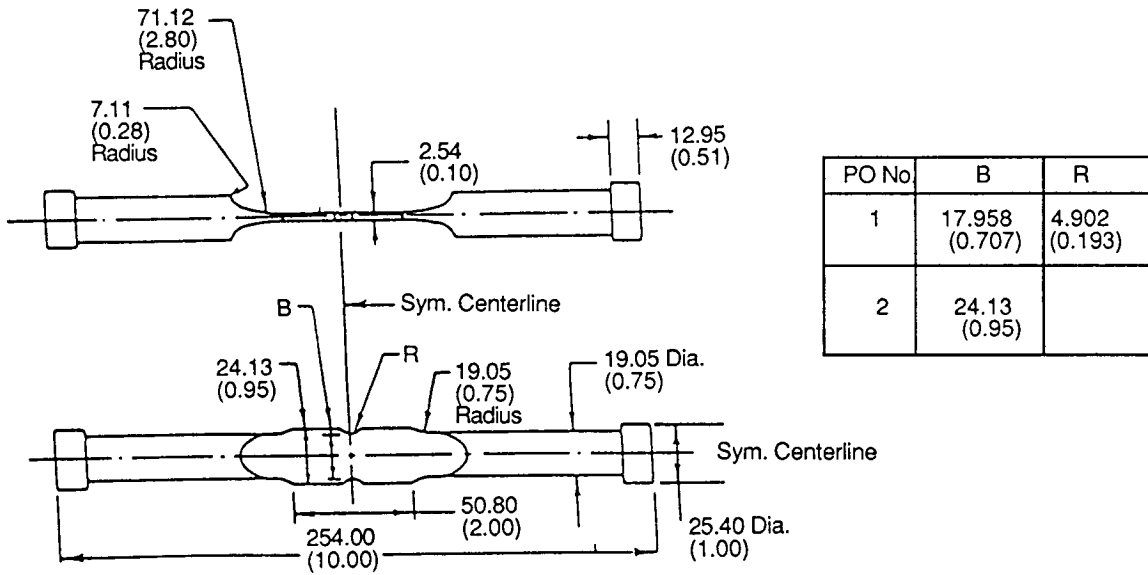

Dimensions in mm (inches)

Figure 1

Meshes Used In Benchmark Notch Analysis

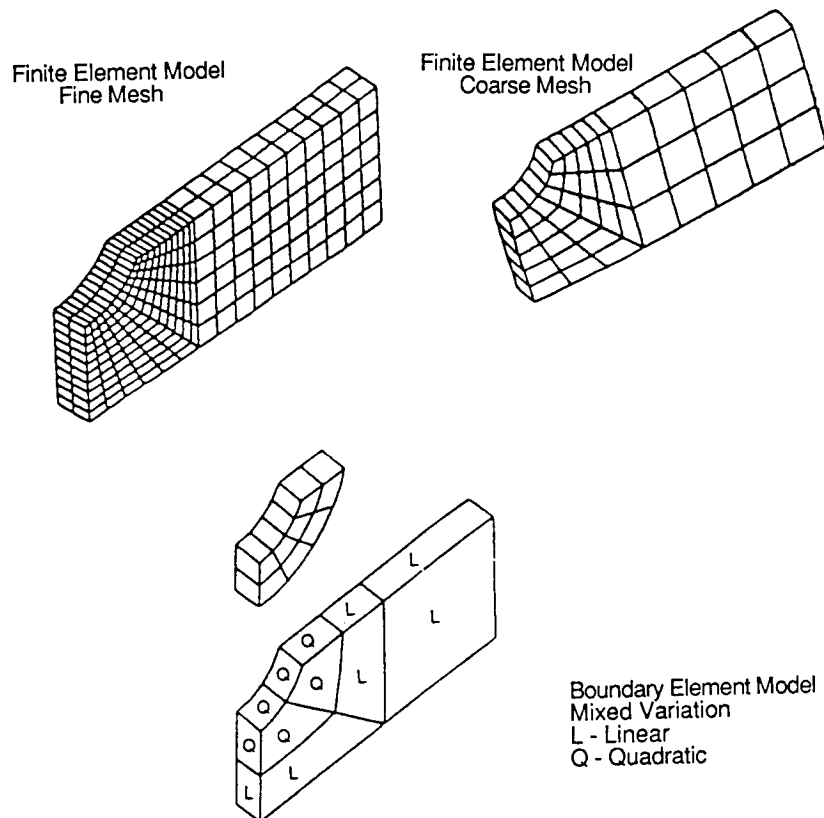

Figure 2

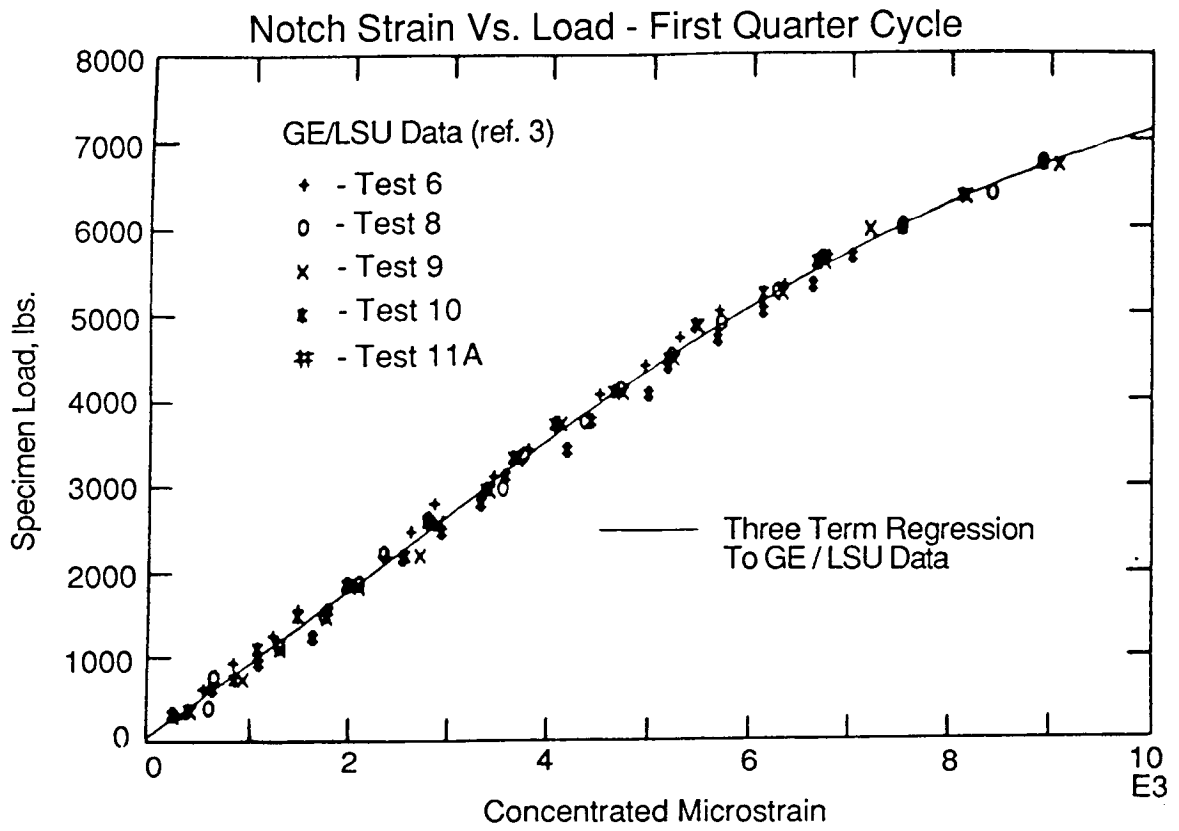

Figure 3

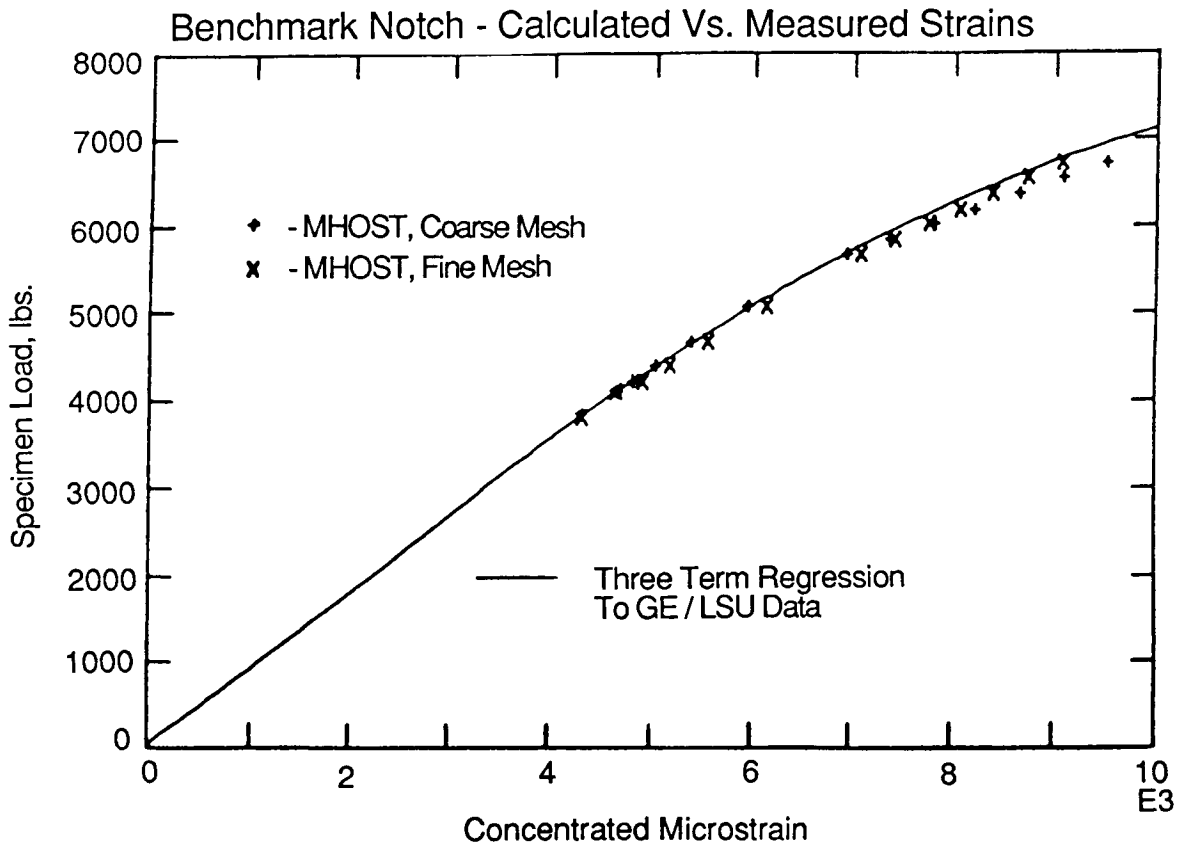

Figure 4

Cyclic Behavior At Root Of Specimen Notch

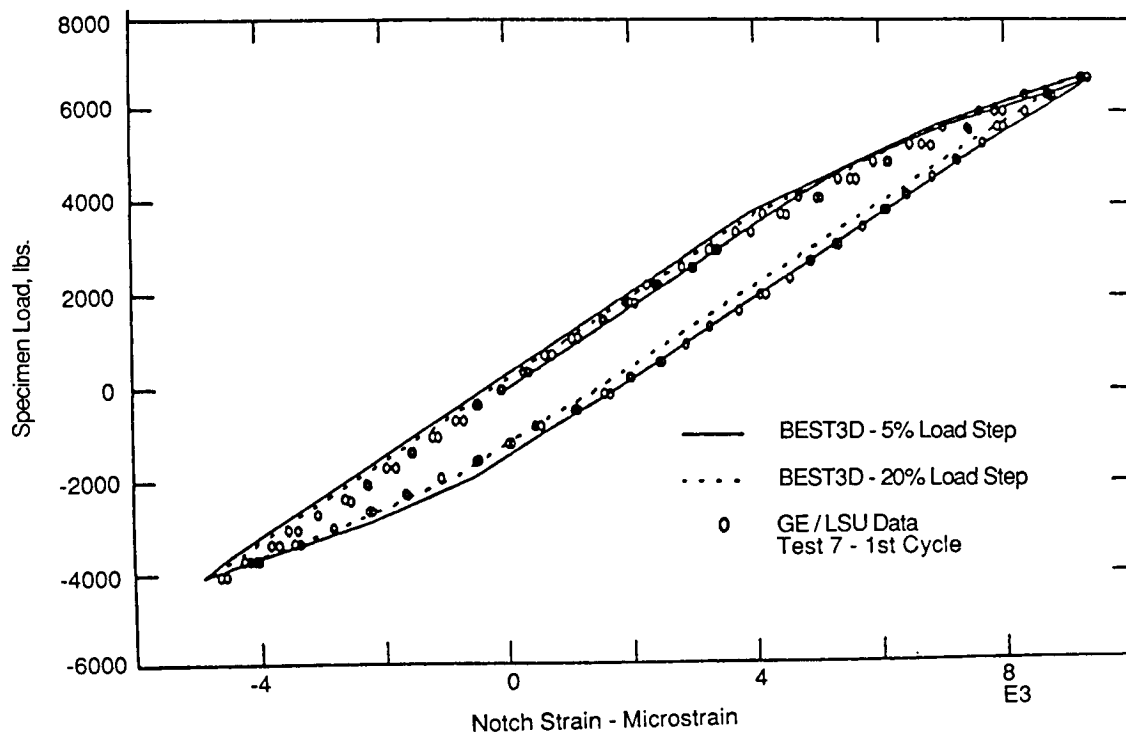

Figure 5