

NASA Technical Memorandum 100229

Photovoltaic Power Modules for NASA's Manned Space Station

{NASA-TM-100229} PHOTOVOLTAIC POWER MODULES
FOR NASA'S MANNED SPACE STATION {NASA} 13
p Avail: NTIS HC A03/MF A01 CSCL 10C

N88-11745

Unclas
G3/20 0107317

Charles A. Tatro
Lewis Research Center
Cleveland, Ohio

Prepared for the
1988 Solar Energy Conference
sponsored by the American Society of Mechanical Engineers
Golden, Colorado, April 10-14, 1988

NASA

PHOTOVOLTAIC POWER MODULES FOR NASA'S MANNED SPACE STATION

Charles A. Tatro
National Aeronautics and Space Administration
Lewis Research Center
Cleveland, Ohio 44135

ABSTRACT

The capability and the safety of manned spacecraft are largely dependent upon reliable electric power systems. Two similar space power systems able to survive the low-earth orbit environment, are being considered for NASA's Manned Space Station (SS), scheduled to begin operation in the mid 1990's. The Space Station Electric Power System (EPS) is composed of Photovoltaic (PV) Power Modules, Solar Solar Dynamic (SD) Power Modules, and the Power Management and Distribution (PMAD) System. One EPS configuration will deliver 37.5 kW of PV-based, utility-grade, ac power to SS users. A second 75 kWe PV-based EPS option is also being considered for SS deployment. The two EPS options utilize common modules and differ only in the total number of PV Power Modules used. Each PV Power Module supplies 18.75 kWe of ac power and incorporates its own energy storage and thermal control. The focus of this paper is on the general requirements and the current preliminary design configuration of the Space Station PV Power Modules.

INTRODUCTION

The NASA Lewis Research Center is responsible for design, development, testing, evaluation, and integration (DDT & EI) of the Electrical Power System (EPS) for the Space Station (SS) and for the Polar and Co-orbiting Platforms. The two EPS development options being considered are listed in Table I. A single EPS option will be selected for development before 1988, probably the 75 kWe PV option. Both options utilize 18.75 kWe Photovoltaic (PV) Power Modules as integral components of the SS EPS. Total power capability will be a function of the number of PV Power Modules placed on the station. Solar Dynamic (SD) Power Modules will provide 50 kWe of ac power in either option. Both SS EPS options allow for future growth capability to 300 kWe of usable ac power.

The SS EPS consists of three types of elements. These elements are: PV Power Modules, SD Power Modules, and the Power Management and Distribution (PMAD) System. Two SD Power Modules and either two or four PV Power Modules (depending on the EPS option chosen) will supply SS electrical power. These power modules interface with the SS via the PMAD System, which provides overall SS EPS control. Each power module (PV or SD) contains its own energy storage system, its own thermal control, and some autonomous control features.

Initially, 37.5 kWe of utility-grade, ac power will be provided to SS users from two, 18.75 kWe PV power modules located on outboard sections of the station's central structure, as shown at the top of Fig. 1. Additional PV Modules will then be added to increase EPS capability to 75 kWe (assuming this option is selected) as shown at the bottom of Fig. 1. This 75 kWe all-PV system represents the culmination of Phase I development for the SS EPS. PV power generation was chosen over SD, for this initial phase, because of its low technical and performance risk. The final operating configuration (Phase II) utilizes two additional 25 kWe SD Modules to provide 125 kWe and is shown in Fig. 2.

PV power generation and storage components are also being developed for the Polar and Co-orbiting Platforms. These platforms utilize PV module hardware that is common with the SS, although the size and total number of solar array panels and the number of NiH₂ cells per battery is reduced.

SS assembly will begin in 1994 with the launch of the EPS PV power modules and associated station hardware. The PV power modules will be assembled in low earth orbit (LEO) from modular components carried aloft by the Space Shuttle Orbiter. The SS will be placed in LEO between 180 and 250 n mi (330 and 458 km) above the earth's surface at an orbital inclination of 28.5°. This orbit provides roughly 60 min of direct insolation and 36 min of eclipse over an orbital period of ~96 mi.

THE PV POWER MODULES

Each PV power module delivers 18.75 kWe average ac power per orbit to SS users and weighs ~12 800 lb (5818 kg) (1). Each module is composed of two solar array assemblies (SAA), an integrated equipment assembly (IEA), two beta joints, and electrical and structural interface hardware. A detailed view of the SS PV power module is shown in Fig. 3. The IEA contains the nickel-hydrogen (NiH₂) battery energy storage assembly (the ESA), thermal control system (TCS) components, and PMAD system electrical components. Raw dc power is generated by two dual-blanket silicon cell solar arrays. The peak power capability of each module is 48 kWe (from 53 368 solar cells) at the beginning of life (BOL). Actual power output depends on solar array temperature, pointing accuracy, and duration in the LEO environment. A typical BOL power flow diagram for the PV module is shown in Fig. 4. While supplying 18.75 kWe of ac power, the PV module must simultaneously provide dc power to fully charge the ESA batteries by the end of the 60 min sunlit portion of each orbital revolution. Eclipse power is provided by the NiH₂ batteries in the ESA.

The PV module must also offset parasitic losses incurred in battery charging and in dc to ac inversion for distribution, and it must be capable of providing 30 kWe ac of peak power for up to 15 min per orbit if necessary with no limit to the number of consecutive peaking orbits (2). PV module design will incorporate the electrical equipment capability to deliver 139 kWe of SD-based average power and 156 kWe of SD-based peak power. This requirement is in anticipation of SS EPS growth to 300 kWe (350 kWe peak) (3).

During normal operations, ESA batteries are to be fully charged at the end of the sunlit portion of each orbit. They are sized to provide full ac power (18.75 kWe) during eclipse without exceeding a 35 percent depth of discharge (DOD). They must also be able to provide a minimum of 6.7 kWe of ac power per module for one complete orbit with no solar energy input. During this contingency operation, the energy storage batteries shall not exceed an 80 percent DOD. Each PV module must also supply reduced-level ac power during the initial SS construction process. This requires that the PV module function semi-autonomously after initial deployment in LEO until SS systems are functioning.

The thermal control system (TCS) design requirements are driven by the combined thermal load of the ESA and PMAD electrical components in the IEA. The NiH₂ batteries must be maintained at 5 °C (+15/-5 °C) under all operating conditions. The TCS is a mechanically pumped refrigerant system capable of removing 7 kWt of waste heat from the IEA.

The beta joint attaches the PV module SAA to the SS structure and also allows transfer of dc electrical power and communication signals to the ESA and PMAD system components. The beta joint allows the PV arrays to track the sun over seasonal orbit variations ($\pm 28.5^\circ$). It utilizes its own controller and motor drive, and is capable 360° rotation. Structural and interface hardware attach the beta joint and the IEA to the SS truss members. Electrical cabling and interconnect hardware allow electrical power flow and data communication between the PV module assemblies and PMAD components. PMAD electrical components housed in the IEA control power flow to meet SS load requirements.

Design lifetimes differs among the PV module components. The SAA is designed for 15 years, and the

beta joint for 20 years, of on-orbit operation. PMAD electrical equipment and all ESA hardware are designed for 5 year orbital lifetimes. Thermal control components are designed for 10 years of orbital operation.

Standard interfaces and a high degree of modularity are designed into all components to facilitate on-orbit service in LEO by robotic manipulators or by astronaut extra vehicular activity (EVA).

THE SOLAR ARRAY ASSEMBLY

Each solar array assembly (SAA) is composed of two blankets attached to a central deployment mast and canister and a sequential shunt unit (SSU) also attached to the mast canister. The SAA weighs roughly 1400 lb (632 kg). The SSU controls solar array output by shunting excess capacity when SS loads are less than the available solar array output power and the energy storage batteries are fully charged. It also prevents solar array output voltage from exceeding 200 V dc. The SSU has its own embedded processor but can also be controlled by the PMAD system.

Each solar array blanket weighs 490 lb (224 kg) and contains 76 active panel sections with 192 silicon solar cells on each panel for a total of 14 592 cells per blanket. (Platform and Co-orbiter PV blankets have fewer active panels.) Hinges between panels allow accordion-style folding of the arrays for compact stowage and pre-loading protection during launch. The silicon solar cells are 8x8 cm (3.15 by 3.15 in.) with truncated corners and gridded back-surface contacts. Cell efficiency is 14 percent at a predicted operating temperature of 20 °C at BOL (4). The 8 mil thick cells are protected by 6 mil thick ceria-doped glass covers held on by a transparent adhesive, as shown in Fig. 5. Cell mounting tape attaches the solar cells to an outer layer of Kapton¹ polyimide film. A thin, copper circuit, encapsulated between this outer Kapton layer and an inner layer, allows welded electrical connection to the back surface of the solar cells through pre-punched holes in the film. A polyester adhesive bonds the inner and outer Kapton layers.

The physical and electrical configuration of the individual solar panels is shown in Fig. 6. Each panel is 14.7 in. long (37.3 cm), 164 in. (416.6 cm) wide and hinged to adjacent panels to form the 95.5 ft (29.1 m) long solar array blanket. Two flat-conductor-cable (FCC) electrical harnesses are routed along the blanket edges to carry bulk dc power to the base of the array. The solar cells are electrically connected in a series string of 192 individual cells (an entire panel) with every 16 cells protected from shadowing or damage by redundant by-pass diodes. The strings (192 series connected cells) from two adjacent panels are wired in series to produce 160 V dc. Each panel pair is wired in reverse current direction, relative to adjacent panel pairs, to provide magnetic field cancellation. A solar cell base contact resistance of 2 Ω -cm was selected to minimize cell interaction with the LEO radiation environment (5). Table II summarizes the materials used to fabricate the SAA.

The LEO environment has a significant impact on the materials selected for construction of the solar arrays and their supporting structural elements. The

¹Kapton is a registered trademark of DuPont.

most important environmental concerns are atomic oxygen (AO) interaction, micrometeoroid and space debris impacts, and radiation and plasma interactions. The SS solar arrays are oversized by roughly 15 percent to account for anticipated damage during their 15 year design lifetime in LEO. This oversizing factor takes into account all LEO environmental factors mentioned above.

Atomic oxygen degrades organic polymer materials (like Kapton) by interaction with hydrogen-carbon and hydrogen-oxygen bonds (6). Atomic oxygen energies of 4 to 5 eV are encountered at the SS altitude. Protection for the solar array Kapton material will be provided by protective coatings which prevent AO interaction with the organic structure of the material. The mast and other structural components may be protected by adhesive aluminum tape or fine aluminum braiding.

Micrometeoroid and space debris impact damage is due to collision of small particles with solar array components. Micrometeoroids and space debris can be divided according to average particle density and kinetic energy. Space debris has an average density of 2.7 gm/cm^3 (0.098 lb/in.^3) and travels at orbital velocities (10 km/sec or 22 370 mph) in LEO. Micrometeoroid average density is much less, 0.5 gm/cm^3 (0.002 lb/in.^3), but these particles have velocities of up to 20 km/sec (44 740 mph) (7). Impact damage from space debris and micrometeoroids can be significant. The 6 mil glass covers on the solar cells protect the cell from micrometeoroid damage. The by-pass diodes ensure a continuous electrical collection path if individual solar cells are damaged by space debris impact.

Radiation damage to silicon solar cells results in a predictable performance degradation over time. Solar array oversizing is used to meet power demands at the end of life (EOL). Plasma interactions with the solar array include: current collection, arcing, and charging effects (polar orbit only). SS solar array maximum voltage is limited to 200 V to prevent arcing which could cause localized damage to the solar arrays (8). Normal array operating voltage is 160 V dc. LEO plasma interactions are strongest near the Earth's north and south poles where the magnetic field lines converge.

SAA MAST AND CANISTER

The solar array mast is a coilable, continuous-longeron design utilizing three S2-glass/epoxy longerons, connected by short battens of the same material, and diagonal tension wires, as shown in Fig. 7. The mast extends and retracts the two solar array blankets which are connected to protective blanket covers on either side of the mast. The mast is stored in a mast canister and is deployed or retracted by a rotating deployment mechanism. This mechanism has internal spiral grooves which guide mast roller lugs located on the mast longerons at each batten attachment point. The solar array blanket panels fold or unfold continuously as the mast is retracted or deployed. The mast is attached to a rotating baseplate in the bottom of the canister so that the extended mast does not rotate.

The solar array mast is the primary structural support for the solar arrays at any extended position. The solar arrays are maintained in a planar surface by tensioned guide cables and by the extended mast. Mast stiffness and blanket tension cables provide a first

mode bending frequency of a least 0.1 Hz. The mast canister is attached to a rotating beta joint which mechanically and electrically connects the SAA with the SS truss structure. The SAA mast and canister weigh 361 lb (164 kg).

THE IEA

The IEA provides the mounting structure and the thermal interface for the ESA, the TCS, and PMAD components. The PV ESA is comprised of NiH_2 cell batteries, and power charge and discharge control electronics. Ninety-two 65 A-hr cells packaged in four groups of 23 cells each, provide 380 A-hrs of total storage capacity. ESA total weight is ~3470 lb (1577 kg). The NiH_2 cells utilize a 31 percent by weight potassium hydroxide electrolytic solution and are housed in individual Inconel 718 pressure vessels. Cell operating pressure is 900 psi with a nominal 3:1 safety factor.

The IEA is thermally regulated by an active TCS serving the all active components. A two-phase ammonia (NH_3) refrigerant loop transfers waste heat from the ESA batteries and electrical equipment components to a condenser heat exchanger. Batteries and electrical equipment in the IEA are mounted on individual cold plates, which transfer waste heat via closed heat pipes, to separate TCS cold plates containing the circulating NH_3 . Mechanical pumps circulate the NH_3 between the TCS cold plates and the condenser heat exchanger. The heat exchanger transfers heat in the refrigerant to an aluminum heat pipe radiator for rejection into space. Each 18.75 kWe module has one 560 ft^2 (52 m^2) radiator positioned to minimize thermal interaction with other SS structures.

PV MODULE BETA JOINT

The beta joint is an actively-controlled, motor-driven bearing joint which allows seasonal tracking of the sun (orbital sun tracking is accomplished by the station's alpha joints). The joint also contains the electrical roll ring assembly which transmits bulk dc power from the solar arrays to the integrated equipment assembly (IEA) and also allows electrical communication between the array SSU and PMAD system components also located in the IEA. DC electrical power and data signal transfer is accomplished via roll rings in the joint. The beta joint weighs ~600 lb (273 kg).

CONCLUDING REMARKS

PV power modules offer low technical risk for SS electrical power production through demonstrated performance, high reliability, and on-orbit serviceability. They are a cost-effective and technologically mature approach to provide reliable SS electrical power in LEO and they provide a solid base for evolutionary SS power system growth. SS power demands are projected to grow to 300 kWe by the end of the SS 30 year design lifetime. The 18.75 kWe PV power modules are the cornerstone of SS deployment in LEO. Four of these modules will provide 75 kWe of PV-based ac power (out of 125 kWe total ac power) when the SS is fully deployed. Power requirements in excess of 75 kWe ac will be met by advanced solar-thermal power systems currently under development. The PV power

module design emphasizes high reliability hardware (and software), long life components, and a high degree of modularity and safety, to provide reliable SS electrical power and to accommodate EPS growth or reconfiguration in LEO as user needs evolve.

ACKNOWLEDGEMENTS

The author would like to thank the following Lewis colleagues who provide valuable data and insight for this paper; Mr. Cosmo Baraona, Mr. Michael Ciancone, and Mr. Henry K. Nahra.

REFERENCES

1. "Power System Description Document (PSDD)," Internal Document, Space Station Systems Directorate, NASA Lewis Research Center, Cleveland, OH, Sept. 11, 1987.
2. "Photovoltaic (PV) Power Module Systems, Part I, Contract End Item Specification," LeRC-SS-002, Internal Document, Space Station Systems Directorate, NASA Lewis Research Center, Cleveland, OH, Feb. 1987.
3. "Electrical Power System (EPS) Requirements Document," LeRC-SS-001, Internal Document, Space Station Systems Directorate, NASA Lewis Research Center, Cleveland, OH, Feb. 1987.

4. Elms, R.V., "Solar Arrays for Space Station and Platforms," Advancing Toward Technology Breakout in Energy Conversion (21st IECEC), Vol. 3, American Chemical Society, Washington, D.C., 1986, pp. 1898-1902.
5. "Space Station WP-04 Power System, Preliminary Analysis and Design Document DR-02," Vol. 1, RI/RD85-320-2, Rocketdyne Division, Rockwell International, Dec. 1986.
6. Nahra, H.K., Personal Communication, NASA Lewis Research Center, Cleveland, OH, Aug. 1987.
7. Cour-Palais, B.G., "Meteoroid Environment Model-1969, Near Earth to Lunar Surface," NASA SP-8013, 1969.
8. Snyder, D.B., and Tyree, E., "The Effect of Plasma on Solar Cell Arc Characteristics," AIAA Paper 85-0384, Jan. 1985. (NASA TM-86887).
9. Kempke, E.E., Jr., "Development of the Power System for the United States Manned Space Station," Energy for the Twenty-First Century (20th IECEC), Vol. 1, SAE, Warrendale, PA, 1985, pp. 1.139-1.144.

TABLE I. - SPACE STATION EPS DEVELOPMENT OPTIONS

[PV = photovoltaic; SD = solar dynamic.]

EPS option	Station EPS configuration	Platform EPS System
1 (phase 1)	75 kWe PV system (with SD preliminary design)	3.8 kWe PV for polar platform
1 (phase 2)	50 kWe SD additional (125 kWe EPS total)	3.0 kWe PV for co-orbiter
2	87.5 kWe hybrid system 37.5 kWe PV 50 kWe SD	3.8 kWe PV for polar platform and 3.0 kWe PV for co-orbiter

TABLE II. - SOLAR ARRAY ASSEMBLY MATERIALS

[TBD = to be determined.]

Component	Material	Size
Blanket		
Cell cover	Ceria-doped	6 mils nominal thickness
Cover adhesive	DC 93-500	2 mils maximum thickness
Solar cell	Silicon, 2 Ω -cm base resistance grided back, rear contact, solderless	8 x 8 cm (60.4 cm ² effective area) x 8 mils
Interconnect	Photo-etched copper	1.5 mils thick
Substrate	Protective coating Kapton Polyester adhesive Kapton Protective coating	TBD 1 mil 0.5 mils 1 mil TBD
Harness	Flat conductor cable (copper or Al)	3 mils
Hinge Pins	S2-glass/epoxy	TBD
Panel frame Stiffeners Sleeves	Graphite/epoxy Kapton	TBD TBD
Springs	Steel	TBD
Grommets	TBD	TBD
Guide wires	Steel	TBD
Blanket box		
Cover/base	Perforated Al honeycomb core Gr/Ep facesheets	164.1 x 14.7 in. 1 in Al 36 mils graphite/epoxy
Latches	Aluminum	TBD
Cable/guide wire reel	Magnesium	TBD
Negator spring reel	Delrin	TBD
Cables	Steel	TBD
Array deployment mechanism		
Mast		
Longerons	S2-glass/epoxy	0.39 in per side
Battens	S2-glass/epoxy	0.30 in per side
Diagonals	7 x 7 steel cable	0.10 in per side
Rollers	Vespel	TBD
Pivots	7075 aluminum	TBD
Canister	6061 aluminum	33.8 in max diam. x 61 in max length
Positioning mechanism	6061 aluminum	TBD

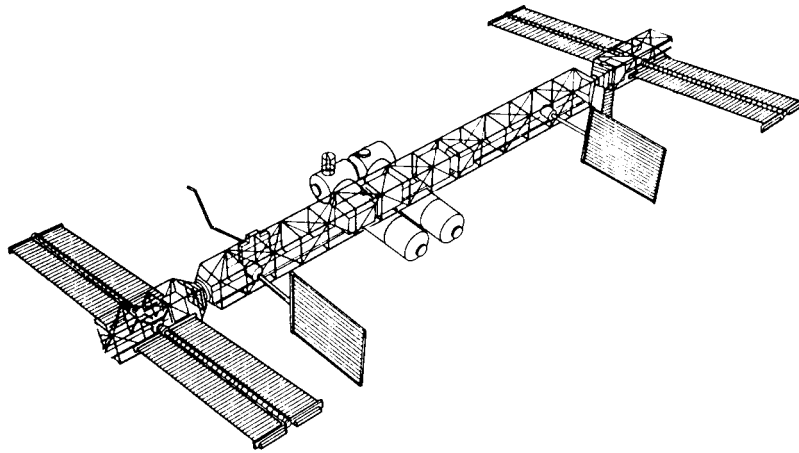

37.5 kWe PV EPS (INITIAL DEPLOYMENT)

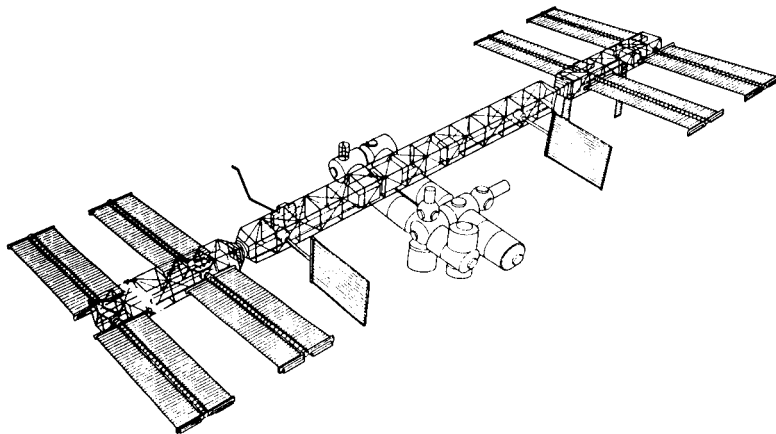

75 kWe EPS (INITIAL OPERATING CONFIGURATION) - PHASE I DEPLOYMENT COMPLETED
 FIGURE 1. - SPACE STATION EPS PHOTOVOLTAIC (PV) POWER MODULE DEPLOYMENT SEQUENCE.

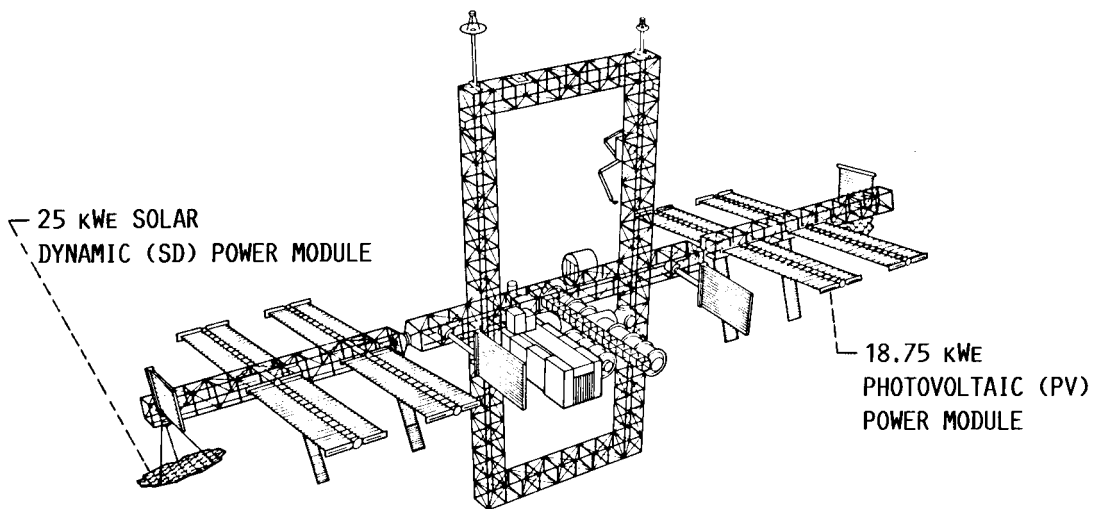
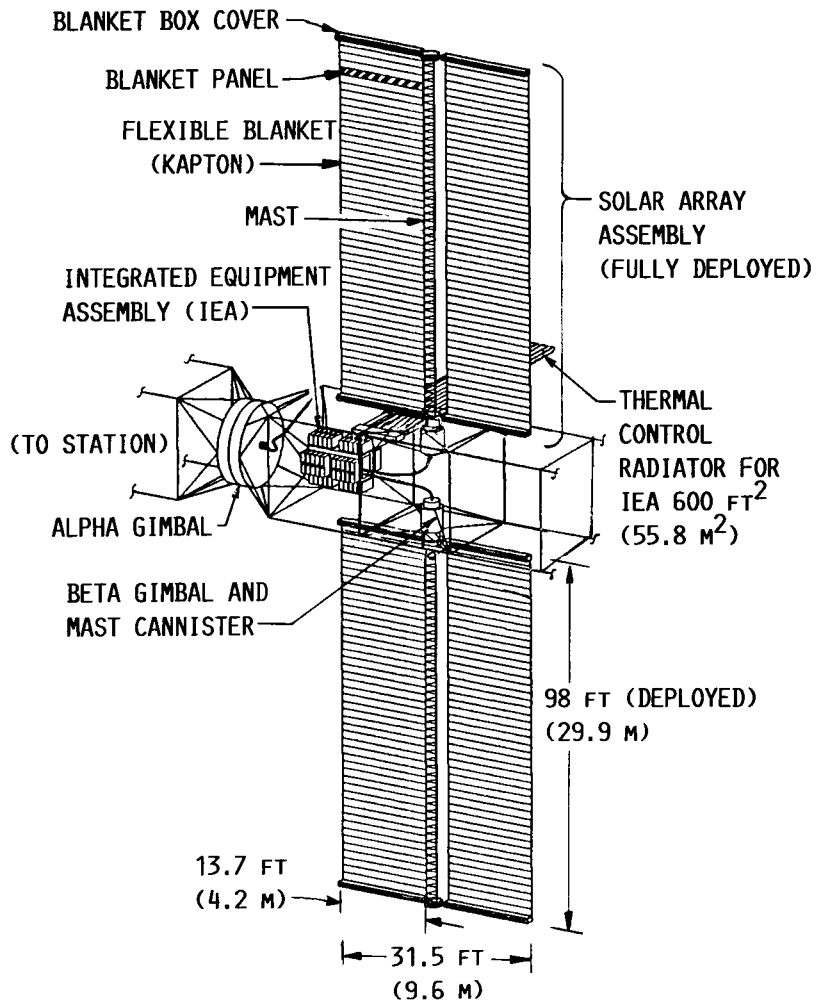

FIGURE 2. - SPACE STATION 125 kWe ELECTRIC POWER SYSTEM (EPS) UTILIZES PV AND SD POWER MODULES.



DIMENSIONS TAKEN FROM NASA LERC POWER SYSTEM
DESCRIPTION DOCUMENT (REF. 1)

FIGURE 3. - 18.75 kW_e STATION PV POWER MODULE.

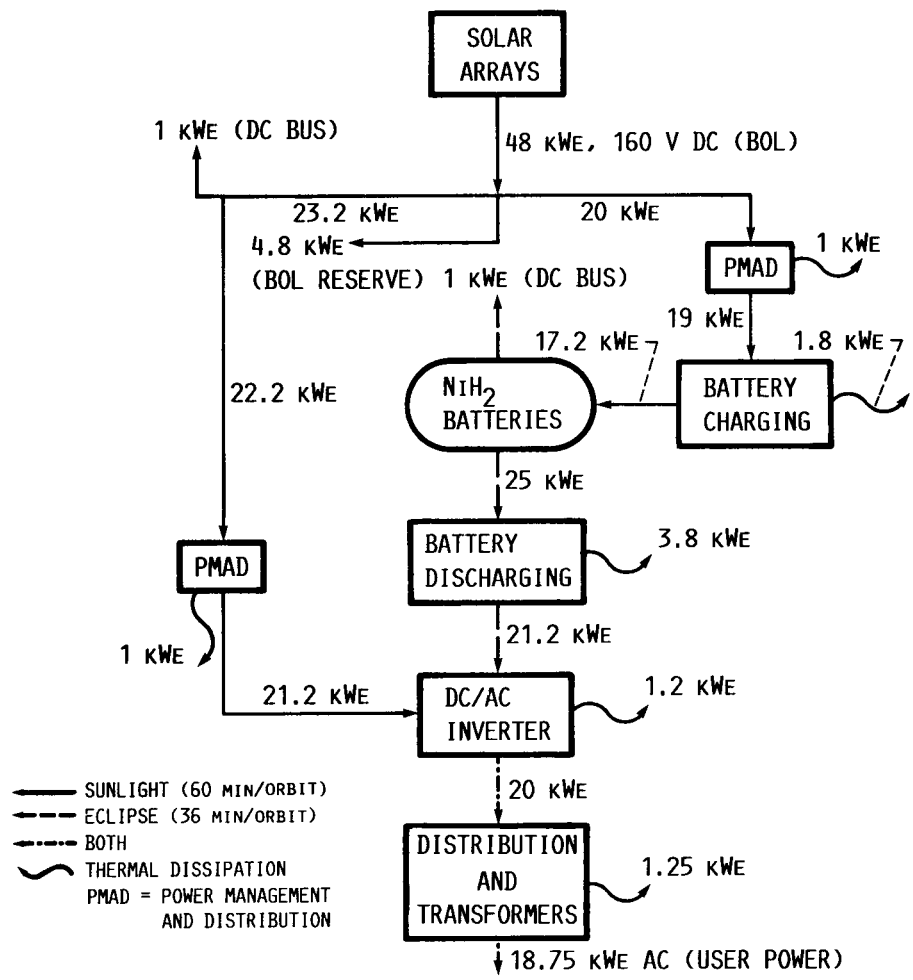

FIGURE 4. - SPACE STATION PV MODULE POWER FLOW DIAGRAM (TYPICAL).

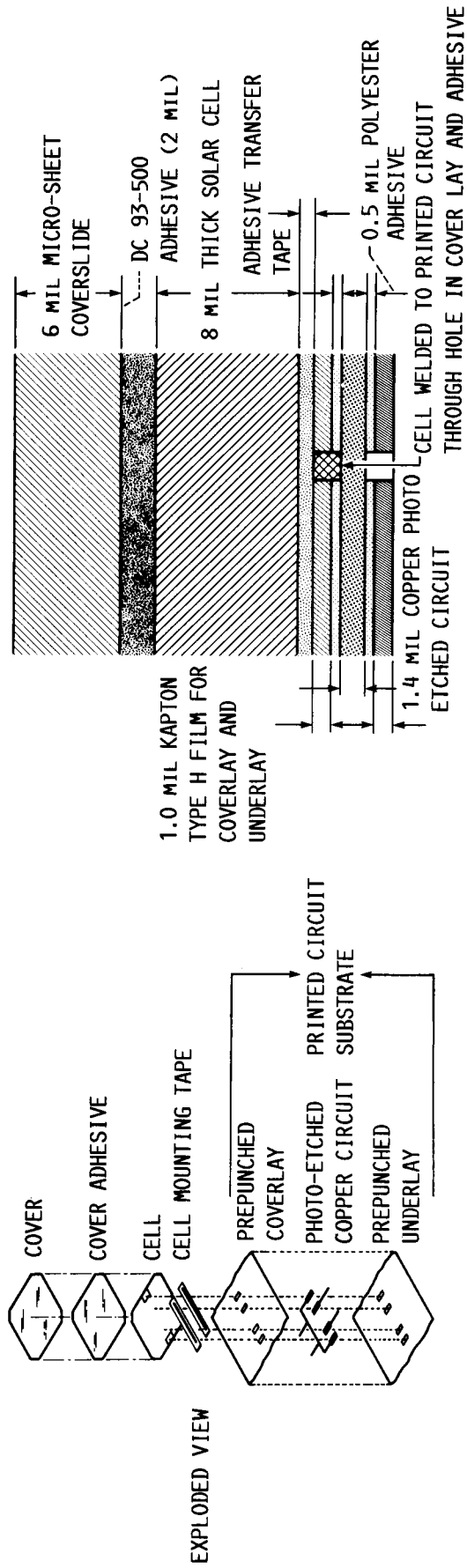

FIGURE 5. - SOLAR CELL ATTACHMENT TO BLANKET - EXPLODED VIEW AND TYPICAL CROSS-SECTION.

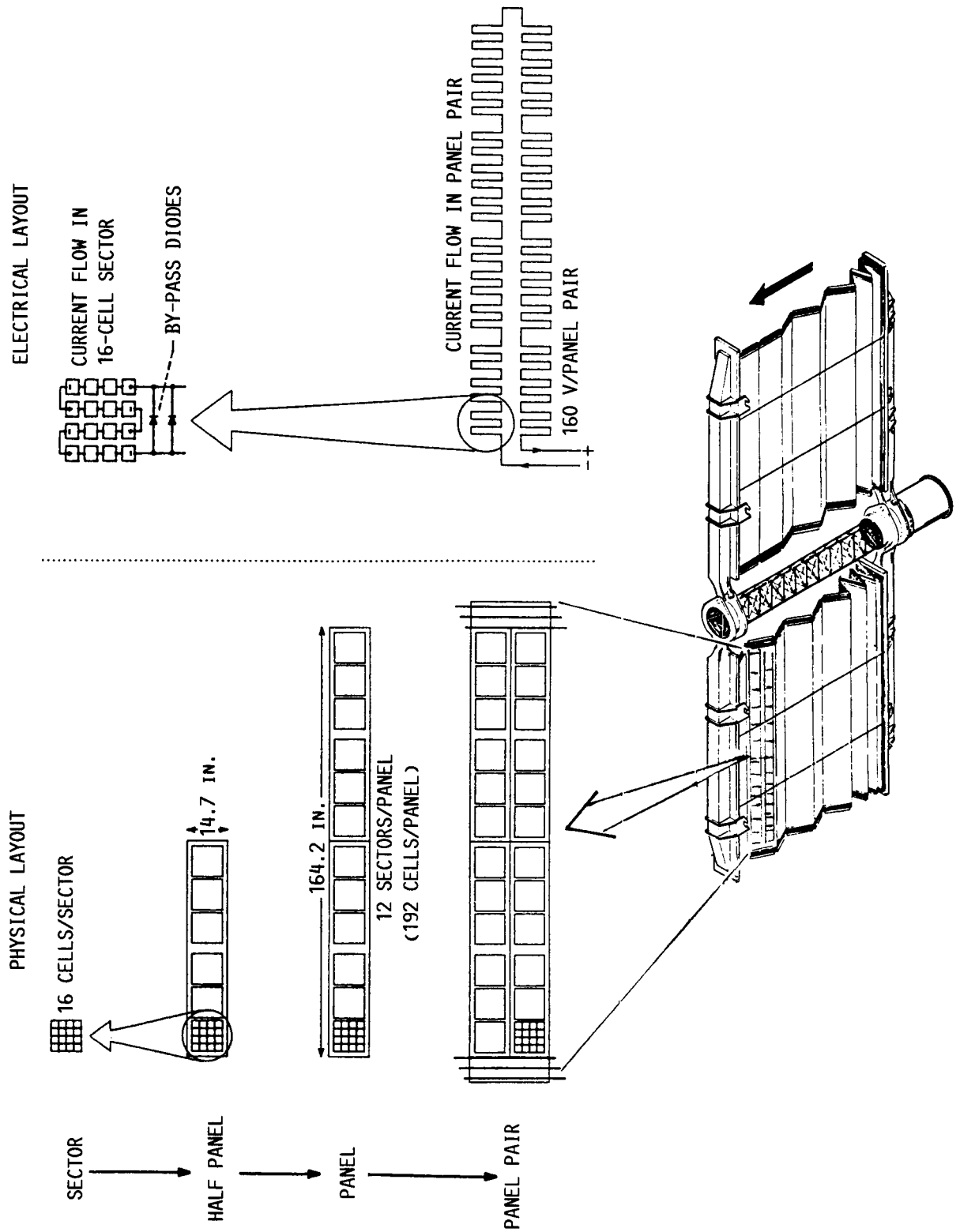

FIGURE 6. - SOLAR ARRAY BLANKET PHYSICAL AND ELECTRICAL CONFIGURATION.

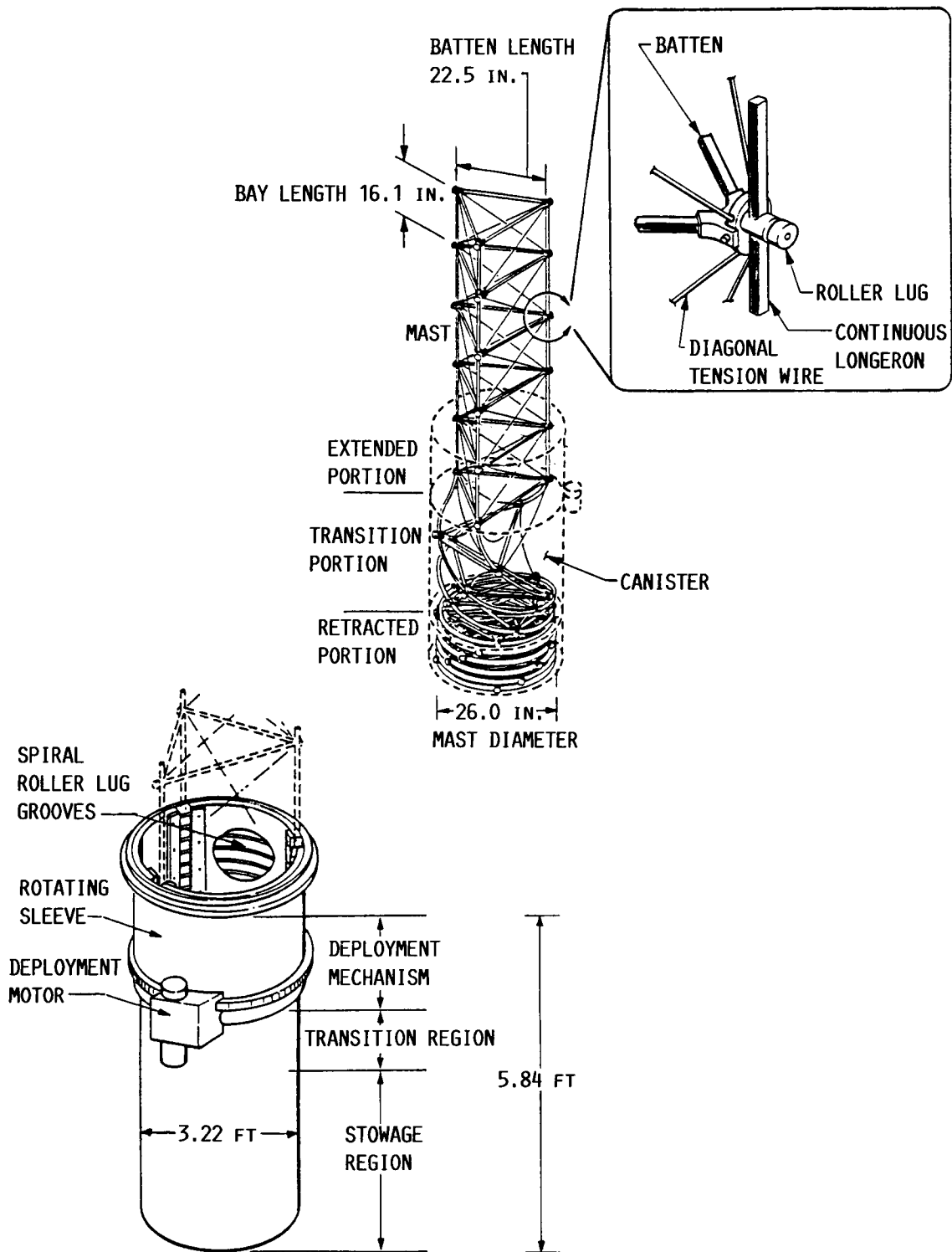

FIGURE 7. - SOLAR ARRAY MAST AND CANISTER.



National Aeronautics and
Space Administration

Report Documentation Page

1. Report No. NASA TM-100229		2. Government Accession No.		3. Recipient's Catalog No.	
4. Title and Subtitle Photovoltaic Power Modules for NASA's Manned Space Station				5. Report Date	
				6. Performing Organization Code	
7. Author(s) Charles A. Tatro				8. Performing Organization Report No. E-3850	
				10. Work Unit No. 482-55-52	
9. Performing Organization Name and Address National Aeronautics and Space Administration Lewis Research Center Cleveland, Ohio 44135-3191				11. Contract or Grant No.	
				13. Type of Report and Period Covered Technical Memorandum	
12. Sponsoring Agency Name and Address National Aeronautics and Space Administration Washington, D.C. 20546-0001				14. Sponsoring Agency Code	
15. Supplementary Notes Prepared for the 1988 Solar Energy Conference sponsored by the American Society of Mechanical Engineers, Golden, Colorado, April 10-14, 1988.					
16. Abstract The capability and the safety of manned spacecraft are largely dependent upon reliable electric power systems. Two similar space power systems able to survive the low-earth orbit environment, are being considered for NASA's Manned Space Station (SS), scheduled to begin operation in the mid 1990's. The Space Station Electric Power System (EPS) is composed of Photovoltaic (PV) Power Modules, Solar Solar Dynamic (SD) Power Modules, and the Power Management and Distribution (PMAD) System. One EPS configuration will deliver 37.5 kW of PV-based, utility-grade, ac power to SS users. A second 75 kWe PV-based EPS option is also being considered for SS deployment. The two EPS options utilize common modules and differ only in the total number of PV Power Modules used. Each PV Power Module supplies 18.75 kWe of ac power and incorporates its own energy storage and thermal control. The focus of this paper is on the general requirements and the current preliminary design configuration of the Space Station PV Power Modules.					
17. Key Words (Suggested by Author(s)) Space station Photovoltaic power systems Space solar power			18. Distribution Statement Unclassified - Unlimited 20 Subject Category		
19. Security Classif. (of this report) Unclassified		20. Security Classif. (of this page) Unclassified		21. No of pages 12	22. Price* A02