

DOE/NASA/1005-12
NASA TM-88886

Overview of Free-Piston Stirling Engine Technology for Space Power Application

(NASA-TM-88886) OVERVIEW OF FREE-PISTON
STIRLING ENGINE TECHNOLOGY FOR SPACE POWER
APPLICATION Final Report (NASA) 23 p
Avail: NTIS HC A03/MF A01 CSCL 10B

N88-12427

G3/85 Enclas
0108421

Jack G. Slaby
National Aeronautics and Space Administration
Lewis Research Center

1988-12427
N88-12427
N88-12427
N88-12427
N88-12427
N88-12427
N88-12427
N88-12427

Work performed for
U.S. DEPARTMENT OF ENERGY
Conservation and Renewable Energy
Division of Building and Community Systems

Prepared for
Solar Energy Conference
cosponsored by ASME, JSME, and JSES
Honolulu, Hawaii, March 22-27, 1987

Overview of Free-Piston Stirling Engine Technology for Space Power Application

Jack G. Slaby
National Aeronautics and Space Administration
Lewis Research Center
Cleveland, Ohio 44135

Work performed for
U.S. DEPARTMENT OF ENERGY
Conservation and Renewable Energy
Division of Building and Community Systems
Washington, D.C. 20545
Under Interagency Agreement DE-AI05-82OR1005

Prepared for
Solare Energy Conference
cosponsored by ASME, JSME, and JSES
Honolulu, Hawaii, March 22-27, 1987

Overview of Free-Piston Stirling Engine Technology For Space Power Application

by

Jack G. Slaby

National Aeronautics and Space Administration
Lewis Research Center
Cleveland, Ohio 44135

ABSTRACT

An overview is presented of the National Aeronautics and Space Administration (NASA) Lewis Research Center (LeRC) free-piston Stirling engine activities directed toward space-power application. Free-piston Stirling technology is applicable for both solar and nuclear powered systems. As such, the NASA Lewis Research Center serves as the project office to manage the newly initiated SP-100 Advanced Technology program. This program provides the technology push for providing significant component and subsystem options for increased efficiency, reliability and survivability, and power output growth at reduced specific mass.

One of the major elements of the program is the development of advanced power conversion of which the Stirling cycle is a viable candidate. Under this program the status of the 25 kWe opposed-piston Space Power Demonstrator Engine (SPDE) is presented. Included in the SPDE discussion are initial differences between predicted and experimental power outputs and power output influenced by variations in regenerators.

Technology work is also conducted on heat-exchanger concepts, both design and fabrication, to minimize the number of joints as well as to enhance the heat transfer in the heater. Design parameters and conceptual design features are also presented for a 25 kWe, single-cylinder free-piston Stirling space-power converter. Projections are made for future space-power requirements over the next few decades along with a recommendation to consider the use of dynamic power-conversion systems—either solar or nuclear. A cursory comparison is presented showing the mass benefits that a Stirling system has over a Brayton system for the same peak temperature and output power.

A description of a study to investigate the feasibility of scaling a single-cylinder free-piston Stirling space-power module to the 150 kWe power range is presented. The work discussed in this paper is synergistic with the NASA Advanced Solar Dynamic Program where NASA Lewis is conducting research on advanced concentrator, receiver and thermal energy storage systems at temperatures around 1000 K for Stirling and Brayton cycle power conversion systems.

INTRODUCTION

Free-piston Stirling technology was started with the work of William Beale at Ohio University around 1962. This early work resulted in small-scale fractional-horsepower engines which demonstrated basic engine operating principles. The potential advantages (hermetically sealed, high efficiency, and simplicity) of this type of engine became more widely recognized in the early 1970's. This recognition resulted in larger companies taking an interest in its development for heat pumps and solar applications.

Shortly thereafter, the Department of Energy (DOE) took an interest in heat pump development. One area of specific interest to the DOE is the free-piston Stirling engine-driven heat pump. Coincidentally, NASA Lewis was conducting research on free-piston Stirling engines as one of several candidates for potential space-power systems. Although both applications, residential heat pumps and space power, appear quite different, their requirements complement each other. These requirements include high efficiency, the potential for long life and high reliability, low vibration, and hermetic sealing. These common requirements became the basis for a cooperative interagency agreement (IAA) between DOE/Oak Ridge National Laboratory (ORNL) and NASA Lewis signed September 1982. The research resulting from this IAA covers generic free-piston Stirling technology applicable to both space power and terrestrial heat pump application. This generic technology effort will not be addressed further as part of this paper due to a length restriction. Reference 1 covers some of the generic work. However, this work is very important to better understand the fundamentals of free-piston Stirling technology.

In addition to the DOE/ORNL - NASA Lewis projects, an interagency agreement has been signed between DOE/Sandia National Laboratory and NASA/Lewis to utilize Stirling space technology for solar thermal terrestrial application for generating solar derived electrical power.

And finally, the SP-100 Space Reactor Power Program was established by NASA, the Defense Advanced Research Projects Agency, Department of Energy (DOE) and the Air Force in February 1983. For almost 3 years various

E-3295

power conversion concepts were investigated, until recently, when the thermoelectric concept was chosen for development and ground testing to be conducted until 1991. This SP-100 program is now in the first year of a 5-year phase II Ground Engineering System (GES) program. In support of this program, free-piston Stirling system technology development is continuing under the newly initiated SP-100 Advanced Technology Program. The NASA Lewis Research Center serves as the project office for NASA's SP-100 Advanced Technology Program, the purpose of which is to demonstrate the technology necessary to proceed into final development of a space-qualified free-piston Stirling engine to meet future mission needs. The free-piston Stirling advanced technology work described in this report is either conducted at or managed by the NASA Lewis Research Center in support of the NASA SP-100 Advanced Technology Program.

WHY FREE PISTON?

The Stirling free-piston system has many attractive attributes, several of which are tabulated in Fig. 1. Specifically, the Stirling cycle is the most efficient thermodynamic heat engine cycle that exists. Of the concepts considered for SP-100 selection, the Stirling cycle has the highest efficiency for the same given heat input and heat rejection temperatures. Because the Stirling system employs the gas bearing - either hydrodynamic or hydrostatic - there is the potential for long life and high reliability.

A system composed of a Stirling engine/linear alternator has only two moving parts per cylinder - that is the displacer and the power piston/alternator plunger. The result is a relatively simple configuration. A single-cylinder engine can be balanced either actively or passively using a spring-mass combination.

Free-piston Stirling engines contain no sliding rod seals such as those present in the kinematic concepts. The energy conserved by not having to overcome the losses in the frictional rod seals is not totally free. The free-piston Stirling concept utilizes gas springs which have hysteresis losses. At the present time, it is not known whether the free-piston concept or the kinematic concept is the most efficient, but it is felt that there should not be much difference between the efficiencies of the two concepts. The fact that there is no oil inside the engine makes the free-piston a strong candidate for long life. There is no chance of getting oil contamination into the regenerator and degrading engine performance. An opposed-piston free-piston Stirling engine with a common expansion space, theoretically has the potential for graceful degradation in the event that one engine has larger losses than the other. Both pistons then produce equal power, but at a reduced level.

The power output of the free-piston is very flexible in that not only is a linear alternator possible, but so are other concepts. These concepts include the hydraulic output with a hydraulic motor/pump and a conventional rotating alternator; and a hydraulic drive/gas compressor output which can provide gas turbine power to a conventional or high speed alternator.

STIRLING/BRAYTON SYSTEM MASS COMPARISONS

Reference 2 has assembled information from various NASA Lewis conducted dynamic space power systems analyses. The purpose of the Ref. 2 study was to compare the different nuclear and solar dynamic power system technologies on the basis of system mass and drag area with emphasis on the growth space station application. The comparisons presented here, based on these references, show only the mass variation, and are considered

preliminary, in that results can be expected to change as assumptions and analyses are refined and as different tradeoffs are examined. However, it is believed that the relative comparisons are basically valid. It is clear that other system characteristics such as cost, reliability, development status and safety will greatly impact additional comparisons. For the purpose of the study a 40 kWe solar dynamic system module size was assumed, with four modules producing 160 kWe. Each module is a self-contained power system consisting of a solar collector, heat receiver, power conversion system (including engine and energy storage), power system radiator, and power conditioning system.

The nuclear dynamic system consists of a single liquid-metal cooled reactor, a man-rated radiation shield, multiple Brayton or Stirling engines (for redundancy), power system radiators, and power conditioning.

The operating parameters for the solar dynamic system are shown in Fig. 2. These parameters are shown for both solar Brayton and solar Stirling systems. For the Brayton system, the turbine inlet temperature is 1083 K, while for the Stirling engine, the engine inlet temperature is 1089 K. For the Brayton system, the compressor inlet temperature, compressor pressure ratio, and recuperator effectiveness were selected to yield a minimum system mass. The cycle temperature ratio for the Stirling engine was selected as a compromise between system mass, collector size, and required radiator heat transfer area. A Stirling engine efficiency of 64 percent of Carnot, which also includes the alternator efficiency, was assumed. This represents a near-term state-of-the-art design for free-piston Stirling space power systems. The engine specific mass used was for a 40 kWe Stirling power module.

In the solar study considered, the heat storage media is either LiF or LiOH. Keep in mind that the closed Brayton cycle engine is more developed than the free-piston Stirling, but the free-piston Stirling offers the potential for higher conversion efficiency with lower required collector and radiator area.

The nuclear dynamic system parameters are also shown in Fig. 2. The nuclear reactor models used in this analysis were for a liquid metal cooled reactor with the coolant exiting the reactor at 1100 K. The mass and size of the reactor are based on models supplied by the Los Alamos National Laboratory (LANL). For the Brayton system the compressor inlet temperature and pressure ratio were selected as a trade-off between minimum system mass and radiator heat transfer area. The recuperator effectiveness assumed was based on a separate analysis. The basis for the Stirling system parameters are studies conducted by system contractors during the Phase I portion of the SP-100 concept selection. The nuclear power system consists of the nuclear reactor enveloped by a shaped 4 π , man-rated radiation shield. The nuclear power system is separated a distance from the space station habitat by a boom or tether, with electricity being transmitted down the boom or tether via a power cable. The nuclear reactor is assumed to be 30 m from the space station habitat.

Figure 3 gives a comparison of system weight between a nuclear Brayton and a nuclear Stirling system at 150 kWe. Clearly the man-rated shield dominates both systems. The nuclear Stirling system is about 13 percent lighter than the nuclear Brayton system. This mass advantage is primarily due to its higher conversion efficiency resulting in lower shield mass and in a substantially smaller radiator resulting from Stirling's higher efficiency and higher heat rejection temperature. The difference in power level between the 150 kWe nuclear and the 160 kWe solar is the result of using available data. The 160 kWe solar is composed of 4 to

40 kWe modules. Whereas the nuclear system was an existing 150 kWe system.

Figure 4 compares the solar dynamic systems. Here the Stirling system is at least 25 percent lighter than the Brayton system. The mass results shown are based upon Stirling engine mass and efficiency assumptions used for SP-100 phase I calculations and includes mass estimates for the solar receiver and collector which were scaled from the Brayton system analysis. Thus, the absolute values should be considered tentative, pending more detailed analysis and modelling using a solar heat source. The relative Stirling advantage over the Brayton system is not expected to change.

Figure 5 shows total system mass for both Brayton and Stirling systems each using solar and nuclear energy sources. The solar power systems are assumed to scale linearly with power, while the nuclear power systems scale less than linearly.

In all cases the Stirling system, because of its high efficiency, is the lighter system.

FUTURE SPACE POWER PROJECTIONS

Over the next several decades, the amount of electric power required in space is expected to grow immensely. Today's larger satellites require almost 10 kWe of power. Most of these satellites are powered by solar arrays with storage batteries. Tomorrow's space platforms will continuously require hundreds of kilowatts; and some will periodically consume many megawatt-hours of energy. These space platforms will include manned space stations, communication stations, surveillance platforms, and defense weapons. These large power systems will be quite different from today's solar arrays.

Projections of space power growth tend to show broad trends as shown in Fig. 6. These broad trends are a direct result of uncertainties in future mission capabilities and needs. It is however, clear that future space power needs may be several orders of magnitude greater than anything that has been accomplished to date. The challenge for the space power planner is formidable - to select power technologies that can meet the projected trends and adapt to multiple users. One potential solution is the use of dynamic power conversion units - either solar or nuclear.

Figure 7 is an artist's conception of an SP-100 Stirling engine system. The concept uses a nuclear reactor and shield along with both fixed and deployed radiator panels. Thermoelectric electromagnetic pumps are employed to transport the hot liquid from the reactor to the Stirling engines.

SCALING STUDY

The free-piston Stirling engine is an emerging candidate for space-power missions using either nuclear or solar heat sources. Recent work has keyed on FPSE designs, hardware fabrication, and testing below the 25 kWe power range. However, as discussed in the section Future Space Power Projections it is readily apparent that single-cylinder engines with power outputs above 100 kWe per cylinder are very desirable. Therefore, it is important to determine whether it is feasible to design a single-cylinder FPSE/LA system in the 100 to 150 kWe range.

As a consequence, NASA Lewis is in the process of awarding a small competitive contractual effort to investigate whether single-cylinder FPSE/LA systems can be designed in the 100 to 150 kWe power range. As part of this study recommendations will also be made for configurations other than linear alternators. Are there other configurations that may offer advantages over the

linear alternator configuration? Figure 8 outlines the scope of the work being considered under this study. The study will cover the power range from 25 through 150 kWe per cylinder. An option to the study is to determine the maximum power per cylinder if indeed it becomes apparent that power levels greater than 150 kWe per cylinder are feasible. The study will key on engine temperature ratios in the range of 1.7 to 3. It is in this range that the contractor will be asked to establish parametric relationships between percent Carnot cycle efficiency and specific mass, output power, and temperature ratio of the power conversion unit (i.e., Stirling engine plus linear alternator). This initial study will key on a temperature level of about 1050 K so that superalloys can be used. The design life shall be about 60 000 hr with helium as the working fluid and a specific mass target range of 5 to 8 kg/kWe.

SPACE POWER DEMONSTRATOR ENGINE (SPDE)

NASA Lewis, in coordination with the overall SP-100 development program, initiated an SP-100 Advanced Technology Program. The objectives of the Advanced Technology program are to augment the ground engineering system (GES) engineering development and ground testing of major subsystems and to provide significant component and subsystem options for increased efficiency, reliability, survivability, and growth, at reduced weight and high reliability. Thus, enhancing the chances of success for the overall SP-100 power system development.

These goals will be obtained through the key elements of the broadly based program which include: systems analysis to guide the overall effort and advanced technology development in the areas of Energy Conversion, Thermal Management, Power Conditioning and Control, Space Power Materials and Structures, and Spacecraft Environmental Effects. Building upon the technology advancements accomplished in Phase I of the SP-100 program, the advanced Stirling technology conversion project is one important element of the program. The key Stirling technology areas needed for this broadly based program are listed in Fig. 9.

In concert with the Advanced Technology Program a demonstrator engine was built and is currently under test. The engine is called the Space Power Demonstrator Engine (SPDE). The SPDE was designed and fabricated by Mechanical Technology, Inc. (MTI) of Latham, NY. The engine is currently under test at this facility. The nominal design was 25 kWe from the two opposed-piston Stirling engine - linear alternator system. A photograph of the engine is shown in Fig. 10. The engine is about 1-1/4 m in length and about 1/3 m in diameter. It is suspended from the ceiling by four vertical straps. This flexible suspension was the test configuration and no discernible vibration was observed during operation. Accelerometers mounted on the engine housing indicated maximum amplitudes (peak-to-peak) of less than 0.01 mm which corresponds to a "g" of less than 0.2. A general description of the engine is given in Refs. 3 and 4. Figure 11 is a cross section of half of the engine taken through a line of symmetry. The module shown was designed to produce 12.5 kWe - half the full engine power.

Because of the tight schedule to design, fabricate, and test the engine, the maximum engine temperature for initial testing was limited to 650 K. The cost of a liquid metal facility (necessary for higher temperature operation) was also a factor in selecting 650 K as the heater temperature. The cold or cooler temperature was maintained at 325 K in order to operate the engine at a temperature ratio of 2. The temperature ratio of 2 was chosen for a minimum weight system (including reactor and radiator).

The SPDE is a development engine and, as such, is not a final space configuration. However with straightforward material substitutions and replacing bolts and flanges with welds, the SPDE specific mass at design power is reduced to 7.2 kg/kWe from the laboratory specific mass of 12.7 kg/kWe.

The top curve of Fig. 12 shows predicted piston PV power at the design pressure - 150 bar - and design temperature ratio of 2.0. The piston PV power is presented instead of alternator output power because the alternator is currently not performing as expected. A detailed investigation is planned in regard to improving alternator performance. The bottom curve of Fig. 12 shows the PV power obtained with a regenerator that became damaged during the first 20 hr of 105 Hz operation. The power was about half the predicted power for a given piston amplitude (piston stroke is twice the piston amplitude); yet the engine ran well. This power shortfall was unexpected because at the half design pressure of 75 bar the experimental power was about 90 percent of the predicted power (6.0 kW experimental, 6.7 kW predicted with an alternator efficiency of about 93 percent). Keep in mind that the engine frequency also changes with engine pressure. At 75 bar the engine frequency is 74 Hz and at 150 bar the frequency is 105 Hz. A concentrated effort was conducted by both MTI and NASA to resolve the power shortfall problem. On balance, the mechanical operation of the engine has been flawless. Both power pistons (alternator plungers) and one displacer have been completely trouble-free. One displacer drive was troublesome until a positive cylinder alignment was incorporated into the design. In order to understand why there was a power shortfall additional instrumentation was added to the engine as well as a complete recalibration of all flow meters, resistance temperature devices, and pressure sensing devices. Thermocouples were located at the interface of each heat exchanger (i.e., heater - regenerator, regenerator-cooler, etc.).

A series of diagnostic tests were conducted in order to isolate potential power shortfalls. The tests consisted of cold and at temperature motoring tests with the displacer (one of the two moving parts per engine) locked in place. A motor-generator set supplied power to motor the alternator of the SPDE. The purpose of these tests was to determine whether gas leakage and/or hysteresis are a cause of the power shortfall. Additional motoring tests were conducted with both displacer and piston unlocked at a temperature ratio of 1. This test verified that leakage and/or hysteresis were not contributing to the power shortfall. The SPDE engine is at the forefront of Stirling technology and operates at 105 Hz, 1.75 times greater than previously designed Stirling engines (the equivalent to an automobile engine at 6300 rpm). As such, the higher frequency generates large dynamic oscillating forces on the regenerator which have resulted in regenerator fretting and damage. Previous free-piston Stirling regenerators - due to low frequency operation and to the low pressure ratio of free-piston engines - were not sintered or canned and maintained their integrity over long periods of operation.

As an example, the nominal 3 kW MTI Endurance Engine ran over 5500 hr without any regenerator problems. Nevertheless, Fig. 13 shows a comparison between the uncanned, unsintered screen regenerators before testing and after only about 20 hr of 105 Hz operation. Sintered and canned regenerators are on order for future testing.

The damaged screen regenerators were replaced with a sintered - though not optimized - regenerator of a smaller diameter wire and higher porosity. A photo of the replacement regenerator is shown in Fig. 14.

Although the regenerator was not optimum the performance improvement was dramatic. This can be seen by the middle curve in Fig. 12. The engine delivered 20.5 kW of power to the linear alternators at only 85 to 90 percent of full piston/alternator plunger stroke. Engine operation at this power level was made possible by the modification of an element of the load circuit which had previously prevented achievement of power levels greater than 14 kW. This modification was in addition to the regenerator replacement. Full design stroke of the piston/alternator plunger could not be reached at this time because of a progressive loss of gas bearing pressure with increase in alternator power. The loss of bearing pressure appears to be caused by a widening of the clearance gap between the piston and its cylinder. It is believed that heat rejected by the alternator causes expansion of the cylinder relative to the piston. Alternator efficiency at this power level is approximately 70 percent - considerably lower than the alternator design efficiency of 93 percent that was measured at lower power levels. The specific source of alternator power loss is currently being identified by work being done both by the Contractor (MTI) and by NASA Lewis personnel. The final testing is far from complete and early indications are that further power improvement is expected when the sintered screen regenerators are installed.

25 kWe SINGLE CYLINDER CONCEPT

Under SP-100 funding, Sunpower, Inc., of Athens, Ohio generated parametric relationships for free-piston Stirling engine linear alternator (FPSE/LA) systems such that for specified heater-to-cooler temperature ratios, equations were established to represent the interdependency between the FPSE/LA specific mass and percent of Carnot cycle efficiency. Sunpower then used these relationships to generate a conceptual design for a 25 kWe single-cylinder space power module incorporating refractory metal heat exchanger modules. The refractory heater module engine design parameters are listed in Fig. 15. It is of interest to note that the heater material was chosen as a refractory metal alloy niobium and zirconium (Nb-1Zr). The lifetime requirement was 70,000 hr and the heater temperature was 1080 K. Not listed under design parameters is the fact that hydrodynamic gas bearings were used on both reciprocating components, the displacer and the power piston (linear alternator plunger). The basic power module is a simple single-piston displacer design using an adaptive dynamic balance unit to minimize forces transmitted to the support structure. The dynamic balance unit, the heat-pipe heat exchanger assemblies, and the use of hydrodynamic gas bearings represent the only departure from conventional FPSE technology. A cross section of this concept is shown in Fig. 16 with a superalloy hot end. This design incorporates approximately 40 heat exchanger assemblies, one of which is schematically shown in Fig. 17 (assembled and unassembled). The module consists of a heater, regenerator, and cooler encased in a single tubular structure. This design contrasts with the conventional multitube (1600 tube heater and 1900 tube cooler) heat exchangers used in the SPDE. It significantly reduces the number of fabrication joints and also provides a better match of heat transfer between the liquid-metal side and the helium working fluid side. Sunpower and MTI are using used this single-cylinder concept as the basis for a preliminary design. This preliminary design will have a superalloy hot end. This work is currently underway. The preliminary design will be modified into an experimental version; and will

be designed for research instrumentation, ease of component modification, and ease of assembly and disassembly. By using super alloys for the heat exchangers it is easier, less expensive and faster to test and evaluate than a refractory metal engine. This engine, when built, will be tested at NASA Lewis in Cleveland, Ohio. The design conditions are listed in Fig. 15. In any event, heat pipes will be used to supply heat to the engine. At present interest is focused on the use of heat pipes inserted into modified heater modules as shown schematically in Fig. 18. A major advantage of this concept is the fact that the liquid metal is contained within the heat pipe and is not in contact with highly stressed engine components. Another feature of this design is the portion of the heat pipe in contact with the reactor working fluid can be clad with the same material that the reactor loop is fabricated from. Thus the potential for loop contamination by engine materials is avoided. The forty heat pipes are arranged in two concentric rings symmetrical around the displacer. This is shown in Fig. 19.

Figure 20 shows the impact on power and percent of Carnot cycle efficiency as the cold end (cooler) temperature is varied for a constant hot temperature of 1080 K. If the design point cooler temperature is lowered from 540 to 360 K the output power increases from 25 to 44 kw and the percent Carnot cycle efficiency increases from 59 to 65 percent. Keep in mind that the engine is optimized at a temperature ratio of 2. If the engine were reoptimized at a temperature ratio of 3 (360 K cooler temperature) the power and efficiency improvement would be even better. For this reason it is highly desirable to operate the Stirling engine at the highest possible temperature ratio. However, when systems are optimized for minimum systems weight, nuclear Stirling systems tend to optimize around temperature ratios of 2.0; and solar Stirling systems optimize around temperature ratios of around 2.5. These numbers vary slightly with varying missions. Even though this engine will not be tested for at least a couple of years, some of the heat exchanger assemblies as previously shown in Fig. 17 will be fabricated and tested separately. Three heat exchanger assemblies will be fabricated of materials proposed for this superalloy Stirling Space Engine. The assemblies will be flow-tested under both steady state and oscillating flow to verify design parameters. The flow rig is being built by Sunpower under a small business innovative research (SBIR) contract.

The 25 kWe super alloy Stirling space engine design incorporates many technology advances over the SPDE design. Fig. 21 lists some of these advances. Even though the temperature ratio of 2 is used for each design, the maximum temperature for the SSE design is raised more than 400 to 1080 K. This design is optimized for minimum specific mass (30 percent reduction over SPDE) and uses a heat pipe heater. Incorporated in the heat pipe heater design is a factor of 40 reduction in number of heater tubes. SPDE has 1600 tubes in the heater whereas the SSE design uses 40 heat exchanger modules - adding greatly to the simplicity and reliability of operation. The SSE design uses self energized hydrodynamic spin lubricated gas bearings whereas SPDE uses externally pumped hydrostatic gas bearings. A

separate radiator will be used to cool the magnets in the SSE thereby providing flexibility in choosing the cooler temperatures - which is important in determining the system radiator mass. The SSE design also uses liquid metal - probably sodium in the heat pipe design - which ensures a uniform heater temperature. And finally the power per cylinder is increased by a factor of 2 over the SPDE design to 25 kW per cylinder. This single cylinder SSE engine employs an active dynamic balance to reduce vibration to acceptable values - less than 3 mils engine casing amplitude.

CONCLUDING REMARKS

The space power demonstrator engine (SPDE) has successfully operated for over 300 hr and has delivered 20 kW of PV power to the alternator plunger. The SPDE has demonstrated that a dynamic power conversion system can be, with proper design, balanced; and the engine performed well with externally pumped hydrostatic gas bearings. Testing of the engine will continue its steady development and will provide a test bed to evaluate new and unproven components/technologies.

A 25 kWe single-cylinder Stirling space engine design is underway incorporating many advanced design features required for a prototypic flight engine. This engine uses super alloy materials and wherever possible uses concepts and components applicable for refractory metal (1350 K) application. This design features modular heat exchangers with sodium heat pipes, thereby, dramatically reducing the number of joints and enhancing the heat transfer capability.

In conclusion, we feel that the free-piston Stirling engines are just starting to achieve the attention and credibility that they deserve for space-power application. Free-piston Stirling systems can easily be used with both solar and nuclear powered systems and offer the potential for high efficiency, long life and high reliability.

REFERENCES

1. Slaby, J.G., "Overview of Free-piston Stirling Technology at the NASA Lewis Research Center," NASA TM-87156, 1985.
2. Nainiger, J.J. and McKissock D.B., "Mass, Area, and Propellant Requirement Comparisons of Several Potential Growth Space Station Power Systems," Preliminary Information Report No. 71, Space Station System Directorate, NASA Lewis Research Center, Cleveland, OH, Oct. 1984.
3. Dochat G.R., "Free-Piston Stirling Engines for Space Power," Proceedings of the Twenty-Second Automotive Technology Development Contractor's Coordination Meeting, Society of Automotive Engineers, Warrendale, PA, 1984 pp. 209-213.
4. Slaby, J.G., "Overview of Free-Piston Stirling SP-100 Activities at the NASA Lewis Research Center," NASA TM-87224, 1986.

- HIGH EFFICIENCY (RELATIVE TO OTHER SYSTEMS)
- POTENTIAL FOR LONG LIFE AND HIGH RELIABILITY
- NON-CONTACTING GAS BEARINGS
- TWO MOVING PARTS
- DYNAMICALLY BALANCED
- NO ROD SEALS
- NO OIL INSIDE ENGINE
- POTENTIAL FOR GRACEFUL DEGRADATION
- POWER OUTPUT FLEXIBILITY

FIGURE 1.- WHY FREE-PISTON STIRLING?

BRAYTON		STIRLING	
TURBINE INLET TEMPERATURE	0183 °K	ENGINE INLET TEMPERATURE	1089 °K
COMP. INLET TEMPERATURE	321 °K	CYCLE TEMPERATURE RATIO	2.5
COMP. PRESSURE RATIO	1.7	ENGINE EFFICIENCY (ALTERNATOR OUT./HEAT IN)	64% OF CARNOT
RECUP. EFFECTIVENESS	0.97	ENGINE SPECIFIC MASS	7.0 KG/KW

(A) SOLAR DYNAMIC SYSTEMS PARAMETERS.

BRAYTON		STIRLING	
REACTOR OUTLET TEMPERATURE	1100 °K	REACTOR OUTLET TEMPERATURE	1100 °K
TURBINE INLET TEMPERATURE	1091 °K	CYCLE TEMPERATURE TEMPERATURE	2.0
COMP. INLET TEMPERATURE	436 °K	ENGINE EFFICIENCY (ALTERNATOR OUT./HEAT IN)	64% OF CARNOT
COMP. PRESSURE RATIO	1.8	ENGINE SPECIFIC MASS	6.0 KG/KW
RECUP. EFFECTIVENESS	0.860		

(B) NUCLEAR DYNAMIC SYSTEMS PARAMETERS.

FIGURE 2.- DYNAMIC SYSTEMS PARAMETERS.

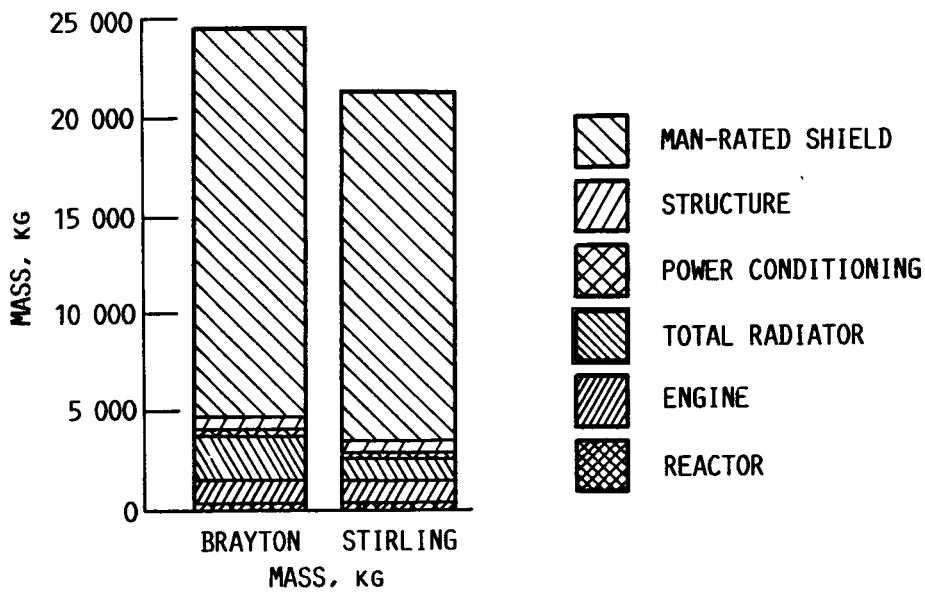

FIGURE 3. - NUCLEAR DYNAMIC SYSTEM MASS. NEW POWER OUTPUT = 150 KWE; REACTOR TEMPERATURE = 1100 K. DOSE RATES: AT HABITAT = 4 MREM/HR (30 M); IN OPPOSITE DIRECTION FROM HABITAT = 200 MREM/HR (30 M).

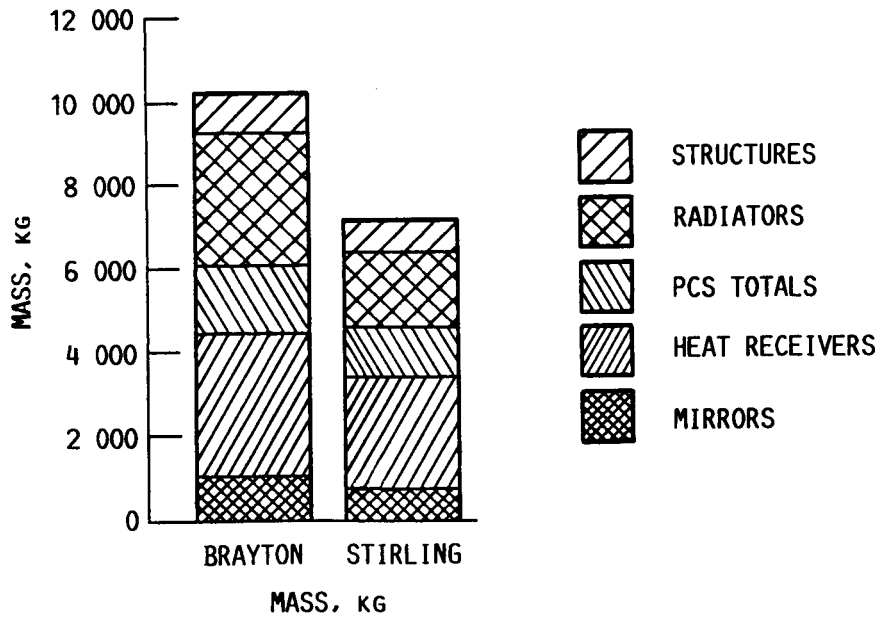

FIGURE 4. - SOLAR DYNAMIC SYSTEMS MASS. NET POWER OUTPUT = 160 KWE. EACH BAR REPRESENTS 4 - 40 KWE POWER SYSTEMS.

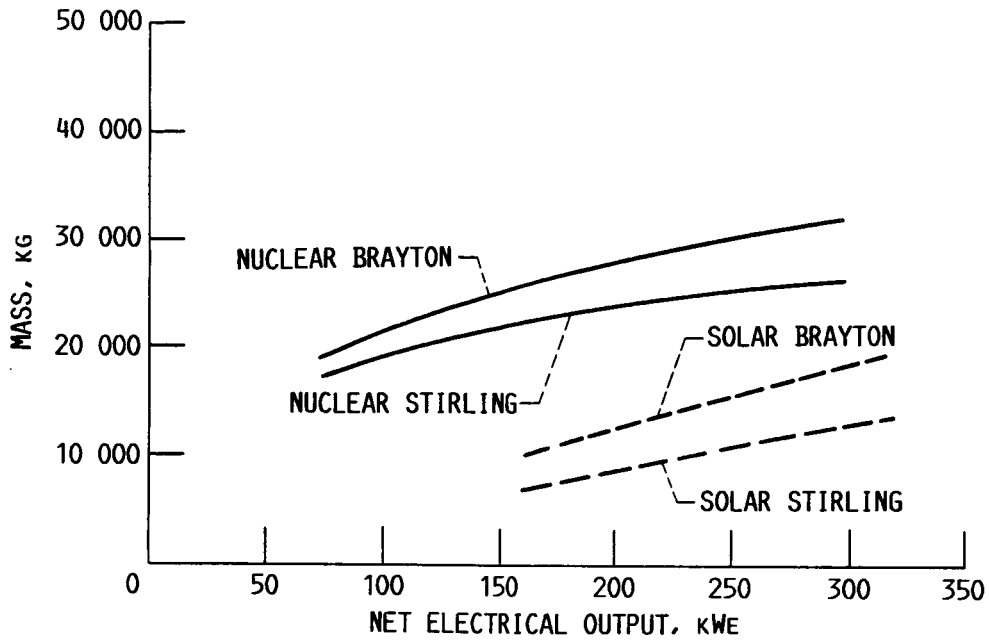

FIGURE 5. - TOTAL SYSTEM MASS FOR POTENTIAL SPACE STATION POWER SYSTEMS.

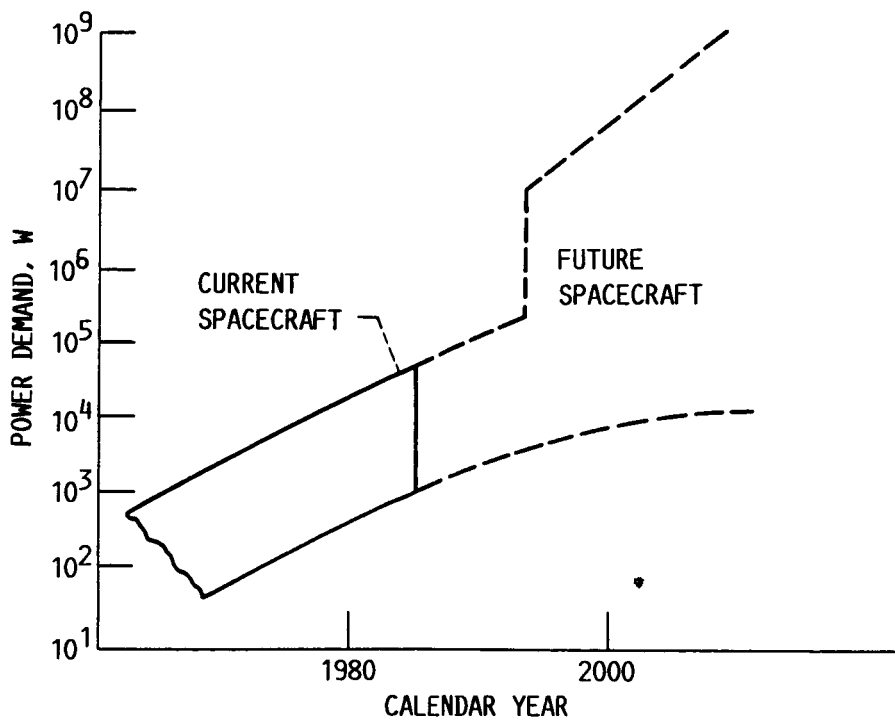
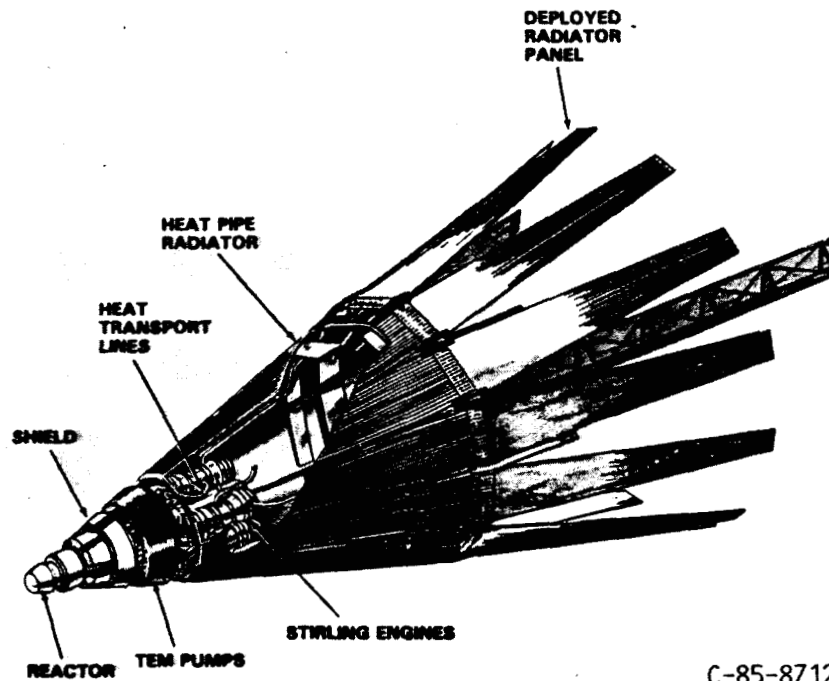

FIGURE 6. - PLANNED SPACE POWER PROGRAMS ADDRESS SPACECRAFT GROWTH.

ORIGINAL PAGE IS
OF POOR QUALITY



C-85-8712

FIGURE 7. - ARTIST'S CONCEPTION OF SP-100 STIRLING SYSTEM.

- DETERMINE DESIGN FEASIBILITY OF SINGLE-CYLINDER FPSE-LA IN THE 150 kWe RANGE
- ESTABLISH PARAMETRIC RELATIONSHIPS
 - PERCENT CARNOT CYCLE EFFICIENCY VERSUS SPECIFIC MASS AT TEMPERATURE RATIO AND POWER RANGE
- ASSESS PROMISING ALTERNATIVE STIRLING CONFIGURATIONS
- AWARD OPTIONS
 - REPEAT STUDY FOR ALTERNATE CONFIGURATION
 - CONDUCT DESIGN OF HIGH POWER SYSTEM
 - DETERMINE MAXIMUM POWER; BEYOND 150 kWe

Figure 8. - Space power FPSE scaling study.

ORIGINAL PAGE IS
OF POOR QUALITY

SUPPORTS KEY TECHNOLOGY AREAS NEEDED FOR:

- GAS BEARINGS
- LINEAR ALTERNATORS
- ALTERNATIVE POWER EXTRACTION
- CODE VALIDATION AND ANALYSIS
- OSCILLATING FLOW
- PERFORMANCE PREDICTIONS
- SCALING
- HEAT EXCHANGERS
- MATERIALS
- POWER CONDITIONING INTERFACE
- LONG LIFE VALIDATION

FIGURE 9.- LEWIS ADVANCED TECHNOLOGY PROGRAM.

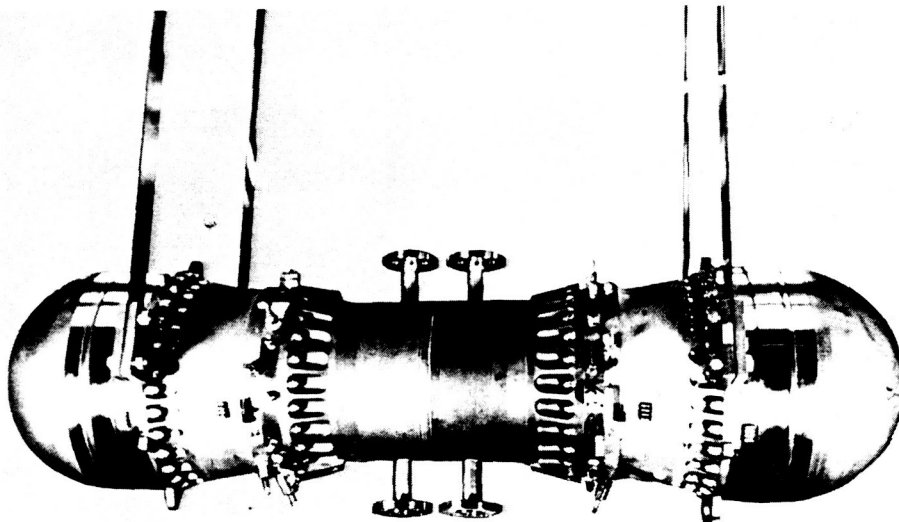

C-85-7371

FIGURE 10. - 25 kW SPACE POWER DEMONSTRATOR ENGINE (SPDE) AT
MECHANICAL TECHNOLOGY INC.

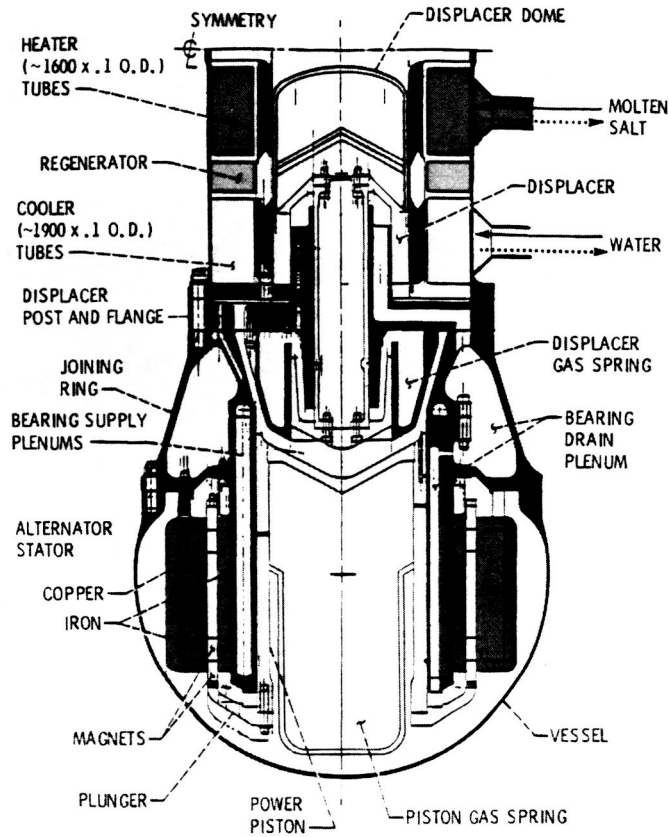

FIGURE 11. - 25 kWE SPDE.

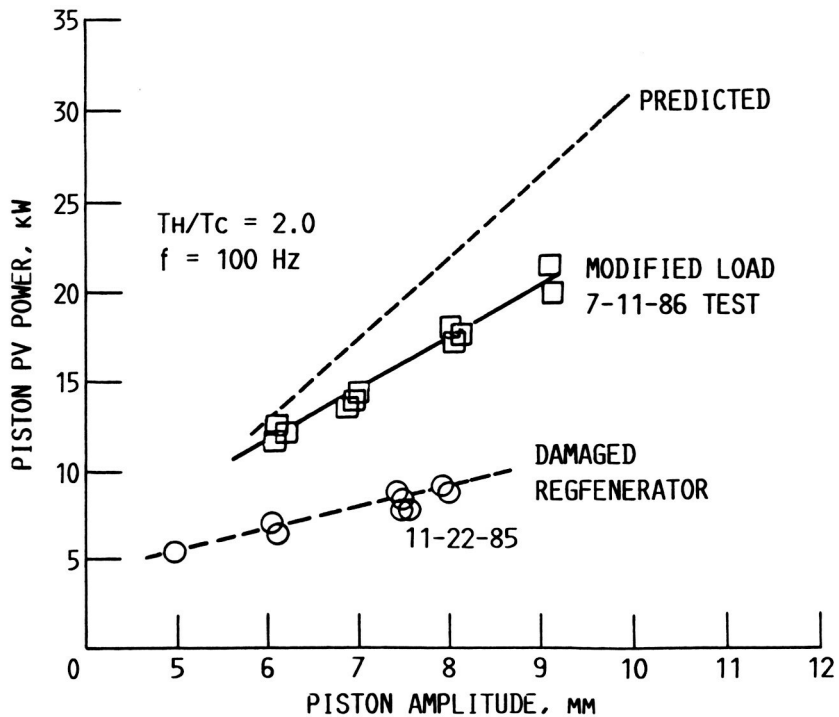
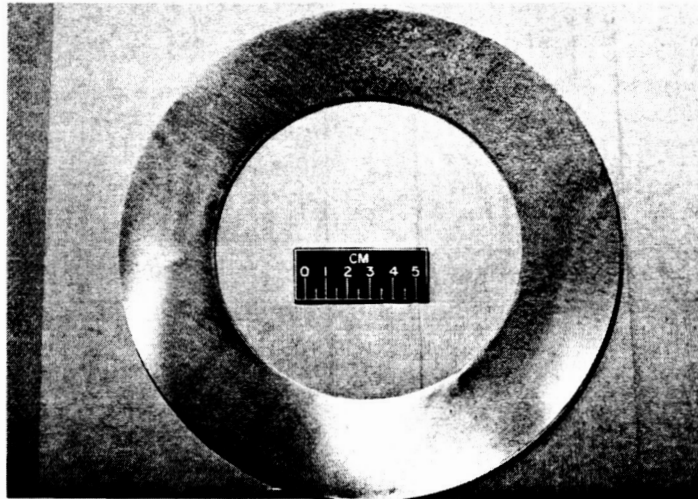
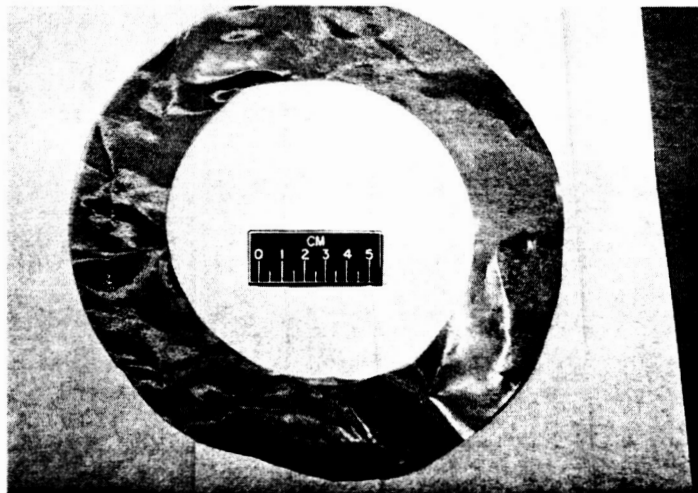

FIGURE 12. - SPDE PV POWER AT 150 BAR.

ORIGINAL PAGE IS
OF POOR QUALITY



BEFORE 105 Hz OPERATION



AFTER 20 HR OF 105 Hz OPERATION

FIGURE 13. - COMPARISON OF SCREEN REGENERATORS.

ORIGINAL PAGE IS
OF POOR QUALITY

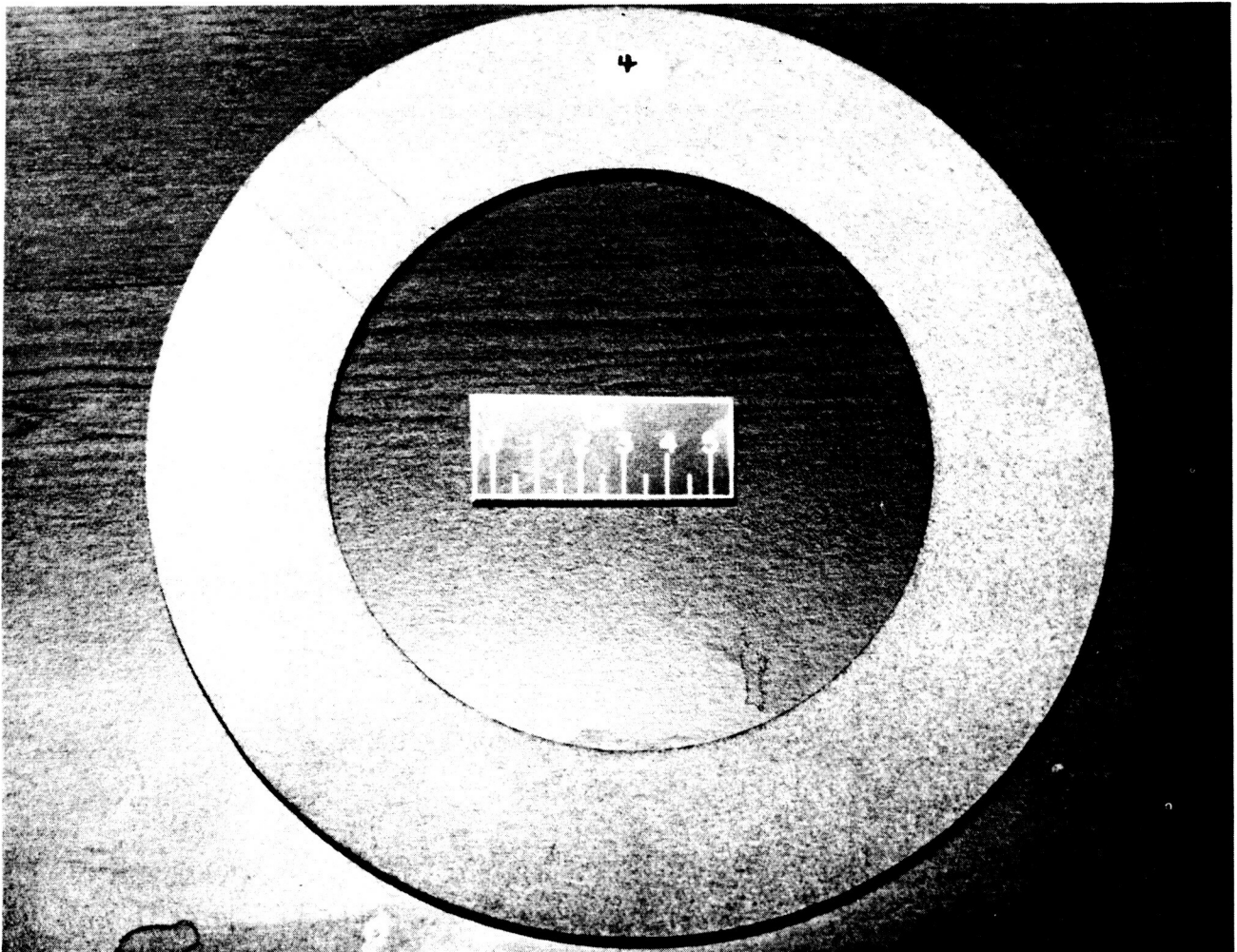

FIGURE 14. - REGENERATOR COMPOSED OF ONE MIL-DIAMETER SINTERED WIRE.

REFRACTORY VERSUS SUPERALLOY

	REFRACTORY	SUPERALLOY
SPECIFIC MASS, KG/KW	5.8	5.5
ALTERNATOR POWER OUTPUT, KW	25	25
ENGINE SYSTEM EFFICIENCY (INCLUDES ALTERNATOR EFF.)	28.5%	29.5%
PERCENT CARNOT EFFICIENCY ($T_R = 2.0$)	57%	59%
HEAT TRANSPORT SYSTEMS:		
• HOT END	PUMPED LOOP	HEAT PIPE
• COLD END	PUMPED LOOP	PUMPED LOOP
HEATER TEMPERATURES:		
• MAXIMUM	1130 °K	1080 °K
• AVERAGE	1080 °K	1080 °K
AVERAGE COOLER TEMPERATURES	540 °K	540 °K

FIGURE 15.- 25 KWE SINGLE CYLINDER SPACE STIRLING ENGINE REFERENCE DESIGNS.

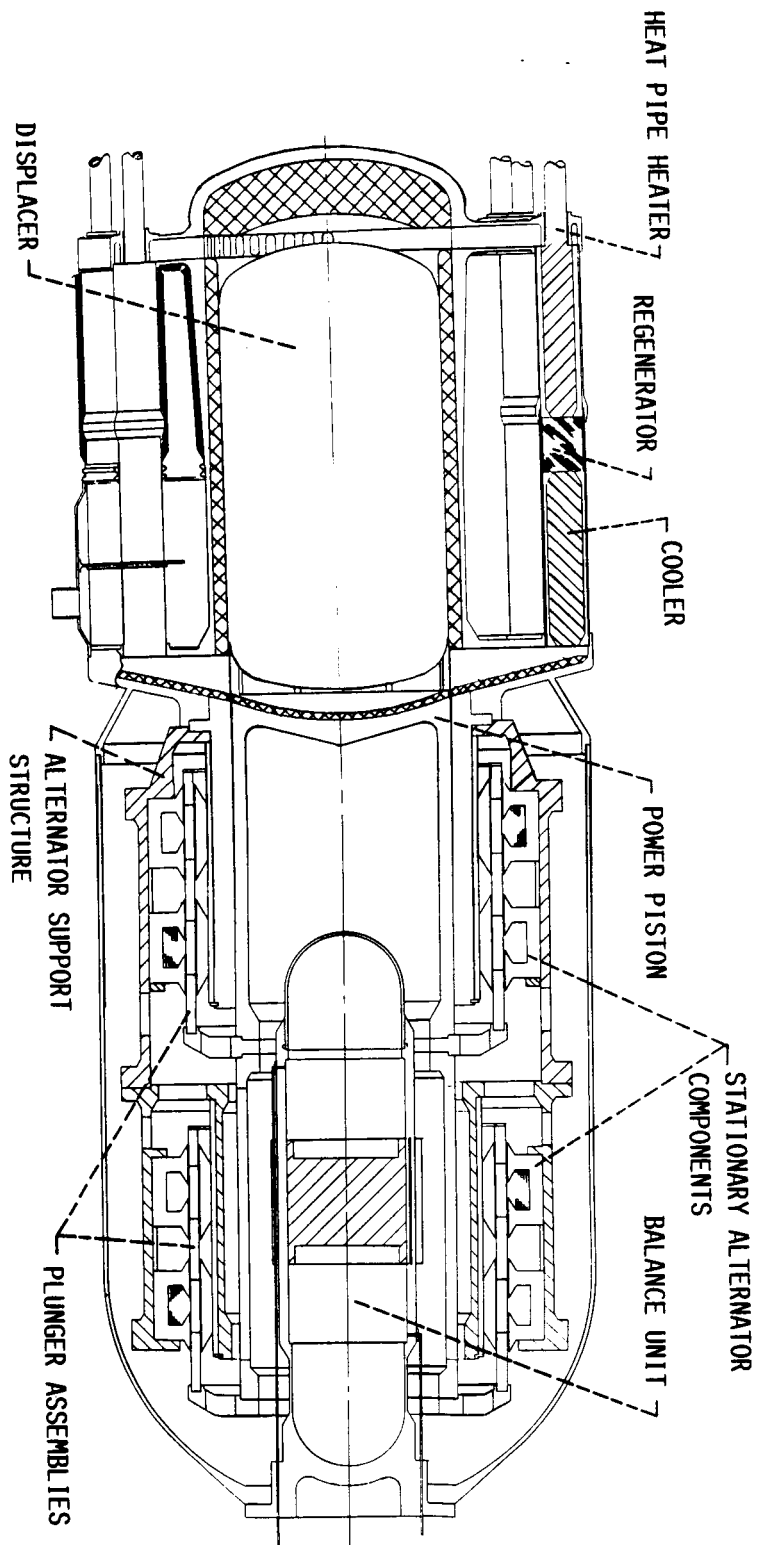

FIGURE 16. - SUPERALLOY REFERENCE DESIGN.

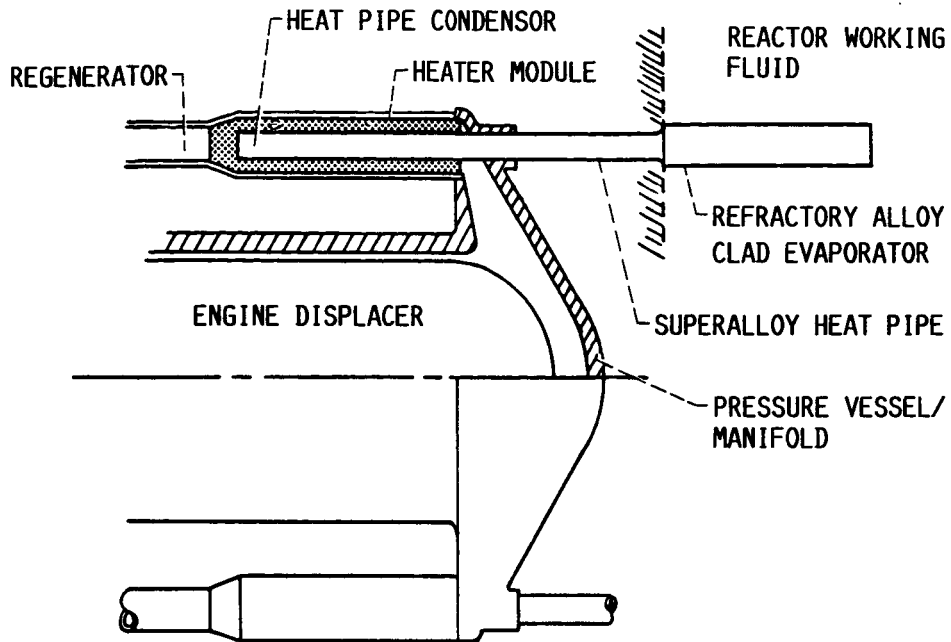

FIGURE 18. - HEATER MODULE - HEAT PIPE ARRANGEMENT.

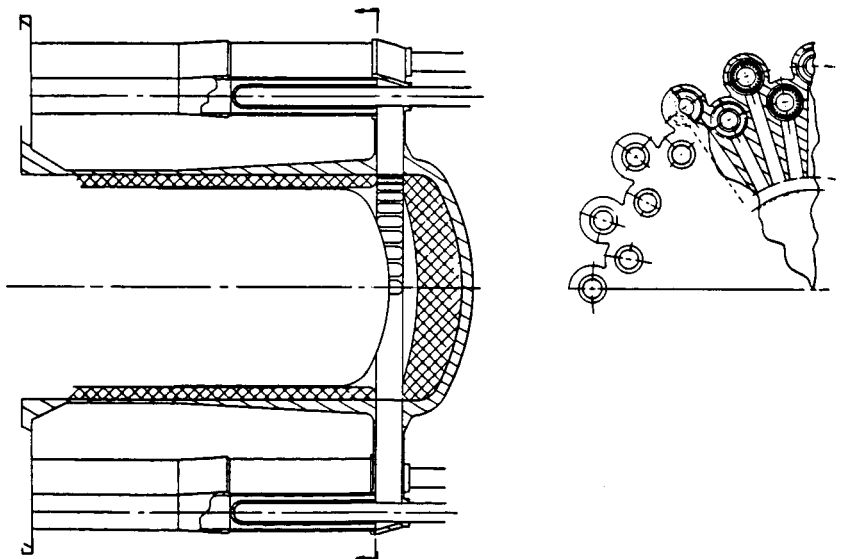
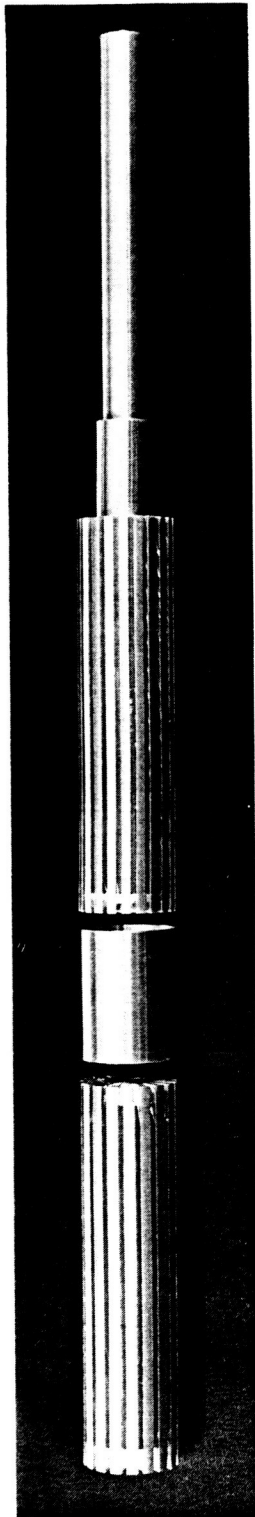
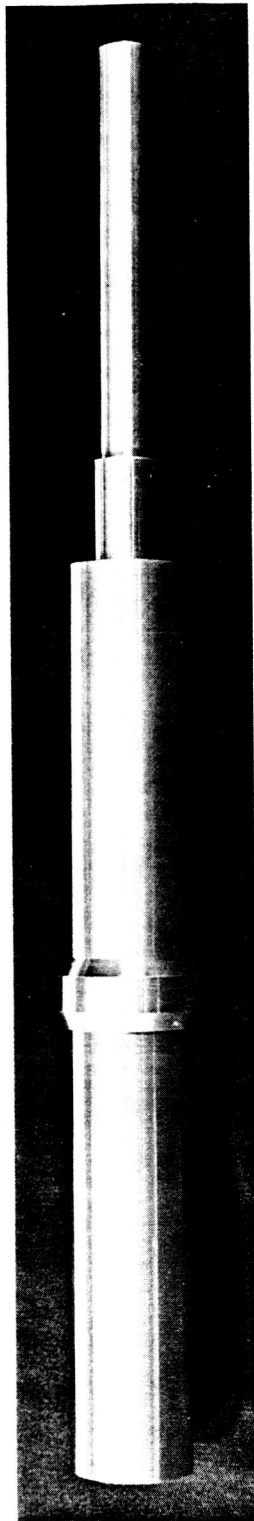

FIGURE 19. - HEAT PIPE HEATER CONFIGURATION.



(A) HEAT EXCHANGER MODULE ASSEMBLY.



(B) HEAT EXCHANGER MODULE.

FIGURE 17. - HEAT PIPE HEATER-REGENERATOR-COOLER.

ORIGINAL PAGE IS
OF POOR QUALITY

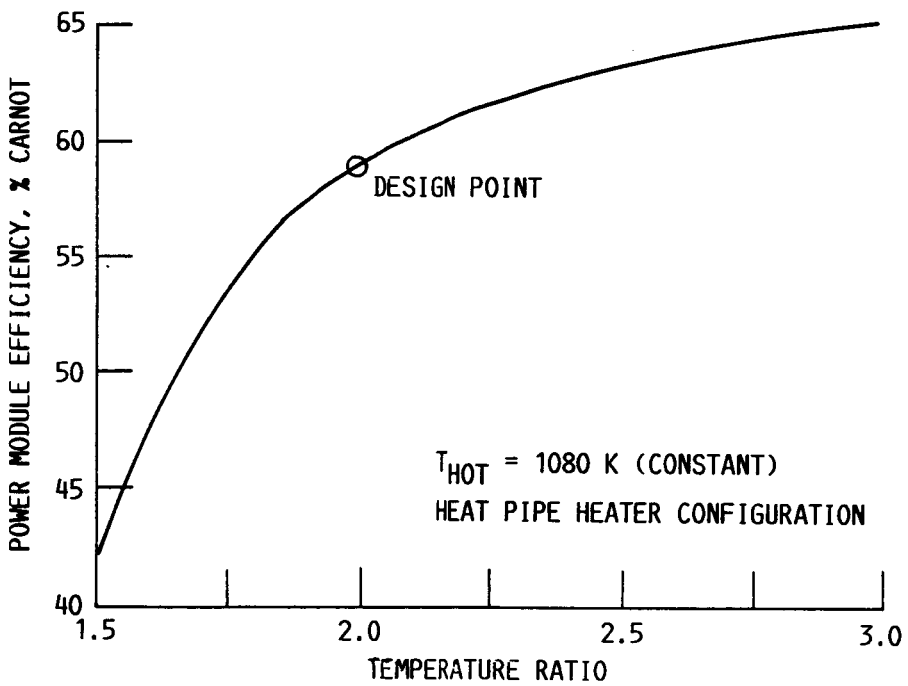
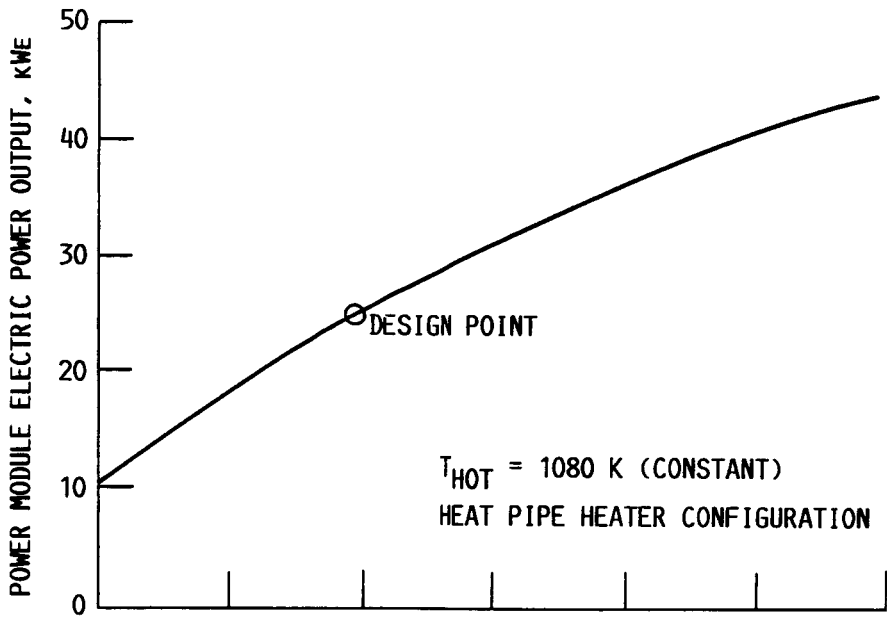

FIGURE 20. - IMPACT OF COLD-END TEMPERATURES ON PERFORMANCE.

- HEAT PIPE HEATER
- DESIGN OPTIMIZATION FOR SPACE APPLICATION
- SIMPLIFIED MODULAR HEAT EXCHANGERS
- HYDRODYNAMIC SPIN LUBRICATED GAS BEARINGS
- 400 °K INCREASE IN HEATER TEMPERATURE; TEMPERATURE RATIO = 2.0; 1080 °K
- SEPARATE RADIATOR TO COOL ALTERNATOR MAGNETS
- POWER PER CYLINDER UP FACTOR OF 2
- SINGLE CYLINDER ACTIVE DYNAMIC BALANCE
- USE OF LIQUID METAL
- REDUCED SPECIFIC MASS > 30%

FIGURE 21.- 25 kW SUPER ALLOY STIRLING SPACE ENGINE (SSE) TECHNOLOGY ADVANCES OVER SPDE.

1. Report No. NASA TM-88886		2. Government Accession No.		3. Recipient's Catalog No.	
4. Title and Subtitle Overview of Free-Piston Stirling Engine Technology for Space Power Application				5. Report Date	
				6. Performing Organization Code 506-41-3A	
7. Author(s) Jack G. Slaby				8. Performing Organization Report No. E-3295	
				10. Work Unit No.	
9. Performing Organization Name and Address National Aeronautics and Space Administration Lewis Research Center Cleveland, Ohio 44135				11. Contract or Grant No.	
				13. Type of Report and Period Covered Technical Memorandum	
12. Sponsoring Agency Name and Address U.S. Department of Energy Division of Building and Community Systems Washington, D.C. 20545				14. Sponsoring Agency Code Report No. DOE/NASA/1005-12	
15. Supplementary Notes Final Report. Prepared under Interagency Agreement DE-AI05-820R1005. Prepared for Solar Energy Conference cosponsored by ASME, JSME, and JSES, Honolulu, Hawaii, March 22-27, 1987.					
16. Abstract An overview is presented of the National Aeronautics and Space Administration (NASA) Lewis Research Center (LeRC) free-piston Stirling engine activities directed toward space-power application. Free-piston Stirling technology is applicable for both solar and nuclear powered systems. As such, the NASA Lewis Research Center serves as the project office to manage the newly initiated SP-100 Advanced Technology program. This program provides the technology push for providing significant component and subsystem options for increased efficiency, reliability and survivability, and power output growth at reduced specific mass. One of the major elements of the program is the development of advanced power conversion of which the Stirling cycle is a viable candidate. Under this program the status of the 25 kWe opposed-piston Space Power Demonstrator Engine (SPDE) is presented. Included in the SPDE discussion are initial differences between predicted and experimental power outputs and power output influenced by variations in regenerators. Technology work is also conducted on heat-exchanger concepts, both design and fabrication, to minimize the number of joints as well as to enhance the heat transfer in the heater. Design parameters and conceptual design features are also presented for a 25 kWe, single-cylinder free-piston Stirling space-power converter. Projections are made for future space-power requirements over the next few decades along with a recommendation to consider the use of dynamic power-conversion systems—either solar or nuclear. A cursory comparison is presented showing the mass benefits that a Stirling system has over a Brayton system for the same peak temperature and output power. A description of a study to investigate the feasibility of scaling a single-cylinder free-piston Stirling space-power module to the 150 kWe power range is presented. The work discussed in this paper is synergistic with the NASA Advanced Solar Dynamic Program where NASA Lewis is conducting research on advanced concentrator, receiver and thermal energy storage systems at temperatures around 1000 K for Stirling and Brayton cycle power conversion systems.					
17. Key Words (Suggested by Author(s)) Free-piston; Stirling engine; Space power				18. Distribution Statement Unclassified - unlimited STAR Category 85 DOE Category UC-96	
19. Security Classif. (of this report) Unclassified		20. Security Classif. (of this page) Unclassified		21. No. of pages	22. Price*