

*NASA Conference Publication 2476*

# Spacecraft Fire Safety

*Proceedings of a workshop held at  
NASA Lewis Research Center  
Cleveland, Ohio  
August 20-21, 1986*

**NASA**

National Aeronautics and  
Space Administration

**Scientific and Technical  
Information Branch**

1987

## FOREWORD

Fire safety has always had a high priority in the planning and operation of human spacecraft missions. With the designs under way for a permanently inhabited United States orbiting facility, the NASA Space Station, new issues of fire safety must be addressed. These involve, on the one hand, more stringent requirements because of the long-term habitation of the Space Station and, on the other hand, more flexible requirements because of the goal of accessibility to a variety of users. Thus the challenge to spacecraft fire safety planners is to meet these potentially contradictory objectives without compromising basic human or structural safety.

The purpose of the workshop documented in this publication was to review the current knowledge in fire safety and to assess the needs relevant to spacecraft. The cooperation of the authors and the other participants in sharing their knowledge in the papers and the discussion forums is most appreciated. The chairman also acknowledges the support of the editor, Janice Margle, of the Pennsylvania State University, Ogontz Campus, in condensing the minutes of the discussion forums and organizing this publication.

I hope that this material will prove to be informative and useful to many readers.

Robert Friedman  
Workshop Chairman  
NASA Lewis Research Center

PRECEDING PAGE BLANK NOT FILMED

## CONTENTS

	Page
FOREWORD . . . . .	.111
EXECUTIVE SUMMARY . . . . .	1
INTRODUCTION . . . . .	7
TECHNIQUES FOR FIRE DETECTION - Richard W. Bukowski, Center for Fire Research, National Bureau of Standards . . . . .	9 <sup>51</sup>
FIRE-RELATED STANDARDS AND TESTING - Vytenis Babrauskas, Center for Fire Research, National Bureau of Standards . . . . .	31 <sup>52</sup>
FIRE EXTINGUISHMENT AND INHIBITION IN SPACECRAFT ENVIRONMENTS John de Ris, Factory Mutual Research . . . . .	43 <sup>53</sup>
INERTING AND ATMOSPHERES Homer W. Carhart, Naval Research Laboratory . . . . .	51 <sup>54</sup>
FIRE-RELATED MEDICAL SCIENCE Douglas R. Knight, Naval Submarine Medical Research Laboratory . . . . .	59 <sup>55</sup>
AIRCRAFT FIRE SAFETY RESEARCH Benito P. Botteri, Air Force Wright Aeronautical Laboratories, Aero Propulsion Laboratory . . . . .	65 <sup>56</sup>
SPACE STATION INTERNAL ENVIRONMENTAL AND SAFETY CONCERNS Matthew B. Cole, NASA Lyndon B. Johnson Space Center . . . . .	73 <sup>57</sup>
MICROGRAVITY COMBUSTION FUNDAMENTALS Kurt Sacksteder, NASA Lewis Research Center . . . . .	89 <sup>58</sup>
SPACECRAFT MATERIAL FLAMMABILITY TESTING AND CONFIGURATIONS Paul W. Ledoux, McDonnell Douglas Astronautics Company, Houston Operations . . . . .	95 <sup>59</sup>
IGNITION AND COMBUSTION OF METALS IN OXYGEN Frank J. Benz, NASA JSC White Sands Test Facility, and S. Zhu, Lockheed Engineering and Management Services Company . . . . .	99 <sup>56</sup>
FORUM 1 - FIRE DETECTION AND IGNITION . . . . .	.103
FORUM 2 - FIRE EXTINGUISHMENT . . . . .	.105
FORUM 3 - HUMAN RESPONSES TO COMBUSTION PRODUCTS AND INERT ATMOSPHERES . . . . .	.109
FORUM 4 - SPACECRAFT MATERIALS AND CONFIGURATIONS . . . . .	.111

PRECEDING PAGE BLANK NOT FILMED

FORUM 5 - SELECTION OF SPACECRAFT ATMOSPHERES . . . . .115  
REFERENCES . . . . .119

Omit TO  
P. 9

## EXECUTIVE SUMMARY

This publication contains the presentations and findings of the Spacecraft Fire Safety Workshop held at the NASA Lewis Research Center, August 20-21, 1986. The workshop consisted of, first, a symposium with 10 original survey papers relating to fire safety. Following the symposium were five simultaneous forums, which discussed applications of fire safety principles to spacecraft and recommended issues for further studies.

### Review Papers

Techniques for fire detection. - The purpose of a fire detector is to provide the earliest warning of an unwanted fire, balanced against the avoidance of false alarms. The detector responds to fire signatures, which are environmental departures from normal conditions indicative of fires. Signatures are broadly classified according to categories of heat, smoke, and light (or radiation); and the application of fire detectors must consider not only the response to the signatures but also the time-dependent transport of the signature mass or energy to the detector. Common and advanced types of detectors, their principles and applications, are illustrated and discussed in the paper. The selection of a detector and a detecting system depends on the application cost, response, and other factors. The prediction of fire growth through analytical modeling is a modern practice that is invaluable in matching fire detectors to anticipated fire hazards.

Fire-related standards and testing. - Until recently, flammability test methods tended to be empirical procedures, not firmly rooted in an understanding of the fire science. During the last decade, however, bench-scale tests based on physical and chemical phenomena have been devised for systematic and standardized prediction of full-scale fire behavior. New-generation tests, proposed or adopted by standards organizations, evaluate ignitibility, flame spread, and heat and product generation rates. The tests use improved simulation apparatus, for example the NBS Cone Calorimeter, which can determine quantitative ignition, heat release, and smoke generation rates. For the special needs of spacecraft (as contrasted to conventional building and structural test methods), nonambient oxygen concentrations, various total atmospheric pressures, and low gravity may all influence the strategy of testing and the interpretation of results. Present NASA and other aerospace test methods must of necessity assess material flammability at ambient pressure and gravity levels, but future test methods will be expected to focus on fundamental principles related to the space environment.

Fire extinguishment and inhibition in spacecraft environments. - Extrapolation of terrestrial fire protection experience to spacecraft situations demands a thorough scientific understanding of the extinguishing mechanisms. The confined volume, artificial atmosphere, and lack of buoyancy forces in low gravity all influence the fire behavior and the suppression techniques in spacecraft. The current aerospace extinguishant, a halogenated hydrocarbon, Halon 1301, presents the serious technological problem of removal of halogen-acid contaminants in the cabin atmosphere after a fire. The cleanup advantages of alternative extinguishants must be assessed against the efficiency of Halon

1301. For electronic equipment compartments, an inerting mechanism, such as onboard nitrogen generation, would be preferable to reliance on extinguishants. A vigorous argument is presented for consideration of liquid water sprays as fire extinguishers, which, in principle and application, offer promise for practical use in the spacecraft environment.

Inerting and atmospheres. - The spacecraft cabin is an example of an enclosed capsule supporting humans in an exceedingly hostile environment, analogous in many respects to submarines and deep-sea exploration vessels. Research and experience show that human life can be sustained for extended periods in an atmosphere with low oxygen concentrations that inhibit combustion. A considerable body of data exists, albeit taken in normal gravity, that establishes oxygen indices for common materials, that is, the lowest concentration of oxygen to support combustion. For most materials, a small reduction in oxygen concentration is sufficient to insure nonflammability. This principle can be applied to long-term habitation and to emergency extinguishment of fires by flooding with an inert gas, such as nitrogen.

Fire-related medical science. - Crews must inhibit or extinguish fires quickly in spacecraft, because the treatment of fire victims may require medical skills and supplies that exceed the capabilities and resources in the spacecraft. Exposure to overheating can be lethal within a short period of time. More likely hazards are the smoke and toxic gases generated by even minor fires. Carbon monoxide is the most common adverse combustion product, but synthetic polymers in spacecraft may generate cyanides, halogen acids, ammonia, and other toxic products. Other fire injuries can result from overpressure and structural failure caused by explosions through ignition of reactive gaseous products. Medical science applicable to spacecraft fire safety should study permissible limits of exposure to toxic substances based on human mental acuity and judgment tests to include the psychology of escape. The strategy of fire safety through the use of a reduced-oxygen atmosphere has much promise, but its implementation requires additional medical-related research on human effects in unusual atmospheres.

Aircraft fire safety research. - Although aircraft fire safety problems are more diversified than those anticipated in spacecraft, the space field can benefit from the experience and improvements gained from aircraft techniques. Aircraft fire threats involve a variety of materials and operating environments. The major fire hazard may arise from the storage and usage of low-flash-point and kerosene-type fuels. The dangers from fuel fires have led to studies and applications in fuel tank protection and inerting, crash-fire protection, armament and explosion protection, heat-absorbing fuels (endothermic fuels), and improved-property hydraulic fluids. Engine compartments and nacelles employ advanced concepts in fire detection and automated extinguishing systems, all worthy of consideration for spacecraft adaptation. Fire standards for materials, detection, extinguishment, and escape in aircraft cabins also provide analogies for consideration in spacecraft fire control measures.

Space Station internal environmental and safety concerns. - The proposed U.S. Space Station will present unique problems in fire safety because of its long lifetime, limited resources, hazardous operating conditions, and crew of varying skills. The Space Station will consist of differing protected volumes, comprising habitation, laboratory, and supply modules. The major threat of fire is countered through methodology derived from the previous U.S. manned

spacecraft projects, techniques that provide limited precedents or patterns of growth. Although designs are actively proceeding, the means of fire detection, extinguishment, and escape in the Space Station are still to be determined in detail. The paper discusses current and potential techniques applicable to the Space Station, with some indications of their advantages and disadvantages. It is likely that a combination of fire detection and extinguishment methods will be used in the diverse modules of the Space Station. The concept of module venting for uncontrollable fires or post-fire atmospheric clean-up must be considered as an alternative means of fire control.

Microgravity combustion fundamentals. - In normal gravity, fire spreads to a large extent through the bulk density gradients created by the rapid heat release. This natural convection is absent in microgravity (the low gravity in orbiting spacecraft), although bulk fluid and energy transport continues through diffusion, radiation, pressure gradients, and forced convection (ventilation). The simplification of the combustion process by removal of the gravity force has motivated low-gravity combustion research in order to understand the subtleties of normal-gravity flame spreading. For fire safety considerations, the role of the low-gravity environment is ambiguous. On the one hand, microgravity flame spread may be less than corresponding normal-gravity flame spread because of limited oxidant diffusion and poor combustion efficiency. On the other hand, microgravity combustion may be enhanced by the action of otherwise weak flow fields in the spacecraft atmosphere, by radial expulsion of melting materials, and by increased radiation from sooty flames. Ground-based low-gravity testing is indispensable to the understanding of microgravity combustion. For this purpose, specialized facilities include drop towers and Keplerian-orbit airplane trajectories.

Spacecraft material flammability testing and configurations. - NASA has imposed strict flammability requirements on all spacecraft materials, as provided in a handbook on test procedures. The acceptance of designs, materials, or configurations is based on a formalized design process for tracking and control. Realism in the approach to material safety requires the adoption of a philosophy that (1) an ignition source exists, and (2) any fire that starts shall be self-extinguishing within a short distance. Inevitably some flammable materials (as defined by the strict test procedures) must be accepted onboard the spacecraft. To conform to the approval philosophy, such materials are either widely spaced in small quantities or stored in nonflammable containers. The special problem of electronic devices and wiring is approached by compartmentalization, fire barriers, or inerting. Major concerns for the near future are those of finding alternatives for the Halon 1301 extinguishant and substitutes for the present flammable materials in clothing, foams, and paper.

Ignition and combustion of metals in oxygen. - Metals are normally more difficult to ignite than flammable gases and nonmetals because metals have higher densities, thermal conductivities, and ignition temperatures. In spacecraft, however, the presence of oxygen in life-support systems and in combination with fuels for propellant systems can lead to catastrophic metal ignition and metal-oxygen combustion. The oxide coating that adheres to metal surfaces can act as a barrier to ignition. The ignition process is thus not only influenced by the type of metal but also by the physical nature of the oxide, dynamic conditions (impact), and oxygen pressure. Metals can burn as either vapors or liquids, depending on the metal boiling point and the flame

temperature. In low gravity, combustion of metals as liquids or vapors may be influenced by the elimination of convective flows that could detach molten masses or vapors, exposing fresh metal surfaces. In any case, metal fires generate more heat per unit volume than conventional fires, and they are best controlled by strict prevention of ignition rather than by attempts at extinguishment.

#### Discussion Forums

Fire detection and ignition. - The general findings of this forum can be summarized in the single statement that rapid detection of incipient hazards is imperative. Thus overheating, a precursor to ignition, should be detected, perhaps through indicator coatings on critical equipment. Hazard discrimination can be aided by multiple sensing to identify threats and avoid false alarms through pattern logic, or by sensing in several locations through a common detector system. More specific information on hazards in the Space Station, which will have uninhabited as well as inhabited modules, must be provided. The recommendations for research and technology from this forum are

- (1) Study of detection of overheated and smoldering components, with emphasis on the development of heat-sensitive coatings
- (2) Improvement of sensing systems, and incorporation of multiple fire-signature decision software
- (3) Development of central detector systems for command of localized sensing stations
- (4) Study of fire signatures expected in low gravity and nonstandard atmospheres
- (5) Inventory of spacecraft equipment and procedures to anticipate hazards and locate sensors

Fire extinguishment. - The general findings of this forum cover both fundamental research needs and applied technology needs. In fundamentals, further studies of chain-reaction models in the role of extinguishment are essential, particularly those directed toward low-gravity environments, deep-seated and smoldering combustion. In applications, alternatives to the present Halon 1301 extinguishant are desirable, with the emphasis on water and nitrogen. The cleanup of inhabited areas to remove post-fire residues and atmospheric pollutants is a neglected aspect of fire control. The recommendations for research and technology from this forum are

- (1) Fundamental research on combustion and suppression in microgravity and space-unique environments
- (2) Testing and evaluation of candidate extinguishants
- (3) Development of specific extinguishment and inerting techniques for hazardous areas of the spacecraft



- (4) Planning for post-fire atmospheric cleanup
- (5) Establishment of cooperative working groups to pursue analogies between space and submarine research

Human responses to combustion products and inert atmospheres. - The general findings of this forum can be summarized in the statement that further investigative and statistical information on human hazards in enclosed environments must be obtained. Human standards for tolerance of atmospheric contaminants from all sources need to be improved. Material standards for fire safety should include the determination of pyrolytic generation of toxic products as well as absolute flammability. The forum concurs with the view that low-oxygen "fire-safe" atmospheres may be suitable to support human activities. Finally, the forum notes that one must recognize human failings, that is, the tendency to overlook fire rules and bring contraband on board spacecraft. The recommendations for research and technology from this forum are

- (1) Revision of material acceptance standards to test toxicology of emission products
- (2) Emphasis on human responses in establishing fire safety policies
- (3) Study of combustion, pyrolysis, and extinguishment products expected in microgravity
- (4) Update of human tolerance limits to pollutants and reduced-oxygen atmospheres
- (5) Designation and training of at least one spacecraft crewmember as a fire marshal on each mission

Spacecraft materials and configurations. - The general findings of this forum center on the need for improved material assessments for the long-life Space Station. New concerns should include material aging and changes, non-visible combustion or smoldering, and the proper containment of hazardous materials. Particular problems, such as the increased flammability in the enriched-oxygen spacecraft atmosphere prior to an extravehicular activity, must be recognized. The forum also notes the importance of the application of established knowledge in aircraft and ground fire safety to spacecraft. The recommendations for research and technology from this forum are

- (1) Further flammability testing in low-gravity environments
- (2) Further testing on overheating and product generation from common materials
- (3) Further long-term material testing to include aging effects
- (4) Establishment of data banks to share and correlate space, aircraft, and ground fire models

Selection of spacecraft atmospheres. - The general findings of this forum are that research on spacecraft cabin atmospheres is warranted, first, to develop fire-safe atmospheres and, second, to learn about contamination from

fire extinguishment. Three alternative fire-safe atmospheres are proposed. The first-priority recommendation is an increased total pressure oxygen-nitrogen atmosphere, which has a near-normal oxygen partial pressure but a reduced oxygen mole fraction. The second is a sea-level total pressure oxygen-nitrogen atmosphere, with a reduced oxygen partial pressure and mole fraction. The third is an oxygen-diluent atmosphere, where the inert component is a high-heat-capacity gas (carbon tetrafluoride is an example). On the topic of post-fire atmospheric contamination, the forum notes the advantages of water over Halons and other common extinguishing agents. Other topics of forum discussion are fire spread through ventilated forced convection, effects of alternative atmospheres on equipment performance, and isolation and inerting of high-risk volumes. The recommendations for research and technology from this forum are:

- (1) Research and technology programs on the three alternative spacecraft cabin atmospheres
- (2) Research on combustion, pyrolysis, and smoldering in all atmospheres
- (3) Establishment of data banks to collect knowledge on fire behavior in unusual environments
- (4) Further research on atmospheric contamination by extinguishants

## INTRODUCTION

It is recognized that overheating, fire, explosion, and the resulting byproducts can be extreme hazards in inhabited spacecraft. With designs underway for a permanently inhabited orbiting facility, the NASA Space Station, new issues of fire safety must be addressed (refs. 1 to 3). The Space Station must serve as a self-contained community, with hope of rescue many days away. The Space Station will accommodate a crew with various skills engaged in construction and maintenance, scientific experiments, and commercial technology development, as well as ordinary living, housekeeping, and recreational activities. Thus, the Space Station may call for improved and innovative fire safety strategies, as compared to previous space flight programs. On the other hand, it is important to make the Space Station as accessible as possible to a variety of users. Accordingly, fire safety measures must strive for simplicity, flexibility, generalization, and cost effectiveness, without compromising human or structural safety criteria.

The primary emphasis in past human-crew space missions has been on fire protection through control and selection of onboard materials (ref. 4). The underlying philosophy is that ignition sources will exist, but fires must be self-limiting within a short distance from their ignition points (ref. 5). Non-self-extinguishing materials brought onboard spacecraft (paper, clothing, for example) must be made fire-limiting by spacing of materials or containment in fire-resistant enclosures. For the Space Station, and to some extent the Shuttle Orbiter, rigid material and configuration controls are not sufficient for fire safety. Fire detection and suppression measures must be incorporated into present and future designs.

Attention to the particular needs of spacecraft fire safety dates to the early space projects (ref. 6). More recent attention has involved the NASA Lewis Research Center, where programs have included research on microgravity (low-gravity) combustion and propellant safety, and management of an aerospace safety data institute. The Lewis Research Center cooperated with the NASA Johnson Space Center for a spacecraft fire safety review in March 1984. The principal questions leading to this review were those of enriched-oxygen atmosphere hazards and extinguisher toxicity in spacecraft cabins, but the meeting expanded the themes to cover low-gravity combustion, fire control, and medical science. The review findings were informal and unpublished. However, the recommendations for further inquiry into selected fire-safety topics, impelled by the needs of the developing Space Station program, stimulated the organization of a second review. This meeting, the NASA Spacecraft Fire Safety Workshop, was held at the NASA Lewis Research Center on August 20-21, 1986.

The workshop program was divided into two sections. The first section was a day-long symposium on subjects relating to fire safety, fundamental and applied, and to the spacecraft environment. The second section was a set of five simultaneous discussion forums on the relevant topics of fire detection, fire extinguishment, human responses, spacecraft materials, and spacecraft atmospheres. The workshop leaders and participants could attend any forum of their choice. Each forum provided an opportunity to discuss the application of fire safety principles to spacecraft needs, the problems anticipated in the

Space Station, and the recommendations for future research, technology, and standards.

This publication is a summary of the NASA Lewis Spacecraft Fire Safety Workshop, consisting of the 10 papers and the minutes of the discussion forums. The papers are furnished by the various authors as expanded versions of the oral presentations given at the workshop. Occasional inconsistencies between the papers represent genuinely differing points-of-view in the fire-safety field. The discussion forum chapters are based on a consensus of the participants' discussion as written by the workshop editor from documents submitted by the forum leaders.

A condensation of the workshop recommendations is included in a recent paper on spacecraft fire safety (ref. 7).

## TECHNIQUES FOR FIRE DETECTION

Richard W. Bukowski  
Center for Fire Research  
National Bureau of Standards

## INTRODUCTION

The purpose of a fire detector is to provide the earliest warning possible of the outbreak of an unwanted fire so that appropriate actions to mitigate the consequences of the fire can be taken. These actions generally include the evacuation of occupants at risk to a safe area and the initiation of extinguishment activities, either automatic or manual. Since fires and the threat posed by them grow rapidly, earlier extinguishment means that the threat and potential for damage from the fire is minimized.

Balanced against the desire for rapid activation is the need to minimize false alarms, which disrupt normal activities and erode confidence in the detection system. Detectors that "cry wolf" too often are either ignored or disconnected, resulting in the potential for disaster. In an early 1970's report on Air Force aircraft engine nacelle fire detectors (ref. 8), Fox reported that about 83 percent of the alarms received were false and 50 percent of the fires were not detected. The latter was related to the former in that the high false alarm rate caused the crews to disconnect the detectors in order to meet flight readiness objectives. In commercial building systems, Fry (ref. 9) and Bukowski (ref. 10) both reported false to real alarm ratios of 14:1 for smoke detectors in the United Kingdom and the United States, respectively.

The balance between early warning and minimum false alarms requires that the detector selected be matched to the application in terms of the characteristics of the expected fires and the operating environment. An analysis of the combustible materials and potential ignition sources within a space to be protected can provide insight into the expected "fire signatures" that will be produced. Taking into account the characteristics of the space that will influence the transport of these products from the combustion site to the detector location and the response of the detector type selected allows the prediction of performance. Finally, the vulnerability of the space (and its contents and occupants) should be analyzed to determine the maximum fire size that can be safely tolerated in order to establish the detection goal required to provide a safe condition without being overly sensitive.

The purpose of this paper is to provide an overview of the bases for such an analysis. First, the burning process is discussed in terms of the production of the "fire signatures" normally associated with detection devices. These include convected and radiated thermal energy, particulates, and gases. Second, the transport processes associated with the movement of these from the fire to the detector, along with the important phenomena which cause the level of these signatures to be reduced, are described. Third, the operating characteristics of the individual types of detectors, which influence their

response to the signals, are presented. Finally, vulnerability analysis using predictive fire modeling techniques will be discussed as a means to establish the necessary response of the detection system to provide the level of protection required in the application.

## FIRE SIGNATURES

Fire detectors sense the presence of fire by responding to changes in their local environment that are indicative of a fire within their associated area of coverage. The goal is to select conditions for sensing that appear as early as possible and that are present at levels sufficiently above those at normal, nonfire conditions to minimize false alarms. These changes of conditions are called fire signatures. Various fire conditions may produce different fire signatures, so optimum detector system design requires that the detector types selected must be matched to the hazard present.

### Heat

Combustion is essentially an exothermic, gas-phase chemical reaction. Gaseous fuels combust by breaking bonds in the fuel molecules, forming other chemical species and releasing thermal energy. For solid or liquid fuels, some of the thermal energy is needed to produce the phase change to a gas before the actual combustion takes place. This required energy is the heat of gasification. The net remaining energy then goes to increase the temperature of the gases and air leaving the combustion zone. This hot gas rises due to buoyancy to the ceiling and spreads radially outward in a ceiling jet. The temperature and velocity of this ceiling jet govern the heat transfer rate to thermally activated detectors located on the ceiling.

### Smoke

In terms of fire detection, smoke refers to solid or liquid particles released during combustion. The solids are clusters of carbonaceous spherules formed within the fuel rich portions of the flame in a process similar to polymerization. Vapors can condense on a solid core, yielding a liquid covered smoke particle. This condensation process requires that the temperature be below the vaporization temperature while the vapor concentration is still high. In smoldering combustion, essentially all the smoke is in the form of condensed vapors. This is why the smoke from smoldering appears light colored (the liquid is largely water) and the smoke from flaming is dark (mostly carbon). This also means that the particle size from smoldering is larger than from flaming.

### Light

Flames radiate light energy over a broad spectrum. Radiation in the visible and infrared comes largely from thermal energy radiating from the carbon particles within the flame. This is why a hydrogen flame, which contains no carbon, is invisible. Ultraviolet radiation comes largely from OH radicals, and the thermally broadened OH radiation explains why alcohol flames and pre-mixed gas flames appear blue.

## Transport/Losses

Once produced by the fire, the fire signature must travel to the detector to produce a response. Depending on the signature, this transport process takes time, and losses can occur that further delay response. An understanding of this process can help to select optimum detector placement and type for the fastest response to the hazard.

The rising plume above a fire entrains cool air, which reduces the temperature and dilutes the particulate concentration. Once the plume contacts the ceiling, heat transfer reduces the temperature further, but particulate losses to the ceiling are generally small. When the ceiling jet reaches the detector, the thermal inertia of a heat detector results in a delay in response, but a smoke detector will respond immediately if the particulate concentration is high enough. This is the primary reason why smoke detectors respond faster than heat detectors for most fires.

With flame detectors, the light energy travels in a straight line almost instantaneously. Since the fire is radiating in all directions, the intensity falls off as the square of the distance from the fire to the detector and may be attenuated by any smoke particles in the radiant beam. The key thing to remember about flame detection is that the detector must be able to "see" the flame directly, although infrared energy will reflect from surfaces at a reduced level.

## HEAT DETECTION

### Types

Heat detectors are the oldest type of automatic fire detection device. They began with the development of automatic sprinkler heads in the 1860's and have continued to the present with a proliferation of different types of devices. A sprinkler can be considered a combined extinguishing device and heat-activated fire detector when the sprinkler system is provided with water flow indicators tied into the fire alarm control unit system. These water flow indicators detect either the flow of water through the pipes or the subsequent pressure drop upon actuation of the system and automatically sound an alarm as the water is being put on the fire.

Electrical heat detectors, which only sound an alarm and have no extinguishing function, are also used. Heat detectors are the least expensive fire detectors, have the lowest false alarm rate of all fire detectors, but are also the slowest in detecting fires. Heat detectors are best suited for fire detection in small confined spaces where rapidly building, high heat output fires are expected and in other areas where ambient conditions would not allow the use of other fire detection devices or where speed of detection or life safety are not the prime consideration. One example of this would be low value protection where fire could cause minimum damage to the structure or contents. Heat detectors may be thought of as detecting fires within minutes of ignition.

Heat detectors respond to the convected thermal energy of a fire and are generally located at or near the ceiling. They may respond either at a predetermined fixed temperature or at a specified rate of temperature change.

In general, heat detectors are designed to sense a prescribed change in a physical or electrical property of a material when exposed to heat.

### Fixed-Temperature Detectors

Fixed-temperature detectors are designed to alarm when the temperature of the operating element reaches a specified point. The air temperature at the time of operation is usually higher than the rated temperature due to the thermal inertia of the operating elements. Fixed-temperature heat detectors are available to cover a wide range of operating temperatures ranging from 57 °C (135 °F) and up. Higher temperature detectors are necessary so that detection can be provided in areas that are normally subjected to high ambient (nonfire) temperatures.

Eutectic metals, alloys of bismuth, lead, tin, and cadmium, which melt rapidly at a predetermined temperature, can be used as operating elements for heat detection. The most common such use is the fusible element in an automatic sprinkler head. Fusing of the element allows water to flow in the system, which triggers an alarm by various electrical or mechanical means. A eutectic metal may be used in one of two ways to actuate an electrical alarm circuit. The simplest method is to place the eutectic element in series with a normally closed circuit. Fusing of the metal opens the circuit to trigger an alarm. The second method employs a eutectic metal as a solder to secure a spring under tension. When the element fuses, the spring action is used to close contacts and sound an alarm. Devices using eutectic metals cannot be restored. Either the device or its operating element must be replaced following operation.

Frangible glass bulbs similar to those used for sprinkler heads have been used to actuate alarm circuits. The bulb, which contains a high vapor pressure liquid and a small air bubble, is used as a strut to maintain a normally open switching circuit. When exposed to heat, the liquid expands, compressing the air bubble. When the bubble is completely absorbed, there is a rapid increase in pressure, shattering the bulb and allowing the contacts to close. The desired temperature rating is obtained by controlling the size of the air bubble relative to the amount of liquid in the bulb.

As an alternative to spot-type fixed-temperature detection, various methods of continuous line detection have been developed. One type of line detector uses a pair of steel wires in a normally open circuit. The conductors are insulated from each other by a thermoplastic of known fusing temperature. The wires are under tension and held together by a braided sheath to form a single cable assembly (fig. 1). When the design temperature is reached, the insulation melts, contact is made, and an alarm is generated. Following an alarm, the fused section of the cable must be replaced to restore the system.

A similar alarm device utilizing a semiconductor material and a stainless steel capillary tube has been developed for use where mechanical stability is a factor (fig. 2). The capillary tube contains a coaxial center conductor separated from the tube wall by a temperature-sensitive glass semiconductor material. Under normal conditions, a small current (i.e., below alarm threshold) flows in the circuit. As the temperature rises, the resistance of the semiconductor decreases allowing more current flow and triggering the alarm.



Bimetals are used for the operating elements of several types of fixed-temperature detectors. When a sandwich of two metals having different coefficients of thermal expansion is heated, differential expansion causes bending or flexing towards the metal having the lower expansion rate. This action closes a normally open circuit. The low expansion metal commonly used is Invar, an alloy of 36 percent nickel and 64 percent iron. Several alloys of manganese-copper-nickel, nickel-chromium-iron or stainless steel may be used for the high expansion component of a bimetal assembly.

Bimetal detectors are generally of two types, the bimetal strip and the bimetal snap disc. Some devices use bimetal strips placed directly in the alarm circuit. As the strip is heated it deforms in the direction of its contact point. The width of the gap between the contacts determines the operating temperature. The wider the gap, the higher the operating point. Drawbacks to this type of device are its lack of rapid positive action and its susceptibility to false alarms from vibration or jarring, particularly as the rated temperature is approached, for example, during periods of transient high ambient temperatures that are below the alarm point.

The operating element of a snap-disc device is a bimetal disc formed into a concave shape in its unstressed condition (fig. 3). As the disc is heated, the stresses developed cause it to reverse curvature suddenly and become convex. This provides a rapid positive action, which allows the alarm contacts to close. The disc itself is not usually part of the electrical circuit. Snap-disc devices are not as sensitive to false or intermittent alarms as the bimetal strips described above.

A different application of the thermal expansion properties of metals is found in the rate compensation detectors, which use metals of different thermal expansion rates to compensate for slow changes in temperature while responding with an alarm for rapid rates of temperature rise and at a fixed maximum temperature as well. For a further discussion of this device, see the section on Combination Detectors.

All thermal detectors using bimetal or expanding metal elements have the desirable feature of automatic restoration after operation when the ambient temperature drops below the operating point.

#### Rate-of-Rise Detectors

One effect that a fire has on the surrounding environment is to generate a rapid increase in air temperature in the area above the fire. While fixed-temperature heat detectors must wait until the gas temperature near the ceiling reaches or exceeds the designated operating point before sounding an alarm, the rate-of-rise detector will function when the rate of temperature change exceeds a predetermined value, typically around 8.3 °C (15 °F) per minute. Detectors of the rate-of-rise type are designed to compensate either mechanically or electrically for normal changes in ambient temperature that are expected under nonfire conditions.

The increased pressure of gas when heated in a closed system can be used to generate a mechanical force that will operate alarm contacts in a pneumatic fire detection device. In a completely closed system, actuation will occur strictly from a slow change in ambient temperature, regardless of the rate of

temperature change. The pneumatic detectors in use today provide a small opening to vent the pressure that builds up during slow changes in temperature. The vents are sized so that when the temperature changes rapidly, such as in a fire situation, the pressure change exceeds the venting rate and the system is pressurized. These systems are generally sensitive to rates of temperature rise exceeding 8.3 °C (15 °F) per minute. The pressure is converted to mechanical action by a flexible diaphragm. A generalized schematic of a pneumatic heat detection system is shown in figure 4.

Pneumatic heat detectors are available for both line and spot applications. The line systems consist of metal tubing in a loop configuration attached to the ceiling of the area to be protected. Except where specifically approved, Underwriters' Laboratories requires that lines of tubing be spaced not more than 9.1 m (30 ft) apart and that no single circuit exceed 305 m (1000 ft) in length. Zoning can be achieved by selected siting of lines or by insulating those portions of a circuit that pass through areas from which a signal is not desired.

For spot applications and in small areas where line systems might not be able to generate sufficient pressures to actuate the alarm contacts, heat collecting air chambers or rosettes are often used. These units act like a spot-type detector by providing a large volume of air to be expanded at a single location.

The pneumatic principle is also used to close contacts within spot detectors of the combined rate-of-rise/fixed-temperature type. These devices are discussed in the following section.

#### Combination Detectors

Several devices are available that use more than one operating mechanism and will respond to multiple fire signals with a single unit. The combination detectors may be designed to alarm either from any one of several fire signals or only when all the signals are present at predetermined levels.

Several heat detection devices are available that operate on both the rate-of-rise and fixed-temperature principles. The advantage of units such as these is that the rate-of-rise elements will respond quickly to rapidly developing fires, while the fixed-temperature elements will respond to slowly developing smoldering fires when the design alarm temperature is reached. The most common type uses a vented hemispherical air chamber and a flexible diaphragm for the rate-of-rise function. The fixed-temperature element may be either a bimetal strip (fig. 5) or a leaf spring restrained by a eutectic metal (fig. 6). When the designed operating temperature is reached, either the bimetal strip flexes to the contact point or the eutectic metal fuses, releasing the spring which closes the contacts.

A second device that can be classified as combination rate-of-rise/fixed-temperature is the rate-compensation detector. This detector uses a metal cylinder containing two metal struts. These struts act as the alarm contacts and are under compression in a normally open position (fig. 7). The outer shell is made of a material with a high coefficient of thermal expansion, usually aluminum, while the struts, usually copper, have a lower expansion coefficient. When exposed to a rapid change in temperature, the shell expands

rapidly, relieving the force on the struts and allowing them to close. Under slowly increasing temperature conditions both the shell and struts expand. The contacts remain open until the cylinder, which expands at a greater rate, has elongated sufficiently to allow them to close. This closure occurs at the fixed-temperature rating of the device.

### Thermoelectric Detectors

Various thermoelectric properties of metals have been successfully applied in devices for heat detection. Operation is based either on the generation of a voltage between bimetallic junctions (thermocouples) at different temperatures or variations in rates of resistivity change with temperature.

These spot-type devices, which operate in the voltage-generating mode, use two sets of thermocouples. One set is exposed to changes in the atmospheric temperature and the other is not. During periods of rapid temperature change associated with a fire, the temperature of the exposed set increases faster than the unexposed set and a net potential is generated. The voltage increase associated with this potential is used to operate the alarm circuit.

## SMOKE DETECTION

### Types

Smoke detectors are more costly than heat detectors but provide considerably faster detection times and subsequently higher false alarm rates due to their increased sensitivity. While smoke detectors are very effective for life safety applications, they are also more difficult to locate properly, since air currents, which might affect the direction of smoke flow, must be taken into consideration.

Smoke detectors are classified according to their operating principle and are of two main types: ionization and photoelectric. Smoke detectors operating on the photoelectric principle give somewhat faster response to the products generated by fires of low energy (smoldering) as these fires generally produce large quantities of visible (larger particle) smoke. Smoke detectors using the ionization principle provide somewhat faster response to fires of high energy (open flaming) as these fires produce the smaller smoke particles that are more easily detected by this type of detector.

Smoke detectors should be used to protect areas of high value and areas where life safety and fast response times are desired. Smoke detectors can operate within seconds of fire ignition.

Smoke detectors are also installed in return air ducts of ventilating (HVAC) systems in large buildings to prevent recirculation of smoke through the HVAC system from a fire within the building. Upon detection, the associated control system is designed to automatically shut down the circulating blowers or to change them over to a smoke exhaust mode. Smoke-activated devices are also used to automatically close smoke doors in large buildings in order to limit the spread of smoke in case of fire. This may be done with separate corridor-ceiling mounted smoke detectors connected to

electrically-operated hold-open devices on the doors or smoke detectors that are built into the door closure units themselves.

### Ionization Detectors

Ionization chambers have been used for many years as laboratory instruments for detecting microscopic particles. In 1939 Ernst Meili, a Swiss physicist, developed an ionization chamber device for the detection of combustible gases in mines (ref. 11). The major breakthrough in the field resulted from Meili's invention of a special cold-cathode tube, which would amplify the small signal produced by the high impedance detection circuit sufficiently to trigger an alarm circuit. This reduced the electronics required and resulted in a practical detector. In most models today, the cold-cathode tube has been replaced with solid state circuitry, which further reduces the size and cost.

The basic detection mechanism of an ionization detector consists of an alpha or beta radiation source in a chamber containing positive and negative electrodes. Alpha radiation sources are commonly americium-241 or radium-226, and the strength of the sources generally range from 2000 to 3 000 000 disintegrations per second (0.05 to 80  $\mu\text{Ci}$ ). The alpha radiation in the chamber ionizes the oxygen and nitrogen molecules in the air between the electrodes causing a small current (of the order of  $10^{-11}$  A) to flow when voltage is applied (fig. 8).

When a smoke aerosol enters the chamber, it reduces the mobility of the ions, and therefore the current flow between the electrodes (fig. 9). The resulting change in the current in the electronic circuit is used to trigger an alarm at a predetermined level of smoke in the chamber. The ionization chamber detector reacts to both visible and invisible components of the products of combustion. It responds best to particle sizes between 0.01 and 1.0  $\mu\text{m}$ .

Depending on the placement of the alpha source, two types of chambers, unipolar or bipolar, may be produced. A unipolar chamber is created by using a tightly collimated alpha source placed close to the negative electrode, thus ionizing only a small part of the chamber space (fig. 10). With this configuration, most of the positive ions are collected on the cathode, leaving a predominance of negative ions flowing through the chamber to the anode. The bipolar chamber has the alpha source centrally located so that the entire chamber space is subject to ionization (fig. 11). The unipolar chamber is theoretically a unipolar and bipolar chamber in series (figs. 10 and 12). That is, there is a purely unipolar section and a section which contains ions of both polarities.

A comparison of the relative merits of the two types of chamber design indicates that the unipolar chamber has approximately three times the sensitivity of the bipolar configuration. The reason for the increased sensitivity is believed to be due to the fact that there is less loss of ion carriers by recombination, i.e. neutralization of ions of opposite signs, which occurs in the bipolar chamber. This results in a higher signal-to-noise ratio and a stronger alarm signal to the amplifier circuit.

The alarm signal in an ion chamber detector is generated by a voltage shift at the junction between a reference circuit and the measuring chamber.

The voltage shift results from a current decrease in the measuring chamber when products of combustion are present. The reference circuit may be either electronic or a second ion chamber only partially open to the atmosphere (fig. 13). These circuits are referred to as single chamber and dual chamber, respectively. The dual chamber has an advantage in the reduction of false alarms due to changes in ambient conditions. The reference chamber will tend to compensate for slow changes in temperature, pressure, and humidity.

It should be noted that some ion chamber detector designs are subject to changes in sensitivity with varying velocity of air entering the sampling chamber. Detectors with unipolar chamber designs move slightly away from alarm as velocity increases and are the most stable over wide variations in airflow. Detectors with bipolar chamber designs move toward alarm as velocity increases, and some may shift sufficiently in the more sensitive direction to trigger a false alarm. Care must be taken to choose the appropriate design for the area to be supervised.

Tests have indicated that ion chamber detectors are not suitable for use in applications where high ambient radioactivity levels are to be expected. The effect of radiation is to reduce the sensitivity. Tests also indicate that false alarms can be triggered by the presence of ozone or ammonia.

Ion chamber detectors are available for both industrial and domestic use. Models are produced for both single station and system applications. Power supply requirements vary from 240 and 120 V ac or 6 to 24 V dc for use with fire alarm systems to battery powered units using 9 to 13.5 V dc for residential use.

### Photoelectric Detectors

The presence of suspended smoke particles generated during the combustion process affects the propagation of a light beam passing through the air. This effect can be utilized to detect the presence of a fire in two ways: (1) attenuation of the light intensity over the beam path length, and (2) scattering of the light both in the forward direction and at various angles to the beam path.

The theory of light attenuation by aerosols dispersed in a medium is described by the Lambert-Beer Law. It states that the attenuation of light is an exponential function of the beam path length ( $l$ ), the concentration of particles ( $c$ ), and the extinction coefficient of the particles ( $k$ ). This relationship is expressed as follows (ref. 12):

$$I = I_0 e^{-kcl}$$

where  $I$  is the transmitted intensity at length  $l$  and  $I_0$  is the initial (clear air) intensity of the light source.

Smoke detectors that utilize attenuation consist of a light source, a light beam collimating system, and a photosensitive cell (fig. 14). In most applications, the light source is an incandescent bulb, but lasers and light emitting diodes (LED's) are also used in newer photoelectric aerosol detectors. Light emitting diodes are a reliable long life source of illumination with low current requirements. Pulsed LED's can generate sufficient light intensity for use in detection equipment.

The photosensitive device may be either a photovoltaic or photoresistive cell. The photovoltaic cells are usually selenium or silicon cells, which produce a voltage when exposed to light. These have the advantage that no bias voltage is needed, but, in most cases, the output signal is low and an amplification circuit is required. These units alarm when the photocell output is reduced by attenuation of the light as it passes through the smoke in the atmosphere between the light source and the photocell. Photoresistive cells change resistance as the intensity of the incident light varies. Cadmium sulfide cells are most commonly employed. These cells are often used as one leg of a Wheatstone bridge, and an alarm is triggered when the voltage shift in the bridge circuit reaches a predetermined level related to the light attenuation desired for alarm.

In practice, most light attenuation or projected beam smoke detection systems are used to protect large open areas and are installed with the light source at one end of the area to be protected and the receiver (photocell/relay assembly) at the other end. In some applications, the effective beam path length is increased by the use of mirrors. Projected beam detectors are generally installed close to the ceiling, where the earliest detection is possible and false alarms resulting from inadvertent breaking of the beam are minimized.

Although most systems employ a long path length and separation of the light source and the receiver, there are spot-type detectors which operate by light attenuation. One such unit uses a 0.19-m (7.8-in.) light path with a sealed reference chamber and an open sampling chamber, each containing a photocell. Presence of smoke in the sampling chamber results in a voltage reduction from its selenium photocell, which is measured by a bridge circuit containing the photocell from the reference chamber (fig. 15).

There are several problems associated with projected beam detection. Since these devices are essentially line detectors, smoke must travel from the point of generation into the path of the light beam. This may take time and allow the fire to develop headway before the alarm is sounded. In addition, for large protected areas where long beam path lengths are necessary, considerable smoke must be generated in any small segment of the beam in order for sufficient attenuation to be achieved. Two common ways of increasing the sensitivity of the system are by the use of multiple beams or reflecting mirrors that would pass the beam through the smoke more than once. Finally, continuous exposure to light can damage or accelerate the aging of photocells, resulting in increased maintenance and possible system failure.

Scattering results when light strikes aerosol particles in suspension. Scattered light reaches its maximum intensity at an angle of about  $27^\circ$  from the path of the beam in both the forward and backward directions and the scattered light intensity is at a minimum in a direction perpendicular to the beam path. The intensity of scattered light is also related to particle size and the wavelength of the incident light. This intensity, as described by Rayleigh's theory for particles with diameters less than 0.1 times the wavelength of the incident light, is directly proportional to the square of the particle volume and inversely proportional to the fourth power of the wavelength. The theory of scattering for larger particles, from 0.1 to 4 times the wavelength of the incident light, has been defined by Mie. These theories of light scattering are valid only for isotropic spherical particles and are very complex. However, smoke particles from a fire consist of a nonhomogeneous

mixture of particles, which are often neither spherical nor isotropic, and scattering intensities must be determined empirically for each aerosol mixture.

Smoke detectors utilizing the scattering principle operate on the forward scattering of light which occurs when smoke particles enter a chamber or labyrinth. The presence of smoke will increase the forward scattering of light from 10 to 12 times, but the intensity of the scattered light will decrease as the angle between the beam path and the photocell increases beyond 27°. The photocells used in these detectors may be either photovoltaic, or photoresistive. Typical component configurations are shown in figure 16. These units are of the spot type and may be used as single station devices with self-contained power supply and alarm or as part of an integrated system with remote power supply, alarm, and zone-indicating hardware.

## FLAME DETECTION

### Types

Flame detectors optically sense either the ultraviolet (UV) or infrared (IR) radiation given off by flames or glowing embers. Flame detectors have the highest false alarm rate and the fastest detection times of any type of fire detector. Detection times for flame detectors are generally measured in milliseconds from fire ignition.

Flame detectors are generally only used in high hazard areas such as fuel loading platforms, industrial process areas, hyperbaric chambers, high ceiling areas, and any other areas with atmospheres in which explosions or very rapid fires may occur. Flame detectors are "line of sight" devices as they must be able to "see" the fire, and they are subject to being blocked by objects placed in front of them. However, the infrared type of flame detector has some capability for detecting radiation reflected from walls. In general, the use of flame detectors is restricted to "No Smoking" areas or anywhere where highly flammable materials are stored or used.

### Infrared Detectors

Infrared detectors basically consist of a filter and lens system to screen out unwanted wavelengths and focus the incoming energy on a photovoltaic or photoresistive cell sensitive to the infrared. Infrared radiation can be detected by any one of several photocells such as silicon, lead sulfide, indium arsenide, and lead selenide. The most commonly used are silicon and lead sulfide. These detectors can respond to either the total IR component of the flame alone or in combination with flame flicker in the frequency range of 5 to 30 Hz.

Interference from solar radiation in the infrared region can be a major problem in the use of infrared detectors receiving total IR radiation since the solar background intensity can be considerably larger than that of a flame signal from a small fire. This problem can be partially resolved by choosing filters which exclude all IR except in the 2.5 to 2.8  $\mu\text{m}$  and/or 4.2 to 4.5  $\mu\text{m}$  ranges. These represent absorption peaks for solar radiation due to the presence of CO<sub>2</sub> and water in the atmosphere. In cases where the detectors are to be used in locations shielded from the sun, such as in vaults, this

filtering is not necessary. Another approach to the solar interference problem is to employ two detection circuits. One circuit is sensitive to solar radiation in the 0.6 to 1.0  $\mu\text{m}$  range and is used to indicate the presence of sunlight. The second circuit is filtered to respond to wavelengths between 2 and 5  $\mu\text{m}$ . A signal from the solar sensor circuit can be used to block the output from the fire sensing cell, giving the detection unit the ability to discriminate against false alarms from solar sources. This is often referred to as a "two color" system. For most applications, flame flicker sensor circuits are preferred since the flicker or modulation characteristic of flaming combustion is not a component of either solar or man-made interference sources. This results in an improved signal-to-noise ratio. These detectors use frequency sensitive amplifiers whose inputs are tuned to respond to an alternating current signal in the flame flicker range (5 to 30 Hz).

Flame detectors are designed for volume supervision and may use either a fixed or scanning mode. The fixed units continuously observe a conical volume limited by the viewing angle of the lens system and the alarm threshold. The viewing angles range from 15 to 170° for typical commercial units. One scanning device has a 120-m (400 ft) range and uses a mirror rotating at 6 rpm through 360° horizontally with a 100° viewing angle. The mirror stops when a signal is received. To screen out transients, the unit alarms only if the signal persists for 15 sec.

There are also detectors of this type designed to respond to passing sparks or flame fronts in piping such as in textile mills. The detector looks for glowing lint fibers in air ducting, which might cause fires in the downstream filters. The detector turns on a water spray, which extinguishes the glowing fiber before it reaches the filter. Of course, these detectors would not contain the flicker circuit.

#### Ultraviolet Detectors

The ultraviolet component of flame radiation is also used for fire detection. The sensing element may be a solid state device such as silicon carbide or aluminum nitride, or a gas-filled tube in which the gas is ionized by UV radiation and becomes conductive, thus sounding the alarm. The operating wavelength range of UV detectors is in the 0.17 to 0.30  $\mu\text{m}$  region and in that region they are essentially insensitive to both sunlight and artificial light. The UV detectors are also volume detectors and have viewing angles from 90° or less to 180°.

The combination of UV-IR sensing has been applied to applications in aircraft and hyperbaric chamber fire protection. These complex devices alarm when there is a predetermined deviation from the prescribed ambient UV-IR discrimination level in conjunction with a signal from a continuous wire overheat detector, the analysis being performed by an onboard minicomputer.

#### SUBMICROMETER PARTICLE COUNTING DETECTORS

During the earliest stages of thermal decomposition, in the pyrolysis or precombustion stage, large numbers of submicrometer size particles are produced. These particles fall largely in the size range between 0.005 and 0.02  $\mu\text{m}$ . Although ambient conditions normally find such particles in



concentrations from several thousand per cubic centimeter in a rural area to several hundred thousand per cubic centimeter in an industrial area, the presence of an incipient fire can raise the submicrometer particle concentration sufficiently above the background levels to be used as a fire signal.

Condensation nuclei are liquid or solid submicrometer (0.001 to 0.1  $\mu\text{m}$ ) particles which can act as the nucleus for the formation of a water droplet. By use of an appropriate technique, submicrometer particles can be made to act as condensation nuclei on a one particle-one droplet basis, and the concentration of particles is measured by photoelectric methods. A mechanism for performing this function is shown schematically in figure 17. An air sample containing submicrometer particles is drawn through a humidifier where it is brought to 100 percent relative humidity. The sample then passes to an expansion chamber where the pressure is reduced with a vacuum pump. This causes condensation of water on the particles. The droplets quickly reach a size where they can scatter light. The dark field optical system in the chamber will allow light to reach the photomultiplier tube only when the water droplets are present to scatter light. The output voltage from the photomultiplier tube is directly proportional to the number of droplets (i.e., the number of condensation nuclei) present.

The system uses a mechanical valve and switching arrangement to allow sampling from up to 4 detection zones with as many as 10 sampling heads per zone. Each zone is sampled once per second for 15 sec. All four zones are sampled each minute. The system is nominally set to alarm at concentrations exceeding  $8 \times 10^{11}$  particles per cubic meter, although it is possible to select different thresholds for each zone depending on the background noise and the sensitivity required. It is also possible to have the sensitivity vary for conditions differing with time of day. The system design is such that, with the maximum sample travel distance from the most remote sampling head, fire will be detected within 2 min of the time the products of combustion first reach a sampling head.

## SELECTION OF DETECTORS

When laying out a fire detection system, the design engineer must keep in mind the operating characteristics of the individual detector type as they relate to the area protected. Such factors as type and quantity of fuel, possible ignition sources, ranges of ambient conditions, and value of the protected property are critical in the proper design of the system. Intelligent application of detection devices using such factors will result in the maximization of system performance. Table I is a summary of fire detector application criteria as they are discussed in this section.

Heat detectors have the lowest cost and false alarm rate but are the slowest in response. Since heat tends to dissipate fairly rapidly (for small fires), heat detectors are best applied in confined spaces, or directly over hazards where flaming fires could be expected. Heat detectors are generally installed on a grid pattern at either their recommended spacing schedule or at reduced spacing where beams or joists may impede the spread of the hot gas layer, for faster response. The operating temperature of a heat detector is usually selected at least 14  $^{\circ}\text{C}$  (25  $^{\circ}\text{F}$ ) above the maximum expected ambient temperature in the area protected. Pneumatic heat detection systems have a

device known as a "blower heater compensator," which is used to prevent false alarms due to the sharp initial heat from ceiling-mounted unit heaters.

Smoke detectors are higher in cost than heat detectors but are faster in responding to fires. Due to the greater sensitivity of these detectors, false alarms can be more frequent, especially if the detectors are not properly located. Smoke detectors do not have a specific space rating except for a 9-m (30-ft) maximum guide derived from the UL full-scale approval tests which they must pass. Grid type installation layouts are usually not used, since smoke travel is greatly affected by air currents in the protected area. Thus, smoke detectors are usually placed by engineering judgment based on prevailing conditions.

Since smoke does not dissipate as rapidly as heat, smoke detectors are better suited to the protection of large, open spaces than heat detectors. Smoke detectors are more subject to damage by corrosion, dust, and environmental extremes than the simpler heat detectors because smoke detectors contain electronic circuitry. They also consume power, so the number of smoke detectors which can be connected to a control unit may be limited by the power supply capability.

Photoelectric smoke detectors are particularly suitable where smoldering fires or fires involving low temperatures pyrolysis of PVC wire insulation may be expected. Ionization smoke detectors are particularly suitable where flaming fires involving any other materials would be the case. The particle counter detector responds to all particle sizes equally, so it may be used without regard to the type of fire expected. These systems, however, are fairly expensive and complex to install and maintain. The design and layout of the sampling tubes is critical and must be done by someone familiar with the equipment.

Flame detectors are extremely fast responding but will alarm to any source of radiation in their sensitivity range, so false alarm rates are high if they are improperly applied. Flame detectors are usually used in hyperbaric chambers and flammable material storage areas where no flames of any sort are allowable.

Flame detectors are "line of sight" devices, so care must be taken to ensure that they can "see" the entire protected area and that they will not be accidentally blocked by stacked material or equipment. Their sensitivity is a function of flame size and distance from the detector, and some detectors can be adjusted to ignore a small flame at floor level. Their cost is relatively high, but they are well suited for areas where explosive or flammable vapors or dusts are encountered as they are usually available in "explosion proof" housings.

## FIRE MODELS

Over the past decade, considerable progress has been made in understanding the processes of fire. While there is still much to be learned, the current understanding is such that fairly accurate predictions of the impact of a fire in a compartment can be made using computer simulation techniques. These fire models can predict the production and distribution of energy and mass within

a series of interconnected compartments over time, and the effect of exposure to these combustion products on occupants, equipment, and the structure itself. Thus, one possible use of these models is to evaluate the response of detection devices required to provide the desired level of safety to occupants or critical equipment without being so sensitive that excessive false alarms are experienced.

The concept of designing a detection system such that it responds prior to the fire reaching a specified energy release rate was recently introduced into the National Fire Protection Association Standard on Detection Devices (72E). Here, a model was used to develop a set of curves for detector activation as a function of installed spacing for various ceiling heights, fire growth rates, and detector characteristics (e.g., thermal time constant). The designer decides on a fire size (energy output) at activation for the anticipated fire within the protected space and determines the detector spacing necessary for the actual compartment ceiling height.

TABLE I. - SUMMARY OF DETECTOR APPLICATION CONSIDERATIONS

Detector type	Response speed	False alarm rate	Cost	Application
Heat	Slow	Low	Low	Confined spaces
Smoke	Fast	Medium	Medium	Open or confined spaces
Flame	Very fast	High	High	Flammable material storage
Particle	Fast	Medium	High	Open spaces - high value

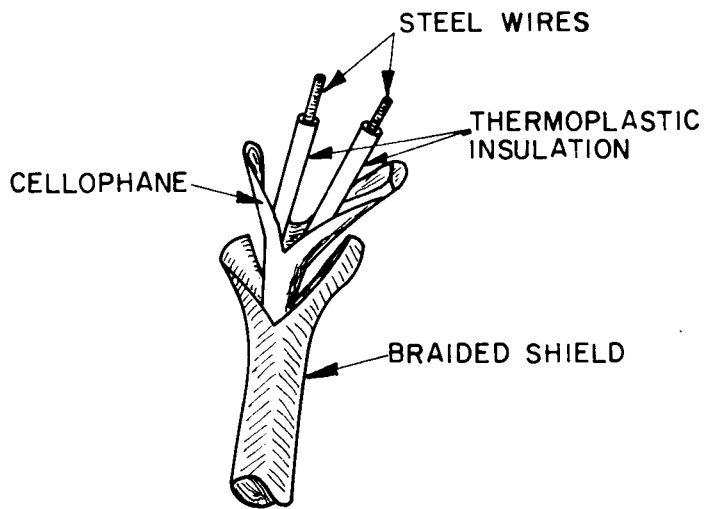

Figure 1. - Line-type fire detection cable using insulated parallel wires.

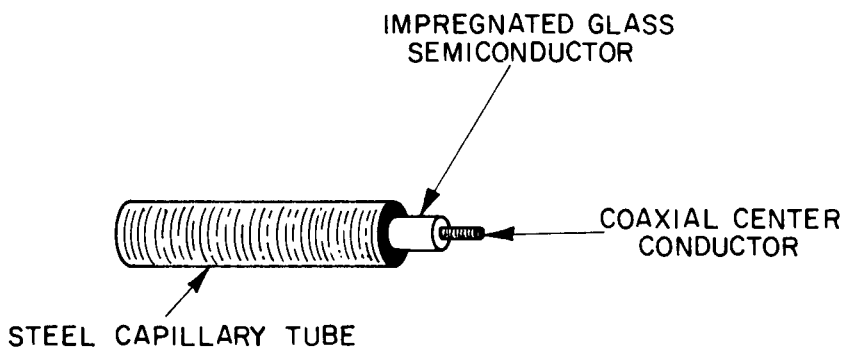

Figure 2. - Line-type fire detection cable using a glass semiconductor.

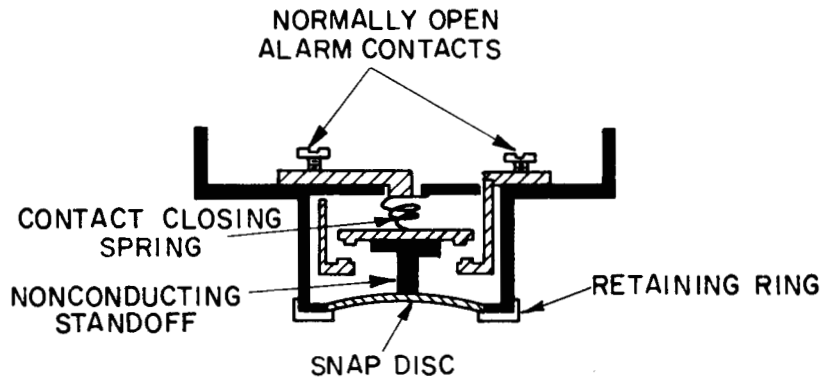

Figure 3. - Bimetal snap-disc heat detector.

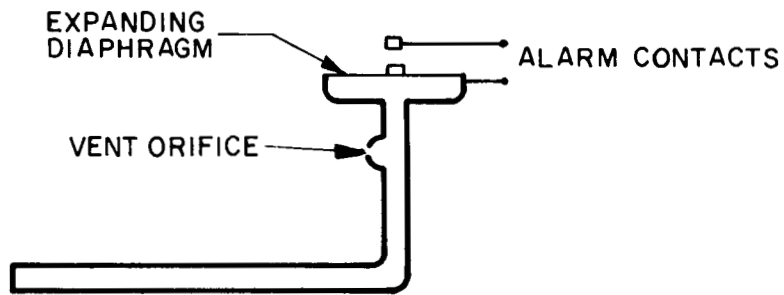

Figure 4. - Pneumatic-type heat detector.

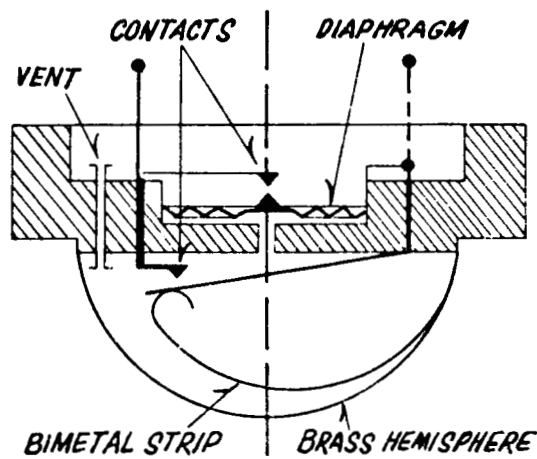

Figure 5. - Rate of rise fixed-temperature detector using a bimetal element.

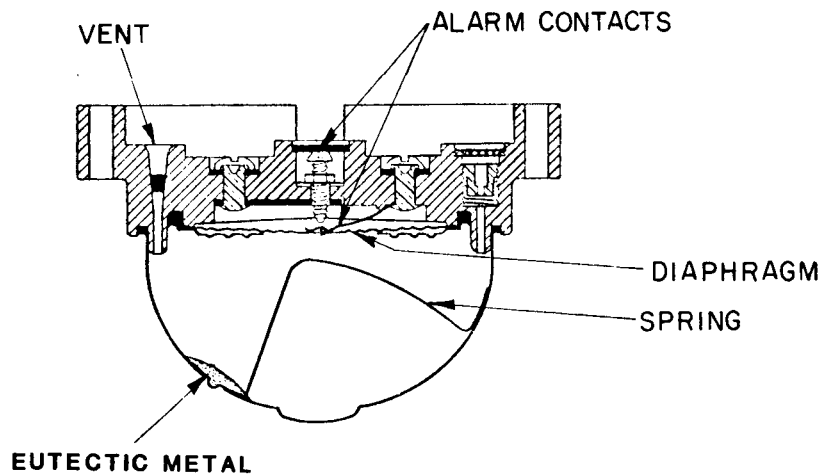

Figure 6. - Rate of rise fixed-temperature detector using a eutectic metal.

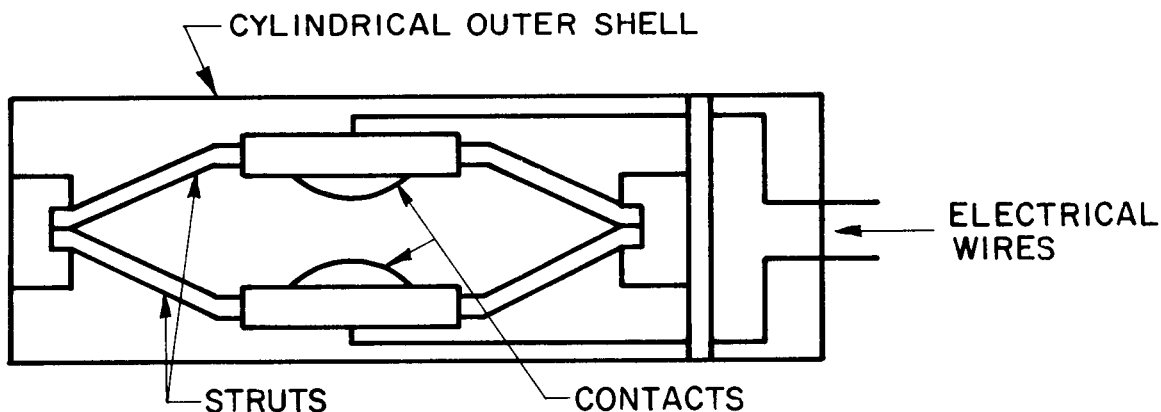

Figure 7. - Rate-compensation detector.

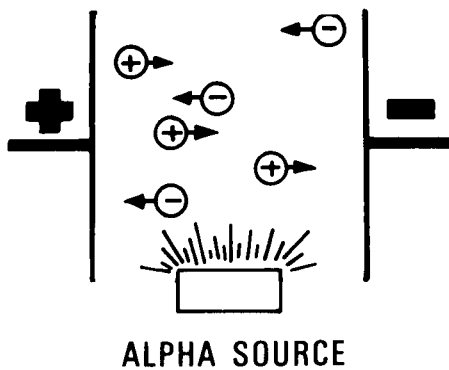

Figure 8. - Ionization of chamber air space.

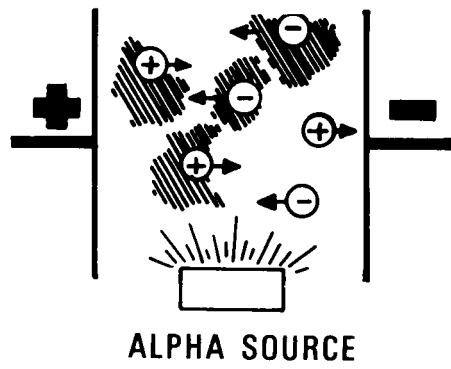

Figure 9. - Effect of aerosol in ionized chamber.

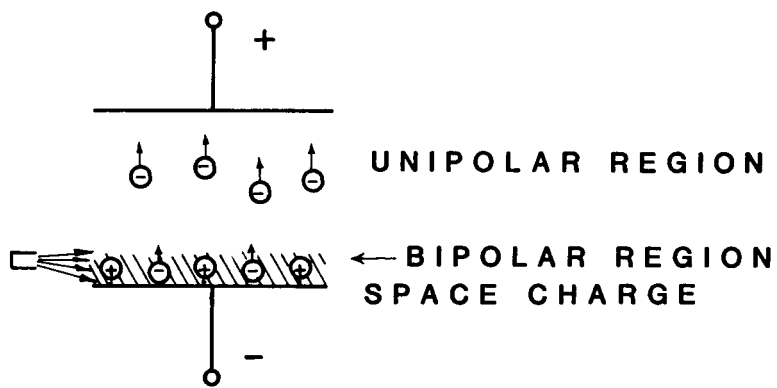

Figure 10. - Unipolar ion chamber.

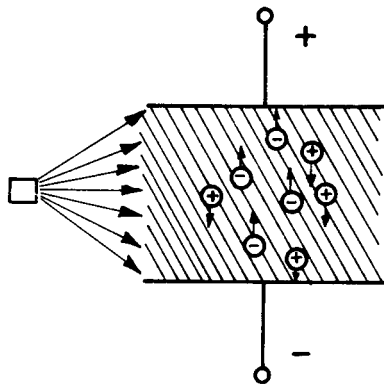

Figure 11. - Bipolar ion chamber.

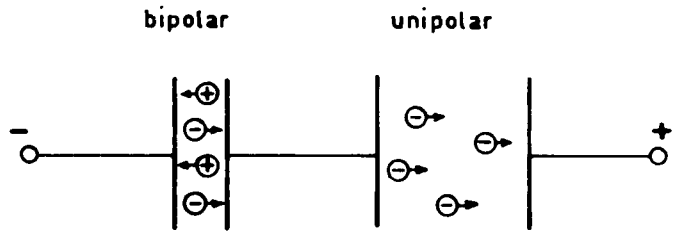

Figure 12. - Unipolar ion chamber consisting of theoretical unipolar and bipolar ion chambers in series.

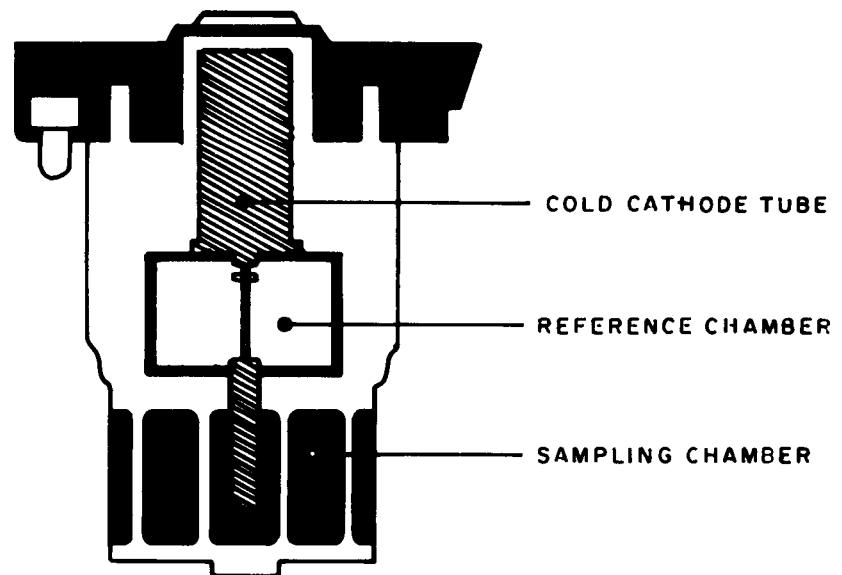

Figure 13. - Configuration of a dual ion chamber detector.

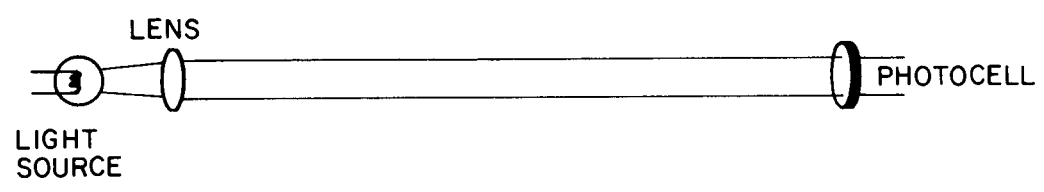

Figure 14. - Beam-type light attenuation smoke detector.



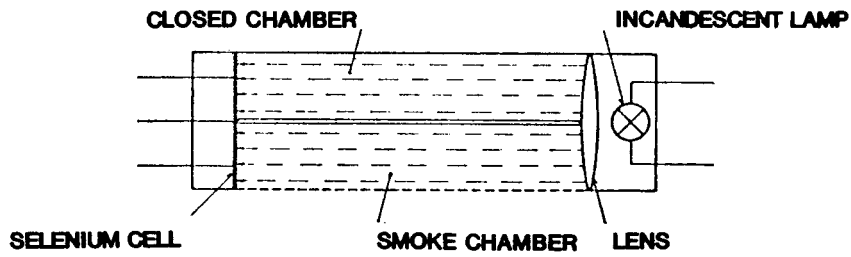

Figure 15. - Spot-type light attenuation smoke detector.

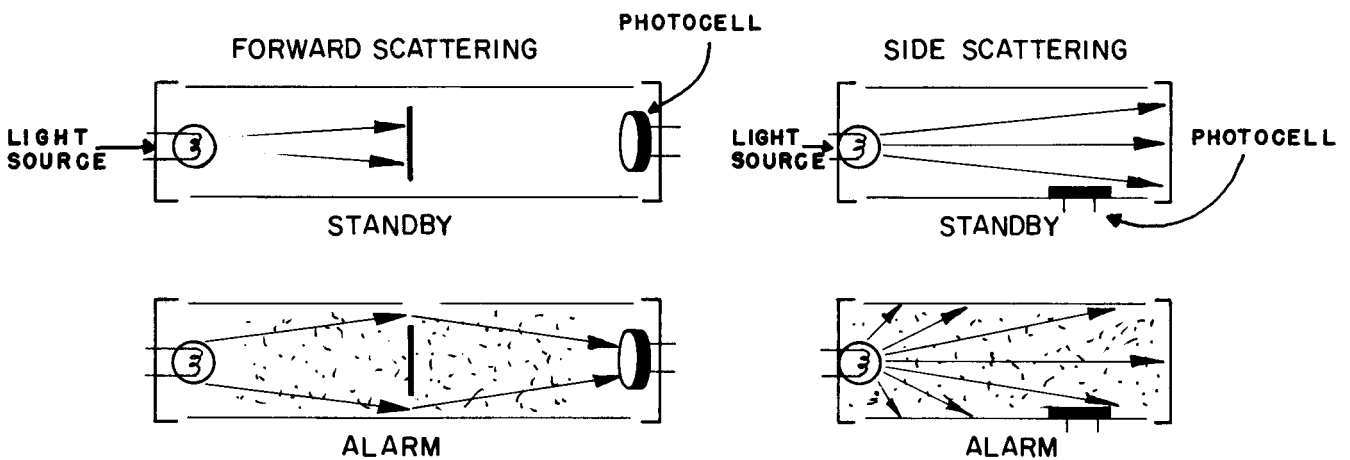

Figure 16. - Light-scattering smoke detectors.

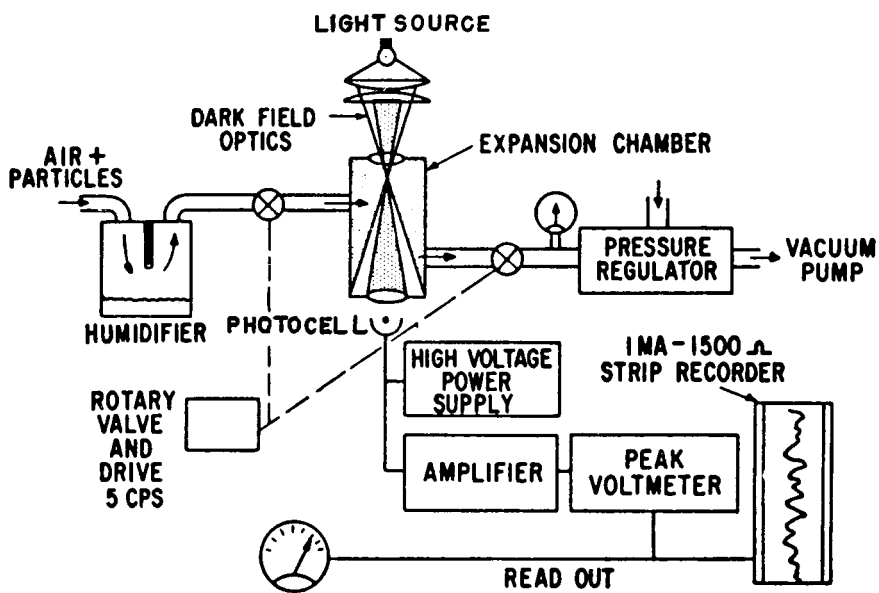

Figure 17. - Schematic of condensation nuclei particle detector.

## FIRE-RELATED STANDARDS AND TESTING

Vytenis Babrauskas  
Center for Fire Research  
National Bureau of Standards

## INTRODUCTION

The state of the art in the flammability testing has been changing rapidly. In this paper, the progress in developing general test methods for solid materials and products exposed to an external fire will be reviewed, the special requirements pertinent to environments of concern to NASA will be examined, and some indications for possible directions for future test method developments will be given.

## FLAMMABILITY ENGINEERING TESTS

Flammability tests developed in the 1950's and the 1960's tended to be of a very ad hoc nature. Typically, some problem materials were identified, and a program was launched to eliminate their use by finding some test, often of a Bunsen burner type, which would fail some of them, while allowing more desirable materials to pass. In those times, this was a reasonable course of action, since the underlying combustion physics and chemistry were largely unknown. Most of the existing tests on the books are still of this philosophy. The latest compilation, for example, by the American Society for Testing and Materials (ASIM) lists 70 distinct flammability test methods, most of them of this ad hoc nature (ref. 13). Recently, however, the philosophy of designing proper tests has changed considerably. It is taken that a useful test is a full scale fire test, where the test article is subject to a worst design case scenario. The results can usually be interpreted fairly directly. Standardization of such a test is not necessarily desirable, since, by definition, it must incorporate project-specific features. Nonetheless, ASIM has seen fit to establish both a guide (ref. 14) and a standard (ref. 15) for room fire tests.

In most instances of fire safety engineering, full scale testing is not appropriate, and suitable bench scale tests must be sought. It can now be seen that bench-scale tests can be used to serve at least three different purposes:

- (1) Prediction of expected full-scale behavior
- (2) Quality control assurance in manufacturing
- (3) Guidance in product development

The advances of the last 15 years or so in fire physics and chemistry have enabled a systematic approach to be taken for producing tests suitable to meet objective (1). The steps required are as follows:

- (1) Identify the governing physical and chemical principles of the phenomenon to be measured.

(2) Design a candidate bench-scale test using these principles.

(3) Identify the range, best to worst, of relevant full-scale product behaviors and assemble specimens having those expected traits.

(4) Assemble a data base by testing this range of specimens at full scale and gather data using instruments appropriately designed to measure the governing physical and chemical phenomena.

(5) Conduct bench-scale tests, varying empirically those features of fire behavior that cannot be assigned known constant values.

(6) Attempt to correlate the bench-scale results against the full-scale data base.

(7) Select those bench-scale test protocol features that lead to the best correlation with the full-scale data.

Examples illustrating the details of such a procedure have been published for determining the rates of heat release of upholstered furniture (refs. 16 and 17) and both time to flashover (ref. 16) and rate of heat release (ref. 18) for combustible wall lining materials.

Objective (2), tests for quality control (QC), traditionally constituted a very large family of tests. Here the requirements are that the test must be highly sensitive to small variations in the specimen's physical or chemical properties, that it be well-repeatable, and that it be simple and inexpensive to conduct. The stringent rules of validity that are required of a test for objective (1) are not required. A much looser requirement for validity here is merely that most production-line changes, which can possibly occur in manufacturing to affect the flammability of the specimen, should be reflected in a statistically significant deviation in the test's results. The ASIM standards contain a very large number of examples of these types of tests. Because of its application to the aerospace industry (e.g., the European Space Agency adopted it for qualifying Group I materials (ref. 19)), one example, the Limiting Oxygen Index (LOI) Test (ref. 20), is discussed here.

The LOI test involves the candle-like burning of a rod of plastic material. The apparatus is supplied with an adjustable oxygen/nitrogen flow mixture; the test requires that the minimum concentration of oxygen be found for which the specimen will continue burning downward without flame extinction. Since the results are quoted as an oxygen concentration, the results have widely been interpreted to suggest that a material will not burn in a given atmosphere if its LOI is greater than the oxygen concentration in that atmosphere. Such, of course, is not the case at all. A number of theoretical analyses of the method have been made (refs. 21 to 23). These show that the LOI value, far from reflecting a general property of the material, simply determines the oxygen concentration for which laminar, downward, against-the-wind flame spread ceases in the absence of external heating. The test, in fact, has nothing to do with burning rates at all, but is a flame spread test of a very specific geometry, with data unlikely to be applicable to differing geometries. It has become understood within the fire protection engineering community that the test should not be used to predict actual fire hazard conditions, but it may be a satisfactory quality control test, due to its high sensitivity.

Tests for objective (3), guidance in product development, do not, in principle, need to be standardized, since they are to be used only internally within an organization. In practice, however, industry tends to use published ASIM and other standard tests. The requirements for a good development test are somewhat different than those for a QC test. A good development test must not show crossovers in ranking of materials or products, when compared to full-scale behavior. Its sensitivity is of less concern, however, since minute performance differences would probably not make it worthwhile to redesign a system.

There have not been any comprehensive studies to determine which existing flammability tests are suitable for QC or product development purposes. This type of guidance is usually developed within a given industry on the basis of experience. It must be emphasized, however, that it is never prudent to use a test method as a bench-scale means of assessing the full-scale hazard solely on the basis of its good history of performance as a QC or development test.

#### MODERN CONCEPTS OF TEST METHOD DEVELOPMENT

The understanding of fire development in compartments has been advancing substantially in the last decade, to the point now that there are general purpose computer codes for predicting fire development (e.g., refs. 24 and 25). These codes have been based on an elucidation of the physics of the fire process (ref. 26). The process has three major components that need to be evaluated:

- (1) Ignition
- (2) Flame spread
- (3) Burning and product generation rates

#### Ignition

Ignition here will be assumed to be from an external source of heat or fire. In some design cases, a unique ignition source will be seen to exist. In many other cases, the substance can be ignited from several different external events. It is important to realize that there are theories available that can be used to explain an ignition that comprises a uniform heating of a planar face (e.g., ref. 27). The modeling of ignition from a concentrated, point source is difficult and has not been solved (ref. 28). A Bunsen burner represents a concentrated, nonuniform source; thus data obtained from Bunsen burner tests are not readily usable in modern fire protection engineering designs. As an additional, practical consideration, some materials, which shrink or melt upon heating, can often pass a Bunsen burner test by retreating from the fire, yet they can show serious ignition propensities in actual fire experience.

In addition to the geometric complexity, a specification has to be made whether a primarily radiant or a primarily convective heat source is to be utilized. Hermance (ref. 29) has urged that radiative sources be selected due to the consequent "ability to select the heat flux applied...independently of all other environmental parameters: namely, pressure, initial temperature, and chemical composition of the gas phase." In most cases, also, a well-calibrated radiant source is easier to devise than a convective one, and results are easier to analyze.

For such reasons, the International Organization for Standardization (ISO) adopted a radiant exposure method as its ignitibility test (ref. 30). ASTM lists a number of Bunsen burner type tests, but no uniform-flux ignitibility methods, per se. There is one ASTM method, E906 (ref. 31), which can be used to measure radiant ignitibility; unfortunately the heating fluxes are not well controlled there. There is also a new proposed ASTM method, P-190 (ref. 32), which is primarily a heat release rate method, but which uses a cone heater similar to the ISO method, producing a highly uniform flux distribution over the specimen surface. Recent work (ref. 33) has shown that this method leads to useful, high-quality ignition data, although the ultimate goal of complete apparatus independence of results may never be achieved with real instruments.

### Flame Spread

Solid materials may be ignited at a point, or they may be ignited over a large exposed area; nonetheless, in most fires there is a period where material not yet involved in fire gets progressively involved by flame spread. Thus, it is important to be able to characterize this process. Flame spread has traditionally been measured in the ASTM E84 tunnel (ref. 34). The E84 tunnel is a large-scale instrument; many other ASTM tests and also tests such as the Federal Aviation Administration test FAR 25.853 (ref. 35) are small Bunsen burner tests where the spread of flame is observed. Results from these types of tests are given as ratings on arbitrary scales and cannot be analyzed within the current day modeling capabilities. Lacking this modeling, such data cannot be reinterpreted in the context of a new design geometry.

Newer tests for flame spread are being developed. An example is the International Maritime Organization (IMO) flame-spread test (fig. 1, ref. 36), the behavior of which has been analyzed according to theory (ref. 37). It should be noted, however, that the full incorporation of appropriate flame-spread features into fire models is difficult, although attempts are being made for walls and for upholstered furniture items (ref. 38).

### Burning and Product Generation Rates

The third combustion behavior that must be considered is the burning rate. In older literature this is sometimes confused with what is nowadays described as flame spread rate. Burning rate is the mass loss rate of a specimen when it is fully ignited, with flame spread having covered its entire face. The units are typically expressed as  $\text{kg/m}^2 \text{ s}$ . Product generation rates include a number of related properties, which are distinguished by being proportional to the specimen mass loss rate. Heat release rate (kW) can be viewed as the product of the mass loss rate, times the instantaneous effective heat of combustion (kJ/kg), although it is not desirable to measure it in that manner. Sometimes, also, the term burning rate is used to mean heat, instead of mass-loss rate. Besides heat, the combustion products generated include various gases of interest for toxicity determinations, and also soot and smoke.

The earliest bench-scale instrument for rate of heat release measurement was the ASTM E906, developed in the late 1960's. This instrument is based on a direct measurement of sensible enthalpy and is subject to substantial errors, since adiabatic conditions are not maintained. It also lacks means of measuring the specimen mass. A major breakthrough occurred in the 1970's, when the principle of oxygen consumption (ref. 39) was developed. This principle allows

rate of heat release to be determined indirectly by monitoring oxygen concentrations and flows and has provided a much more reliable technique for use in both full-scale and bench-scale fire testing. For bench-scale testing, this principle has been incorporated into the Cone Calorimeter (ref. 40). The Cone Calorimeter (fig. 2), in addition to being a proposed ASTM test method (ref. 32), also has been selected as the apparatus for a proposed ISO rate of heat release standard.

Over the last two decades, smoke has been most commonly measured by using the NBS Smoke Chamber method (ref. 41). This has been considered to be the best standard on the books, but its limitations--limited flux range, no horizontal orientation, no mass monitoring during the test, and the inability to properly test heavier samples--have shown a need for a newer technique. Such a technique has been developed, in the form of a smoke extinction beam for the Cone Calorimeter (fig. 3, ref. 40). This new technique eliminates these Smoke Chamber shortcomings. The fraction of specimen mass converted to soot mass is a quantity that is related, but not redundant, to the smoke extinction measurement. Thus, for research purposes, the Cone Calorimeter is also equipped with a gravimetric soot measuring system.

Progress is being made at a rapid pace in characterizing the fire toxicity of materials by the use of an appropriately specified set of gas measurements (ref. 42). For obtaining the relevant combustion gas data, the efforts at NBS are focused on using the Cone Calorimeter. This technique is still under development, however, so recommended procedures are not yet finalized.

## THE EFFECTS OF VARIABLES OF SPECIAL INTEREST TO NASA

### Oxygen Concentration

Ignition of solids from radiant heating may be understood most readily as occurring at a time when there is a critical rate of pyrolysis products leaving the surface (ref. 43). This rate is typically seen to be about 1 to  $4 \times 10^{-3}$  kg/m<sup>2</sup>-s in ignitions under normal oxygen conditions and is presumed to correspond to the lower flammable limit being attained for the mixture above the surface of the material. It is reasonable to suppose that varying oxygen concentrations would change the minimum pyrolysate generation condition by reflecting the new fuel vapor concentration required at the new oxygen value.

Experimental work in this area has been largely confined to studies of solid rocket propellants. A theory by McAlevy et al. (ref. 44) suggests that the ignition time  $t_{ign}$  should depend on the oxygen mass fraction  $m_{ox}$  to the minus two-thirds power; however his experimental results show that the dependence is of the order of the minus 1.2 to 1.5 power of the oxygen mass fraction.

Kumar and Hermance (ref. 45) also conducted a theoretical study of propellant ignition. Evaluated for various material properties, their results typically show that ignition time depends on oxygen mass fraction to the minus 1 to 2 power for mass fractions greater than 0.20. For lower oxygen mass fractions, ignition time is independent of oxygen mass fraction.

The solid propellant studies, however, characterized heterogeneous systems, where an oxidizer is already mixed in with the fuel. For accidental

fires, the condensed phase will most likely be pure fuel, with no oxidizer admixture. A theoretical analysis of this case by Kashiwagi (ref. 46) showed that for oxygen mass fractions below 0.20, there is a substantial variation of ignition times, but that the actual relationship is strongly dependent on the exact ignition criterion chosen. For higher oxygen mass fractions, however, ignition time was seen to be only very slightly dependent on oxygen fraction, dropping about 10 percent as the mass fraction goes from 0.23 to 1.00.

Flame spread over solid combustibles can take place in several different domains of behavior, the details of which will not be reviewed here. The effects of oxygen concentration, however, have been of concern for quite some time. In an early review (ref. 47), Magee and McAlevy found that for several geometrical and flow arrangements, the flame spread velocity  $V$  was related to the oxygen mole fraction  $Y_{Ox}$  in a power law relationship, with  $V$  of the order of  $Y_{Ox}$  squared. In a more recent examination of this dependency, Fernandez-Pello and Hirano (ref. 48) found that it holds only for large  $Y_{Ox}$  values. For lower oxygen concentrations, the dependence of the flame spread rate on oxygen mass fraction becomes progressively greater, approaching an infinite-slope asymptote at the  $Y_{Ox}$  value at which extinction occurs. In an experimental study of flame spread over paper specimens, Frey and T'ien (ref. 49) found a dependency, in their case, to the first power of  $Y_{Ox}$  at high  $Y_{Ox}$  values, and a similarly increasing power-law dependency at low oxygen values. Altenkirch has suggested (ref. 50) that oxygen fraction is among the variables which may be successfully correlated by the use of the Damkohler number.

The effects of oxygen level on the mass loss rate  $\dot{m}''$  have been studied in detail by Tewarson (refs. 51 and 52) and Santo (ref. 53). For some materials, they found a direct, linear relationship between  $Y_{Ox}$  and the burning rate. This relationship remains linear down to the lowest  $Y_{Ox}$  value at which combustion is sustained, but the relationship has an offset, that is,

$$\dot{m}'' = aY_{Ox} - b$$

For other materials, including ones showing charring, however, this linear relationship leveled off at higher  $Y_{Ox}$  values.

#### Total Pressure

Similarly as for oxygen effects, the total pressure is expected to affect the ignitibility of a material indirectly by its effect on the lower flammable limit. For many materials, over a fairly wide range of pressures, the lower flammable limit is not significantly affected by total pressure (ref. 54). The early propellant studies of McAlevy et al. (ref. 44) showed a theoretical dependence of ignition time to total pressure  $P_{tot}$  to the minus 1.44 power, while corresponding experimental measurements gave a dependence to the minus 1.77 power.

Very similar results are also reported by Kumar and Hermance (ref. 45). The work of Beyer and Fishman (ref. 55) suggests that the pressure dependence becomes small at low heat fluxes (such as might be expected from an accidental fire), provided the value of  $P_{tot}$  is not also low.

In a more comprehensive study, Shannon (ref. 56) obtained detailed ignition time plots for a number of propellants, covering a wide range of pressures and heat fluxes. The effects of pressure were not well represented as a power law. Instead, for  $P_{tot}$  greater than about 200 kPa (2 atm), there was negligible effect on  $t_{ign}$ . For  $P_{tot}$  less than 2 atm, however, the negative exponent was increasingly greater for lower values of  $P_{tot}$ . The experiments of Kashiwagi et al. on both pure fuels and on propellants (ref. 57) indicate a behavior at very large values of  $P_{tot}$  (>20 atm) where, instead of becoming independent of  $P_{tot}$ , the ignition times vary inversely according to total pressure. Ohlemiller and Summerfield (ref. 58), in a similar study, also show a continued dependence of  $t_{ign}$  on  $P_{tot}$ , even at high  $P_{tot}$  values.

The work of both Kashiwagi (ref. 57) and Ohlemiller (ref. 58) suggests that a combined correlation of the effects of oxygen fraction and the total pressure should not be sought in the use of  $O_2$  partial pressure as a correlating variable, unless only the regime of large  $m_{ox}$  and  $P_{tot}$  values is considered and only approximate results are sought.

Magee and McAlevy (ref. 47) found that for thick fuels the flame spread velocity was proportional to slightly higher than the 1/2 power of the total pressure. For thin fuels, however, the pressure effect was very tiny, being about to the 0.1 power. Frey and T'ien, again, studied the variables over a wider range (ref. 49) and found a 0.1 power dependence only for thin fuels at high (in comparison to the limiting pressure at extinction) pressures and spreading vertically down. For horizontal spread the exponent was higher, but was not unique, there being a strong coupling between oxygen fraction and total pressure effects. In both cases, similarly as for the oxygen fraction effect, the dependence on the total pressure became much greater as the pressure was lowered towards the extinction value. Fernandez-Pello and Hirano (ref. 48) found that over a limited range extinction could be represented by a constant value of  $P_{tot} \times Y_{ox}$ , that is, a constant partial pressure of oxygen. Outside of this limited range, however, such a simplification did not hold.

Test instruments for measuring burning rates have not typically been built to allow pressure to be varied. A pressure modeling program conducted at Factory Mutual Research a few years ago (ref. 59) produced results showing that over a certain range of test variables, a dependence of the mass loss rate was according to the two-thirds power of total pressure. This has not been applied in practical materials testing.

### Gravity

Limited experiments have suggested that the ignitibility of a material is not significantly affected by a lowered gravity or by microgravity conditions (ref. 60). This is in agreement with the findings of Strehlow and Reuss (ref. 61), who concluded that gravity had but a minor effect on the lower limit of flammability.

Experiments by Kimzey (ref. 60), Schreihans (ref. 62), and Altenkirch (refs. 50 and 63) suggest that as far as flame spread is concerned, for gravitational values much greater than that on earth, there is negligible effect of gravity. For gravity levels equal to earth's gravity, there is some disagreement whether the dependence is significant or not (ref. 63). At microgravity



levels, however, it is evident that flame spread rates may be reduced by an order of magnitude or more (ref. 60).

Some very early experiments (ref. 64) indicated that, once ignited, a material is likely to burn even through periods of weightlessness. Hall's study suggested that burning was in some sense accelerated during weightlessness (ref. 64). In general, extensive studies have not been made of the effects of gravity on burning rates. For small items, where convective effects dominate, it would be expected that the burning rate would follow Spalding's B-number theory (ref. 65). This theory, for example, predicts that the burning rate of a small sphere will be proportional to the  $1/4$  power of  $g$ . The burning of larger items tends to be dominated by radiative transfer. Here the effects of gravity are much smaller and indirect. The only gravity effect will be if the sootiness of the flames or the shapes of the radiating bodies are affected; this, of course, is possible.

#### PRESENT PROCEDURES USED FOR TESTING SPACECRAFT COMPONENTS

At NASA, the flammability of spacecraft materials is assessed primarily using the methods of NHB 8060.1B (ref. 4). This Handbook provides several methods, both full-scale and bench-scale, for the flammability testing of solid materials. The full-scale procedures include a sectional mockup (Test 10) and a full cabin mockup (Test 11). Both tests are ignited using an electrically triggered solid ignitor. Bench-scale procedures include an upward propagation test (Test 1), a less severe downward propagation test (Test 2), a supplementary test for flash and fire point (Test 3), and special tests for electrical wire insulation (Test 4) and potting compounds (Test 5). Test 1 uses specimens 6.3 cm wide by 30 cm long and ignited at the bottom by either a solid ignitor (for oxygen-enriched atmospheres) or a Bunsen burner. A specimen is acceptable if it meets maximum burn time and burn length criteria. Specimens which fail these criteria may be qualified under Test 2, which relocates the ignitor to the top of the specimen and does not provide specific cutoff criteria. In all these Handbook tests, the test is to be conducted at the atmosphere which constitutes the worst-case condition.

The European Space Agency (ESA) initially adopted a set of bench-scale test procedures (ref. 19) that are somewhat different from those of NASA. The ESA basic test was the Limiting Oxygen Index test. While this is different from the upward burning Test 1 of NHB 8060.1B, the ESA method proceeded in an analogous fashion by describing a downward propagation test for materials that do not pass the basic test, and by supplementing with a special wire insulation test. Currently, however, ESA is using the NASA procedures for actual testing of materials (ref. 66).

#### POSSIBLE FUTURE DIRECTIONS

It is likely that the intensive development of new test methods and fire design procedures going on in the area of fire protection for buildings will have some impact on the state of the art of fire-safe design in the aerospace environment. Such applications will not be a direct use of design procedures developed for buildings, since these take into account neither the special

environments of concern in space missions nor the required criteria. The principles themselves, however, may well be introduced into newer generations of spacecraft standards. This can be expected because the new generation of tests coming into use in the building industry are not conceived of as dedicated "widget testers" but, rather, are intended to focus on the fundamental properties of materials as they relate to flammability. The most essential of these principles for bench-scale testing include the requirements for

- (1) Planar, thermally thick specimens
- (2) The testing of composites as composites, instead of testing individual layers
- (3) Simulated fire exposure to consist of a uniform, adjustable radiant flux
- (4) Design of tests to give one-dimensional heat transfer
- (5) Design of apparatus such that specimens do not melt out of holder or retreat from their ignition sources
- (6) The measurement of heat, species, soot and smoke on a per-gram basis
- (7) Use of oxygen consumption for measuring heat release rates
- (8) The selection of both irradiance conditions and test times to predict full-scale data
- (9) The focus on predicting volume-integrated full-scale variables (e.g., heat release rate) instead of point variables (e.g., temperature at a given station)

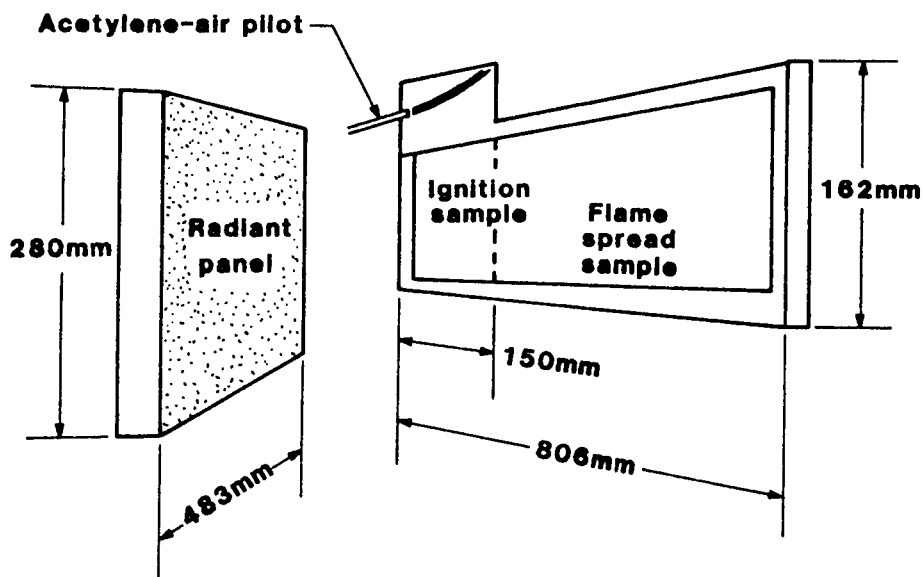

Figure 1. - International Maritime Organization flame spread apparatus.

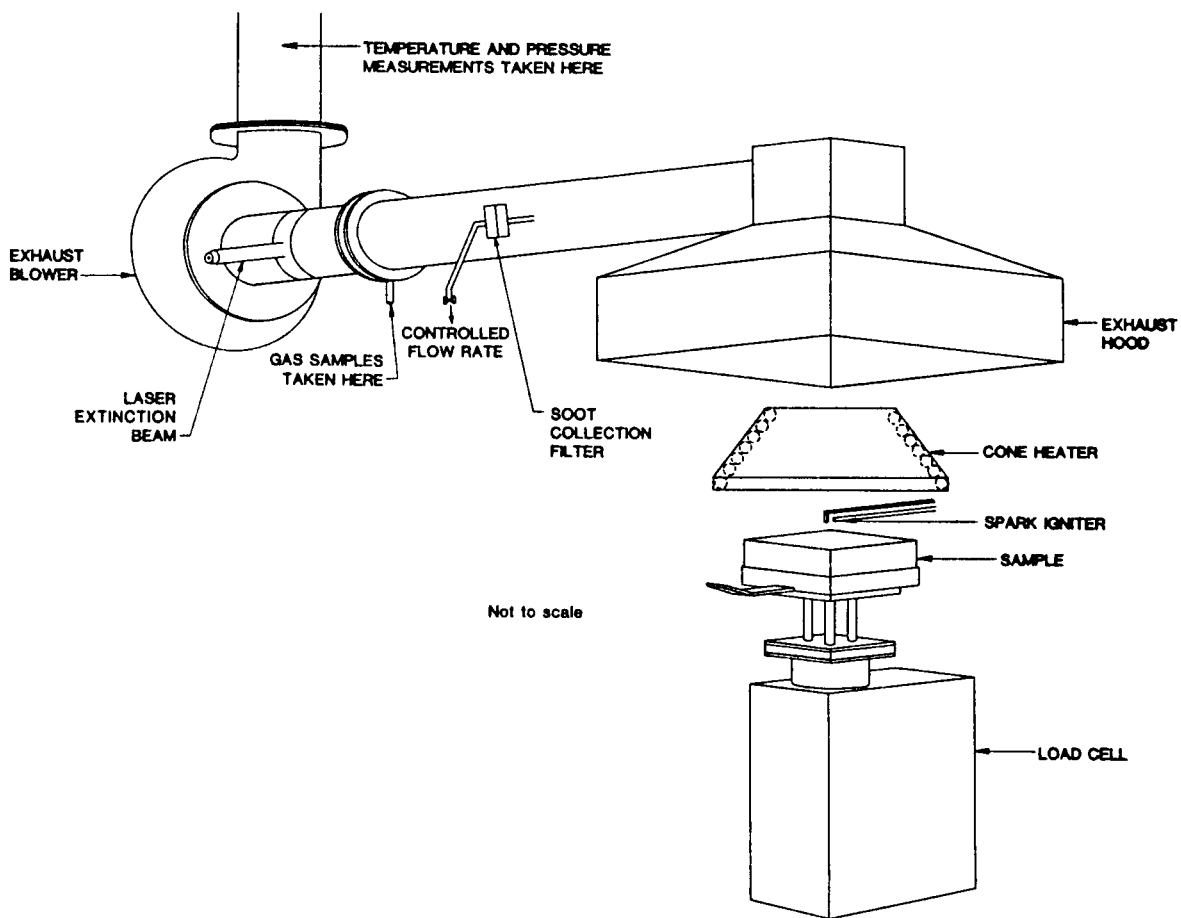

Figure 2. - Cone Calorimeter.

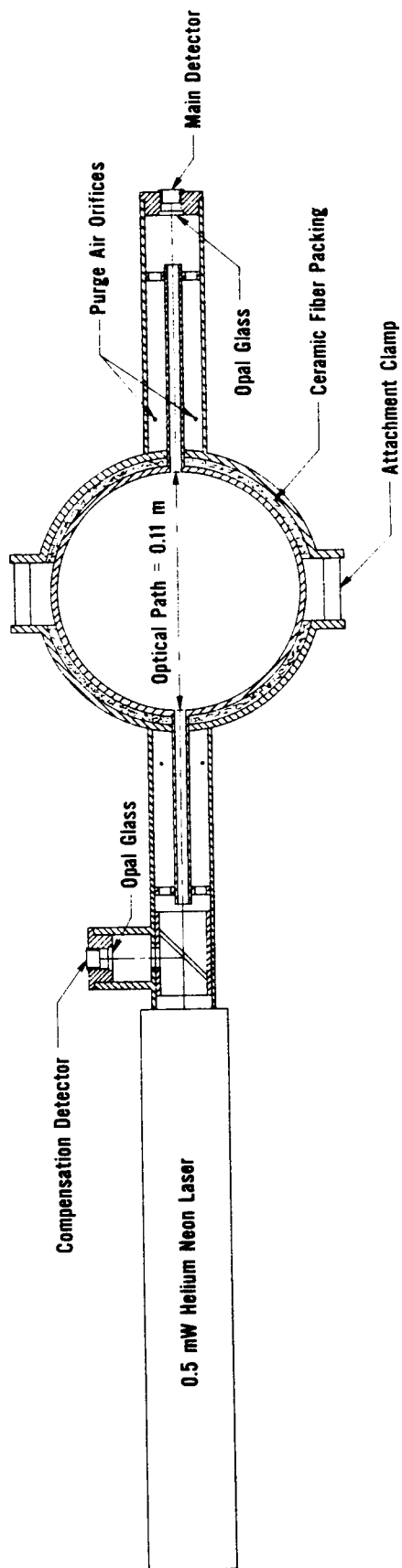

Figure 3. - Smoke extinction beam for the Cone Calorimeter.

## FIRE EXTINGUISHMENT AND INHIBITION IN SPACECRAFT ENVIRONMENTS

John de Ris  
Factory Mutual Research

## BACKGROUND

The confinement of personnel for long periods of time in the relatively small volumes of spacecraft introduces several unique hazards, in particular: (1) the continuous accumulation of trash, which might support combustion; (2) the extensive use of fire-retarded materials, which once ignited tend to produce very toxic products of combustion; and (3) the need to rapidly detoxify the cabin atmosphere immediately following a fire since (a) personnel escape is impractical, (b) venting to space with provision for replacement of the cabin atmospheres incurs a severe design weight penalty, (c) toxic products of combustion tend to be highly corrosive, and (d) the assigned spacecraft mission must presumably be continued.

In addition, the use of an artificial atmosphere inevitably introduces uncertainty as to the ambient oxygen concentration, which strongly influences the potential fire hazards. Materials and extinguishment methods must be tested under worst-case conditions corresponding to the maximum oxygen concentration. Figure 1 (from ref. 67) shows the strong influence of ambient oxygen concentration. Flame temperatures, material ignitibility, and burning rates depend primarily on the ambient oxygen concentration; hence combustion data are correlated by the horizontal zones in the figure, defined by limits of mole percent oxygen. Human breathing effectiveness, however, depends primarily on the partial pressure of oxygen, represented by the broken lines in figure 1 (a normal atmosphere has 21-kPa oxygen partial pressure). As a result one could noticeably decrease fire hazards by maintaining the partial pressure of oxygen corresponding to terrestrial conditions, while increasing the partial pressure of nitrogen to some higher value, perhaps to 200 to 300 kPa (2 or 3 atm). The dependence on total pressure (at low total pressures) indicated in figure 1 is primarily due to changes in buoyancy forces per unit volume. Fortunately, the reduction of buoyancy forces tends to reduce fire hazards, because less ambient oxidant is drawn into the flame zone for support of combustion.

The virtual elimination of buoyancy forces in a microgravity environment introduces important fundamental changes in combustion mechanism - even though a gentle breeze is usually present for ventilation purposes. It is clearly impractical to perform material acceptance tests (and perform realistic fire suppression tests) in a microgravity environment. As a result we must rely on a thorough theoretical and conceptual understanding of fire behavior mechanisms when extrapolating our terrestrial experience to spacecraft conditions. This demands a continuing basic research effort to provide a firm scientific foundation for any proposed extrapolations. For example, the reduced fluid flow rates under microgravity conditions result in longer flow residence times, probably reducing the effectiveness of extinguishing agents such as Halon 1301 that act by slowing gas-phase kinetic reaction rates. These longer flow residence times may also allow for more soot formation and greater fractional radiant heat transfer under microgravity conditions. Halon 1301, when introduced into gaseous hydrocarbon fuels, is known to strongly encourage soot formation

and probably increase the radiant heat transfer from the flames. While this augmented radiant heat transfer may tend to quench the flames, it is also likely to increase the soot and carbon monoxide output; and it may induce higher overall burning rates if the fire is large enough to be controlled by radiant heat transfer to the pyrolyzing solid fuel. These issues clearly demand further fundamental research.

As we approach the 21st century, activities in space will become increasingly routine. People will demand higher level of safety from unwanted fires. Even today astronauts receive very little fire safety training. Future manned spacecraft missions will be of longer duration, be likely to have more objectives, and be expected to survive accidental fires. Terrestrial fire-safety experience dictates that unwanted ignitions will occur and that the most difficult situations will be associated with unexpected fire scenarios. Presumably, all anticipated hazards can be controlled by careful design. Thus our major challenge at this time is to choose and develop a suitable general purpose fire-fighting technology that can be used to handle unexpected hazards with relatively little personnel training. Meanwhile, we should actively pursue the relatively easier challenges of designing specific fire protection measures for clearly identified hazards.

#### ELECTRONIC EQUIPMENT

Spacecraft generally have a lot of electronic equipment, which presents a likely source of fire ignition due to overheated components. Such equipment is generally in modularized compartments to insure its reliability and protect it from outside electrical, mechanical, and thermal disturbances. In general, one needs to gain access to the compartment interior only when there is a clearly identified faulty component that must be replaced or repaired. All other access generally occurs through panel controls, gauges, and connectors. Nowadays, terrestrial computers are sometimes fire-protected by installing self-contained automatic Halon 1301 canister extinguishers within the computer cabinet. Halon 1301, however, introduces severe toxicity and corrosion problems. Instead, it might be much more desirable to inert the atmosphere within the compartments through use of an onboard nitrogen inert gas generation system (OBIGGS), using molecular sieve or permeable membrane techniques to provide continuous purging. The compartments would have to be sealed and possibly provided with suitable heat exchangers. This approach would prevent ignition and reduce its concomitant damage, cleanup, and potential corrosion hazards. It would also minimize any fire-induced outgassing of halogens from circuit boards and cable insulation. The sealing of electronic compartments would be quite advantageous in terms of reducing corrosion problems within the compartment due to attack by extinguishing agents or products of combustion from fires taking place outside the compartment.

#### GENERAL-PURPOSE FIRE EXTINGUISHMENT

It is essential for spacecraft to be provided with a general-purpose fire extinguishing system that is capable of handling a very broad range of fire threats both in terms of origin and magnitude. The choice of extinguishing system needs to be made as soon as possible to allow time for technology development tailored to spacecraft environments. Present day general-purpose systems include water sprays, dry powder, foam, CO<sub>2</sub> or N<sub>2</sub> inerting, and Halon 1301.

Dry powder and water-based foam present definite cleanup problems in a spacecraft and will not be discussed further here.

### Gaseous Inerting

Nitrogen inerting has the advantage over carbon dioxide inerting of not requiring onboard storage of an additional gas. Nitrogen also introduces fewer physiological effects. It, therefore, has definite potential. Recently, the U.S. Navy has tested N<sub>2</sub>-pressurization as a method for combating submarine fire hazards and has found it to be quite effective. Figure 1 suggests that for deep-seated fires involving glowing combustion (incomplete combustion), oxygen concentration must be greatly reduced through extensive inerting. Currently, the U.S. Navy is not actively pursuing this approach because the onboard storage of extra nitrogen incurs a considerable weight penalty. Carbon dioxide would have an even greater weight penalty, and we shall not consider it further here. This leaves only Halon 1301 and water-sprays as candidate fire fighting agents, which we shall now consider in more detail.

### Halon 1301 (Bromotrifluoromethane, CF<sub>3</sub>Br)

Halon 1301 is a nonflammable gas that chemically inhibits gas-phase combustion by releasing bromine atoms, which can repeatedly scavenge OH radicals necessary for combustion. On a pound-for-pound basis, it is typically two-and-a-half times more effective than carbon dioxide as a fire-extinguishing agent. It is effective at a volumetric concentration of 6 percent against liquid-fuel (Class B) and electrical (Class C) fires as well as most surface fires involving ordinary combustibles (Class A). It is ineffective against deep-seated (Class A) fires because it does not directly cool the solid fuel and does not chemically impede glowing combustion reactions. Such glowing reactions are less important because they do not spread rapidly and can be extinguished with small amounts of water once a fire is otherwise under control.

Halon 1301 itself is noncorrosive. It is also the least toxic of the various types of Halons at their equivalent fire fighting concentrations. However, the products of combustion from fires being suppressed by Halons are highly toxic and corrosive. This means that one must achieve rapid fire suppression and make provision for immediately cleaning up the atmosphere after a fire. This is a very difficult technological task in a spacecraft environment, where one does not have ready access to a supply of fresh air for several volume changes while flushing the products out of an occupied cabin. If the personnel could retreat to a secure area of the spacecraft, the task would be made easier by venting all the contaminated atmosphere to outer space; however, all components of the spacecraft would have to be designed to withstand a full vacuum.

The most formidable obstacle to the use of Halon 1301 is the toxicity of the agent in its original "neat" state. Numerous studies (refs. 68 to 71) have been made on its toxicity, leading to the recommendations summarized in table I (refs. 68 and 71 to 73). Reference 69 states: "Three healthy male volunteers were exposed to Halon 1301 in a controlled-environment chamber for the purpose of monitoring their physiological and subjective responses to a series of Halon 1301 gas concentrations ranging from 1000 parts per million to 7.1 percent for periods of 30 minutes. The first untoward responses were observed to occur

during exposure to 4.3 percent and 4.5 percent. These consisted of a sensation of light-headedness and dizziness accompanied by a feeling of euphoria occurring within 2 minutes of exposure. Exposure to 4.5 percent for 10 minutes resulted in an impairment in tests of balance in one of the three subjects. A second subject evidenced mild impairment when exposed for an additional 20 minutes. Exposure to 7.1 percent produced mild changes in tests of balance in one individual and severe impairment in a second subject who concomitantly experienced a decrement in eye-hand coordination. In the well-lighted environmental chamber all subjects demonstrated their ability to safely exit over a 1-minute period from the contaminated zone. No untoward cardiovascular responses were observed. The untoward physiological and subjective responses observed were short-lived following cessation of exposure."

It is clear from these studies that a spacecraft would have to be provided with some means for chemically cleaning Halon 1301 from the atmosphere following the extinguishment of a small fire. The author is unaware of any such available technology for this purpose. It is for this reason that the U.S. Navy has not seriously considered using Halon 1301 for suppressing submarine fires.

#### Water Sprays

Water sprays are effective against fires involving ordinary solid combustibles (Class A), liquid fuels (Class B), and electrical fires (Class C). On a pound-for-pound basis, water hand-held extinguishers are about as effective as Halon 1301 extinguishers for surface fires and much more effective for deep-seated fires. Liquid water extinguishes fires primarily by cooling the vaporizing fuel. Water also cools the fire zone and surroundings as well as providing some smothering of the fire.

Portable hand-held extinguishers producing solid streams are not recommended for Class B and Class C fires. A short solid stream of water can splatter a pool of liquid fuel and might conduct electricity when in contact with a high voltage. However, solid streams are very useful when one wishes to project the water over long distances. Solid streams of city-water (containing electrically conducting ions) present a definite shock hazard when used within four feet of high voltage (600 V) equipment. Sprays are not hazardous. Shock hazards of accumulated water could presumably be significantly reduced by use of a deionizing water filter.

Fine sprays of water can be remarkably effective against vigorous fires in compartments. The U.S. Navy (ref. 74) has extinguished fully developed liquid hexane and heptane fires in 0.8-m<sup>2</sup> (9-ft<sup>2</sup>) and 2.2-m<sup>2</sup> (24-ft<sup>2</sup>) pans within 6- by 6- by 3-m (20- by 20- by 10-ft) enclosures within 9 sec at a water application rate of 1.3 l/sec (20 gal/min). Factory Mutual Research has demonstrated similar rapid extinguishment in its bedroom-fire test series. Apparently, the vigorous spray injection causes the fine drops to be deposited on all exposed surfaces preventing further fuel pyrolysis. Extinguishment occurs before enough water mist could accumulate in the gas volume to render it noncombustible. One would need to have one mass unit of liquid water mist for each three mass units of air to reduce the resultant equilibrium flame temperature to below 1500 K, which is around the temperature necessary to prevent gaseous combustion. Test observations indicate extinction occurs with far less water. Generally, one needs an order of magnitude less water if the water is



used for direct cooling of the pyrolyzing or vaporizing surface. Fine sprays are less effective for shielded fires, although they do cool the surroundings and allow access for manual extinguishment.

The most significant advantages of water sprays for spacecraft fire extinguishment are the absence of adverse toxicological effects, the natural scrubbing action of water drops in cleaning the atmosphere, the ease of agent cleanup using the spacecraft ventilation system dehumidifier, the small mass of agent needed, and the fact that ample liquid water is already available on the spacecraft for other purposes so that little weight penalty is involved for fire protection. Electronic equipment subjected to water sprays generally recovers full functionality after the liquid water dries out. As discussed earlier, it might be desirable to keep spacecraft electronic equipment in sealed inert gas containers to avoid taking the equipment even temporarily out of service.

The use of water sprays in microgravity environments introduces a variety of scientific issues. There is a vast literature on the behavior of liquid sprays. Computer models are available (refs. 75 and 76) for calculating spray dynamics with and without gravity. These models follow individual typical drop trajectories and include effects of turbulence on the gas-flow dynamics. A suitable water pressure, spray angle, and orifice diameter need to be chosen to provide the desired nozzle water-flow rate and drop diameter leading to rapid deposition of water on exposed fuel surfaces. It might be desirable to employ a hose line with an adjustable nozzle similar to that of a garden hose to control the water flow rate and throw distance of the spray.

It would be useful to employ these computer models to study the effects of water-flow rate, drop size, and spray momentum on the speed and uniformity of water deposition on shielded and unshielded surfaces with and without the presence of forced ventilation. Very fine drops can be carried by the general gas motion behind shielded surfaces, but they will settle out (or be flung out) more slowly. Large drops tend to travel in more straight lines, directly impacting unshielded surfaces with little, if any, water reaching shielded surfaces. The spray itself can generate considerable gas motion. It would be interesting to know whether there is an optimum drop-size range leading to relatively fast and uniform surface deposition. In particular, one would like to know how this optimum drop size depends on the presence or absence of gravity. Conclusions drawn from such a mathematical study could certainly provide insight useful in selecting a practical spacecraft water spray fire protection system.

The U.S. Navy favors the use of fine-drop water sprays for submarine fire protection and is currently developing a fixed-nozzle high-pressure system (ref. 74). The needs and constraints of NASA are quite similar to those of the U.S. Navy. It is recommended that NASA seriously consider the adoption to a hose line and water spray for its general-purpose fire protection needs.

## CONCLUSIONS

It is essential that NASA develop a comprehensive approach to fire extinguishment and inerting in spacecraft environments. Electronic equipment might readily be protected through use of an onboard inert gas generating system (OBIGGS). The use of Halon 1301 presents serious technological challenges for

agent cleanup and removal of the toxic and corrosive products of combustion. Nitrogen pressurization, while effective, probably presents a serious weight penalty. The use of liquid water sprays appears to be the most effective approach to general-purpose spacecraft fire protection.

TABLE I. - ALLOWABLE HALON 1301 EXPOSURES

Organization	Concentration, vol %	Time	Reference
OSHA	0.1	8 hr/day, 40 hr/wk	72
NFPA(12A)	Up to 7 7 to 10 10 to 15 >15	15 min 1 min 30 sec 0	73
FAA	Product of percent and minutes	≤10	71
U.S. Air Force	6	5 min	68

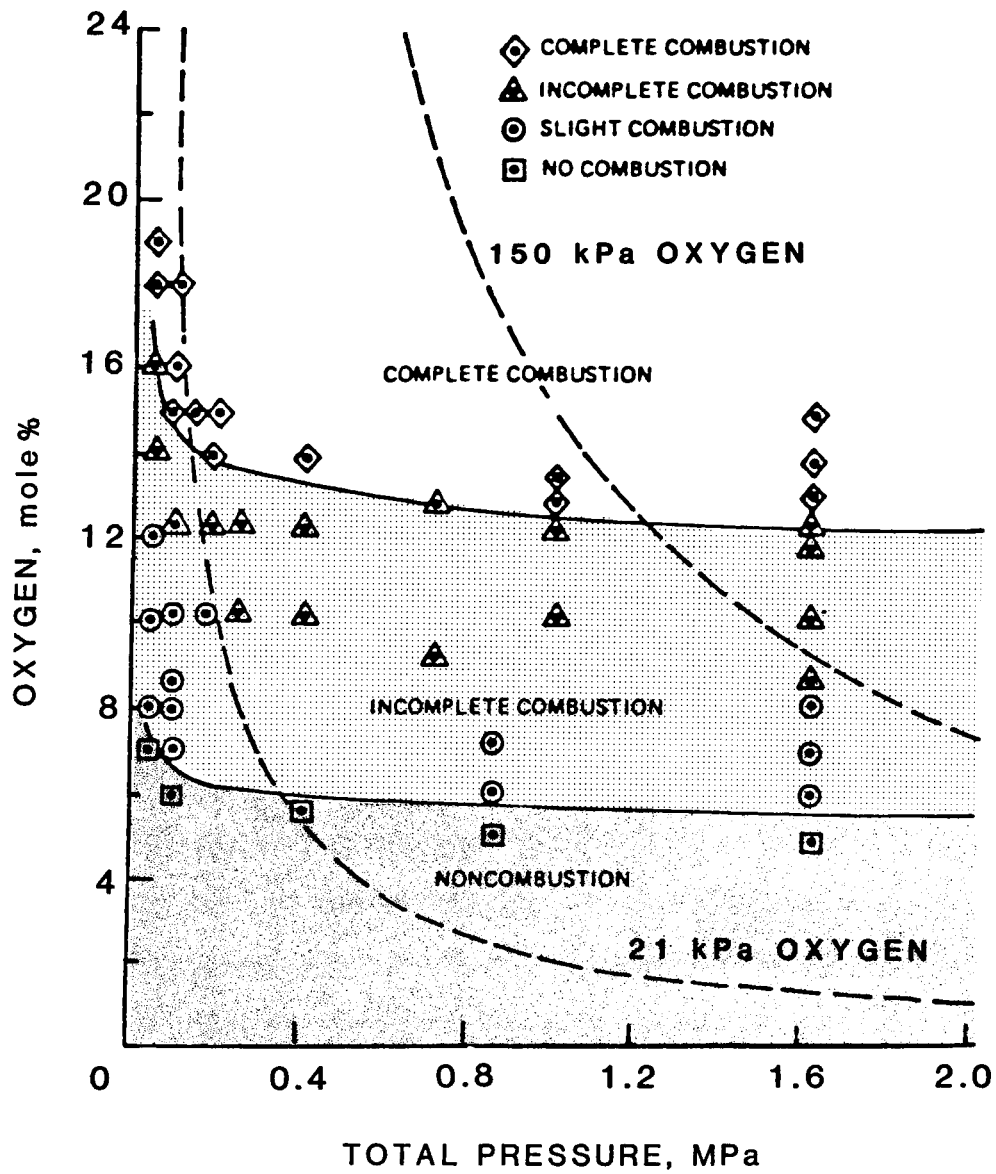

Figure 1. - Varying degrees of combustion in an oxygen-nitrogen atmosphere (ref. 67).

## INERTING AND ATMOSPHERES

Homer W. Carhart  
Naval Research Laboratory

The old aphorism that an atmosphere that will sustain a fire will also sustain life, and vice versa, has been held as fact for a long, long time. Fortunately, this is not true. Fires are dependent primarily on the concentration of oxygen, whereas life is dependent on the partial pressure of oxygen. The two are not synonymous. Before discussing this in more detail, let us first consider that man seems to be ever more determined to encapsulate himself and then place the capsule in exceedingly hostile (if not immediately lethal) surroundings, be it a submarine, a space capsule, or even a high-flying aircraft. Examples of three of these capsules and their internal environments are given in Table I.

The fatal Apollo fire in 1967 in 100 percent oxygen lasted only about 15 sec (ref. 77). Fires in submarines are comparable to those we experience ourselves every day, the atmosphere being essentially air; but in the case of SeaLab, the aquanauts, wanting to smoke, could not even strike a match (ref. 78). All three of these atmospheres supported life for extended periods (the partial pressures of oxygen being close to the same), yet from a fire standpoint, the first was almost explosive and the last would not even support attempted combustion. From table I it is apparent that fire is dependent on the percent of oxygen, whereas life is dependent on the partial pressure of oxygen.

It follows, then, that in an inhabited capsule it should be possible to exercise a certain amount of willful control over fire and still maintain habitability by proper selection of the composition of the atmosphere. This leads to two concepts in the control of fires in confined spaces by controlling atmospheric composition: the first, to lower the overall potential hazard by maintaining the percent oxygen in the capsule below that of air, and the second, to provide for the emergency extinguishment of a fire by sudden flooding with nitrogen. For both cases we are very fortunate that fires are much more sensitive to changes in concentration of oxygen than people are to changes in partial pressure of oxygen. This allows for considerable flexibility in use and control of the atmosphere.

Figure 1 shows the burning rate of paper (held horizontally) as a function of oxygen concentration (refs. 79 and 80), and figure 2 shows that of a liquid fuel (kerosene) at two different total pressures (data from unpublished study by R. Corlett, University of Washington). Figure 3 shows the effect of total pressure on burning of paper at three different oxygen levels (ref. 80). It can be seen from the steepness of the lines in figures 1 and 2 that burning rate is indeed very oxygen sensitive, whereas figure 3 shows that total pressure has a much lesser effect. Slight changes in oxygen concentration also impact on fire parameters other than burning rate, for example, rate of heat release and maximum flame temperature, induction time, minimum ignition temperature, and flammability limits (ref. 81).

The concept of Oxygen Index (i.e., the lowest concentration of oxygen that will just barely support combustion of a given material) is also invoked. Some materials that might burn at 21 percent oxygen, the sea-level air concentration, might not at lower values (cf. table II).

It has been shown by many experimenters (refs. 82 and 83) that hydrocarbons (e.g., gasoline) will not burn below 12 to 14 percent oxygen. If the 14-percent value is selected (i.e., 7 percent less than the 21 percent of air), the argument can be made that if one were to lower the oxygen concentration to say 19 percent in a closed environment, this might represent a 2/7 drop in oxygen effectiveness, roughly 30 percent. Does this mean we could get a 30-percent protection in fire spread, heat release, etc.? This is a surprisingly large effect considering how little we changed the percent of oxygen.<sup>1</sup>

On the other hand, as shown in table III, man is surprisingly tolerant of changes in partial pressure. Granted that a sudden change, for example, from sea level to 3700 m, might cause "mountain sickness" in unconditioned people, adaptability to change is still surprisingly fast.

This leads to the two concepts mentioned earlier: (1) long-term protection and (2) emergency extinguishment. At the Naval Research Laboratory, for parochial reasons, we have proposed that submarines operate continuously at 19 percent oxygen (~1-atm total pressure) or slightly below, rather than the maximum 21 percent permitted now. The reason for choosing 19 percent is somewhat arbitrary - it is based on cigarettes still being able to smolder somewhat. Thus, the crew would not have to forego smoking. After all, a smoldering cigarette is also a fire, and at lower oxygen levels it too goes out, with interesting psychological effects on the crew (cf., the first sentence in this paper). For nonsmoking crews in other capsules, the 19-percent-oxygen restriction would not apply. That 19 percent oxygen is quite acceptable to submarine crews has been shown repeatedly by submarines operating under this condition for stretches of 24 hr or longer, often without the crews being aware of it. This is documented by the atmosphere habitability logs of operating submarines.

The bottom line is that we can indeed slow fires down markedly by diluting the atmosphere with an inert gas, such as nitrogen, as long as we stay within physiologically acceptable levels. This buys time, if nothing else, and could spell the difference between an incident and a disaster.

In connection with the concept of sudden extinguishment, our Laboratory has proposed a system that, in the event of a runaway fire in a submarine, will dump 50 kPa (0.5 atm) of nitrogen suddenly into the compartment (ref. 84). Table IV shows the concept. Adding 0.5-atm nitrogen raises the total pressure to 1.5 atm. The concentration of oxygen drops to 14 percent, but the partial pressure of oxygen stays the same. As stated earlier, 14 percent oxygen is in the ball park for the oxygen index for hydrocarbons (ref. 82), and many other combustibles, so the fire should go out. However, experimentation has shown there is a marked scaling effect (ref. 85), as seen in figure 4, but even Class B (liquid fuel) fires are extinguished at about a total pressure increase

---

<sup>1</sup>It is recognized that scientifically this is spurious reasoning, but the interesting fact is that what limited data are available tend to bear these numbers out (e.g., figs. 1 and 2).

of 0.7 atm in large chambers. In our diving community this is equivalent to only about 6.7 m (22 ft) of water. The penalty for this system in space applications is that the tankage needed to carry this extra nitrogen would add weight to a capsule. An advantage, however, is that, unless very toxic fire gases are produced, the crew could still live in this atmosphere. This has been demonstrated using rats as test subjects in a chamber in which a sizeable jet fuel fire was extinguished with nitrogen with no ill effects on the rats (ref. 86). Fortunately, or not, we must recognize that the physiology of rats and humans is not that different, so we should be able to extrapolate these results to humans.

Two very significant problems we have demonstrated with fires in confined spaces are that fires get out of hand very much faster than in more normal environments and that temperatures quickly reach lethal levels (ref. 87). Figure 5 shows data for hull insulation fires in a 325-m<sup>3</sup> chamber. The contrast between open and closed hatch operations is very real, and certainly air temperatures of 700 to 800 °C, even for a few seconds, are quickly lethal. (Most previous and extensive "closed" fire experiments have not been performed in hermetically sealed compartments and, therefore, we have been consistently misled about the true ferocity of such fires).

It must be emphasized, of course, that all these experiments and discussions are based on normal gravity. What the effects of low gravity would be remains to be determined.

TABLE I. - ENCAPSULATED ENVIRONMENTS

Capsule	Total pressure		Oxygen, <sup>a</sup> vol %	Oxygen partial pressure <sup>b</sup>	
	kPa	atm		kPa	atm
Apollo	30	0.3	100	30	0.3
Submarine	100	1.0	21	20	.2
Sealab II	710	7.0	4	30	.3

<sup>a</sup>Fires depend on minimum oxygen concentrations.

<sup>b</sup>Human life depends on minimum oxygen partial pressure.

TABLE II. - OXYGEN INDICES

Filter paper . . . . .	18.2
Cotton . . . . .	18.6
Rayon . . . . .	18.9
Sugar . . . . .	22.0
Red oak . . . . .	22.7
Wool . . . . .	23.8
3/4-in. plywood . . . . .	24.3
3/8-in. plywood . . . . .	29.2

TABLE III. - OXYGEN PARTIAL PRESSURE IN INHABITED ATMOSPHERES

	Oxygen partial pressure		Elevation	
	kPa	atm	m	ft
Apollo, takeoff mode	110	1.09	----	-----
Apollo, flight mode	30 to 37	0.3 to 0.37	----	-----
Sea level	21	.21	0	0
Denver, Colorado	18	.175	1520	5 000
Quito, Ecuador	15	.15	2800	9 300
La Paz, Bolivia	14	.134	3660	12 000
Pikes Peak, Colorado	13	.123	4300	14 100

TABLE IV. - EFFECT OF NITROGEN ADDITION

	Capsule pressure		Oxygen, vol %	Oxygen partial pressure	
	kPa	atm		kPa	atm
Start	101	1.0	21	20	0.2
Add N <sub>2</sub>	51	.5	--	--	---
Final	152	1.5	14	20	.2

<sup>a</sup>Equivalent to 4.9 m (16 ft) water.

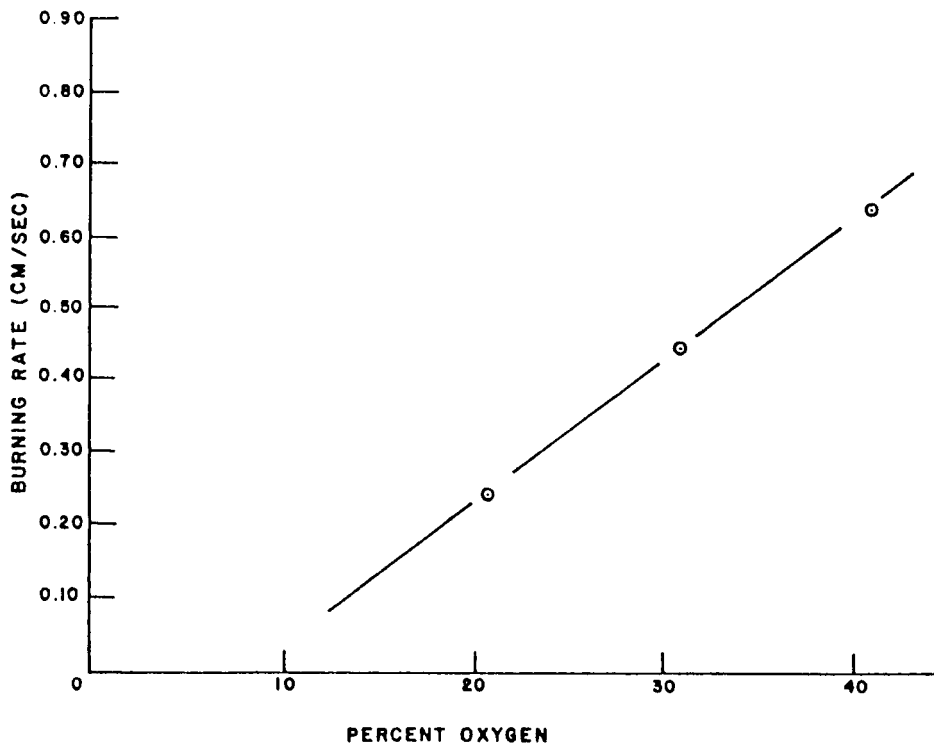

Figure 1. - Burning rate of paper as a function of oxygen concentration at 101 kPa (1 atm).

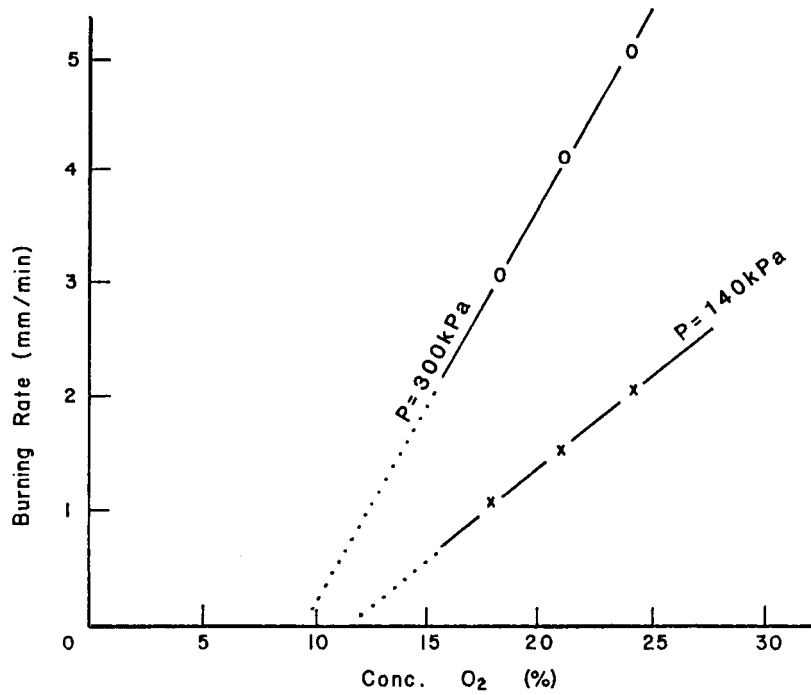

Figure 2. - Burning rate of kerosene as a function of oxygen concentration.



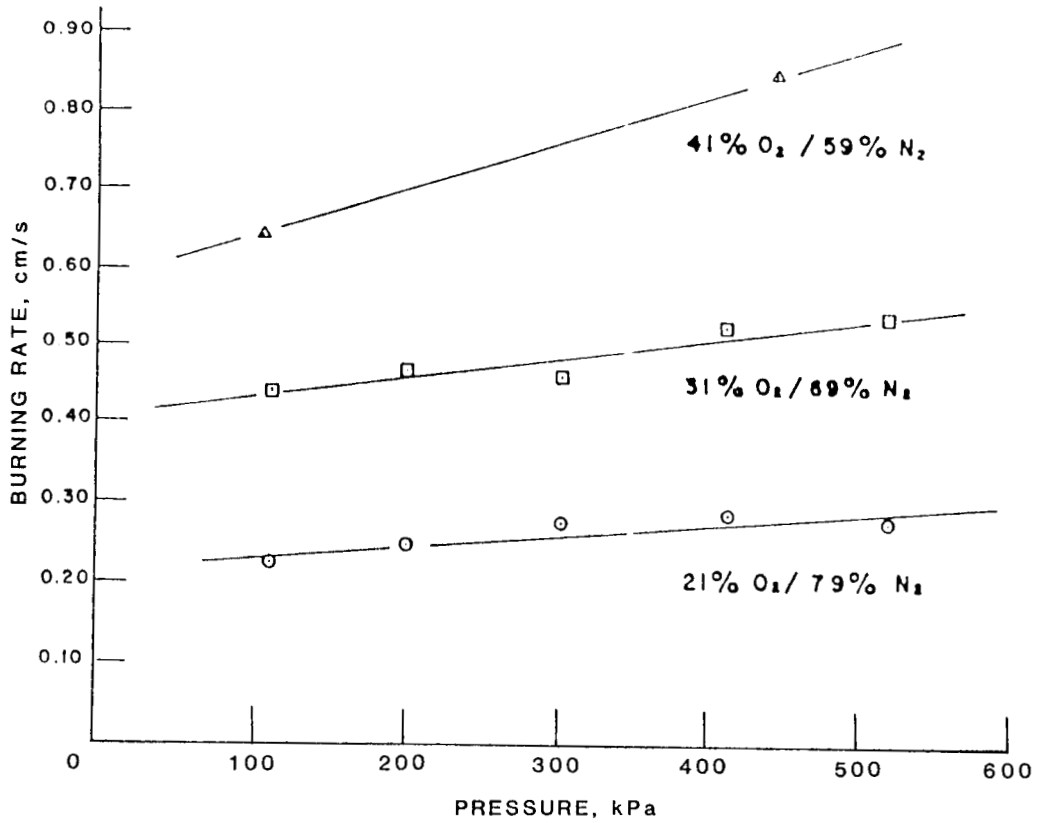

Figure 3. - Burning rate of paper as a function of oxygen concentration and pressure.

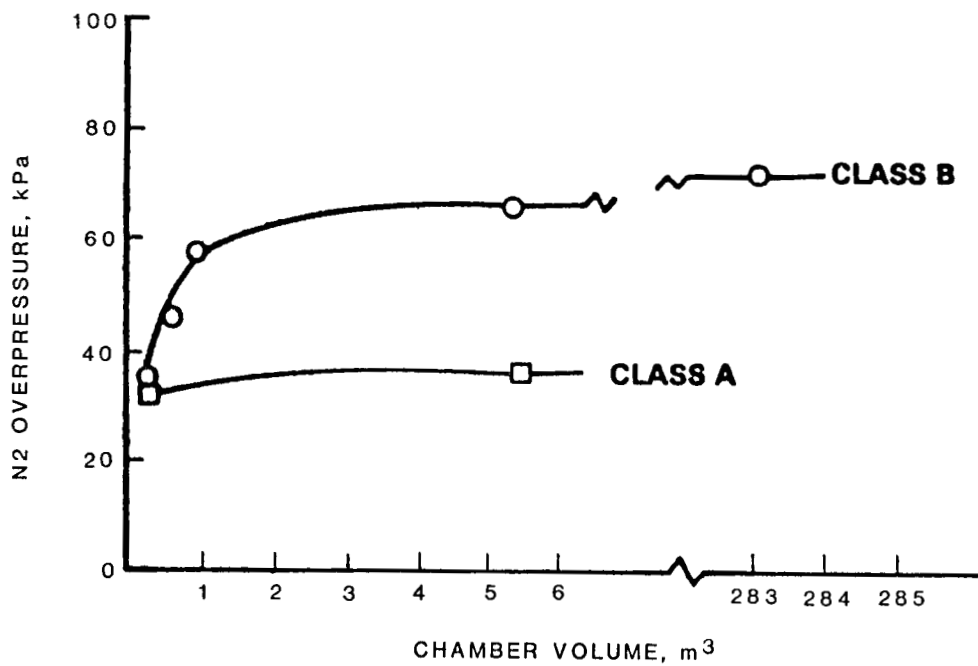

Figure 4. - Nitrogen overpressure necessary to extinguish Class A and Class B fires in various-sized chambers.

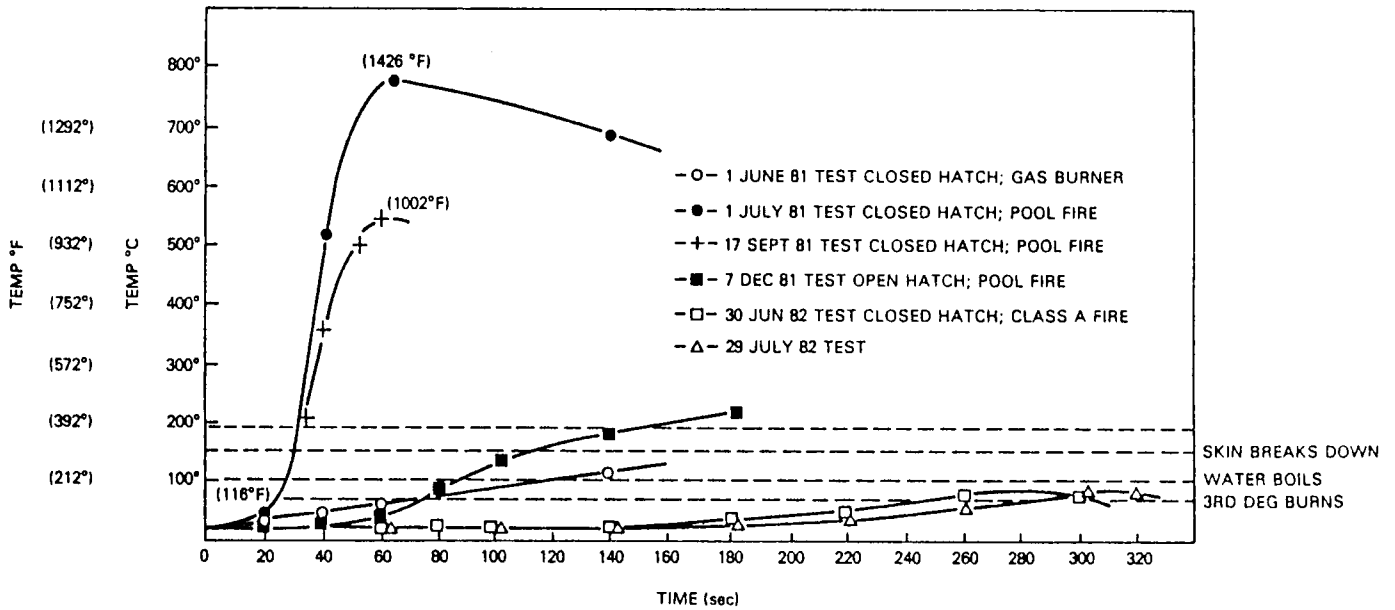

Figure 5. - Temperature histories in various tests in 352-m<sup>3</sup> chamber.

## FIRE-RELATED MEDICAL SCIENCE

Douglas R. Knight  
Naval Submarine Medical Research Laboratory

Space crews must quickly extinguish in-flight fires in order to prevent serious burns and smoke inhalation. Otherwise, fire victims may require medical skills and supplies that exceed the capabilities and resources of the surviving crewmembers.

Man's efforts to combat or escape fires are usually futile when flames develop in oxygen-rich atmospheres, for the simple reason that lethal temperatures are produced within 60 sec of the onset of combustion (refs. 88 to 90). Even in an atmosphere of 20 percent oxygen - 80 percent nitrogen, dangerous temperatures can evolve in an astoundingly short period of time. Earth-based engineering studies (ref. 91) have shown that the threshold temperature for skin injury develops within 30 to 90 sec of ignition, depending on the configuration of the test chamber. High temperatures evolve more quickly when the fire chamber is sealed than when its hatches are open to ambient air. This is shown in figure 1, which plots selected data from figure 5 of the preceding report *Inerting and Atmospheres*. The difference in skin injury between 30 sec of exposure (hatches closed) and 90 sec of exposure (hatches open) could mean the difference between death and survival of those fighting the fire.

Brief exposures to fire may be lethal within 1 to 5 min when the ambient temperature exceeds 200 °C (fig. 2). The postulated mechanism of death, hyperthermia, is lethal to test animals when rectal or heart-blood temperature exceeds 42.5 °C. The final cause of death is either circulatory failure, from ventricular fibrillation, or agonal collapse of blood pressure (ref. 92).

Inadequate respiratory protection, space sickness, and panic may predispose crewmembers to incapacitation, injury, and death by smoke inhalation. Smoke inhalation has been a leading cause of death in victims of urban fires (refs. 93 and 94). Massive exposures may interfere with lung function when smoke particles mix with secretions to plug the airways. Otherwise, particulates act as irritants, obscure vision, and induce panic (ref. 95). Firefighters have been exposed to a number of harmful gases in smoke, including carbon monoxide, acrolein, hydrochloric acid, and other asphyxiants/irritants (table I). Smoke suffocates victims since it is deficient in oxygen and contains high concentrations of carbon dioxide (refs. 96 and 97). However, carbon monoxide accounts for the majority of deaths occurring within six hours of exposure to cellulosic fires. It asphyxiates the body by blocking oxygen's reactions with hemoglobin and cellular proteins. Hydrogen cyanide, also an asphyxiant, has not been a prevalent cause of early deaths (ref. 98). Acrolein is considered to be the most serious irritant found in smoke, because of its potency in producing intolerable lacrimation and nasal irritation (refs. 95 and 96). The release of acrolein depends on fire temperature and fuel composition (ref. 98).

Spacecraft interiors may contain synthetic polymers that yield high concentrations of toxic gases when burned. There is already an account of the release of lethal concentrations of nitrogen dioxide from x-ray film burned in

the Cleveland Clinic fire (refs. 95 and 98). Halogenated acids, such as hydrochloric acid, may act as strong sensory irritants when released by the combustion of halogenated polymers. Isocyanates, ammonia, and cyanides have been produced by the burning of nitrogenous polymers.

Any flame might cause an explosion by igniting reactive substances (e.g., propellant fumes) that accumulate in spacecraft atmospheres (ref. 99). Tissues that line gas-filled spaces in the body are particularly vulnerable to injury by blast waves (table II). Consequently, the lung may sustain sufficient damage to impede oxygenation of hemoglobin and release bubbles of air into the arterial blood stream (ref. 100). The bubbles interfere with heart and brain activity by obstructing nutrient blood flow through the tissues. More frequently, however, blast waves cause serious injury by tossing the body against firm surfaces or releasing high-speed fragments that penetrate the tissues.

Structural failures in burning buildings can impede the movement of victims or injure firefighters; but in the weightless conditions of space travel, weakened structures would not shift as a result of gravitational forces.

The time-of-useful-function indicates how long victims have to escape a fire before their only hope for survival is rescue (ref. 93). Medical scientists have studied the ability of experimental animals to escape fires as a biological end-point of combustion toxicology tests. For example, toxic gases may impose one or more forms of hypoxia, which impair animal coordination. Overwhelming irritation of the eyes and airways may also impair escape (ref. 98). But, combustion products can diminish mental acuity and degrade human judgment before there is overwhelming irritation and neuromuscular incoordination. Rather than studying the escape behavior of animals, why not evaluate the early effects of smoke inhalation on human performance?

Spacecraft fire safety may be improved by the use of a fire-retardant atmosphere in occupied spaces. Low concentrations of oxygen can protect humans from fire damage by reducing the rate and spread of combustion, but care must be taken to avoid the hypoxic effects of oxygen-lean atmospheres. Crews could live and work in 11 percent oxygen if barometric pressure were adjusted to maintain the partial pressure of oxygen ( $P_{O_2}$ ) above 16 kPa (0.16 atm) (fig. 3). Eleven percent oxygen should prevent most types of fires, since 15 percent oxygen retards the combustion of paper and 13 percent oxygen extinguishes pentane flames (refs. 89, 91, and 101). Studies at the Naval Submarine Medical Research Laboratory are defining (a) a safe, minimum  $P_{O_2}$  at normobaric pressures; (b) a maximum barometric pressure for use without risk of nitrogen narcosis/decompression sickness; and (c) the health effects of breathing trace levels of atmosphere contaminants in low concentrations of oxygen. To date, the results indicate that seated humans can perform mental tasks in atmospheres containing 11.5 percent oxygen. Although this strategy of fire safety is under consideration for submarines, it could be adapted to spacecraft once operational procedures define a maximum hyperbaric pressure and fire research defines the effects of reduced oxygen concentrations on combustion in low-gravity environments. Additional research is necessary to define man's tolerance of fire-inert atmospheres in the space station.

## GLOSSARY

- ANEMIC HYPOXIA** - a deficiency of oxygen due to reduced content of hemoglobin (e.g., hemorrhage) or inhibition of oxygen uptake by hemoglobin (e.g., the action of carbon monoxide).
- ASPHYXIA (SUFFOCATION)** - the consequence of hypoxia combined with an increased tension of carbon dioxide in the blood and tissues.
- BRONCHOCONSTRICTOR** - a gas that induces resistance to air flow through the respiratory passages, either by consequences of nerve stimulation or release of histamine (e.g., ammonia, sulfur dioxide).
- HISTOTOXIC HYPOXIA** - the blockade of oxygen utilization caused by the poisoning of cellular respiration (e.g., the action of hydrogen cyanide).
- HYPERTHERMIA** - an abnormally high body temperature.
- HYPOXIA** - the failure of tissues, for any reason, to receive an adequate supply of oxygen.
- HYPOXIC (ARTERIAL) HYPOXIA** - the consequence of reduced oxygen tension/content in arterial blood, due to (a) low partial pressure of oxygen in breathing gas, (b) abnormal lung function, or (c) shunting of venous blood into arterial stream.
- IRRITANT** - a gas that inflames tissues by direct contact, ordinarily the surfaces of skin and mucous membranes.
- PULMONARY IRRITANT** - a gas that stimulates sensory nerves in the lower respiratory tract and causes pulmonary edema (e.g., nitrogen oxides).
- RESPIRATORY IRRITANT** - a gas that acts as a SENSORY IRRITANT, PULMONARY IRRITANT, and BRONCHOCONSTRICTOR (e.g., chlorine).
- SENSORY IRRITANT** - a gas that stimulates sensory nerves in the face and upper respiratory tract, causing discomfort and slowing of the ventilation rate (e.g., acrolein, HCl).
- SMOKE** - a complex mixture of the airborne solid and liquid particulates and gases evolved when a material undergoes pyrolysis or combustion. The composition of smoke depends on the conditions of combustion.
- STAGNANT (CIRCULATORY) HYPOXIA** - a deficiency of oxygen caused by the slowing of blood flow through tissues.

TABLE I. - COMBUSTION PRODUCTS ENCOUNTERED BY URBAN  
FIREFIGHTERS

[The data were tabulated from ref. 96.]

Combustion product	Concentration		Limits of exposure, ppm	
	ppm	mg/m <sup>3</sup>	ppm	
			IDLH <sup>a</sup> (30 min)	STLC <sup>b</sup> (10 min)
Acrolein	0.1	14	5	30 to 100
HCN	.1	4	50	350
NO <sub>2</sub>	.2	10	50	>200
HCl	1	200	100	>500
CO	5	5 000	1 500	5 000
Benzene	.2	175	2 000	20 000
CO <sub>2</sub>	1000	75 000	50 000	100 000
Particulates	20	18 000	-----	-----

<sup>a</sup>Immediate danger to life or health (IDLH) is the concentration from which an unprotected worker might escape within 30 min without irreversible health effects or any physiologic effects that would impede escape.

<sup>b</sup>Short-term lethal concentration (STLC) is a 10-min exposure limit.

TABLE II. - ESTIMATED BLAST EFFECTS IN MAN

[Adapted from ref. 100.]

Effect	Overpressure	
	kPa	psi
Ruptured ear drum	>35	>5
Tiny hemorrhages in lung	80 to 110	12 to 16
Isolated hemorrhage in lung	140 to 210	20 to 30
LD <sub>50</sub> , boggy lung, emphysema	320 to 340	46 to 50
Death	690 to 830	100 to 120

( AIR TEMPERATURE, °C )

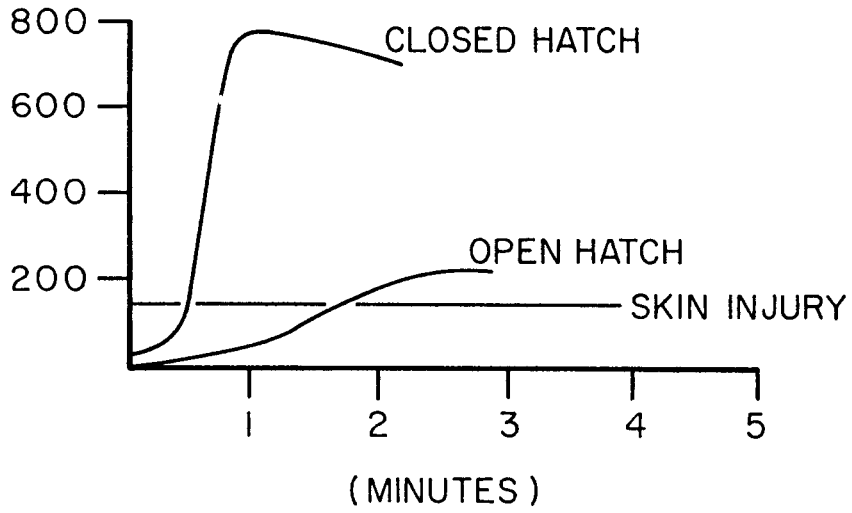

Figure 1. - Effect of chamber configuration on air temperature in submarine hull insulation fires (ref. 91).

( AIR TEMPERATURE, °C )

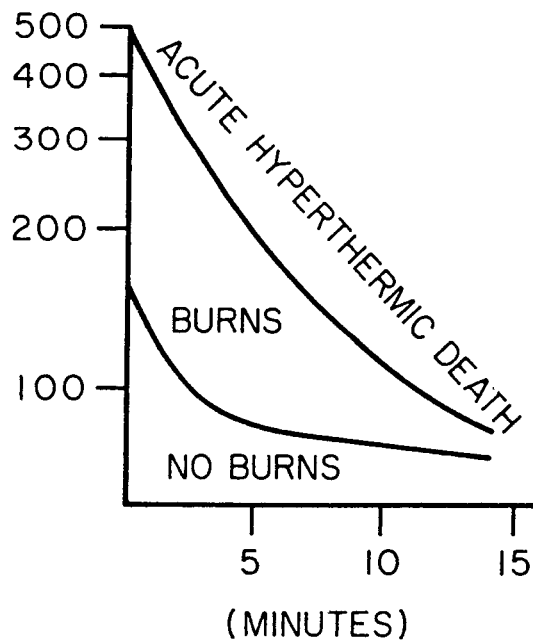

Figure 2. - Temperature-time relationship for heat injuries (ref. 92).

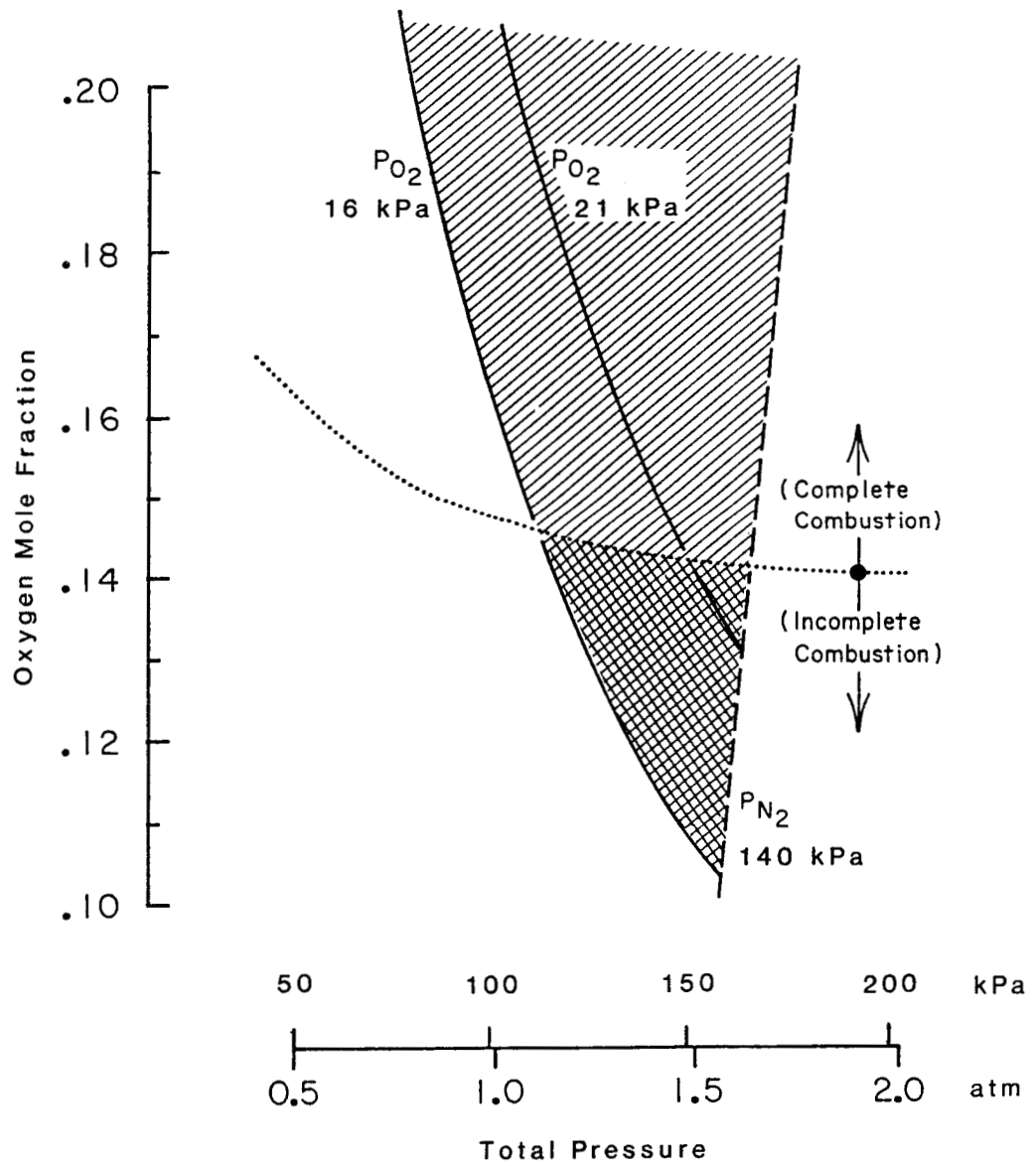

Figure 3. - Human life-support zones and flame retardant atmospheres.



## AIRCRAFT FIRE SAFETY RESEARCH

Benito P. Botteri  
Air Force Wright Aeronautical Laboratories  
Aero Propulsion Laboratory

## INTRODUCTION

Aircraft systems inherently possess a variety of potential fire and explosion hazards, which from time to time contribute to equipment and property damage and/or personnel injuries and fatalities. Historically, aircraft mishaps have frequently triggered intense research and engineering efforts directed at improving selected aspects of the overall fire protection problem. For military aircraft, the fire and explosion damage and loss experiences in combat, such as in southeast Asia in the late 1960's and early 1970's, provided additional impetus for the enhancement of survivability under various hostile threat operational environments. Today's civil and military aircraft are exemplary both in performance capability and overall system safety, of which fire safety is a key ingredient. Although aircraft fire safety problems are largely more diversified than those anticipated with spacecraft, per se, it is intended that by reviewing key aspects of recent aircraft fire safety research activities, the general philosophy of approach, if not the specific results, could contribute to the identification and resolution of spacecraft fire hazard concerns.

## NATURE OF THE PROBLEM

The aircraft fire and explosion threat is complex and diversified, involving a variety of materials (fuel, engine and hydraulic oils, interior cabin materials, metals, etc.), which are subjected to a broad span of natural and induced operating environment conditions and potential exposure to a number of ignition sources. The latter, for example, can include electrical arcs and sparks, friction sparks, hot surfaces, and open flames. In the case of military aircraft, combat operations introduce significant additional means for fire/explosion initiation. Achievement of an effective fire protection posture necessitates "early" and "heavy" emphasis on fire prevention, supplemented as necessary by fire hardening, detection, extinguishment/suppression, and control measures.

## AVIATION FUELS

In addressing the aircraft fire safety issue, priority attention must be given to the fuel onboard because of its large quantity, widely dispersed distribution, and relatively high fire/explosion hazards. Table I summarizes typical properties of military jet fuels that are deployed operationally or are undergoing research and development (R&D). A low flash point, volatile fuel, JP-4, is still largely utilized by the military because of worldwide availability and performance considerations. A kerosene fuel similar to commercial Jet A-1 fuel, JP-8, is utilized in the United Kingdom and is being considered for NATO-wide use in the very near future. The JP-8 fuel, like

JP-5, which is utilized by the Navy for safer aircraft operations off of carriers because of its higher flash point, offers considerable safety advantage. Air Force fuel R&D activities have recently focused on the use of (1) alternate sources such as oil shale, tar sands, and coal liquids as a means for assuring future, secure, domestic supply of acceptable quality jet fuels; as well as (2) the development of a high density, naphthenic-based fuel (referred to as JP-8X) offering a volumetric energy density up to 15 percent greater than JP-4.

For military aircraft, gunfire/projectile impacts can induce both ullage explosions and dry bay fires. The generation of flammable fuel-air mists within the fuel tank as a result of projectile penetration also renders low-volatility fuels vulnerable to ignition; although, in general, the fire hazard is considered to be less with the higher flash point fuels. During aircraft crash situations, similar external dispersion of fuel in air can occur as a result of fuel tank rupture and structural failure. The latter renders low-volatility fuels susceptible to ignition and a rapid fireball-flame spread response, thereby compromising crew and passenger safety under what in some instances would have been an impact-survivable situation. Over the years, various approaches have been investigated to render jet fuels safe. Most recently, the major effort in this area has been through a cooperative program between the United States and the United Kingdom to determine the feasibility of developing antimisting fuels using a British-developed antimisting kerosene (AMK) additive in a Jet A, low-volatility, fuel. This program progressed to the full-scale testing stage involving a controlled impact demonstration with a Boeing 720 at Edwards AFB, California in 1984. The Boeing 720 flew successfully using the treated fuel; however, the degree of fire protection provided by the AMK fuel was judged to be inadequate for the Federal Aviation Administration (FAA) to proceed with rule making at the present time. The FAA sponsored a Fuel Safety Workshop in the fall of 1985 to help shape a future program of activity in this area. The details of the planned future program have not been officially announced.

Air Force fuel R&D activities are currently also focusing on the needs of future supersonic and hypersonic vehicles. For these applications, in addition to the usual desired performance properties, a fuel will need to provide a high heat-sink capability. A typical fuel heat-sink requirement trend for high-Mach flight vehicles is depicted in figure 1. Current operational hydrocarbon fuels offer only a half MJ/kg (several hundred Btu/lb) heat-sink capability. One approach being considered is to use an endothermic fuel. A typical scheme is represented by the dehydrogenation of methylcyclohexane (fig. 2), resulting in the formation of toluene and hydrogen and offering a total heat sink of approximately 4.4 MJ/kg (1900 Btu/lb). Actually, the Air Force sponsored much research in this area in the 1960's and is moving ahead with this technology opportunity once again. Obviously, a number of other candidate fuels exists, as shown in table II, including cryogenic hydrogen. Various system safety issues, including fire safety, will need to be addressed as progress towards the actual system application of these fuels is made.

#### AIRCRAFT FUEL SYSTEM EXPLOSION PROTECTION

In aircraft fuel systems, by and large, through the application of appropriate fire/explosion prevention measures, normal operation mishap possibilities have been adequately minimized. In the case of military systems, the

combat scenario has necessitated incorporation of additional fire and explosion protection measures. Current practice includes the use of reticulated plastic foam explosion suppressants (i.e., polyester and polyether polyurethane foams); bromotrifluoromethane (CF<sub>3</sub>Br, Halon 1301) inerting on a part-time basis; and liquid nitrogen inerting for full-time protection. Major current R&D effort is directed towards the development of an onboard inert gas generation system (OBIGGS) with first likely application to be on the C-17 aircraft currently under development for the Air Force by McDonnell-Douglas. Research is continuing by the Air Force for the development of more efficient air separation membranes for OBIGGS to enable application to fighter aircraft, as well as to reduce subsystem weight penalty for the larger aircraft. Actually, the current OBIGGS technology is very competitive with other state-of-the-art, full-time fuel tank explosion protection systems, and compared to LN<sub>2</sub>, it offers considerable advantage in worldwide logistical independence. References 102 to 111 provide additional information on the above approaches as well as on some of the electrostatic hazard problems encountered operationally with reticulated foams. With respect to the latter, industry efforts are underway to develop a more conductive reticulated baffle foam, with an acceptable product likely to be available very soon.

#### HYDRAULIC FLUIDS

In the area of aircraft hydraulic systems, the preponderance of fire problems has been experienced with military aircraft, which for years employed a petroleum-base hydraulic fluid (MIL-H-5606). By comparison, civil experience with the more fire-resistant phosphate-ester-type hydraulic fluid has been very favorable. Because of performance and materials compatibility reasons, the phosphate-ester-type fluid is not acceptable for military aircraft. Recently, military aircraft have been converting to MIL-H-83282, a synthetic hydrocarbon with a much higher flash point temperature, which is totally acceptable in existing operational aircraft systems. Since the mid-1970's, technology effort has also been focusing on the development of a nonflammable hydraulic fluid for future advanced military aircraft applications. This technology (refs. 112 to 119) has progressed to the selection of a CTFE (chlorotrifluoroethylene) fluid for use in a 55-MPa (8000-psi) system, and the fluid is scheduled for demonstration/validation in the near future. Table III summarizes selected properties of current and candidate nonflammable hydraulic fluids as well as the fire properties goals that were established in 1975 for the screening of candidate materials.

#### PROPULSION INSTALLATIONS

Propulsion installations have inherently been treated as high fire-threat areas; consequently, a well established fire protection engineering capability exists. Much of this capability evolved from the earlier days when full-scale engine/nacelle fire tests were conducted by the CAA in Indianapolis, Indiana, and subsequently by the FAA at the Atlantic City, New Jersey test facilities. Testing was conducted in support of both military and civil applications. To my knowledge, the only ongoing testing of this type is at the FAA facility for the Air Force utilizing a surplus F-111 aircraft fuselage/TF30 engine as the test article. This testing is focusing on jet fuel ignition fire detection and fire extinguishing agent considerations under a broad range of air mass-flow ventilation rates and temperature conditions representative of today's

turbofan engine installations in military aircraft. At the same time, at the Aero Propulsion Laboratory, similar tests are being performed in an engine nacelle fire-test simulator for the purpose of establishing comparative fire protection performance trends. The engine nacelle simulator was developed a few years ago as a planned alternative to full-scale testing because of the high cost and future general nonavailability of actual advanced engines for conduct of potentially destructive fire testing.

With regard to engine compartment fire and overheat detection, modern aircraft are largely equipped with continuous-element, heat-sensitive-type systems (i.e., pneumatic and electrical resistance types). These systems provide line coverage and require 5 to 15 sec for response. Dual loop coverage has been incorporated in certain instances to reduce past false-warning problems. For advanced flight vehicles, detection systems will require high reliability, quick response, and the ability to discriminate more clearly between fire and overheat conditions. The latter will necessitate more emphasis on optical sensors (ultraviolet, infrared types) integrated with continuous element systems. It should be pointed out that very little R&D is currently in progress in this area. A few years ago, an advanced ultraviolet aircraft fire detection system was developed for the Air Force (ref. 120) and installed in an F-111 aircraft at the Sacramento Air Logistics Center, McClellan AFB, California, for flight test evaluation. The planned evaluation was successfully accomplished; the system still remains installed and is performing satisfactorily.

Extinguishment of engine compartment fires is presently accomplished by means of fixed systems employing halogenated hydrocarbon agents. No major technological advancement has been made in this area in recent years. Halogenated fire extinguishing agents that were researched mainly in the 1940's to early 1960's and used on aircraft are indicated in table IV. Present day preference is for Halons 1301 and 1211, which offer the best combination of performance, low toxicity hazard, and reasonable availability/cost. The Boeing Company has recently completed a favorable investigation of the fire extinguishing performance potential offered by various nitrogen-enriched air (NEA) mixtures as an ancillary function of OBIGGS (ref. 102). Use of NEA for continuous purging of electronic cabinets and fire control onboard spacecraft would also appear to merit consideration.

#### AIRCRAFT POST-CRASH/INTERIOR CABIN FIRES

The aircraft survivable impact, post-crash fire scenario and the closely intertwined interior cabin fire problem have received considerable attention in recent years, both on a national and international basis (refs. 121 to 127). The post-crash fire scenario is a difficult one to contend with. The environment rapidly deteriorates from thermal, chemical, and visibility viewpoints. Toxic and irritant products generated have rapid debilitating effects. The traumatic situation makes breath-holding essentially impossible and pain thresholds are rapidly reached. The cabin can become a totally lethal environment. This also is true of ramp and in-flight fires if the fire source is large enough. Time, measured in seconds, is a key factor in survival.

Approaches for enhancing the crash worthiness of the aircraft include the use of crash-resistant fuel tanks where feasible, protection of fuel system components, development of fire-safe fuels, increasing the fire worthiness of

interior materials, improving interior emergency lighting, and providing more fire-resistant escape slides. The bulk of the activity in these areas has been pursued by the FAA and NASA. Sarkos (ref. 127) provides an excellent summary of efforts directed toward improving aircraft interior safety. The work in the latter area obviously should have direct applicability to the spacecraft fire safety problem, particularly where use of a normal-air habitable atmosphere is planned.

With regard to extinguishment of fires within aircraft interior compartment areas, first-aid fire extinguishers employing Halon 1211 ( $\text{CF}_2\text{BrCl}$ ) fire extinguishant are now being utilized by both military and civilian aircraft because of its suitability, to some degree, for all classes of combustibles, excluding metal fires. Selected higher hazard areas, such as galleys and refuse bins within lavatories, in certain cases have been equipped with fixed fire extinguishing systems usually of the Halon 1301 ( $\text{CF}_3\text{Br}$ ) type. Use of Halon fire extinguishants in oxygen-enriched and hyperbaric chambers depends in part on the extent of oxygen enrichment and should be carefully and independently assessed for each application. Depending on the rapidity of fire extinguishment action, different degrees of agent pyrolysis can be experienced. Consequently, in assessing the overall toxicity hazard, consideration must be given to both the byproducts formed by the fire and the extinguishant utilized. Removal of potentially toxic byproducts from the spacecraft atmosphere after effecting fire control will also require special attention in order to resume safe, normal operations.

#### CONCLUDING REMARKS

In summary, during the past 15 years, very significant progress has been made toward enhancing aircraft fire safety in both normal and hostile (combat) operational environments. I have attempted to touch on most of the major aspects of the aircraft fire safety problem and necessarily have had to limit the depth of coverage. The technology of aircraft fire protection, although not directly applicable in all cases to the potential spacecraft fire scenarios, nevertheless does provide a solid foundation to build upon. This is particularly true of the extensive research and testing pertaining to aircraft interiors' fire safety and to OBIGGS, both of which are still active areas of investigation.

TABLE I. - TYPICAL PROPERTIES OF MILITARY TURBINE ENGINE FUELS

	JP-4	JP-5	JP-8	JP-8X
Density, kg/m <sup>3</sup>	764	818	800	872
Boiling range, °C	65 to 250	190 to 260	175 to 270	175 to 270
Heat of combustion				
MJ/kg	43.5	42.8	43.0	42.6
Btu/lb	18 700	18 400	18 500	18 300
Btu/gal	120 000	126 000	124 000	135 000
Hydrogen content, wt %	14.4	13.7	13.8	13.3
Viscosity, cS, at				
-40 °C	2.8	11.0	10.0	14.0
-18 °C	1.9	4.2	3.8	4.4
4.4 °C	1.4	2.2	2.0	2.4
Flash point, °C	-30	60	53	53
Freezing point, °C	-59	-46	-50	-62

TABLE II. - HIGH-MACH PROPULSION FUEL CANDIDATES

	Methyl- cyclohexane	Decalin <sup>a</sup>	Methane	Ethane	Hydrogen
Density, kg/m <sup>3</sup> , at 16 °C	772	882	b424	b574	b70.7
Boiling point, °C	101	194/185	-161	-89	-252
Freezing point, °C	-126	-43/-31	-183	-172	-259
Base fuel					
Heat of combustion, MJ/kg	43.4	42.6	50.0	47.5	120.0
Heat of combustion, Btu/lb	18 650	18 320	21 500	20 420	51 600
Heat of combustion, Btu/gal	120 106	134 926	76 110	97 811	30 444
Products (100 percent conversion)					
Heat of combustion, MJ/kg	45.4	44.6	-----	52.1	-----
Heat of combustion, Btu/lb	19 530	19 160	-----	22 384	-----
Heat of combustion, Btu/gal	125 773	141 017	-----	107 219	-----
Heat sink, MJ/kg (100 percent conversion, 15 to 725 °C)	4.43	3.91	c2.69	c6.98	c14.7
Ratio of heat sink/heat of combustion	0.098	0.088	0.054	0.13	0.122

<sup>a</sup>Double values for decalin boiling and freezing points are for the cis and trans varieties, respectively.

<sup>b</sup>At boiling point.

<sup>c</sup>From boiling point to 725 °C.

TABLE III. - TEST PROPERTIES OF AIRCRAFT HYDRAULIC FLUIDS

Test parameter	Goal	MIL-H-5606	MIL-H-83282	Phosphate esters Skydrol 500B	Navy MS-6 silicone	Halo-carbon A-08	Dupont E-6.5	Brayco 814Z
Heat of combustion, MJ/kg	<11.6	42.1	41.2	29.8	22.7	5.56	4.14	0
Autoignition temperature, °C	>700	224	340	510	410	640	670	920
Hot manifold ignition Stream, °C	>930	430	315	780	480	930	>930	>930
Spray, °C	>930	760	700	820	540	>930	>930	>930
Atomized spray, open flame	Nonreactive	Sustains	Sustains	Extinguishes	Extinguishes	Nonreactive	Nonreactive	Nonreactive
Flash point, °C	N/A	100	224	180	280	-----	-----	-----

TABLE IV. - PROPERTIES OF HALON FIRE EXTINGUISHANTS

Formula	Halon number	Molecular weight	Freezing point, °C	Boiling point, °C	Density (liquid) at 21 °C, kg/m <sup>3</sup>	Storage stability, °C
CCl <sub>4</sub>	104	154	-13	77	1580	200
CH <sub>3</sub> Br	1001	95	-93	3	1730	-----
CH <sub>2</sub> BrCl	1011	129	-87	67	1930	120
CF <sub>2</sub> Br <sub>2</sub>	1202	210	-142	23	2280	180
CF <sub>3</sub> Br	1301	149	-174	-58	1570	>260
CF <sub>2</sub> BrCF <sub>2</sub> Br	2402	260	-111	47	2160	>260
CF <sub>2</sub> BrCl	1211	165	-161	-4	1830	200

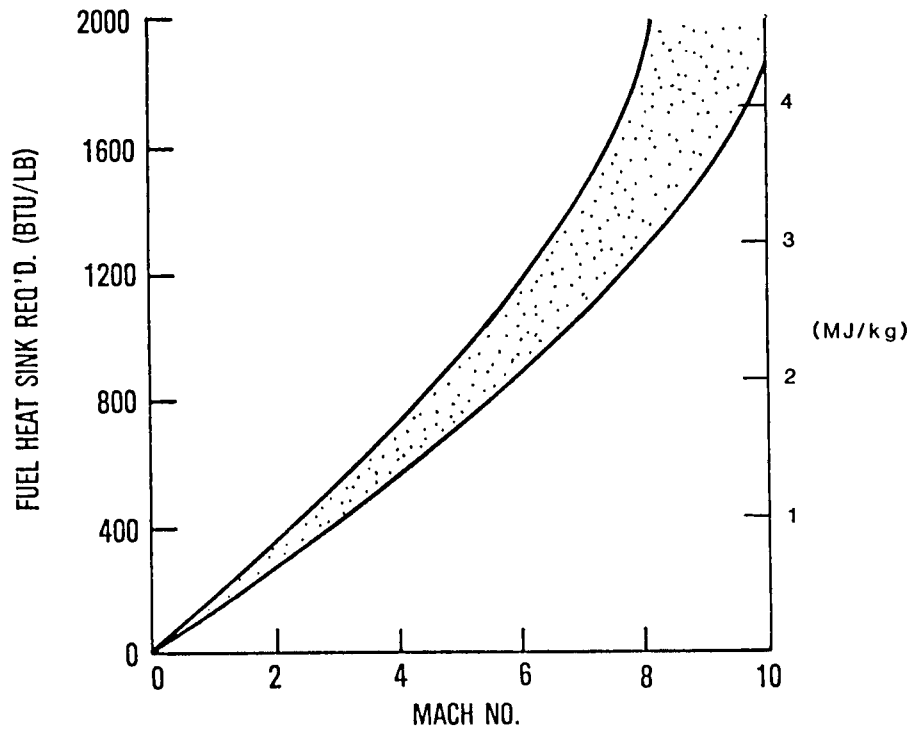

Figure 1. - Typical fuel heat-sink requirement trend for high-Mach-number flight vehicles.

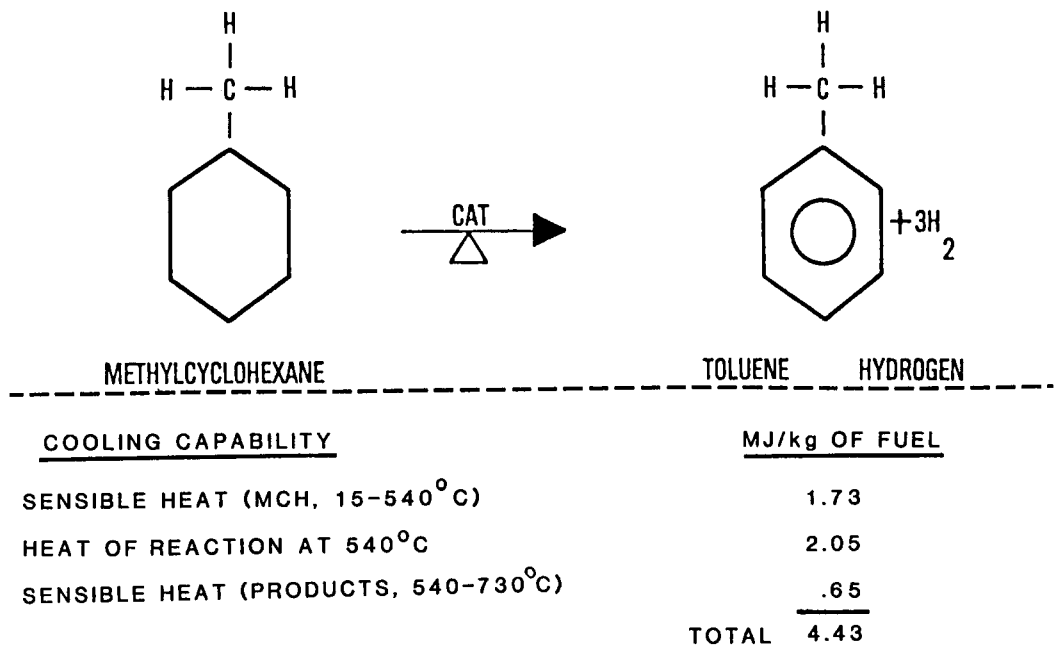

Figure 2. - Endothermic dehydrogenation of methylcyclohexane (MCH).



## SPACE STATION INTERNAL ENVIRONMENTAL AND SAFETY CONCERNS

Matthew B. Cole  
NASA Lyndon B. Johnson Space Center

Space stations of the future will have many areas of concern involving safety. The nature of the operation of space stations will require that safety be of paramount importance to ensure crew survivability and mission continuity. Space stations will be designed as outposts on a new frontier: space. This frontier is hazardous and unforgiving. Mistakes in the operation of a space station or the prediction of conditions and hazard scenarios could have very serious consequences. Space stations will have long lifetimes, limited capability for rescue, extremely hazardous operating environments, crewmembers who will not be astronauts, and a complex set of operating procedures. The possibility for mishaps to occur is very real.

## SPACE STATION MODULES

Space stations will require some typical kinds of occupancies within their individual modules to be functional. The first basic kind of module that will be found is a habitation module. This module will contain the living space for the crew. The crewmembers will prepare and eat their meals in the habitation module. Facilities for personal hygiene and recreation and exercise will probably be found in the habitation module. Space to store the personal belongings of the crew and supplies necessary for dining will be found here.

A second kind of module occupancy that will be typically found in space stations is one or more laboratory modules. The purpose of space stations, the advancement of science and technology, will require extensive facilities to perform experiments of many types in the microgravity of space. As with laboratory facilities on earth, there will be hazardous processes and chemicals used in laboratories on space stations, and the probability for mishaps to occur is appreciable. Laboratories will require careful design and control to achieve safe operations.

A third kind of module that will likely be found on future space stations is a supply, or logistics, module. This module will be used to store consumables required for the operation of a space station. As with some storage facilities on earth, materials that are incompatible with each other may be stored side by side. The strict configuration control requirements for spacecraft will provide controls and safeguards for these types of storage, but the existence of incompatible materials near one another increases the probability of a mishap.

Figure 1 indicates a possible arrangement of the NASA Space Station modules. The modules in this figure are connected together by nodes and tunnels. Two of the modules are connected together in a circular arrangement, with the other two attached to this circular track.

Figure 2 is a possible arrangement of the inside cross section of one of the modules. Maximum advantage of space is used in this arrangement. The insides of the module next to the outer walls are used for the location of

avionics, equipment, and storage areas. The habitable spaces are contained within a square cross section inside the module.

#### MODULE HAZARDS

Safety concerns in the internal environment fall into several broad categories. Radiation is more intense in the environment of space, in both its ionizing and nonionizing forms. Ionizing radiation will take the form of gamma rays, x-rays, and high-energy charged particles. Nonionizing radiation that will be found in the internal environment will probably consist of ultraviolet rays from viewing ports in the module hulls and beams from the experimental use of lasers in the laboratory modules.

Toxic substances will be used in the operating systems of the Space Station and in the laboratory experiments. The threat of an inadvertent release of a toxic gas, liquid, or solid will always be present. The effects of such a leak in a space station will be compounded by the nature of the Space Station's location and design. The Space Station will need real-time detection and analysis systems to detect the accidental release of toxic substances. Real-time analysis is needed to allow the crew to decide on a course of action to neutralize the leak.

Emergency decontamination apparatus will be needed for personnel working in laboratory modules. Emergency containment kits are available today for use in laboratories; this same type of approach could be adapted for use in a microgravity environment. Self-contained emergency shower devices and eyewash devices could also be developed for use on Space Station. Apparatus specifically tailored for decontamination of personnel exposed to particular substances could be provided on an as-needed basis.

Toxic chemicals in the internal atmosphere are not the only crew threat. Biological organisms and particulate matter in the internal atmosphere present health threats to the crew. In the microgravity of space, large particulate matter does not automatically fall to the floor of a compartment. Particulate matter of any size will follow the flow of the mechanical ventilation in a module. Particulates with diameters larger than 150  $\mu\text{m}$  present an irritation problem to the crewmembers. Biological organisms will always be present. If they find internal atmospheric conditions suitable for growth, they can reach populations that present health threats to the crew. Control of the internal atmospheric humidity, temperature, food storage and disposal, and sterilization and filtering of the internal atmosphere will reduce the probability of illness due to biological organisms.

Crew injuries and illnesses are particularly serious matters due to the remoteness of the Space Station. Crew expertise and training to treat injuries and illnesses will be a necessity. Medical supplies will be necessary to handle anticipated problems.

Finally, there is the threat of fire or explosion. Fire or explosion will result in additional threats due to their aftereffects. Fire or explosion will do damage to the spacecraft system in which it occurs. Crew response is required to control the threat; this presents the threat of injury to the crew. After the fire or explosion threat has been controlled, there is the problem of internal atmospheric contaminants. Fire is perhaps one of the most credible

threats, the most likely to occur. There are many aspects to this phenomenon which must be incorporated into the design of Space Station.

### HISTORIC SPACECRAFT FIRE PROTECTION

There have been a variety of fire protection methodologies applied to U.S. manned spacecraft since the Mercury program. A clear and distinct pattern has not emerged.

The Mercury and Gemini spacecraft were very small in relation to the Space Shuttle Orbiter of today. The Mercury capsule contained one person; the Gemini capsule contained two persons. Fire detection on these spacecraft was accomplished via the sensory perception of the crew. There were no systems designed specifically for fire suppression, but the food rehydration gun on these spacecraft conceivably could have been used for this purpose had it been necessary.

The Apollo spacecraft was considerably larger than Mercury and Gemini. The Apollo Command and Service Module (CSM) accommodated a crew of three. After the ascent phase of the mission, the acceleration couches to which the astronauts were strapped could be folded up and out of the way. During the lunar landing missions the Apollo CSM was accompanied by the Lunar Module (LM). The LM could hold two persons.

Fire detection on the Apollo CSM and LM was again left to the sensory perception of the crew. There were no specific smoke detection schemes, although the possibility of using a condensation nuclei fire detection system was considered (ref. 128).

Fire suppression on the Apollo spacecraft was provided via several means. In the CSM, the primary means of fire suppression was a portable foam fire extinguisher. The food rehydration gun also had a flow-control spray nozzle and was utilized as a backup fire suppression system. In the Apollo Lunar Module, the fire suppression system was the food rehydration gun.

The use of strict materials flammability control requirements came into being during the Apollo era. The effects of oxygen-enriched atmospheres on the flammability of materials were then more fully understood.

The Skylab program was conducted in the early 1970's as an orbiting workshop. Skylab consisted of an upper stage of a Saturn booster rocket that had been converted for manned use in space. It had a docking adapter to which the Apollo CSM was berthed. Skylab was the first U.S. manned spacecraft that was too large to rely on the sensory perception of the crew for fire detection. Fire detection was accomplished by the use of line-of-sight ultraviolet-type fire detectors. Fire suppression on Skylab consisted of portable foam fire extinguishers. A schematic diagram of one of these portable fire extinguishers is shown in figure 3. These fire extinguishers had a removable nozzle so that the foam could be discharged through built-in openings in the avionics panels in the event of a fire in the avionics. Figure 4 (ref. 129) shows the locations of the portable fire extinguishers in Skylab and the estimated crew translation times.

The Space Shuttle Orbiter in use today can accommodate a crew of eight persons. The crew cabin consists of two areas of habitable space: the flight deck and the middeck.

Fire detection on the Space Shuttle Orbiter is provided by the use of ionization smoke detectors located in the crew cabin and the avionics bays. Figure 5 (ref. 130) shows the locations of these smoke detectors. These smoke detectors have a self-contained fan to draw cabin air into them for sensing purposes.

The Space Shuttle Orbiter uses portable and fixed Halon 1301 systems for fire suppression. The agent storage containers for both fixed and portable systems are similar, the difference being that the fixed systems are remotely discharged from a control panel on the flight deck. The fixed fire suppression systems on the Space Shuttle Orbiter are located in the three forward avionics bays. Figure 6 (ref. 130) shows the location of the portable fire extinguishers in the crew cabin. As was the case in Skylab, the nozzle on the portable fire extinguishers is compatible with fire ports (openings) in the panels. The agent nozzle can then be inserted into an opening in the instrument panels and the agent discharged to extinguish fire behind the instrument panels. The portable fire extinguishers can also be discharged through the openings in the avionics bays shown in figure 7 (ref. 130) in case the fixed fire suppression systems in the avionics bays fail.

#### MICROGRAVITY FIRE BEHAVIOR

The history of fire protection on manned U.S. spacecraft indicates that there has been no clear pattern of agreement on what is ideal. To preface a discussion of what is ideal for fire detection and suppression in a microgravity environment, it is necessary that the differences in fire behavior between normal and microgravity be discussed.

Combustion in a normal (one-g) environment is driven by convection due to gravity-induced buoyancy. Hot smoke is driven up and away from a diffusion flame. In microgravity, there are minimal buoyancy forces; products of combustion are not forced away from the diffusion flame (ref. 131).

Under calm conditions in a microgravity environment, the spread of the flame front is slower than in normal gravity. Calm conditions are seldom encountered in the usual crew space in a spacecraft, however. Due to other life support considerations and the need to provide cooling air for electronic equipment, forced airflow is provided throughout the habitable space. This forced airflow will increase and define the direction of flame spread in a microgravity environment. Velocities of airflow exceeding some threshold value may even help prevent the occurrence of diffusion flames.

#### SPACE STATION MATERIALS ACCEPTANCE

Unlike facilities on Earth, control of all of the materials that are used for construction and that are placed in a manned spacecraft is a normal procedure. Each material in a manned spacecraft must meet current National Aeronautics and Space Administration (NASA) flammability criteria (ref. 4), or its

use must be evaluated and judged to be acceptable by a controlling group of program managers.

Materials flammability control in Space Station will probably be accomplished by using standards similar to the current standard used for the Space Shuttle Orbiter. Although the criteria for materials flammability acceptance are too lengthy to discuss here, there are four basic tenets that apply. Materials are categorized by their use and placement in the spacecraft. More stringent requirements are levied on materials that are placed in the same environment as the crew. Materials are tested for flammability characteristics in the same atmosphere(s) which they will encounter in the spacecraft. Finally, materials are tested in their end-item configuration.

Some essential materials are not able to pass the current NASA flammability criteria. These materials include some clothing, various personal hygiene articles, paper, and food. Avoiding large concentrations of these materials through good housekeeping practices is one way of lowering the risk of fire in the spacecraft.

## SPACECRAFT FIRE DETECTORS

### Types

Fire detection on the Space Station could be accomplished in several ways. Ionization-type smoke detectors, such as are used on the Space Shuttle Orbiter, could be used for this purpose. These detectors react best to particles in the 0.1 to 0.3  $\mu\text{m}$  diameter range (ref. 132). This size range of particles is produced by flaming combustion. Ionization-type smoke detectors tend not to react well to particles with diameters larger than 0.3  $\mu\text{m}$ .

Photoelectric-type smoke detectors are another possibility. These detectors react best to particles larger than 0.3  $\mu\text{m}$  (ref. 132).

A method of smoke detection using a condensation nuclei counter such as was considered during the Apollo program would be feasible on Space Station. The condensation-nuclei fire detector (CNFD) uses a Wilson Cloud Chamber in its operation. Smoke-laden air is drawn into the CNFD by a sampling pump and is passed through a device with water to provide close to 100 percent relative humidity in the air sample. The pressure in the chamber in which the sample is located is then suddenly reduced by a vacuum pump. The moisture in the then supersaturated air will condense on nuclei present in the air sample, such as particulates from smoke. In tests conducted by Bricker (ref. 133), the CNFD was found to be faster than either ionization or photoelectric smoke detectors. The CNFD reacted well to both visible flames and to smoke from smoldering plastics after the plastics smoke had been passed through a device to further pyrolyze it into smaller particles.

The CNFD type of detection system is not immediately ready for use in a microgravity environment. The CNFD utilizes water in its operating system to humidify the air samples. This makes this detection method somewhat more difficult to use in a microgravity environment than other methods. There is also more maintenance involved in the CNFD operating system.

The internal atmosphere in Space Station will be kept as free from particulates as possible for various health and operating reasons. The concentration of particulates in the internal atmosphere will be monitored by the use of a particle counter. Since both smoldering and visible combustion produce high concentrations of particles, it may also be feasible in the Space Station to use a particle counting system for a smoke detection method.

Commercially available optical-type particle counters today can measure particles with diameters as small as 0.3  $\mu\text{m}$ , much the same as photoelectric smoke detectors. Commercially available condensation-nuclei counters can measure particles as small as 0.01  $\mu\text{m}$ . The condensation-nuclei particle counters use alcohol as their condensation fluid, however, so their use in a manned spacecraft presents a threat in itself.

With the threat of fire from a flammable liquid that may be used in a Space Station laboratory, the use of ultraviolet or infrared fire detectors must be considered. Both types of detectors are line of sight devices; that is, there must be a clear path between the fire and the detector. They both detect electromagnetic emissions from flames.

Ultraviolet fire detectors can be adversely affected by extraneous emissions of electromagnetic radiation close to the ultraviolet portion of the spectrum. These emissions can include x-rays and microwaves. Infrared fire detectors can be affected by heat-producing devices within a space station. Ovens with high-temperature heating elements and viewing ports may cause infrared fire detectors to alarm.

In line with previously mentioned safety concerns regarding chemical contamination, a real-time infrared atmospheric analysis device is a possibility for fire detection. This type of device would detect gases from combustion such as carbon monoxide, hydrogen fluoride, or hydrogen cyanide.

### Detector Systems

Any detection scheme will do no good if it is not designed to be in the path of smoke transport from a fire. The lack of natural convection in the microgravity of space makes the location of the detector a critical factor in Space Station. A possible approach is to locate the smoke detection devices in the environmental control and life support system (ECLSS) air circulation ducts. Smoke or particulates generated by combustion would be carried by the forced airflow through a duct to the smoke detector. Care must be exercised in this arrangement to have smoke detection devices located so as to be able to easily locate the source of an alarm in ducts that are manifolded together. Manifolded ducts will require more detectors.

After the smoke detection method has been chosen for Space Station, the decision as to how its input/output operation will be configured must be made. The annunciation of the alarm must get the critical information to the crew as quickly as possible. This information should include the fact that a detector has gone into an alarm condition, the location of the actuated detector, and the spread of the fire or its products. The actuation of a smoke detector should be indicated by both audible and visual means in Space Station. Information concerning the alarm should be available via commands to an onboard computer system. Visible means should be provided within an individual module to easily locate any smoke detector that is in an alarm condition.

All fire detection devices respond to some fire signature. These include visible and invisible particles, combustion gases, infrared and ultraviolet spectra, heat, and pressure increase. Many of these signatures are also produced by controlled phenomena, however, making the task of detecting hazardous uncontrolled fire more difficult and subjecting fire detection systems to false or inadvertent alarms. The goal of a fire detection system is to indicate with a high degree of confidence that a fire has occurred. False alarms must be minimized to prevent loss of crew productivity and alertness. The goal can thus be achieved by choosing good initial detection thresholds for fire signatures and by having the capability to adjust the thresholds as operating conditions and experience indicate. Multiple, independent detection techniques are also needed to independently confirm the existence of hazardous fire conditions.

## SPACE STATION FIRE SUPPRESSION

Fire suppression on Space Station is also not easily accomplished with just one method. To effectively cover credible fire scenarios, both fixed and portable fire suppression systems are needed on a space station.

### Gaseous Extinguishants

Gaseous agent fire suppression systems may be designed for either total flooding of a module or flooding of equipment or storage racks within a module. In either case, overpressurization of a module may occur and must be considered in the design of a fire suppression system. Module overpressure venting may be required during fire suppression agent discharge.

Gaseous fire suppression agents are very easy to handle in the microgravity of space. Bromotrifluoromethane, or Halon 1301 as it is commonly called, is one very effective gaseous extinguishing agent. It chemically inhibits chemical chain reactions in the combustion process to extinguish fire. Concentrations required for extinguishment of fires in electrical components are in the range of 7 percent by volume (ref. 134).

The use of Halon 1301 would require the least amount of agent storage space and pressure among the various feasible gaseous agents. Halon 1301 can be stored at <4 MPa (600 psi). The use of Halon 1301 would require no immediate cleanup of the area or surfaces in contact with the Halon or fire.

Disadvantages of Halon 1301 include the toxicity and corrosiveness of its decomposition products and of the agent itself. Halon 1301 may be incompatible with certain elements of the ECLSS on a space station. The most effective method of agent removal after discharge would be module venting.

Carbon dioxide is another gaseous fire suppression agent that may be feasible. It extinguishes combustion by displacement of oxygen in the atmosphere. Concentrations of carbon dioxide in total flooding system applications for electrical hazards on earth require carbon dioxide concentrations of 50 percent (ref. 135). This represents more mass that must be carried into orbit. Atmospheres of this composition are fatal to humans.

The use of carbon dioxide on a fire would also require no cleanup of the area contacted by the extinguishant. Carbon dioxide discharging onto equipment

would present a low-temperature thermal shock to the equipment being impinged upon. Storage pressures of carbon dioxide are higher than Halon 1301. Carbon dioxide is stored in gaseous and liquid form on earth at pressures up to 6 MPa (900 psi).

Removal of carbon dioxide after discharge would first require partial venting of the module. After the module has been partially vented, the residual carbon dioxide could be removed by the carbon dioxide separation capability of the ECLSS. Although small concentrations of carbon dioxide could be removed by the ECLSS, high concentrations occurring in a short time may be a potential problem with the carbon dioxide separation capability of the ECLSS.

The use of carbon dioxide to flood equipment racks appears to be more possible than a total flooding system for a module. The amount of module venting required to prevent overpressurization would be less. The impact to the ECLSS would also not be as significant.

Nitrogen is another inerting gas that may be used as a fire suppression agent. It has the same basic extinguishing characteristics and problems as carbon dioxide. If module venting upon discharge of the nitrogen is used to prevent overpressure conditions, the concentrations required for fire suppression would be fatal to humans within the design discharge volume.

Removal of nitrogen after its discharge would again require partial venting of a module, with oxygen being added after the partial venting to restore the normal atmospheric composition.

Use of fixed gaseous fire suppression systems for flooding equipment and storage racks in a module would require a lower quantity of suppression agent than a total flooding system for a module. This method would also reduce the risk of asphyxiation to crewmembers, as it is not likely that persons would be present inside a storage or equipment rack.

There are also disadvantages to the flooding of equipment and storage racks with gaseous agents. An extensive agent piping network would be required. The location of the individual rack in which the fire had occurred must be known. If rack flooding is used, means must be developed to prevent the mixing and subsequent dilution of the gaseous suppression agent with module air from outside the rack. The forced airflow through the rack must be stopped and the rack must be sealed from the module prior to agent discharge. Sealing the racks prior to agent discharge would also help reduce the spread of products of combustion.

Portable fire extinguishers could be used within the habitable space for fire suppression. These portable fire extinguishers could use the same gaseous agents as the fixed fire suppression systems. Removal of the fire suppression agent after discharge from a portable extinguisher would be somewhat simpler due to the lesser quantities. Removal of Halon 1301 would still have to be accomplished by venting the module to vacuum.

Consideration must be given to the reaction force that would occur due to discharge of the agent from a portable fire extinguisher. The reaction force from a fire extinguisher using Halon 1301 would be less than that of an extinguisher using carbon dioxide or nitrogen because of the lower agent storage pressure.



Although use of each of the aforementioned gaseous fire suppression agents requires at least some venting of a module, operational procedures after the occurrence of a fire may also dictate that the module atmosphere be vented to vacuum due to the products of combustion alone.

Gaseous fire suppression agents are successful to varying degrees in extinguishing fire in ordinary cellulosic or solid nonmetallic materials. Halon 1301 is the most effective gaseous fire suppression agent of the ones mentioned for use on fires in ordinary combustible materials, but it requires higher concentrations and longer time in contact with the combustion area to be effective. Carbon dioxide and nitrogen are less effective than Halon 1301 for extinguishing fires in ordinary combustible materials. Fire extinguishers on earth using gaseous agents are designed mainly for use on flammable liquids and energized electrical equipment fires.

#### Water and Foam

Since gaseous fire suppression agents are not effective in the extinguishment of fires in ordinary combustible materials, the use of a backup fire-suppression system using water or water-based foam should be considered on Space Station. Such a system could take the form of either a portable extinguisher or a hose and flow control nozzle connected to the onboard water supply. A system using a foam agent would be effective on both flaming and surface combustion. Foam would adhere to the surface on which it was placed. Cleanup procedures would involve wiping the foam from the area of application.

The use of water in a fire suppression system would be feasible if a means to prevent the introduction of large amounts of free-floating water in a space station were developed. This could be done by having a sponge applicator on the end of the water hose or the use of a rigid containment box that could be placed over the fire area and into which the water would then be discharged.

#### Complete Venting

As a last resort, venting a module to the vacuum of space as a means of fire extinguishment could be used. The depressurization rate would be a consideration to prevent violent rupture of closed containers. Venting would also increase the rate of flame spread of the fire. The possibility exists that if the fire were near the outlet for venting a module, the flame would follow the venting gases and damage the venting out piping and valve(s). Repressurization of the affected module may not be possible after the venting operation.

#### FIRE SAFETY IN HYPERBARIC CHAMBERS

Space stations may have hyperbaric chambers for use in treating various types of decompression sickness that may occur during crew extravehicular activity (EVA). Capability to provide up to 600 kPa (6 atm) of pressure with varying percentages of oxygen, including some that are oxygen-enriched with respect to normal atmospheric composition, may be required from a medical standpoint. Fire detection and suppression systems specifically designed for an oxygen-enriched environment will have to be provided for a hyperbaric chamber on Space Station. Fire detection could be either smoke or flame

either smoke or flame detectors. Flame detectors of either the ultraviolet or infrared type would provide the fastest response.

Fire suppression in an oxygen-enriched environment is a more complicated matter than the choice of detection methods. Of great importance is the fact that the occupants of the chamber cannot easily leave the confines of the chamber. The fire suppression agent chosen must be nontoxic and minimize the production of toxic decomposition products. Halon 1301 has been tested for use in an oxygen-enriched environment by Kimzey (NASA Manned Spacecraft Center Internal Note, Oct. 1967). He concluded that Halon 1301 is not effective for extinguishing fire in pure oxygen atmospheres. Halon 1301 in other oxygen-enriched atmospheres must be carefully evaluated for effectiveness and toxicity due to decomposition byproducts and concentrations required for fire extinguishment.

The use of carbon dioxide for a fire-suppression agent would present an asphyxiation hazard to the chamber occupants. Nitrogen could be added without displacing the existing oxygen for fire-suppression purposes. Water would also be feasible for use as a fire-suppression agent in a hyperbaric chamber in a microgravity environment. A system such as this would utilize a dedicated water supply tank containing water at a pressure sufficiently higher than the hyperbaric chamber so that an effective spray pattern could be achieved from the discharge nozzles. The discharge nozzles would be designed for three-dimensional impingement. Water flow densities could be based on requirements for oxygen-enriched atmospheres at normal-gravity conditions. Cleanup and containment equipment and procedures would be necessary for a fire suppression system using water.

#### FIRE CONTROL PROCEDURES

After the fire detection and suppression systems have been designed and built and Space Station is operational, the problem of "what to do when fire occurs" becomes one for humans to solve. A Space Station crew will have to be thoroughly trained to cope with fire emergencies.

After a fire has been detected, adequate means must be provided to alert the crew that a fire is in progress. The crew must then be able to interpret signals from the fire detection system to locate the fire quickly. Upon locating the fire, the crew must have a good idea of what the fire involves and how much of a threat it appears to be. The crew must perform tasks such as donning emergency air breathing apparatus, shutting off airflow to the affected equipment, and disconnecting electrical power to the affected equipment if deemed appropriate. The method of extinguishment must be decided upon. Should a fixed or portable gaseous agent system be used? Perhaps a water-based system would be better. The agent must then be effectively applied. After the fire has been extinguished, the fire area and its effects must be cleaned up. Finally, normal operations must be restored.

The tasks required to completely handle a fire on earth are usually done by several different entities. In Space Station, the crew will have to handle all of the tasks involved; their lives will depend on it.

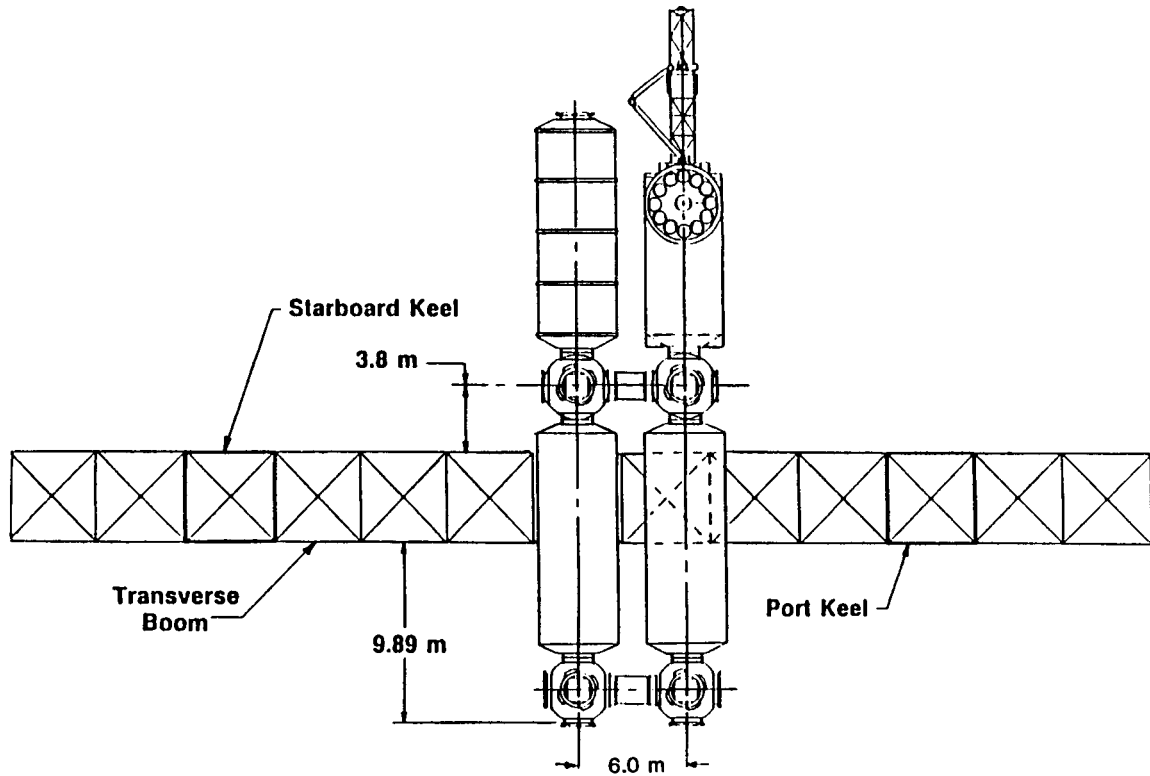

Figure 1. - Sketch of Space Station module arrangement.

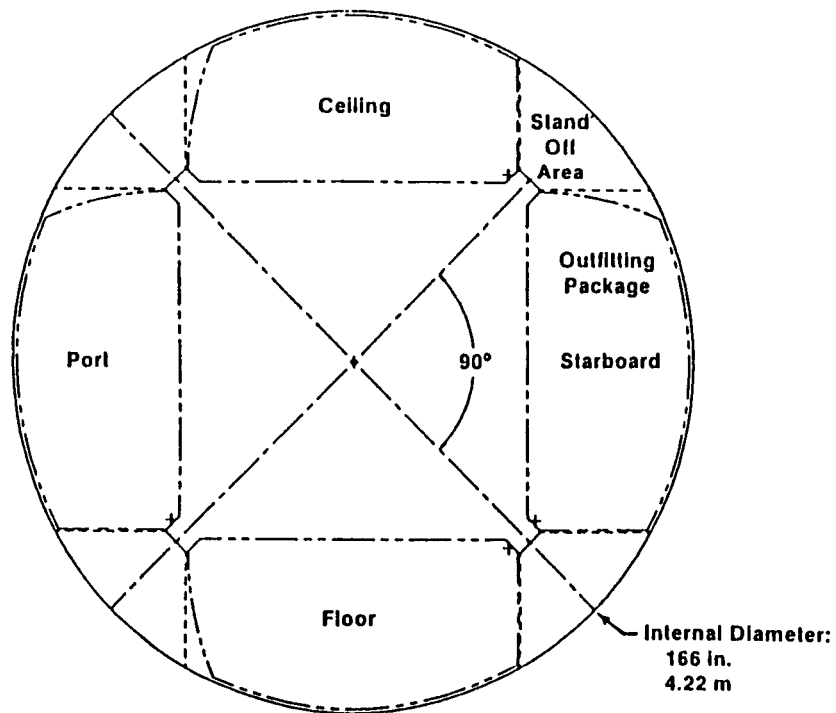

Figure 2. - Interior space in Space Station module.

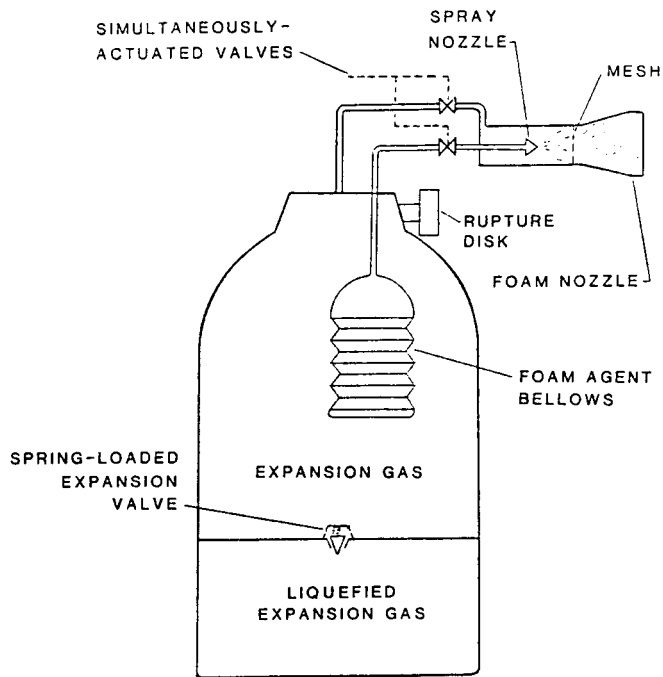

Figure 3. - Skylab fire extinguisher.

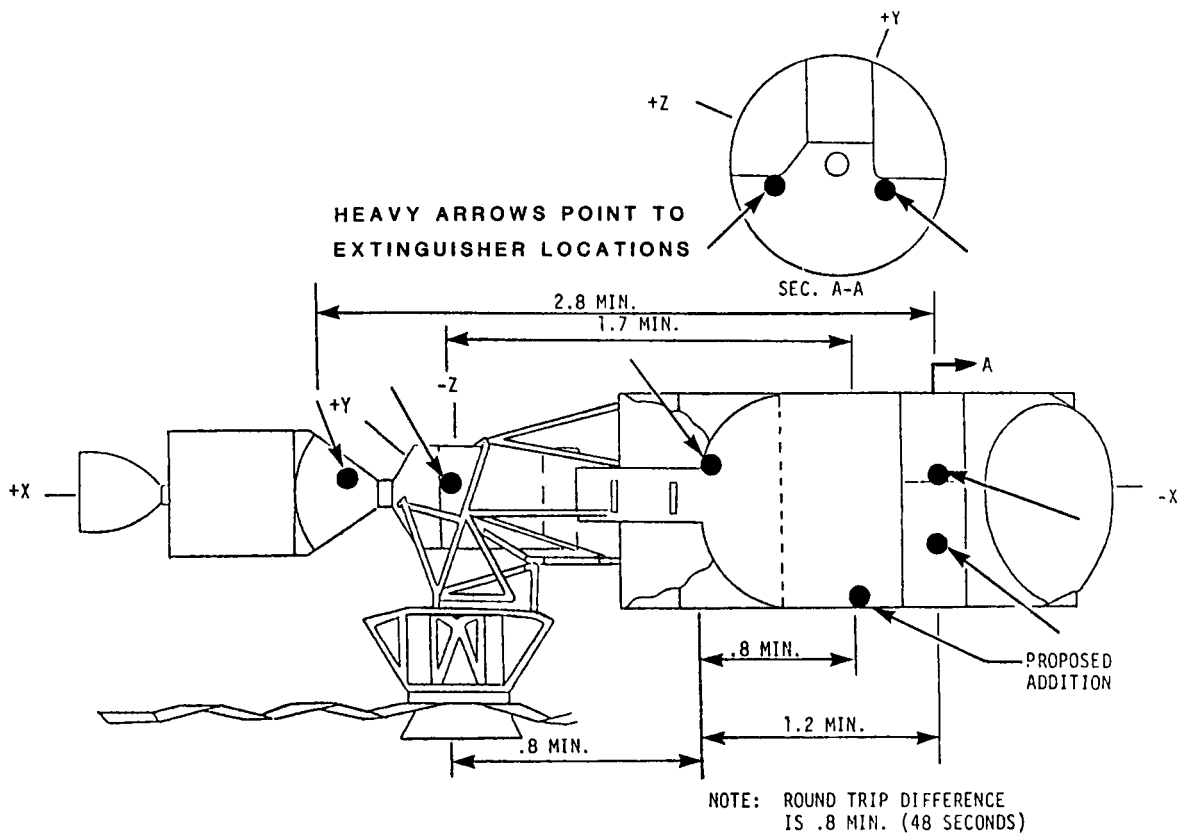

Figure 4. - Skylab fire extinguisher locations and estimated crew translation times.

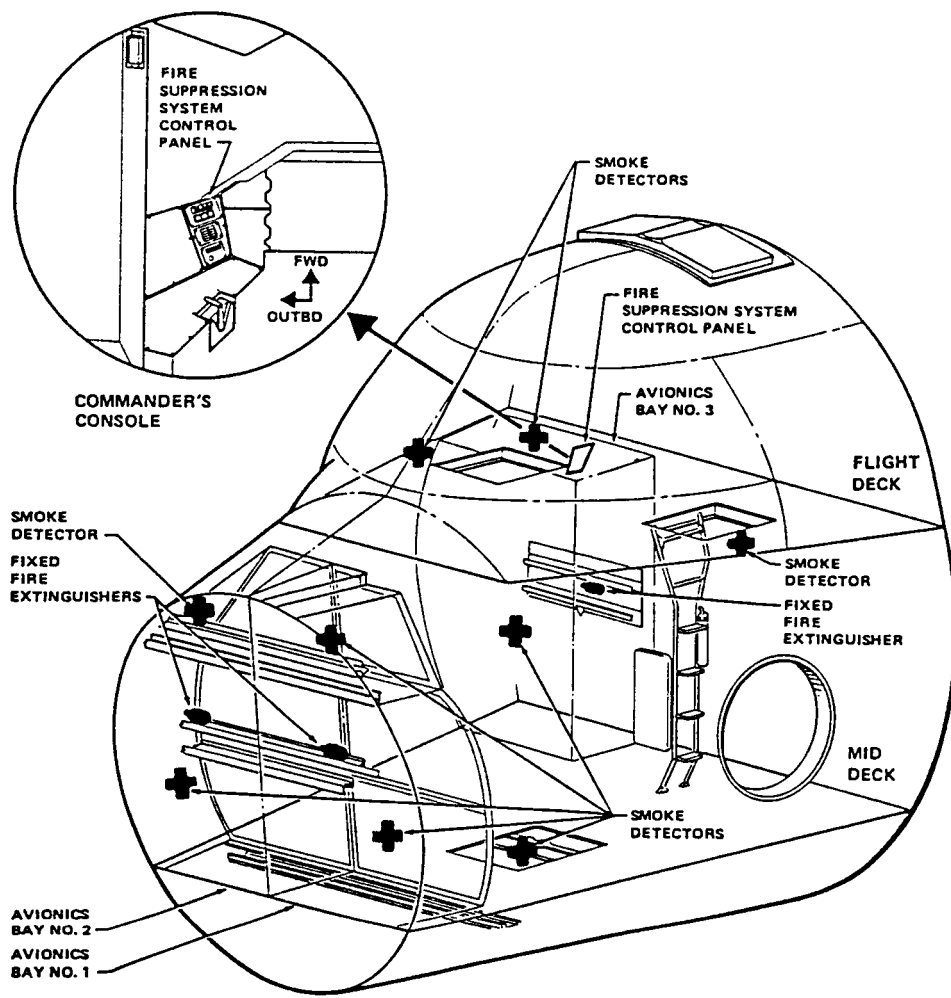

Figure 5. - Shuttle crew cabin and avionics bay fire protection.

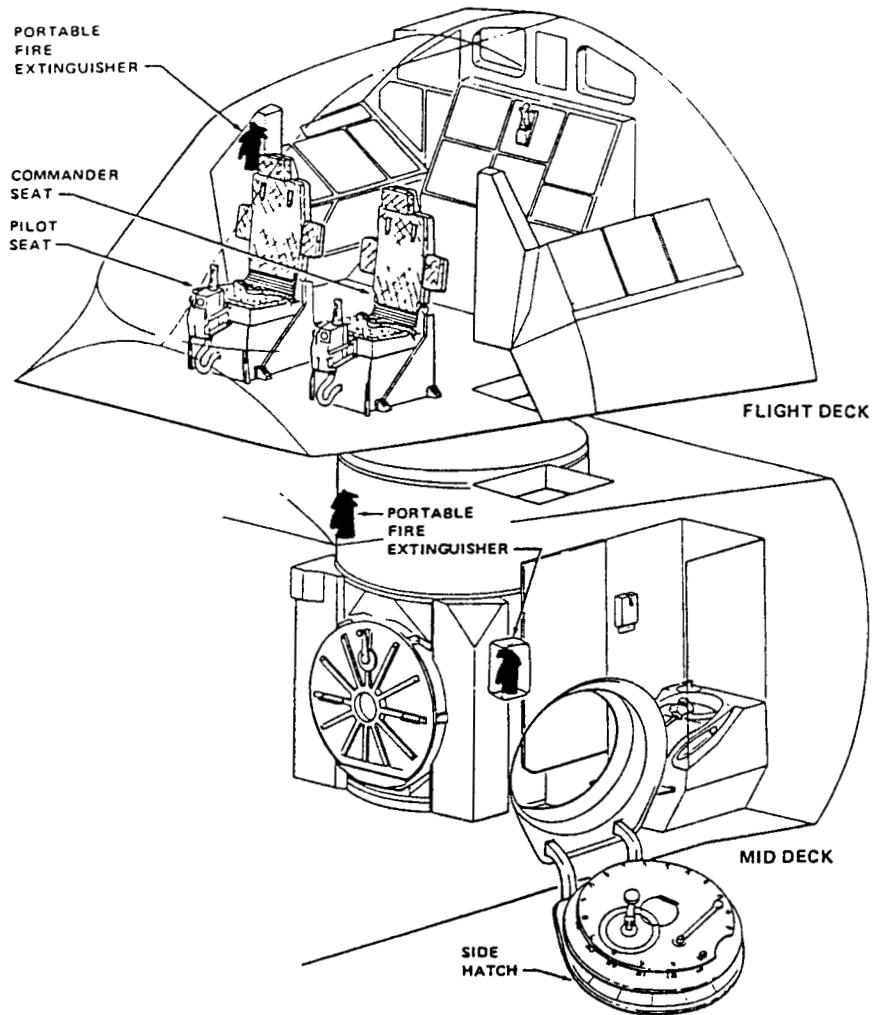
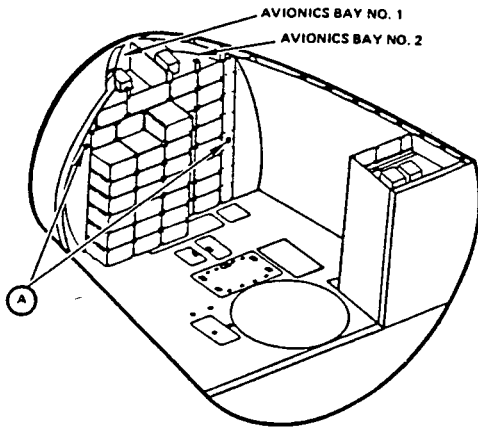

Figure 6. - Shuttle portable fire extinguishers.



**Note**

- FIRE PORTS PROVIDE ACCESS TO AVIONICS BAYS
- FIRE PORTS SIZED TO FIT PORTABLE FIRE EXTINGUISHER NOZZLE

Ⓐ FIRE PORT/GUIDE (TYPICAL)

**Avionics bays no. 1 and no. 2**

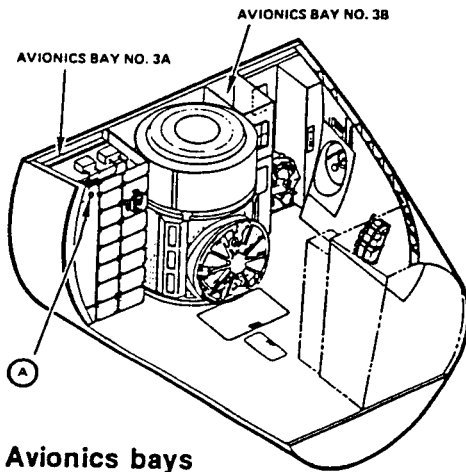

**Avionics bays no. 3A and no. 3B**

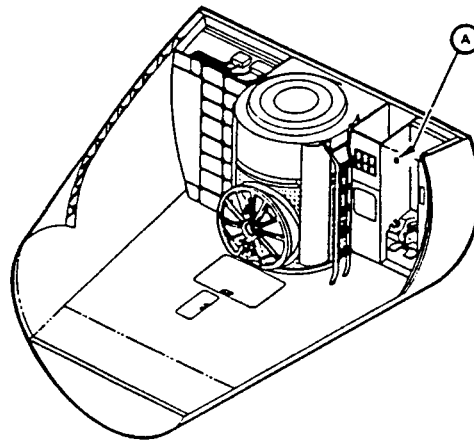

**Personal hygiene station**

**Figure 7. - Fire extinguisher ports in the Shuttle cabin.**

## MICROGRAVITY COMBUSTION FUNDAMENTALS

Kurt R. Sacksteder  
NASA Lewis Research Center

## INTRODUCTION

Systematic investigation of fundamental and applied combustion phenomena has been actively pursued for a number of decades. These efforts have usually been motivated by technological need in such diverse areas as ground and air transportation, electrical power production, and fire prevention. Naturally all such work has been done in the gravitational environment of the Earth, and an accounting of gravitational influence, while sometimes negligible, has usually been required. The growth of manned presence in the low-gravity environment of Earth orbit has provided a new technological need for directed combustion research related to spacecraft fire safety and at the same time has provided the means to pursue fundamental and applied combustion research in a low-gravity environment.

The earliest work in low-gravity combustion in the United States was related to the assessment of fire hazards in spacecraft (ref. 131). The flammability of certain test materials and the effectiveness of several candidate fire-extinguishing agents were evaluated in a quiescent, low-gravity environment. Based on the results of these quiescent chamber tests, material-screening test standards were established for spacecraft material selection (ref. 4). Other early work in low-gravity combustion was of more fundamental character, concerned more generally with using the low-gravity environment to simplify the physics of normal-gravity phenomena. Work of this sort was pursued in the area of premixed gases (refs. 136 to 139), unpremixed gases (refs. 140 to 143), solid-fuel flame spreading (refs. 144 to 146), droplet combustion (ref. 147), dispersed fuels (ref. 148), liquid pool fires (ref. 149), and smoldering (ref. 150).

Advances in the fluid mechanics of combustion have led us firmly to the conclusion that the equations describing energy, momentum, and mass balances, and chemical reaction rates are coupled. Changes in the body force, or gravitational terms in the equations describing fluid motion, result in changes to the coupled terms in the other system equations, which, in turn, again influence the fluid motion. Were the equations uncoupled, body force changes in the momentum balance would affect only the solution for fluid motion, and the other processes would be unaffected. Thus while low-gravity combustion research is a useful tool for understanding normal-gravity applications, care must be taken to avoid overgeneralizing the interpretations of low-gravity experimental results. Careful modeling work is an indispensable corollary effort to combustion experimentation, in order to correctly apply the results from one gravitational environment to another.

The application to spacecraft fire safety of our understanding of the physical and chemical processes that dominate combustion in low gravity is somewhat easier to achieve. Hazard analysis, and fire detection and intervention strategies can be derived more directly from low-gravity results. On the other hand, as a practical matter the screening of materials for use in spacecraft must be performed in ground-based, normal-gravity laboratories. Fundamental low-gravity combustion research is thus essential until a knowledge of



the fundamental processes involved is adequate to establish a well-understood relationship between low-gravity experiments and ground-based material screening tests.

What follows is a brief summary of some of the important physical processes involved in low-gravity combustion. While discussion is generally limited to the processes involved in the combustion of continuous, solid, non-metallic fuels, much of the reasoning presented can be applied to other fuel types and configurations. To the extent that the contributing mechanisms are known and understood in various fire scenarios, strategies can be developed to retard or prevent their progress. As low-gravity fire scenarios may require the consideration of some mechanisms normally considered as having secondary importance, some of these mechanisms may in this context be investigated in some detail for the first time. The value of such knowledge is accentuated in spacecraft fire planning because of the high cost of fire safety provisions and the even higher cost of failure.

## COMBUSTION MECHANISMS

The ignition and propagation of a fire is an interplay of rate processes including the generation of fuel vapor, one or more fuel-air mixing mechanisms, heat release from the chemical reaction, and the allocation of that heat to fuel generation, mixing, and dissipation.

### Fuel Generation

Fuel generation refers to the delivery of fuel to the vicinity of the flame zone, which is most often located in the gas phase. In the burning of solid or liquid fuels, the generation of fuel is generally some combination of chemical decomposition, or pyrolysis, and a phase change, such as evaporation, sublimation, or melting and evaporation. The phase change involves substantial expansion of the fuel and thereby influences the gas-phase flow field. Contributions to the flow field from fuel generation can be quasi-steady or precipitous and chaotic, and they are generally difficult to analyze.

Fuel generation also involves an energy exchange between the phases. Latent heats associated with phase changes and pyrolysis reactions act as net heat sinks with respect to the propagating flame. The feedback mechanisms of heat to the fuel surface generally include conduction, convection, and radiation, and they are complicated by the presence of soot in the gas phase and fuel charring on the surface. For purposes of fire extinguishment, the feedback loop of fuel generation and heat transfer to the surface may be the most important focus of intervention strategies.

### Mixing

The fuel-air mixing mechanisms in the propagation of flames are in each case a combination of bulk fluid motion acting in the presence of the diffusion of fuel vapors, oxygen, inert gases, and combustion products. Bulk fluid motion can be induced by several mechanisms, including buoyancy-driven (density gradient) flows, externally imposed, forced (pressure gradient) flows, and the flows associated with the pyrolysis/vaporization of the condensed-phase fuel (mass addition). The spread of the flame into regions containing fresh fuel and air and the flows driven by surface tension gradients of molten fuel can also contribute to the mixing process. In order for a flame to exist and

propagate, the aggregate mixing mechanisms must be effective to maintain a zone of flammable fuel-air mixture near enough to the existing flame to be continuously ignited.

Concentration-gradient diffusion of species on a molecular level is the most fundamental of the fuel-air mixing processes, wherein fuel vapors from the vicinity of the fuel surface gradually intermingle with the oxygen supply away from the surface. The process is relatively slow compared to the heat release rates required to sustain the fuel generation process. In the absence of additional mixing mechanisms, the presence of inert gases and gas-phase combustion products retard diffusive mixing of fuel and oxygen still further, such that the fuel vapors and oxygen must diffuse through a generally thickening layer of chemically inactive species to sustain adequate mixing rates. Thus systems dependent solely upon diffusion as the mixing process would generally fail to sustain a flame.

In normal-gravity fires large density gradients are created by rapid heat release in the flames. Under the influence of gravity these density gradients cause substantial natural-convection or buoyancy-driven flows, which often entirely overwhelm other fuel-air mixing processes. The coupling of buoyancy to heat release rates, other mixing mechanisms, and chemical reaction rates makes these flows difficult to analyze. As a result, progress in the understanding of normal-gravity fire spreading has been through the implementation of full-scale testing of a variety of configurations. Removal of the gravitational influence in the study of fires that might occur in a spacecraft exchanges this one mixing mechanism, which is difficult to analyze, for other, more subtle mechanisms, only one of which is molecular diffusion. The identification and evaluation of these subtleties have direct application in the analysis of low-gravity fires.

Ground-based, low-gravity experiments have shown how small fluid disturbances affect the perceived flammability of a material. An early approach to quiescent flame-spreading tests in drop towers was to reserve the limited low-gravity time (less than 6 sec) for flame propagation and to ignite the test samples before the drop release. Fluid motion generated by buoyancy during a normal-gravity ignition, although in decay after the drop release, often persists throughout the drop test and cannot be ignored. Samples ignited after the drop release in quiescent flame-spreading tests show reduced flame-spread rates up to moderate levels of oxygen content in the air when compared to the predrop ignition tests. While instructive from a procedural point of view, the comparison of these two methods also indicates the importance of fluid motion, which is less energetic than buoyancy-induced motion, to low-gravity flame spreading.

The influence of forced external flows on flame-spreading rates has been studied extensively in normal gravity. In the most general terms, an externally imposed flow, when acting as a mixing enhancement mechanism or as an aid to heat transfer to the fuel surface, increases flame propagation rates. As the strength of the forced flow increases, however, it can serve as a heat sink mechanism and retard flame spreading. Similarly, the forced-flow influence vanishes as its strength approaches that of the buoyancy-induced flow present in all such tests. Although a discussion of these observations is incomplete without including the convective heat transfer effect of the flow, the fuel-air mixing aspect of very low-speed (sub-buoyant) flows is not addressed at all in these experiments. Ventilation of spacecraft cabins for

life-support purposes provides such low-speed flows, and its potential impact on low-gravity flammability is a subject of current research activity.

The momentum associated with the pyrolysis/vaporization of fuel at the surface must be included as a mixing process in the analysis of fuels burning in quiescent low-gravity environments. The strength of this mechanism is a property of the fuel material and is related to the latent heat required to generate the fuel vapor and the behavior of the fuel surface during the fuel generation process. Low-gravity experiments in flame spreading have shown that this fluid motion acting together with diffusion can sustain propagating flames in the absence of other mixing mechanisms. The quiescent experiments conducted to date have shown that, for the simple paper samples examined, stable flames can be sustained only at higher oxygen concentrations than are required to burn the same material in normal gravity. Detailed modeling of the process has required the inclusion of the effects of a surface fuel "jet" in order to predict accurately the flame shapes observed in the experiments.

Other materials, having entirely different processes governing the release of gaseous fuel from the condensed-fuel surface, may exhibit a stronger influence of the fuel jet on the flame. Some burning plastic materials melt, then boil, at the surface. Experiments conducted at low gravity on the burning of nylon Velcro samples have shown precipitous release of fuel vapor from bubbles of molten plastic (ref. 146). This mechanism of fuel release and mixing randomly injects fuel vapors into the flame and renders nylon samples, mounted without a heat sink substrate, flammable in moderate oxygen concentrations at low gravity. The bursting of bubbles in molten fuels has also been shown to eject small particles of burning material from the surface. These particles might also serve as additional ignition sources for remote fuel locations. Other plastic samples such as slabs of polymethylmethacrylate (PMMA) form a char on the molten fuel surface that acts to inhibit the vaporization of fuel. Thus the surface behavior of burning materials may become a material characteristic to be considered in the evaluation of fire hazards in a low-gravity environment.

Quiescent experiments performed at low gravity have also shown that non-flaming combustion or smoldering may occur at the surface of exposed materials in low gravity. Samples that have seemed to extinguish during low-gravity tests have reignited upon the resumption of the gravitational influences at the end of the test. Thus the distinction between the propagation of a flame and extinction may not be as clear in the low-gravity environment as it generally is in normal gravity.

Finally, mixing of fuel vapor generated at the surface with the surrounding air can be accomplished by the propagation of the flame along the fuel surface. For fuels requiring relatively small amounts of energy for fuel generation, the flame can race ahead of the accumulation of combustion products and into a continuing supply of fresh oxygen.

The relative importance of the various mixing mechanisms, including molecular diffusion, the presence of forced flow, fuel injection from the surface, and the spreading of the flame into a fresh air supply, is determined by the properties of the fuel and the environment in which it is burning. These relative influences are not well understood and are worthy of additional study. Since fuel properties can determine the dominant mixing mechanism, the

classification of flammable materials by mixing-related properties may become a useful tool in spacecraft fire prevention and control.

### Heat Release

The rate of heat release from propagating flames is determined by the chemical energy content of the fuel, the ratio of vaporized fuel to the available oxygen at the flame, and the ratio of the time the reactants are in the vicinity of the flame to the time required for the reactants to react. Since only a narrow range of fuel-air ratios will be flammable, the location where flammable mixtures occur and the residence time of the flammable mixture in the flame zone depend largely upon the fuel-air mixing process. Thus the energy release in a propagating flame in low gravity is controlled largely by the low-gravity fluid mechanics.

### Heat Distribution

The location of the flame relative to the fuel and, to a lesser extent, the shape of the flame establish the boundary conditions for the active mechanisms of heat transfer from the flame. In the gas phase, conduction from the flame normal to the fuel surface and parallel to the surface in the direction of flame spread must be considered in the analysis of the fuel-generation feedback system. The temperature gradients that drive conducted heat in the gas phase are, in general, distorted by convection. Conduction of heat in the solid phase can also play a significant role. For fuels appearing in engineering configurations, there often exists a heat conduction path normal to the fuel surface, which provides a dissipation mechanism. Depending upon the fuel thickness, heat conduction through the fuel in the direction of flame spread can also participate in the fuel-generation feedback system.

The participating mechanisms in the flow field determine the importance of convective heat transfer. The role of convection is ambiguous, since it can provide both a mechanism to distribute additional heat to the fuel surface and a mechanism to carry heat away from the system. When viewed as a departure from diffusion-controlled flame spreading, the convecting flow field, added to a flame spreading in low gravity, almost invariably will enhance the flammability of materials. Experimental comparisons of normal and low-gravity heat convection in flame spreading are not yet available. Analysis of convection in the low-speed flows associated with low-gravity flame spreading is thus a prerequisite to an understanding of fire scenarios and the development of prevention and control strategies.

The role of radiative transport in low-gravity flame spreading is also not well understood. The optical depth of small-scale laboratory flames that have been observed in low-gravity experiments is small enough to disregard contributions of radiative transport to the fuel surface. On the other hand, the role of radiation may be prominent in dissipative losses from the fuel surface. The behavior of the fuel material surface in the combustion environment, for example, the appearance of a surface char layer, will determine the influence of this mechanism.

### LOW-GRAVITY RESEARCH FACILITIES

Ground-based, low-gravity testing has been indispensable in the study of the behavior of microgravity combustion. In addition to providing data on

low-gravity behavior, these facilities have provided valuable insight into the transitory behavior of systems. The response of a dynamic system to step or gradual changes in body forces can be used to explore the time scales of the various participating mechanisms. In addition, revelations such as the demonstration of the influence of low-speed flows on material flammability have been obtained.

Two classes of ground-based, low-gravity research facilities are available: drop towers or tubes, and specially equipped aircraft that fly short-duration, free-fall trajectories. The choice of facility for a particular experiment depends upon the elapsed time and the level of reduced accelerations required for the experiment.

Drop towers and drop tubes are truly ground-based facilities that simply provide an unobstructed vertical space in which an experimental apparatus can free-fall. True free-fall is approached by eliminating aerodynamic drag on the falling experiment either by evacuating the drop pathway or by surrounding the apparatus with a drag shield, which permits the apparatus to free-fall within the more slowly falling shield. Relative accelerations within the falling experiments are typically less than  $10^{-6}$  times normal Earth gravity (one g), while test times of no more than 6 sec are available. Experiment containers are decelerated gradually at the end of the test for reuse. Drop facilities using the drop shield technique can provide up to 10 experiments per day.

Low-gravity aircraft provide significantly longer test times, generally up to about 30 sec. The low gravity is obtained by executing a parabolic trajectory maneuver. The maneuver consists of a dive to gain airspeed, followed by a pullup and a nulling of aerodynamic and propulsion forces to achieve a free-fall over a parabolic hump. Finally, the aircraft is pulled up into level flight. The low-gravity test time is bracketed between periods of about 2 g's associated with the pullups. Experiments attached directly to the airframe experience minimum accelerations that are typically about  $10^{-2}$  g, while selected experiments can be allowed to float within a large aircraft to obtain somewhat reduced minimum accelerations. Depending upon the aircraft and the trajectory sequence, up to 40 low-gravity experiments can be performed during a single flight.

## SPACECRAFT MATERIAL FLAMMABILITY TESTING AND CONFIGURATIONS

Paul W. Ledoux  
McDonnell Douglas Astronautics Company  
Houston Operations

## BACKGROUND

As a result of the Apollo AS204 fire, NASA made a commitment to the Congress that the agency would be aware of the type and quantity of each material in the habitable area of manned spacecraft. NASA also committed to conduct flammability tests on material and configuration to verify the fire safety of manned space vehicles. Major points resulting from investigations were to (1) control the launch environment (i.e., control oxygen concentration), (2) have onboard a fire extinguishing system, (3) have a standard and controlled set of flammability requirements, and (4) conduct configuration and full-scale flammability tests.

Since the AS204 fire, NASA has had other accidents that caused a reevaluation of materials flammability in high-pressure oxygen systems. The first was the Apollo 13 incident, which was an in-flight fire in a cryogenic pressure vessel that resulted in the vessel rupture and caused an abort of a lunar landing mission. The second incident was a Shuttle ground test, where an Extravehicular Mobility Unit oxygen fire destroyed a test unit and a spacesuit and seriously injured a technician.

## PRESENT REQUIREMENTS AND TRACKING

As a result of these accidents, NASA has imposed standard flammability requirements on all spacecraft material. The requirements are prescribed at Level I (NASA HQ) via NHB 8060.1B (ref. 4). At Level II (STS Program Office) JSC 07700, vol. X, paragraph 3.5.2.1, states "Materials and processes shall be selected in accordance with JSC-SE-R-0006." This document imposes the NHB 8060.1 requirements in addition to other materials requirements such as corrosion, stress corrosion, fracture control, age life, and vacuum stability. The JSC-SE-R-0006 also requires that each element and major contractor prepare a materials control and verification plan. The Orbiter project plan is in JSC 11739 "Shuttle Orbiter Project Materials Control and Verification Program Management Procedures."

The material control procedures for the Orbiter are accomplished by the Materials Analysis Tracking and Control (MATCO) system. This system is essentially a central computerized system where all materials used in the Orbiter in both the original design and the as-built design (changes by Material Review (MR), Discrepancy Reports (DR's), and Test and Checkout Procedures (TCP)) are recorded. The documentation requirements tracked by MATCO include material usage, flammability acceptability, toxicity, age life, vacuum stability, and fluid compatibility acceptability. This system assures that all materials are reviewed, approved, and have their waivers tracked. Figure 1 has a flow diagram for this procedure.

The philosophy NASA uses in fire prevention is (1) assume an ignition source exists and a fire can start, and (2) require that any fire once started shall be self-extinguishing within a short distance. This is accomplished in the design by assuring that exposed materials are self-extinguishing as a material or when tested in the use configuration. Flammable materials must be stowed in a nonflammable container, have fire breaks along the material to prevent propagation, or be protected with a flammability barrier. There is also extensive use of fire breaks as well as proper housekeeping during the mission.

Material and configuration testing for the Shuttle is mainly at 30 percent oxygen concentration at 70 kPa (10.2 psia). This is the worst-case atmosphere during a mission and occurs 10 hr prior to an extravehicular activity (space walk). The pressure is reduced from the nominal 101 kPa (14.7 psia) and the oxygen concentration is increased to 30 percent for medical reasons to prevent the "bends" during an EVA.

The nominal atmosphere is 101 kPa (14.7 psia) with a 23.8 mass-percent oxygen concentration. However, the maximum oxygen concentration that can occur before the Caution and Warning system will initiate an alarm is 25.9 percent. NASA has tested many materials at the 23.8-, 25.9-, and 30-percent-oxygen levels for the Shuttle program. In addition, NASA has a large data base at 100 percent oxygen at 35 kPa (5 psia) and 115 kPa (16.5 psia). The data in figure 2 show how flammability of material is affected by percentage of oxygen for those materials that would be considered for spacecraft applications. This may represent the whole population of materials.

#### FLAMMABILITY CONTROL IN PRACTICE

One method used in the Shuttle vehicle to reduce flammability is to control spacing of flammable materials such as Velcro and wire ties. The Velcro is flammable, but NASA has a spacing requirement that all Velcro usage should be not more than 25 cm<sup>2</sup> (typically 2 by 2 in.) and each piece must be separated by 5 cm (2 in.) from each other piece in three dimensions. The wire tie spacing states that all wire ties must be 5 cm (2 in.) apart unless a nonflammable tie such as Teflon-coated glass ties are used.

Flammable materials must be stowed in nonflammable containers such as metal boxes or the polycarbonate stowage boxes used in the Orbiter. Other nonflammable bags may be used, such as bags made of double layer Nomex (at least 230 g/m (7.5 oz/yd) each) with a Teflon-coated glass fabric in between. NASA used Teflon-coated beta cloth for stowage bags in Apollo, but these were not durable enough for a reuse vehicle like the Shuttle. Nonflammable bags for wet stowage have been made by making a bag out of two layers of Nomex fabric (230 g/m (7.5 oz/yd)) with an inside layer of neoprene-coated nylon.

The inside of the Orbiter is additionally protected from a major fire by compartmentation of the electronics. For example, the many electronic areas are each in their own compartment to minimize the spread of a fire. Each compartment has either fire extinguisher nozzles from the central fire extinguishing system or has fire extinguisher access ports in front of the panel for the hand-held fire extinguisher to be used to put out a fire. In addition, wire bundles are routed in trays when exposed to the cabin to ensure that the wire bundles cannot be damaged.

NASA has used several techniques to protect flammable materials or components that must be used either in the design or the operations of the Shuttle. Examples include wrapping plastics with aluminum tape as a fire barrier. This has been used on many small off-the-shelf items such as power screwdrivers, calculators, and other hand-held devices. Also employed are nonflammable sleeves made of beta cloth or double layers of Nomex, nonflammable coatings, etc.

There have been over 30 tests on electronic "black boxes". These range from hermetically sealed units backfilled with an inert gas to air-cooled electronic boxes. Most of those made of a nonflammable container passed the configuration test. Those that failed had flammable materials on the outside or used urethane foam in the box with a large void space. The boxes that were air cooled had to meet the following conditions to pass a configuration test (i.e., no flames outside the box): (1) have air flows below 3.7 m/sec (12 ft/sec) or above 9 m/sec (30 ft/sec), (2) have the vent holes covered with a steel screen of 100 mesh or greater, and (3) assure that the flowing air did not create a "chimney effect" by having a straight path from the inlet to outlet.

#### FUTURE NEEDS

There are still some flammability problem areas or applications that could be improved. One of the areas that could be improved is the fire extinguisher. The present extinguisher medium is Halon 1301. This material has several shortcomings, including (1) the products produced in fighting a fire are corrosive to electronics and are toxic, (2) it has limited effectiveness above 33 percent oxygen concentration, (3) it requires care in usage to ensure that sufficient quantity is put on the fire.

The water emulsion system used on Apollo was very effective, but there was always the concern about water on electrical systems.

Other areas that could use some innovation are (1) clothing for the crew during the mission, (2) nonflammable foams for cushions, and (3) paper and cardboard for flight data files and cuecards.



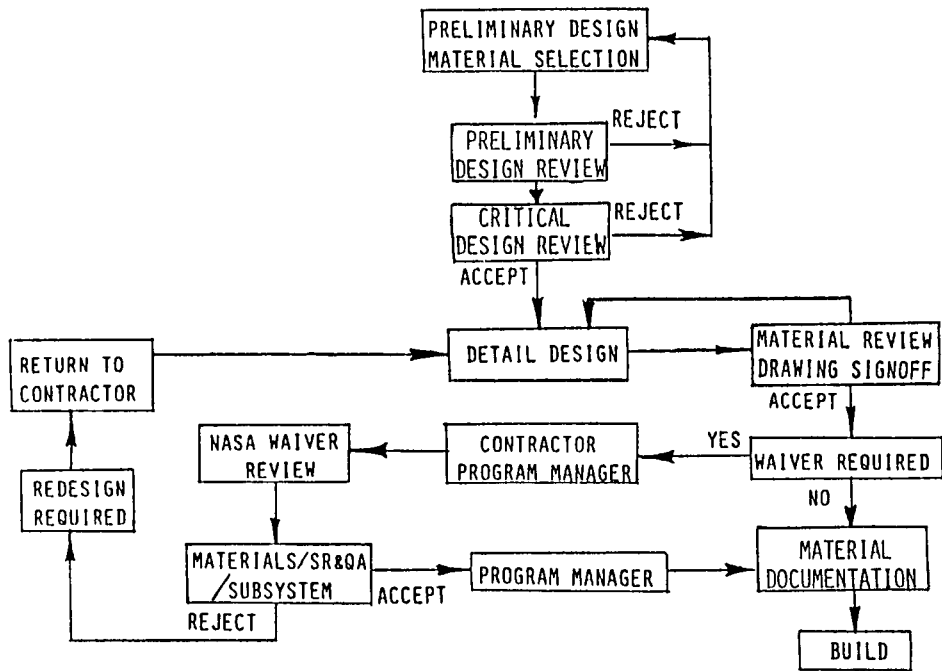

Figure 1. - Review logic for Shuttle material acceptance.

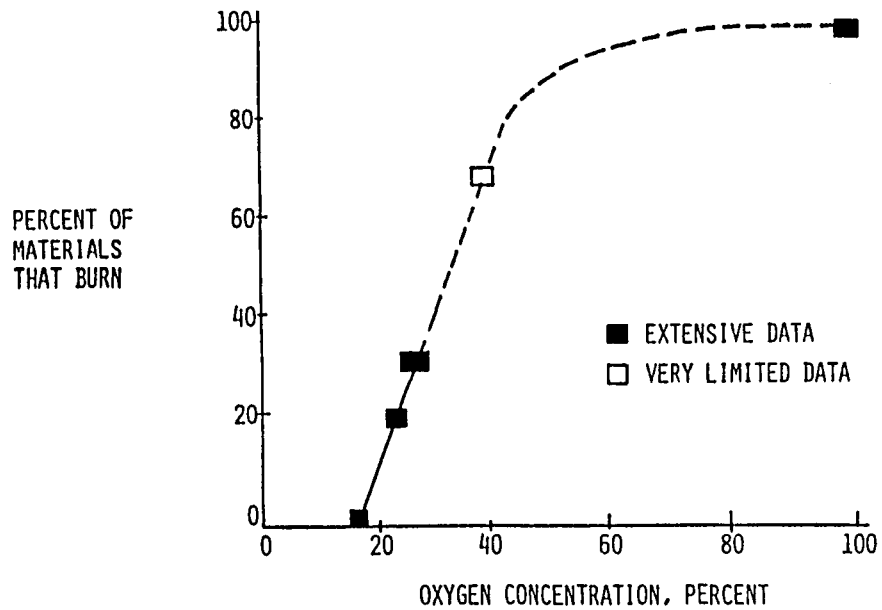

Figure 2. - Data on material flammability as function of oxygen concentration.

## IGNITION AND COMBUSTION OF METALS IN OXYGEN

Frank J. Benz  
NASA JSC White Sands Test Facility

and

S. Zhu  
Lockheed Engineering and Management Services Company

## IGNITION PROPERTIES OF METALS

During the oxidation of metals that precedes ignition, the products adhere to the metal surfaces as solid oxide coatings. If the oxide coatings are tough and impervious to oxygen, they can inhibit further oxidation and subsequent ignition of metals. For example, the ignition temperatures of metals have been observed to remain unchanged or even increase as oxygen pressure is increased (ref. 151). Oxide coatings can affect the ignition temperatures of metals by changing the overall oxidation kinetics of the metals and/or acting as a physical barrier separating the unreacted portions of the metal from the surrounding oxygen (ref. 152).

The effects of oxide coatings on the oxidation of metals are complex, and entire texts have been written on the subject (refs. 153 and 154). Laurendeau (ref. 151) categorized oxide coatings as either being protective or nonprotective. Oxidation rates for metals that form protective coatings are dependent on electric field-induced transport of metal ions through n- or p- oxide coating, oxygen diffusion along pores in oxide coatings, and other mechanisms (ref. 155). Metals that form nonprotective oxide coatings act as if they have fresh metal surfaces, and the oxidation rates are dependent on physical and/or chemical adsorption of oxygen on the metal surface. In general, oxidation rates for metals that form protective oxide coatings are slower and less dependent on pressure than oxidation rates for metals that form nonprotective oxide coatings (refs. 152 and 155).

In the case of oxide coatings acting as physical barriers, the ignition properties of zinc provide an excellent example. The oxide coating produced by zinc encapsulates the unreacted zinc, separating it from the surrounding oxygen. As the temperature is increased in a static system, the vapor pressure of zinc will eventually exceed the strength of the oxide coating. The oxide coating fails, releasing zinc vapor, which immediately ignites with the surrounding oxygen. Increasing the surrounding oxygen pressure requires a greater vapor pressure or temperature to fail the oxide coating, which results in an apparent increase in the zinc ignition temperature. In a static system, aluminum will ignite when the melting temperature of its oxide is achieved. The ignition temperature of aluminum as oxygen pressure is increased remains essentially constant, since the melting temperature of the oxide is independent of pressure.

Dynamic conditions that are characteristic of many ignition situations can compromise the protectiveness of the oxide coatings and cause a decrease in the temperatures or energy inputs required for ignition. For example, the

ignition temperature of aluminum determined in static bomb tests was approximately 2100 K (ref. 151), whereas, in frictional heating tests where samples of aluminum were rubbed together, aluminum ignited at temperatures below 700 K (ref. 156). Another example is aluminum samples that were impacted with single stainless steel particles (ref. 157). The total kinetic energy of the particles was less than 0.8 J, and only a small portion of this energy was converted to heat. The results indicated that aluminum ignited at bulk temperatures below 650 K. It is believed that during the impact process thin fibers of fresh aluminum metal were produced, which ignited and caused combustion of the entire samples. Thus, it is important that the source of the energy stimulus be carefully considered to ascertain the effects the stimulus will have on the protectiveness of oxide coatings.

An increase in oxygen pressure has, for many years, been viewed as causing an increase in the potential for metals to ignite. Tests conducted at the NASA White Sands Test Facility (WSTF), in which metals were rubbed against themselves in oxygen, have revealed that increasing oxygen pressure does not always increase the potential for ignition. It is believed that there exists specific pressures, above which, convective heat loss due to the higher oxygen density will overcome the potential increase in the oxidation rate afforded by the increase in oxygen pressure. Test results have shown that, once a specific oxygen pressure was exceeded, greater rates of frictional energies were required for ignition of metals as pressure was increased (ref. 156). Other test results have indicated that as oxygen pressure was increased during the rubbing process, the bulk sample equilibrium temperatures decreased. These results support the belief that increases in convective heat loss as pressure is increased can raise the energy requirements for ignition of metals or lower their ignition potentials. Testing has also indicated that, when metals were exposed to a rubbing process and oxygen pressure was increased, metals such as carbon steel exhibited a decrease in their bulk ignition temperature, whereas other metals such as Monel showed bulk ignition temperatures independent of pressure. It is believed that these results reflect the ability of certain metal oxides to retain their protectiveness even under dynamic conditions. A test effort at WSTF is presently being conducted to determine if similar pressure effects observed in the frictional heating tests are also characteristic of other ignition sources, such as ignition of metals by impact of particles entrained in flowing oxygen at high velocities.

#### COMBUSTION PROPERTIES OF METALS

Metals can burn as either vapors or liquids. This appears to be related to the boiling points and flame temperatures of metals. A comparison of these properties is listed in table I for aluminum that burns as a vapor and iron that burns as a liquid. The flame temperatures of metals are limited by enthalpy considerations at the metal oxide boiling points (ref. 152).

In burning of bulk metals such as solid metal rods, measuring burn propagation rates ( $V$ ) can aid in the understanding of the combustion properties of metals. Metal rods in a vertical position and ignited at the top (downward propagation) exhibit  $V$ 's which were generally greater than  $V$ 's for the same metal rods ignited at the bottom (upward propagation). The effect for the larger  $V$ 's observed for downward propagations was attributed to hot molten mass (produced from combustion) that had dripped down the rods and preheated or ignited the unreacted portions of the rods (ref. 158). In the case of

upward propagations, the hot molten masses attached themselves to the bottom of the rods and were held by surface tension. As the size of the molten masses increased, the weight of the molten masses eventually exceeded the force of the surface tension holding the molten masses to the rods. The molten masses detached from the rods and dropped away from the rods. Heat transfer required to support combustion of the rods was limited to the cross-sectional area at the molten mass/rod attachment points.

Much has been learned about the overall combustion process of bulk metals by studying the upward burn propagation of solid metal rods. The transfer of heat, required to support combustion of the rod, is believed to occur at the interface where the molten mass attaches itself to the rod. Temperature differences generated by the hot molten mass and the relatively colder solid rod are believed to cause convection currents in this region and provide the dominant mechanism for heat transfer (ref. 159). All other heat transfer paths such as radiation or conduction were considered to be negligible.

Detachment of molten masses from the rod appeared to have very little effect on the  $V$  observed for mild steel that burns as a liquid (ref. 160). However, in the case of aluminum, which burns as a vapor,  $V$  was observed to be highly dependent on the detachment of the molten mass (ref. 158). The  $V$  appeared to be at a maximum during the initial growth of the molten mass. At some point in the growth of the molten mass,  $V$  decreased to a smaller value and continued at this smaller value until detachment of the droplet again occurred; the cycle then repeated itself. The decrease in  $V$  was attributed to the formation of vapor aluminum bubbles as the molten mass temperature reached the boiling point of aluminum. These vapor bubbles were believed to have lowered the heat transfer coefficient at the molten mass/rod boundary layer. The formation of vapor bubbles probably also hastened the detachment of the molten mass by lowering the surface tension of molten mass.

As the diameters of the rod were increased,  $V$  decreased for metals that burn as liquids and vapors (refs. 158 and 161). The decrease in  $V$  was attributed to greater conductive heat loss through the rod as compared to the increase in heat generated by combustion as the diameter of the rods were increased.

The effects of increasing oxygen pressure on  $V$  again depended on whether the metals burn as liquids or vapors. Metals that burn as liquids exhibited increases in  $V$  as pressure was increased, and this was attributed to the increase in the oxidation rate (refs. 160 and 162). However, in the case of aluminum that burns as a vapor,  $V$  was observed to increase, decrease, and then increase as pressure was increased (refs. 158 and 161). Sato et al. (ref. 158) attributed this variation in  $V$  to the combination of an increase in the boiling temperature of aluminum and an increase in the heating rate of the molten mass. Both these effects will change the time required to reach the boiling point of aluminum.

## POSSIBLE EFFECTS OF ZERO GRAVITY ON IGNITION AND COMBUSTION

### PROPERTIES OF METALS

The effects of zero gravity on the ignition characteristic of metals will probably be small, since many of the ignition sources observed in real systems

involve dynamic conditions, such as frictional heating produced in rubbing processes, impact of particles, and adiabatic compression ignition of oil or soft-goods, which in turn ignite metals (kindling chain). Since the pre-ignition oxidation products are solids, convective mass transfer near the metal surfaces does not appear to be important in the oxidation kinetics in normal gravity, and thus the elimination of gravity should have no effect. However, in static systems where heat transfer due to free convection is important, changes in the ignition process may occur when gravity is eliminated.

Combustion tests performed in normal gravity may not be in some cases adequate for describing the combustion properties in zero gravity. In static systems under normal gravity, differences are observed for upward and downward burning of metals, and elimination of gravity will most likely produce large changes in these combustion properties. For example, in zero gravity, the molten mass will not detach and fall away from the rod as observed in upward propagation, and the molten mass will not drip down the rods as observed in downward propagation. In zero gravity, the molten mass will probably continue to grow at the surface of metal, and the effective area for heat transfer may increase from that observed in upward propagation in normal gravity. However, elimination of gravity will eliminate the convective currents at the interface boundaries, and heat transfer may have to occur by some slower mechanisms such as conduction or radiation. In the case of metals that burn as vapors, it is unclear at this time how the vapor bubbles in the molten mass will behave.

In dynamic systems, many of the effects that zero gravity may have on the combustion properties of metals may be small compared to the dominant effects the dynamic conditions will have on the combustion process.

When ignition and combustion of metals are compared, combustion appears to be inherently more susceptible to the effects of zero gravity; and, if testing in zero gravity is planned, combustion tests should be carried out first as opposed to ignition tests.

TABLE I. - COMPARISON OF METAL COMBUSTION PROPERTIES

	Aluminum	Iron
Metal melting temperature, K	932	1860
Metal boiling temperature, K	2720	3160
Oxide melting temperature, K	2323	1700 (FeO) 1900 (Fe <sub>3</sub> O <sub>4</sub> )
Oxide boiling temperature, K	3800	2070 (FeO) 3690 (Fe <sub>3</sub> O <sub>4</sub> )
Flame temperature, K	3300	3000

omit  
70  
END

## FORUM 1 - FIRE DETECTION AND IGNITION

### General Findings and Conclusions

Any fire that occurs in a spacecraft must be considered extremely hazardous. Hence, the principal goal of fire detection onboard spacecraft is the sensing of impending abnormalities prior to combustion. Moreover, if a fire does start onboard, the fire detection system must be capable of providing a very rapid response. At the same time, false alarms, which may prove disruptive to the mission, must be minimized.

Many failures begin with overheating of components. To detect this condition, a proposed technique involves the coating of components with micro-encapsulated indicator chemicals. These coatings are of such a nature that an indicator is released when a component reaches a temperature indicative of abnormal operation. Any substance, as long as it is nontoxic, noncorrosive, and capable of being detected by chemical or biological sensors, is suitable. These coatings may also produce color changes, which aid in locating specific components in need of repair. This technique needs also to be adapted to the detection of nonvisible combustion, or smoldering, which may occur in foamed materials at relatively low temperatures.

Regardless of whether fire detection systems sense overheating or whether they sense incipient fires, the requirement for rapid response to small sources implies the need for relatively large numbers of sensors with high sensitivity. These are needed to minimize the time required to transport the abnormal condition (fire signature) from the combustion source to the detector. This is particularly critical in microgravity where buoyant convection is nonexistent, although, due to ventilation systems, forced convection may be present.

One way of increasing the amount of information available to the onboard fire detection system without increasing the probability of false alarms is to employ a system of sensors that responds to several different fire signatures. These signatures can then be converted into analog signals and sent to a processor that recognizes patterns indicative of a fire. Such analog fire detection systems with decision algorithms in the central processor are currently under development for use in buildings in Europe and Japan.

For the development of appropriate sensors, particularly in the case of incipient fires, a data base of the fire signatures (gases, particulates, and radiation) released by the materials within the spacecraft is necessary. It is important that this data base also include fire signatures for combustion in nonstandard atmospheres and for low-temperature "smoldering" pyrolysis or combustion.

Minimizing signature transport time requires a large number of sensors. Those presently in use are relatively heavy. For example, the Shuttle fire detector has a mass of over 1 kg. To avoid a serious weight penalty, micro-sensors are needed. The technology that may have the potential to provide such sensors has been developed by H. Wohltjen at the Naval Research Laboratory (ref. 163).

An alternative to individual microsensors is the use of a single sensor head, or central analytical system, to sample the spacecraft atmosphere at a number of locations. Such a system would scan a large number of individual tubes in order to pinpoint the location of the source to as small an area as possible. Detection systems employing "tube bundles" have been studied for use in underground mines where sensitive analytical equipment is housed in a protective environment. The use of fiber optics technology for these detection systems as well as for data and communication systems will not only reduce weight but will also reduce the potential for electrical fires.

In all cases, the information relayed to the crew should be as localized as possible in order to identify the source of the problem. Thus, signals should be annunciated both at the affected device or rack and at the central command and control station.

Finally, in addition to the hazard assessment of the spacecraft itself, each experiment package within the spacecraft should undergo analysis to identify associated fire hazards as well as their detection and suppression. Special precautions should be taken with potential sources such as phase-change materials and lasers. Storage of significant quantities of combustibles, including trash, should also be covered by automatic detection and suppression systems.

#### Recommendations for Research and Technology

(1) Research and engineering studies should be conducted on the detection of overheating and low-temperature smoldering. One approach is the investigation of microencapsulated coatings for individual components, a technique proposed in the past, although no practical systems exist at present.

(2) Better sensing systems need to be developed. These systems need to react to fire signatures, that is, the patterns of chemical, physical, or biological responses that are distinguishable from normal operating conditions. These systems require decision software in the central processor to respond to incipient fires while at the same time rejecting false alarms.

(3) Advanced technological development is needed on central detector systems with multiple sampling tubes and ports in order to reduce mass penalties.

(4) The engineering requirements of recommendation 2 indicate the need for more indepth studies of thermal and chemical fire signatures of spacecraft materials. It is important that this data base incorporate the unique aspects of microgravity and nonstandard atmospheres anticipated in spacecraft environments.

(5) Finally, all spacecraft equipment and procedures and all experimental packages and procedures should be thoroughly reviewed and inventoried to identify potential ignition sources. This inventory can serve not only to minimize potential ignition hazards, but also to identify sensor, sampling, and extinguishment locations for fire control.

## FORUM 2 - FIRE EXTINGUISHMENT

### General Findings and Conclusions

Manned spacecraft missions of the future will be of longer duration and will include a greater range of scientific objectives in addition to ordinary daily working activities. For these missions, it can be assumed that unwanted ignitions will occur even though large-scale fires appear unlikely.

The forum determined that, although successful fire safety designs can readily be provided for clearly identified hazards, the development of technology for the unexpected fire hazards will present the greatest challenge. A fire protection system will need to be designed to extinguish fires, decontaminate the atmosphere, and assure continued success of assigned mission priorities.

Fundamental research needs are such that models of chemical reactions occurring in diffusion flames need to be extended to low-velocity microgravity environments (e.g., low fluid strain rates). Rapid progress has been made in the theoretical understanding of the chemistry of premixed flames, including the effects of species diffusion. This knowledge now requires application to the diffusion flame characteristics of fires in microgravity. Theoretical models are needed. These models are crucial to extending our understanding of earth-based experiments to conditions in space, conditions which cannot be reproduced in the laboratory because of buoyancy effects.

Basic research is also needed in understanding the chemistry of glowing or smoldering combustion. Halon extinguishants are relatively ineffective against deep-seated fires, which are usually suppressed only by direct cooling or reduction of available oxygen for sufficient time to allow the reacting surface to cool below its critical combustion temperature. It is not clear whether there exists some gaseous agent that can suppress the deep-seated reactions thermally rather than chemically. The problem of controlling deep-seated combustion may also turn out to be critical for the fire safety of activated carbon filters, which are typically used for air purification systems onboard spacecraft.

Technological development needs are such that the choice of an extinguishment system will need to be made early in the design process to allow for development of systems tailored to the spacecraft environment. It is essential that this technology provide the spacecraft with a general-purpose fire extinguishment system capable of handling a very broad range of fire threats in terms of both origin and magnitude.

General-purpose fire-extinguishing systems proposed for spacecraft employ suppression agents such as Halons 1301 and 1211, CO<sub>2</sub>, N<sub>2</sub>, H<sub>2</sub>O liquid and H<sub>2</sub>O gas, and the perfluorocarbons CF<sub>4</sub>, C<sub>3</sub>F<sub>8</sub>, etc. The Shuttle system has Halon 1301 available. In a terrestrial environment, Halons typically extinguish flames by reducing hydroxyl radical concentrations, causing reaction times to increase relative to flow times. This mechanism, however, is probably less effective for the longer flow times characteristic of microgravity environments. In these environments, the Halons may extinguish



hydrocarbon diffusion flames by increasing soot formation leading to radiant extinguishment.

Alternative gaseous systems using CO<sub>2</sub> and N<sub>2</sub> are being considered for the future, although these systems have the drawbacks discussed in the paper by deRis. The use of fine droplet-size water sprays for general-purpose spacecraft fire extinguishment should be explored. On a per-unit-mass basis, water is about as equally effective as Halon 1301 for surface fires and is much more effective for deep-seated fires. It is readily available onboard the spacecraft and does not introduce toxicity problems. Agent cleanup can be easily achieved with dehumidifiers in the ventilation system, and uninvolved electronic equipment can be protected from the agent by compartmentalization. Moreover, although water sprays do not conduct electricity, the possibility of shock hazard through any mass of accumulated water can be minimized by using deionized water. As an added precaution, it may also be desirable to put high voltage cables inside sealed grounded conduits.

Spacecraft, in general, have a large amount of electronic equipment onboard. This equipment is inherently a potential hazard from overheating, which may generate toxic products as well as provide an ignition source. Although such equipment is generally installed in modularized compartments, the use of extinguishers using Halon poses the added difficult task of developing and installing equipment capable of removing not only the products of combustion from the enclosed atmosphere of the spacecraft, but the Halons as well.

System malfunctions due to post-fire corrosion, thought to be caused by acids contained in the products of combustion, may surface several days or even months after a fire. Although several companies offer proprietary smoke-damage cleanup services, there is doubt as to whether this new technology is adaptable to spacecraft applications. The problems of potential corrosion damage, however, will remain particularly acute as long as the space community continues to rely on Halon 1301 as a fire suppression agent and as long as there is continued reliance on halogens in cable insulations and plastics.

Strong consideration should be given to inerting the ambient gas within the electronic compartments as well as in other uninhabited high-risk areas. While several inert gases are candidates, the most feasible is nitrogen-enriched air generated by an onboard inert gas generation system (OBIGGS). A molecular sieve, or permeable membrane, could provide a continuous purge of sealed compartments equipped with suitable heat exchangers. Manual venting to the vacuum of outer space should also be considered. In an extreme emergency, this method could be used to rapidly dispose of absorbed corrosive gases.

Certain areas of the spacecraft may have especially hazardous atmospheres, for example, the hyperbaric and oxygen-enriched chambers. These will undoubtedly require additional regulation with respect to content. Special consideration of the extinguishment agent type and distribution may be required in these areas.

It is essential to completely remove all toxic gases from the inhabited areas immediately after a fire. If Halons are used for fire extinguishment, they must also be removed. A formidable technological challenge is the development of suitable air cleaning equipment to handle this task. If suitable cleanup equipment cannot be developed, or if the total amount of toxic

products exceeds the available capacity of the equipment, then personnel must exit the contaminated areas immediately. Meanwhile, temporary vacuum depressurization of the abandoned module would help ensure elimination of corrosive gases adsorbed on surfaces. All electronic components would, however, have to be selected to withstand prolonged exposure to vacuum.

Coordination of fire safety efforts with other organizations should be encouraged. For example, the similarities between fire safety problems in submarines to those in spacecraft form the groundwork for mutually advantageous cooperative efforts between the Navy and NASA. Consideration should also be given to the establishment of a Spacecraft Fire Protection Standards Committee under the auspices of the National Fire Protection Association. Lastly, particularly difficult technological challenges might be best resolved through the formation of working groups in order to take advantage of the technical expertise already available in existing organizations.

### Recommendations for Research and Technology

(1) A fundamental research program is needed. This program should be directed at obtaining a good scientific understanding of both the combustion behavior of combustible materials, including smoldering, and the effectiveness of various flame suppressants in microgravity.

(2) Applied testing and evaluation are required. These are needed to establish the relative performance capabilities of promising candidate fire extinguishants in spacecraft atmospheres of interest under microgravity conditions. Candidate agents should include Halons 1301 and 1211, CO<sub>2</sub>, N<sub>2</sub>, water, foam, and perfluorocarbons (CF<sub>4</sub>, C<sub>3</sub>F<sub>8</sub> and higher molecular-weight compounds).

(3) Special extinguishing techniques are needed in specific areas of the spacecraft. These include the need for the development of onboard nitrogen inert gas generation systems (OBIGGS) utilizing molecular sieve or permeable membrane techniques to provide continuous purging of electronic compartments and other normally uninhabited high-risk areas. Other special fire protection needs are in the areas of the spacecraft/space station that must periodically be utilized as oxygen-enriched hyperbaric chambers.

(4) Special preplanning of post-fire atmosphere purification is needed. In addition to effective fire detection/extinguishment, provisions must also be made for isolation of individual spacecraft compartments, local de-energization of electrical power, venting of vitiated atmospheres, and eventual restoration of a safe, breathable atmosphere.

(5) Because of the similarity of the fire safety problems associated with submarine and spacecraft systems, a closer working interface between the Navy and NASA should be established to foster the development of an enhanced fire protection capability. Consideration should also be given to the establishment of a government-industry fire protection standards committee and, where required, technological working groups.

## FORUM 3 - HUMAN RESPONSES TO COMBUSTION PRODUCTS

### AND INERT ATMOSPHERES

#### General Findings and Conclusions

The study of human responses to fire hazards onboard spacecraft seeks a fundamental statement on the philosophy of spacecraft fire safety. The probability and nature of accidental fires in a microgravity environment are unknown. The approach to fire containment is somewhat vague. The real question is whether a strict fire prevention policy is needed or whether fire control, in view of the microgravity environment, is sufficient.

In order to address the aforementioned concerns, much can be gained by collating safety policies, technical reports, and case studies on the histories of fire-related incidents onboard spacecraft, aircraft, and submarines. Attention should focus on the data from actual fires and "near misses." The data could be used to mitigate potentially catastrophic situations. They could prove to be beneficial, not only from an engineering standpoint, but also from a human response perspective. The collated information might indicate the performance of spacecraft life-support systems during and after fires. It might also help to establish a baseline for onboard atmospheres for specific missions, information that could prove crucial in the early detection of incipient fires.

Test results of materials in fires onboard commercial aircraft have shown that synthetic polymers may yield products of combustion that are substantially different than those produced by the same materials burned in controlled laboratory settings. These results, therefore, point to the need for testing of spacecraft materials in full-scale, earth-based laboratories. The products generated by pyrolysis, or smoldering combustion, an occurrence which may take place even in so-called inert atmospheres, must also be investigated.

There is satisfactory evidence available from earth-based studies to indicate that reduced oxygen atmospheres sufficient to sustain life will retard combustion. The lower propagation rates will also allow firefighters more time to bring fires under control. Consequently, these nonstandard atmospheres, as discussed in forum 5, need to be studied by medical scientists in order to identify the minimum oxygen concentrations required by humans to perform long-term scientific duties effectively.

Inert atmospheres may not be practical for all areas of the spacecraft; thus, more must be learned about the toxic effects of both combustion and pyrolysis products in microgravity. Particular medical attention must be paid to the toxicity of halogenated fire extinguishants and their reaction products.

Pyrolysis, smoldering, or minor fires, even if they occur rarely, will contribute to the background contaminants found in the spacecraft environment. Over a period of time, these contaminants will accumulate in the enclosed environment of a permanently deployed spacecraft. Effective cleanup procedures for these gases are questionable. The inhalation of these contaminant gases may degrade the judgement and task-performance ability of the crew before it impairs their ability to escape from a fire. Since this is an important

operational concern, work must be done to determine the effect of combustion and extinguishant products on human performance in both normal and micro-gravity environments.

Effective standards and tolerances for human subjects are lacking. The biological end points frequently used for combustion toxicology tests, namely neuromuscular incoordination, sensory irritation, and escape behavior of trained animals, may be inappropriate for extrapolation to humans confined in a spacecraft environment.

Finally, although materials and procedures onboard spacecraft are strictly regulated, past experience cites instances whereby materials were carried onboard by crewmembers in violation of fire safety policies. Moreover, as missions increase in duration to 90 days, or longer, the "vehicular" spacecraft will become an "apartment-factory" capsule. Boredom may threaten any fire safety program based on written regulations and sound logic. Therefore, despite the dangers of permitting highly combustible materials onboard the spacecraft, the need for supportive recreation may require acceptance of books, movie films, and other flammable materials within the vehicle habitat. As a result, all crewmembers will need to be trained to fight fires. They will also need to maintain their fire-fighting skills by conducting drills during actual missions. Consequently, this will require the use of well-defined operating procedures based on examples of specific fire scenarios.

#### Recommendations for Research and Technology

(1) NASA document NHB 8060.1B, "Flammability, Odor, and Offgassing Requirements and Test Procedures for Materials in Environments that Support Combustion," (ref. 4) should be revised to include the requirements for reviewing spacecraft materials for the toxicology of their combustion or pyrolysis products. A wide variety of contributors to this document should be sought from outside NASA.

(2) The policies, literature, and experiences pertaining to fire safety should be reviewed to establish the conditions relating to incipient fires, life support systems and hazards, and the effect on human responses.

(3) Further research and technology are needed on the combustion, pyrolysis, and fire extinguishment products expected under microgravity conditions.

(4) Biological research and human clinical studies are needed to establish responses to reduced oxygen concentrations and nonstandard atmospheres. They are also needed to establish acceptable long-term tolerances to pollutants in the confined atmosphere of the spacecraft.

(5) Fire fighting skills of all crewmembers must be promoted. On every mission, one crewmember should be designated as the mission's fire marshal.

## FORUM 4 - SPACECRAFT MATERIALS AND CONFIGURATIONS

### General Findings and Conclusions

The forum participants agreed that a wealth of material and configuration acceptance standards has been developed throughout the space program. The new generation of human space missions, however, demands new approaches as well as changes to existing safety requirements. The Space Station presents an even greater challenge to designers and manufacturers. It is to be used for 20 to 30 years and, thus, requires rugged hardware capable of withstanding even the most dangerous situations.

The almost permanent nature of the Space Station suggests that structural or component aging may be of concern. Studies need to be initiated in both normal and microgravity conditions to determine the effects of aging on material flammability. Included in the studies should be consideration of the effects on materials exposed over the years to normal wear, cleaning, and continued exposure to solvents.

Changes other than material aging can be expected during the useful lifetime of the Space Station. For example, manufacturers occasionally make what are considered to be minor changes in their products. These changes may, however, have major effects on flammability limits of the materials. This is a problem that the designer as well as the materials engineer must bear in mind.

The current NASA material selection, evaluation, and control criteria are described in NHB 8060.1B (ref. 4). These testing standards are applicable to all portions of the spacecraft. Nevertheless, the major emphasis is on the crew cabin. This is because this area has an oxygen-enriched atmosphere on occasion and because the other areas are only considered flammable during ground operations and during a short period of time while launching and landing.

There are, of course, flammable materials in the Shuttle payload. These, however, are isolated and should not pose a threat. The flammable materials within the main decks are, for the most part, contained in nonflammable boxes that have been tested or analyzed to insure they are incapable of contributing to a major fire. Other flammable materials are isolated or separated by fire barriers in order to prevent establishment of propagation paths.

Since NHB 8060.1B covers conventional flammability of materials, a question that arose several times at the Spacecraft Fire Safety Workshop concerned the control of nonvisible combustion, or smoldering. The requirements in NHB 8060.1B state that a material or configuration cannot smolder for more than 10 min. However, it was felt that more consideration should be given to the potential problem of smoldering in the spacecraft environment itself. Furthermore, these tests should recognize the potential evolution of toxic products during noncombustive overheating. A particular example is the known degradation of polytetrafluorethylene, which may be used in power cable insulations.

Flammability tests are based on a worst-case atmosphere in the spacecraft itself. At present the Shuttle atmosphere is established at two levels during orbital operations. The normal level is the sea-level condition of 101 kPa

(14.7 psia) with 21 mole-percent oxygen. The oxygen-enriched level is 70 kPa total pressure with 30 mole-percent oxygen. The latter is used 12 to 24 hrs prior to an Extravehicular Activity (EVA). This preconditioning is necessary to avoid the buildup of nitrogen bubbles in body tissues (the bends) caused by the sudden pressure change from cabin to spacesuit. Mobility of the hand joints within the EVA suit presently limit the spacesuit pressure to 30 kPa maintained by a 100-percent oxygen atmosphere.

The forum Selection of Spacecraft Atmospheres discussed atmospheres of reduced-oxygen mole fractions that are capable of supporting human activities while decreasing material flammability. The atmosphere recommended would have a total pressure of 150 kPa (22 psia) and an oxygen mole fraction of 0.12. Since the Space Station is currently designed for a maximum working pressure of 140 kPa (20 psia) and a bursting pressure of 165 kPa (24 psia), increasing the normal total pressure to 150 kPa (22 psia) would require major structural changes and a large weight increase. In addition, most experiments onboard the Space Station are designed for an atmosphere approximating sea-level conditions of 101 kPa (14.7 psia) and 20.9 mole-percent oxygen. Nevertheless, the technology for such innovations in future-generation spacecraft should be explored.

The forum participants discussed other hazards that might occur despite strict adherence to materials and configuration standards. A broken or damaged line, or piece of hardware, may allow gases or fluids into the habitable area of the spacecraft. Future designs should assure that lines carrying hazardous gases or fluids be routed outside the habitable area.

Finally, the forum expressed its concern that the expertise developed in spacecraft and aircraft flammability will be lost if the personnel now active in this area retire or leave. There is strong sentiment that the space research and design community be asked to make a determined effort to document the "lessons learned." This information if compiled and published would ensure that the "tricks of the trade" are documented and that the same mistakes are not repeated. Furthermore, analogies between fire-safe materials and configuration practices established for aircraft should be pursued in terms of spacecraft.

#### Recommendations for Research and Technology

(1) Flammability testing on spacecraft materials and configurations should be conducted in low-gravity environments in order to understand ignition and flame spread in various assemblies and configurations in addition to the effectiveness of associated fire suppression systems. Spontaneous combustion in low gravity should also be studied.

(2) Further testing should be conducted on nonburning pyrolysis of common materials. These tests should define not only the toxic gases to which the crew might be exposed but should also indicate what type of gases may be needed to be removed by the life support system. Assuming gas analysis equipment is onboard, the data could be used in a fire detection system capable of looking for those gases peculiar to the burning or smoldering of major materials used. The data could also be used to determine whether certain equipment is overheating and is about to fail.

(3) The updating of flammability information should include studies on the effect of aging of materials on flammability not only in normal gravity but in microgravity as well.

(4) Flammability models created for aircraft should be expanded to include Space Station flammability hazards. In addition, past practices and current knowledge in aircraft and spacecraft material flammability should be compiled and reviewed to establish a documented data bank.

## FORUM 5 - SELECTION OF SPACECRAFT ATMOSPHERES

### General Findings and Conclusions

The discussion on selection of spacecraft atmospheres concentrated on three main topics: fire-suppressant atmospheres for long-term operation, impact of extinguishants on atmospheres, and fire behavior in unusual environments.

The use of an inert, or fire-suppressant, atmosphere is a relatively easy way to reduce fire hazards. In spacecraft this may be accomplished by reducing the mole fraction (or percent) of oxygen to below that of normal air. In contrast, increasing the mole fraction of oxygen can increase the fire hazard potential. Thus, there is real concern over the present practice of using oxygen concentrations above 21 mole percent in spacecraft. Moreover, as noted in the forum Spacecraft Materials and Configurations, the spacecraft atmosphere of 30 mole-percent oxygen at 70 kPa (10 psia) needed in preparation of extravehicular activities presents a highly dangerous situation even at this low total pressure.

The forum considered three options for fire-suppressant atmospheres acceptable for sustaining life. The first, a total pressure of 150 kPa (1.5 atm) and a mole fraction of oxygen of 0.12, has a partial pressure of oxygen of 18 kPa, equivalent to that at an altitude of 1350 m (4400 ft), and is as close to a "combustion free" atmosphere as possible within the constraints of sustaining human life. Some participants felt that the total pressure should be raised as high as possible to guarantee a habitable fire-safe atmosphere with a minimum oxygen mole fraction. There are formidable engineering drawbacks to be addressed with the use of this atmosphere, such as structural strength, major engineering redesigns, docking, isolation of compartments in the capsule, development of air locks, etc. Thus, a second option might be a total pressure of 100 kPa (1 atm) and as low a mole fraction of oxygen as is necessary to meet the physiological requirements needed for operation of the Space Station. The forum agreed that the oxygen mole fraction of this atmosphere should be no less than 0.16. This is equivalent to the partial pressure at an altitude of 2300 m (7500 ft), which is the normal pressurization level inside high-altitude commercial airliners. It is recognized that this atmosphere is not as "combustion free" as the first option, but it is still much safer than the current spacecraft atmosphere from a fire standpoint. (Note: this oxygen partial pressure has served as the basis for other studies, including the paper by Knight on human responses, which is presented elsewhere in this publication.)

A third option proposed by the forum calls for a habitable atmosphere containing inertants other than nitrogen. Although life on earth has evolved in an atmosphere containing 79 percent nitrogen and although we have much experience with this atmosphere both physiologically and in terms of fire behavior, other inertants should be considered. Helium, for example, which was used in SeaLab, does not present a significant advantage from a fire standpoint. The same applies to argon, another inert gas. However, if gases with considerably higher molar specific heats than nitrogen are used, the quenching effect of these inertants permits use of higher mole fractions of oxygen while yielding the same benefits as nitrogen with respect to fire



suppression. Gases such as  $\text{CF}_4$ ,  $\text{SF}_6$ , and  $\text{C}_2\text{F}_6$  have been studied for this purpose (ref. 164). Even though the forum felt their use in spacecraft may not be feasible, the participants stressed the need for further investigation of these gases. Also, it should be noted that the use of diluents other than nitrogen may eliminate the need for high-oxygen conditioning prior to extravehicular activities.

Diluents that are also extinguishants, such as  $\text{CO}_2$  and  $\text{CF}_3\text{Br}$  (Halon 1301), are considered too toxic for use at the concentrations required for fire protection. For example, the concentration of  $\text{CO}_2$  required is approximately 40 percent, which is lethal. The halogenated extinguishant, Halon 1301, is toxic, and it is known that Halon systems develop slow leaks. These extinguishants may be used if the contaminated spacecraft atmosphere is vented to space and the original atmosphere reconstituted. Although this is an extreme means of fire extinguishment, it is highly effective.

The use of deionized water as an extinguishant also needs to be explored. However, consideration must be given to the electrical equipment which might be rendered inoperable after soaking in water or other liquid extinguishants.

Extinguishment in itself has drawbacks. Foremost is the contamination of the spacecraft atmosphere by suppressant residues or reaction products. Hence, it is inherently better to prevent fires by inerting rather than to fight fires after they start.

Finally, the forum expressed concern over the paucity of information on the impact of unusual environments on both fires and physiological behavior and response. Of particular concern in connection with spacecraft were the following topics:

- (1) Effect of unusual atmospheres on fires and physiology, including use of diluent gases other than  $\text{N}_2$  (e.g.,  $\text{CF}_4$ ,  $\text{SF}_6$ , etc.)
- (2) Effect of unusual atmospheres on spacecraft equipment
- (3) Fire behavior with forced air circulation at microgravity conditions
- (4) Effect of  $\text{O}_2$  concentration on flaming and smoldering combustion
- (5) Establishment of different atmospheres in different spacecraft modules (e.g., normal oxygen, low oxygen)
- (6) Isolation of high fire risk areas in order that they may be totally inerted or extinguished with water, for example

It is the opinion of the forum that these areas need to be addressed by a vigorous long-term research and development program that will achieve sufficient basic understanding of the phenomenology involved to allow design and performance of spacecraft at maximum efficiency and minimum risk from fire.

## Recommendations for Research and Technology

(1) Research and technology programs should be conducted on the adaptation and implementation of the three fire-suppressant atmospheres suggested by this forum, namely

- (a) Twelve percent  $O_2$  at 150 kPa (1.5 atm) total pressure
- (b) Sixteen percent  $O_2$  at 100 kPa (1.0 atm) total pressure (or the lowest  $O_2$  mole fraction that is physiologically acceptable)
- (c) Atmospheres with high-specific-heat diluents

(2) More general research is needed on the effects of unusual environments, including the atmospheres proposed in recommendation 1, on combustion, combustion products, and human physiology. Research should include investigations of pyrolysis and smoldering combustion (i.e., combustion that may occur even in inert atmospheres).

(3) In addition to proposed research, a data bank should be established to collate knowledge on fire behavior in unusual environments (e.g., inert atmospheres, microgravity, etc.).

(4) Further research is warranted on contamination of the spacecraft atmosphere by extinguishants as well as on the procedure of isolation and venting.

## REFERENCES

1. DeMeis, R.: Safety in the Space Station. Aerospace America, vol. 24, no. 5, May 1986, pp. 26-29.
2. Peercy, R.L., Jr.; Raasch, R.F.; and Rockoff, L.A.: Space Station Crew Safety Alternatives Study, Vol. 1 - Final Summary Report. NASA CR-3854, 1985.
3. Fletcher, J.C.: Now More Than Ever. Aerospace America, vol. 24, no. 9, Sept. 1986, pp. 24-27.
4. Flammability, Odor, and Offgassing Requirements and Test Procedures for Materials in Environments That Support Combustion. NASA TM-84066, 1981. (NASA NHB-8060.1B).
5. Raasch, R.F.; Peercy, R.L., Jr.; and Rockoff, L.A.: Space Station Crew Safety Alternatives Study, Vol. II - Threat Development. NASA CR-3855, 1985.
6. Kimzey, J.H.: Flammable and Toxic Materials in the Oxygen Atmosphere of Manned Spacecraft. NASA TN D-3415, 1968.
7. Friedman, R.; and Sacksteder, K.R.: Science and Technology Issues in Spacecraft Fire Safety. AIAA Paper 87-0467, Jan. 1987.
8. Fox, D.G.: Development of Feasibility Demonstration Hardware for an Integrated Fire and Overheat Detection System. AFAPL-TR-72-105, May 1973. (Avail. NTIS, AD-762919).
9. Fry, J.F.: The Problem of False Alarms from Fire Detector Systems. Proceedings of the Conference on Problems in Automatic Fire Detection, Aachen, Germany, Oct. 4-6, 1971.
10. Bukowski, R.W.; and Istvan, S.M.: A Survey of Field Experience with Smoke Detectors in Health Care Facilities. NBSIR-80-2130, Oct. 1980. (Avail. NTIS, PB81-132276).
11. Custer, R.L.P.; and Bright, R.G.: Fire Detection: The State-of-the-Art. NBS-TN-839, National Bureau of Standards, 1974. (NASA CR-134642).
12. Foster, W.W.: Attenuation of Light by Wood Smoke. Br. J. Appl. Phys., vol. 10, Sept. 1959, pp. 416-420.
13. ASTM Fire Test Standards. Building Seals and Sealants; Fire Standards; Building Constructions, 1986 Annual Book of ASTM Standards, Vol. 4.07, ASTM, 1986.
14. Standard Guide for Room Fire Experiments. ASTM E-603-77 (Reapproved 1983), American Society for Testing and Materials, Philadelphia, 1986.
15. Proposed Standard Method for Room Fire Test of Wall and Ceiling Materials and Assemblies. 1982 Annual Book of Standards, American Society for Testing and Materials, Philadelphia, 1982.

16. Babrauskas, V.: Bench-Scale Methods for Prediction of Full-Scale Fire Behavior of Furnishings and Wall Linings. Society of Fire Protection Engineers, SFPE Technology Report 84-10, 1984.
17. Babrauskas, V.; and Walton, W.D.: A Simplified Characterization of Upholstered Furniture Heat Release Rates. Fire Safety J., 1987. (to be published.)
18. Wickstrom, U.G.; and Goransson, U.: Prediction of Heat Release Rates of Large Scale Room Fire Tests Based on Cone Calorimeter Results. To be published in J. Test. Eval., vol. 15, 1987.
19. Flammability Testing for the Screening of Space Materials. European Space Agency, ESA PSS-01-721, Issue 1, Oct. 1982.
20. Measuring the Minimum Oxygen Concentration to Support Candle-Like Combustion of Plastics (Oxygen Index). ASTM D-2863-77, American Society for Testing and Materials, 1986.
21. Sibulkin, M.; and Little, M.W.: Propagation and Extinction of Downward Burning Fires. Combust. Flame, vol. 31, no. 2, 1978, pp. 197-208.
22. Bulewicz, E.M.: Some Notes on the Oxygen Index and Inflammability Limits, Archiwum Termodynamiki i Spalania, vol. 7, 1976, pp. 175-190.
23. Kanury, A.M.: Theoretical Analysis of Fire and Flammability Tests, Part 3, The Limiting Oxygen Index Test. Fire Safety of Combustible Materials, University of Edinburgh, Centre for Industrial Consultancy and Liaison, 1975, pp. 187-198.
24. Bukowski, R.W.: An Introduction to Fire Hazard Modeling, NBSIR-86-3349, 1986.
25. Reeves, J.B.; and MacArthur, C.D.: Dayton Aircraft Cabin Fire Model, Vol. 1- Basic Mathematical Model, FAA-RD-76-120-VOL-1, 1976. (Avail. NTIS, AD-A033682).
26. Drysdale, D.: An Introduction to Fire Dynamics. Wiley, 1985.
27. Martin, S.: Diffusion-Controlled Ignition of Cellulosic Materials by Intense Radiant Energy. Tenth Symposium (International) on Combustion, The Combustion Institute, Pittsburgh, 1965, pp. 877-896.
28. Thomas, P.H.: Some Conduction Problems in the Heating of Small Areas on Large Solids. Quart. J. Mech. Appl. Math., vol. 10, pt. 4, 1957, pp. 482-493.
29. Hermance, C.E.: Solid-Propellant Ignition Theories and Experiments. Fundamentals of Solid-Propellant Combustion, K.K. Kuo and M. Summerfield, eds., AIAA, 1984, pp. 239-304.
30. Fire Tests - Reaction to Fire - Ignitability of Building Products, Draft International Standard, ISO/DIN-5657, International Organization for Standardization, 1985.

31. Standard Test Method for Heat and Visible Smoke Release Rates for Materials and Products. ASTM E-906-83, American Society for Testing and Materials, 1986.
32. Proposed Test Method for Heat and Visible Smoke Release Rates for Materials and Products Using an Oxygen Consumption Calorimeter. ASTM P-190, American Society for Testing and Materials, 1986.
33. Babrauskas, V.; and Parker, W.J.: Ignitability Measurements with the Cone Calorimeter. NBSIR-86-3445, 1986.
34. Standard Test Method for Surface Burning Characteristics of Building Materials. ASTM E-84-84, American Society for Testing and Materials, 1986.
35. Airworthiness Standards: Transport Category Airplanes, Federal Aviation Regulations, Vol. III, Section 25.853, Transmittal 10, effective May 1, 1972.
36. Recommendation on Fire Test Procedures for Surface Flammability of Bulkhead and Deck Finish Materials. Res. A.564(14), suppl., Res. A.516(13), A.166(ES.IV). International Maritime Organization, London, 1986.
37. Quintiere, J.G.; and Harkleroad, M.T.: New Concepts for Measuring Flame Spread Properties. Fire Safety: Science and Engineering, ASTM STP-882, T. Harmathy, ed., American Society for Testing and Materials, 1985, pp. 239-267.
38. Dietenberger, M.A.: Mathematical Modeling of Furniture Fires. University of Dayton, NBS-GCR-86-506, 1986.
39. Huggett, C.: Estimation of Rate of Heat Release by Means of Oxygen Consumption Measurements. Fire Mater., vol. 4, no. 2, June 1980, pp. 61-65.
40. Babrauskas, V.: The Cone Calorimeter-A Versatile Bench-Scale Tool for the Evaluation of Fire Properties. New Technology to Reduce Fire Losses and Costs, S.J. Grayson and D.A. Smith, eds., Elsevier Applied Science Publishers, London, 1986, pp. 78-87.
41. Standard Test Method for Specific Optical Density of Smoke Generated by Solid Materials. ASTM E-662-83, American Society for Testing and Materials, 1986.
42. Babrauskas, V.; Levin, B.C.; and Gann, R.G.: A New Approach to Fire Toxicity Data for Hazard Evaluation. ASTM Standardization News, vol. 14, no. 9, Sept. 1986, pp. 28-33.
43. Kanury, A.M.: Ignition of Cellulosic Solids: Minimum Pyrolysate Mass Flux Criterion. Combust. Sci. Technol., vol. 16, nos. 1-2, 1977, p. 89.
44. McAlevy, R.F., III; Cowan, P.L.; and Summerfield, M.: The Mechanism of Ignition of Composite Solid Propellants by Hot Gases. Solid Propellant Rocket Research, M. Summerfield, ed., Academic Press, 1960, pp. 623-652.

45. Kumar, R.K.; and Hermance, C.E.: Gas Phase Ignition Theory of a Heterogeneous Solid Propellant Exposed to a Hot Oxidizing Gas. *Combust. Sci. Technol.*, vol. 4, no. 5, Jan. 1972, pp. 191-196.
46. Kashiwagi, T.: A Radiative Ignition Model of a Solid Fuel. *Combust. Sci. Technol.*, vol. 8, nos. 5-6, 1974, pp. 225-236.  
also: Simms, D.L.: Comment on "A Radiative Ignition Model of a Solid Fuel" by T. Kashiwagi. *Combust. Sci. Technol.*, vol. 14, nos. 1-3, 1976, pp. 119-122.
47. Magee, R.S.; and McAlevy, R.F., III: Mechanism of Flame Spread. *J. Fire Flammability*, vol. 2, Oct. 1971, pp. 271-297.
48. Fernandez-Pello, A.C.; and Hirano, T.: Controlling Mechanisms of Flame Spread. *Combust. Sci. Technol.*, vol. 32, no. 1-4, 1983, pp. 1-31. (*Fire Sci. Technol.*, vol. 2, no. 1, 1982, pp. 17-54.)
49. Frey, A.E., Jr.; and T'ien, J.S.: Near-Limit Flame Spread Over Paper Samples. *Combust. Flame*, vol. 26, 1976, pp. 257-267.
50. Altenkirch, R.A.; Eichhorn, R.; and Shang, P.C.: Buoyancy Effects on Flames Spreading Down Thermally Thin Fuels. *Combust. Flame*, vol. 37, no. 1, Jan. 1980, pp. 71-83.
51. Tewarson, A.: Flammability of Polymers and Organic Liquids, Part I, Burning Intensity. Factory Mutual Research Corp., FMRC Technical Report 22429, Feb. 1975.
52. Tewarson, A.; and Steciak, J: Fire Ventilation. NBS-GCR-83-423, Feb. 1983.
53. Santo, G.; and Tamanini, F.: Influence of Oxygen Depletion on the Radiative Properties of PMMA Flames. Eighteenth Symposium (International) on Combustion, The Combustion Institute, Pittsburgh, 1980, pp. 619-631.
54. Zabetakis, M.G.: Flammability Characteristics of Combustible Gases and Vapors. U.S. Bureau of Mines Bulletin 627, 1965. (Avail. NTIS, AD-701576).
55. Beyer, R.B.; and Fishman, N.: Solid Propellant Ignition Studies with High Heat Flux Radiant Energy as a Thermal Source. *Solid Propellant Rocket Research*, M. Summerfield, ed., Academic Press, 1960, pp. 673-692.
56. Shannon, L.J.: Composite Solid-Propellant Ignition by Radiant Energy. *AIAA J.*, vol. 8, no. 2, Feb. 1970, pp. 346-353.
57. Kashiwagi, T., et al.: Ignition of Polymers in a Hot Oxidizing Gas. *Combust. Sci. Technol.*, vol. 8, no. 3, 1973, pp. 121-131.
58. Ohlemiller, T.J.; and Summerfield, M.: Radiative Ignition of Polymeric Materials in Oxygen/Nitrogen Mixtures. Thirteenth Symposium (International) on Combustion, The Combustion Institute, Pittsburgh, 1971, pp. 1087-1094.

59. Alpert, R.L.: Pressure Modeling of Fires Controlled by Radiation. Sixteenth Symposium (International) on Combustion, The Combustion Institute, Pittsburgh, 1976, pp. 1489-1500.
60. Kimzey, J.H.: Flammability During Weightlessness. NASA TM X-58001, 1966.
61. Strehlow, R.A.; and Reuss, D.: Flammability Limits in a Standard Tube. Combustion Experiments in a Zero-Gravity Laboratory, T.H. Cochran, ed., AIAA, 1981, pp. 61-89.
62. Schreihans, F.A.: Flammability Characteristics of Some Organic Spacecraft Materials in Zero Gravity. NASA CR-92833, 1965.
63. Altenkirch, R.A.; Eichhorn, R.; and Rizvi, A.R.: Correlating Downward Flame Spread Rates for Thick Fuel Beds. Combust. Sci. Technol., vol. 32, no. 1-4, 1983, pp. 49-66.
64. Hall, A.L.: Observations on the Burning of a Candle at Zero Gravity. Naval School of Aviation Medicine, Report No. 5, Feb. 1964, (Avail. NTIS, AD-436897).
65. Spalding, D.B.: The Combustion of Liquid Fuels. Fourth Symposium (International) on Combustion, Williams & Wilkins Co., Baltimore, 1953, pp. 847-864.
66. Judd, M.D.; and Meehan, J.: Flammability Testing of Materials for the European Spacelab. Interflam 1985 Workbook, W.D. Wooley and S.P. Rogers, eds., Univ. of Surrey, Guilford, England, 1985, pp. 243-250.
67. Dorr, V.A.: Fire Studies in Oxygen-Enriched Atmospheres. J. Fire Flammability, vol. 1, Apr. 1970, pp. 91-106.
68. Botteri, B.P.; Cretcher, R.E.; and Kane, W.R.: Aircraft Applications of Halogenated Hydrocarbon Extinguishing Agents. An Appraisal of Halogenated Fire Extinguishing Agents, W.J. Christian and R.C. Wands, eds., National Academy of Science, Washington, D.C., 1972, pp. 215-238. (Avail. NTIS, AD-753218 or PB-218448/9).
69. Stewart, R.D., et al.: Human Exposure to Halon 1301. Dept. of Environmental Medicine, The Medical College of Wisconsin, Milwaukee, WI, June 1978.
70. Krasner, L.M.: Study of Hand-Held Extinguishers Aboard Civil Aviation Aircraft. FAA/CT-82/42, June 1982. (Avail. NTIS, AD-A138652).
71. Eklund, T.I.: Analysis of Dissipation of Gaseous Extinguisher Agents in Ventilated Compartments. FAA/CT-83/1, May 1983.
72. Steere, N.V., ed.: CRC Handbook of Laboratory Safety, 2nd Ed., CRC Press, 1971.
73. NFPA Fire Protection Handbook, 16th ed., National Fire Protection Assoc., Quincy, MA, 1986.

74. Lugar, J.R.: Fine Water Mist Fire Protection System. DTNSRDC Letter 2843: JRL Series 9555, Dec. 1979.  
  
Also David Taylor Naval Ship R&D, Technical Memo 2843: TM-28-81-210, Aug. 1981.
75. Alpert, R.L.: Calculated Interaction of Sprays With Large-Scale Buoyant Flows. J. Heat Trans., vol. 106, no. 2, May 1984, pp. 310-317.
76. Alpert, R.L.: Calculated Spray Water-Droplet Flows in a Fire Environment. Factory Mutual Research Corp., FMRC RC86-BT-6, Oct. 1986.
77. Report of Apollo 204 Review Board to the Administrator. NASA TM-84105, 1967, and associated appendices, NASA TM-84099, NASA TM-84100, NASA TM-84101, NASA TM-84102, NASA TM-84103, NASA TM-84104, NASA TM-84106, NASA TM-84107, NASA TM-84108, NASA TM-84109, NASA TM-84110, NASA TM-84111, NASA TM-84112, and NASA TM-84138.
78. Carhart, H.W.: Habitable Atmospheres for Undersea Craft. SAE Paper 670534, June 1967.
79. Johnson, J.E.; and Woods, F.J.: Flammability in Unusual Atmospheres. Part I - Preliminary Studies of Materials in Hyperbaric Atmospheres Containing Oxygen, Nitrogen and/or Helium. NRL-6470-PT-1, Oct. 1966. (Avail. NTIS, AD-644556).
80. Johnson, J.E.; and Woods, F.J.: Flammability in Unusual Atmospheres. Part II - Selected Materials in Oxygen-Nitrogen and Oxygen-Helium Mixtures at Pressures up to 315 PSIA. NRL-6606, Sept. 1967. (Avail. NTIS, AD-823059L).
81. Lewis, B.; and von Elbe, G.: Combustion, Flames and Explosions of Gases. 2nd ed., Academic Press, 1961.
82. Coward, H.F.; and Jones, G.W.: Limits of Flammability of Gases and Vapors. U.S. Bureau of Mines Bulletin 503, 1952. (Avail. NTIS, AD-701575).
83. Belles, F.E.; and Swett, C.C.: Ignition and Flammability of Hydrocarbon Fuels. Basic Considerations in the Combustion of Hydrocarbon Fuels with Air, NACA Report 1300, 1957, Chapter III, pp. 277-320.
84. Carhart, H.W.; and Fielding, G.H.: Applications of Gaseous Fire Extinguishants in Submarines. An Appraisal of Halogenated Fire Extinguishing Agents, W.J. Christian and R.D. Wands, eds., National Academy of Science, Washington, D.C., 1972, pp. 239-256.
85. Beller, R.C.; Carhart, H.W.; DiNunno, P.J.; Scheffey, J.L.; Stone, J.P.; Tatem, P.A.; and Williams, F.W.: Design Study for Nitrogen Pressurization Firefighting System for Submarines, NRL Memorandum Report (in preparation).
86. Dressler, D.P., et al.: Biological Effect of Fire Suppression by Nitrogen Pressurization in Enclosed Environments. J. Combust. Toxicology, vol. 4, Aug. 1977, pp. 314-324.



87. Alexander, J.I., et al.: Submarine Hull Insulation Fire Test IV - 7 Dec. 1981. NRL Report 8727, July 1983.
88. Galasyn, V.D.: A Survey of Fire-Prevention Problems in Closed Oxygen-Containing Environments. SMRL-526, Naval Submarine Medical Center, 1968. (Avail. NTIS, AD-675817).
89. Huggett, C.: Combustion Processes in the Aerospace Environment. Aerospace Medicine, vol. 40, no. 11, Nov. 1969, pp. 1176-1180.
90. Harter, J.V.: Fire at High Pressure. Proceedings of the Third Symposium on Underwater Physiology, C.J. Lambertsen, ed., Williams & Wilkins Company, Baltimore, 1967, pp. 55-80.
91. Alexander, J.I., et al.: Submarine Hull Insulation Fire Test VII, 25 August 82. NRL Report 8872, Mar. 1985.
92. Moritz, A.R., et al.: Studies of Thermal Injury. A.M.A. Archives of Pathology, vol. 43, 1947, pp. 466-488.
93. Gaume, J.G.; Bartek, P.; and Rostami, H.J.: Experimental Results on Time of Useful Function (TUF) after Exposure to Mixtures of Serious Contaminants. Aerospace Medicine, vol. 42, no. 9, Sept. 1971, pp. 987-990.
94. Kaplan, H.L.; Grand, A.F.; and Hartzell, G.E.: Combustion Toxicology: Principles and Test Methods. Technomic Publishing Company, Lancaster, PA, 1983.
95. Fire Safety Aspects of Polymeric Materials. Vol. 3 - Smoke and Toxicity NMAB-318-3. National Academy of Sciences, Washington, D.C., 1978.
96. Treitman, R.D.; Burgess, W.A.; and Gold, A.: Air Contaminants Encountered by Firefighters. Am. Ind. Hyg. Assoc. J., vol. 41, no. 11, 1980, pp. 796-802.
97. Burgess, W.A., et al.: Minimum Protection Factors for Respiratory Protective Devices for Firefighters. Am. Ind. Hyg. Assoc. J., vol. 38, no. 1, 1977, pp. 18-23.
98. Terrill, J.B.; Montgomery, R.R.; and Reinhardt, C.F.: Toxic Gases from Fires. Science, vol. 200, no. 4348, June 23, 1978, pp. 1343-1347.
99. Mead, G.H.; Percy, R.L., Jr.; and Raasch, R.F.: Space Station Crew Safety Alternatives Study, Volume V - Space Station Safety Plan. NASA CR-3858, 1985.
100. Richmond, D.R., et al.: The Relationship Between Selected Blast-Wave Parameters and the Response of Mammals Exposed to Air Blast. Prevention of and Protection Against Accidental Explosion of Munitions, Fuels and Other Hazardous Mixtures, E. Cohen, ed., Ann. New York Acad. Sci., vol. 152, art. 1, Oct. 28, 1968, pp. 103-121.

101. Cook, G.A.; Dorr, V.A.; and Shields, B.M.: Region of Noncombustion in Nitrogen-Oxygen and Helium-Oxygen Diving Atmospheres. Ind. Eng. Chem, Proc. Des. Dev., vol. 7, no. 2, Apr. 1968, pp. 308-311.
102. Desmarais, L.A.; and Tolle, F.F.: Integrated Aircraft Fuel Tank Inerting and Compartment Fire Suppression System. Vol. 1- Preliminary Design, Optimization and Integration; Vol. 2 - Evaluation of Nitrogen-Enriched Air as a Fire Suppressant. AFWAL-TR-83-2021-VOL-1, -2, Apr. 1983. (Avail. NTIS, AD-B078139L and AD-A134883).
103. Dukek, W.G.; Ferraro, J.M.; and Taylor, W.F.: Static Electricity Hazards in Aircraft Fuel Systems. AFAPL-TR-78-56, Aug. 1978. (Avail. NTIS, AD-A061450).
104. Grenich, A.F.; and Tolle, F.F.: Electrostatic Safety with Explosion Suppressant Foams. AFWAL-TR-83-2015, Mar. 1983. (Avail. NTIS, AD-A137503).
105. Hankins, D.: Molecular Sieve Inerting System for Aircraft Fuel Tank, Part No. 3261021-0101. AFWAL-TR-82-2102, Oct. 1982. (Avail. NTIS, AD-A136480).
106. Hogan, T.A.; and Pedriani, C.: Flame Tube and Ballistic Evaluation of Explosafe Aluminum Foil for Aircraft Fuel Tank Explosion Protection. AFWAL-TR-80-2031, Apr. 1980. (Avail. NTIS, AD-A093542).
107. Johnson, R.L.; and Gillerman, J.B.: Aircraft Fuel Tank Inerting System. AFWAL-TR-82-2115, July 1983. (Avail. NTIS, AD-A141863).
108. Kirklin, P.W.; and Rhynard, D.L.: Factors Affecting Electrostatic Hazards. AFAPL-TR-78-89, Dec. 1978. (Avail. NTIS, AD-A065927).
109. Martel, C.R.; Bright, A.W.; and Farrer, D.B.: Static Charge in Aircraft Fuel Tanks. AFWAL-TR-80-2049, Sept. 1980. (Avail. NTIS, AD-A093552).
110. Mills, J.S.: Electrostatic Charging in Reticulated Foam. AFWAL-TR-81-2015, Mar. 1981. (Avail. NTIS, AD-A098526).
111. Szego, A.; Premji, K.; and Appleyard, R.D.: Evaluation of Explosafe Explosion Suppression System for Aircraft Fuel Tank Protection. AFWAL-TR-80-2043, July 1980. (Avail. NTIS, AD-A093125).
112. Snyder, C.E., Jr.: Nonflammable Hydraulic Systems Overview. AIAA Paper 81-1716, Aug. 1981.
113. Gandee, G.W.: Flammability Assessment of Hydraulic Fluids. AIAA Paper 81-1717, Aug. 1981.
114. Gschwender, L.J.: Nonflammable Fluid Development. AIAA Paper 81-1718, Aug. 1981.
115. Graham, T.L.: Seal Materials Development for Nonflammable Fluids. AIAA Paper 81-1719, Aug. 1981.

116. Berner, W.E.: Dynamic Evaluation of Sealing System Materials for Nonflammable Fluids. AIAA Paper 81-1720, Aug. 1981.
117. Campbell, W.B.: Nonflammable Hydraulic Component/Systems Development. AIAA Paper 81-1721, Aug. 1981.
118. Parts, L.; and Olt, R.G.: High Temperature (1645 °C, 3000 °F) Surface Ignition Test Apparatus for Fluids. AFWAL-TR-82-2110, Mar. 1983. (Avail. NTIS, AD-A132658).
119. Parts, L.: Assessment of the Flammability of Aircraft Hydraulic Fluids. AFAPL-TR-79-2055, July 1979. (Avail. NTIS, AD-A076512).
120. Springer, R.J., et al.: Advanced Ultra-Violet (UV) Aircraft Fire Detection System. Vol. I - System Description and Flight Test, Vol. II - System Hardware Design, Software Design and Test, Vol. III - Ground Support Equipment (GSE) for System Check-Out. AFWAL-TR-82-2062-VOL-1, -2, -3, Aug. 1982. (Avail. NTIS, AD-A121253, AD-A121721, and AD-A130298).
121. Aircraft Fuels, Lubricants, and Fire Safety. AGARD-CP-84-71, 1971.
122. Aircraft Fire Safety. AGARD-CP-166, 1975.
123. Propulsion and Energetics Panel Working Group II on Aircraft Fire Safety. Vol. 1 - Executive Summary, Vol. 2 - Main Report. AGARD AR-132, Nov. 1979. (Avail. NTIS, AD-A078671).
124. Enders, J.H.; and Wood, E.C.: Special Aviation Fire and Explosion Reduction (SAFER) Advisory Committee. FAA-ASF-80-4-VOL-1, -2A and -2B, June 1980. (Avail. NTIS, AD-A092016, AD-A099147, and AD-A099176).
125. Aviation Fuel Safety, 1975. Coordinating Research Council, CRC-482, Nov. 1975.
126. Aircraft Fire Safety. AGARD-LS-123, June 1982. (Avail. NTIS, AD-A116380).
127. Sarkos, C.P.: New FAA Regulations Improve Aircraft Fire Safety. ASTM Standardization News, vol. 13, no. 12, Dec. 1985, pp. 33-39.
128. Ertel, I.D.; Newkirk, R.W.; and Brooks, C.G.: The Apollo Spacecraft: A Chronology, Vol. IV, NASA SP-4009-VOL-4, 1978, p. 159.
129. Hoffman, J.R.: NASA Skylab Program Working Paper, Skylab Orbital Assembly Fire Study, NASA Manned Spacecraft Center, MSC-04084, Apr. 1971.
130. Orbiter Crash and Rescue Manual. NASA Johnson Space Center, JSC-17952, Mar. 1982.
131. Kimzey, J.H.: Skylab Experiment M479, Zero Gravity Flammability. Proceedings of the Third Space Processing Symposium on Skylab Results, Vol. 1, NASA TM X-70252, 1974, pp. 115-130.

132. Mulholland, G.W.; and Liu., B.Y.H.: Response of Smoke Detectors to Monodisperse Aerosols. *J. Res. Nat. Bur. Stand.*, vol. 85, no. 3, May-June, 1980, pp. 223-238.
133. Bricker, R.W.: Test Results From a Comparative Evaluation of a Condensation Nuclei Fire Detector. NASA CR-3874, 1985.
134. Standard on Halon 1301 Fire Extinguishing Systems. NFPA 12A, 1985 edition, National Fire Protection Association, Quincy, MA.
135. Standard of Carbon Dioxide Extinguishing Systems. NFPA 12, 1985 edition, National Fire Protection Association, Quincy, MA.
136. Ronney, P.D.; and Wachman, H.Y.: Effect of Gravity on Laminar Premixed Gas Combustion I: Flammability Limits and Burning Velocities. *Combust. Flame*, vol. 62, no. 2, Nov. 1985, pp. 107-119.
137. Ronney, P.D.: Effect of Gravity on Laminar Premixed Gas Combustion II: Ignition and Extinction Phenomena. *Combust. Flame*, vol. 62, no. 2, Nov. 1985, pp. 121-133.
138. Ronney, P.D.: Effect of Gravity on Halocarbon Flame Retardant Effectiveness. *Acta Astronautica*, vol. 12, no. 11, Nov. 1985, pp. 915-921.
139. Wherley, B.L.; and Strehlow, R.A.: The Behavior of Fuel-Lean Premixed Flames in a Standard Flammability Tube Under Controlled Gravity Conditions. (UILU-ENG-86-0503, University of Illinois, Urbana; NASA Grant NCC3-35) NASA CR-177132, 1986.
140. Cochran, T.H.: Experimental Investigation of Laminar Gas Jet Diffusion Flames in Zero Gravity. NASA TN-D-6523, 1972.
141. Cochran, T.H.; and Masica, W.J.: Effects of Gravity on Laminar Gas Jet Diffusion Flames. NASA TN-D-5872, 1970.
142. Edelman, R.B.; Fortune, O.; and Weilerstein, G.: Analytical Study of Gravity Effects on Laminar Diffusion Flames. (GASL-TR-771, General Applied Science Labs; NASA Contract NAS3-14378) NASA CR-120921, 1973.
143. Edelman, R.B., et al.: An Analytical and Experimental Investigation of Gravity Effects Upon Laminar Gas Jet Diffusion Flames. Fourteenth Symposium (International) on Combustion, The Combustion Institute, Pittsburgh, PA, 1972, pp. 399-412.
144. Vedha-Nayagam, M.; and Altenkirch, R.A.: Backward Boundary Layers in Downward Flame Spread. Twentieth Symposium (International) on Combustion, The Combustion Institute, Pittsburgh, PA, 1984, pp. 1583-1590.
145. Vedha-Nayagam, M.; and Altenkirch, R.A.: Gravitational Effects on Flames Spreading Over Thick Solid Surfaces. *Acta Astronautica*, vol. 12, no. 7/8, July-Aug. 1985, pp. 565-572.
146. Olson, S.L.; and Sotos, R.G.: Combustion of Velcro in Low-Gravity. NASA TM-88970, 1987.

147. Knight, B.; and Williams, F.A.: Observations on the Burning of Droplets in the Absence of Buoyancy. *Combust. Flame*, vol. 38, no. 2, June 1980, pp. 111-119.
148. Berlad, A.L.: Multiphase Combustion Experimentation in Microgravity. IAF Paper 83-141, Oct. 1983.
149. Abramzon, B.; Edwards, D.K.; and Sirignano, W.A.: Transient Natural and Surface-Tension-Driven Convection in a Two-Layer Gas-and-Liquid Enclosure with Nonuniform Radiative Transfer. AIAA Paper 86-0578, Jan. 1986.
150. Dosanjh, S., et al.: Buoyancy Effects on Smoldering Combustion. *Acta Astronautica*, vol. 13, no. 11/12, Nov.-Dec. 1986, pp. 689-696.
151. Laurendeau, N.M.; and Glassman, I.: The Ignition Characteristics of Metals in Oxygen Atmospheres. *Combust. Sci. Technol.*, vol. 3, no. 2, Apr. 1971, pp. 77-82.
152. Glassman, I., et al.: A Review of Metal Ignition and Flame Models. *Reactions Between Gases and Solids*, AGARD CP-52, 1970, Paper 19.
153. Hauffe, K.: *Oxidation of Metals*. Plenum Press, 1965.
154. Kubaschewski, O.; and Hopkins, B.E.: *Oxidation of Metals and Alloys*, 2nd ed., Butterworth and Company, London, 1962.
155. Kofstad, P.: *High Temperature Oxidation of Metals*. Wiley, 1966.
156. Benz, F.J.; and Stolzhus, J.M.: Ignition of Metals and Alloys in Gaseous Oxygen by Frictional Heating. *Flammability and Sensitivity of Materials in Oxygen-Enriched Atmospheres*, Vol. 2, ASTM STP-910, M.A. Benning, ed., American Society for Testing and Materials, 1986, pp. 38-58.
157. Benz, F.J.; Williams, R.E.; and Armstrong, D.: Ignition of Metals and Alloys by High-Velocity Particles. *Flammability and Sensitivity of Materials in Oxygen-Enriched Atmospheres*, Vol. 2, ASTM STP-910, M.A. Benning, ed., American Society for Testing and Materials, 1986, pp. 16-37.
158. Sato, K.; Hirano, T.; and Sato, J.: Behavior of Fires Spreading Over Structural Metal Pieces in High-Pressure Oxygen. *ASME-JSME Thermal Engineering Joint Conference*, Vol. 4, Y. Mori and W.J. Yang, eds., ASME, 1983, pp. 311-316.
159. Hirano, T., et al.: The Rate Determining Process of Iron Oxidation at Combustion in High Pressure Oxygen. *Oxid. Commun.*, vol. 6, no. 1-4, 1984, pp. 113-124.
160. Sato, J.; Sato, K.; and Hirano, T.: Fire Spread Mechanisms Along Steel Cylinders in High Pressure Oxygen. *Combust. Flame*, vol. 51, July 1983, pp. 279-287.
161. Kirschfeld, L.: Combustibility of Metals in Oxygen of up to 200 Atmospheres Pressure. *Metallurgy*, vol. 21, no. 2, Feb. 1967, pp. 98-102.

162. Benz, F.; Shaw, R.C.; and Homa, J.M.: Burn Propagation Rates of Metals and Alloys in Gaseous Oxygen. Flammability and Sensitivity of Materials in Oxygen-Enriched Atmospheres, Vol. 2, ASTM STP-910, M.A. Benning, ed., American Society for Testing and Materials, 1986, pp. 135-152.
163. Haggin, J.: Faster, Smaller Integrated Sensors in Offering for Process Control. Chem. Eng. News, vol. 62, no. 23, June 4, 1984, pp. 7-13.
164. Huggett, C.: Habitable Atmospheres Which Do Not Support Combustion. Combust. Flame, vol. 20, no. 1, Feb. 1973, pp. 140-142.

1. Report No. <b>NASA CP-2476</b>		2. Government Accession No.		3. Recipient's Catalog No.	
4. Title and Subtitle <b>Spacecraft Fire Safety</b>				5. Report Date <b>August 1986</b>	
				6. Performing Organization Code <b>506-49-3B</b>	
7. Author(s)				8. Performing Organization Report No. <b>E-3464</b>	
				10. Work Unit No.	
9. Performing Organization Name and Address <b>National Aeronautics and Space Administration Lewis Research Center Cleveland, Ohio 44135</b>				11. Contract or Grant No.	
				13. Type of Report and Period Covered <b>Conference Publication</b>	
12. Sponsoring Agency Name and Address <b>National Aeronautics and Space Administration Washington, D.C. 20546</b>				14. Sponsoring Agency Code	
15. Supplementary Notes <b>Editor, J.M. Margle, Pennsylvania State University, Ogontz Campus, Abington, Pennsylvania.</b>					
16. Abstract <p>This document presents the review papers and findings of discussion forums at the Spacecraft Fire Safety Workshop, held at NASA Lewis Research Center on August 20-21, 1986. The ten invited papers by separate authors cover the subjects of fire detection, fire standards and testing, fire extinguishment, inerting and atmospheres, fire-related medical science, aircraft fire safety, Space Station safety concerns, microgravity combustion, spacecraft material flammability testing, and metal combustion. The five forums, which involved the participation of all the workshop attendees, covered the topics of fire detection, extinguishment, human effects, materials assessments, and spacecraft atmospheres. Among the important findings of the forums are recommendations for further efforts on (1) fundamental studies on microgravity combustion applicable to fire safety, (2) improved detection methods for overheating of components and incipient fire conditions, (3) extinguishing systems and postfire cleanup techniques, (4) material flammability tests applicable to the long-term microgravity environment, and (5) innovative use of inerting and fire-suppressant atmospheres.</p>					
17. Key Words (Suggested by Author(s)) <b>Combustion; Fire fighting; Fire detection; Fire extinguishers; Fire prevention; Flammability; Inerting; Microgravity applications; Space Station; Spacecraft cabins; Toxicology</b>			18. Distribution Statement <b>Unclassified - unlimited STAR Category 16</b>		
19. Security Classif. (of this report) <b>Unclassified</b>		20. Security Classif. (of this page) <b>Unclassified</b>		21. No of pages <b>127</b>	22. Price* <b>A07</b>