

N88-12521

## TECHNIQUES FOR FIRE DETECTION

Richard W. Bukowski  
Center for Fire Research  
National Bureau of Standards

## INTRODUCTION

The purpose of a fire detector is to provide the earliest warning possible of the outbreak of an unwanted fire so that appropriate actions to mitigate the consequences of the fire can be taken. These actions generally include the evacuation of occupants at risk to a safe area and the initiation of extinguishment activities, either automatic or manual. Since fires and the threat posed by them grow rapidly, earlier extinguishment means that the threat and potential for damage from the fire is minimized.

Balanced against the desire for rapid activation is the need to minimize false alarms, which disrupt normal activities and erode confidence in the detection system. Detectors that "cry wolf" too often are either ignored or disconnected, resulting in the potential for disaster. In an early 1970's report on Air Force aircraft engine nacelle fire detectors (ref. 8), Fox reported that about 83 percent of the alarms received were false and 50 percent of the fires were not detected. The latter was related to the former in that the high false alarm rate caused the crews to disconnect the detectors in order to meet flight readiness objectives. In commercial building systems, Fry (ref. 9) and Bukowski (ref. 10) both reported false to real alarm ratios of 14:1 for smoke detectors in the United Kingdom and the United States, respectively.

The balance between early warning and minimum false alarms requires that the detector selected be matched to the application in terms of the characteristics of the expected fires and the operating environment. An analysis of the combustible materials and potential ignition sources within a space to be protected can provide insight into the expected "fire signatures" that will be produced. Taking into account the characteristics of the space that will influence the transport of these products from the combustion site to the detector location and the response of the detector type selected allows the prediction of performance. Finally, the vulnerability of the space (and its contents and occupants) should be analyzed to determine the maximum fire size that can be safely tolerated in order to establish the detection goal required to provide a safe condition without being overly sensitive.

The purpose of this paper is to provide an overview of the bases for such an analysis. First, the burning process is discussed in terms of the production of the "fire signatures" normally associated with detection devices. These include convected and radiated thermal energy, particulates, and gases. Second, the transport processes associated with the movement of these from the fire to the detector, along with the important phenomena which cause the level of these signatures to be reduced, are described. Third, the operating characteristics of the individual types of detectors, which influence their

response to the signals, are presented. Finally, vulnerability analysis using predictive fire modeling techniques will be discussed as a means to establish the necessary response of the detection system to provide the level of protection required in the application.

## FIRE SIGNATURES

Fire detectors sense the presence of fire by responding to changes in their local environment that are indicative of a fire within their associated area of coverage. The goal is to select conditions for sensing that appear as early as possible and that are present at levels sufficiently above those at normal, nonfire conditions to minimize false alarms. These changes of conditions are called fire signatures. Various fire conditions may produce different fire signatures, so optimum detector system design requires that the detector types selected must be matched to the hazard present.

### Heat

Combustion is essentially an exothermic, gas-phase chemical reaction. Gaseous fuels combust by breaking bonds in the fuel molecules, forming other chemical species and releasing thermal energy. For solid or liquid fuels, some of the thermal energy is needed to produce the phase change to a gas before the actual combustion takes place. This required energy is the heat of gasification. The net remaining energy then goes to increase the temperature of the gases and air leaving the combustion zone. This hot gas rises due to buoyancy to the ceiling and spreads radially outward in a ceiling jet. The temperature and velocity of this ceiling jet govern the heat transfer rate to thermally activated detectors located on the ceiling.

### Smoke

In terms of fire detection, smoke refers to solid or liquid particles released during combustion. The solids are clusters of carbonaceous spherules formed within the fuel rich portions of the flame in a process similar to polymerization. Vapors can condense on a solid core, yielding a liquid covered smoke particle. This condensation process requires that the temperature be below the vaporization temperature while the vapor concentration is still high. In smoldering combustion, essentially all the smoke is in the form of condensed vapors. This is why the smoke from smoldering appears light colored (the liquid is largely water) and the smoke from flaming is dark (mostly carbon). This also means that the particle size from smoldering is larger than from flaming.

### Light

Flames radiate light energy over a broad spectrum. Radiation in the visible and infrared comes largely from thermal energy radiating from the carbon particles within the flame. This is why a hydrogen flame, which contains no carbon, is invisible. Ultraviolet radiation comes largely from OH radicals, and the thermally broadened OH radiation explains why alcohol flames and pre-mixed gas flames appear blue.

## Transport/Losses

Once produced by the fire, the fire signature must travel to the detector to produce a response. Depending on the signature, this transport process takes time, and losses can occur that further delay response. An understanding of this process can help to select optimum detector placement and type for the fastest response to the hazard.

The rising plume above a fire entrains cool air, which reduces the temperature and dilutes the particulate concentration. Once the plume contacts the ceiling, heat transfer reduces the temperature further, but particulate losses to the ceiling are generally small. When the ceiling jet reaches the detector, the thermal inertia of a heat detector results in a delay in response, but a smoke detector will respond immediately if the particulate concentration is high enough. This is the primary reason why smoke detectors respond faster than heat detectors for most fires.

With flame detectors, the light energy travels in a straight line almost instantaneously. Since the fire is radiating in all directions, the intensity falls off as the square of the distance from the fire to the detector and may be attenuated by any smoke particles in the radiant beam. The key thing to remember about flame detection is that the detector must be able to "see" the flame directly, although infrared energy will reflect from surfaces at a reduced level.

## HEAT DETECTION

### Types

Heat detectors are the oldest type of automatic fire detection device. They began with the development of automatic sprinkler heads in the 1860's and have continued to the present with a proliferation of different types of devices. A sprinkler can be considered a combined extinguishing device and heat-activated fire detector when the sprinkler system is provided with water flow indicators tied into the fire alarm control unit system. These water flow indicators detect either the flow of water through the pipes or the subsequent pressure drop upon actuation of the system and automatically sound an alarm as the water is being put on the fire.

Electrical heat detectors, which only sound an alarm and have no extinguishing function, are also used. Heat detectors are the least expensive fire detectors, have the lowest false alarm rate of all fire detectors, but are also the slowest in detecting fires. Heat detectors are best suited for fire detection in small confined spaces where rapidly building, high heat output fires are expected and in other areas where ambient conditions would not allow the use of other fire detection devices or where speed of detection or life safety are not the prime consideration. One example of this would be low value protection where fire could cause minimum damage to the structure or contents. Heat detectors may be thought of as detecting fires within minutes of ignition.

Heat detectors respond to the convected thermal energy of a fire and are generally located at or near the ceiling. They may respond either at a predetermined fixed temperature or at a specified rate of temperature change.

In general, heat detectors are designed to sense a prescribed change in a physical or electrical property of a material when exposed to heat.

### Fixed-Temperature Detectors

Fixed-temperature detectors are designed to alarm when the temperature of the operating element reaches a specified point. The air temperature at the time of operation is usually higher than the rated temperature due to the thermal inertia of the operating elements. Fixed-temperature heat detectors are available to cover a wide range of operating temperatures ranging from 57 °C (135 °F) and up. Higher temperature detectors are necessary so that detection can be provided in areas that are normally subjected to high ambient (nonfire) temperatures.

Eutectic metals, alloys of bismuth, lead, tin, and cadmium, which melt rapidly at a predetermined temperature, can be used as operating elements for heat detection. The most common such use is the fusible element in an automatic sprinkler head. Fusing of the element allows water to flow in the system, which triggers an alarm by various electrical or mechanical means. A eutectic metal may be used in one of two ways to actuate an electrical alarm circuit. The simplest method is to place the eutectic element in series with a normally closed circuit. Fusing of the metal opens the circuit to trigger an alarm. The second method employs a eutectic metal as a solder to secure a spring under tension. When the element fuses, the spring action is used to close contacts and sound an alarm. Devices using eutectic metals cannot be restored. Either the device or its operating element must be replaced following operation.

Frangible glass bulbs similar to those used for sprinkler heads have been used to actuate alarm circuits. The bulb, which contains a high vapor pressure liquid and a small air bubble, is used as a strut to maintain a normally open switching circuit. When exposed to heat, the liquid expands, compressing the air bubble. When the bubble is completely absorbed, there is a rapid increase in pressure, shattering the bulb and allowing the contacts to close. The desired temperature rating is obtained by controlling the size of the air bubble relative to the amount of liquid in the bulb.

As an alternative to spot-type fixed-temperature detection, various methods of continuous line detection have been developed. One type of line detector uses a pair of steel wires in a normally open circuit. The conductors are insulated from each other by a thermoplastic of known fusing temperature. The wires are under tension and held together by a braided sheath to form a single cable assembly (fig. 1). When the design temperature is reached, the insulation melts, contact is made, and an alarm is generated. Following an alarm, the fused section of the cable must be replaced to restore the system.

A similar alarm device utilizing a semiconductor material and a stainless steel capillary tube has been developed for use where mechanical stability is a factor (fig. 2). The capillary tube contains a coaxial center conductor separated from the tube wall by a temperature-sensitive glass semiconductor material. Under normal conditions, a small current (i.e., below alarm threshold) flows in the circuit. As the temperature rises, the resistance of the semiconductor decreases allowing more current flow and triggering the alarm.

Bimetals are used for the operating elements of several types of fixed-temperature detectors. When a sandwich of two metals having different coefficients of thermal expansion is heated, differential expansion causes bending or flexing towards the metal having the lower expansion rate. This action closes a normally open circuit. The low expansion metal commonly used is Invar, an alloy of 36 percent nickel and 64 percent iron. Several alloys of manganese-copper-nickel, nickel-chromium-iron or stainless steel may be used for the high expansion component of a bimetal assembly.

Bimetal detectors are generally of two types, the bimetal strip and the bimetal snap disc. Some devices use bimetal strips placed directly in the alarm circuit. As the strip is heated it deforms in the direction of its contact point. The width of the gap between the contacts determines the operating temperature. The wider the gap, the higher the operating point. Drawbacks to this type of device are its lack of rapid positive action and its susceptibility to false alarms from vibration or jarring, particularly as the rated temperature is approached, for example, during periods of transient high ambient temperatures that are below the alarm point.

The operating element of a snap-disc device is a bimetal disc formed into a concave shape in its unstressed condition (fig. 3). As the disc is heated, the stresses developed cause it to reverse curvature suddenly and become convex. This provides a rapid positive action, which allows the alarm contacts to close. The disc itself is not usually part of the electrical circuit. Snap-disc devices are not as sensitive to false or intermittent alarms as the bimetal strips described above.

A different application of the thermal expansion properties of metals is found in the rate compensation detectors, which use metals of different thermal expansion rates to compensate for slow changes in temperature while responding with an alarm for rapid rates of temperature rise and at a fixed maximum temperature as well. For a further discussion of this device, see the section on Combination Detectors.

All thermal detectors using bimetal or expanding metal elements have the desirable feature of automatic restoration after operation when the ambient temperature drops below the operating point.

#### Rate-of-Rise Detectors

One effect that a fire has on the surrounding environment is to generate a rapid increase in air temperature in the area above the fire. While fixed-temperature heat detectors must wait until the gas temperature near the ceiling reaches or exceeds the designated operating point before sounding an alarm, the rate-of-rise detector will function when the rate of temperature change exceeds a predetermined value, typically around 8.3 °C (15 °F) per minute. Detectors of the rate-of-rise type are designed to compensate either mechanically or electrically for normal changes in ambient temperature that are expected under nonfire conditions.

The increased pressure of gas when heated in a closed system can be used to generate a mechanical force that will operate alarm contacts in a pneumatic fire detection device. In a completely closed system, actuation will occur strictly from a slow change in ambient temperature, regardless of the rate of

temperature change. The pneumatic detectors in use today provide a small opening to vent the pressure that builds up during slow changes in temperature. The vents are sized so that when the temperature changes rapidly, such as in a fire situation, the pressure change exceeds the venting rate and the system is pressurized. These systems are generally sensitive to rates of temperature rise exceeding 8.3 °C (15 °F) per minute. The pressure is converted to mechanical action by a flexible diaphragm. A generalized schematic of a pneumatic heat detection system is shown in figure 4.

Pneumatic heat detectors are available for both line and spot applications. The line systems consist of metal tubing in a loop configuration attached to the ceiling of the area to be protected. Except where specifically approved, Underwriters' Laboratories requires that lines of tubing be spaced not more than 9.1 m (30 ft) apart and that no single circuit exceed 305 m (1000 ft) in length. Zoning can be achieved by selected siting of lines or by insulating those portions of a circuit that pass through areas from which a signal is not desired.

For spot applications and in small areas where line systems might not be able to generate sufficient pressures to actuate the alarm contacts, heat collecting air chambers or rosettes are often used. These units act like a spot-type detector by providing a large volume of air to be expanded at a single location.

The pneumatic principle is also used to close contacts within spot detectors of the combined rate-of-rise/fixed-temperature type. These devices are discussed in the following section.

#### Combination Detectors

Several devices are available that use more than one operating mechanism and will respond to multiple fire signals with a single unit. The combination detectors may be designed to alarm either from any one of several fire signals or only when all the signals are present at predetermined levels.

Several heat detection devices are available that operate on both the rate-of-rise and fixed-temperature principles. The advantage of units such as these is that the rate-of-rise elements will respond quickly to rapidly developing fires, while the fixed-temperature elements will respond to slowly developing smoldering fires when the design alarm temperature is reached. The most common type uses a vented hemispherical air chamber and a flexible diaphragm for the rate-of-rise function. The fixed-temperature element may be either a bimetal strip (fig. 5) or a leaf spring restrained by a eutectic metal (fig. 6). When the designed operating temperature is reached, either the bimetal strip flexes to the contact point or the eutectic metal fuses, releasing the spring which closes the contacts.

A second device that can be classified as combination rate-of-rise/fixed-temperature is the rate-compensation detector. This detector uses a metal cylinder containing two metal struts. These struts act as the alarm contacts and are under compression in a normally open position (fig. 7). The outer shell is made of a material with a high coefficient of thermal expansion, usually aluminum, while the struts, usually copper, have a lower expansion coefficient. When exposed to a rapid change in temperature, the shell expands

rapidly, relieving the force on the struts and allowing them to close. Under slowly increasing temperature conditions both the shell and struts expand. The contacts remain open until the cylinder, which expands at a greater rate, has elongated sufficiently to allow them to close. This closure occurs at the fixed-temperature rating of the device.

### Thermoelectric Detectors

Various thermoelectric properties of metals have been successfully applied in devices for heat detection. Operation is based either on the generation of a voltage between bimetallic junctions (thermocouples) at different temperatures or variations in rates of resistivity change with temperature.

These spot-type devices, which operate in the voltage-generating mode, use two sets of thermocouples. One set is exposed to changes in the atmospheric temperature and the other is not. During periods of rapid temperature change associated with a fire, the temperature of the exposed set increases faster than the unexposed set and a net potential is generated. The voltage increase associated with this potential is used to operate the alarm circuit.

## SMOKE DETECTION

### Types

Smoke detectors are more costly than heat detectors but provide considerably faster detection times and subsequently higher false alarm rates due to their increased sensitivity. While smoke detectors are very effective for life safety applications, they are also more difficult to locate properly, since air currents, which might affect the direction of smoke flow, must be taken into consideration.

Smoke detectors are classified according to their operating principle and are of two main types: ionization and photoelectric. Smoke detectors operating on the photoelectric principle give somewhat faster response to the products generated by fires of low energy (smoldering) as these fires generally produce large quantities of visible (larger particle) smoke. Smoke detectors using the ionization principle provide somewhat faster response to fires of high energy (open flaming) as these fires produce the smaller smoke particles that are more easily detected by this type of detector.

Smoke detectors should be used to protect areas of high value and areas where life safety and fast response times are desired. Smoke detectors can operate within seconds of fire ignition.

Smoke detectors are also installed in return air ducts of ventilating (HVAC) systems in large buildings to prevent recirculation of smoke through the HVAC system from a fire within the building. Upon detection, the associated control system is designed to automatically shut down the circulating blowers or to change them over to a smoke exhaust mode. Smoke-activated devices are also used to automatically close smoke doors in large buildings in order to limit the spread of smoke in case of fire. This may be done with separate corridor-ceiling mounted smoke detectors connected to

electrically-operated hold-open devices on the doors or smoke detectors that are built into the door closure units themselves.

### Ionization Detectors

Ionization chambers have been used for many years as laboratory instruments for detecting microscopic particles. In 1939 Ernst Meili, a Swiss physicist, developed an ionization chamber device for the detection of combustible gases in mines (ref. 11). The major breakthrough in the field resulted from Meili's invention of a special cold-cathode tube, which would amplify the small signal produced by the high impedance detection circuit sufficiently to trigger an alarm circuit. This reduced the electronics required and resulted in a practical detector. In most models today, the cold-cathode tube has been replaced with solid state circuitry, which further reduces the size and cost.

The basic detection mechanism of an ionization detector consists of an alpha or beta radiation source in a chamber containing positive and negative electrodes. Alpha radiation sources are commonly americium-241 or radium-226, and the strength of the sources generally range from 2000 to 3 000 000 disintegrations per second (0.05 to 80  $\mu\text{Ci}$ ). The alpha radiation in the chamber ionizes the oxygen and nitrogen molecules in the air between the electrodes causing a small current (of the order of  $10^{-11}$  A) to flow when voltage is applied (fig. 8).

When a smoke aerosol enters the chamber, it reduces the mobility of the ions, and therefore the current flow between the electrodes (fig. 9). The resulting change in the current in the electronic circuit is used to trigger an alarm at a predetermined level of smoke in the chamber. The ionization chamber detector reacts to both visible and invisible components of the products of combustion. It responds best to particle sizes between 0.01 and 1.0  $\mu\text{m}$ .

Depending on the placement of the alpha source, two types of chambers, unipolar or bipolar, may be produced. A unipolar chamber is created by using a tightly collimated alpha source placed close to the negative electrode, thus ionizing only a small part of the chamber space (fig. 10). With this configuration, most of the positive ions are collected on the cathode, leaving a predominance of negative ions flowing through the chamber to the anode. The bipolar chamber has the alpha source centrally located so that the entire chamber space is subject to ionization (fig. 11). The unipolar chamber is theoretically a unipolar and bipolar chamber in series (figs. 10 and 12). That is, there is a purely unipolar section and a section which contains ions of both polarities.

A comparison of the relative merits of the two types of chamber design indicates that the unipolar chamber has approximately three times the sensitivity of the bipolar configuration. The reason for the increased sensitivity is believed to be due to the fact that there is less loss of ion carriers by recombination, i.e. neutralization of ions of opposite signs, which occurs in the bipolar chamber. This results in a higher signal-to-noise ratio and a stronger alarm signal to the amplifier circuit.

The alarm signal in an ion chamber detector is generated by a voltage shift at the junction between a reference circuit and the measuring chamber.



The voltage shift results from a current decrease in the measuring chamber when products of combustion are present. The reference circuit may be either electronic or a second ion chamber only partially open to the atmosphere (fig. 13). These circuits are referred to as single chamber and dual chamber, respectively. The dual chamber has an advantage in the reduction of false alarms due to changes in ambient conditions. The reference chamber will tend to compensate for slow changes in temperature, pressure, and humidity.

It should be noted that some ion chamber detector designs are subject to changes in sensitivity with varying velocity of air entering the sampling chamber. Detectors with unipolar chamber designs move slightly away from alarm as velocity increases and are the most stable over wide variations in airflow. Detectors with bipolar chamber designs move toward alarm as velocity increases, and some may shift sufficiently in the more sensitive direction to trigger a false alarm. Care must be taken to choose the appropriate design for the area to be supervised.

Tests have indicated that ion chamber detectors are not suitable for use in applications where high ambient radioactivity levels are to be expected. The effect of radiation is to reduce the sensitivity. Tests also indicate that false alarms can be triggered by the presence of ozone or ammonia.

Ion chamber detectors are available for both industrial and domestic use. Models are produced for both single station and system applications. Power supply requirements vary from 240 and 120 V ac or 6 to 24 V dc for use with fire alarm systems to battery powered units using 9 to 13.5 V dc for residential use.

### Photoelectric Detectors

The presence of suspended smoke particles generated during the combustion process affects the propagation of a light beam passing through the air. This effect can be utilized to detect the presence of a fire in two ways: (1) attenuation of the light intensity over the beam path length, and (2) scattering of the light both in the forward direction and at various angles to the beam path.

The theory of light attenuation by aerosols dispersed in a medium is described by the Lambert-Beer Law. It states that the attenuation of light is an exponential function of the beam path length ( $l$ ), the concentration of particles ( $c$ ), and the extinction coefficient of the particles ( $k$ ). This relationship is expressed as follows (ref. 12):

$$I = I_0 e^{-kcl}$$

where  $I$  is the transmitted intensity at length  $l$  and  $I_0$  is the initial (clear air) intensity of the light source.

Smoke detectors that utilize attenuation consist of a light source, a light beam collimating system, and a photosensitive cell (fig. 14). In most applications, the light source is an incandescent bulb, but lasers and light emitting diodes (LED's) are also used in newer photoelectric aerosol detectors. Light emitting diodes are a reliable long life source of illumination with low current requirements. Pulsed LED's can generate sufficient light intensity for use in detection equipment.

The photosensitive device may be either a photovoltaic or photoresistive cell. The photovoltaic cells are usually selenium or silicon cells, which produce a voltage when exposed to light. These have the advantage that no bias voltage is needed, but, in most cases, the output signal is low and an amplification circuit is required. These units alarm when the photocell output is reduced by attenuation of the light as it passes through the smoke in the atmosphere between the light source and the photocell. Photoresistive cells change resistance as the intensity of the incident light varies. Cadmium sulfide cells are most commonly employed. These cells are often used as one leg of a Wheatstone bridge, and an alarm is triggered when the voltage shift in the bridge circuit reaches a predetermined level related to the light attenuation desired for alarm.

In practice, most light attenuation or projected beam smoke detection systems are used to protect large open areas and are installed with the light source at one end of the area to be protected and the receiver (photocell/relay assembly) at the other end. In some applications, the effective beam path length is increased by the use of mirrors. Projected beam detectors are generally installed close to the ceiling, where the earliest detection is possible and false alarms resulting from inadvertent breaking of the beam are minimized.

Although most systems employ a long path length and separation of the light source and the receiver, there are spot-type detectors which operate by light attenuation. One such unit uses a 0.19-m (7.8-in.) light path with a sealed reference chamber and an open sampling chamber, each containing a photocell. Presence of smoke in the sampling chamber results in a voltage reduction from its selenium photocell, which is measured by a bridge circuit containing the photocell from the reference chamber (fig. 15).

There are several problems associated with projected beam detection. Since these devices are essentially line detectors, smoke must travel from the point of generation into the path of the light beam. This may take time and allow the fire to develop headway before the alarm is sounded. In addition, for large protected areas where long beam path lengths are necessary, considerable smoke must be generated in any small segment of the beam in order for sufficient attenuation to be achieved. Two common ways of increasing the sensitivity of the system are by the use of multiple beams or reflecting mirrors that would pass the beam through the smoke more than once. Finally, continuous exposure to light can damage or accelerate the aging of photocells, resulting in increased maintenance and possible system failure.

Scattering results when light strikes aerosol particles in suspension. Scattered light reaches its maximum intensity at an angle of about  $27^\circ$  from the path of the beam in both the forward and backward directions and the scattered light intensity is at a minimum in a direction perpendicular to the beam path. The intensity of scattered light is also related to particle size and the wavelength of the incident light. This intensity, as described by Rayleigh's theory for particles with diameters less than 0.1 times the wavelength of the incident light, is directly proportional to the square of the particle volume and inversely proportional to the fourth power of the wavelength. The theory of scattering for larger particles, from 0.1 to 4 times the wavelength of the incident light, has been defined by Mie. These theories of light scattering are valid only for isotropic spherical particles and are very complex. However, smoke particles from a fire consist of a nonhomogeneous

mixture of particles, which are often neither spherical nor isotropic, and scattering intensities must be determined empirically for each aerosol mixture.

Smoke detectors utilizing the scattering principle operate on the forward scattering of light which occurs when smoke particles enter a chamber or labyrinth. The presence of smoke will increase the forward scattering of light from 10 to 12 times, but the intensity of the scattered light will decrease as the angle between the beam path and the photocell increases beyond 27°. The photocells used in these detectors may be either photovoltaic, or photoresistive. Typical component configurations are shown in figure 16. These units are of the spot type and may be used as single station devices with self-contained power supply and alarm or as part of an integrated system with remote power supply, alarm, and zone-indicating hardware.

## FLAME DETECTION

### Types

Flame detectors optically sense either the ultraviolet (UV) or infrared (IR) radiation given off by flames or glowing embers. Flame detectors have the highest false alarm rate and the fastest detection times of any type of fire detector. Detection times for flame detectors are generally measured in milliseconds from fire ignition.

Flame detectors are generally only used in high hazard areas such as fuel loading platforms, industrial process areas, hyperbaric chambers, high ceiling areas, and any other areas with atmospheres in which explosions or very rapid fires may occur. Flame detectors are "line of sight" devices as they must be able to "see" the fire, and they are subject to being blocked by objects placed in front of them. However, the infrared type of flame detector has some capability for detecting radiation reflected from walls. In general, the use of flame detectors is restricted to "No Smoking" areas or anywhere where highly flammable materials are stored or used.

### Infrared Detectors

Infrared detectors basically consist of a filter and lens system to screen out unwanted wavelengths and focus the incoming energy on a photovoltaic or photoresistive cell sensitive to the infrared. Infrared radiation can be detected by any one of several photocells such as silicon, lead sulfide, indium arsenide, and lead selenide. The most commonly used are silicon and lead sulfide. These detectors can respond to either the total IR component of the flame alone or in combination with flame flicker in the frequency range of 5 to 30 Hz.

Interference from solar radiation in the infrared region can be a major problem in the use of infrared detectors receiving total IR radiation since the solar background intensity can be considerably larger than that of a flame signal from a small fire. This problem can be partially resolved by choosing filters which exclude all IR except in the 2.5 to 2.8  $\mu\text{m}$  and/or 4.2 to 4.5  $\mu\text{m}$  ranges. These represent absorption peaks for solar radiation due to the presence of CO<sub>2</sub> and water in the atmosphere. In cases where the detectors are to be used in locations shielded from the sun, such as in vaults, this

filtering is not necessary. Another approach to the solar interference problem is to employ two detection circuits. One circuit is sensitive to solar radiation in the 0.6 to 1.0  $\mu\text{m}$  range and is used to indicate the presence of sunlight. The second circuit is filtered to respond to wavelengths between 2 and 5  $\mu\text{m}$ . A signal from the solar sensor circuit can be used to block the output from the fire sensing cell, giving the detection unit the ability to discriminate against false alarms from solar sources. This is often referred to as a "two color" system. For most applications, flame flicker sensor circuits are preferred since the flicker or modulation characteristic of flaming combustion is not a component of either solar or man-made interference sources. This results in an improved signal-to-noise ratio. These detectors use frequency sensitive amplifiers whose inputs are tuned to respond to an alternating current signal in the flame flicker range (5 to 30 Hz).

Flame detectors are designed for volume supervision and may use either a fixed or scanning mode. The fixed units continuously observe a conical volume limited by the viewing angle of the lens system and the alarm threshold. The viewing angles range from 15 to 170° for typical commercial units. One scanning device has a 120-m (400 ft) range and uses a mirror rotating at 6 rpm through 360° horizontally with a 100° viewing angle. The mirror stops when a signal is received. To screen out transients, the unit alarms only if the signal persists for 15 sec.

There are also detectors of this type designed to respond to passing sparks or flame fronts in piping such as in textile mills. The detector looks for glowing lint fibers in air ducting, which might cause fires in the downstream filters. The detector turns on a water spray, which extinguishes the glowing fiber before it reaches the filter. Of course, these detectors would not contain the flicker circuit.

#### Ultraviolet Detectors

The ultraviolet component of flame radiation is also used for fire detection. The sensing element may be a solid state device such as silicon carbide or aluminum nitride, or a gas-filled tube in which the gas is ionized by UV radiation and becomes conductive, thus sounding the alarm. The operating wavelength range of UV detectors is in the 0.17 to 0.30  $\mu\text{m}$  region and in that region they are essentially insensitive to both sunlight and artificial light. The UV detectors are also volume detectors and have viewing angles from 90° or less to 180°.

The combination of UV-IR sensing has been applied to applications in aircraft and hyperbaric chamber fire protection. These complex devices alarm when there is a predetermined deviation from the prescribed ambient UV-IR discrimination level in conjunction with a signal from a continuous wire overheat detector, the analysis being performed by an onboard minicomputer.

#### SUBMICROMETER PARTICLE COUNTING DETECTORS

During the earliest stages of thermal decomposition, in the pyrolysis or precombustion stage, large numbers of submicrometer size particles are produced. These particles fall largely in the size range between 0.005 and 0.02  $\mu\text{m}$ . Although ambient conditions normally find such particles in

concentrations from several thousand per cubic centimeter in a rural area to several hundred thousand per cubic centimeter in an industrial area, the presence of an incipient fire can raise the submicrometer particle concentration sufficiently above the background levels to be used as a fire signal.

Condensation nuclei are liquid or solid submicrometer (0.001 to 0.1  $\mu\text{m}$ ) particles which can act as the nucleus for the formation of a water droplet. By use of an appropriate technique, submicrometer particles can be made to act as condensation nuclei on a one particle-one droplet basis, and the concentration of particles is measured by photoelectric methods. A mechanism for performing this function is shown schematically in figure 17. An air sample containing submicrometer particles is drawn through a humidifier where it is brought to 100 percent relative humidity. The sample then passes to an expansion chamber where the pressure is reduced with a vacuum pump. This causes condensation of water on the particles. The droplets quickly reach a size where they can scatter light. The dark field optical system in the chamber will allow light to reach the photomultiplier tube only when the water droplets are present to scatter light. The output voltage from the photomultiplier tube is directly proportional to the number of droplets (i.e., the number of condensation nuclei) present.

The system uses a mechanical valve and switching arrangement to allow sampling from up to 4 detection zones with as many as 10 sampling heads per zone. Each zone is sampled once per second for 15 sec. All four zones are sampled each minute. The system is nominally set to alarm at concentrations exceeding  $8 \times 10^{11}$  particles per cubic meter, although it is possible to select different thresholds for each zone depending on the background noise and the sensitivity required. It is also possible to have the sensitivity vary for conditions differing with time of day. The system design is such that, with the maximum sample travel distance from the most remote sampling head, fire will be detected within 2 min of the time the products of combustion first reach a sampling head.

## SELECTION OF DETECTORS

When laying out a fire detection system, the design engineer must keep in mind the operating characteristics of the individual detector type as they relate to the area protected. Such factors as type and quantity of fuel, possible ignition sources, ranges of ambient conditions, and value of the protected property are critical in the proper design of the system. Intelligent application of detection devices using such factors will result in the maximization of system performance. Table I is a summary of fire detector application criteria as they are discussed in this section.

Heat detectors have the lowest cost and false alarm rate but are the slowest in response. Since heat tends to dissipate fairly rapidly (for small fires), heat detectors are best applied in confined spaces, or directly over hazards where flaming fires could be expected. Heat detectors are generally installed on a grid pattern at either their recommended spacing schedule or at reduced spacing where beams or joists may impede the spread of the hot gas layer, for faster response. The operating temperature of a heat detector is usually selected at least 14  $^{\circ}\text{C}$  (25  $^{\circ}\text{F}$ ) above the maximum expected ambient temperature in the area protected. Pneumatic heat detection systems have a

device known as a "blower heater compensator," which is used to prevent false alarms due to the sharp initial heat from ceiling-mounted unit heaters.

Smoke detectors are higher in cost than heat detectors but are faster in responding to fires. Due to the greater sensitivity of these detectors, false alarms can be more frequent, especially if the detectors are not properly located. Smoke detectors do not have a specific space rating except for a 9-m (30-ft) maximum guide derived from the UL full-scale approval tests which they must pass. Grid type installation layouts are usually not used, since smoke travel is greatly affected by air currents in the protected area. Thus, smoke detectors are usually placed by engineering judgment based on prevailing conditions.

Since smoke does not dissipate as rapidly as heat, smoke detectors are better suited to the protection of large, open spaces than heat detectors. Smoke detectors are more subject to damage by corrosion, dust, and environmental extremes than the simpler heat detectors because smoke detectors contain electronic circuitry. They also consume power, so the number of smoke detectors which can be connected to a control unit may be limited by the power supply capability.

Photoelectric smoke detectors are particularly suitable where smoldering fires or fires involving low temperatures pyrolysis of PVC wire insulation may be expected. Ionization smoke detectors are particularly suitable where flaming fires involving any other materials would be the case. The particle counter detector responds to all particle sizes equally, so it may be used without regard to the type of fire expected. These systems, however, are fairly expensive and complex to install and maintain. The design and layout of the sampling tubes is critical and must be done by someone familiar with the equipment.

Flame detectors are extremely fast responding but will alarm to any source of radiation in their sensitivity range, so false alarm rates are high if they are improperly applied. Flame detectors are usually used in hyperbaric chambers and flammable material storage areas where no flames of any sort are allowable.

Flame detectors are "line of sight" devices, so care must be taken to ensure that they can "see" the entire protected area and that they will not be accidentally blocked by stacked material or equipment. Their sensitivity is a function of flame size and distance from the detector, and some detectors can be adjusted to ignore a small flame at floor level. Their cost is relatively high, but they are well suited for areas where explosive or flammable vapors or dusts are encountered as they are usually available in "explosion proof" housings.

## FIRE MODELS

Over the past decade, considerable progress has been made in understanding the processes of fire. While there is still much to be learned, the current understanding is such that fairly accurate predictions of the impact of a fire in a compartment can be made using computer simulation techniques. These fire models can predict the production and distribution of energy and mass within

a series of interconnected compartments over time, and the effect of exposure to these combustion products on occupants, equipment, and the structure itself. Thus, one possible use of these models is to evaluate the response of detection devices required to provide the desired level of safety to occupants or critical equipment without being so sensitive that excessive false alarms are experienced.

The concept of designing a detection system such that it responds prior to the fire reaching a specified energy release rate was recently introduced into the National Fire Protection Association Standard on Detection Devices (72E). Here, a model was used to develop a set of curves for detector activation as a function of installed spacing for various ceiling heights, fire growth rates, and detector characteristics (e.g., thermal time constant). The designer decides on a fire size (energy output) at activation for the anticipated fire within the protected space and determines the detector spacing necessary for the actual compartment ceiling height.

TABLE I. - SUMMARY OF DETECTOR APPLICATION CONSIDERATIONS

Detector type	Response speed	False alarm rate	Cost	Application
Heat	Slow	Low	Low	Confined spaces
Smoke	Fast	Medium	Medium	Open or confined spaces
Flame	Very fast	High	High	Flammable material storage
Particle	Fast	Medium	High	Open spaces - high value

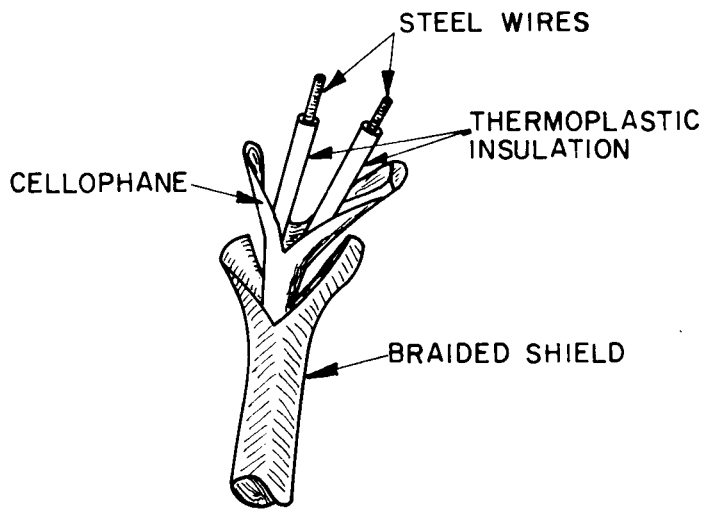

Figure 1. - Line-type fire detection cable using insulated parallel wires.

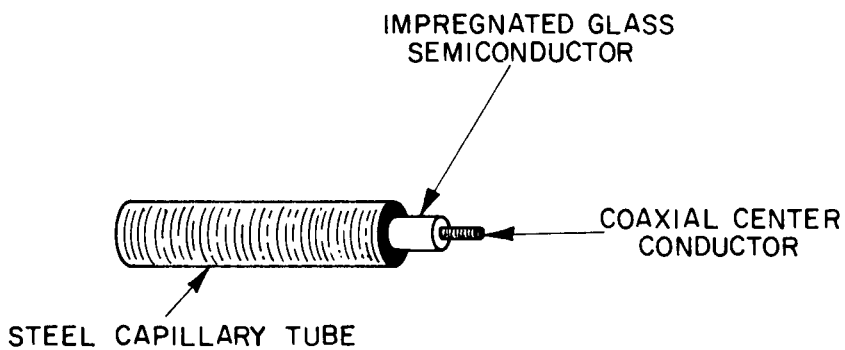

Figure 2. - Line-type fire detection cable using a glass semiconductor.



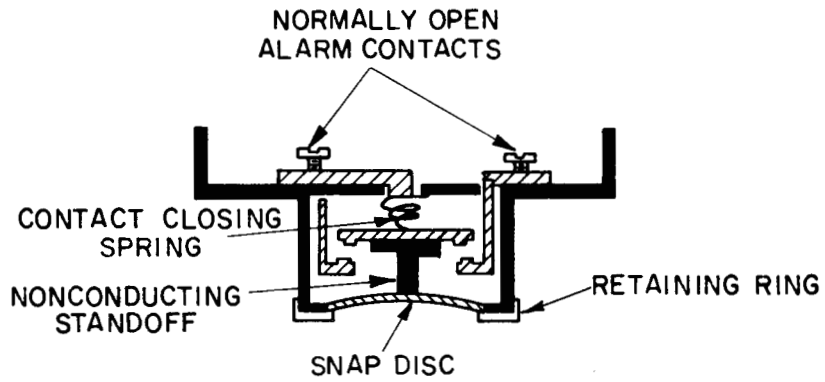

Figure 3. - Bimetal snap-disc heat detector.

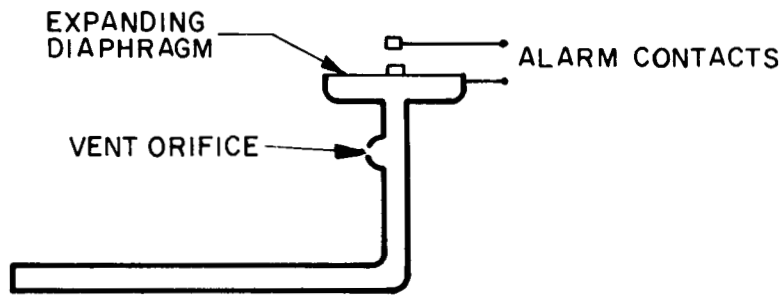

Figure 4. - Pneumatic-type heat detector.

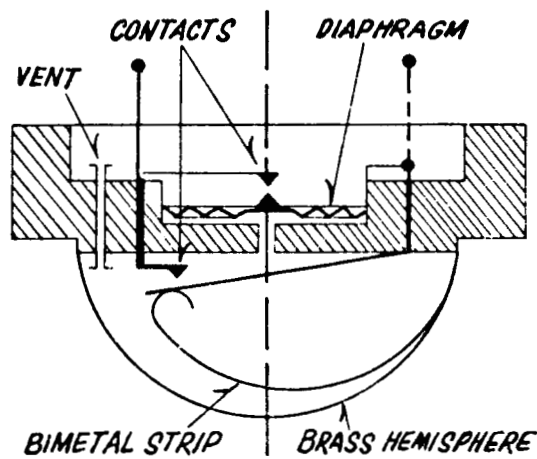

Figure 5. - Rate of rise fixed-temperature detector using a bimetal element.

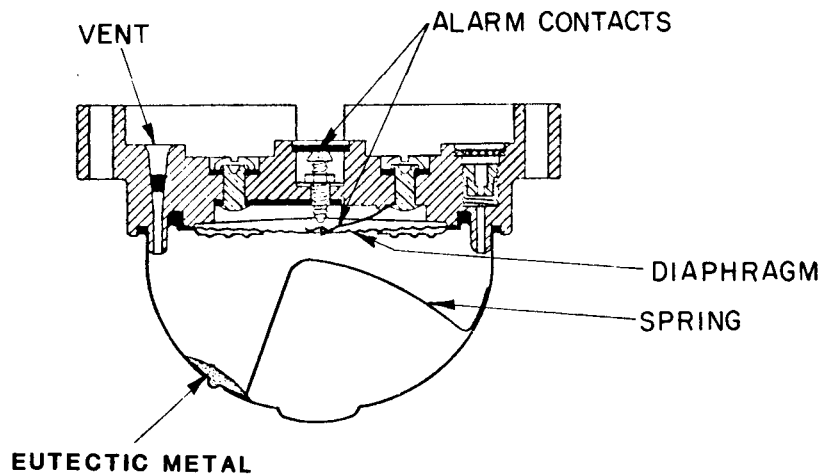

Figure 6. - Rate of rise fixed temperature detector using a eutectic metal.

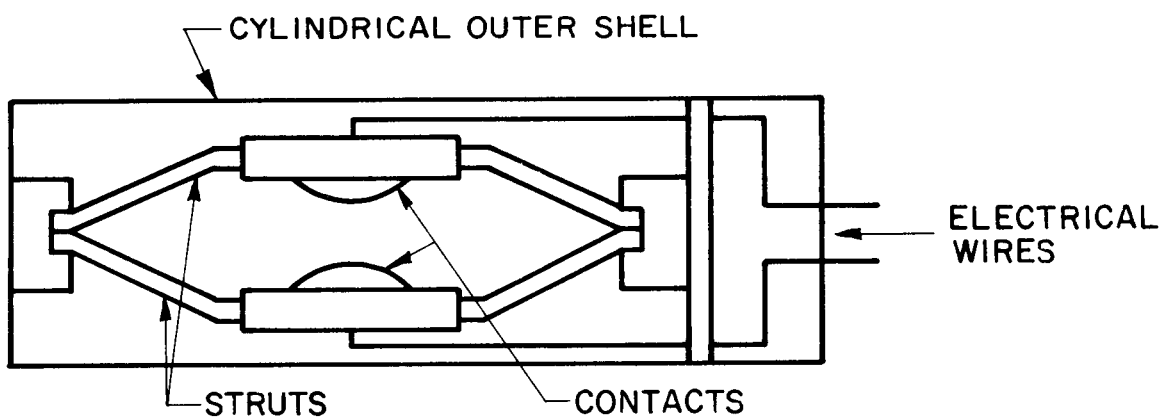

Figure 7. - Rate-compensation detector.

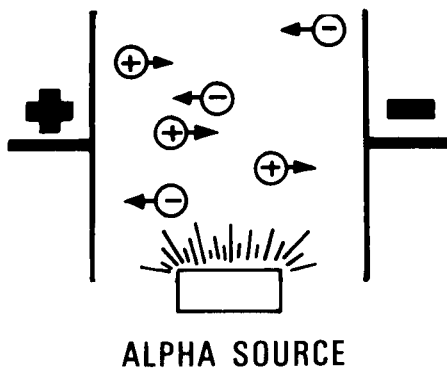

Figure 8. - Ionization of chamber air space.

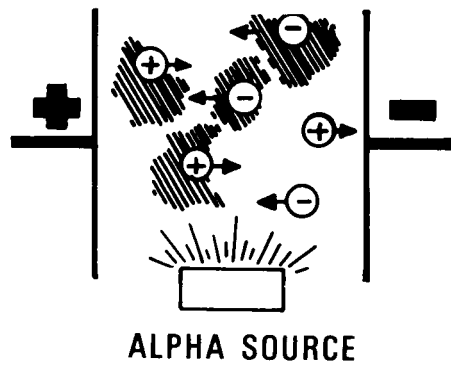

Figure 9. - Effect of aerosol in ionized chamber.

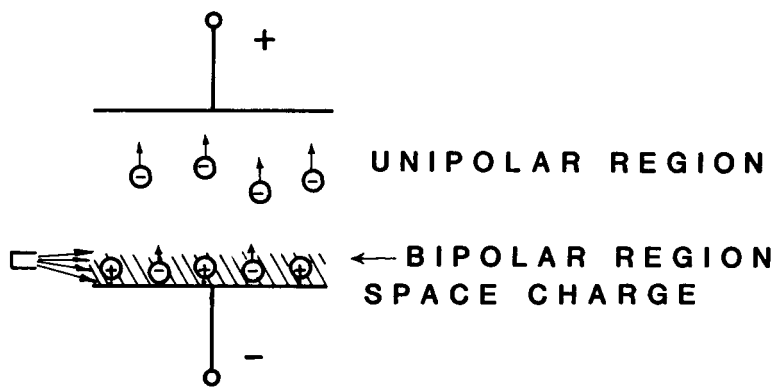

Figure 10. - Unipolar ion chamber.

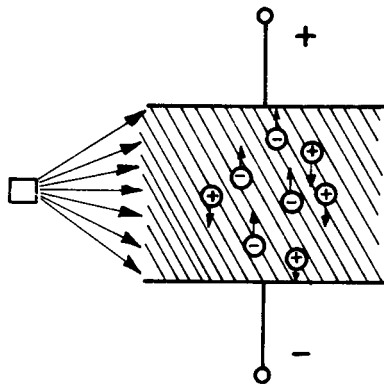

Figure 11. - Bipolar ion chamber.

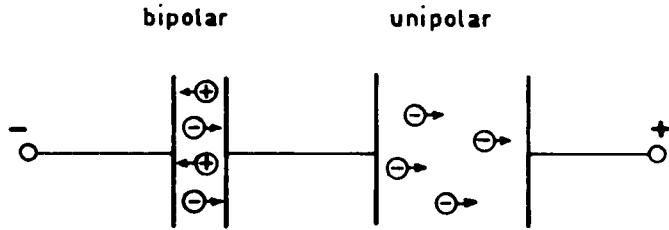

Figure 12. - Unipolar ion chamber consisting of theoretical unipolar and bipolar ion chambers in series.

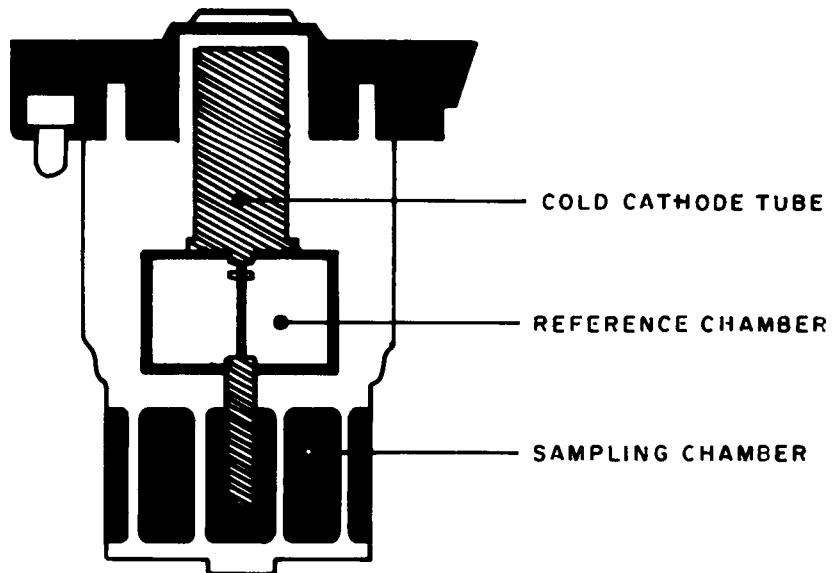

Figure 13. - Configuration of a dual ion chamber detector.

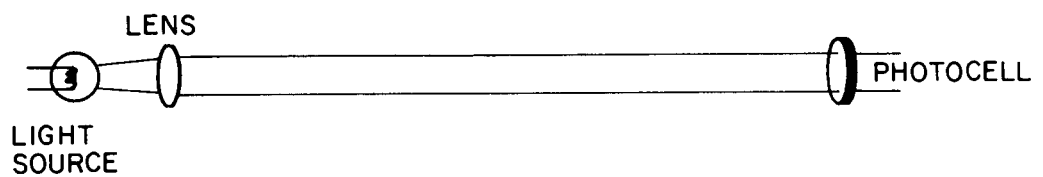

Figure 14. - Beam-type light attenuation smoke detector.

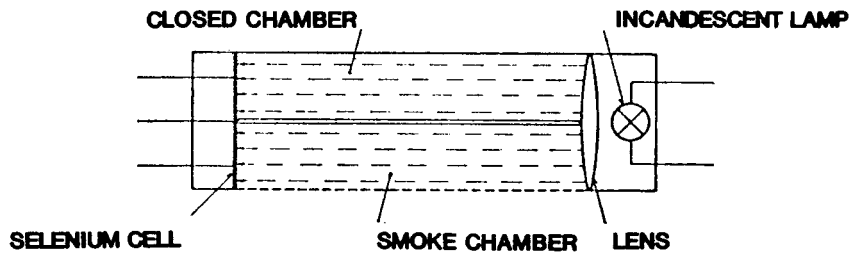

Figure 15. - Spot-type light attenuation smoke detector.

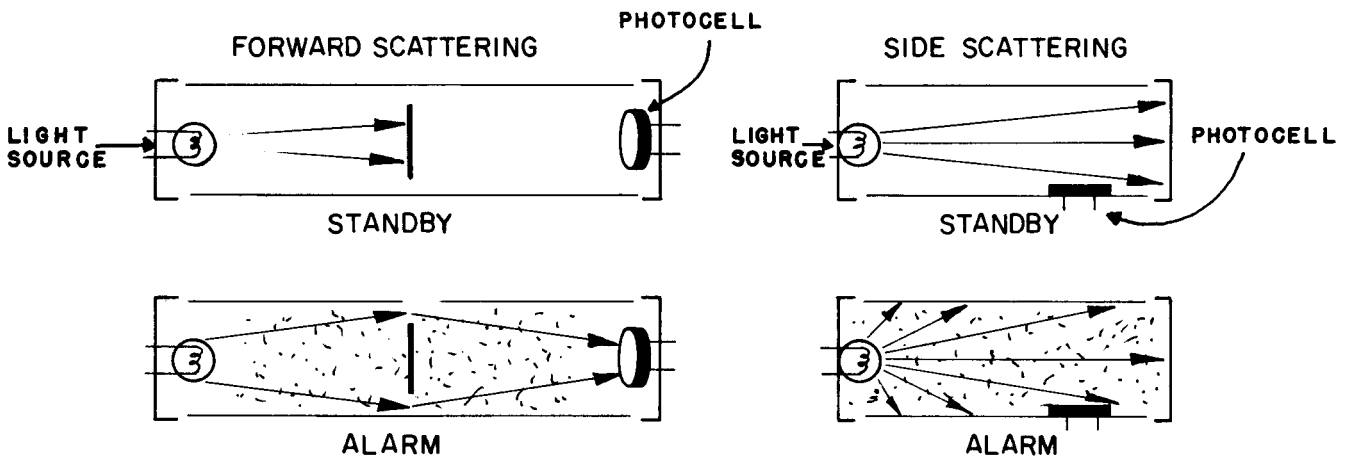

Figure 16. - Light-scattering smoke detectors.

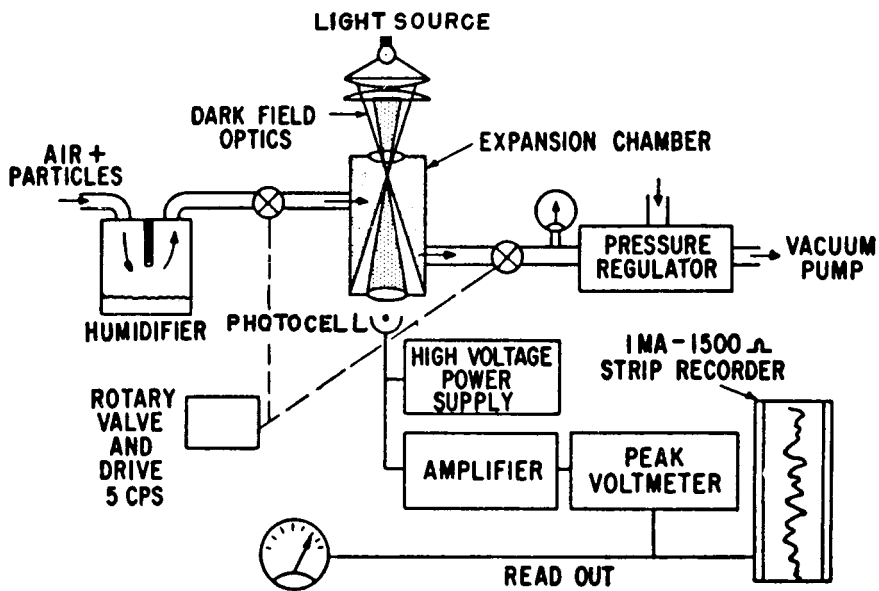

Figure 17. - Schematic of condensation nuclei particle detector.