

NOTICE

THIS DOCUMENT HAS BEEN REPRODUCED FROM
MICROFICHE. ALTHOUGH IT IS RECOGNIZED THAT
CERTAIN PORTIONS ARE ILLEGIBLE, IT IS BEING RELEASED
IN THE INTEREST OF MAKING AVAILABLE AS MUCH
INFORMATION AS POSSIBLE

LEGIBILITY NOTICE

A major purpose of the Technical Information Center is to provide the broadest dissemination possible of information contained in DOE's Research and Development Reports to business, industry, the academic community, and federal, state and local governments.

Although a small portion of this report is not reproducible, it is being made available to expedite the availability of information on the research discussed herein.

LNF-8704135-13



Lawrence Berkeley Laboratory

UNIVERSITY OF CALIFORNIA

Engineering Division

Presented at the Cryogenic Engineering Conference,
St. Charles, IL, June 15-18, 1987, and to be published
in Advances in Cryogenic Engineering, Vol. 33

Design Concepts for the ASTROMAG Cryogenic System

M.A. Green and S. Castles

June 1987



DISCLAIMER

This document was prepared as an account of work sponsored by the United States Government. Neither the United States Government nor any agency thereof, nor The Regents of the University of California, nor any of their employees, makes any warranty, express or implied, or assumes any legal liability or responsibility for the accuracy, completeness, or usefulness of any information, apparatus, product, or process disclosed, or represents that its use would not infringe privately owned rights. Reference herein to any specific commercial products, process, or service by its trade name, trademark, manufacturer, or otherwise, does not necessarily constitute or imply its endorsement, recommendation, or favoring by the United States Government or any agency thereof, or The Regents of the University of California. The views and opinions of authors expressed herein do not necessarily state or reflect those of the United States Government or any agency thereof or The Regents of the University of California and shall not be used for advertising or product endorsement purposes.

Lawrence Berkeley Laboratory is an equal opportunity employer.

DESIGN CONCEPTS FOR THE ASTROMAG CRYOGENIC SYSTEM

LBL--23822

M. A. Green

DE87 014683

Lawrence Berkeley Laboratory
University of California
Berkeley, California 94720

S. Castles

NASA/Goddard Space Flight Center
Greenbelt, Maryland

ABSTRACT

This paper describes the proposed cryogenic system used to cool the superconducting magnet for the Space Station based ASTROMAG Particle Astrophysics Facility. This 2-meter diameter superconducting magnet will be cooled using stored helium II. The paper presents a liquid helium storage concept which would permit cryogenic lifetimes of up to 3 years between refills. It is proposed that the superconducting coil be cooled using superfluid helium pumped by the thermomechanical effect. It is also proposed that the storage tank be resupplied with helium in orbit. A method for charging and discharging the magnet with minimum helium loss using split gas-cooled leads is discussed. A proposal to use a stirling cycle cryocooler to extend the storage life of the cryostat will also be presented.

THE ASTROMAG SUPERCONDUCTING MAGNET

The ASTROMAG experiment requires a magnetic field for charged particle detection, momentum resolution and energy resolution. The scientific capabilities of the ASTROMAG experiment depend on the size, shape and placement of the magnet coils. The coil configuration in turn strongly influences the cost and complexity of the facility. The magnet and cryogenic design presented in this paper represents a relatively simple magnet design concept which can be carried to the Space Station using the shuttle.

The design concept for the strawman magnet configuration for the ASTROMAG Particle Astrophysics Facility has the following characteristics:^{1,2}

- 1) The magnet coils are designed as relatively high-current coils which operate at stored magnetic energies approaching 20 MJ. The coils are designed so that the ratio of stored energy to active coil mass is about 15 J per gram of active coil mass. About 1/3 of

MASTER

MS
DATE OF THIS DOCUMENT IS UNLIMITED

the overall magnet system mass is expected to be active coil mass. The coils are arranged so that the net magnetic dipole moment is zero. The field drops to earth's field about 20 meters from the center of the magnet.

- 2) The magnet coils are to be located outside of the helium storage tank. This permits the physics experiment to be brought close to the coil package. (The goal is to put the closest detector about 10 centimeters from the coil package.) In addition, the stored magnetic energy which is dumped into the coils during a quench can be decoupled from the liquid helium in the storage tank allowing it to be cooled back down with helium vapor after it quenches.
- 3) The strawman design calls for spherical or near spherical tankage for the liquid helium. This will minimize the tank mass for a given stored helium volume and tank pressure rating; also, the surface to volume ratio is favorable. The difficulty with such a tank is the added complexity of the superinsulation system.
- 4) The magnet cryostat vessel will have dished, inward facing heads at the ends to permit the detectors to be brought close to the coil ends without the weight penalty associated with flat or near flat heads. The outside surface of the cryostat would be cylindrical near the coil and conical over the central helium tank. This increases the room inside the cryostat for cold mass supports, vapor-cooled shields and intercepts and a possible helium refrigerator thermal strap for the outermost shield and intercept.
- 5) The magnet, which will have a persistent switch, will be powered through vapor-cooled retractable leads. These leads will be part of the vapor-cooled shield and intercept circuit. This concept permits one to maximize the charging efficiency of the magnet. The lead current will be high enough to permit the coil to charge and discharge at a reasonable rate, and the voltages within the coil will be acceptably low during a quench. (See Table 1)

Table 1 presents some basic parameters for a high-current density version of the 2-coil HEAO-type magnet proposed as a strawman configuration for ASTROMAG. The location of the magnet coils with respect to the helium storage tank and the outer vessel is shown in Figure 1.

It is proposed that the magnet coils be cooled from the liquid helium storage tank by circulating the helium through tubes built into the coil packages. Helium II from the storage tank at 1.6 to 1.8 K will be circulated through the coils using a thermomechanical (fountain effect) pump.

THE MAGNET HELIUM II CRYOGENIC SYSTEM

The helium storage tank will be spherical with attached support rings. The magnet coil packages are attached to these support rings which also mate with the cold mass support system. A schematic representation of the cold mass is shown in Figure 1. As shown, the coil packages have 8 tubular struts between them to carry the 4.405×10^5 N (44.9 metric tons) tensile force between the coils. These struts connect the coils to the helium tank. It is proposed that the struts be made from low thermal conductivity MP-35 N steel to thermally isolate the coils from the helium tank. This isolation allows a thermally efficient recovery from a magnet quench.

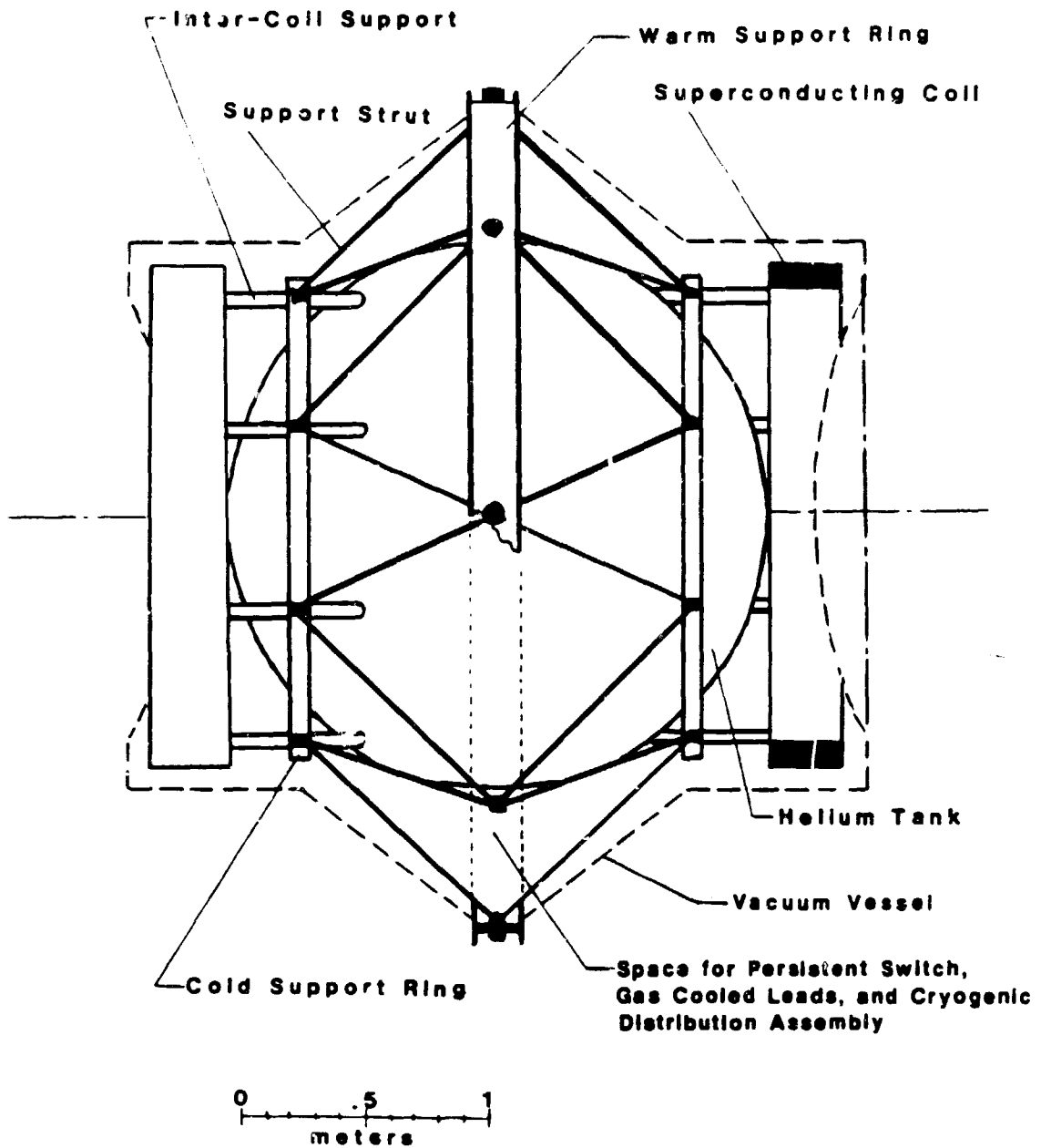

XBL 876-2580

Figure 1. A schematic representation of the ASTROMAG cryostat showing the coils, the helium tank, the support struts and the vacuum vessel.

The ASTROMAG spherical cryogen tank has an outside diameter of 2.2 meters. The thickness of the tank would normally be determined by the magnet stored energy. If the magnet coils are thermally isolated from the helium tank, the helium tank thickness is determined by the 1 atm external pressure which is applied during leak testing. The helium tank can contain 4,600 liters of helium (almost 700 kg of helium at 1.8 K) with an additional 15 percent of the tank volume as ullage.

Table 1. Strawman Magnet Parameters

| | |
|---|--|
| Number of coils | 2 |
| Coil outside diameter | 2.0 m |
| Coil separation | 2.2 m |
| Number turns | 6400 |
| Design current | 754 A |
| Peak field in coil | 6.25 T |
| Coupling between coil and secondary | > 0.92 |
| Magnet inductance | 66.9 H |
| Magnet stored energy | 19.0 MJ |
| Current density in s/c plus matrix | $2.985 \times 10^8 \text{ A m}^{-2}$ |
| EJ ² limit | $1.69 \times 10^{24} \text{ J A}^2 \text{ m}^{-4}$ |
| Magnet coil cold mass | 1500 kg |
| Magnet active cold mass | 1300 kg |
| Stored energy to active cold mass ratio | 14.6 J g ⁻¹ |
| Overall cold mass (including helium) | 2650 kg |
| Overall magnet mass | 4000 kg |

The largest single heat leak into the helium vessel is through the cold mass support system. The heat leak into the helium vessel through an ideal cold mass support system (where there is enough room for the support rods and their end terminations) is proportional to the cold mass, the design resonant frequency squared and the integrated temperature function Γ (Γ is defined as the integral of thermal conductivity with temperature from the lowest intercept temperature to the helium vessel temperature). The heat leak through the support straps into the vessel is inversely proportional to the elastic modulus of the support strap in the direction of force. The support rod material of choice is one with the lowest value of Γ divided by the elastic modulus. Oriented fiberglass epoxy is among the best materials which can be used for cold mass supports. It is proposed that this material be used in the form of tension straps with 2 thermal intercept points on them. The support strap configuration shown in Figure 1 consists of 32 straps arranged so that the magnet cryostat is self-centering during cooldown. The major design problem with support systems is minimizing deflections at the tank and on the outside support ring as the support system is loaded. The deflections are kept small so that a support system resonant frequency above 35 Hz is obtained.

Figure 2 is a schematic diagram of the ASTROMAG cryogenic system. Cold valves, cold burst discs and crossover plumbing associated with ground operations and shuttle safety requirements have been omitted to provide a clear exposition of the cryogenic system associated with the magnets and magnet leads. Figure 2 shows one of the 2 methods being investigated for circulating helium through the coils and the persistent switch using a thermomechanical effect pump.^{3,4} Figure 2 also shows how the boil-off gas is used to cool the retractable gas-cooled 750 A electrical leads, the shields and heat intercepts on the cold mass supports. The shield-intercept flow design for the ASTROMAG magnet cryostat is similar to the 2-shield HEAO long-life cryostat built and tested during the early 1970's.⁵ This cryostat demonstrated that helium could be stored within a tank with a magnet for up to 2 years.

The HEAO design intercepted heat from the 100 A current leads on the pipe leading from the tank to the first shield. The ASTROMAG cryostat design calls for enhanced heat transfer leads split into

2 parts.⁶ The warm end can be disconnected from the cold end. The cold end will be permanently connected to the magnet, helium vessel and persistent switch. After the gas leaves the cold part of the retractable lead, it passes through the 2 gas-cooled shields and support intercepts to the warm retractable part of the gas-cooled lead system. This configuration will result in increased efficiency during charging and discharging because shields and intercepts will be cooled while there is increased flow through the leads. As a result, the boil-off from the helium tank will be reduced for a considerable time after the magnet has been charged or discharged.

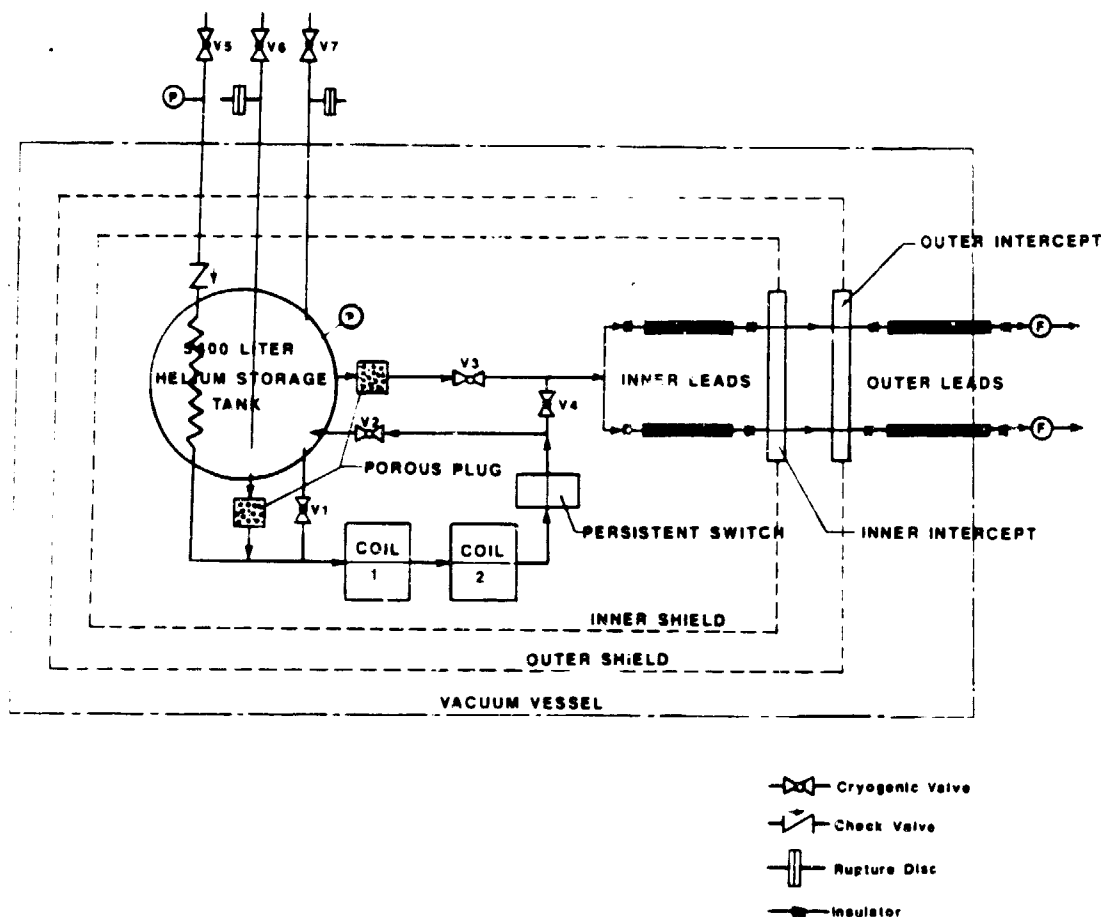

XBL 876-2577

Figure 2. A schematic diagram of the ASTROMAG cryogenic system. (The arrows show the flow through the coil driven by a simple thermomechanical pump. The arrows also show gas flow through the leads and intercepts. The shields are cooled by conduction.)

The 750 A gas-cooled leads proposed for the ASTROMAG magnet can operate within the vacuum vessel in any orientation.⁶ The leads would be connected to the gas side of the porous plug. The leads can carry the full cooldown gas flow with a relatively low pressure drop. The leads are designed to withstand high temperature so that they can operate for a long time without gas flow.

In a 2-shield cryogenic system, the most important part of the insulation lies outside the outer shield. It is proposed that 100 to 120 layers of multi-layer insulation be used outside the warm shield. This insulation must be applied very carefully, because it is important that the heat load to the first shield be minimized. The insulation between the outer and inner shield can be reduced to 40 or 50 layers. Inside the inner shield only 2 layers of heavy foil are required outside the foam layer on the helium tank. The layer of foam is a safety feature to reduce the influx of heat to the helium vessel should the vacuum tank be ruptured. The addition of a third shield cooled by a 50 to 70 K refrigerator has been studied for use on the Space Station. This refrigerated shield could increase the useful life of the ASTROMAG cryostat from 2 years to 3 1/2 years, thus reducing the need for helium resupply.

When the 2 shields are used alone, the estimated heat leak into the ASTROMAG magnet cryostat is 0.24 W (about half is through the cold mass supports). Helium would be boiled off at the rate of 0.0103 gs^{-1} (325 kg per year). When the leads are connected and the magnet is charged, the estimated heat leak goes up to 3.0 W (including a 1.0 W heat load due to charging the magnet at the rate of 250 A hr^{-1}). The integrated helium usage for 4 magnet charges and discharges per year (3 hours per charge or discharge) is estimated to be under 3 kg of helium per year.

The cryogenic system shown in Figure 2 is designed so that the magnet coils can be cooled down (in the event of a quench) using helium from the storage tank (about 75 kg of helium is required). The helium storage tank and magnet coils can be cooled down from room temperature using liquid helium pumped from a large storage tank through the ASTROMAG storage tank, the coils, the leads and shields.⁷

The strawman ASTROMAG magnet will have a vacuum vessel outside of the superinsulation and shield system. This vacuum vessel permits the magnet system to be tested on the ground, and it separates the gas which might be in the physics detectors from the insulation system. The outer vacuum vessel has a central support ring which connects to the shuttle. Conical-cylindrical vessels carry the pressure loading from 1 atm outside the vessel. The ends of the vacuum vessel consist of lightweight dished spherical heads (with a radius of curvature of 3 meters). These heads (dished inward) permit the physics detectors to be brought to a distance of 10 centimeters from the coil package. The central support ring transmits forces from the cold mass supports to the shuttle.

The projected magnet system cold mass including a pair of 750 kg coils, a persistent switch, the tank and 700 kg of helium is 2650 kg. An aluminum vacuum vessel plus the shields is estimated to have a mass of 1350 kg. (The use of composite structures could reduce the vacuum vessel mass further.)

CRYOGENIC SAFETY

The ASTROMAG cryogenic system will be designed to meet the shuttle and Space Station safety requirements. Specifically, the requirements of Mil Standard 1522 will be satisfied. The major safety requirements to be met are as follows:

1. The dewar will be two-failure tolerant. To meet this requirement, the cryogen tank will incorporate 3 independent, high-flow rate vent lines.

2. An engineering model cryogen tank will be proof pressure tested.
3. Fracture critical parts will be dye penetrant inspected.
4. The cryogen tank and plumbing system will be capable of withstanding a catastrophic loss of dewar guard vacuum.

The dewars being flown on the Superfluid Helium On Orbit Transfer Flight Demonstration⁸ meet these requirements and provide heritage for the design of the ASTROMAG cryogenic system.

SUMMARY

The ASTROMAG cryogenic system for the superconducting magnet has two features not found in ballon magnet cryostats or in previous designs for space-borne cryostats. First, the superconducting magnet coils are thermally isolated from the helium tank so that the coil can be recooled after a magnet quench. Secondly, circulation through the magnet coil is a thermomechanical effect pump which has no moving parts, and it should be very reliable. The projected life for the helium system is over 2 years. This life can be extended to 3 1/2-years by adding a third shield and intercept which is cooled by a small stirling cycle refrigerator.

ACKNOWLEDGMENTS

This research is supported by the Office of Astrophysics, NASA, and the Office of Basic Energy Science, U.S. Department of Energy, under Contract Number DE-AC03-76SF00098.

REFERENCES

1. Interim Report of the ASTROMAG Definition Team on the Particle Astrophysics Magnet Facility ASTROMAG (1986).
2. M.A. Green, et al, ASTROMAG: A Superconducting Particle Astrophysics Magnet Facility for the Space Station, to be published in the IEEE Transactions on Magnetics MAG-23 (1987).
3. M.D. Pirro and S. Castles, "Superfluid Helium Transfer Flight Demonstration Using the Thermomechanical Effect", Cryogenics 26 (1986), p. 84.
4. A. Hofmann, et al, "Considerations on Magnet Design Based on Forced Flow of Helium II in Internally Cooled Cables", Intor-Report (1986).
5. W.L. Pope, et al, "Superconducting Magnet and Cryostat for a Space Application", Advances in Cryogenic Engineering 20 (1974), p. 47.
6. R.G. Smits, et al, "Gas-Cooled Electrical Lead for Use on Forced Cooled Superconducting Magnets", Advances in Cryogenic Engineering 27 (1981).
7. M.A. Green, et al, "The Operation of a Forced Two-Phase Cooling System on a Large Superconducting Magnet", Proceedings of ICEC-8, Genova, p. 72 (1980).
8. M. DiPirro and P. Kittel, "The Superfluid Helium On Orbit Transfer (SHOOT) Flight Demonstration", to be published in Advances in Cryogenic Engineering 33 (1987).

END

DATE FILMED

11

/

10

/

87