

NASA Conference Publication 2479

Controlled Ecological Life Support System

Design, Development, and Use of a Ground-Based Plant Growth Module

Edited by

Robert D. MacElroy
*NASA Ames Research Center
Moffett Field, California*

David T. Smernoff
*University of New Hampshire
Durham, New Hampshire*

John D. Rummel
*NASA Ames Research Center
Moffett Field, California*

NASA

**National Aeronautics
and Space Administration
Ames Research Center
Moffett Field, California 94035**

1987

Foreword

Soon after the CELSS program research activities began in the early 1980's, the Principal Investigators in the Food Production group realized the importance of experimentally subjecting crop plants of interest to a ground-based verification of flight environments. It was decided that a meeting of Principal Investigators and NASA scientists and engineers could begin to define requirements for experimentation, and for equipment leading not only to the eventual design of an extraterrestrial CELSS but also to the implementation of prefatory flight experiments requiring system isolation from a Shuttle or Space Station crew environment. Accordingly, a workshop was convened at Ames Research Center in the fall of 1984 with that intention. The proceedings are reported in Section II, entitled "Controlled Ecological Life Support Systems: Development of a Plant Growth Module". The scientific and technical disciplines represented are reflected by the subjects covered and the list of attendees.

Section III, titled "Plant Growth Module (PGM) - Conceptual Design" is the response to the requirements generated by the workshop. It offers different concepts of an experimental enclosure and designs for the many supporting subsystems. This section provides a framework upon which the final design of laboratory-sized plant growth chambers can be based.

Within this approximate time period, the decision was made to construct and use, at Kennedy Space Center with PI support, a large chamber to attempt to duplicate on a scaled-up mode laboratory plant production results - incorporating eventually waste management and food processing systems also. The difference between the Breadboard Project facility, and the equipment proposed for assembly at Ames lies principally in size and degree of closure, the small Ames system to be tightly closed, controlled, and monitored.

Section I is the report of a spring, 1986 meeting of CELSS scientists and plant production Principal Investigators. The purpose of this meeting was different from that of the meeting of September, 1984, in that the extramural scientists were asked how best their scientific questions, based now also upon their laboratory experience over the intervening time period, could be addressed, and whether a cooperative effort with Ames scientists and engineers would be advantageous. They were asked too to confirm the experimental requirements expressed in the previous meeting. This report (CELSS Program Meeting, Carmel Valley Inn) summarizes the major science issues discussed and proposed approaches to addressing them. The primary result of the meeting was a consensus that certain scientific questions will best be addressed by assembling and operating a set of plant growth chambers at Ames with extensive interactive and cooperative use by both in-house and extramural investigators.

The plant experiment equipment that has been identified in Section I is appropriate for addressing a series of unanswered questions about the influence of the environment on higher plant growth, and can serve the CELSS program in several capacities. It will be able to mimic the environment of the large Breadboard project chamber at KSC and thus serve as venue for experimental evaluation of problems identified in the large scale system. It will serve to identify, through a sequence of experiments conducted by a consortium of scientists, issues associated with the isolation of the plant growth environment, such as the effect of the accumulation of plant volatiles, the efficacy of maintaining separate root and shoot gas environments, the application of novel light distribution systems, and others. It will provide an opportunity to establish baseline data for the study of plant growth during flight experiments. Finally, it will provide a system for the evaluation of equipment and techniques, and will serve an essential role during the A and B phases of flight experiment development.

Robert D. MacElroy
John W. Tremor

April 1987

N88 - 13853

-- SECTION I: --

CELSS PROGRAM MEETING

John W. Tremor and Robert D. MacElroy

CARMEL VALLEY INN

APR. 23-25, 1986

TABLE OF CONTENTS

FOREWORD v
Robert D. MacElroy and John W. Tremor

SECTION I:

CELSS PROGRAM MEETING

John W. Tremor and Robert D. MacElroy

INTRODUCTION..... 1
PROCEEDINGS..... 2
VOLATILES AND SOLUBLE ORGANICS, MICROBIAL ACTIVITY,
DISEASE, AND PRODUCTIVITY..... 3
NUTRIENT DELIVERY SYSTEMS..... 5
LIGHTING SYSTEM..... 6
FLIGHT EXPERIMENTS..... 7
PLANT GROWTH MODULE DOCUMENTATION..... 7
APPROACHES AND MECHANISMS..... 7

SECTION II:

CONTROLLED ECOLOGICAL LIFE SUPPORT SYSTEMS:
DEVELOPMENT OF A PLANT GROWTH MODULE

Editors: Mel M. Averner, Robert D. MacElroy
and David T. Smernoff

INTRODUCTION..... 11
IRRADIATION..... 12
AIR FLOW..... 15
PLANTING AND HARVESTING..... 18
CARBON DIOXIDE..... 21

PRECEDING PAGE BLANK NOT FILMED

TEMPERATURE AND RELATIVE HUMIDITY.....	23
OXYGEN.....	25
CONSTRUCTION MATERIALS AND ACCESS.....	26
VOLATILE COMPOUNDS.....	29
BACTERIA, STERILIZATION, AND FILTRATION.....	31
NUTRIENT APPLICATION SYSTEMS.....	34
NUTRIENT MONITORING.....	37
NUTRIENT pH AND CONDUCTIVITY.....	39

SECTION III:

PLANT GROWTH MODULE (PGM), CONCEPTUAL DESIGN

Steven H. Schwartzkopf and Daryl Rasmussen

INTRODUCTION.....	41
REQUIREMENTS.....	42
DESIGN.....	45
HARDWARE DEVELOPMENT PLAN.....	70

APPENDIX

LIST OF ATTENDEES, AMES PGM WORKSHOP.....	71
CELSS BIBLIOGRAPHY.....	73

INTRODUCTION

During the spring of 1986, the CELSS program observed several important milestones. The first was the agreement by Ames Research Center to accept responsibility for overseeing and conducting CELSS program science. A second was the recognition by the National Commission on Space that bioregenerative life support should be promoted within NASA. The third was the decision by the NASA Headquarters Life Sciences Division to seek additional support (via a funds augmentation) specifically for the continued development of the CELSS Breadboard project at Kennedy Space Center.

Meanwhile, the CELSS program had undergone formal critique by a subcommittee of the Life Sciences Advisory Committee (LSAC). That committee underlined the importance of continued emphasis within the program on the scientific aspects of CELSS. The program also had been reviewed by a subcommittee of the National Academy of Sciences Space Sciences Board (SSB), and there are strong indications that the SSB report, when released, will support the goals of the CELSS program.

The renewed attention to CELSS science prompted consideration of ways in which Ames Research Center could promote the goals of the CELSS program within its institutional constraints. The decision was made to bring together, in a relatively small, interacting group, the scientists within the CELSS program whose expertise is in the growth of higher plants. These scientists were then asked whether it would be useful for Ames to play a role in promoting their work and that of the program as a whole. The ground rules for the discussion were that any work undertaken by ARC would:

- 1) Not compete with work presently anticipated at universities, in industry, or in connection with the KSC Breadboard project,
- 2) Complement and extend research efforts at universities and industry, and
- 3) Support and complement work planned for the Breadboard project.

The decision to consult first with plant scientists was made because the concept of a CELSS usable in space depends heavily on attaining high production rates by vascular plants. It is anticipated that interactions with scientists in other parts of the program will be useful in the future. Although Ames itself lacks expertise in plant physiology and crop production, its potential contributions in such areas as chemical analysis,

automation, computational equipment, data collection and analysis, shop construction facilities, and physical laboratory space can complement the plant science expertise that could be contributed by university scientists.

The goal of the meeting was to draw upon the accumulated experience and knowledge of those Principal Investigators who have been working on CELSS-related problems for a number of years. Many basic questions already have been experimentally addressed by these scientists, allowing them and other attendees to formulate specific sets of inquiries. The PIs were asked to identify the critical science problems inherent in maintaining high plant productivity and crop yield in closed life support systems, and to identify the priority with which those problems should be attacked. They were then asked to project the analytical techniques and technology required in approaching those critical questions. It was anticipated that discussions would bring out problems of mutual interest which could be most effectively addressed by an experimentally active team that would combine Ames' capabilities with a committed group of Principal Investigators. In achieving these intentions, this meeting was gratifyingly successful.

PROCEEDINGS

An informal yet intensive meeting was convened over 2 1/2 days (April 23-25, 1986) at the Carmel Valley Inn, Carmel Valley, California. The following scientists were in attendance:

Ray Huffaker - University of California at Davis
Robert MacElroy - Ames Research Center
Cary Mitchell - Purdue University
David Raper - North Carolina State University
John Rummel - Ames Research Center
Frank Salisbury - Utah State University
Stephen Schwartzkopf - University of California at Davis
David Smernoff - University of New Hampshire
Theodore Tibbitts - University of Wisconsin, Madison
John Tremor - University of New Hampshire

Dr. MacElroy, manager and monitor of the Ames CELSS-related work, served as host and moderator of the meeting. He opened with a discussion of the current state of the program and an evaluation of its future. He also described Ames' capabilities related to supporting a CELSS science effort, including development of flight experiments. While pointing out that any such work at Ames necessarily would be complementary to university or industry studies and to KSC's CELSS Breadboard Facility (CBF), he posed the questions:

Can Ames and a consortium of investigators who are experts on higher-plant growth be useful in promoting the goals of the CELSS program by extending the capabilities of the individual investigators?

Can such a combination be assembled to produce important and necessary scientific research results for the CELSS program?

In asking these questions, Dr. MacElroy emphasized the essential nature of the support and direct involvement of the investigators. He explained that the role of Ames would be to respond to the scientific requirements of those investigators for the development of the necessary equipment for experimentation and for supporting the conduct of those experiments.

The meeting was opened to discussion. The subject and direction of the interchange varied considerably, but was first directed toward identifying research areas that were not being, or could not be, effectively addressed by the present principal investigators. Second, an attempt was made to select from the research areas identified those that could be undertaken by Ames and to outline the scope of that research. And third, mechanisms of research proposal development and personnel involvement were considered. The following is a summary of these discussions.

Volatiles and Soluble Organics, Microbial Activity, Disease, and Productivity

The participants emphasized the need to know more about the consequences of closure on the growth of plants. Specifically, plants in an atmosphere-closed system are expected to produce volatile organics, and these organics will likely accumulate. Some of these volatile compounds may have specific or general effects on plant productivity or on human occupants of a CELSS. While it may be possible to remove such materials by filtration through activated charcoal or by incineration, the effect of the volatiles on plants is unknown and should be determined. A similar situation exists for the nutrient delivery system, but in that case it also is true that many species of bacteria also will accumulate along with water-soluble organics. The identities and effects of soluble organics are not known. The concern for closure at this stage in the development of CELSS was felt to center more on the need for "non-leaking" chambers than on the problems associated with the total recycling of elements.

Another major environmental factor that may impact productivity, and that is not being adequately addressed by the PIs and probably will not be experimentally treated by the CBF, is microbial activity, particularly in the recycling nutrient solution. Since microbial control is a major problem in open hydroponic systems, it is assumed that in a closed system it will

also be significant. Very little presently is known about microbial population-dynamics, community stability, nutrient competition, the dynamics of the nitrogen cycle, potential microbial pathogenicity, or how populations might be optimized to the benefit of higher plants. Russian experiments have demonstrated that the microbial interaction with a closed environment is dynamic. A large number of species are involved, the species mix is changing with time and their numbers are related to the life cycle of the plant and to the health of the crop. Further, some of the genera can be circumstantially pathogenic in man; the health implications of a closed environment, with its concomitant volatile organic and microbe constituents, is largely unknown.

It was mentioned that higher plant productivities are reaching a maximum in open systems. This brought up a list of related questions: Will productivity be comparable in closed systems? Will closure alter the reliability of production? What are the consequences of growth in a closed chamber to polyculture? Will the microbial load and species distribution change in significant ways as the system is removed from contact with the external environment, thus affecting productivity? What sizes of reservoirs are required, and to what extent will the accumulation of materials in the closed system affect the buffers? Are questions that have been raised about the stability of such a system well founded?

During this phase of the discussion it became obvious that well-controlled experiments to answer questions like these will require access to closed plant growth system. Moreover, it is likely that more than one chamber will be required. It was suggested that a minimum of three chambers will be needed, with each chamber capable of maintaining several plants of any one of the candidate species for a full crop production cycle. Ideally, such chambers should be available at the same time, but institutional support and budgetary considerations may dictate the fabrication and trouble-shooting of one unit first, with others closely following. The Principal Investigators expressed the concern that they have more than enough to do in their home laboratories without involving themselves directly in the development of closed chambers at ARC. These comments suggested the possibility that the necessary equipment might be constructed at Ames but used by all, as a complement to the efforts of the program and to the tasks of the individual investigators. In any case, the group felt strongly that closed chamber construction at Ames would be much more cost-effective and should ensure superior construction over having individual investigators design and construct closed chambers at each location.

Another clear advantage of constructing closed chambers at Ames would be the ability to provide research support to the CBF at Kennedy. If and when problems arise during CBF operations, closed, well-monitored units of known and controlled parameter

response and with a materials-accounting system, could be instrumental in sorting out the unknowns. Closed chambers at Ames would provide a valuable capability for problem solving that would be distinct from capabilities of the CBF.

An early goal of the program, then, would be to develop and standardize a unit and duplicates that could be constructed for use at Ames. Eventually, additional replicas of these chambers could be built for distribution to PI laboratories. In that way, experimental results gained at university laboratories could be directly compared within the context of the overall program.

Nutrient Delivery Systems

It was agreed that the problems associated with nutrient delivery were common to all CELSS higher plant work. It is an issue that the CBF project will likely never address in detail and something that Ames technology and analytic capability might be logically adapted to developing. Additionally, it is an issue whose study would benefit greatly from the combined experience of the PI's.

At the heart of the problem lies the lack of knowledge about how to maintain a stable, optimum nutrient system, how to precisely monitor and regulate the separate nutrients being supplied to the plants, and particularly, how to determine changes requiring regulation that may be needed as plants mature. Also, there is almost no information on how to monitor and control organic compounds that accumulate in the recirculating solutions. Different nutrient sources act in unpredicted ways (the responses of plants to different forms of nitrogen were discussed in some detail). Good control of nutrient application might significantly conserve the nutrients, prevent "luxury consumption", and even lead to an increased productivity and yield. Relationships between uncontrolled nutrient concentrations, the possible toxic consequences of luxury consumption (for human consumers), and attendant deleterious effects on yield also entered into this discussion. Root zone aeration, as a function of nutrient delivery rate, is another factor requiring attention in the development of a nutrient system.

The consensus was that nutrient control is as important as control of the enclosed atmosphere, and that both should be major research priorities. It was noted that work on the development of nutrient delivery systems, having continuous analysis and precise constituent control capability, could and should proceed independently of the development of a closed system. When completed, the nutrient systems would be integrated into the closed chambers and be made available to individual investigators (and possibly KSC) for integration into their growing units.

Lighting System

Although a unique role of Ames was not recognized for this area of research, it was agreed that increased knowledge and intelligent use of spectral effects might significantly enhance productivity. The group emphasized the need for expanded research into both unique means of directing light to plants (e.g., in-canopy lighting, light pipes, etc.) and developing improved irradiation sources (e.g., more efficient energy conversion and better spectral balance). The individual PIs would have neither the time nor the facilities for such studies, and a lighting system for a closed unit at Ames would be necessary as one of the controllable variables. It was also agreed that the CBF project would be unlikely to find a place in its schedule for this basic research. This research is not crucial to the development of a functional CELSS, but it is emphasized and felt to deserve attention because plant lighting currently demands the greatest power consumption of all CELSS components.

These three categories of experimental interest are not unique to any one plant species, although any specific application may be. In addition to these, other areas that might be a natural outcome of a combined effort at Ames were touched upon. They included work on definition of the reliability and stability of a closed CELSS, the development of models to enable increased control, the effects of a common environment on polyculture in closed chambers (and how polyculture might be accommodated), non-destructive growth monitoring, calibration and standardization, and automation and robotics.

Study of many of these issues could come much later in the gradual development of an experimental system. To paraphrase the words of one participant, an Ames/university coordinated effort will, by focusing on controlled systems and closed chamber units, provide an opportunity to extend findings from species to species in a standard system, provide a facility to coalesce different findings and interests, and provide a common ground for the principal investigators to interact with each other in a quantitative way.

Another advantage that was seen for this strategy was that Ames' involvement in the activity would result in a "research presence" that would attract and provide means for supporting guest investigators. In this connection, it was agreed that, at the appropriate times, the principal investigators or their laboratory representatives would work directly with equipment at Ames.

Flight Experiments

Dr. MacElroy outlined the potential flight opportunities, domestic and foreign, for CELSS-type experiments. In so doing, he distinguished between the requirements and involvement of the Space Biology program and the CELSS program. These two programs of course have many common interests, and it was suggested that the May 17 meeting with space biology and CELSS would provide a good forum to discuss these issues.

Plant Growth Module Documentation

In September, 1984, a workshop was convened at Ames to consider and prescribe scientific requirements for a closed Plant Growth Module similar to the closed chamber discussed here. One attendee at both meetings drew a distinction between the formerly-considered module and the closed chambers under current consideration. In keeping with the experimental mission envisioned for the chambers being considered at Carmel, it was thought reasonable to re-evaluate the original requirements. Therefore, attendees at the Carmel Valley meeting were asked to revisit the requirements for a generalized chamber in light of current discussion.

There was agreement that only cosmetic changes to the format of the report need be made - that the scientific requirements remained intact. It was agreed that a 2 to 3 m³ controlled and monitored chamber was of an effective size to provide adequate space for the crop species being studied and yet was small enough to allow manipulation and monitoring through arm ports in the side. It was suggested that an updated science requirements description could be made part of the present report, and that the final report should also include the conceptual chamber design developed at Ames in late 1984.

Approaches and Mechanisms

Discussion on the last day focussed on mechanisms of involvement between the Principal Investigators and Ames Research Center. There was agreement that a Consortium of Principal Investigators should be organized to direct and to participate in the development and experimental use of specific research apparatus at Ames: a 2 to 3 m³ sealed chamber and ancillary equipment.

In particular, this proposed chamber/system would, over the course of development, be comprised of a complex of parameter control, monitoring, and data collection devices, nutrient delivery and lighting systems. The design would allow for monitoring microbial population densities and changes, soluble or volatile organic material concentrations - in the atmosphere and

nutrient systems.

Over the course of this discussion, methods of forming the group and making it effective were addressed:

- 1) Recognition of the activities and goals of a Consortium could be formalized by the development of a Memorandum of Understanding between Ames and each of the involved universities.
- 2) Support for the research and required equipment was discussed. The approach that seemed most feasible and practical involves the joint preparation of a research proposal that describes the experimental use and appropriate design of such equipment within the context of an Ames/PI Consortium effort. The proposal would be submitted to NASA for peer review. Funding of the work could be through either existing research cooperative agreements or through other instruments to be decided later.

Some time was spent discussing the possible content of a proposal, how it might be coordinated, and ultimately managed upon implementation. It was suggested that the proposal should spell out the primary goals, the equipment needed, and the experiments that should be conducted. For example, a primary goal might be to compare biomass and food productivity of a crop in three chambers, one a closed system with no air or nutrients purification, one a closed system with controlled air and nutritional purification, and one an open system with frequent exchange of air and fresh nutrient solution. Frequent interaction would be anticipated from particular PIs with expertise in the specific crop under study at any particular time. Such an experiment with a single crop might constitute a milestone for each PI, and secondary goals could be prioritized.

The participants also believed that a coordinating PI should be identified in the proposal, and should be resident at Ames. Dr. Schwartzkopf was thought to be a strong candidate for that responsibility. A number of other candidates, of various degrees of availability or suitability, also were proposed and considered. At that point, one of those present observed, "you can't recruit without a proposal, and a contact at Ames is needed now to generate the proposal." Further discussion of a permanent coordinator was curtailed, and it was agreed that John Tremor would serve as the proposal coordinator.

In further consideration of what might go into the proposal, it was suggested that a first year effort might involve initial test work, of the kind projected above, with the existing small (single plant) chambers of Dr. Schwartzkopf. The second year of the proposed work could be used to complete and test the larger closed chambers, and the closed experiments could begin the third year. To complement this schedule it was suggested that the nutrient system be developed in parallel with the closed system.

In consideration of plans for future meetings, the observation was made more than once that an assemblage of no more than ten people was a very efficient size for a planning group. As such, it would be desirable to keep future meetings of the group at a similar scale. While the mix of disciplines would change as other researchers were called upon, the total number of people involved should remain about the same. It was also agreed that Dr. William Knott be included in future briefings and meetings to help secure the relationship between the CELSS efforts at Ames and at Kennedy.

The meeting ended with the promise that Ames would draft a report of the meeting for distribution and begin the process of building an acceptable Memorandum of Understanding. Ames personnel will submit the proposal for peer review. Plans were made to keep all concerned informed throughout the proposal development period, and perhaps to meet again before the proposal is submitted.

N88 - 13854

-- SECTION II: --

CONTROLLED ECOLOGICAL LIFE SUPPORT SYSTEMS:
DEVELOPMENT OF A PLANT GROWTH MODULE

Editors: Mel M. Averner, Robert D. MacElroy
and David T. Smernoff

AMES RESEARCH CENTER

SEPTEMBER 1984

PRECEDING PAGE BLANK NOT FILMED

INTRODUCTION

This section summarizes the results of a workshop held at NASA-Ames Research Center in September 1984. The purpose of the workshop was to begin definition of the scientific and technical requirements for the design and construction of a ground-based plant growth facility. The energy, mass, volume and cost considerations of the Plant Growth Module (PGM) are not included in this report, but are left for consideration by design engineers. Building on the previous work of the CELSS program, the attendees consolidated their thoughts on science design criteria for the PGM, and this section reports those considerations.

The PGM workshop served as the preliminary step in the design and construction of a functional plant growth module. The topics of discussion in the workshop covered the major design elements of the PGM. Individuals with expertise in each particular sub-area were invited to discuss and propose what they thought the requirements of those design elements should be. Decisions of each group were recorded and reported by the chairman. These reports were extensively reviewed by the members of the group and by CELSS program scientists. The results of the many meetings, discussions and reviews were then incorporated into this section, in the format that each of the chairmen considered most appropriate.

IRRADIATION

John Sager, Chair

I. Definition of parameters affecting plant growth.

A. Irradiance

Adjustable levels from 0 (visually dark) to 1000 micromole $s^{-1} m^{-2}$ with an operational range of 400-700 micromole $s^{-1} m^{-2}$ (90-160 $W m^{-2}$) measured at the top of the plant canopy. Levels greater than 1000 micromole $s^{-1} m^{-2}$ may be required for high CO_2 experiments. Adjustment of irradiance must be adapted to the specific lamp types used in the canopy. Options include the dimming systems available for HID and fluorescent lamps (for HID, Widelite Inc., San Marcos, TX; for fluorescent, CESI, Rockville, MD). Other less expensive options for irradiance control include the use of an absorbing screen to reduce radiation transmitted to the plants or symmetric reduction of lamp number -- applicable chiefly to fluorescent systems on the scale contemplated.

B. Spectral Distribution

Maximize photosynthetically-active radiation (PAR) based on the relative quantum efficiency of photosynthesis (McCree, K. J. 1972, Agric. Meteorol. 9:191-216) and the light energy utilization efficiency of photosynthesis from the various sources (Sager, J. C., J. L. Edwards, and W. H. Klein 1982, Transactions of the ASAE 25(6):1737-1746). In addition, the light provided must include far-red and UV portions of the spectrum and the spectrum must be balanced to achieve the desired physiological and morphological development of the particular species. Examples of such control include the germination of some seeds, such as Grand Rapids lettuce, which require a red irradiation. In this case far-red, and in some instances blue radiation, provides maximum inhibition of germination. Nonetheless, far-red promotes flowering in conjunction with photoperiod, and therefore must be provided. These effects can be attributed to phytochrome photo-equilibrium (the P_{fr}/P_{tot} ratio) during the photoperiod (Vince-Prue, D. 1975, Photoperiodism in Plants, McGraw-Hill). With these effects in mind, the spectral characteristics of the light source must be known from 250 nm through the thermal range (about 50 micrometers), with particular care given to limiting the radiant loading on the plants.

C. Spatial Distribution

Horizontal variation should be $\pm 10\%$ of irradiance over the plant canopy area. Vertical variation (lighting at the

IRRADIATION (cont.)

top of the growing canopy) should be $\pm 10\%$ for the life of a crop or during the course of an experiment. Vertical variation might be minimized by using reflective sidewalls and a lamp arrangement designed to promote uniform distribution (area sources such as fluorescent lamps). Consideration should be given to inclusion of side and base sources to optimize irradiance within the unit.

D. Barrier

Light barriers should have high transmission with consideration given to using filters for undesirable wavelengths, such as ultraviolet or infrared. The transmission of barriers should be characterized from 250 nm to 50 micrometers.

E. Photoperiod and Photocycle Regulation

Photoperiod should be variable to allow any day/night length. To study rapid light/dark variations as a means of reducing the overall power requirements of an eventual CELSS, the ability to strobe light sources would also be desirable.

II. Equipment must meet the plant growth parameters as well as the following.

A. Sources

1. The lamp canopy configuration should be optimized for use of either fluorescent, HID or other light sources. Consideration should be given to supplying light via a "lightpipe", lens combination, such as the Japanese "Himawari".
2. The lamp canopy should allow for temperature control to maximize efficiency of different light sources.
3. The volume required for installation and the energy required for control should be minimized.
4. The light canopy and the plant chamber should have separate environmental controls to isolate their energy requirements and to optimize both environments.
5. There should be modular light canopies so that various light sources can be used interchangeably.
6. Maximize photosynthetic efficacy of source.
7. The total system, sources as well as barriers and light piping/lens materials, should be selected to filter the radiation and thereby optimize plant growth

IRRADIATION (cont.)

and productivity.

B. Barrier

1. Barriers must be compatible with the air distribution system.
2. Barrier design should allow quantification of the aging effects of the transmitted radiation, and eventual replacement of the barrier if needed.

C. Measurement Systems

Spectroradiometric measurements should be possible from 250 to 2000 nm with a bandwidth \leq 10 nm. At greater than 2000 nm the radiant energy should be measured at the minimum bandwidth permitted by the available instrumentation.

AIR FLOW

Larry Anderson, Chair

1. The air flow path over the plants should be kept as short as possible.
2. The air flow path should be vertical, from bottom to top.
3. The air velocity should be variable from 0.2 to 0.9 m/s. The plenum should be designed to be adjustable with a slotted base or with holes so that air flow variation is minimized across the chamber.
4. The air flow must be great enough to remove the heat load within the chamber.
5. Provision must be made for external or internal scrubbing, and for adding, diluting, mixing and completely purging the gases.
6. The design should permit a minimum of 2 to 3 air exchanges per minute within the plant canopy.
7. Air flow sensing can be accomplished by the use of portable instruments, except for safety controls to detect fan failure.

In an attempt to determine the air flow requirements within a plant growth module, the committee asked itself some basic questions:

1. What does the moving air accomplish? Is the moving air anything more than a transport mechanism?
2. What must the moving air do to optimize plant production?
3. What is happening incidentally as the primary function is being achieved?
4. Are there detrimental effects of moving air?
5. Could some other physical phenomena be used to achieve the same desired results?

Discussion of the first question used all the available time. The committee acknowledged that while the moving air stream is acting as a transport system, it is a special one where some of its components are being consumed or augmented. It was suggested that the requirement to move heat was very critical, and perhaps the most demanding. [Considering this, perhaps question 5 should be given further consideration. Editors] One critical factor in a closed-loop control design such as the thermostatic control of a heated vessel is keeping the "transport lag" short. This means that the fluid (air) stream should be short, so that the controlled space is closely coupled to the controlling device (the

AIR FLOW (cont.)

heating and cooling elements). Similarly, to minimize temperature gradients the path from the inlet to the outlet (supply to exhaust) should be as short as possible. These criteria suggest a chamber design with air flow across one of the shorter dimensions with the fan/coil unit and ducts positioned to give the minimum length air path.

Since the chamber will be used to test hypotheses about the optimal conditions for plant growth, an effort must be made to subject all plants to identical growing conditions. This would suggest that if there is any temperature or humidity gradient inherent in the operation of the air conditioning system, that gradient should be along the axis of the plant stems, rather than from plant to plant. This consideration strongly favors a vertical air flow.

While the experience of a majority of the committee suggests an upward air flow through the plant canopy is better, there were counter arguments for downward flow. While it was suggested that upward flow would do a better job of permeating the canopy (because of the architecture of the leaf and the formation of a natural plenum by the canopy) there are benefits to using the cooler incoming air to scrub heat from the barrier to control long wave radiation. This need should be taken into account in the overall chamber design. [The evaluation of supply grills or ports designed to aspirate room air and provide some pre-mixing and reduce gradients will be useful. Editors]

To satisfy the requirements for air mixing, heat removal and control loop design, the air velocity should probably be as high as possible. However, excessive wind speed damages or disturbs the plants so that the optimum would be a velocity such that "the leaves just flutter slightly". While this may seem imprecise, it would indicate that the boundary layer of heat, moisture and "used" air is being scrubbed at the leaf surface, thereby providing the plant with the desired conditions.

AIR FLOW (cont.)

The total volume of air moving through the chamber per unit time, as distinct from the air velocity, must be such as to transport the heat and moisture being supplied or removed, and to refresh the supply of carbon dioxide and oxygen and to remove other gaseous materials released by the plant, or by components of the growth module itself. Practical experience suggests that 2 to 3 air exchanges per minute are required. Under some experimental conditions an exchange of chamber air for outside air might be required as well. If the system is to be run in a closed-cycle mode, provision must be made for internal or external scrubbing, adding, diluting, mixing and purging of the air and its components.

Except for safety controls to detect fan failures, the use of portable instruments to measure velocity will probably suffice. This would allow for measurements to be made at or near the active leaf regions as well as near grills.

PLANTING AND HARVESTING

Bruce Bugbee, Chair

I. Planting

A. Direct Seeding

1. Advantages

- a. Considerably less labor involved than transplanting
- b. More amenable to automation

2. Disadvantages

- a. Somewhat reduced uniformity
- b. Less efficient interception of radiation, unless variable spacing is used
- c. Increases the importance of careful seed selection prior to planting, though even seed selection could be mechanized

B. Transplanting

1. Advantages

- a. Plants can be selected for uniformity
- b. Doesn't require chamber space for germination in those experiments where that stage is not important to the investigation
- c. More efficient interception of radiation without variable spacing, because young plants can be started close together

2. Disadvantages

- a. Very labor intensive
- b. More potential for damage during the transplant operation, with a resultant increase in mortality or spurious results
- c. Would necessitate careful transplant selection, which would be difficult to automate

C.

PLANTING AND HARVESTING (cont.)

Automatic Seeding Devices

1. Most important with closely spaced plants such as wheat
2. Numerous commercial types are available
 - a. vacuum
 - b. pre-seeded cassette
 - c. seed tape
 - d. pneumatic

D. Automatic Transplanting Devices

Transplanting is labor intensive and is difficult to automate. Any available devices need to be investigated.

E. Planting Media

1. Must provide support and facilitate handling of young plants.
2. Should be recyclable if the ultimate concern is using the facility as part of a CELSS prototype.

II. Continuous vs. Batch Culture

- A. Both should be available.
- B. Environmental conditions for continuous culture may need to change in an operating CELSS, since young plants benefit from conditions that are different from those of mature plants.
- C. Continuous culture may be better for production objectives because plants can be sequentially harvested.
- D. Batch culture operation would be better for plant research because environmental conditions can be altered and plant response can be monitored at distinct stages of development.

III. Plant Spacing

- A. Fixed spacing has the advantage of much less complex design and construction.
- B. Variable Spacing

PLANTING AND HARVESTING (cont.)

1. Advantages

- a. Much more energy, mass and volume efficient
- b. Very important with directly seeded crops and for crops with vertical leaves

2. Disadvantages

- a. May prevent the use of certain types of nutrient delivery systems
- b. Roots may intermesh and prevent variable spacing unless some type of spacer is used to keep roots separate.

IV. Harvest

- A. Easily mechanized, though new designs would be needed for crops which would be continuously harvested
- B. Many automated devices are available
- C. Harvest system would also need to remove nonedible stems, roots and leaves

V. Additional Comments and Summary

- A. Variable spacing of plants beneath lamps is highly desirable. For wheat the anticipated range of variability would be from 2 mm by 2 mm at seeding, up to 50 mm by 50 mm at maturity. Calculations indicate that variable spacing could increase yield per unit area by up to 60% without increasing energy input.
- B. A gantry, bridge crane, or remote manipulator arm(s) could be very useful for plant manipulations.
- C. Flexibility of use for different crops and different cultural systems is critical.

CARBON DIOXIDE

Steve Schwartzkopf, Chair

Carbon dioxide is an extremely important factor in plant growth studies. Because of the different metabolic roles played by atmospheric CO₂ around plant leaves and roots, a primary recommendation made by the group was that the top and root zones be isolated from one another by a CO₂-impermeable barrier. Such a barrier will require that separate mechanical systems be developed for the two zones, but it will enable the collection of much needed information on carbon partitioning and mass balance. For discussion and design purposes, the group divided the topic of CO₂ into two functional tasks: monitoring and control.

For atmospheric CO₂, it was suggested that the monitoring system be designed to include an intake manifold, pump, flow regulator, gas drier, and particulate filter, and to use an infra-red gas analyzer (IRGA) as the monitoring device. It was also suggested that this design would make it possible to monitor CO₂ concentration throughout the entire chamber with only one IRGA. The IRGA itself, should be capable of achieving measurement precision to ± 10 ppm. The number of manifold inlets was not specified, however they should be large enough to insure that CO₂ concentrations within the chamber can be controlled to within ± 25 ppm or $\pm 5\%$ of the setpoint, whichever is greater. It was also suggested that provision be made in the manifold for use of two IRGA's, for those cases where an experimenter might want to control CO₂ at two widely disparate concentrations. (For example, a 350 ppm daytime concentration, and 10,000 ppm nighttime concentration. If two IRGA's are used, one could be calibrated for the range 0 - 1,000 ppm for daytime control, and the second could be calibrated for 9,500 - 10,500 ppm for nighttime control. Thus, both would have the same precision about their respective ranges.) It was also suggested that the IRGA monitoring system include automatic calibration, and that at least one spare IRGA be maintained for each unit in the system, as a replacement in case of malfunction.

It was suggested that the control system include provisions for both adding and subtracting CO₂. Addition would be most easily accomplished through the use of an injection manifold which introduced either a known volume or a known flow rate of pure CO₂ into the chamber. The number of points at which CO₂ should be added to the chamber was not specified, but the number should be sufficient to maintain the precision specified above. It was suggested that the CO₂ removal system utilize a regenerable adsorbent buffer, such as molecular sieves, if possible. In those cases where mass balance is not required by the experimenter, LiOH or a similar absorbent could be used.

Monitoring and control of CO₂ in the root zone is a more complicated task. Regardless of the specific culture technique used, either hydroponic or aeroponic, the concentration of CO₂ in both the gas and the liquid phase will be of interest. It will

CARBON DIOXIDE (cont.)

probably be possible to monitor and control CO₂ in the root atmosphere with the same system as used for the top atmosphere. CO₂ dissolved in the nutrient solution will be somewhat more difficult to deal with. Monitoring might be accomplished by ion-specific electrode, automated wet chemistry, or by some form of liquid chromatography. Control, however, will be difficult because of the necessity for simultaneously controlling both the pH and CO₂ concentration of the nutrient solution. No specific recommendations were made on how this would be most easily accomplished. It was presumed that the root atmosphere in the aeroponic system would likely be sufficiently mixed by the spray action of the aeroponic nozzles so that little or no additional atmosphere movement would be required to produce a homogeneous atmosphere. In a hydroponic system, however, it was felt that some form of air movement would have to be supplied to insure mixing of the root atmosphere. The precision of control and uniformity through the chamber was specified as the same values for the top atmosphere (± 25 ppm or $\pm 5\%$ of setpoint, whichever is greater).

The group felt that the range of control for CO₂ should include both values of interest from an experimental viewpoint as well as values that might arise in spacecraft cabins. The group defined this control range to be from 25 ppm CO₂ to 1% CO₂ (10,000 ppm). 1.5% CO₂ has been found in spacecraft atmospheres and it may be useful to allow for control up to 2%.

TEMPERATURE AND RELATIVE HUMIDITY

Craig McFarlane, Chair

I. Temperature

A. Air

Air temperature should be controllable between 5 - 40°C in dark and light. There should be the ability to vary control and set values over any period, i.e., provide for changing temperatures throughout a day or over the growth cycle of a plant. This should be available through advance programming. It should be noted that the range of control needed for research is much wider than the range acceptable in a spacecraft system.

B. Root Environment

Should be controllable between 5 - 40°C. If an aeroponics system is used, 2 solution tanks maintained at different temperatures should be used to provide light and dark nutrient solution temperature cycling coincident with conditions in the aerial environment.

C. Control

Should eliminate large variations which result from heater/chiller cycling. We recommend a fully proportional control system. Variation should be at most $\pm 0.3^\circ\text{C}$ at the control point. Spatial variation should be at most $\pm 1^\circ\text{C}$ within 90% of the plant growing volume, regardless of plant density or age.

D. Measurement

Bulk air temperature should be measured and continuously recorded. Provision should be made for temperature safety override alarm and shut down if needed. Provision should be made for both continuous and periodic air temperature monitoring, with ports, plug-in sensors or IR reflectance canopy and leaf monitoring.

II. Humidity

A. Control Limits

The control limits should be between 35% and 90% RH. Generally, humidity will be within the range of 50-80% RH for optimum plant growth. Requirements for lower humidity may exist when plants are maturing, for example when wheat is drying. This demand will generally be associated with conditions of low water insertion rates and thus represent a special condition. It is recommended that the condenser not be below 0°C because of the difficulty encountered

TEMPERATURE AND RELATIVE HUMIDITY (cont.)

with icing. Nevertheless, it is recognized that low humidities (at or below 35%) at low temperatures, especially in the dark, are impossible without a dew point below 0°C. This is a special condition of little importance. Thus, the limit of 35% RH applies only to lighted conditions and temperatures greater than 25°C. Low humidity may also be desirable for increasing potable water yield. That would not require below freezing dew points.

There is a need for lower humidity to examine the effect of high CO₂ on wheat and other crops. High CO₂ causes stomata closure, which reduces transpiration and thus movement of nutrients to the leaves. Decreased humidity could increase transpiration and possibly accommodate this need. In this condition water insertion rate would be low, temperature high (30 - 35°C) and thus dehumidification easier. Under these conditions, provide 20% RH in air.

B. Variability

Control should be within ±5%, or state of the art.

C. Humidification

Humidification will not generally be necessary because of the enclosed situation. However when plants are small, or when low temperatures are demanded, some low level of water insertion may be necessary. The source water must be pollutant free. It is suggested that ultrasonic atomization and steam injection be considered. The humidification system should not result in any droplet formation on the plants or the chamber.

D. Measurement

Measurements of the bulk air should be made and continuously recorded. We recommend that both IRGA and wet/dry bulb systems be evaluated.

OXYGEN

Robert MacElroy, Chair

1. C3 plant efficiency of vegetative growth can be increased if O_2 is decreased.
2. C4 plants are unaffected by O_2 concentration.
3. O_2 is needed for root growth; roots use O_2 to produce energy needed for transport.
4. O_2/CO_2 ratios are important and possibly also the O_2/CO_2 /Ethylene ratio.
5. Range for O_2 between 5% and 20% is OK.
6. There is no information on the effect of O_2 above 20%.
7. Physiological responses to O_2 are seen in the short term. Long term effects are not clear.
8. Decreased O_2 has inhibitory effects for roots and reproductive growth does not occur for some species (e.g., soybeans and wheat) at low O_2 concentrations.
9. Half normal concentrations of O_2 in the root zone are considered to be anaerobic.
10. There are effects of O_2 on microbial growth.
11. The demand for O_2 by roots is stimulated by heavy metal stress.
12. There are plant species differences in root O_2 responses.

CONSTRUCTION MATERIALS AND ACCESS

Robert Langhans, Chair

Construction Materials

It is vitally important that the materials used to construct the plant growth module not be phytotoxic. The two major sections of concern are the root and aerial zones.

Root zone: There is concern regarding the leaching of materials into the nutrient solution. Therefore, any construction material that is in contact with the nutrient solution or condensate from the cooling coils should be carefully screened for leaching of heavy metals like Zn, Cd, Ni, Cr, Cu, Co, Ag, Pb, and Al. Tubing used to transport the nutrient solution is also a source of phytotoxic material. Rubber and tygon tubing have been found to have toxic effects. Tubing made for moving food products, such as teflon and some polyethylenes (especially very high molecular weight, high density, polyethylene such as that manufactured by the Philips Petroleum Co. under the trade name Drisco) have been used successfully.

Aerial zone: Aerial parts of the chamber can be built of PVC, stainless steel, aluminum and glass. We suggest that care be taken in working with the following materials:

- . paint
- . sealants
- . gaskets
- . preservatives
- . glues
- . mastics
- . rubber

Any of the above materials should be screened to check for phytotoxicity. Materials that should not be used include:

- . galvanized steel
- . copper
- . brass

Testing

It is suggested that a biological test be used to test each of the materials used in the plant growth module.

Access

It became apparent in the discussions that access to the chamber will be a big problem. One of the objectives of the ground based plant growth module is to demonstrate that it can be kept gas-tight for a period as long as one year. Yet during this time a number of operations involving the plants and equipment will have to be performed. The following is a list of functions which might require working access to the plants.

CONSTRUCTION MATERIALS AND ACCESS (cont.)

1. Plant growth --- seeding, germination, transplanting, spacing, supporting, pollinating, etc.
2. Harvest --- removal of mature plants, fruits or seeds
3. Tissue and solution sampling
4. Observation of aerial parts of the plants
5. Measurement during growth of plant height, leaf width, fruit size, etc.
6. Manipulation of special equipment --- porometer light measure, leaf index, temperature probes, etc.

Three means are suggested to allow access for manipulating the plants.

1. Glove and access ports
2. A walk-in entrance, with a walkway and airlock if necessary
3. Robotics/Automation: Automated devices or robotics with video or optical monitoring. Although this area has been recognized to be important to PGM development it requires further definition.

There are pros and cons for each option. It may be that all will be necessary in designing the first breadboard unit.

The following parts would be required for maintenance or replacement of the mechanical equipment.

1. Cooling coils
2. Heating units
3. Humidity nozzles
4. Air handling equipment, such as fans, louvers, etc.

This equipment should be situated as close as possible to the chamber. It should be redundant and easily accessible for replacement (modular) without stopping plant growth or the operation of the module and (to the maximum possible extent) without breaking the gas-tight seal.

A priority list for system shutdown may be required to minimize the impact to experiments of power or other system failures.

CONSTRUCTION MATERIALS AND ACCESS (cont.)

Vibration

Vibration should be kept to a minimum. Excessive vibration can cause plant growth problems. The magnitude and frequency of vibrations should be no greater than that found in commercial plant growth chambers.

VOLATILE COMPOUNDS

Ted Tibbitts, Chair

Several different volatile compounds are known to be released in controlled growing systems. Some of these can be toxic to plants if concentrations are permitted to exceed certain limits. Other volatiles are not recognized to be toxic to plants but may be toxic if concentrations reach abnormally high levels. Of particular concern in this system are volatiles that are not presently recognized to be phytotoxic, but may be phytotoxic when the system is kept closed for long periods of time.

Principal emphasis in the report has been placed upon volatiles that will be released in the plant-growing subsystem. In an operable CELSS, information would also be needed about volatile compounds released from the other subsystems, such as waste processing, human habitation and algae growing areas.

Volatile compounds will originate both from living organisms and from hardware in the regenerative system. Compounds known to be released from plants and microflora in the plant growing sub-system include the following.

- Ethylene* (5 ppb)
- Carbon monoxide
- Terpenes
- Aldehydes
- Methane
- Other hydrocarbons
- Ammonia* (65 ppm)
- Amine oxides
- Cyanide
- Nitrogen oxides including NO, N₂O, NO₂,
- Sulphur compounds including H₂S, CH₃SH

* The starred compounds are of particular concern because they can cause injury to growing plants at the indicated concentrations.

Compounds which may be released from the hardware in the system or during system set-up and which would be phytotoxic are:

- Plasticizers that release methyl chloride, or other chlorine or fluorine compounds
- Freon
- Ozone
- Mercury
- Selenium
- Heavy metal particulates
- Cleaning solvents

VOLATILE COMPOUNDS (cont.)

No welding or soldering should be performed in the plant growth module during plant growth experimentation.

Research is needed to determine rates of release of volatile contaminants from plants, materials and machines under the range of environmental growing conditions within the regenerative system. There is also a need to determine the chemical, photochemical and biological transformations that may occur within the system.

It would be desirable to have the capability to monitor potentially phytotoxic gases on a continuous basis, or at least hourly. Compounds with no significant phytotoxicity would require monitoring only on a weekly basis. Monitoring will likely require several different analytical procedures including gas chromatography, mass spectroscopy, ion chromatography and specific ion analyzers.

One method of reducing high levels of contaminants is by use of a catalytic converter or similar air-cleaning device, as is done on submarines and on the space shuttle.

BACTERIA, STERILIZATION, AND FILTRATION

Mel Averner, Chair

I. Reasons for Wanting to Remove Microbial Populations

- A. To control plant pathogens
- B. To control human pathogens, such as enterics
- C. To control system pathogens, such as denitrifiers
- D. To examine the effects of microbial populations on plant growth parameters.

II. Reasons for not wanting to remove microbes

- A. Maintain selected microbial populations on plants and in the rhizosphere to minimize the invasion of pathogens.
- B. Sterile media increases the potential for invasion of pathogens.
- C. Plants will release organics which serve as a microbial substrate.
- D. To minimize the need for extensive sterilization procedures.
- E. Experiments need to be performed to define these symbiotic microbial communities.

III. General Rule

Once an infection begins, it is difficult to stop without interfering with plant growth. Therefore prevention by appropriate startup protocols and management is critical.

- A. Use construction materials which do not leach organics into the nutrient solutions.
- B. Plants will release organics into nutrient solutions.
- C. Perform appropriate clean-up between experiments.

IV. Techniques for Sterilization

A. Air

- 1. Filters -- will remove dust; will not kill microorganisms

BACTERIA, STERILIZATION AND FILTRATION (cont.)

- a. Electrostatic filters -- require maintenance
 - b. High-efficiency particulate air filters (HEPA) -- require maintenance
 2. Ultra-violet light -- will kill microorganisms
 3. Fumigation -- can kill microorganisms
 - a. Formaldehyde -- possible carcinogen, can be vented
 - b. Gluteraldehyde -- possible carcinogen, can be vented
 - c. Chlorine released from sodium hypochlorite -- can be vented
 - d. Ethylene oxide -- carcinogen, can be vented
 - e. Wet heat (steam)
- B. Liquid
1. Filters -- clog, require maintenance and replacement
 2. Bacteriostatic columns (Iodine, Ag) -- may leach and may have flow rate problems
 3. UV light -- can destroy chelator and acquire salt deposits
 4. Chlorozone -- may cause accumulation of ozone
 5. Antibiotics -- may affect plants and be taken up into food produced by plants
 6. Organic ion exchangers to remove substrates -- can leach organics
 7. Wet heat -- steam
 8. Alpha-radiation
- C. Surfaces
1. Hypochlorite -- standard, removable
 2. Organic iodine (wecodyne) -- may not be removable
 3. Iodine vapor -- may not be removable

BACTERIA, STERILIZATION AND FILTRATION (cont.)

4. Detergent/sulfuric acid mix -- removable
5. Wet heat
6. UV light -- shadowing
7. Quaternary amines (quats) -- may affect plants

D. Monitoring

1. Direct sampling methods
 - a. Air -- membrane filters
 - b. Liquids -- membrane filters, conductance?
 - c. Surfaces -- swabs
 - d. Counts from plant materials
2. Both species and numbers should be monitored, as should community physiological indicators.
3. Symptoms of plant stress should be monitored.
 - a. Ethylene, ethane, ABA
 - b. Plant temperature
 - c. Laser or spectrographic reflectance
 - d. Evidence of microbial activity
 - a. pH
 - b. Fourier transform IR for microbial "signature" molecules
 - c. Plant genetic markers

V. Miscellaneous Considerations

- A. Automation vs. human tending. The chamber should be designed with ease of microbial investigation in mind. If human entry is allowed, sterile suits may be required (will not be necessary if normal microbial populations are allowed).
- B. Disinfestation of propagules, seeds or tissues

NUTRIENT APPLICATION SYSTEMS

Cary Mitchell, Chair

Types of Culture

Since the PGM will be a research facility, the design should be sufficiently flexible to accommodate investigations employing any of the major types of soilless culture methods including the following.

- Batch (tank) hydroponics
- Aeroponics
- Solid matrix flush culture
- Nutrient film technique (NFT)
- Capillary mat bottom irrigation

No single nutrient application system was favored exclusively, since the choice may depend upon plant-species requirements. However, sentiment was expressed in favor of exploring nutrient systems not absolutely dependent upon gravity, since these might be more easily extrapolated from a ground based PGM to a space-deployed CELSS with a minimum of additional research and development.

Limitations

Several discussion groups favored separate compartments for shoot and root atmospheres in the ground-based PGM. One of the concerns that arose early and often in the Nutrient Applications group was the need for adequate aeration of nutrient solutions. Although the optimum oxygen concentration that must be maintained in solution is an R & D question for each combination of species and growing conditions, it should be as high as possible so as not to limit plant growth. For example, air-saturated H₂O contains about 9 ppm O₂ at 25°C. With root/shoot compartmentalized NFT, high flow rates of nutrient solution are anticipated in each culture trough to avoid O₂ and nutrient depletion along the trough, as well as a gradient of plant growth from inlet to outlet end of the trough. Use of air jets, manifolds, cascades, and turbulent circulation within nutrient reservoirs were suggested as ways to avoid such deficiencies.

Transverse rather than longitudinal flow of liquid through troughs within the proposed PGM was proposed to minimize the number of plants along a given NF trough, thereby minimizing the chances of O₂ and nutrient gradients. It was further suggested that as little as 3 ppm O₂ might be tolerated in a nutrient solution if solution flow rate across the roots is great enough. However, the O₂ concentration differential between the solution and root surface was stated as being more important to root growth than was flow rate per se. It was further suggested that turnover rate of nutrient solution be defined in terms of the amount of biomass being supported by a given volume of nutrient solution.

NUTRIENT APPLICATION SYSTEMS (cont.)

This is a research question.

Needs Within the Delivery System

A need for remote sensors for O_2 , specific ions (such as NO_3^- , K^+ , NH_4^+ , Ca^{2+} , Cl^- , etc.), pH, and conductivity will have to be accommodated at various appropriate places within any nutrient delivery system. Alternatively, automated sampling and analysis of inorganic substances by high performance liquid chromatography or atomic absorption spectrometry could also be developed. Once again, the goal would be to achieve reasonable uniformity within the particular system and the pertinent issue seems to be adequate mixing of flowing solutions along their pathway. Anecdotal observations suggest that mechanical disturbance of roots, such as by vigorous mixing or flow of nutrient solution, may be less disruptive to plant growth than mechanical disturbance of shoot parts.

Opportunities

Sentiment was expressed in favor of adopting the use of benevolent plant/microbial interactions to NFT or aeroponics in order to enhance delivery of nutrients to the roots of plants growing in solutions containing treated recycled sewage. Rhizobia to encourage legume roots to fix N_2 and Mycorrhizae to encourage uptake of phosphates and other nutrients from dilute, recycled waste solutions would be compatible with overall CELSS objectives.

Other Needs

Monitoring and control of individual nutrients will have to be tested in the PGM, with appropriate numbers and placement of remote probes in solution and sufficient analytical facilities and laboratory personnel to support maintenance of the nutrient delivery system. Once again, if partially treated, recycled wastes are incorporated into the nutrient solution, steps will have to be taken to avoid problems resulting from biodegradation of wastes, such as microorganism buildup and micronutrient accumulation to toxic levels.

Suggestions for Nutrient Delivery Systems

Unless some sort of growth block or solid substrate is used in conjunction with nutrient delivery systems, there might be a rhizosphere headspace above the nutrient solution. Concern was expressed regarding the air pruning, browning or desiccation of roots that often occurs above the liquid phase. Since it may be desirable to recover roots from the system without adhering substrate, a need to develop systems that overcome this problem

NUTRIENT APPLICATION SYSTEMS (cont.)

was expressed.

Concern also was expressed regarding the potential use of construction materials that potentially release toxic substances into nutrient solutions. Examples given included black polyethylene, which releases copper and zinc. Rigid PVC may adsorb organic contaminants with the danger that they might be released at a later time into nutrient solutions or onto root surfaces. Materials containing plasticizers such as phthalates that can support microbial growth should be avoided or treated. Teflon-coated surfaces or ultra-high molecular weight and high density linear polyethylene were identified as construction materials that might be used because they are particularly inert and non-reactive. Use of Porylene, an inert coating material, also was recommended.

The need to recover and recycle growth substrate, such as capillary matting material, following a production cycle also was stated. A substance which is inert, porous and resistant to the combustion or chemical treatments used to remove roots is needed.

Finally, development of a nutrient delivery system compatible with microgravity and with 1 g conditions was identified as a key issue. One hypothetical system proposed involved pumping nutrient solution from one collapsible bag to another, alternately filling and draining roots of plants contained in one of the bags. Aeration would occur during the drain cycle. Details of this system were not worked out, but it was stated that it would be analogous to the pumping of an artificial heart. This example is by no means the best or only system that could be developed for the PGM.

NUTRIENT MONITORING

Wade Berry, Chair

In order to evaluate reasonable sample sizes for nutrient monitoring some assumptions must be made about nutrient volume per chamber. For the first approximation we have assumed that each NASA plant growth chamber nutrient delivery system will be subdivided into four compartments; one or two to be used for control or reference groups and the others for treatment groups. We have assumed that each compartment in the hydroponic mode will contain between 400 and 4000 liters of nutrient solution. The upper limit represents a scale-up of the Salisbury-Bugbee growth chamber for wheat at Utah State University, while the lower limit reflects a concern that the volume of the nutrient solution be sufficient to resist a sudden change in composition, and to permit adequate sampling.

The minimum capability for the frequency of nutrient solution sampling should be 4 samples per day for an entire growth period of about 120 days. The sample size should be 10 ml per sample to provide solution for both routine analysis and archiving. The total volume of the monitoring sample over the entire crop period would therefore be $(0.010 \times 4 \times 120)/400 = 1.2\%$ of the suggested 400 L minimum capacity of each nutrient delivery system.

The preferred method of analysis for mineral nutrients would be inductively coupled plasma-emission spectroscopy (ICPES) analysis for the cationic and trace elements. For the anionic elements the preferred method of analysis would be HPLC ion chromatography. Each of these analysis methods would require less than 1 ml of sample. Approximately 8 ml of sample would remain to archive for future analysis. For example, archived samples would provide a means to evaluate contamination that had resulted in delayed toxicity.

Tissue samples for mineral analysis should be taken at least once a week to verify mineral nutrient availability to the plants. The tissue sample should be at least 100 mg of recently matured leaf tissues and young root tips. (Such tissue may not be available during the first few weeks of growth.) The tissue samples will need to be prepared and put into solution before analysis. The tissue samples should be analyzed for the same elements as the nutrient solution and by the same methods. Any extra tissue should be archived for later re-evaluation if that becomes necessary.

The nutrient analyses should be as nearly real-time as possible. It would be highly desirable if the analysis of the solution were automated and on-line, thereby providing for real-time control of the nutrient solution. This, however, would not alleviate the need for routine sampling and archiving of solution samples for future reference.

NUTRIENT MONITORING (cont.)

At least the following elements would need to be monitored.

1. Essential macronutrients
N, P, S, K, Na, Ca, Mg, Cl, Fe
2. Essential micronutrients
B, Mn, Zn, Cu, Mo, Si
3. Potentially toxic elements
Cr, Ni, Co, Ag, V, Pb, Cd, Se, Fl, Br

NUTRIENT pH AND CONDUCTIVITY

David Raper, Chair

Rationale

The discussion group viewed this topic as an exercise in both monitoring and control. The technology for monitoring is available in the form of pH electrodes and conductivity meters. Both these devices can operate in real time and continuously, but a question was raised as to whether the simultaneous use of pH electrodes and conductivity meters might result in mutual interference. Although both devices are available, their reliability and durability could potentially be improved. Control of conductivity can be achieved through microprocessor activation of injectors for replacement of nutrient ions in response to signals from a conductivity meter. Control of pH can be achieved through a selection of options in response to signals from pH electrodes. Monitoring and control of pH and conductivity should be easily accomplished in liquid culture systems. Monitoring and control would be more difficult to accomplish in solid media, especially in the rhizosphere.

Conductivity Control

Conductivity monitoring and control must be considered because it involves controlling concentrations of nutrient ions in solution. The real-time, continuous nature of conductivity measurements would complement nutrient monitoring and control which will probably be done at discrete intervals by adding specific ions to re-adjust concentrations to desired levels. Conductivity monitoring and control offers an interim system for avoiding nutrient depletion in excess of the desired range of control. The range and precision of conductivity control that will be necessary must depend on the nutrient application and monitoring systems. Furthermore, nutrient requirements can be expected to vary with the age and species of plant being grown. Finally, it should be recognized that organic acids entering the nutrient system from plant roots will alter the conductivity of solution. This means that conductivity measurements must be calibrated against the total of all the ions in solution measured by nutrient monitoring. For this reason, monitoring organic carbon in the nutrient solution may be a valuable supplement to conductivity measurements.

pH Control

Control of pH should be available over the biological range of 4.0 to 8.0. It is expected, however, that most control will be to a fixed point within the range of 5.5 to 6.5 with a precision of control to within 0.1 pH unit. There are several options available for pH control.

NUTRIENT pH AND CONDUCTIVITY (cont.)

1. Additions of acid, such as H_2SO_4 , or a weak base, such as $Ca(OH)_2$ to control pH to a chosen range.
2. Additions of phosphate salts can be used to buffer the pH.
3. Additions of nitrate and ammonium can be used to adjust pH by the uptake and subsequent release of counter ions by plant roots.
4. Exchange resins and other means can be used to remove specific ions or all of them, followed by reconstitution of the nutrient solution. (Exchange resins can also be considered as an option for a buffered solid medium.)
5. [Editors note: Electrochemical pH control is also a viable option.]

All these options have an impact on the nutrient supply and control systems and thus must be selected with consideration of this interface. It seems advisable to implement several or all of these options so that selection of a specific option at any time can be made in reference to maintenance of nutrient control. It should be noted that pH control eliminates utilization of pH monitoring as a diagnostic tool for stress or failure of the plant system; however, the frequency of correction through the controller microprocessor can serve as an indicator of problems in the plant system.

N88 - 13855

-- SECTION III: --

PLANT GROWTH MODULE (PGM)

- CONCEPTUAL DESIGN -

Steven H. Schwartzkopf and Daryl Rasmussen

April 1985

INTRODUCTION

To support the CELSS research program, construction of a laboratory-sized (2-3 m²) plant growth module (PGM) at the NASA-Ames Research Center has been proposed. This PGM will be fully closed, and capable of maintaining the strictly controlled environmental conditions necessary to answer basic science questions related to growing plants in closed systems.

This section contains a conceptual view of the PGM design. The design requirements were gleaned from the recommendations made at the PGM Workshop reported in Section II, and the subsystem descriptions were formulated to fulfill those requirements. The subsystem descriptions will serve as a starting point from which the PGM design will be refined and developed. What follows, then, is the framework upon which the design and construction of the Ames Plant Growth Module will be based.

REQUIREMENTS

The PGM Workshop held at NASA-Ames in September, 1984 began the design definition phase for the development of the Ames PGM. Each of the topics discussed at that meeting was viewed individually, without a concentrated effort at system integration. As a result, some of the requirements for the PGM were contradictory, while there were no specific requirements decided for some of the topics. With that in mind, the design requirements as they are presently understood are listed in the following tables: Table 1 for the shoot zone, and Table 2 for the root zone of the PGM.

REQUIREMENTS (cont.)

Table 1

Nominal and control ranges for shoot zone environmental variables

Variable	Nominal Min	Range Max	Control Min	Range Max	Units	Comments
Carbon Dioxide	350	1500	25	10 ⁴	ppm	
Oxygen	5	21	5	40	%	No information is available on [O ₂] > 21%
Temperature	15	30	5	40	°C	
Relative Humidity	50	80	35	90	%	
Irradiance	400	700	0	1000	uM/m ² /sec	Measured at top of plant canopy
Air Flow	0.4	0.5	0.2	0.9	m/sec	
Volatiles		TBD		TBD	ppm, ppb	
Bacteria		TBD		TBD	cells/m ³	
Pressure		TBD		TBD	mm Hg	

REQUIREMENTS (cont.)

Table 2

Nominal and control ranges for root zone environmental variables

Variable	Nominal Min	Range Max	Control Min	Range Max	Units	Comments
Carbon Dioxide		TBD	TBD	10 ⁴	ppm	
Oxygen		TBD		TBD	%	Little data is available, but zone must be aerobic.
Temperature	15	30	5	40	°C	
pH	4.0	7.0		TBD	pH	
Conductivity	0.7	0.9	0.6	1.8	mS	
Volatiles		TBD		TBD	ppm, ppb	
Bacteria	100	10 ⁴		TBD	cells/ml	Estimates from studies at Ames
Pressure		TBD		TBD	mm Hg	

DESIGN

PGM FUNCTIONAL DESCRIPTION

The Plant Growth Module (PGM) will be a tightly sealed, low leakage device with a computer control system which will closely monitor and regulate the PGM's internal environment. In essence, the PGM will serve as a life support system for higher plants, such as wheat, soybeans, and potatoes. Since the chief purpose of the Ames PGM will be to conduct scientific research on a variety of crops, the design will incorporate a maximum degree of flexibility in the number of growing configurations available. Additionally, the design will emphasize accurate control over the PGM environment and will provide, to the maximum possible extent, fully-automated data monitoring and recording.

ARTIST'S CONCEPT DRAWINGS

Most of the design details for the Ames PGM have not been finalized, but several different designs have been envisioned for the plant enclosure itself. These alternatives are illustrated in Figs. 1 to 3. Common to each of these designs is the concept of modular support systems; as illustrated in the figures, each of the plant enclosures are connected to the same array of supporting equipment. These support systems are the subsystems of the PGM that will take the majority of the engineering effort involved in the construction of the PGM.

DESIGN (cont.)

Figure 1

Ames Plant Growth Module A

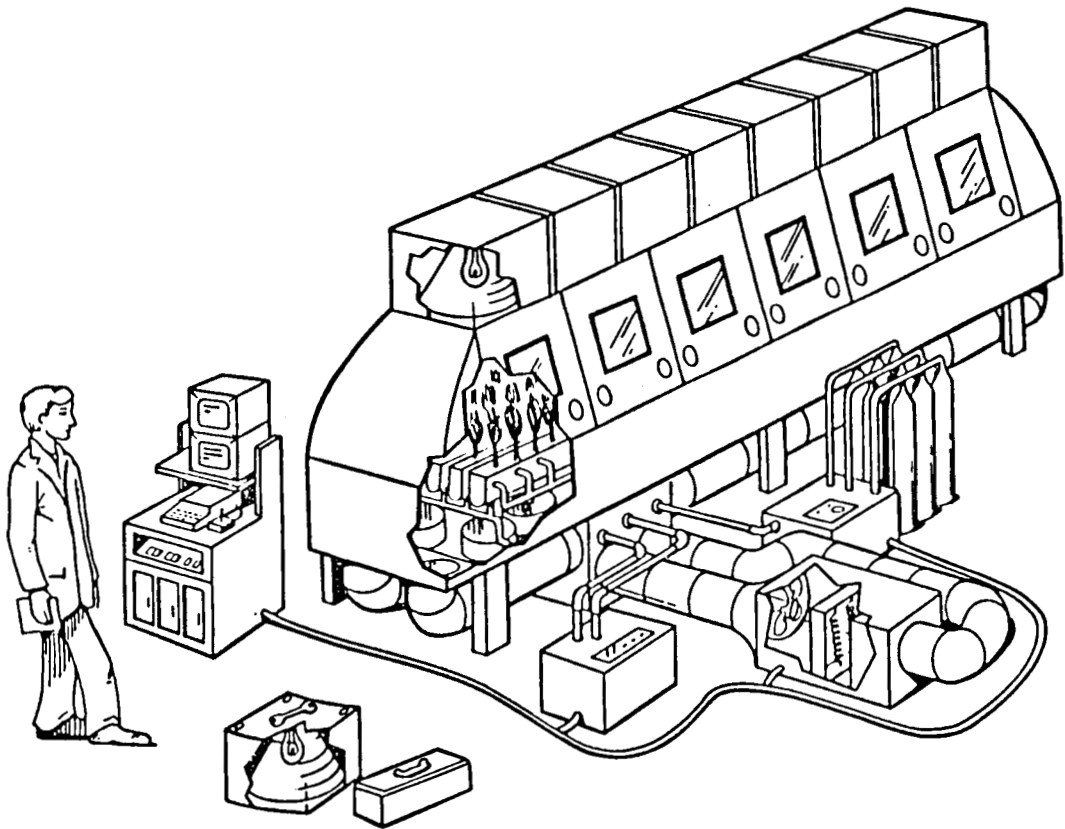

DESIGN (cont.)

Figure 2
Ames Plant Growth Module B

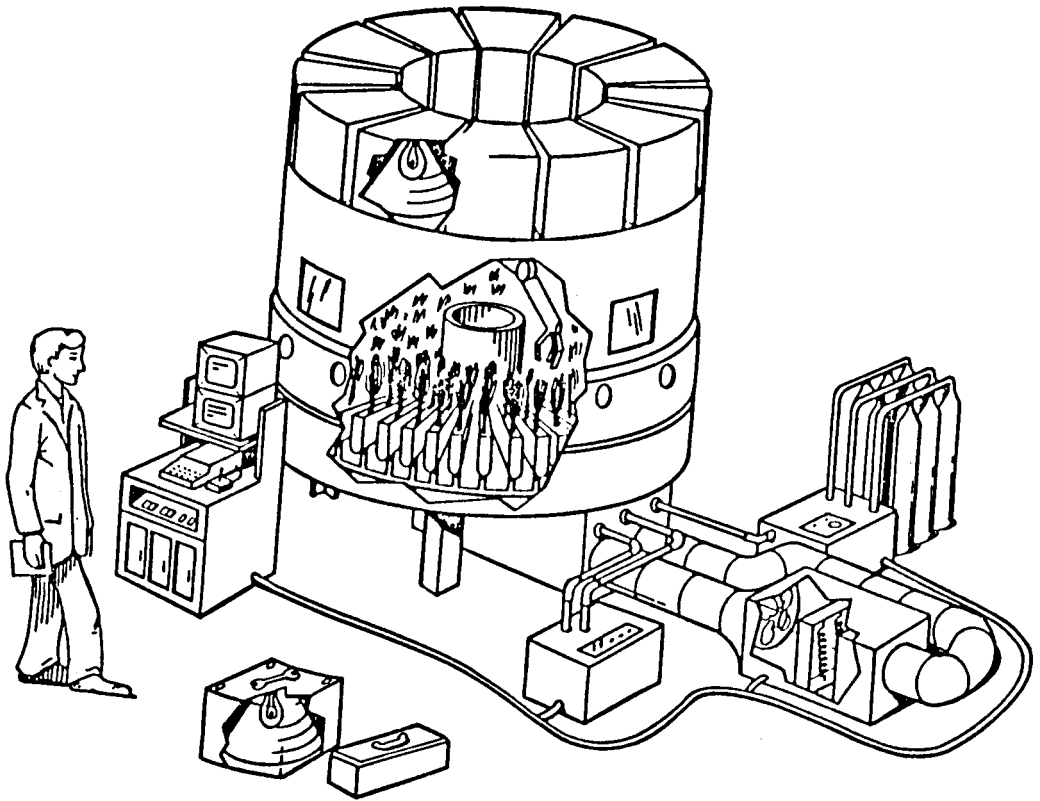

DESIGN (cont.)

Figure 3

Ames Plant Growth Module C

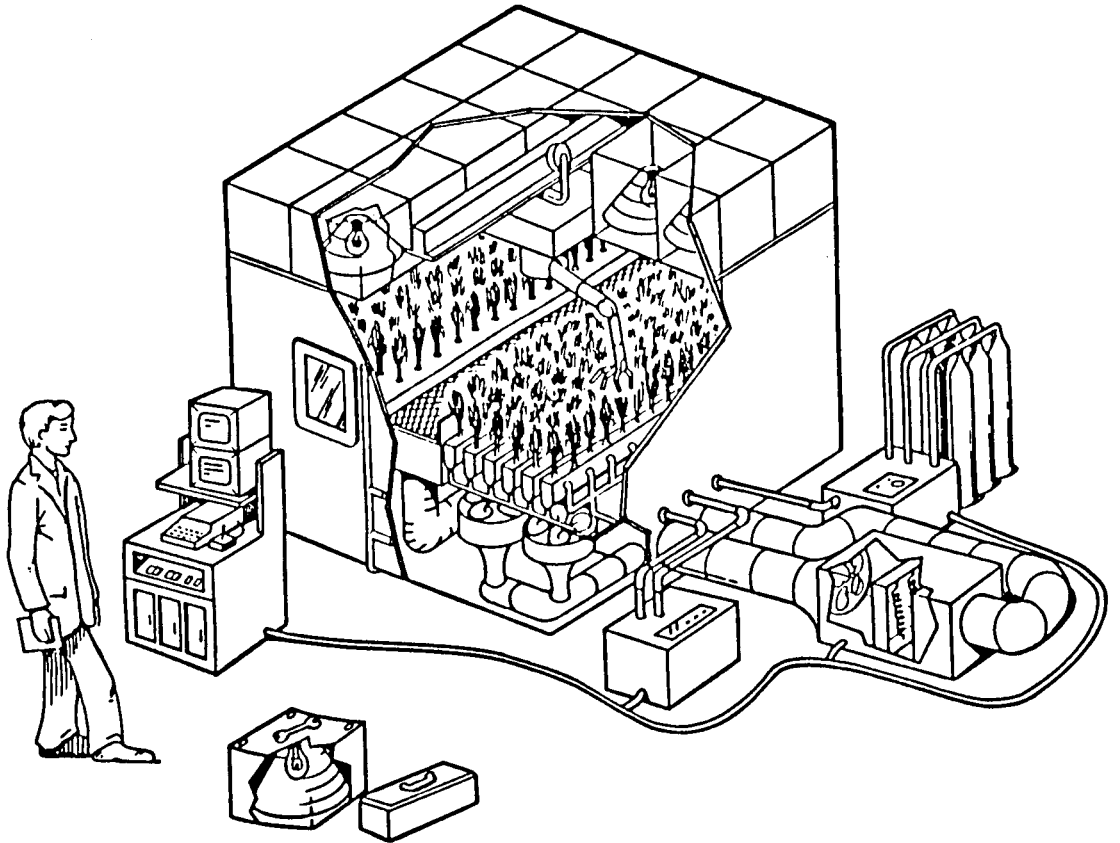

DESIGN (cont.)

PGM SUBSYSTEMS

As a result of joint scientific/engineering group meetings, the PGM design has been divided into ten subsystems (Fig. 4). This section provides a functional description of each of the PGM subsystems, along with a preliminary equipment list and a descriptive schematic.

1. Enclosure and Access

The functions of this subsystem are 1) to maintain an atmosphere that is isolated from the external atmosphere, 2) to maintain an atmosphere that is closed with respect to the exchange of materials, and 3) to provide a container within which the control system can maintain specific environmental conditions that are independent of outside environmental variables. Fig. 5 is a schematic diagram of this subsystem.

Typical Enclosure and Access Equipment

- Shell
- Illumination port
- Observation port
- Glove ports
- Electrical and plumbing interface ports
- Robotics mounting pad
- Airlock
- Airlock door

Figure 4

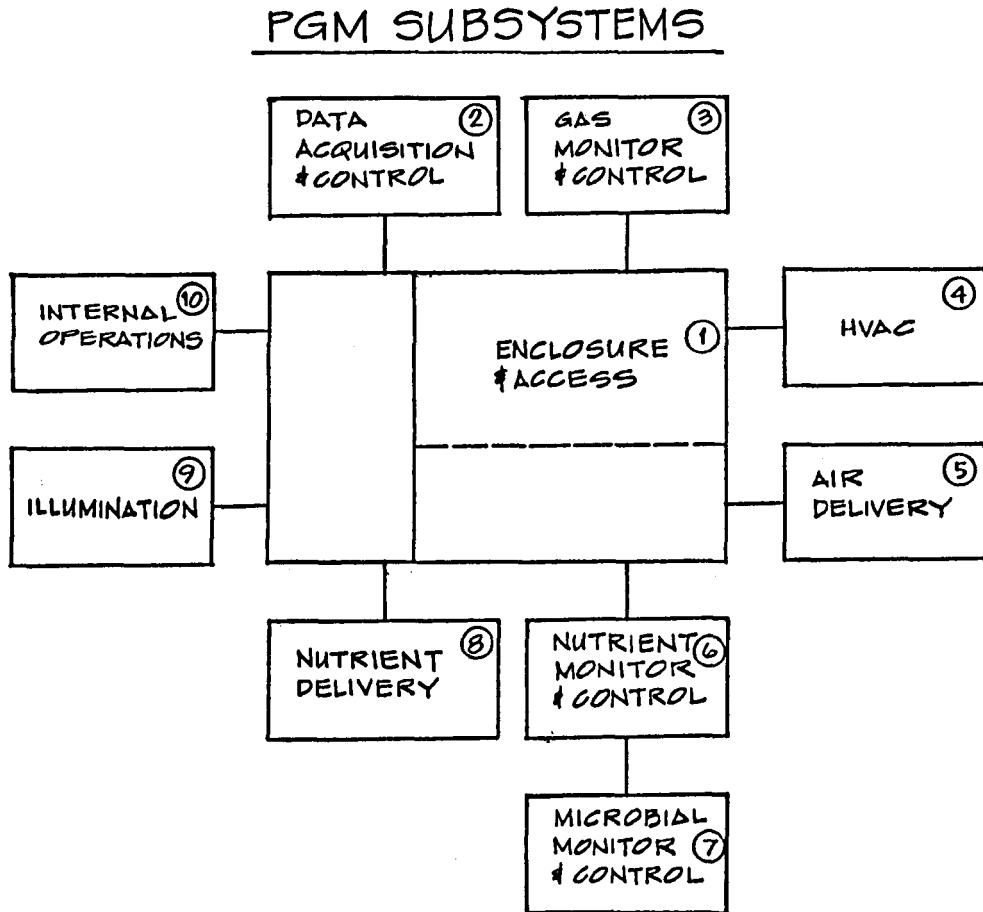
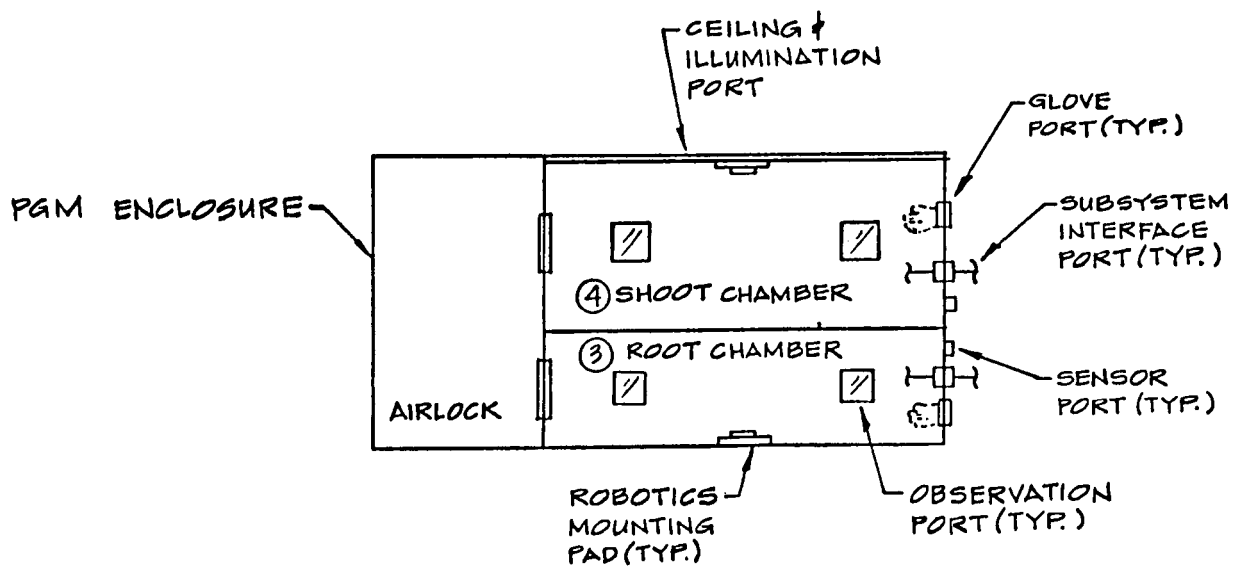

Figure 5

① ENCLOSURE & ACCESS



DESIGN (cont.)

2. Data Acquisition and Control

The functions of this subsystem are 1) to monitor the PGM environment and maintain that environment according to a specified set of control instructions, and 2) to record, analyze and report data for use in experimental analysis. Fig. 6 gives a schematic for this subsystem.

Typical Data Acquisition, Analysis and Control Equipment

- PGM Control computer
- CRT
- Operator's console
- Printer
- X-Y Plotter
- Hard Disc system
- Floppy Disc system
- Auto-dial modem
- Uninterruptible power supply
- Chart recorders
- Optically-isolated relays

DESIGN (cont.)

Figure 6

② DATA ACQUISITION, ANALYSIS & CONTROL

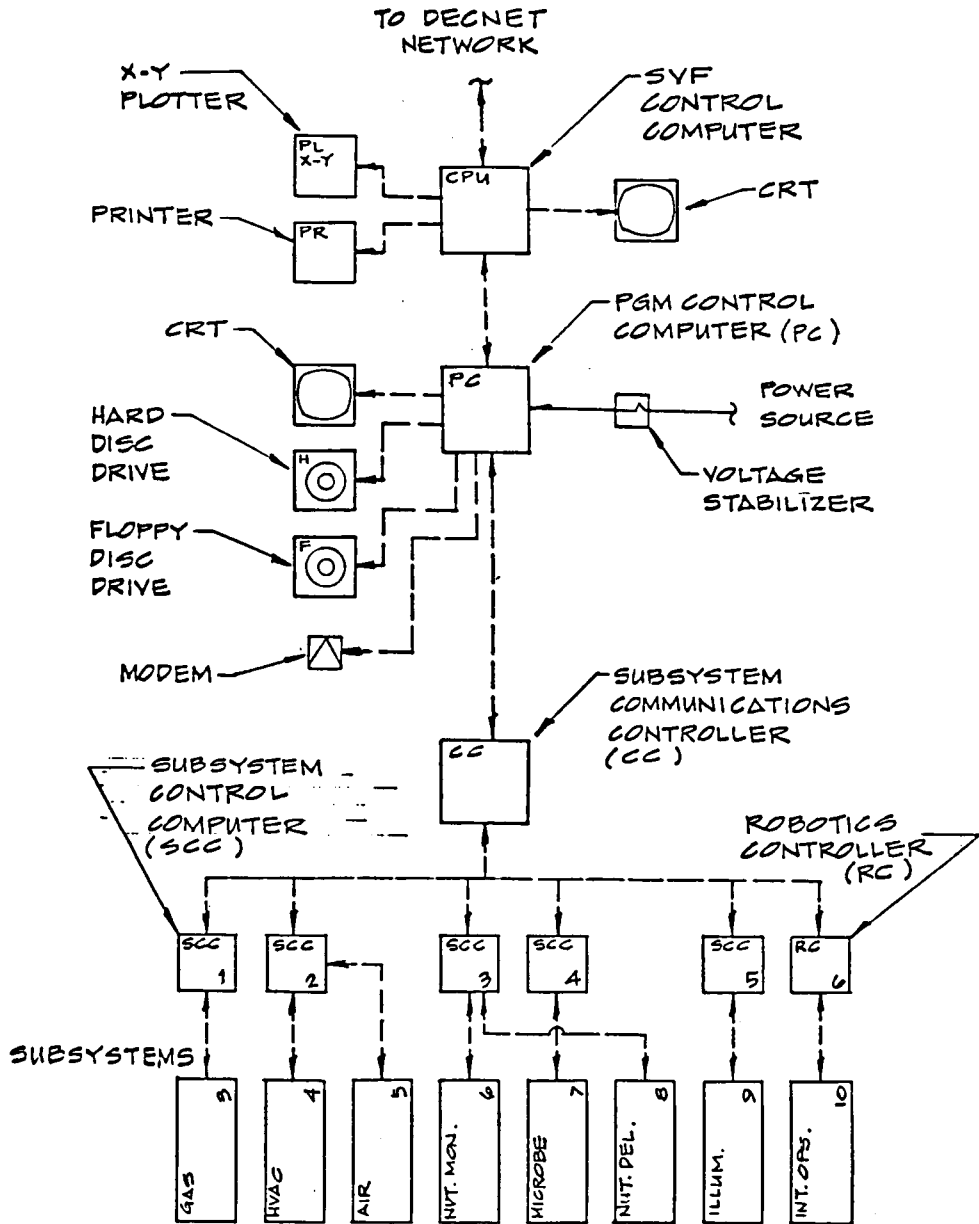

DESIGN (cont.)

3. Gas Monitor and Control

The functions of this subsystem are 1) to monitor atmospheric gas concentrations and maintain a specified gas balance, 2) to monitor and calculate carbon uptake and oxygen production due to photosynthesis, and carbon dioxide production and oxygen uptake due to respiration, 3) to monitor and replenish atmospheric gas buffers and 4) to remove any volatile components from the atmosphere. Fig. 7 presents a schematic for this subsystem.

Typical Gas Monitor and Control Equipment

- CO₂ Analyzer
- O₂ Analyzer
- Gas Chromatograph
- Solenoid valves
- Mixing valves
- Injecting valves
- Gas line filters (0.2 micron sintered metal)
- Gas line cold traps
- Pressure gauges
- Multichannel IR Analyzer
- Gas cylinders
- Pumps
- Compressors
- Flow monitor/control valves

Figure 7

③ GAS MONITOR & CONTROL

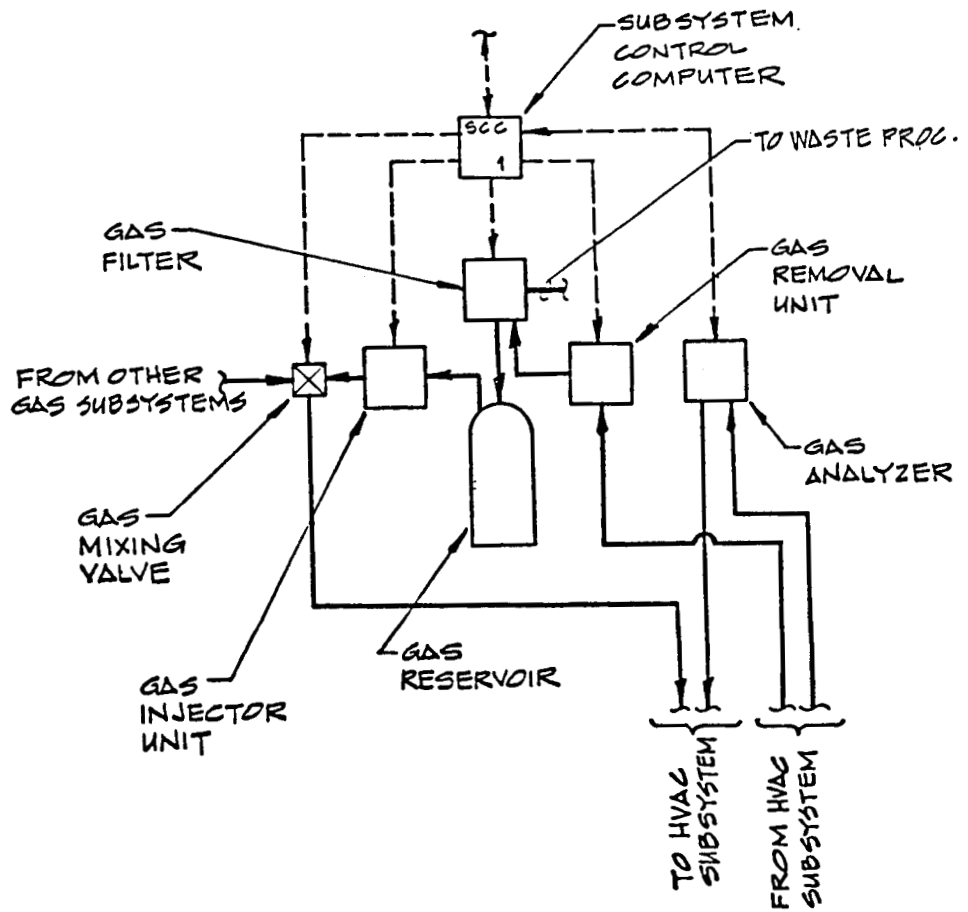

DESIGN (cont.)

4. Heating, Ventilation, Air Conditioning (HVAC)

The functions of this system are 1) to monitor and control atmospheric temperature and humidity, and 2) to monitor and calculate transpirational water loss from the plant canopy. Fig. 8 gives the schematic for this subsystem.

Typical HVAC Equipment

- Air conditioner
- Heater
- Filters
- Humidifiers
- Dehumidifiers
- Pressure sensors
- Flow sensors
- Temperature sensors
- Relative humidity sensors
- Fans
- Dampers
- Turning vanes

DESIGN (cont.)

Figure 8

④ HYAC

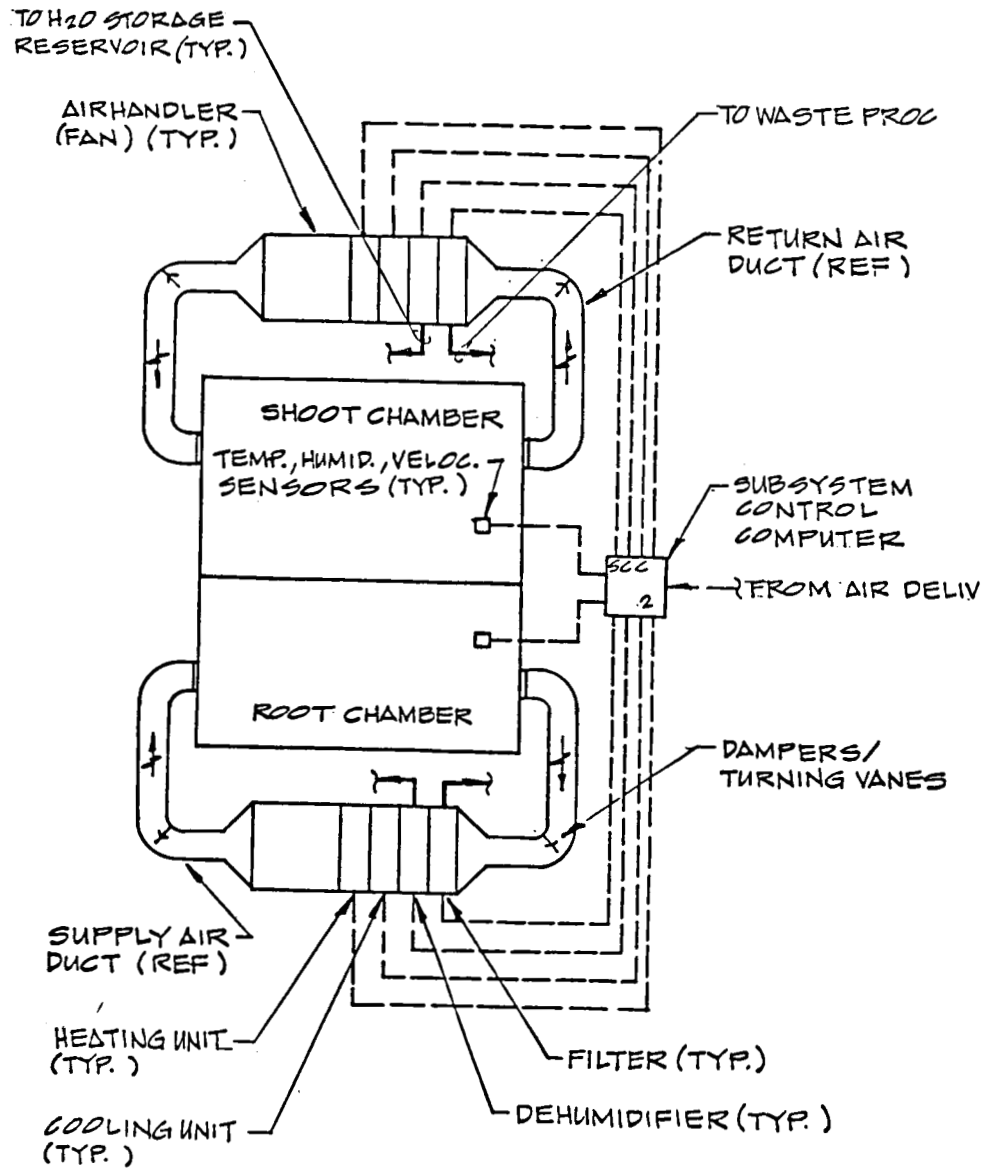

DESIGN (cont.)

5. Air Delivery

The function of this system is to provide uniform, homogeneous atmospheres for both the aerial and root zones of the PGM. Fig. 9 illustrates the design schematic for this subsystem.

Typical Air Delivery Equipment

- Return air plenum (top and root zones)
- Supply air plenum (top and root zones)
- Flow sensors
- Registers
- Dampers
- Turning vanes

Figure 9

⑤ AIR DELIVERY

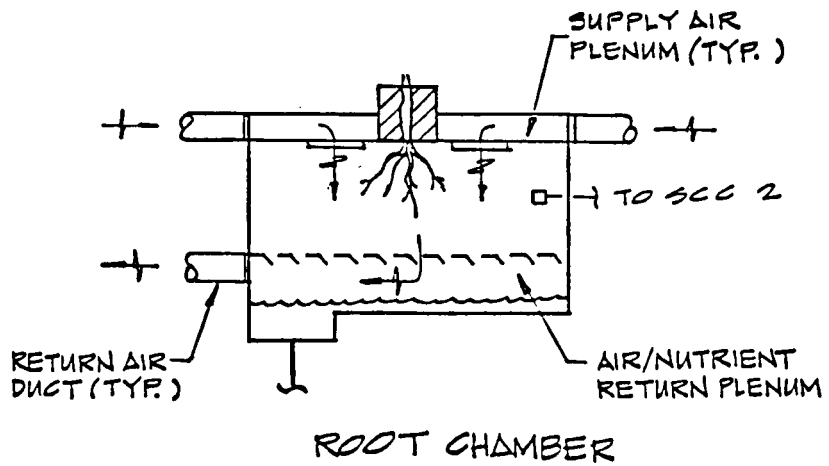
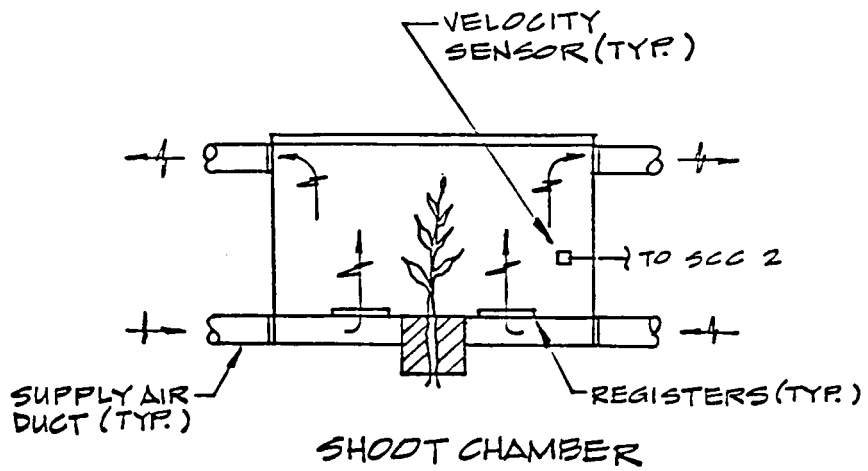

DESIGN (cont.)

6. Nutrient Monitor and Control

The functions of this subsystem are 1) to monitor and control the concentrations of individual nutrient elements in solution, 2) to monitor and control bulk nutrient solution parameters such as pH, conductivity and dissolved oxygen, and 3) to monitor and control nutrient solution temperature, and 4) to calculate and report nutrient uptake reports. Fig. 10 gives a schematic for this subsystem.

Typical Nutrient Monitor and Control Equipment

- pH sensors
- Conductivity sensors
- Dissolved Oxygen sensors
- Temperature sensors
- Liquid level sensors
- Filters
- HPLC
 - High pressure pump
 - Automatic injector valve
 - Ion-specific columns
 - Detectors (UV and conductivity)
- Heater
- Cooler
- Mixing pump
- Aerator
- Nutrient solution component reservoirs
- Metering pumps
- Nutrient solution reservoir

Figure 10

⑥ NUTRIENT MONITOR & CONTROL

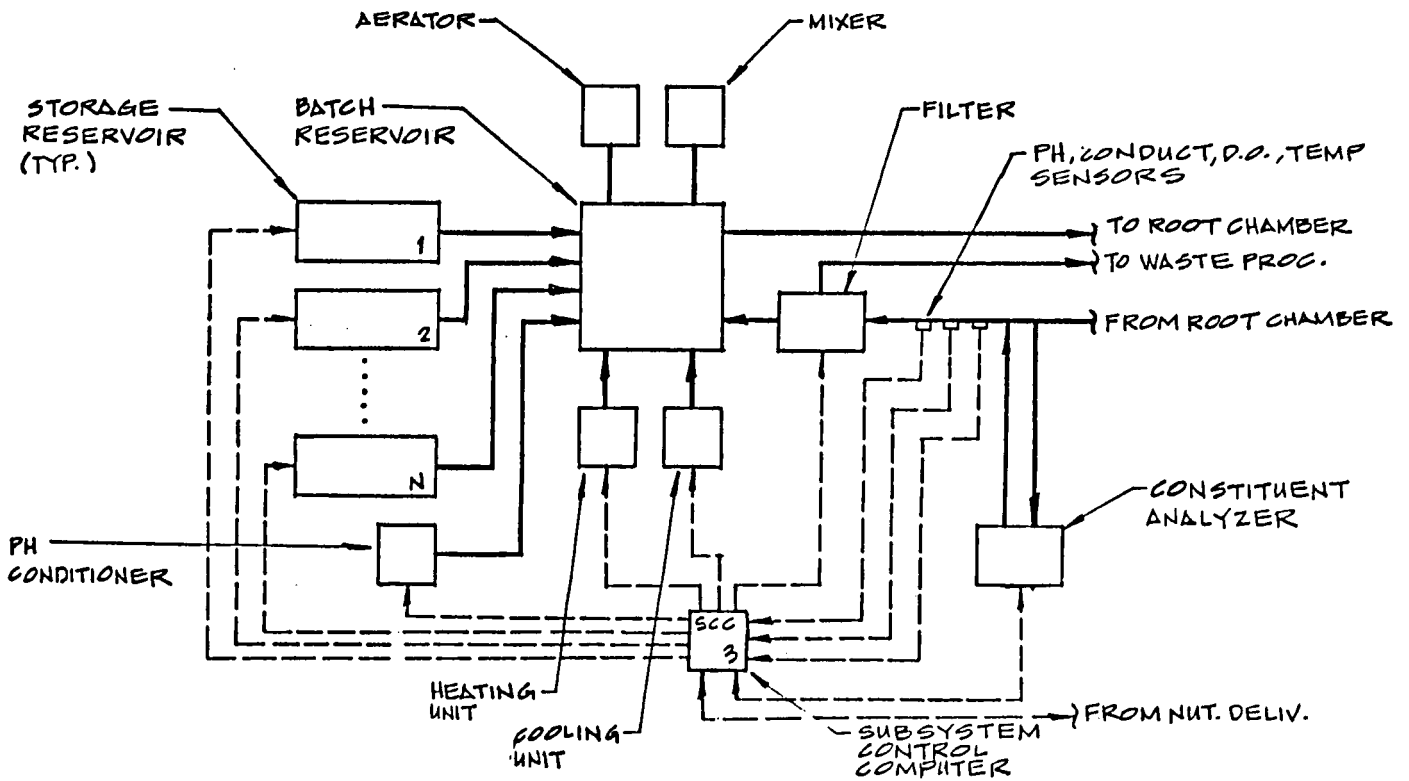

DESIGN (cont.)

7. Microbial Monitoring and Control

The functions of this system are 1) to monitor and control microbial concentrations in both the nutrient solution and atmospheric phase, and 2) to report monitored microbial densities. Fig. 11 illustrates the schematic for this subsystem.

Typical Microbial Monitoring and Control Equipment

- FTIR Spectrophotometer
- UV Sterilizers
- Flow monitor/control valves
- Pumps
- Externally-accessible sample port

DESIGN (cont.)

Figure 11

⑦ MICROBIAL MONITOR & CONTROL

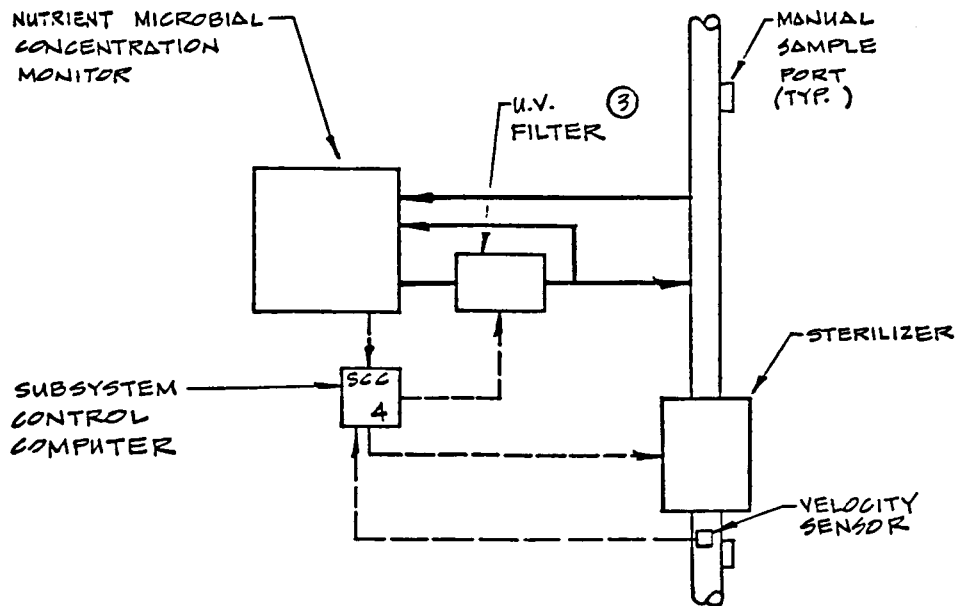

DESIGN (cont.)

8. Plant Support and Nutrient Delivery

The functions of this subsystem are 1) to provide structural support for the plants' roots and stems, 2) to distribute a homogeneous nutrient solution to the plants in a uniform fashion, and 3) to remove contaminants from the nutrient solution. Fig. 12 presents a schematic of this subsystem.

Typical Nutrient Delivery Equipment

- Pumps
- Mist nozzles or injectors
- Nutrient recovery sump
- Flow monitor/control valve
- Liquid level sensors
- Air/liquid separator plenum

Figure 12

⑧ NUTRIENT DELIVERY

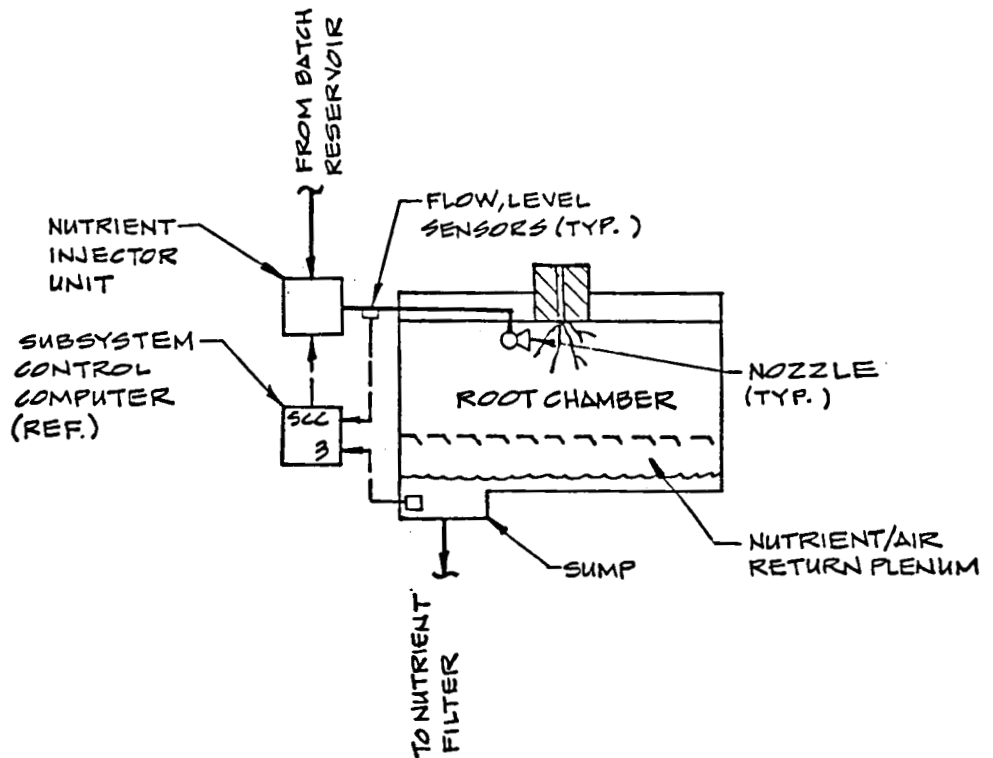

DESIGN (cont.)

9. Illumination

The function of this subsystem is to provide radiant energy of specific, controllable intensity and spectral quality to support photosynthesis. Fig. 13 illustrates a schematic for this subsystem.

Typical Illumination Equipment

- Lamps (HID, Metal Halide, Fluorescent)
- Light (PAR) sensors
- Spectral radiometer
- Controllable lamp ballasts
- Optical and IR filters
- Housing / Barrier

DESIGN (cont.)

Figure 13

⑨ ILLUMINATION

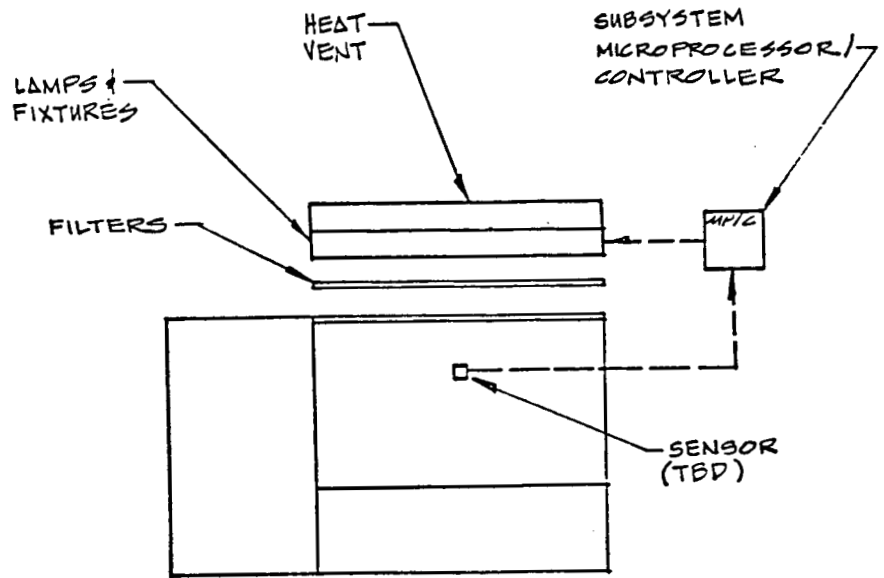

DESIGN (cont.)

10. Internal Operations

The functions of this subsystem are 1) to perform internal maintenance when the PGM is functioning, 2) to provide a means for planting, moving, and harvesting plants within the PGM, and 3) to provide a mobile sampling/sensing capability within the PGM that could be used to obtain additional environmental and biological data. Fig. 14 gives a schematic for this subsystem.

Typical Internal Operations Equipment

- Robotics
- Tool crib/tool set
- Optical port cleaners
- Seeder
- Harvester
- Mobile sensor platform

DESIGN (cont.)

Figure 14

⑩ INTERNAL OPERATIONS

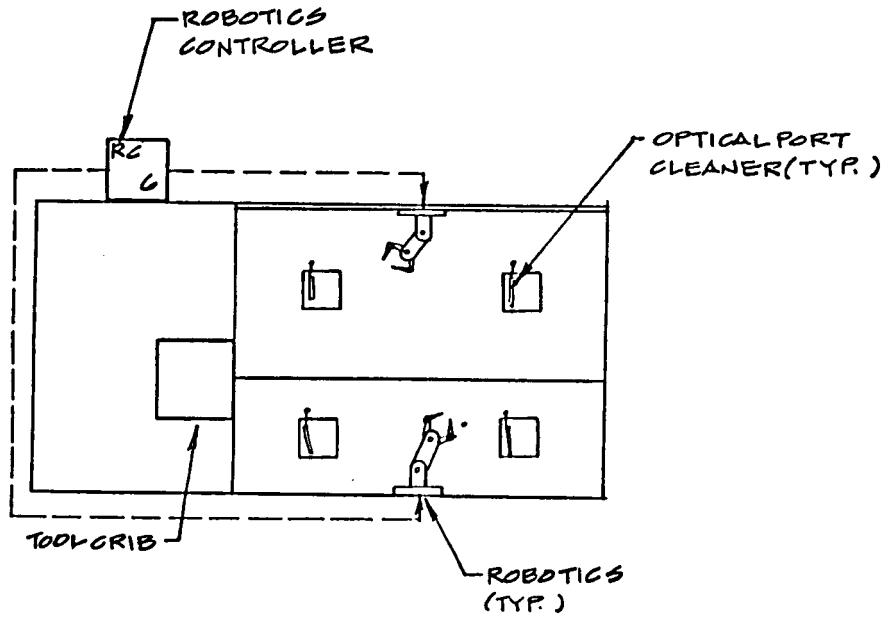

ORIGINAL PAGE IS
OF POOR QUALITY

HARDWARE DEVELOPMENT PLAN

DEVELOPMENT AND REVIEW PROCESS

In order to provide for an orderly translation of the scientific requirements for the PGM into a well-engineered reality, some canonical procedure is needed that will allow for an interchange between the eventual users of the PGM and the design team involved in its construction. As such, this is not a new problem, and the development plan outlined in Fig. 15 illustrates one such procedure that has been used at NASA to develop flight projects. Because the construction of the Ames PGM is not tied to the schedule of any launch vehicle, the development plan need not be quite so formal, so the dates shown in Fig. 15 may change as the design effort progresses. What should be emphasized is that the design reviews give project management an opportunity to evaluate the different design options in the early stages of the process, and with enough feedback to ensure that those options are implemented when PGM construction is begun.

Figure 15

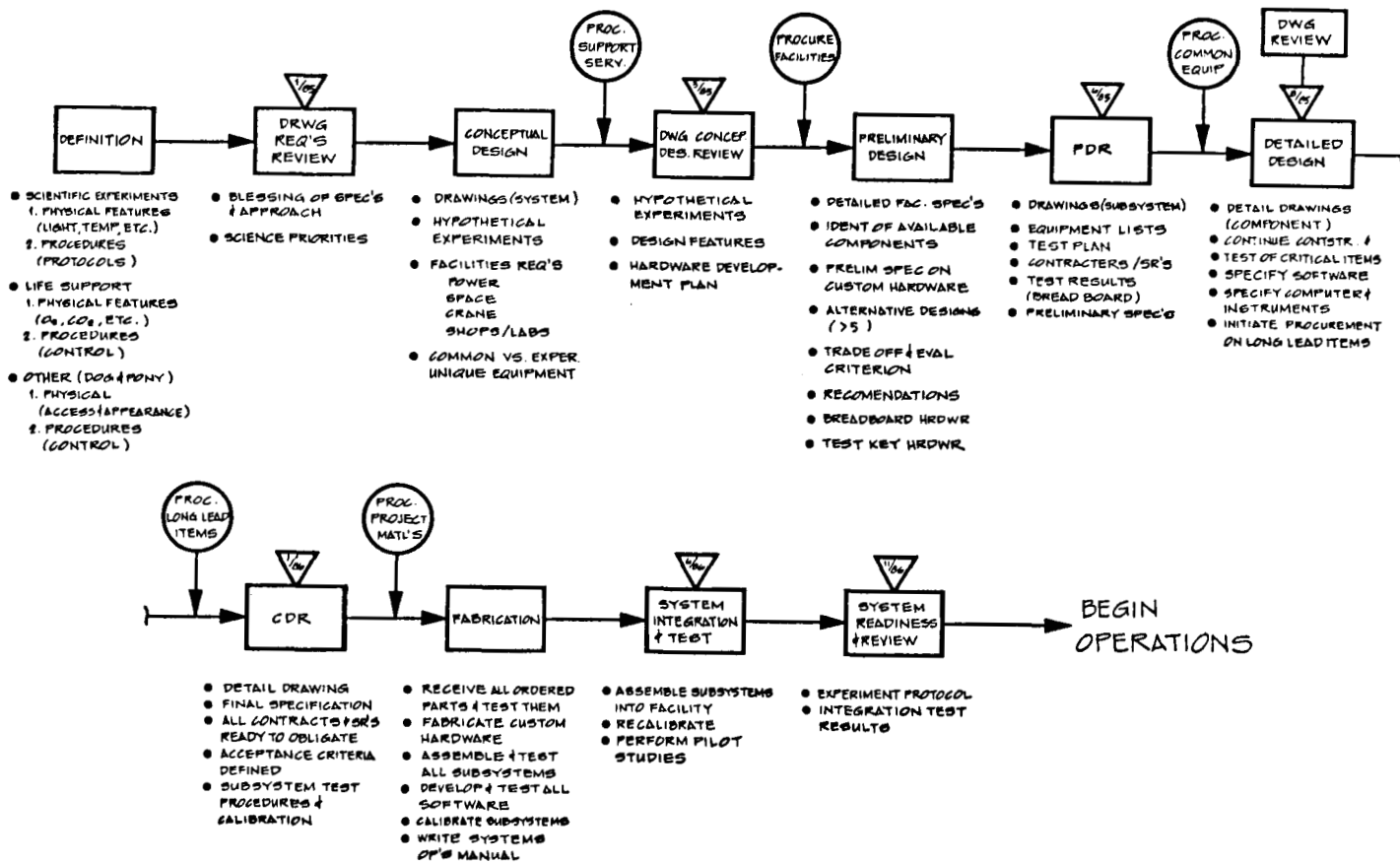

APPENDIX

LIST OF ATTENDEES TO THE AMES PGM WORKSHOP
SEPTEMBER 1984

Name	Organization (1987)	Phone
Anderson, Larry	U. Wisconsin	608-262-4900
Averner, Mel	NASA-HQ	202-453-1551
Arno, Roger	NASA-Ames	415-694-6640
Bates, Maynard	Campbell Inst. Res. Tech.	717-437-3263
Berry, Wade L.	UCLA	213-825-8774
Bredt, James H.	NASA-HQ	202-453-1540
Bugbee, Bruce	Utah State U.	801-750-2265
Garavelli, John S.	U. Illinois, Chicago	312-996-0796
Hansen, Dennis J.	NPI Salt Lake	801-582-0144
Hill, Ray A.	Morgan State U.	301-444-3295
Hoshizaki, Takashi	NASA-JPL	818-354-6962
Johnson, Richard D.	SRI International	415-859-2799
Langhans, Robert W.	Cornell U.	607-256-3139
MacElroy, Robert D.	NASA-Ames	415-694-5573
McFarlane, Craig	EPA-Corvallis, OR.	503-757-4620
McQuay, Newton	Duke U.	919-684-6523
Mitchell, Cary	Purdue U.	317-494-1347
Oleson, Mel	Boeing Aerospace	206-773-5188
Olson, Richard	Boeing Aerospace	206-773-3779
Raper, David	N. Carolina State U.	919-737-2644
Rummel, John D.	NASA-HQ	202-453-1535
Rasmussen, Daryl	NASA-Ames	415-694-6603
Sager, John	Smithsonian Env. Res. Inst.	301-443-6105
Schwartz, Mary	NASA-Ames	415-694-6525
Schwartzkopf, Steve	U. California, Davis NASA-Ames	415-694-6055
Smernoff, David T.	U. New Hampshire NASA-Ames	415-694-6486
Stickford, George	Battelle Columbus Labs.	614-424-4810
Tibbitts, Ted	U. Wisconsin	608-262-1816

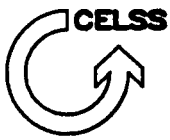

Controlled Ecological Life Support Systems (CELSS) A Bibliography of CELSS Documents Published as NASA Reports

1. Johnson, Emmett J.: Genetic Engineering Possibilities for CELSS: A Bibliography and Summary of Techniques. NASA CR-166306, March 1982.
2. Hornberger, G.M. and Rastetter, E.B.: Sensitivity Analysis as an Aid in Modelling and Control of (Poorly-Defined) Ecological Systems. NASA CR-166308, March 1982.
3. Tibbitts, T.W. and Alford, D.K.: Controlled Ecological life Support System: Use of Higher Plants. NASA CP-2231, May 1982.
4. Mason, R.M. and Carden, J.L.: Controlled Ecological Life Support System: Research and Development Guidelines. NASA CP-2232, May 1982.
5. Moore, B. and MacElroy, R.D.: Controlled Ecological Life Support System: Biological Problems. NASA CP-2233, May 1982.
6. Aroeste, H.: Application of Guided Inquiry System Technique (GIST) to Controlled Ecological Life Support Systems (CELSS). NASA CR-166312, January 1982.
7. Mason, R.M.: CELSS Scenario Analysis: Breakeven Calculation. NASA CR-166319, April 1980.
8. Hoff, J.E., Howe, J.M. and Mitchell, C.A.: Nutritional and Cultural Aspects of Plant Species Selection for a Controlled Ecological Life Support System. NASA CR-166324, March 1982.
9. Averner, M.: An Approach to the Mathematical Modelling of a Controlled Ecological Life Support System. NASA CR-166331, August 1981.
10. Maguire, B.: Literature Review of Human Carried Microbes' Interaction with Plants. NASA CR-166330, August 1980.
11. Howe, J.M. and Hoff, J.E.: Plant Diversity to Support Humans in a CELSS Ground-Based Demonstrator. NASA CR-166357, June 1982.
12. Young, G.: A Design Methodology for Nonlinear Systems Containing Parameter Uncertainty: Application to Nonlinear Controller Design. NASA CR-166358, May 1982.
13. Karel, M.: Evaluation of Engineering Foods for Controlled Ecological Life Support Systems (CELSS). NASA CR-166359, June 1982.
14. Stahr, J.D., Auslander, D.M., Spear, R.C. and Young, G.E.: An Approach to the Preliminary Evaluation of Closed-Ecological Life Support System (CELSS) Scenarios and Control Strategies. NASA CR-166368, July 1982.
15. Radmer, R., Ollinger, O., Venables, A. and Fernandez, E.: Algal Culture Studies Related to a Closed Ecological Life Support System (CELSS). NASA CR-166375, July 1982.
16. Auslander, D.M., Spear, R.C. and Young, G.E.: Application of Control Theory to Dynamic Systems Simulation. NASA CR-166383, August 1982.

17. Fong, F. and Funkhouser, E.A.: Air Pollutant Production by Algal Cell Cultures. NASA CR-166384, August 1982.
18. Ballou, E. V.: Mineral Separation and Recycle in a Controlled Ecological Life Support System (CELSS). NASA CR-166388, March 1982.
19. Moore, B., III, Wharton, R. A., Jr., and MacElroy, R.D.: Controlled Ecological Life Support System: First Principal Investigators Meeting. NASA CP-2247, December 1982.
20. Carden, J. L. and Browner, R.: Preparation and Analysis of Standardized Waste Samples for Controlled Ecological Life Support Systems (CELSS). NASA CR-166392, August 1982.
21. Huffaker, R. C., Rains, D. W. and Qualset, C. O.: Utilization of Urea, Ammonia, Nitrite, and Nitrate by Crop Plants in a Controlled Ecological Life Support System (CELSS). NASA-CR 166417, October 1982.
22. Gustan, E. and Vinopal, T.: Controlled Ecological Life Support System: Transportation Analysis. NASA CR-166420, November 1982.
23. Raper, C. David, Jr.: Plant Growth in Controlled Environments in Response to Characteristics of Nutrient Solutions. NASA CR-166431, November 1982.
24. Wydeven, T.: Composition and Analysis of a Model Waste for a CELSS. NASA Technical Memorandum 84368, September 1983.
25. Averner, M., Karel, M., and Radmer, R.: Problems Associated with the use of Algae in Bioregenerative Life Support Systems. NASA CR-166615, November 1984.
26. Radmer, R., Behrens, P., Fernandez, E., Ollinger, O., Howell, C., Venables, A., Huggins, D. and Gladue, R.: Algal Culture Studies Related to a Closed Ecological Life Support System (CELSS). NASA CR-177322, October 1984.
27. Wheeler, R. and Tibbitts, T.: Controlled Ecological Life Support System: Higher Plant Flight Experiments. NASA CR-177323, November 1984.
28. Auslander, D., Spear, R., Babcock, P. and Nadel, M.: Control and Modeling of a CELSS (Controlled Ecological Life Support System). NASA CR-177324, November 1984.
29. Karel, M. and Kamarei, A.R.: Feasibility of Producing a Range of Food Products from a Limited Range of Undifferentiated Major Food Components. NASA CR-177329, April 1984.
30. MacElroy, R.D., Smernoff, D.T., and Klein, H.: Life Support Systems in Space Travel. (Topical Session of XXVth COSPAR meeting, Graz, Austria) NASA CP-2378, May 1985.
31. MacElroy, R.D., Martello, N.V., Smernoff, D.T.: Controlled Ecological Life Support Systems: CELSS '85 Workshop, NASA TM-88215, January 1986.
32. Tibbitts, T.W.: Controlled Environment Life Support System: Calcium-Related Leaf Injuries on Plants. NASA CR-177399, March 1986.
33. Tibbitts, T.W., Wheeler, R.M.: Controlled Environment Life Support System: Growth Studies with Potatoes, NASA CR-177400, March 1986.

34. Babcock, P.S.: Nonlinear System Controller Design Based on Domain of Attraction: An Application to CELSS Analysis and Control, NASA CR-177401, March 1986.
35. Smernoff, D.T.: Atmosphere Stabilization and Element Recycle in an Experimental Mouse-Algal System, NASA CR-177402, March 1986.
36. Oleson, M., Olson, R.L.: Controlled Ecological Life Support Systems (CELSS): Conceptual Design Option Study, NASA CR-177421, August 1986.
37. Oleson, M., Slavin, F., Liening, R., Olson, R.: Controlled Ecological Life Support Systems (CELSS): Physiochemical Waste Management Systems Evaluation, NASA CR-177422, August 1986.
38. Knox, J.: A Method of Variable Spacing for Controlled Plant Growth Systems in Spaceflight and Terrestrial Agriculture Applications, NASA CR-177447, February 1987.
39. Radmer, P., Arnett, K., Gladue, R., Cox, J., Lieberman, D.: Algal Culture Studies for CELSS, NASA CR-177448, February 1987.
40. Karel, M., Nakhost, Z.: Utilization of Non-Conventional Systems for Conversion of Biomass to Food Components, NASA CR-177449, February 1987.
41. MacElroy, R.D. . Smernoff, D.T., Rummel, J.: Controlled Ecological Life Support Systems: Design, Development and Use of a Ground-Based Plant Growth Module, NASA CP-2479, June 1987.
42. MacElroy, R.D. . Smernoff, D.T.: Regenerative Life Support Systems in Space, (Topical Session of XXVIth COSPAR meeting, Toulouse, France), NASA CP-2480, June 1987.

1. Report No. NASA CP-2479		2. Government Accession No.		3. Recipient's Catalog No.	
4. Title and Subtitle Controlled Ecological Life Support Systems: Design, Development, and Use of a Ground-based Plant Growth Module				5. Report Date September 1987	
				6. Performing Organization Code	
7. Author(s) Editors Robert D. MacElroy, David T. Smernoff, and John D. Rummel				8. Performing Organization Report No. A-87255	
				10. Work Unit No.	
9. Performing Organization Name and Address Ames Research Center Moffett Field, CA 94035-5000				11. Contract or Grant No. NCC2-27	
				13. Type of Report and Period Covered Conference Publication	
12. Sponsoring Agency Name and Address National Aeronautics and Space Administration Washington, DC 20546-0001				14. Sponsoring Agency Code 199-61-12	
15. Supplementary Notes Point of Contact: Technical Monitor, Robert D. MacElroy, Ames Research Center, MS 239-4, Moffett Field, CA 94035-5000 (415)694-5573 or FTS 464-5573					
16. Abstract <p>This report summarizes a series of meetings convened to address problems of food production by higher plants. The meetings involved scientists of the NASA CELSS program. The first meeting was convened to define experimentation requirements and the equipment necessary for the design of an experimental CELSS plant growth module. The second meeting provided a framework for the design of laboratory-sized plant growth chambers. The third meeting evaluated the rationale for the development of an informal collaborative effort between investigators from universities and industry and those at Ames Research Center. The meetings resulted in the identification of scientific requirements for specialized laboratory-sized research devices for the investigation of higher plant growth, the preliminary design of specific laboratory equipment needed for investigations, and the identification of specific research problems appropriate to collaborative research efforts.</p>					
17. Key Words (Suggested by Author(s)) Controlled Environment Agriculture (CEA) Plant productivity Closed ecosystems CELSS			18. Distribution Statement Unclassified - Unlimited Subject category - 54		
19. Security Classif. (of this report) Unclassified		20. Security Classif. (of this page) Unclassified		21. No. of pages 80	22. Price A04