

N88-14937

LOW-DISTURBANCE WIND TUNNELS

511-09

117235
15P.

I. E. Beckwith, Z. T. Applin,
P. C. Stainback and L. Maestrello
NASA Langley Research Center
Hampton, Virginia



Abstract

During the past several years, there has been an extensive program under way at the Langley Research Center to upgrade the flow quality in several of our large wind tunnels. This effort has resulted in significant improvements in flow quality in these tunnels and has also increased our understanding of how and where changes in existing and new wind tunnels are most likely to yield the desired improvements. As part of this ongoing program, flow disturbance levels and spectra have been measured in several Langley tunnels before and after modifications were made to reduce acoustic and vorticity fluctuations. A brief description of these disturbance control features is given for the Low-Turbulence Pressure Tunnel, the 4- x 7-Meter Tunnel, and the 8-Ft Transonic Pressure Tunnel. These tunnels cover the speed range from low subsonic to transonic. To illustrate typical reductions in disturbance levels obtained in these tunnels, data from hot-wire or acoustic sensors are presented.

A new concept for a subsonic quiet tunnel designed to study boundary-layer stability and transition is also presented. This tunnel avoids some of the disturbance sources in continuous circuit tunnels and also utilizes some special features to reduce fan noise.

Techniques developed at Langley in recent years to eliminate the high intensity and high-frequency acoustic disturbances present in all previous supersonic wind tunnels are described. Freestream measurements of disturbance levels in a Mach 3.5 pilot tunnel which utilizes these techniques are discussed. Data obtained in this tunnel for transition from laminar to turbulent boundary layer on a cone are compared with previous wind tunnel and flight data.

In conclusion, the low-disturbance levels present in atmospheric flight can now be simulated in wind tunnels over the speed range from low subsonic through high supersonic. The special problems that must be solved to reduce flow disturbances in hypersonic wind tunnels will not be considered in this paper.

INTRODUCTION

- DISTURBANCE LEVELS AND SPECTRA MEASURED IN SEVERAL LANGLEY TUNNELS BEFORE AND AFTER MODIFICATIONS/IMPROVEMENTS
- WHAT ARE FEATURES OF THESE TUNNELS REQUIRED TO REDUCE DISTURBANCES OVER SPEED RANGE?
 - LOW-TURBULENCE PRESSURE TUNNEL
 - 4-X 7-METER TUNNEL
 - 8-FT TRANSONIC PRESSURE TUNNEL
 - SUBSONIC QUIET TUNNEL: A CONCEPT
 - MACH 3.5 LOW-DISTURBANCE TUNNEL

Low-Turbulence Pressure Tunnel

The Langley Low-Turbulence Pressure Tunnel was designed especially for research on wing sections. A low-turbulence airstream was required for systematic investigations of large numbers of airfoils at flight Reynolds numbers. The tunnel is of welded steel construction to permit operation at pressures up to 10 atmospheres.

The principal features of this tunnel that account for the low-turbulence levels are, moving upstream from the test section: the relatively large contraction ratio; the nine screens; the heating/cooling coils which function as a honeycomb; the lack of any 90° elbows in the flow circuit along with the splitter vanes and guiding vanes to control separation; and the well-designed drive section and diffuser. This tunnel underwent a major overhaul between December 1979 and March 1982. Two of the major items replaced were the cooler and screens.

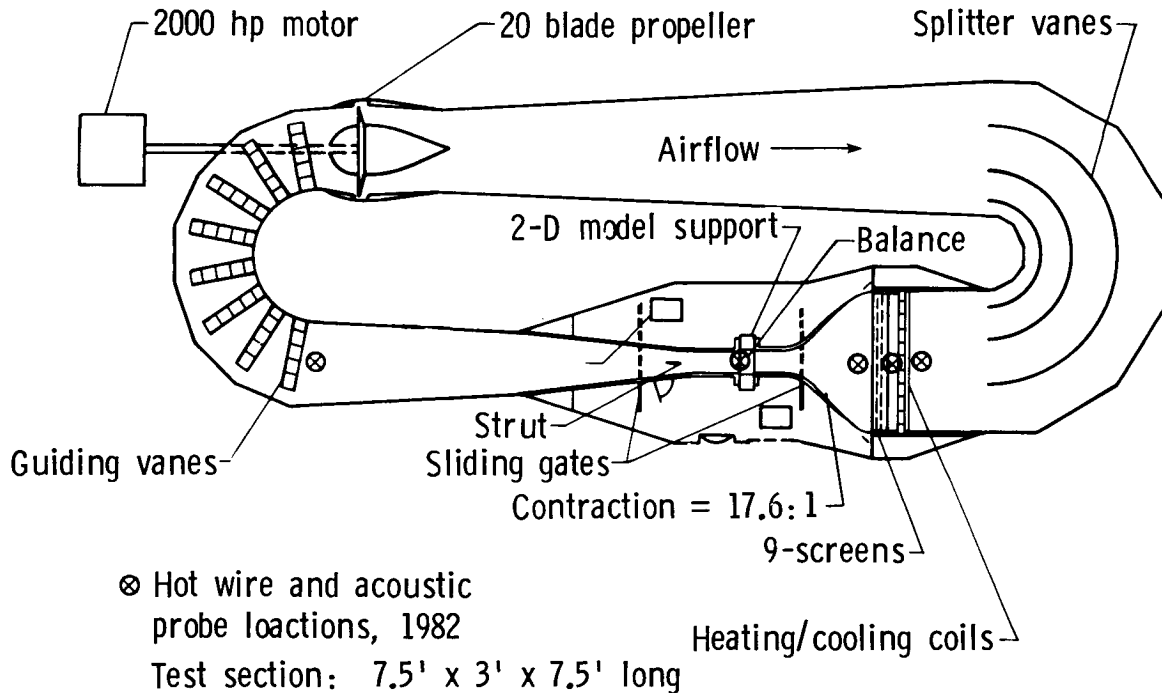

RMS Velocity Fluctuations in LTPT Test Section

Shown here are the rms velocity fluctuations normalized by the mean velocity (usually referred to as the "turbulence") plotted against the unit Reynolds number. These data were obtained with a hot-wire probe in the center of the test section. The new data obtained in 1982 (ref. 1) are for a range of Mach numbers from 0.05 to 0.3 and indicate the turbulence level generally increases with increasing Mach number. The increasing levels at high unit Reynolds numbers are caused by noise from the fan due to increased power, while the increased levels at the lower unit Reynolds numbers may be due to diffuser separation noise propagating upstream (see ref. 1). The agreement between the new data and the old 1941 data is excellent except for the low point which was for $M_\infty \approx .02$. Extrapolation of the new data to this value of M_∞ would give a turbulence level somewhat below the old level.

We conclude that correct design features for low-disturbance wind tunnels in this Mach number range were developed and applied successfully more than 45 years ago. Special acoustic treatment such as used for the Subsonic Quiet Tunnel (considered later in this paper) would probably reduce turbulence levels at the upper and lower ends of the Reynolds number range.

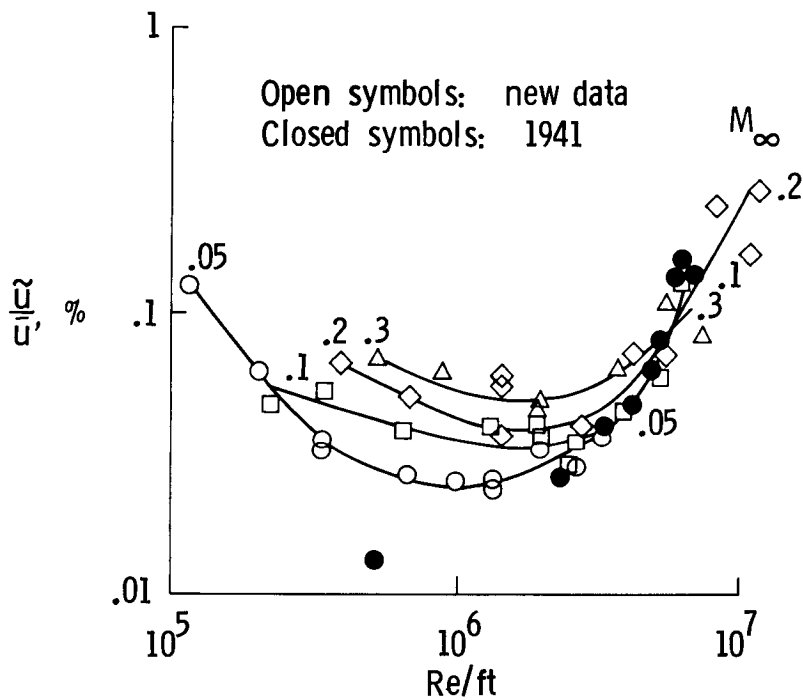

(Ref. 1)

The 4- by 7-Meter Tunnel

The Langley 4- by 7-Meter Tunnel (formerly the V/STOL Tunnel) is used for testing the subsonic aerodynamic characteristics of all types of aircraft, from rotorcraft to the Space Shuttle. Speeds up to 200 knots with unit Reynolds numbers up to $2.1 \times 10^6/\text{ft}$ can be obtained. The tunnel can be operated with closed test section walls (which may be slotted) or with one or more open test section configurations by raising the sidewalls and ceiling. The open test section configuration is particularly useful for flow visualization and acoustic measurements. Earlier investigations (reported in refs. 2 - 4) revealed that the flow quality in the original tunnel suffered from the effects of large-scale unsteadiness and intermittent flow separation in the diffuser downstream of the fan. These disturbances were convected around the circuit with additional input from the fan and flow separations around the third and fourth corners. In addition, for the open test section, the flow quality also suffered due to low-frequency flow pulsations caused by the original flow collector design. The closed test section flow quality has been improved by eliminating the large areas of flow separation by the addition of flow deflectors and replacement of the original debris screen which was too dense. A major facility upgrading is now in progress which includes a perforated grid, honeycomb and screens designed to further improve the test section flow quality. The flow pulsation problem in the open test section has been significantly reduced by triangular vanes and a new flow collector design, tested as a mock-up. A new, permanent flow collector has also been included in the facility upgrade to improve the open test section flow quality.

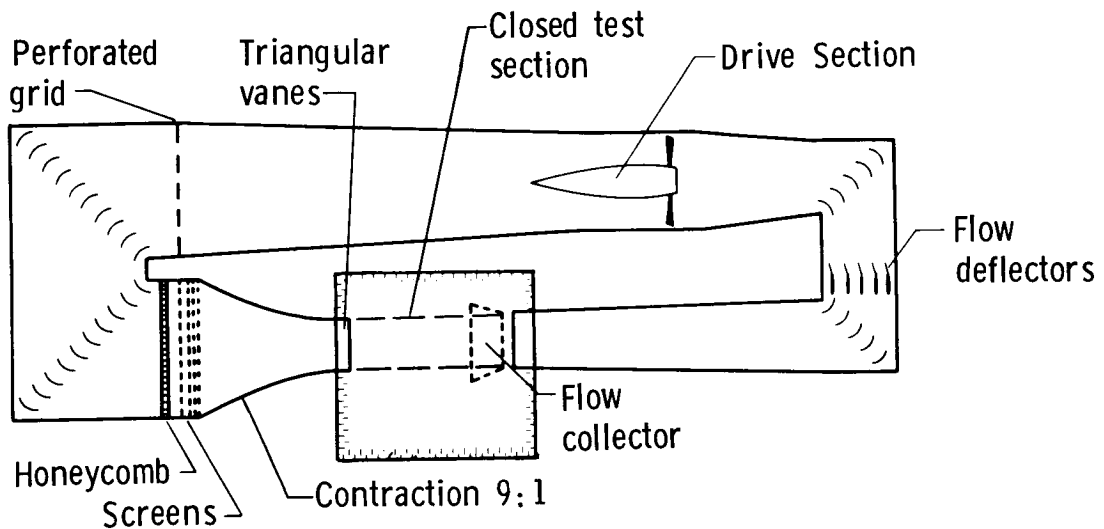

Velocity Fluctuations in the 4- by 7-Meter Tunnel

Shown here are the variations with unit Reynolds number of turbulence levels measured with a hot-wire probe in the center of the test section. Data in the open and closed test sections as obtained in both the original tunnel and with the modifications indicated are given. Nearly an order of magnitude reduction of the low-frequency turbulence levels in the open test section were obtained with the vanes and flow collector. For the closed test section, the original levels were reduced about 50 percent by the flow deflectors (which reduced separation effects) and the new much lower density debris screen. Further reductions are expected with the new perforated plate, honeycomb, and turbulence screens.

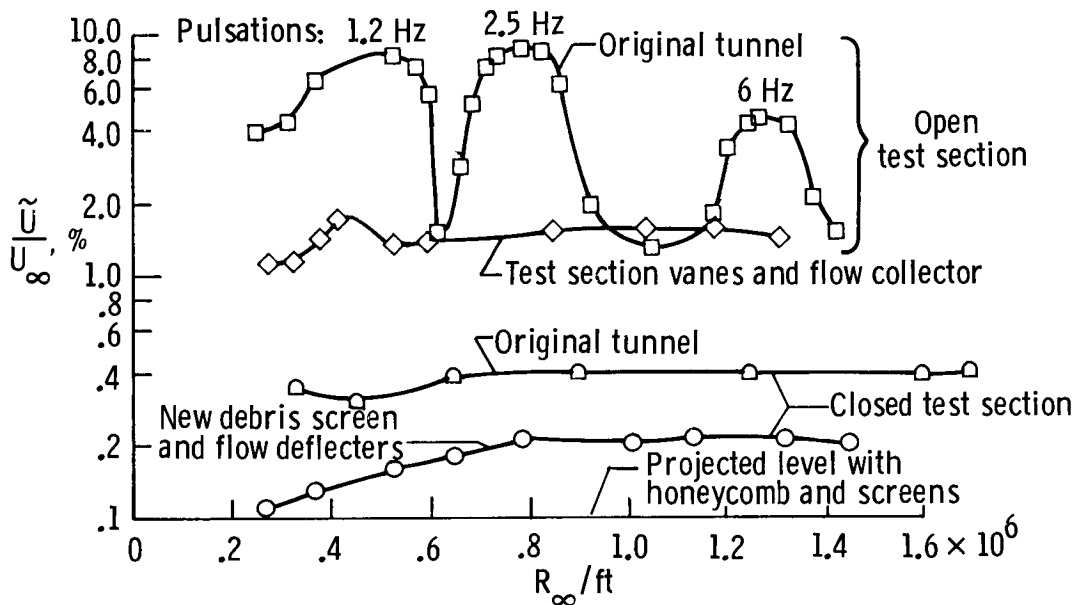

(Ref. 3)

The 8-Ft Transonic Pressure Tunnel

This tunnel has a rectangular cross section with slotted top and bottom walls. The cooler consists of eight staggered rows of finned tubes and it is located just upstream of the 36-Ft diameter settling chamber. Both hot-wire and acoustic probe data have been obtained (refs. 2 and 5) at the indicated locations. These measurements were made in preparation for extensive laminar flow control tests of a large wing (ref. 6). During these latter tests, a honeycomb and five screens were installed upstream of the contraction. However, fluctuation data obtained in the test section with the honeycomb and screens installed are not yet available.

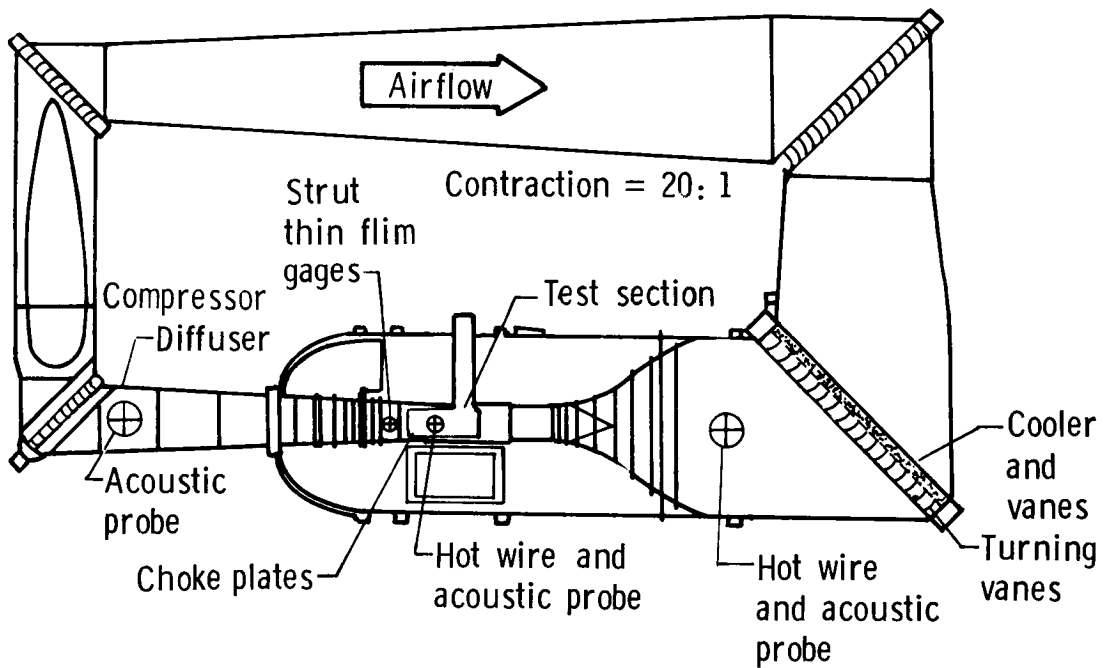

Pressure Fluctuations in Test Section of 8-Ft TPT

This figure shows the variation with Mach number of the rms static pressure normalized by the mean-static pressure on the centerline of the test section. High-frequency response pressure transducers, cavity mounted within ogive-cylinder probes were used to measure the fluctuating static pressures (ref. 2). For this investigation, the wall slots were covered with 0.25-inch thick metal plates which were beveled and mounted over the slots.

Data are shown for three different choke conditions. With no added chokes, sonic flow was reached near the exit of the test section. The rms pressures then dropped by an order of magnitude since pressure disturbances from the diffuser could not be transmitted upstream through the sonic region. The chokes used for this investigation consisted of streamlined plates that were 3-3/4 feet long by one-inch thick at their location of maximum camber. One side of the plates was flat and this side was attached to the wall with the plate leading edges 5-3/4 feet from the test section entrance. With two of the plates attached to opposite sides of the tunnel, sonic flow occurred at the plate location when the upstream test section Mach number, $M_\infty \approx .85$. With all four plates attached, the choked condition was reached when $M_\infty \approx .78$. For all of these choked conditions, the noise level approached the estimated values (ref. 5) caused by the turbulent wall boundary layers. This lower level presumably represents essentially the minimum possible in this type and size of tunnel.

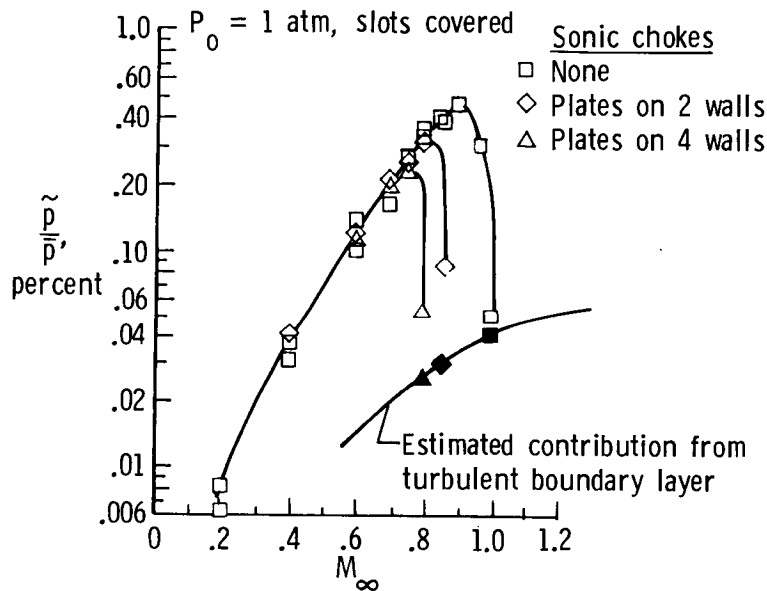

(Ref. 2)

Subsonic Quiet Tunnel

A quiet, high flow quality, transition research apparatus is being designed by L. Maestrello of NASA Langley to study problems of stability, transition, and methods of transition control. The apparatus is open circuit with a 3 x 3-ft test section and a contraction ratio of 20:1. It will operate at speeds up to 240 ft/sec with a corresponding unit Reynolds number of 10^6 . Boundary-layer control by suction will be applied on the walls of the contraction and the test section. It is powered by four quiet synchronous fan-motor assemblies with a specially designed variable impedance acoustic muffler placed downstream of the test section. The settling chamber will contain several turbulence screens preceded by a honeycomb-type device consisting of thin-wall tubes aligned with the flow. The facility will be capable of simulating various physical phenomena associated with boundary-layer transition and active control.

The noise from the fan-motor assembly propagating upstream into the test section is attenuated by the specially designed acoustic muffler. The muffler is lined with variable density sound absorbing material of progressively varying depth to provide sound attenuation over a broad range of frequencies. The inside walls of the muffler are slightly diverging to act as a diffuser as well. Estimated noise levels at the highest speed using a 15-Ft long muffler on two or three sides of the diffuser duct are shown. These noise levels are based on experimental data from similar configurations. The noise level obtained with the three-sided muffler is lower than the estimated flow noise in the test section.

Research on Stability, Transition, and Transition Control

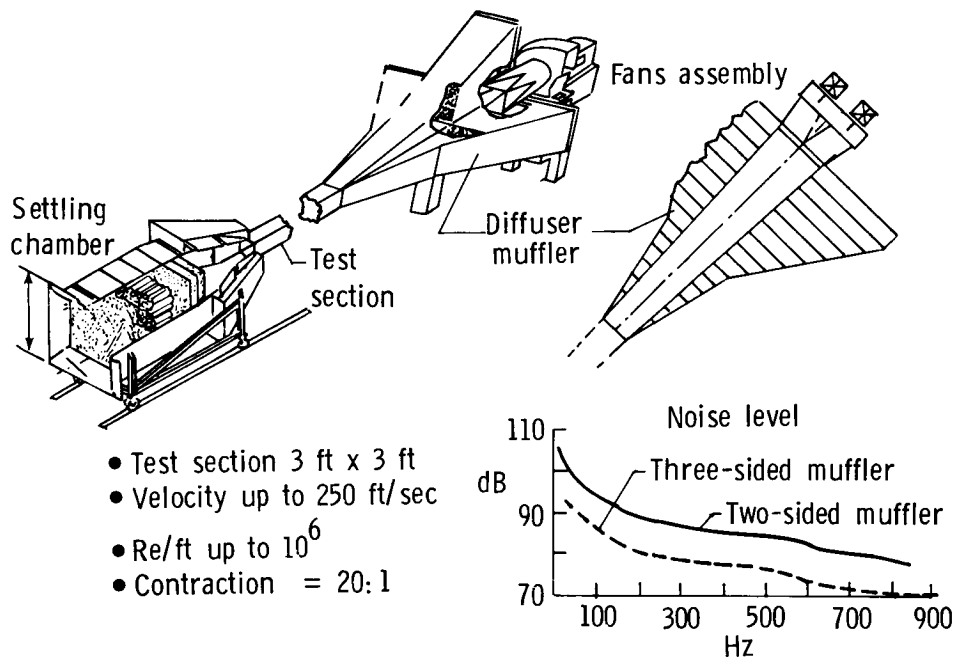

Supersonic Low-Disturbance Tunnel

This figure shows a cross-sectional view of the two-dimensional Mach 3.5 Pilot Nozzle. This small nozzle has exit dimensions of 6 inches high by 10 inches wide and it is installed in a blow-down facility at Langley that has been used over the past several years to develop and test techniques for reducing flow noise at Mach numbers of 3 and 3.5 (refs. 7-9).

The settling chamber is 2 feet in diameter and contains a honeycomb, 7 turbulence screens, and acoustic attenuators consisting of dense porous plates that reduce the high valve and pipe noise to very low levels.

The subsonic approach to the nozzle has a contraction ratio of 49 and has boundary-layer removal slots upstream of the throat as indicated. In this way the new laminar boundary that begins at the slot lip can be maintained laminar to appreciable downstream distances into the supersonic flow. When the nozzle wall boundary layers are laminar, the very high level and high-frequency noise radiated into the test section by the turbulent wall boundary layers in conventional supersonic tunnels is eliminated. The large favorable pressure gradients and highly polished walls help maintain the nozzle wall boundary layers laminar up to unit Reynolds numbers of $6 \times 10^7/\text{m}$ (ref. 8) where the freestream test Reynolds number based on the length of the quiet test region is approximately 7×10^6 . Consequently, as illustrated, the upstream most sensitive regions of the laminar boundary layer on a test cone have essentially no incident noise, and transition Reynolds numbers are in the range of flight data.

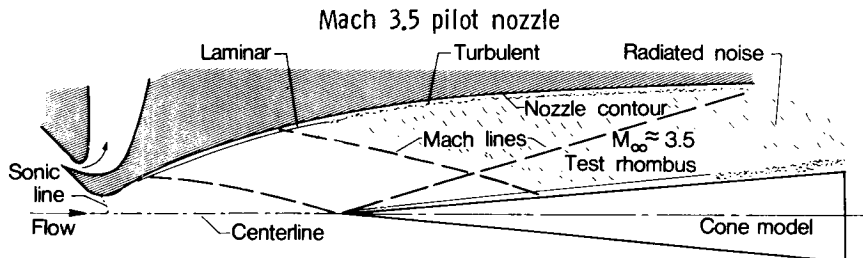

- Blow-down tunnel - high valve and pipe noise
- Settling chamber treatment
- Subsonic boundary-layer removal
- Highly polished walls
- Laminar boundary layer on nozzle walls
- Laminar to turbulent transition on test models same as flight data
- Incident noise can be varied

Effect of Unit Reynolds Number on Noise in Pilot Nozzle

The rms static pressures (normalized by the mean pressures) obtained from hot-wire data on the nozzle centerline are plotted against distance from the nozzle throat. Since acoustic noise is propagated along Mach lines in supersonic flow, the noise levels in the test rhombus are extremely low (within the instrument noise range) when the boundary layer at the upstream acoustic origin regions is laminar. For the lowest unit Reynolds number of $R = 2.5 \times 10^6/\text{in}$, the acoustic origin location at transition on the nozzle wall is indicated and the corresponding locus of the increased noise levels is traced along a Mach line downstream to the centerline. When the probe is traversed through this centerline station, the increased noise is sensed by the hot-wire anemometer. Also, when the test unit Reynolds number is increased, transition on the nozzle wall moves upstream and the length of the quiet test core is correspondingly reduced.

Since, at a given Reynolds number the upstream "edge" of the increasing noise region is fixed within the nozzle flow field, the noise levels and onset locations can be varied, as desired, by simply moving the cone downstream within the uniform test flow rhombus. Obviously, the noise onset regions and levels can also be varied by changing the unit Reynolds number. Another technique that has been used extensively to increase the noise levels (ref. 7), is to cut off the subsonic boundary-layer removal flow (see previous figure) with a valve in the exhaust ducts. The result is that the flow spills around the slot lip and the boundary layer on the nozzle walls is then completely turbulent.

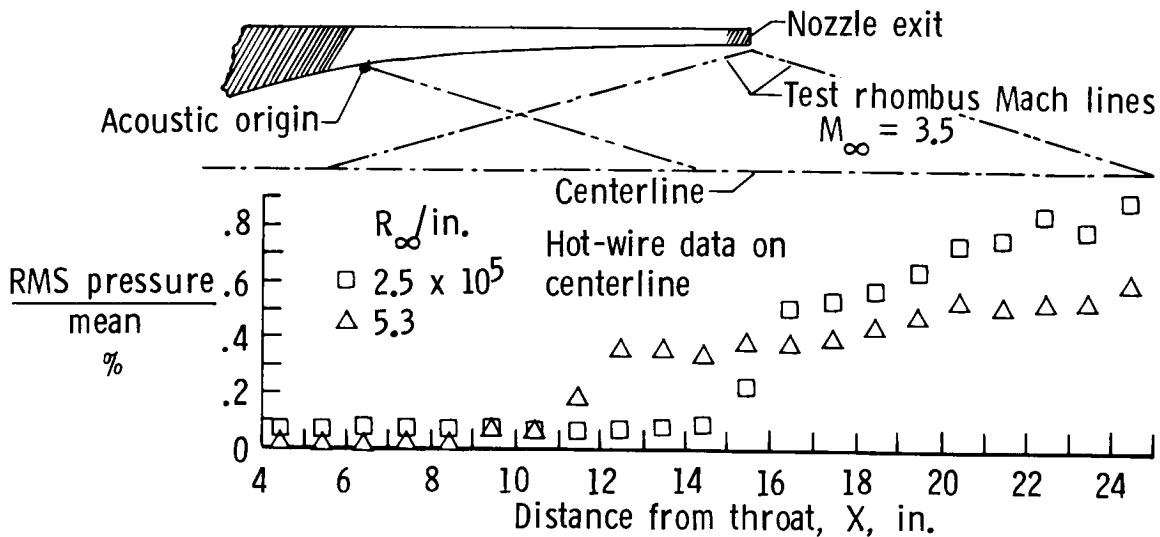

Transition Reynolds Numbers on Sharp Cones

This final figure compares the transition Reynolds numbers, Re_T , (the local length Reynolds numbers at the onset location of transition) on sharp tip cones at zero angle of attack from the present quiet tunnel tests with flight data and conventional wind tunnel data. The data are plotted with the familiar parameters of Re_T against the local unit Reynolds number, Re/in . In the range of 5 to $8 \times 10^5/in$, the quiet tunnel data are much higher than data from conventional tunnels and are in the lower range of the flight data. As Re/in is increased above 8×10^5 , the values of Re_T decrease into the range (extrapolated) of the conventional tunnel data. This decrease in Re_T is caused by the corresponding increasing noise levels as illustrated in the previous figure.

It has been discovered that the location of transition on the nozzle wall depends also on the surface finish of the wall. Hence, according to the previous discussion, the location of transition on a test cone would also be affected. This dependence of Re_T on the nozzle surface finish is shown in the figure by data taken before and after extensive polish work on the nozzle surface. The μ -inch finish values given are the highest rms values obtained with a profilometer in the same regions near the nozzle throat. Thus, at $Re \approx 10^6/in$, the values of Re_T were increased from 4×10^6 up to 8×10^6 by the improved nozzle wall finish from 12 rms μ -inch to 3 rms μ -inch.

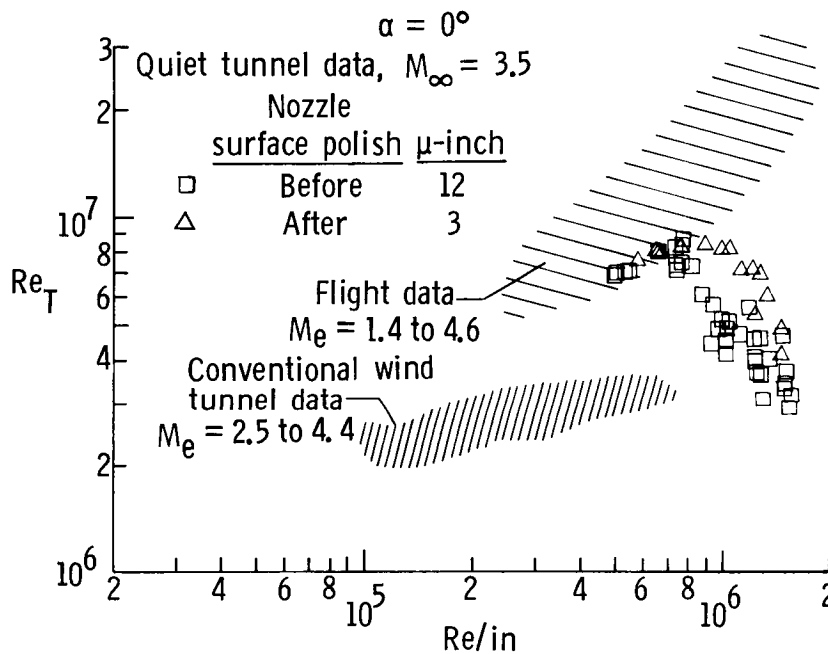

Conclusions

The general requirements for low-disturbance wind tunnels include:

Subsonic and Transonic Tunnels

- a. Layout of circuit, turning vanes and diffuser: control separation
- b. Acoustic treatment of drive section and diffuser
- c. Honeycomb and screens
- d. High contraction ratio
- e. Sonic chokes
- f. Open test section: treatment of entrance and exit

Supersonic Blow-Down Tunnel

- a. Settling chamber acoustic components to reduce valve and pipe noise
- b. Subsonic boundary layer removal
- c. Highly polished walls
- d. Laminar boundary layer on nozzle walls

Results

Practical techniques developed at Langley have significantly reduced disturbances in wind tunnels up to Mach number 3.5. The low-disturbance levels of flight can be simulated in wind tunnels over the speed range.

References

1. Stainback, P. Calvin and Owen, F. Kevin: Dynamic Flow Quality Measurements in the Langley Low-Turbulence Pressure Tunnel. AIAA Paper 84-0621, March 1984.
2. Owen, F. K.; Stainback, P. C.; and Harvey, W. D.: An Evaluation of Factors Affecting the Flow Quality in Wind Tunnels. AGARD-CP-348, February 1984.
3. Applin, Zachary T.: Modification to the NASA Langley 4- by 7-Meter Tunnel for Improved Rotorcraft Aerodynamics and Acoustics. Presented at the American Helicopter Society Meeting in Williamsburg, Virginia, Oct. 29-Nov. 1, 1984.
4. Sellers, William L., III; Applin, Zachary T.; Molloy, John K.; and Gentry, Garl L., Jr.: Effect of Jet Exit Vanes on Flow Pulsations in an Open-Jet Wind Tunnel. NASA TM 86299, March 1985.
5. Harvey, William D.; Stainback, P. Calvin; and Owen, F. Kevin: Evaluation of Flow Quality in Two Large NASA Wind Tunnels at Transonic Speeds. NASA Technical Paper 1737, Dec. 1980.
6. Harvey, W. D.; Harris, C. D.; Brooks, C. W.; Clukey, P. G.; and Stack, J. P.: Design and Experimental Evaluation of a Swept Supercritical Laminar Flow Control (LFC) Airfoil. NASA CP-2397, 1986. (Paper 26 in this compilation.)
7. Beckwith, Ivan E.; Creel, Theodore R., Jr.; Chen, Fang-Jenq; and Kendall, James M.: Free-Stream Noise and Transition Measurements on a Cone in a Mach 3.5 Pilot Low-Disturbance Tunnel. NASA Technical Paper 2180, September 1983.
8. Beckwith, I. E.; Malik, M. R.; and Chen, F.-J.: Nozzle Optimization Study for Quiet Supersonic Wind Tunnels. AIAA Paper 84-1628, June 1984.
9. Chen, F.-J.; Malik, M. R.; and Beckwith, I. E.: Instabilities and Transition in the Wall Boundary Layers of Low-Disturbance Supersonic Nozzles. AIAA Paper 85-1573. Presented at the AIAA 18th Fluid Dynamics, Plasma Dynamics, and Lasers Conference, Cincinnati, Ohio, July 16-18, 1985.