

N88-14946

520-02
117244
79.

OVERVIEW OF THE LANGLEY VISCOUS DRAG REDUCTION PROGRAM

**Jerry N. Hefner
NASA Langley Research Center
Hampton, Virginia**

VISCOUS DRAG REDUCTION

As a result of reductions in form drag and roughness drag, skin friction drag or viscous drag now represents a major contributor to the cruise drag of subsonic business and transport aircraft, and hence, is considered a barrier problem to further significant improvements in the aerodynamic efficiency of these aircraft. In fact, viscous drag accounts for as much as 50 percent of the total cruise drag for subsonic transports and as much as 35-40 percent of the cruise drag for supersonic aircraft. To meet the challenge of reduced viscous drag and improved aerodynamic efficiency, research in the areas of laminar-flow control and turbulence control/drag reduction was initiated at the NASA Langley Research Center in the mid-1970's under the Aircraft Energy Efficiency Program and the Aeronautics Research and Technology Base. The significance of this research is that even small reductions in viscous drag should provide important design tradeoffs including: significant resizing options for new aircraft designs, increased range capability without increased take-off gross weight, increased speed and productivity, and reduced fuel volume and cost. Only a 10-percent reduction in viscous drag could provide an annual fuel savings of the order of \$200-300 million assuming an annual civil aviation fuel bill in the United States of \$10 billion.

- Viscous (skin friction) drag is barrier problem
- Accounts for approximately
 - 50 percent of cruise drag for subsonic transports
 - 35-40 percent for supersonic aircraft
- Reductions in viscous drag provide
 - Significant re-sizing options for new aircraft designs
 - Increased range capability
 - Increased speed and productivity
 - Reduced fuel volume/cost

MAINTENANCE OF LAMINAR FLOW FOR VISCOUS DRAG REDUCTION

The research being conducted under the Viscous Drag Reduction Program focuses on two approaches to reduce the skin friction drag. Where the chord or length Reynolds numbers (R_c) are of the order of 60×10^6 or less (i.e., wings, nacelles, empennage), the maintenance of laminar flow appears most promising and provides the largest net benefits. For Reynolds numbers much larger than this (i.e., 100×10^6 or greater), it is unclear whether laminar flow can be maintained over relatively large surface areas of the aircraft; hence, turbulence control/drag reduction is being investigated for these surfaces (i.e., fuselage).

Three concepts are being investigated to delay the boundary layer transition process and maintain laminar flow beyond the usual transition Reynolds numbers of 4×10^6 or less. These include: (1) the use of favorable pressure gradient or surface shaping (natural laminar flow); (2) suction through slotted or perforated surfaces (laminar flow control); and, (3) combinations of suction and favorable pressure gradient (hybrid laminar flow control). The advantage of natural laminar flow is that it is a passive approach to the maintenance of laminar flow but it may be limited to wing sweep angles of approximately 20° or less and chord Reynolds numbers of 20×10^6 or less. Laminar-flow control, using full-chord suction, will probably be required for applications where extensive laminar flow is necessary for chord Reynolds numbers approaching $50\text{--}60 \times 10^6$ and sweep angles of 30° or greater. Hybrid laminar-flow control minimizes suction requirements and provides increased operational flexibility and improved off-design performance compared to natural laminar flow.

● Pressure gradient/shaping

● Suction through slotted or perforated surfaces

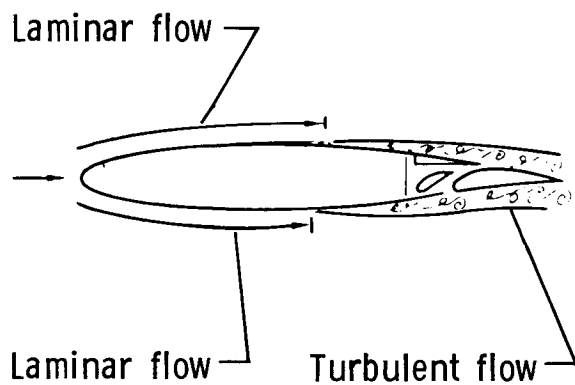

Natural Laminar Flow

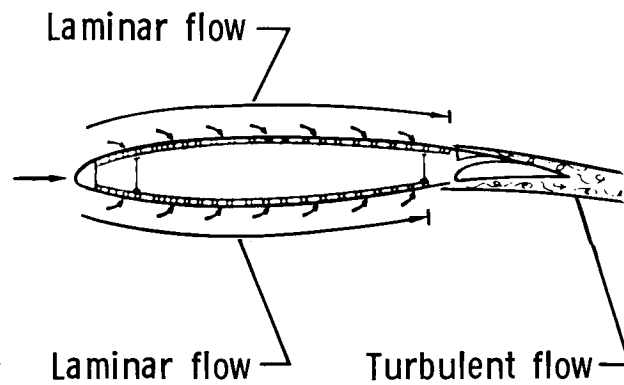

Laminar Flow Control

TURBULENCE CONTROL FOR VISCOUS DRAG REDUCTION

Turbulence control/drag reduction research attempts to identify and develop highly innovative concepts employing surface micro-geometry modifications to alter and control the turbulence production process and to reduce turbulent surface shear. Although the payoff from this approach to viscous drag reduction is generally much less than that for the maintenance of laminar flow, it does provide an alternative that is applicable to high length Reynolds numbers, may be retrofittable to existing aircraft, and has less operational sensitivities.

Twelve turbulence control concepts are currently being explored at Langley with two of these concepts (i.e., riblets and large-eddy breakup devices) producing net viscous drag reductions of the order of 10 percent. Riblets are very small, flow-aligned, triangular grooves cut into the surface. If the height and spacing of these grooves are scaled properly, based on particular fluid physics properties, then net skin-friction drag reductions can be obtained; for practical flight applications riblets would typically have a height and spacing of between 0.0015-0.003 inch. Large-eddy breakup devices are thin flat plates or small airfoils immersed within the turbulent boundary layer to alter the large-scale turbulent structures within the boundary layer. The unique feature of both concepts is that the skin-friction reductions produced by their interaction with the turbulent boundary layer are sufficiently large, such that they more than compensate for the drag penalties associated with the particular concept (i.e., increased wetted area for riblets and device drag for large-eddy breakup devices).

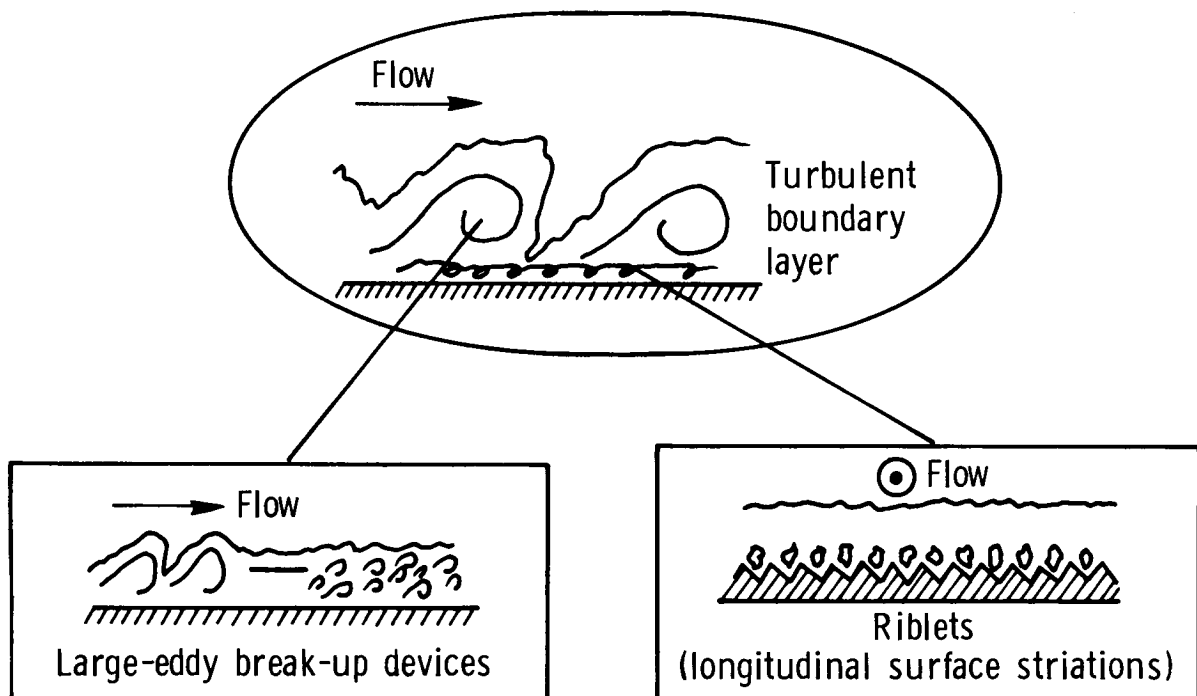

VISCOUS DRAG REDUCTION RESEARCH

Wind tunnel, flight, computational, and systems research programs are aimed at providing the data base and design methodology necessary to ensure the technology readiness of viscous drag reduction for the 1990's and to reduce the risks associated with both the near-term and far-term application to business, commuter, and transport aircraft. Other important objectives include: determining the limits of applicability of natural laminar flow with regard to wing sweep, pressure gradient, Reynolds number, and disturbance environment; providing the experience and data base to ensure that laminar flow can be maintained economically and reliably in practical airline environments; and demonstrating that turbulent drag reduction is more than a laboratory curiosity and can provide significant benefits in practical flight applications.

Objectives

- Data base and design methodology necessary to accelerate technology readiness and reduce risks for application to business, commuter, and transport aircraft
- Limits of applicability of natural laminar flow
- Economic maintenance and reliability of laminar-flow control concepts
- Flight application of turbulent drag reduction concepts

CURRENT VISCOUS DRAG REDUCTION RESEARCH

Key elements of the Viscous Drag Reduction Program are highlighted on this figure. Laminar flow research focuses on the following: developing advanced airfoils for all classes of aircraft, providing guidelines for fuselage and nacelle laminarization, determining allowable manufacturing tolerances, determining the acoustic environment on transport aircraft at cruise conditions including critical noise sources and their influence on the maintenance of laminar flow, understanding the fluid physics and providing a boundary layer transition criterion for the interaction of crossflow (CF) and Tollmien-Schlichting (TS) instabilities, establishing design criteria for perforated and slotted suction surfaces with improved tolerances to spanwise and chordwise pressure gradients, developing control concepts for separation on laminar-flow airfoils, and conducting systems research to explore the near-term application of hybrid laminar-flow control to transport aircraft. Turbulent drag reduction research focuses on concept invention and development, and the optimization and flight evaluation of riblets and large-eddy breakup devices.

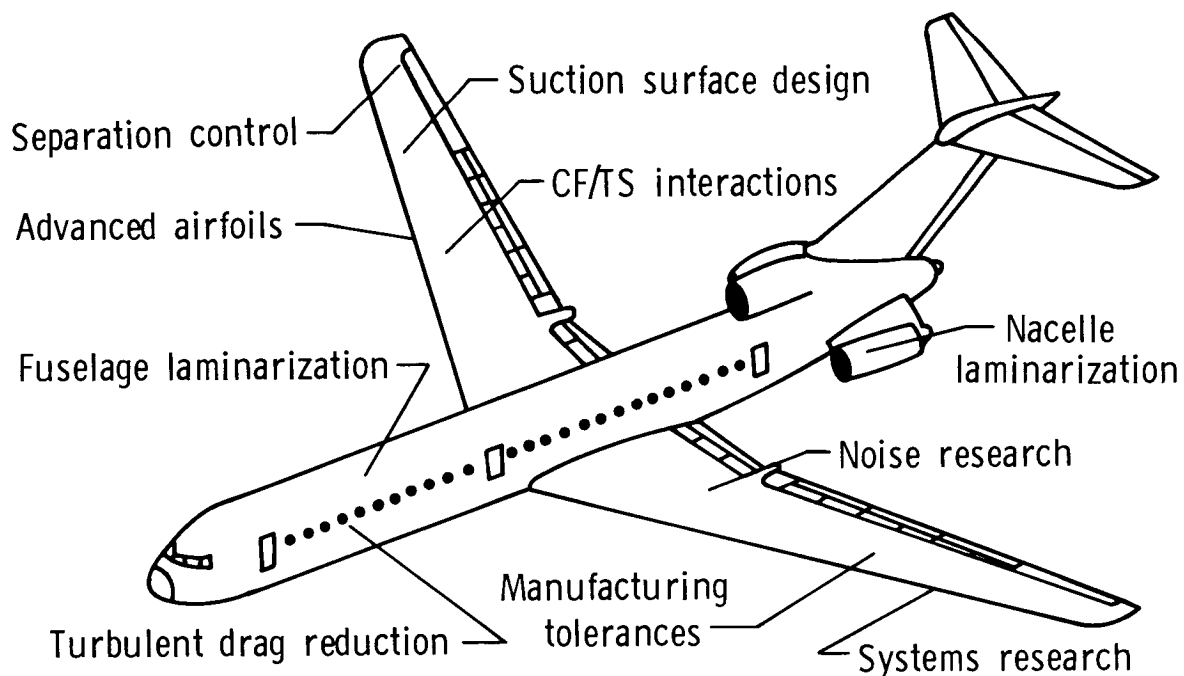

POTENTIAL PAYOFFS FOR VISCOUS DRAG REDUCTION APPROACHES

Significant progress has been made in the areas of natural laminar flow, laminar-flow control, and turbulent drag reduction over the past seven to ten years and viscous drag reduction is now recognized as one of the two technologies having the greatest potential for improving the performance of future aircraft (propulsion and the advanced turboprop constitute the other technology). Potential payoffs could include 15 percent reductions in cruise drag for natural laminar flow applied to only wing surfaces, 20 percent reductions for laminar-flow control wings, and 5-10 percent reductions for riblets and/or large-eddy breakup devices applied to transport fuselages. These payoffs would reduce fuel volume and cost, increase the sales of business and transport aircraft employing viscous drag reduction, and provide the technology for global military transports and for missiles and supercruisers with increased range.

- Natural laminar flow
 - Order of 15 percent reductions in aircraft drag
 - Greatly increased export sales; reduce fuel costs
- Laminar flow control (suction)
 - Order of 20 percent reductions in aircraft drag
 - \$2 billion/year in fuel savings
 - Global military transports
- Turbulent drag reduction
 - Order of 5-10 percent reductions in aircraft drag
 - \$700 million/year in fuel savings
 - Increased missile/supercruiser range