

NASA Technical Memorandum 100481

A SPACE TRANSPORTATION SYSTEM OPERATIONS MODEL

**(NASA-TM-100481) A SPACE TRANSPORTATION
SYSTEM OPERATIONS MODEL (NASA) 65 P
CSSL 22B**

N88-14999

**Unclas
G3/16 0118989**

**W. DOUGLAS MORRIS
NANCY H. WHITE**

DECEMBER 1987



**National Aeronautics and
Space Administration**

**Langley Research Center
Hampton, Virginia 23665**

TABLE OF CONTENTS

section		page
1.0.0	ABSTRACT	1
2.0.0	INTRODUCTION	1
3.0.0	GENERAL CONCEPT AND APPROACH	2
4.0.0	SYSTEM DESCRIPTION	4
4.1.0	BASE OPERATIONS	4
4.2.0	SPACE STATION OPERATIONS	5
4.3.0	ORBITAL OPERATIONS	6
5.0.0	MODEL DESCRIPTION	7
5.1.0	DATA FILE	7
5.2.0	NETWORK MODEL	8
5.2.1	BASE OPERATIONS	8
5.2.2	SPACE STATION OPERATIONS	10
5.2.3	ORBITAL OPERATIONS	13
5.3.0	FORTRAN EVENT FILE	13
6.0.0	PROGRAM DESCRIPTION	17
6.1.0	USAGE	17
6.2.0	EXAMPLE	17
7.0.0	CONCLUDING REMARKS	21
8.0.0	REFERENCES	22
9.0.0	FIGURES	23
9.1.0	FIG.-1 Transportation System Operating Scenario	24
9.2.0	FIG.-2 Schematic of the STS Operations Model	25
9.3.0	FIG.-3 Network Model	26
9.4.0	FIG.-4 Example of the Standard Output Report	31
9.5.0	FIG.-5 Sample User Generated Output	35
10.0.0	APPENDICES	38
10.1.0	APPENDIX A-DATA FILE LISTING	39
10.2.0	APPENDIX B-NETWORK LISTING	40
10.3.0	APPENDIX C-FORTRAN EVENT FILE LISTING	49

A SPACE TRANSPORTATION SYSTEM OPERATIONS MODEL

**W. DOUGLAS MORRIS
NANCY H. WHITE**

1. ABSTRACT

This paper presents a description of a computer program which allows assessment of the operational support requirements of space transportation systems in both a ground- and space-based environment. As presently configured, the scenario depicted provides for the delivery of payloads from Earth to a space station and beyond using upper stages based at the station. Model results are scenario dependent and rely on the input definitions of delivery requirements, task times, and available resources. Output is in terms of flight rate capabilities, resource requirements, and facility utilization. A general program description, program listing, input requirements, and sample output are included.

2. INTRODUCTION

The magnitude and diversity of the future space programs as envisioned in the President's commission on space report (ref. 1) have helped focus attention on the need for a method which will allow an evaluation of the operational as well as the performance characteristics of these systems well in advance of their development. Early recognition of the operational requirements and assessment of their effects on the transportation system provide the best opportunity of designing a system that is capable of effectively supporting the mission requirements at a minimum cost in resources and time. A space transportation system, like any large and complex system, is subject to constraints in its ability to deliver men and material, which may not become obvious unless viewed from a systems perspective. The refurbishment requirements, on orbit operations, sequencing, and timing of operations can greatly impact the availability of vehicles. One way to examine the complexity incurred by the impact of these constraints on a space transportation system is through the use of discrete event simulation modeling.

A discrete simulation model can be used to examine and assess the

interaction between the transportation system's design and operation. Modeling languages facilitate the development of models that emphasize the procedures and resources required in the operational processes and provide the capability to modify the model to reflect different operating scenarios. An early model designed to examine a space shuttle operational concept is described in reference 2. This model was developed prior to the present Shuttle design and operational concept and thus did not reflect the true complexity required for turnaround operations. Later models were developed to assist in Shuttle scheduling analysis; reference 3 is one of the few which has been documented. A more recent modeling example is illustrated in reference 4 of a conceptual two-stage, fully reusable rocket system designed to deliver men and material to a space station with emphasis on the ground handling operations. This model and the proximity operations model (ref. 5), which focuses on space station activities, form the genesis of the present work. Modeling of the transportation system in this manner is used to expose the critical operational areas and consider alternatives. It can also be used to determine the resource requirements of the system while operating under different mission loads in order to better anticipate the total capability of the system. System considerations related to maintainability, availability, system effectiveness, cost, and schedules are particularly amenable to a simulation approach (ref. 6).

This paper presents a description of a model of a space transportation system architecture which can serve as an aid in the decision making process. It incorporates ground facilities and activities, space station support activities, and on-orbit deployment and service of satellites. The model was developed using the Simulation Language for Alternative Modeling (SLAM) described in reference 7. Although developed specifically to study a shuttle-space station interface, the model can be used as the basis for more general studies with the user providing a specific code for the study areas of interest. Many of the major elements required for a transportation study have been included in the basic model for this purpose. The results achieved using this model should help define the delivery rate capability of the system, the support resources required, and the utilization of facilities and vehicles.

3. GENERAL CONCEPT AND APPROACH

The purpose of this study was to develop a computer model to assess the support operations required to satisfy the delivery requirements of future transportation systems. A discrete event model was developed to simulate the operating scenario, which is illustrated conceptually in figure 1 and

schematically in figure 2. The model consisted of three major modules for base operations, space station operations, and orbital operations. The system is driven by the delivery requirements to orbit. The use of a network model, figure 3, helps to visually illustrate the operational flow and makes it easier to change the model to fit different scenarios. The FORTRAN code used in the program was reserved for decision points too complex or mundane to conveniently model in the network and still retain its effectiveness as a visual image of the operational procedures represented in each scenario. Modeling flexibility and ease of expansion were considered of paramount importance in developing this tool. The model was developed to include most of the major programming features thought to be needed to examine the operations anticipated in future space transportation architectures (such as manifesting, propellant tracking, and servicing activities, etc.) and to include access ports, through which the model can be accessed with additional subprograms or modifications. The model as presented in this document was not intended to be a complete formatting of all possible variations of all scenarios. It is expected and anticipated that the user will wish to make modifications.

Those unfamiliar with the SLAM language can gain an understanding of the operational processes by reading only the System Description (section 4). The Model Description (section 5) is a detailed walk through of the model and assumes a familiarity with both FORTRAN and SLAM, or a similar discrete event modeling language. The Program Description (section 6) is designed to familiarize the reader with the input requirements, output reports, and general usage of the model. The Appendices carry the greatest level of detailed, language dependent information.

4. SYSTEM DESCRIPTION

The transportation system originally modeled is the system expected to be in place in the mid-nineties. This transportation system assumes a three orbiter shuttle fleet operating from the Eastern Test Range (ETR) to deliver men and material to the space station and return. Delivery of payloads beyond the space station orbit assumes the use of other elements in the transportation system, an orbital maneuvering vehicle (OMV), and an orbital transfer vehicle (OTV) as upper stages. Some of the payloads delivered on-orbit require periodic on-orbit service over their lifetimes and are supported by the space-based transportation elements. Propellant for the space-based units is assumed to be delivered by the shuttle fleet and stored at or near the station.

4.1 BASE OPERATIONS

The system is driven by the transportation system's delivery requirements, defined on a yearly basis. Payloads are defined according to their physical characteristics (weight, length), destination, and service requirements. They are manifested into cargos for flight subject to the constraints forced by vehicle performance and space limits.

Each cargo is loaded based on its schedule and priority. Cargo delivered by the shuttle vehicle includes logistics, OMV and OTV propellants, and manifested payloads, prioritized in that order. The manifested payloads are specified as destined to be attached to the space station, for delivery in low Earth orbit, for delivery to geosynchronous orbit, or for a planetary flight. All delivery missions require the use of upper stages.

After the cargo is loaded onboard the shuttle, the vehicle processing continues through the launch pad. After pad processing is complete, the vehicle awaits clearance from the space station to launch. Launch clearance is controlled by the space station, subject to availability of the docking port and support for docking and offloading operations at the station. When clearance is received, the launch to the station occurs and docking operations begin. Offloading is performed sequentially subject to the processing requirements of each payload. The shuttle is not released until a set time interval after the last payload is removed, such that the time required for each space station delivery is dependent on both the type and number of payloads. On return from orbit, each shuttle is processed up to the point of receiving cargo. The readied shuttles then await the next mission and cargo assignment.

4.2 SPACE STATION OPERATIONS

ORIGINAL PAGE IS
OF POOR QUALITY

As the payloads are received at the station, they are sorted and processed according to their destination. The logistics, propellant, and attached payloads presently do not require the use of transportation elements based at the station; however, they do require support from the space station resources which are then not available to other payloads.

Payloads going to low Earth orbit (LEO), geosynchronous Earth orbit (GEO), and those payloads designated for planetary (PLAN) missions require the use of the OMV. In addition, both the GEO and PLAN payloads require the use of the OTV to be deployed to their final destination. These payloads then become the drivers of the space-based transportation elements. At the space station, the geosynchronous bound payloads are again manifested according to criteria based on weight, length, and number. This allows multiple payloads to be delivered on a single OTV flight.

The general disposition of payloads at the station is as follows:

Logistic Payloads

At this time the logistic payload is considered to be a full shuttle cargo and is not manifested with other payloads. No detail is included for station processing of these deliveries at this time, only an arbitrary time required to offload and attach to the station.

Payloads Attached To The Station

The only impacts of attached payloads on the transportation system are the requirements of delivery to the station and the offloading requirements at the station. An arbitrary time is assumed for this operation.

Propellant Payloads

Propellant deliveries are also considered to require a full cargo and are not manifested with other payloads. On delivery, no specific handling process is considered at this time, only a time interval is allowed for offloading of the propellants. The amount of propellants available at the station is tracked.

Low Earth Orbit Payloads

All payloads destined for low Earth orbit are considered to be offloaded, serviced at the station, mated with an OMV, and launched as rapidly as possible from the station. Once on orbit, the payloads are scheduled for servicing at intervals until their design life has expired.

Geosynchronous Orbit Payloads

All GEO and planetary payloads require the use of an orbital transfer vehicle for delivery. The GEO payloads are first offloaded, serviced, then multiple manifested for launch on the OTV. Present constraints are on the total number that can be manifested at any one time, length, and weight. Once delivered on orbit, the individual payloads can be scheduled for servicing as are the LEO payloads.

Planetary Payloads

The planetary payloads are considered to be single manifested, and each requires a single OTV for delivery. As delivery requirements frequently will exceed the OTV capacity, each planetary payload is assumed to carry its own kick stage to achieve interplanetary velocity.

The space-based transportation elements, the OMV and OTV, are serviced at the station prior to integration with the payloads. The OMV servicing includes the refueling operation. Once the payload has been delivered to its destination, the OMV returns for servicing and refueling. It is also used for launch and retrieval in support of OTV operations. In this scenario, servicing and launch of these elements require support of the Mobile Remote Manipulating System (MRMS) on the space station.

OTV servicing requires the use of the MRMS while the work is being performed. Refueling of the OTV takes place only after the payload has been integrated and both the MRMS and the OMV have been obtained for the launch operation. The OMV is used in proximity operations to maneuver the OTV with payload a safe distance from the station before the engines on the OTV are started in order to avoid contamination of the space station environment. After on-orbit delivery of the payloads, the process is reversed for retrieval of the OTV.

4.3 ORBITAL OPERATIONS

Orbital operations consist of the delivery of payloads to their orbital destinations and deployment. If the payload requires servicing on a periodic basis, it is scheduled at this time based on the service interval. These missions are called reservice operations and the appropriate time is allotted for this activity in addition to scheduling a propellant flight in support of the next service mission.

5. MODEL DESCRIPTION

The SLAM language was used to develop a combined network-discrete event model. The model consists of a data input file, a network model, and a FORTRAN event file described in the following sections and listed in the Appendices. A proprietary processor is required to execute the model. The data file STOPS.DAT (Appendix A) contains a list of the payloads that make up the mission model along with their attributes. It is this file that determines the demand placed on the transportation system. The network portion of the model is intended to illustrate the operations required to place payloads in orbit and service them, and is the major focus of the transportation model. The network code is broken into Base Operations, Space Station Operations, and Orbital Operations and is illustrated that way both in the STOPS.SLM file listing given in Appendix B and in the networks presented in figure 3. The networks consist of resources, queue nodes, and the activities that make up the present scenario. The discrete event file STOPS.FOR (Appendix C) contains the logic not easily handled by the network and allows the use of FORTRAN code in the model.

5.1 DATA FILE DESCRIPTION

The payloads for the mission are placed in a data file (STOPS.DAT in Appendix A). Each payload is defined in a free-formatted record in the data file. Seven fields, corresponding to a payload's first seven attributes, make up a data record. The first field contains the year the payload will be ready for launch. For example, a one in this field means that the payload will be available the first year of the simulation. Field two contains the Marshall Space Flight Center mission identification. This value is not necessary to run the simulation but is used to trace the payload as it progresses through the model. If this value is not known, enter a zero in this field. The payload weight (pounds) and length (feet) are contained in fields three and four, respectively. The fifth field contains the code for the payload type or destination: 1 = logistics, 2 = attached, 3 = OTV propellant, 4 = OMV propellant, 5 = LEO mission, 6 = GEO mission, and 7 = planetary mission. At the present time, fields 6 and 7 are not used. It is anticipated that they will later be used to define a reservicing schedule and a payload lifetime, respectively. These two fields should now contain a zero.

5.2 NETWORK MODEL

The network code is broken into Base Operations, Space Station Operations, and Orbital Operations and is illustrated that way both in the listing given in Appendix B (STOPS.SLM) and in the networks presented in figure 3. A very detailed description of the network is given in this section to allow the reader to walk through the model using figure 3 and the write up as a guide. Names of event nodes are italicized.

5.2.1 BASE OPERATIONS

The Base Operations module consists of the MANIFESTING NETWORK and the SHUTTLE NETWORK and is illustrated in figures 3a and 3b.

BASE OPERATIONS: MANIFESTING

The MANIFESTING NETWORK consists of both network and event file code. The event file code (Event 1 in STOPS.FOR) is designed to manifest those payloads carried in the input file (STOPS.DAT). The support payload code is designed to input those payloads which are either periodic (logistic payloads) or dependent on the number and type payloads in the input file (propellant payloads). In this program they are also considered as a complete cargo and are not manifested with the payloads from the input file.

The manifest network is read just once at the beginning of each year of the mission model. All payloads designated to be launched that year are considered in the manifest and grouped according to the criteria of total weight, length, and a number limit. (These are set in the network model using the global XX variables 18, 19, and 20, respectively.) The present values are 65,000 pounds, 60 feet, and 10 payloads. A tare weight penalty of 280 pounds per foot is allowed for each payload. Center-of-gravity location is not considered in this manifesting code. While the payloads are being manifested into cargos, the number of payloads requiring OTV delivery is tracked, and a propellant delivery to the station is scheduled prior to the cargo delivery. Once the payloads have been manifested into cargos, a launch date is scheduled for the cargo according to a uniform distribution, and this time is assigned to each payload in that specific cargo. The payloads are then placed into the network at the enter node in the proper sequence.

Support payloads are generated for the space station logistics at the *LOGS* node, and propellant deliveries are scheduled to meet the propellant requirements for the space-based transportation elements at the *POTV* and *POMV* nodes. Each of these payloads/cargos has its attributes assigned as part of the network code. The logistic cargos are manifested on a set interval by a

create node. Propellant flights are initialized in four different ways. First, an initial number of flights can be started in the propellant queues 1 and 2 to establish a propellant level at the station. Second, for the OTV propellant only, the payloads are previewed when the manifest is read, and propellant flights are scheduled to occur on the manifest prior to launch of those payloads requiring the use of an OTV. (Since payloads are manifested on the OTV, the number of payloads requiring a full propellant delivery varies. Therefore the number required to trigger a flight is arbitrarily chosen to be the expected average number manifested at the space station set in XX(15).) Third, the scheduling of a service mission to GEO also triggers the scheduling of a propellant flight to support this mission prior to its occurrence. And fourth, the requirement for a propellant flight is controlled by the fuel level at the station and is scheduled from event files 5 and 6 when the fuel storage falls below a preset level. All support payloads enter the network at queue 3 (*INPT*) and are prioritized according to logistics first, then propellant flights, and the manifest payloads last. These payloads are then grouped into cargos at the batch node *BATS* and proceed to the manifest queue (*MANQ*) to match the schedule (*SCHQ*) and then await assignment of a shuttle.

BASE OPERATIONS: SHUTTLE NETWORK

In the SHUTTLE NETWORK the cargo must first be matched with an entity from *SCHQ* before it can proceed. This is a means by which a specific flight rate can be set by using the interval between creations at *SCDQ*. Generally the model is allowed to run unconstrained by this controlling technique, by setting the creation interval at *SCDQ* to a higher value than the maximum flight rate anticipated. The cargo entity then waits for the next available shuttle at *AWS*. Activity 9 then allows 96 hours for payload installation. From there, the entity moves to the launch pad *LAUN* where an additional 264 hours is required for further processing. When the processing at the pad is completed, the vehicle must wait for clearance (CLR1) from the space station before launching. This assumes that only one shuttle is allowed to offload at the station at a time. Activity 11 allows 2 hours time for ascent to the station. An additional 1.5 hours is assumed for docking operations at *DOCK*. At this point the entities are duplicated and split at the *SPL* node. One entity, representing the cargo, goes to *UNBS* in the STATION NETWORK, while the second, representing the shuttle, proceeds to *NEXT* to wait for release based on the detect node *ORB*. This node is used to indicate when all payloads have been removed from the shuttle bay at the station. On release, an arbitrary delay of 24 hours is assumed for return preparations prior to the shuttle leaving the space station. At that time the

clearance CLR1 is freed so that another launch can take place. The shuttle then deorbits and returns to a landing in 1 hour. The vehicle is then serviced at *SERV* using one of the two service bays. On completing service the shuttle is freed at *FSHU* for assignment to a new cargo.

5.2.2 SPACE STATION OPERATIONS

SPACE STATION OPERATIONS: STATION NETWORK

Cargos are received at the station through the unbatch node *UNBS*. Each payload is then redefined individually with all of its original attributes. Each payload is removed, one at a time (single service), taking 24 hours each. The payload must then wait at *AWRM* for the station's Mobile Remote Manipulating System (MRMS) to move it to a new position on the station. In a sorting process at *SEL*, each payload is then moved to its destination on the station based on its attribute 5 value. No delay time is considered for the sorting process.

The logistics payloads are considered in *LOG* where after a 24-hour activity period, the MRMS is released. No further action is considered for the logistics modules.

Payloads that are to be attached to the space station and require no additional support of the transportation system are moved to *ATI*. The MRMS is freed after an 8-hour delay for installation of the payload.

Propellants for the OTV and OMV are processed through the *OTVP* and *OMVP* nodes, respectively. Event files 5 and 6 are used to track the level of propellants stored at the station. When an arrival occurs, the propellant level is increased by the delivered weight stored in attribute 3. The propellant level is then checked, and if it is below a preset level, an additional propellant flight is scheduled before returning to the network. A delay time of 48 hours is assumed for offloading and securing the propellant before the MRMS is released.

Payloads destined for low Earth orbit, geostationary orbit, and interplanetary flight place demands directly on the transportation elements based at the station. These then are treated in greater detail at the *LEO*, *GEO*, and *PLAN* nodes, respectively. It is assumed that all LEO payloads can be delivered by the OMV and that only the GEO and PLAN payloads will require the use of an OTV for delivery. Even with the OTV, the delta V capability is not always sufficient for planetary launch. In these cases it is assumed that a kick stage is included in the payload to achieve the necessary velocity.

The payloads going to *LEO* are considered to be serviced in 24 hours before releasing the MRMS. This entity is then sent to *OMV* in the TRANSPORTATION NETWORK for integration with the OMV and launch operations.

Unlike LEO payloads, GEO payloads are multi-manifested. After a 48 -hour servicing period, the MRMS is released for each payload. Event 7 is used to record the arrival of each payload and then to manifest it at the station for launch on the OTV according to the specifications of weight, length, and overall number. These are presently set at 20,000 pounds, 40 feet, and 4 payloads, respectively. (The global XX variables 21, 22, and 23 are used. Changes to XX(21) will also require changes to propellant requirements in XX(24) and XX(25) to reflect the characteristics of the new OTV.) Once a cargo is manifested, the entities for each payload in the cargo, along with their attributes, are returned to the network and placed in *Q7*. They are then batched into cargos at *BATO* according to attribute 10 which was set to the same value in event 7 for each payload in a cargo. All attributes are carried. The entity representing the cargo is then sent to the *OTV* node in the TRANSPORTATION NETWORK for integration to the OTV and launch operations.

The payloads destined for interplanetary delivery are processed through the *PLAN* node. A service period of 48 hours is also considered prior to releasing the MRMS. The entity is then sent to *OTV* in the TRANSPORTATION NETWORK for integration and launch operations. Because of the high delta V requirements, all planetary payloads are considered to be singly manifested.

SPACE STATION OPERATIONS: TRANSPORTATION NETWORK

As a transportation node, the space station has to support several elements of the transportation system by providing service, integration of the payloads with the transfer vehicles, and launch and retrieval operations. The TRANSPORTATION NETWORK is divided in this same manner and is illustrated in figure 3d.

Between flights the transfer vehicles must be maintained and serviced at the station. OMV service begins when an entity is sent to the *OMVS* node. Three hours are allowed for inspection and planning operations prior to fueling. Fueling takes place when the entity is passed to Event 6. If there is insufficient fuel available, the entity is held until a sufficient increase is detected at *DIOMV*. The entity is then released and re-enters Event 6. At present, the amount of fuel removed is a constant 2500 pounds for each service. This can be based on payload weight and destination. The time required for fueling is set at 6 hours. The OMV is then freed for use either to deliver a payload in low Earth orbit or to aid in launching or retrieving an OTV.

OTV service begins at the *OTVS* node. The purge and drain operation is considered to take place away from the station. The MRMS is then used to secure the OTV while inspection, planning, and removal and replacement of space replaceable units (SRU) take place. The MRMS and OTV are then freed.

The demand on the space-based transportation elements is initiated in the integration networks by having an entity representing either a payload for delivery to low Earth orbit or a cargo for geosynchronous orbit sent to the *OMV* or *OTV* node, respectively.

The OMV integration activities begin with the await node *A2*, based on allocation rule 2. (See STOPS.FOR, Subroutine ALLOC.) This requires that both an MRMS and OMV be available before proceeding. After the MRMS is used to integrate the payload with the OMV, it is released. The loaded OMV is then launched at *OMVF*. The flight out takes 4 hours, and the payload is deployed. Event 8 is used to schedule a service mission for each payload based on year multiples as defined by the user in global variable XX(10), set in the network. In this case the service time multiple for the missions is defined as one year. Actual deployment time is considered to be 1 hour if it is an initial deployment (activity 56) and 24 hours if it is determined to be a service visit to a satellite (activity 55, where attribute 2 equals the code 9999). In either case the entity returns to the OMVR node, constituting a 4-hour return flight. The OMV then returns for servicing at OMVS.

The OTV integration activities begin with the await node *A1*, based on allocation rule1 in the FORTRAN code. This requires that both the MRMS and the OTV be available before proceeding. Payload integration is considered to require 5.25 hours, followed by 6 hours for fueling operations. Event 5 is used to control fueling of the loaded OTV. Fuel requirements are based on the total cargo weight carried in attribute 3. If there is insufficient fuel available, the MRMS is released and the entity is held until the fuel level has increased enough to trigger a release from the detect node *DIOTV*. Then the MRMS must again be obtained before returning to Event 5 for fueling. Once the OTV is fueled, the MRMS is freed from the fueling operation and the vehicle begins proximity operations at the *PRXOP* node.

The OTV flight operations are considered a part of the TRANSPORTATION NETWORK. Before the OTV fires its engines, it is moved away from the station by the OMV. The OMV is then freed after a fuel penalty is recorded in Event 6 to account for the proximity operations. No time is allotted since it is assumed this time is accounted for during normal servicing. After a delivery to GEO in 27.4 hours, the actual delivery operation can take one of three paths. If it is a planetary payload (ATTRIB(5)=7), then activity 67 is taken, and a 1-hour deployment is assumed. If the cargo consists of manifested payloads, activity 64 is taken and a 1-hour deployment is assumed. Then the entity is sent to the unbatch node *UNBO*, where the payloads are again separated so that their individual attributes are identifiable. Here they can schedule service missions. If it is a service mission (ATTRIB(2)=8888), then activity 68 is taken, and a

48-hour service time is assumed. After a return flight of 27.4 hours, the OTV stands off from the space station and awaits the use of the OMV. The OMV rendezvous with the OTV, mates, and returns it to a docking port on the station for service (*OTVS*) prior to its next flight.

5.2.3 ORBITAL OPERATIONS

At this time, orbital operations consist of checking for and scheduling service operations in both LEO and GEO. A service mission for LEO is scheduled from Event file 9 by entering an entity in *Q8*. The code for a LEO service mission (ATTRIB(2)=9999) is then set in the assign node, and the entity is sent to the *OMV* node for integration and flight.

Payloads deployed in GEO are separated at the *UNBO* node and deployed sequentially. If service is desired for the GEO payloads (a reservice interval is set in the network STOPS.SLM using XX(11)), the scheduling is done in Event 10. The service missions for GEO are initiated from Event file 11 and enter through *Q10*. The code for a GEO service mission (ATTRIB(2)=8888) is then set in the assign node, and the entity is sent to the *OTV* node for integration and flight.

5.3 FORTRAN EVENT FILE:

SLAM, a Simulation Language for Alternative Modeling, is an advanced FORTRAN-based language that provides network modeling and subprograms that support both discrete event and continuous model developments. A discrete event model of a system is constructed by describing changes that occur in the system at discrete points in time. The point in time where the state of the system may change is referred to as an "event time", and the corresponding FORTRAN code for processing the changes in state is called an "event". This model employs twelve discrete events in the file STOPS.FOR (Appendix C).

Event One, the shuttle payload manifest code, is read at the beginning of each year of the mission model. All payloads in the input file (STOPS.DAT) designated to be launched during that year are assembled into cargos. Shuttle cargo constraints are presently set at a weight of 65,000 pounds, a length of 60 feet, and a maximum of 10 payloads per shuttle mission. A tare weight penalty of 280 pounds per foot is assessed for each payload. The cargos are then assigned a launch time according to a uniform distribution; that is, the cargo launch times are spread out evenly over the year. Each payload in a cargo is given the same launch time and placed on the event calendar by the SLAM subroutine SCHDL, thereby calling Event Three at the appropriate time. During this manifesting process a count of the planetary and GEO payloads is maintained

in order to assure that an OTV propellant delivery to the space station is scheduled prior to the cargo delivery to meet the fuel requirements of the shuttle mission. The user can assign the number of planetary and GEO payloads that are required before scheduling an OTV propellant flight using the SLAM global variables XX(14) and XX(15), respectively. These are set in the network file STOPS.SLM. The variables are currently set at one planetary and three GEO payloads. The resulting shuttle propellant missions are included in the total cargos for the year when assigning launch times and placed on the event calendar by the use of SLAM subroutine SCHDL. In this case Event Two is placed on the event calendar.

Event Two inserts an OTV propellant delivery mission into the network by placing an entity into file 1 (the POTV node). This event is called by either Event One or Event Ten having scheduled it to occur on the event calendar. OTV utilization requirements at the space station necessitated an OTV fuel delivery prior to either a prescribed number of planetary or GEO payloads (as previously described in Event One) or prior to a GEO service mission (as will be described in Event Ten).

Event Three is called by having Event One place it on the event calendar. Each payload in a manifested cargo was given the same launch time, and this event places these payload entities in the network at the ENTER node.

The SLAM network calls **Event Four** to record shuttle launch time. This event is called after the payload entities with the same launch time have been collected into a shuttle cargo. The attributes printed out in this event are those of the batched cargo.

The OTV propellant farm is described in **Event Five**. This event records the level of the OTV propellant at the space station. Event Five is called from the network on two occasions: delivery of OTV propellant to the station and the OTV refueling operation. If OTV propellant arrives at the station, the current level of fuel is increased by the propellant delivery weight. The OTV refueling operation results in a draw down on the level of fuel. GEO, GEO service, and planetary missions require the use of the OTV. The amount of fuel required for a GEO mission is calculated based on a factor of the payload weight and an amount of fuel required for the OTV itself, presently set at 53,935 pounds. The weight of a GEO service module is stored in the SLAM global variable XX(13) and can be changed by the user in the SLAM network. The variable currently has a value of 18,000 pounds. If the OTV is fueled for a planetary mission, the calculated fuel requirement is overridden and 85,740 pounds of OTV propellant will be withdrawn from the propellant farm. Prior to exit from Event Five the present OTV fuel level is observed. To assure sufficient propellant to meet subsequent mission requirements if the fuel level is less than 200,000 pounds (XX(17)), an

OTV propellant flight is immediately scheduled by placing an entity into file 1.

Similarly, **Event Six** represents the OMV propellant farm. This event is called from the network on three occasions: delivery of OMV propellant to the space station and OMV refueling operations for either proximity operations or LEO missions. In the case of an OMV propellant delivery, the amount of propellant is added to the existing level. If the OMV is to be fueled for a proximity operation, 400 pounds of fuel are withdrawn from the propellant farm. At present a LEO mission requires a withdrawal of a fixed amount of propellant (2,500 pounds) for each delivery mission. Before returning to the network if the fuel storage level is below 50,000 pounds (XX(16)), an OMV propellant mission is entered into the network by placing an entity in file 2.

Event Seven is used to record the arrival of each GEO payload and manifest it at the station for launch on the OTV. OTV cargo constraints are presently set at a weight of 20,000 pounds, a length of 40 feet, and a maximum of four payloads. Each payload in a manifested cargo has attribute 10 set to the value of the number of payloads constituting the cargo. The entities for each payload in the cargo, along with their attributes, are returned to the network by placing them in file 7.

Event Eight places Event Nine, a service mission for LEO, on the event calendar by using the SLAM subroutine SCHDL. SLAM global variable XX(10), presently set at 1, is the service time multiple for OMV/LEO payloads. This value may be changed by the user in the network.

Event Nine schedules service operations in LEO by placing an entity in file 8. **Event Eight** is used to place Event Nine on the event calendar. Service missions for GEO are handled in a similar manner by Events Ten and Eleven. SLAM global variable XX(11), presently set at 9, is the service time multiple for OTV/GEO payloads. **Event Ten** places a call to Event Eleven on the event calendar by the use of the SLAM subroutine SCHDL. Also, in anticipation of an OTV propellant withdrawal at the space station for the service operation, an OTV propellant flight is scheduled on the event calendar 30 days (global variable XX(26)) prior to the service mission by placing a call to Event Two on the event calendar.

Event Eleven is called by having Event Ten place it on the event calendar. Event Eleven then initiates a service operation to GEO by placing an entity in file 10. **Event Twelve** is called from the network at the end of each year of the mission model. This event tabulates yearly values prescribed by the user to aid in interpreting the results of the simulation.

In addition to the twelve events described above, STOPS.FOR contains subroutines ALLOC, INTLC, and OTPUT. Subroutine ALLOC is called by SLAM when an entity arrives at an AWAIT node whose resource is specified as ALLOC

or when the file associated with that AWAIT node is polled as the result of a newly available or freed resource. There are two such occurrences of the AWAIT node in the network: one for OTV activities and the other for OMV activities. The AWAIT node for OTV activities, whose resource is specified as ALLOC(1), stores entities waiting for the MRMS and the OTV. When one unit of each resource is available, they are seized, and the entity proceeds from the AWAIT node. The AWAIT node for OMV activities, whose resource is specified as ALLOC(2), stores entities waiting for the MRMS and OMV. Similarly, when both necessary resources are available, one unit of each resource is seized, and the entity continues through the network.

The user-written subroutines INTLC and OTPUT are commonly used in discrete event simulations. **Subroutine INTLC** is called by SLAM before each simulation run. It is used in this model to display the description and value of each global variable for the current run. **Subroutine OTPUT** is called by the system at the end of the simulation. It prints headers and the yearly tabulated values collected in Event Twelve as previously described. (See example output, figure 5.)

If a more detailed description of this file is needed, the reader may wish to refer to the comments in the FORTRAN code (Appendix C). Also available are variable traces and diagnostic messages in the form of write statements. These have been commented out to reduce the amount of output, but could be made active by the user to aid in understanding the logic flow and tracking errors.

6. PROGRAM DESCRIPTION

6.1 USAGE

The user is assumed to be familiar with the standard SLAM control cards used to set run conditions and termination requirements. Two other assumptions are made concerning input: one, that the user will use an editor to modify the activity durations and resource levels in the network model, and two, that most of the parameters that the user would need to change in the FORTRAN event file code will be included in the network model as global variables in INTLC. Thus, unless modifications are made to the basic program, the user would normally be able to control input to the program by simply modifying values in the network model. Also note that this illustration is for a model set up for a deterministic output only. This is to allow for a parametric approach to determine a range of possible solutions. A stochastic approach to the problem requires the replacement of the appropriate parameters by the desired or given distribution for that activity and the corresponding changes in the control cards.

The program can be run on either a mainframe or personal computer. The example given below was run on an IBM AT, with 512 kilobytes of memory and a 20 megabyte hard disk. Total run times were approximately 7.5 minutes but will vary slightly depending on the output requested. These times are comparable to mainframe turnaround times. As presently set up for the AT, the program root name is the same for all files with the extender being used to identify the three file types, i.e., DAT, SLM, and FOR. (When file names are changed, the file name opened within the FORTRAN file should be changed to the new file name.) The program is run by having all three files resident on the computer and by specifying the desired parameter values and run conditions in the network file STOPS.SLM. The SLAM processor looks for each file as needed, and generates the result in a summary report. Access to the results is through a menu driven prompt. The output can be either printed, viewed, or stored on another file.

6.2 EXAMPLE

An example program is included with the required data, network, and event files shown in Appendices A, B, and C, respectively. This program was run for a three-shuttle fleet using the resources and processing times shown in the network model in Appendix B. The model was driven by the input file illustrated

in Appendix A for a simulated 10-year period. The file contains 392 payloads to be manifested but does not contain the support payloads which are generated by the model. Payload delivery rate increased each year of the mission model. Two output files were generated, the standard SLAM summary report shown in figure 4 and a user-generated report shown in figure 5. Reference to figure 3, the network model diagram, should aid in the interpretation of the results.

Figure 4, the summary report, shows the 10-year statistical summary for files, regular activities, service activities, and resources. The file statistics illustrate the delays that occur in the operations when a vehicle, cargo, payload, etc. must wait for service or resources before it can proceed. The results indicate a 2.5-hour delay for the shuttle to receive servicing (SERV queue, file 5) but an average of over 29 hours for payloads to be offloaded at the space station (SSTA queue, file 6). The delays experienced at SCHQ (file 11) can be ignored in this case as they are an artifact of the very high rate set to assure that this control factor would not limit the flight rate. The delay of over 300 hours at AWS (file 12) and the queue length of 15 represent the delay of the cargos having to wait for a shuttle assignment. There are also long delays in the station activities waiting for the MRMS (AWRM, file 14) and in processing the space-based elements due to the allocate routines A1 and A2 (files 18 and 17, respectively). Although long delays are seen in a number of operations, these results do not indicate if the conditions existed over the whole time period or only in the latter years of the mission model when the delivery requirements were higher. These results should indicate which operations need to come under closer examination, and this can be done by creating intermediate summary results for each year of the model and observing the results. This option is available in the SLAM programming but is not illustrated here. Another alternative is the creation of a user-written routine to record the yearly values, and this will be discussed later in figure 5.

Regular activities are those not emanating from a queue or an await node. These statistics can be used to determine the maximum and current utilization of certain tasks (activities) and the total number of times that these tasks were performed. From this result one can quickly determine that for this mission model and operating scenario, there were 295 launches to the space station (activity index 11) delivering 579 payloads (activity index 21). These consisted of 78 logistic modules, 125 payloads attached to the station, 110 propellant deliveries for the OTV and 10 for the OMV, 25 payloads for low Earth orbit, 218 for geosynchronous orbit, and 10 payloads for planetary delivery (activity indices 24 to 30). From the station, all 25 LEO payloads were deployed (activity index 56) which resulted in 134 complete OMV flights for deployment and service (activity index 57). These payloads were reserviced on a fixed

1-year interval. A total of 95 OTV missions from the station were completed during this 10-year period (activity index 71). Eighty of these were manifested cargos delivered to GEO (212 payloads-activity index 75), 10 were planetary launches, and 5 were for service in GEO on a 9-year service interval (activity indices 66,67, and 68, respectively). From these results the level of delivery that the system achieved can be observed. Parametric studies varying the task time or resource level will illustrate the effects on delivery rate.

The service activity statistics provide an indication of the utilization and total number of users for each service. For example, the initial service for the vehicles indicates that 293 have been processed, 2 are currently being processed, and the average utilization is slightly over 1 service bay, or 53% for each bay.

The resource statistics provide utilization rates for the resources. For example, at the end of the tenth year all three shuttles are being used, and the average has been for two and a half shuttles to be in use at any one time, or an 85% utilization rate for each orbiter.

Figure 5 presents an example of a typical user-generated output routine which summarizes the yearly results for selected parameters. These outputs consist of an echo of the input parameters, a set of warning messages which will appear whenever this routine is invoked, and the user-written code which is broken into the Base, Space Station, and Orbital Operations, and Propellant Summaries. The parameters used are identified with the activity index number as illustrated in figure 3, the network model diagram.

The echo of the parameters provides the user with a record of the parameters used for each run. This output, combined with the warning statements, allows the user to modify the input values used to achieve a desired level of activity. The warnings appear for several different reasons. Presently, warnings appear from the manifesting routines whenever the weight or length constraints are exceeded. The parameters are displayed to identify the particular payload that triggered the warning statement. The program will continue to run, but the user should look at the input parameters that are being used and make either the limits or the payload parameters consistent. Warnings also appear when the OTV is prepared for launch, but fueling operations would drop the propellant level below zero if the vehicle is fueled. A delay then occurs until sufficient propellant is delivered to allow for the fueling operation. The time of occurrence is also displayed. Although some warnings are to be expected, an excessive number of warnings of this type would indicate the need to modify the delivery parameters to achieve fewer delays.

The Base Operations output summarizes the yearly launch rates of the manifested and the support cargos (activity 7), the number of launches (activity

11), and the total number of payloads that were manifested for launch (activity 6). The number of cargos should almost match the number of launches if the flight rate is unconstrained, and generally it does until the tenth year, when the launch rate can no longer match the number of cargos that have been manifested. (Compare activities 11 and 7.)

The Space Station Operations output summarizes the yearly deliveries to the station. For this example, the support deliveries for logistics and OTV propellant have not matched the needed delivery rate (compare activity 24 with 4, and 26 with 2) in the tenth year.

The Orbital Transportation Operations output summarizes the yearly delivery on orbit of those payloads launched from the station. Also shown are the year-end levels for OTV and OMV propellant. A comparison of activities 56 and 55 illustrate the large number of service missions created by the requirement for a 1-year service interval on the payloads placed in low Earth orbit. The 9-year interval for GEO payloads only begins to require additional OTV missions in the tenth year (activity 68). But each of these missions also will have scheduled a propellant delivery prior to the service mission, adding to the manifest requirements in this tenth year and possibly causing the demand to exceed the shuttle fleet capability. The propellant levels shown indicate that the storage levels set for both systems are approximately the appropriate size.

The propellant summaries display both the minimum and maximum propellant levels for both the OMV and the OTV on a yearly basis. This output is valuable both in adjusting the parameters that control propellant delivery and in sizing the on-orbit tankage requirements for these propellants. The parameters that control propellant delivery are those that determine the number of payloads required to schedule a propellant flight, those that control lead time to support service missions, and the reorder point propellant level. No specific space station tankage is set in the program at this time. For the scenario depicted, it appears that storage facilities on the order of 200,000 and 300,000 pounds would be required for the OMV and the OTV propellants, respectively.

By comparing the results in figures 4 and 5 and by using other optional reporting features the user should be able to observe the transportation system's response to the mode of operation, resource limitations, and task time requirements. The observations of the example program would indicate that a larger shuttle fleet or shorter service times would be needed by the tenth year in order to support this mission model. Alternately, the user might wish to examine the effects of eliminating service to GEO payloads, as this placed a heavy demand on the delivery system. These and other alternatives can be evaluated using the model.

7. CONCLUDING REMARKS

This paper has presented a description of a computer program which allows assessment of the operational support requirements of space transportation systems functioning in both a ground-and space-based environment. The scenario depicted in the paper provides for the delivery of payloads from Earth to a space station and beyond using upper stages based at the station. Model results are scenario dependent and rely on the input definitions of delivery requirements, task times, and available resources. Although written for a specific scenario, the model can be modified with relative ease to study similar transportation systems. An example of program output is included in terms of flight rate capabilities, resource requirements, and facility utilization. The example illustrates how the program can be used to identify operational tasks and resources which may limit the capability of a system to fulfill its mission, and how to modify the program to test alternate solutions.

8. REFERENCES

1. The Report of the National Commission on Space: Pioneering The Space Frontier. Bantam Books, N.Y., New York, 1986.
2. Schlaheck, R. A.; and Byers, J. K., "Simulating the Operations of the Reusable Shuttle Space Vehicle." Proceedings of the 1971 Summer Computer Simulation Conference, pp. 152-192, July 1971.
3. Wilson, James R.; Vaughn, David K.; Naylor, Edward; and Voss, Robert G., "Analysis of Space Shuttle Ground Operations." Simulation, Vol. 38, No. 6, pp. 187-203, June 1982.
4. Morris, W. D.; Talay, T. A.; and Eide, D. G., "Operations Simulation for the Design of a Future Space Transportation System." Presented at the AIAA 21st Aerospace Sciences Meeting, paper no. 83-0140, January 1983.
5. Morris, W. Douglas; Rehder, John J.; Talay, T. A.; and White, Nancy H., "Impact of Transportation Operations on Space Station Traffic Levels." Presented at the Rendezvous and Proximity Operations Workshop, JSC, February 1985.
6. Ingemen, Donald, "Simulation Models: Analysis and Research Tools." Proceedings of the 1978 Annual Reliability and Maintainability Symposium, pp. 184-189, 1978.
7. Pritsker, A.A.B., Introduction to Simulation and SLAM. Systems Publishing Corp. and Halsted Press, N.Y. 1986.

FIGURES

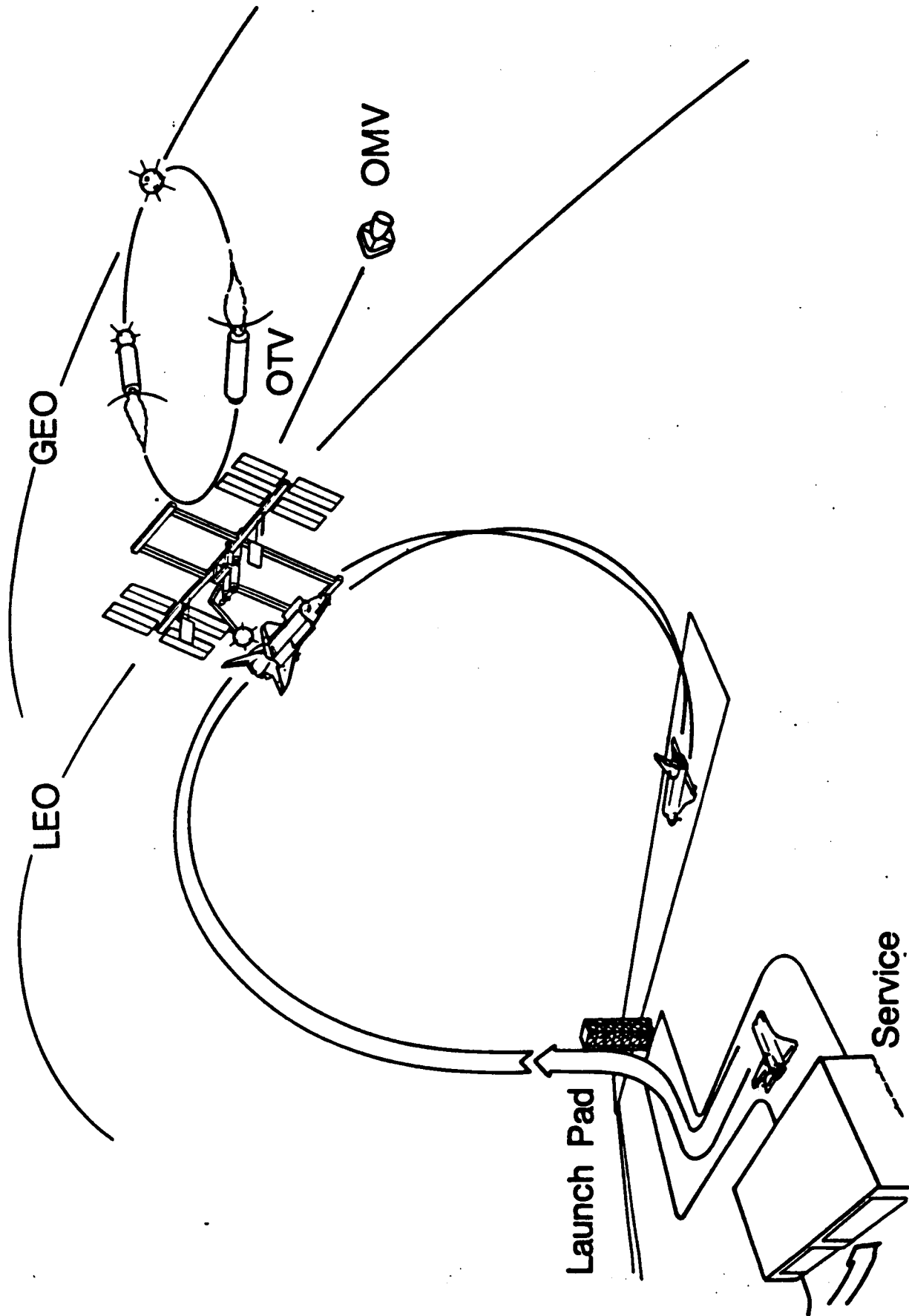

Figure 1. Transportation System Operating Scenario.

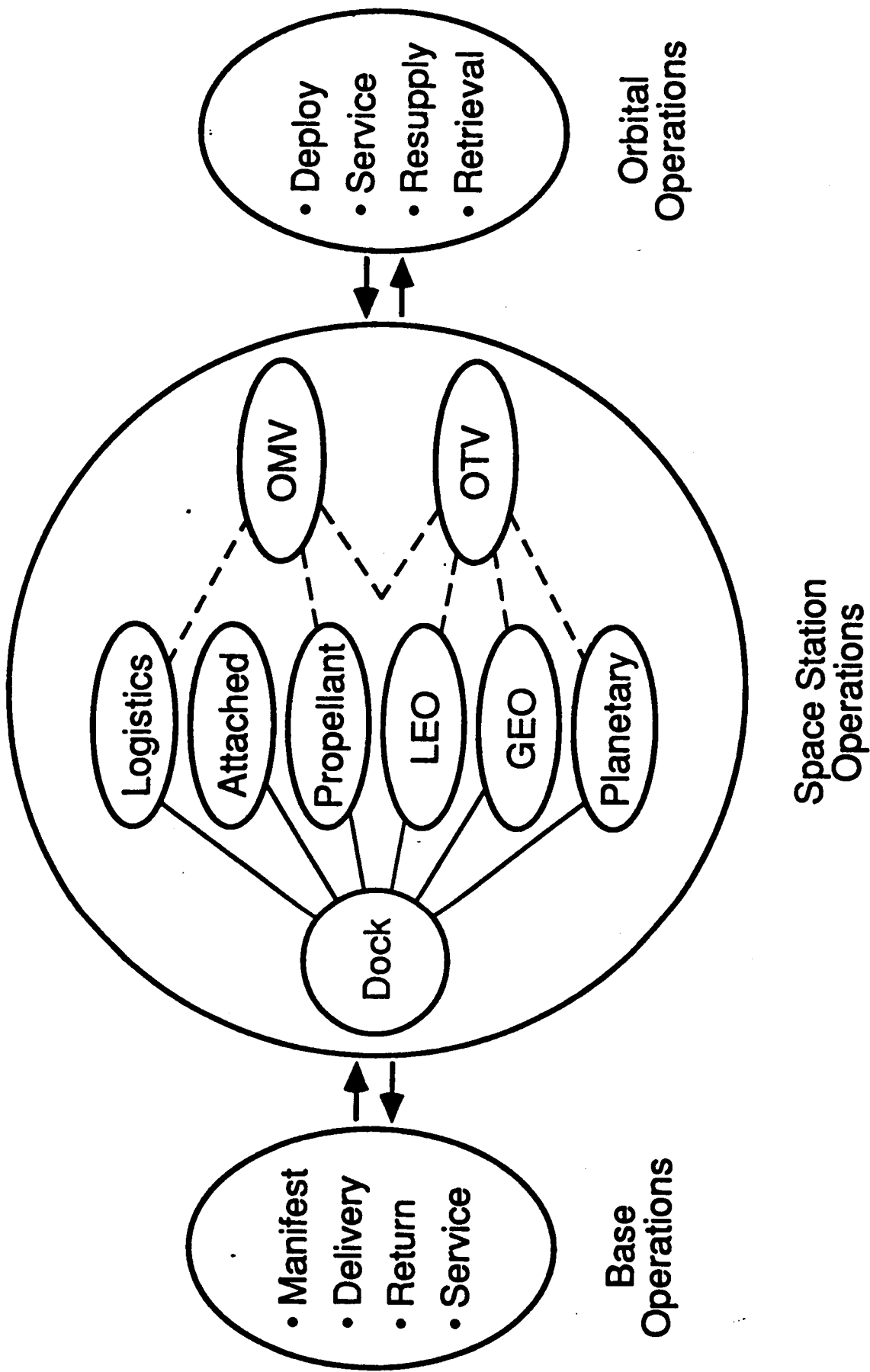
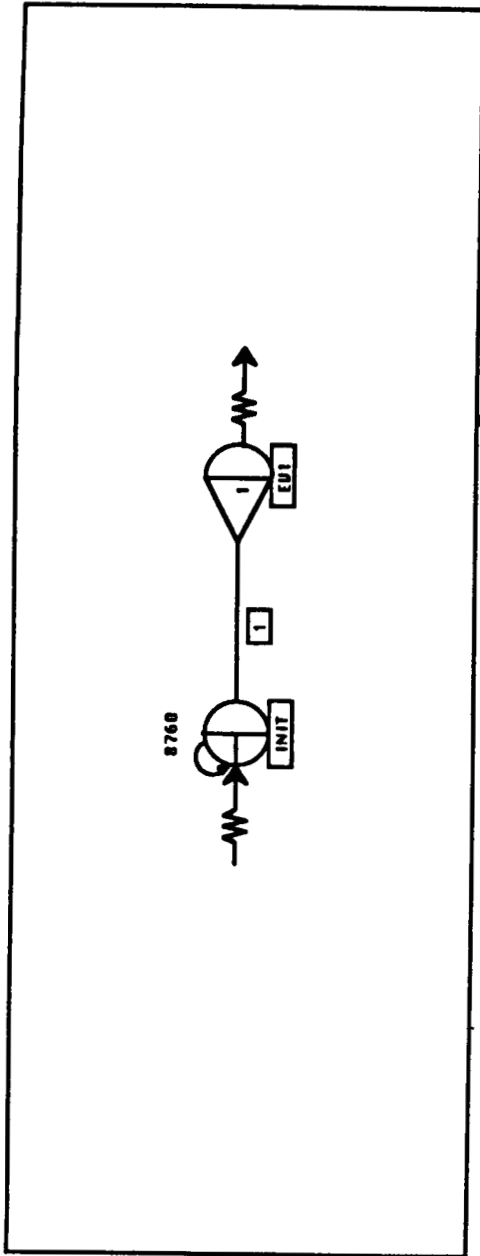

Figure 2. Schematic of the Space Transportation System Operations Model.

READ & MANIFEST PAYLOADS



RESOURCE BLOCK

SHUT(3)	12	
CLR1(1)	13	
MIRMS(1)	14	17 18
OMD(1)	15	17
OTU(1)	11	18

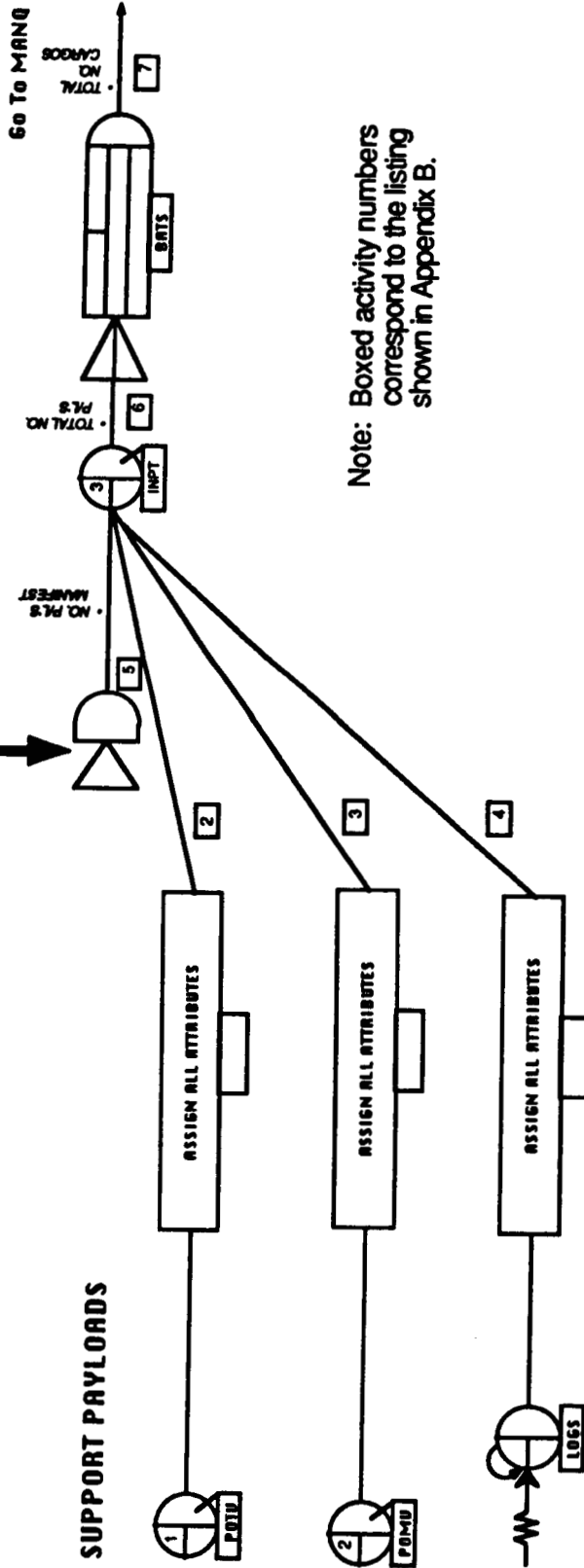

Note: Boxed activity numbers correspond to the listing shown in Appendix B.

(a) Base Operations: Manifest Network.

Figure 3. Network Model.

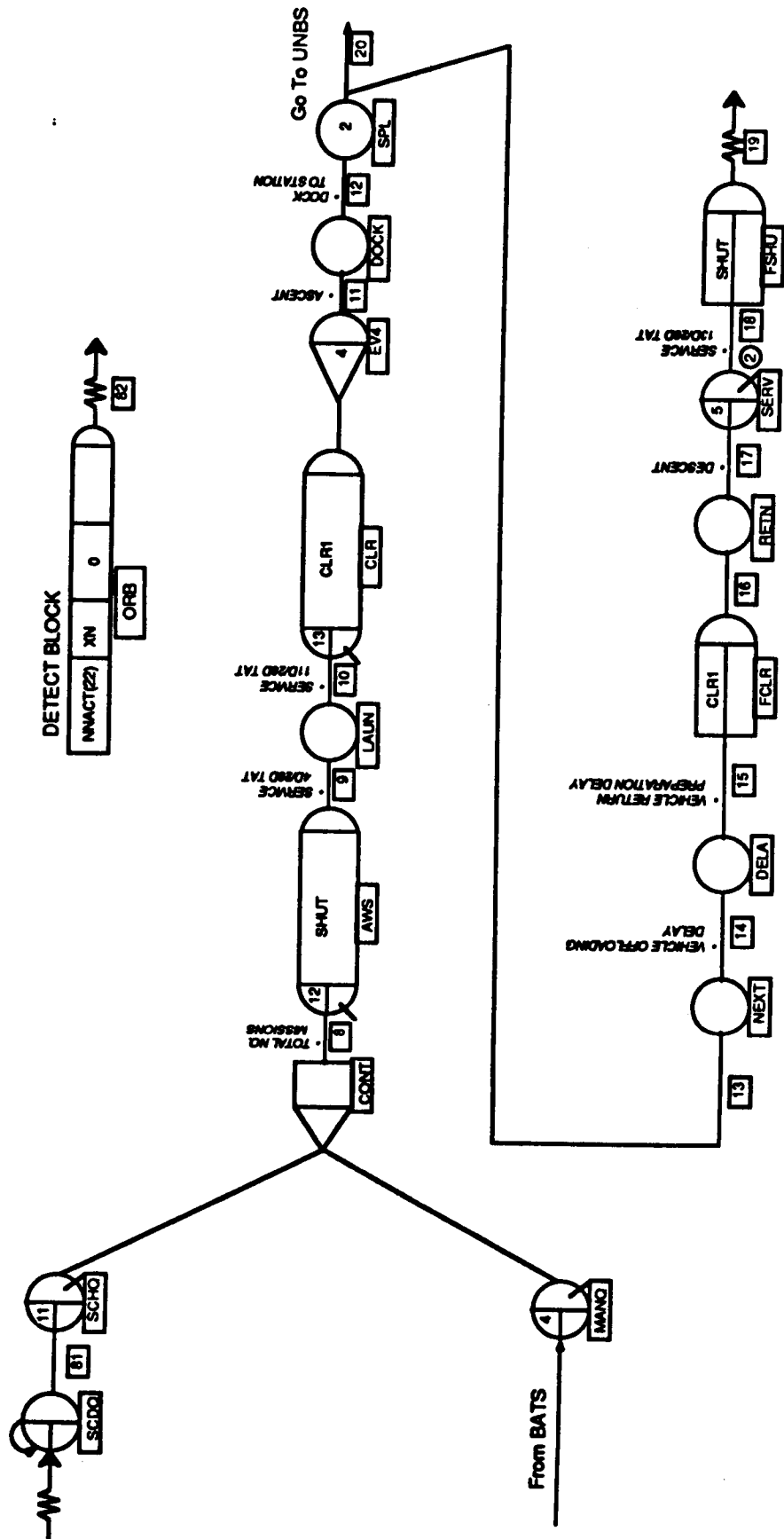

(b) Base Operations: Shuttle Network

Figure 3. Network Model.

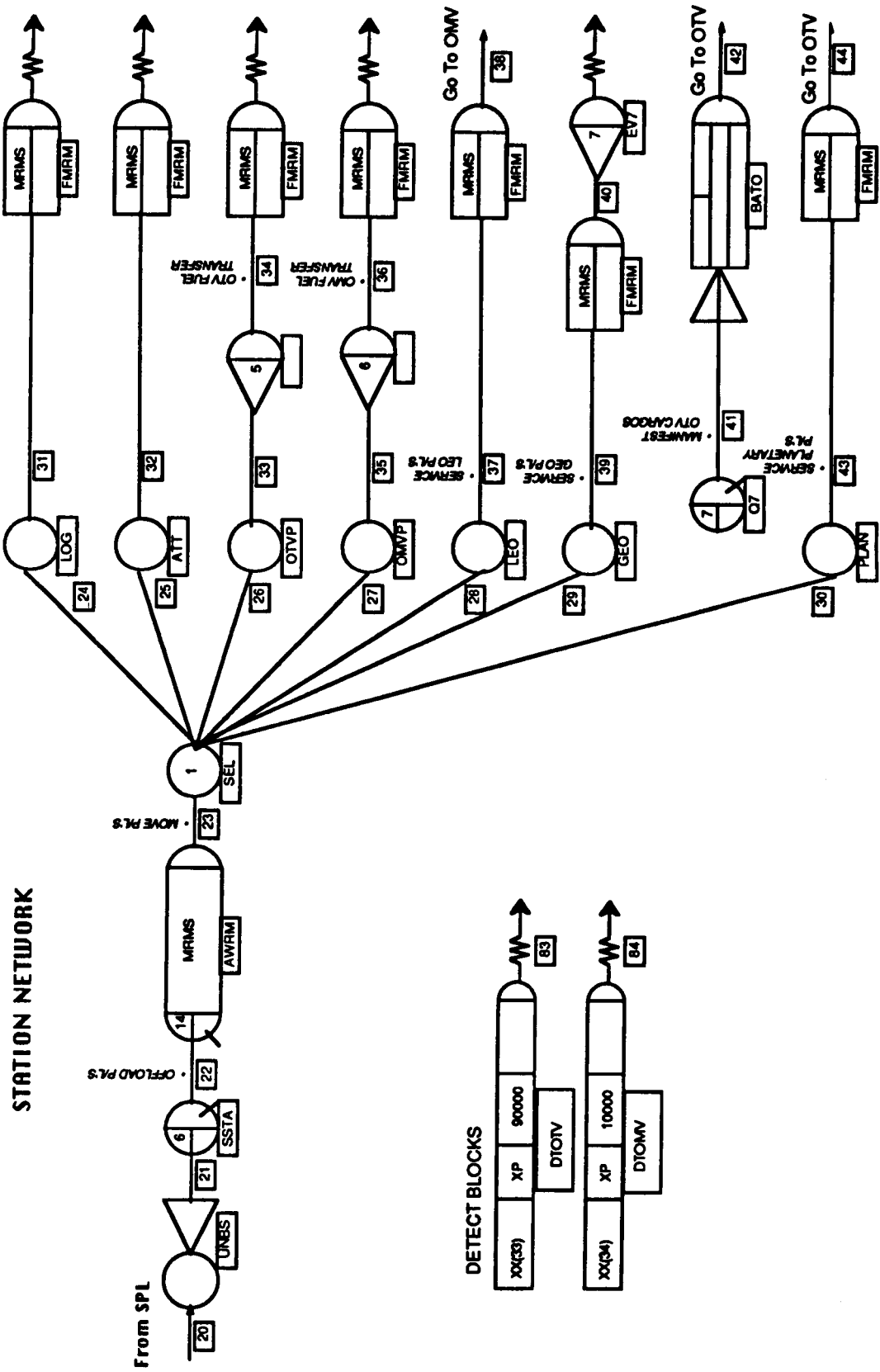

(c) Space Station Operations: Station Network

Figure 3. Network Model.

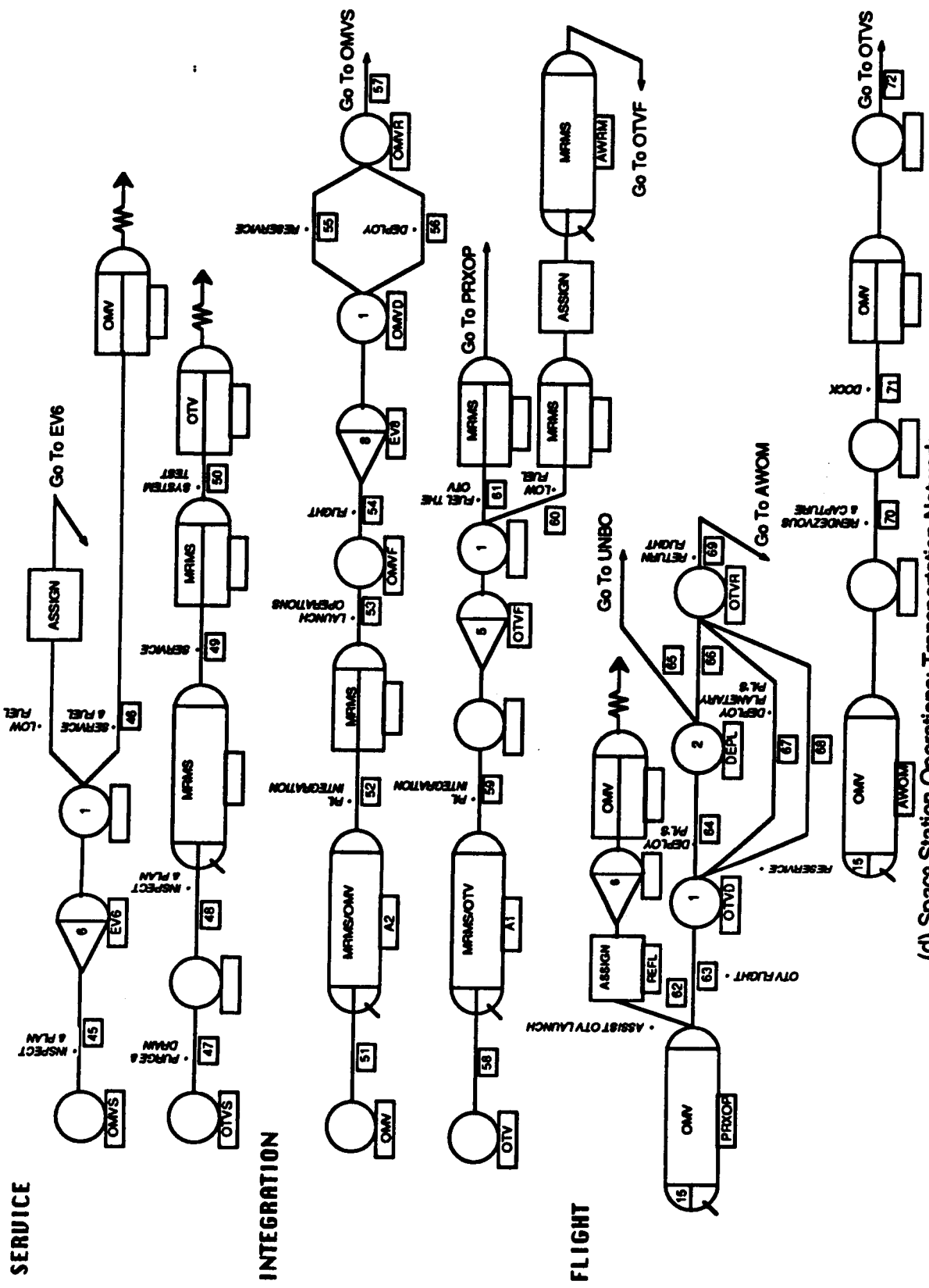

(d) Space Station Operations: Transportation Network.

Figure 3. Network Model.

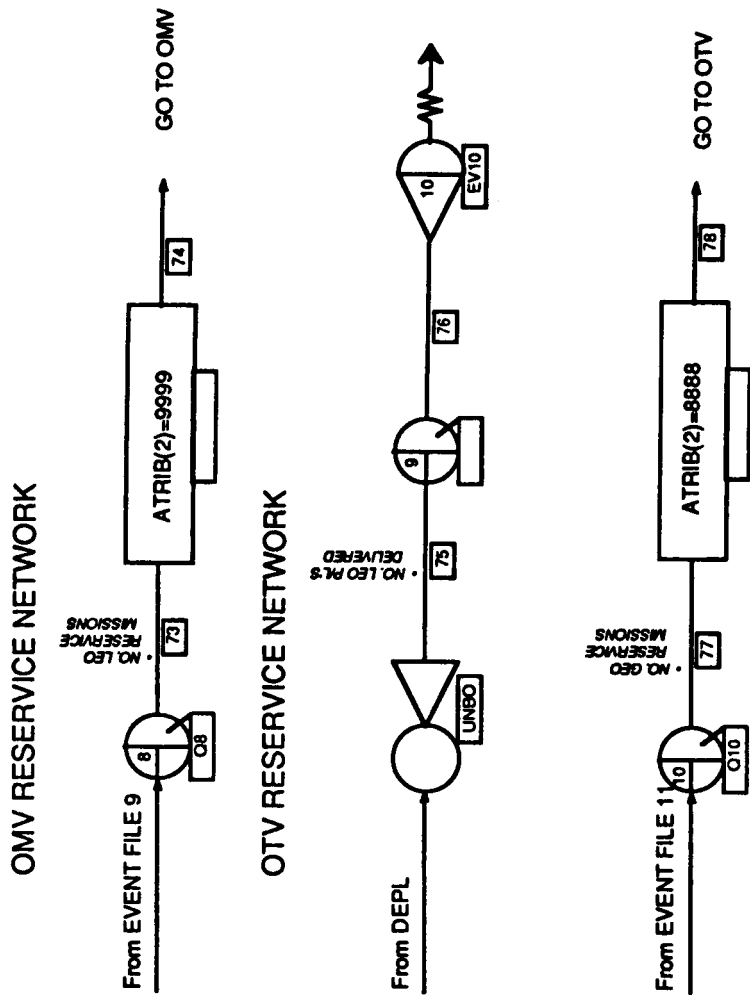

(e) Orbital Operations.

Figure 3. Network Model.

S L A M I I S U M M A R Y R E P O R T

SIMULATION PROJECT STOPS MODEL

BY W.D.MORRIS

DATE 2/23/1987

RUN NUMBER 1 OF 1

CURRENT TIME .8760E+05

STATISTICAL ARRAYS CLEARED AT TIME .0000E+00

FILE STATISTICS

FILE NUMBER	ASSOC LABEL/TYPE	NODE	AVERAGE LENGTH	STANDARD DEVIATION	MAXIMUM LENGTH	CURRENT LENGTH	AVERAGE WAIT TIME
1	POTV	QUEUE	.000	.000	0	0	.000
2	POMV	QUEUE	.000	.000	1	0	.000
3	INPT	QUEUE	.000	.000	0	0	.000
4	MANQ	QUEUE	.008	.112	3	0	2.113
5	SERV	QUEUE	.008	.090	1	0	2.408
6	SSTA	QUEUE	.195	.764	6	0	29.554
7	MOTV	QUEUE	.000	.000	0	0	.000
8	ROMV	QUEUE	.000	.000	0	0	.000
9	DOTV	QUEUE	.003	.074	3	0	1.080
10	ROTV	QUEUE	.000	.000	0	0	.000
11	SCHQ	QUEUE	62.632	28.500	99	90	13682.130
12	AWS	AWAIT	1.195	2.415	15	15	336.506
13	CLR	AWAIT	.012	.109	1	0	3.587
14	AWRM	AWAIT	.317	.746	4	2	40.651
15	PRXD	AWAIT	.010	.101	1	0	4.755
16			.000	.000	0	0	.000
17	A2	AWAIT	.134	.445	4	4	85.108
18	A1	AWAIT	.201	.514	4	1	183.150
19			.000	.000	0	0	.000
20	CALENDAR		225.912	144.243	481	441	854.783

Figure 4. Example of the Standard Output Report.

REGULAR ACTIVITY STATISTICS

ACTIVITY INDEX/LABEL	AVERAGE UTILIZATION	STANDARD DEVIATION	MAXIMUM UTIL	CURRENT UTIL	ENTITY COUNT
1 NO. YRS. MAN	.0000	.0000	1	0	10
2 NO. OTV PROP	.0000	.0000	1	0	119
3 NO. OMV PRPL	.0000	.0000	1	0	10
4 NO. LGS MODS	.0000	.0000	1	0	81
5 NO. P/LS MAN	.0000	.0000	1	0	392
7 BATCHED CARG	.0000	.0000	1	0	311
9 4D/28D TAT	.3244	.5007	2	0	296
10 11D/28D TAT	.8911	.6563	2	1	295
11 ASCENT	.0067	.0818	1	0	295
12 DOCK	.0051	.0709	1	0	295
13 TO NEXT	.0000	.0000	1	0	295
14 VH OFFLD DEL	.1586	.3653	1	0	295
15 VH RET PREP	.0808	.2726	1	0	295
16 FREE CLR	.0000	.0000	1	0	295
17 DESCENT	.0034	.0579	1	0	295
19 FREE VEH	.0000	.0000	1	0	293
20 TO UNBATCH	.0000	.0000	1	0	295
21 TO SSTA	.0000	.0000	7	0	579
23 MMRMS MOVE	.1579	.3646	1	1	576
24 LGS MODULE	.0000	.0000	1	0	78
25 ATTACHED	.0000	.0000	1	0	125
26 OTV PROPELLA	.0000	.0000	1	0	110
27 OMV PROPELLA	.0000	.0000	1	0	10
28 LEO	.0000	.0000	1	0	25
29 GEO	.0000	.0000	1	0	218
30 PLANETARY	.0000	.0000	1	0	10
31 LOG MOVE	.0214	.1446	1	0	78
32 ATT MOVE	.0000	.0000	1	0	125
33 OTV PRPL MOV	.0301	.1710	1	0	110
34 OTV FUEL TRA	.0301	.1710	1	0	110
35 OMV PRPL MOV	.0027	.0523	1	0	10
36 OMV FUEL TRA	.0027	.0523	1	0	10
37 SER LEO P/LS	.0068	.0825	1	0	25
38 GET OMV	.0000	.0000	1	0	25
39 SER GEO P/L	.1195	.3243	1	0	218
40 OTV MANIFEST	.0000	.0000	1	0	218
42 GET OTV /GEO	.0000	.0000	1	0	81
43 SER PLAN	.0055	.0738	1	0	10
44 GET OTV /PLA	.0000	.0000	1	0	10
45 INS/PLAN OMV	.0046	.0676	1	0	134
46 FUEL OMV	.0092	.0954	1	0	134
47 PURGE & DRAI	.0019	.0435	1	0	95
48 INS/PLAN OTV	.0030	.0545	1	0	95
49 R/R ACS MODS	.0093	.0958	1	0	95
50 SYSTEM TEST	.0008	.0285	1	0	95

Figure 4. Continued

51	OMV ACT	.0000	.0000	1	0	138
52	OMV P/L INTE	.0061	.0780	1	0	134
53	LAUNCH OPS	.0000	.0000	1	0	134
54	OMV FLIGHT	.0061	.0780	1	0	134
55	RESER TIME	.0299	.1702	1	0	109
56	DEPLOYMENT	.0003	.0169	1	0	25
57	OMV RET FLIG	.0061	.0780	1	0	134
58	OTV ACT	.0000	.0000	1	0	96
59	OTV P/L INTG	.0057	.0752	1	0	95
60	NO-FUEL AVAI	.0000	.0000	1	0	10
61	OTV FUELING	.0065	.0804	1	0	95
62	ASSIST OTV L	.0062	.0787	1	0	95
63	OTV FLIGHT	.0297	.1698	1	0	95
64	DEPLOY P/LS	.0009	.0302	1	0	80
65	TO UNBATCH	.0000	.0000	1	0	80
66	OTHERWISE	.0000	.0000	1	0	80
67	PLAN DEPLOY	.0001	.0107	1	0	10
68	RES MISSION	.0027	.0523	1	0	5
69	OTV RET FLIG	.0297	.1698	1	0	95
70	RENDEV & CAP	.0054	.0734	1	0	95
71	DOCK	.0016	.0403	1	0	95
72	TO OTV SERVI	.0000	.0000	1	0	95
74	GO TO OMV	.0000	.0000	1	0	113
75	UNB OTV P/LS	.0000	.0000	4	0	212
78	GO TO OTV	.0000	.0000	1	0	5
79	FREED MMRMS	.0000	.0000	1	0	198
80	FREED OMVS	.0000	.0000	1	0	95
81	MAX NO. FLIG	.0000	.0000	1	0	401
82	DET P/LS IN	.0000	.0000	1	0	295
83		.0000	.0000	1	0	36
84		.0000	.0000	1	0	1

****SERVICE ACTIVITY STATISTICS****

ACT NUM	ACT START	LABEL OR NODE	SER CAP	AVERAGE UTIL	STD DEV	CUR UTIL	AVERAGE BLOCK	MAX TME/SER	IDL TME/SER	MAX BSY TME/SER	ENT CNT
0		POTV QUEUE	1	.000	.00	0	.00	2536.83		.00	
0		POMV QUEUE	1	.000	.00	0	.00	33003.62		.00	
6		NO. P/LS TOT	1	.000	.00	0	.00	796.86		.00	602
8		CONT SELECT	1	.000	.00	0	.00	796.36		.00	311
18		13D/28D TAT	2	1.045	.67	2	.00	2.00		2.00	293
22		OFFLOAD P/LS	1	.159	.37	0	.00	700.36		168.00	579
41		OTV MANIFEST	1	.000	.00	0	.00	3957.82		.00	216
73		OMV RESER CN	1	.000	.00	0	.00	18733.85		.00	113
76		TIME BET DPL	1	.002	.05	0	.00	3679.85		4.00	212
77		OTV RESER CN	1	.000	.00	0	.00	82520.85		.00	5

Figure 4. Continued

****RESOURCE STATISTICS****

RESOURCE NUMBER	RESOURCE LABEL	CURRENT CAPACITY	AVERAGE UTIL	STANDARD DEVIATION	MAXIMUM UTIL	CURRENT UTIL
1	SHUT	3	2.54	.669	3	3
2	CLR1	1	.25	.434	1	0
3	MRMS	1	.40	.491	1	1
4	OMV	1	.08	.264	1	0
5	OTV	1	.17	.373	1	0

RESOURCE NUMBER	RESOURCE LABEL	CURRENT AVAILABLE	AVERAGE AVAILABLE	MINIMUM AVAILABLE	MAXIMUM AVAILABLE
1	SHUT	0	.4644	0	3
2	CLR1	1	.7488	0	1
3	MRMS	0	.5956	0	1
4	OMV	1	.9244	0	1
5	OTV	1	.8325	0	1

Figure 4. Concluded.

INPUT DESCRIPTION:

RESERVICE TIME MULTIPLE FOR OMV/LEO PAYLOADS, YEARS -	1.00
RESERVICE TIME MULTIPLE FOR OTV/GEO PAYLOADS, YEARS -	9.00
WEIGHT FOR OMV RESERVICE MODULE, LBS. -	3500.00
WEIGHT FOR OTV RESERVICE MODULE, LBS. -	18000.00
NUMBER OF PLANETARY PAYLOADS REQUIRED TO TRIGGER OTV PROPELLANT FLIGHT -	1.00
NUMBER OF GEO PAYLOADS REQUIRED TO TRIGGER OTV PROPELLANT FLIGHT -	3.00
REORDER POINT FOR OMV PROPELLANT STORED AT THE STATION, LBS. -	50000.00
REORDER POINT FOR OTV PROPELLANT STORED AT THE STATION, LBS. -	200000.00
MAXIMUM SHUTTLE CARGO WEIGHT, LBS. -	65000.00
MAXIMUM SHUTTLE CARGO BAY LENGTH, FT. -	60.00
MAXIMUM NUMBER OF PAYLOADS MANIFESTED PER FLIGHT -	10.00
MAXIMUM OTV CARGO WEIGHT, LBS. -	20000.00
MAXIMUM TOTAL CARGO LENGTH ALLOWED FOR THE OTV, FT. -	40.00
MAXIMUM NUMBER OF PAYLOADS MANIFEST PER FLIGHT -	4.00
PROPELLANT REQUIRED FOR OTV FLIGHT TO GEO WITHOUT CARGO, LBS. -	53935.00
MAXIMUM OTV PROPELLANT REQUIRED FOR PLANETARY FLIGHT BASED ON CAPACITY, LBS. -	85740.00
SCHEDULED LEADTIME FOR OTV PROPELLANT LAUNCH TO SUPPORT RESERVICE, DAYS -	30.00
AVERAGE OMV PROPELLANT DRAWDOWN FOR PROXIMITY OPERATIONS, LBS. -	400.00
AVERAGE OMV PROPELLANT DRAWDOWN FOR LEO MISSIONS, LBS. -	2500.00
PAYLOAD TARE WEIGHT PENALTY FOR THE SHUTTLE, LBS/LINEAR FOOT OF P/L -	280.00
PROPELLANT AS A CARGO WEIGHT (MUST BE LESS THAN XX(18)), LBS. -	55350.00
MAXIMUM NUMBER OF OTV PROPELLANT DELIVERIES TO BE AUTOMATICALLY PRESCHEDULED AT ONE TIME-	2.00

WARNINGS:

WARNING - DELAY DUE TO LOW OTV PROPELLANT LEVEL: TNOW =	2974.34
WARNING - DELAY DUE TO LOW OTV PROPELLANT LEVEL: TNOW =	4543.07
WARNING - DELAY DUE TO LOW OTV PROPELLANT LEVEL: TNOW =	40992.30
WARNING - DELAY DUE TO LOW OTV PROPELLANT LEVEL: TNOW =	43385.59
WARNING - ENTITY LENGTH EXCEEDED OTV PAYLOAD LENGTH CONSTRAINT	
SINGLE OTV PAYLOAD	45990.50 8036.00 10160.00 54.60 6.00
00 .00	
WARNING - DELAY DUE TO LOW OTV PROPELLANT LEVEL: TNOW =	61011.26
WARNING - DELAY DUE TO LOW OTV PROPELLANT LEVEL: TNOW =	63148.76
WARNING - DELAY DUE TO LOW OTV PROPELLANT LEVEL: TNOW =	67264.66
WARNING - DELAY DUE TO LOW OTV PROPELLANT LEVEL: TNOW =	68378.39
WARNING - ENTITY LENGTH EXCEEDED OTV PAYLOAD LENGTH CONSTRAINT	
SINGLE OTV PAYLOAD	80862.04 8036.00 10160.00 54.60 6.00
00 .00	
WARNING - DELAY DUE TO LOW OTV PROPELLANT LEVEL: TNOW =	82660.45
WARNING - DELAY DUE TO LOW OTV PROPELLANT LEVEL: TNOW =	82972.48

Figure 5. Sample User Generated Output.

NOTE: ACTIVITY NO. SHOWN IN BRACKETS

BASE OPERATIONS:

YEAR (NO.)	LAUN (NO.)	CARGO (NO.)	LOGS (NO.)	POTV (NO.)	POMV (NO.)	P/LS (NO.)	TPLS (NO.)
[1]	[11]	[7]	[4]	[2]	[3]	[5]	[6]
0	0	3	1	0	2	0	3
1	25	25	8	10	2	23	43
2	45	45	16	15	2	49	82
3	72	72	24	25	2	78	129
4	100	101	32	36	4	109	181
5	130	132	40	48	4	147	239
6	160	163	48	60	4	191	303
7	194	197	56	72	7	239	374
8	226	229	64	86	7	284	441
9	260	264	72	99	7	338	516
10	295	310	80	119	10	392	601

SPACE STATION OPERATIONS:

YEAR (NO.)	CARG (NO.)	LOG (NO.)	ATT (NO.)	OTVP (NO.)	OMVP (NO.)	LEO (NO.)	GEO (NO.)	PLAN (NO.)
[1]	[20]	[24]	[25]	[26]	[27]	[28]	[29]	[30]
0	0	0	0	0	0	0	0	0
1	25	8	9	10	2	0	8	2
2	45	16	18	15	2	4	25	2
3	72	24	22	24	2	10	43	3
4	100	32	27	35	4	12	65	5
5	130	40	39	46	4	13	89	5
6	160	48	54	59	4	15	111	5
7	194	56	71	70	7	18	139	7
8	226	64	85	84	7	20	165	8
9	260	72	106	97	7	23	193	10
10	295	78	125	110	10	25	218	10

ORBITAL TRANSPORTATION OPERATIONS:

YEAR (NO.)	LEO (NO.)	LRES (NO.)	GEO (NO.)	PLAN (NO.)	GRES (NO.)	TOTV (NO.)	OTV PROP (LBS.)	OMV PROP (LBS.)
[1]	[56]	[55]	[75]	[67]	[68]	[72]		
0	0	0	0	0	0	0	0.	0.
1	0	0	5	2	0	4	269646.	109100.
2	4	0	23	2	0	10	209828.	96700.
3	10	4	41	3	0	19	146335.	68100.
4	12	12	62	4	0	28	133573.	150200.
5	13	24	87	5	0	40	46924.	112900.
6	15	37	109	5	0	49	225620.	71800.
7	18	52	134	7	0	61	41126.	188050.
8	20	70	163	8	0	72	153547.	133650.
9	23	90	191	10	0	83	178568.	74250.
10	25	109	212	10	5	95	61031.	180500.

Figure 5. Continued

DTV PROPELLANT FARM YEARLY SUMMARY:

YEAR	MINIMUM LEVEL	MAXIMUM LEVEL
1	24122.84	269645.70
2	157271.40	267971.40
3	43216.74	265177.60
4	78978.56	312384.60
5	24657.36	189070.50
6	4219.63	225619.60
7	41125.70	287454.50
8	4271.75	153546.60
9	123217.70	374109.40
10	5680.79	288234.70

DMV PROPELLANT FARM YEARLY SUMMARY:

YEAR	MINIMUM LEVEL	MAXIMUM LEVEL
1	55350.00	110700.00
2	96700.00	108700.00
3	68100.00	94200.00
4	47400.00	158100.00
5	112900.00	147700.00
6	71800.00	110400.00
7	46900.00	210050.00
8	133650.00	185550.00
9	74250.00	131150.00
10	42650.00	207900.00

Figure 5. Concluded.

APPENDIX A
Example of the Data File Listing
(STOPS.DAT)

1	8034	1380	8	6	0	0
1	0001	6795	15.7	2	0	0
1	0006	7239	16.4	2	0	0
1	8500	1380	8	6	0	0
1	0201	4190	15.0	2	0	0
1	8725	4960	26.6	6	0	0
1	0307	18630	22	2	0	0
1	8034	1380	8	6	0	0
1	2010	1540	9.8	2	0	0
1	7018	4800	12	7	0	0
1	2020	1100	10	2	0	0
1	8500	1380	8	6	0	0
1	2310	220	4.9	2	0	0
1	8725	4960	26.6	6	0	0
1	2510	660	6.6	2	0	0
1	8034	1380	8	6	0	0
1	2520	22	10	2	0	0
1	7033	2650	7.5	7	0	0
1	8703	1210	8	6	0	0
1	2560	2200	9.8	2	0	0
1	8706	1440	8	6	0	0
1	2570	13670	15	2	0	0
1	8034	1380	8	6	0	0
2	8745	32000	30	5	0	0
2	8034	1380	8	6	0	0
2	0002	7017	16.4	2	0	0
2	8500	1380	8	6	0	0
2	8034	1380	8	6	0	0
2	0003	14550	24	2	0	0
2	8725	4960	26.6	6	0	0
2	0307	18630	22	2	0	0
2	8034	1380	8	6	0	0
				.		
				.		
				.		
				.		
				.		
10	8034	1380	8	6	0	0
10	1213	55000	55	2	0	0
10	8705	1800	14.1	6	0	0
10	8740	3400	30	6	0	0
10	8034	1380	8	6	0	0
10	8727	1210	8	6	0	0
10	0010	2756	9.8	5	0	0

APPENDIX B
Network Program Listing
(STOPS.SLM file)

GEN,W.D.MORRIS, STOPS MODEL,2/23/87,1,Y,Y,Y/Y,,,72;
LIMITS,19,10,900;
PRIORITY/3,HVF(8);
NETWORK;

```

;
;****          PROGRAM TO SIMULATE THE OPERATIONS OF          ****
;****          A SPACE TRANSPORTATION SYSTEM (STOPS)          ****
;****          FINAL NETWORK                                    ****
;

```

```

RESOURCE/SHUT(3),12;
RESOURCE/CLR1(1),13;
RESOURCE/MRMS(1),14,17,18;
RESOURCE/OMV(1),15,17;
RESOURCE/OTV(1),16,18;

```

```

;
;*****
;*****          BASE OPERATIONS          *****
;*****
;*****
;*****

```

```

;*****
;*****          MISSION MANIFEST NETWORK          *****
;*****
;

```

```

;!!!!!!!!!!!!!!!!!!!!!!!!!!!!!!!!!!!!!!!!!!!!!!!!!!!!!!!!!!!!
;          SUPPORT PAYLOADS
;!!!!!!!!!!!!!!!!!!!!!!!!!!!!!!!!!!!!!!!!!!!!!!!!!!!!!!!!!!!!
;

```

```

POTV  QUE(1);
      ACT;
      ASSIGN,ATRIB(1)=TNOW,ATRIB(5)=3;
      ASSIGN,ATRIB(3)=XX(30);
      ASSIGN,ATRIB(8)=3;
      ASSIGN,ATRIB(9)=1;
      ACT/2,,,INPT;  NO. OTV PROP

```

```

POMV  QUE(2),1;
      ACT;
      ASSIGN,ATRIB(1)=TNOW,ATRIB(5)=4;
      ASSIGN,ATRIB(3)=XX(30);
      ASSIGN,ATRIB(8)=3;
      ASSIGN,ATRIB(9)=1;
      ACT/3,,,INPT;

```

```

LOGS  CREATE,1095,0000;          NO. OMV PRPL
      ASSIGN,ATRIB(1)=TNOW,ATRIB(5)=1;  EVERY 45 DAYS
      ASSIGN,ATRIB(8)=2;
      ASSIGN,ATRIB(9)=1;
      ACT/4,,,INPT;          NO. LGS MODS
;

```

```

;!!!!!!!!!!!!!!!!!!!!!!!!!!!!!!!!!!!!!!!!!!!!!!!!!!!!!!!!!!!!!!!!!!!!!!
;          READ & MANIFEST PAYLOADS
;!!!!!!!!!!!!!!!!!!!!!!!!!!!!!!!!!!!!!!!!!!!!!!!!!!!!!!!!!!!!!!!!!!!!!!
;
INIT  CREATE,8760,.5,,;          READ BEG EACH YEAR
      ACT/1,,EV1;              NO. YRS. MANIFEST
EV1   EVENT(1);
      TERM;
;
      ENTER,1,1;              ENTER MANIFEST DATA
      ACT/5;                  NO. P/LS MANIFESTED
;
INPT  QUE(3);
      ACT/6;                  NO. P/LS TOTL
BATS  BATCH,,ATRIB(9),,ALL(10),1;
      ACT/7,,MANQ;          BATCHED CARGO
;
;
;*****END MISSION MANIFEST NETWORK*****
;
;*****SHUTTLE NETWORK*****
;
MANQ  QUE(4),0,,CONT;
SCHQ  QUE(11),,,CONT;
CONT  SELECT,ASM,,MANQ,SCHQ;    CONTROL MAXIMUM FLIGHT RATE
      ACT/8;
;
AWS   AWAIT(12),SHUT;
      ACT/9,96;              4D/28D TAT
LAUN  GOON;
      ACT/10,264;           11D/28D TAT
;
CLR   AWAIT(13),CLR1;
      ACT/11,2;            ASCENT
EV4   EVENT(4);           RECORD LAUNCH TIME
DOCK  GOON,1;
      ACT/12,1.5,,SPL;    DOCK
SPL   GOON,2;
      ACT/20,0,,UNBS;     TO UNBATCH
      ACT/13,,NEXT;      TO NEXT
NEXT  GOON;
      ACT/14,REL(ORB),,DELA;  VH OFFLD DEL
DELA  GOON;
      ACT/15,24,,FCLR;    VH RET PREP DEL
;
FCLR  FREE,CLR1;
      ACT/16,0;          FREE CLR
;
RETN  GOON;
      ACT/17,1;          DESCENT
SERV  QUE(5);
      ACT(2)/18,312;     13D/28D TAT
FSHU  FREE,SHUT;
      ACT/19;          FREE VEH
      TERM;
;
;*****END SHUTTLE NETWORK*****
;

```

```
***** CONTROL CODES **
SCDQ CREATE,219;          SET SCHEDULE(40 FLIGHTS/YEAR)
      ACT/B1,,SCHQ;      MAX NO. FLIGHTS
;
ORB DETECT,NNACT(22),XN,0;
      ACT/B2;          DET P/LS IN Q6
TERM TERM;
;
***** END BASE OPERATIONS *****
;
```



```

;***** OTV PROPELLANTS
;
OTVP GOON;
      ACT/33,24;
      EVENT(5);
      ACT/34,24,,FMRM;
;
;***** OMV PROPELLANTS
;
OMVP GOON;
      ACT/35,24;
      EVENT(6);
      ACT/36,24,,FMRM;
;
;***** LEO
;
LEO GOON;
      ACT/37,24,,;
      FREE,MRMS;
      ACT/38,,OMV;
;
;***** GEO
;
GEO GOON;
      ACT/39,48;
      FREE,MRMS;
      ACT/40;
EV7  EVENT(7);
      TERM;
MOTV QUE(7);
      ACT/41;
BATO BATCH,,ATRIB(10),,,ALL(9),1;
      ACT/42,,OTV;
;
;***** PLANETARY
;
PLAN GOON;
      ACT/43,48;
      FREE,MRMS;
      ACT/44,,OTV;
      TERM;
;
;*****END STATION NETWORK*****
;
;

```

```

OTV PRPL MOVE
TALLY PROPELLANTS
OTV FUEL TRANSFER

```

```

OMV PRPL MOVE
TALLY OMV PROPELLANTS
OMV FUEL TRANSFER

```

```

SER LEO P/LS
GET OMV

```

```

SER GEO P/L
OTV MANIFEST
READ & MANIFEST THE OTV

```

```

OTV MANIFEST
BATCH OTV PAYLOADS
GET OTV /GEO

```

```

SER PLAN
GET OTV /PLAN

```

```

;!!!!!!!!!!!!!!!!!!!!!!!!!!!!!!!!!!!!!!!!!!!!!!!!!!!!!!!!!!!!!!!!!!!!!!!!!!!!!!
;                                TRANSPORTATION NETWORK
;!!!!!!!!!!!!!!!!!!!!!!!!!!!!!!!!!!!!!!!!!!!!!!!!!!!!!!!!!!!!!!!!!!!!!!!!!!!!!!
;
;
;
;***** SERVICE NETWORKS *****
;
;***** OMV SERVICE
;
OMVS GOON;
      ACT/45,3;                                INS/PLAN OMV
EV6  EVENT(6);                                FUEL THE OMV
      ACT;
      GOON,1;
      ACT,REL(DTOMV),ATRIB(4).LT.0,RAS; LOW FUEL DELAY
      ACT/46,6,ATRIB(4).GE.0.;           FUEL OMV
      FREE,OMV;
      TERM;

;
RAS  ASSIGN,ATRIB(4)=0.;                      REASSIGN FLAG
      ACT,,,EV6;

;
;***** OTV SERVICE
;
OTVS GOON;
      ACT/47,1.75;                            PURGE & DRAIN
      GOON;
      ACT/48,2.75;                            INS/PLAN OTV
      AWAIT(14),MRMS;
      ACT/49,8.55;                            R/R ACS MODS
      FREE,MRMS;
      ACT/50,.75;                            SYSTEM TEST
      FREE,OTV;
      TERM;

;
;***** INTEGRATION NETWORK *****
;
;***** OMV ACTIVITIES
;
OMV  GOON,1;
      ACT/51;                                OMV ACT
A2   AWAIT(17),ALLOC(2);
      ACT/52,4;                                OMV P/L INTEG
      FREE,MRMS;
      ACT/53;                                LAUNCH OPS
OMVF GOON;
      ACT/54,4;                                OMV FLIGHT
EV8  EVENT(8);                                READ, SCHED RESERVICE MISSIONS
OMVD GOON,1;
      ACT/55,24,ATRIB(2).EQ.9999,OMVR; RESER TIME
      ACT/56,1;                                DEPLOYMENT
OMVR GOON;
      ACT/57,4,,OMVS;                          OMV RET FLIGHT
      TERM;

;

```

```

;***** OTV ACTIVITIES
;
OTV GOON;          PREFLIGHT
      ACT/58;          OTV ACT
A1  AWAIT(18),ALLO(1);
      ACT/59,5.25;    OTV P/L INTG
      GOON;
      ACT;
OTVF EVENT(5);     FUEL THE OTV
      ACT;
      GOON,1;
      ACT/60,,ATRIB(4).LT.O.,NOFL;    NO-FUEL AVAILABLE
      ACT/61,6.00,ATRIB(4).GE.O.;    OTV FUELING
      FREE,MRMS;
      ACT,,,PRXOP;    GO TO PRXOP
;
; NO FUEL DELAY LOOP FOR THE OTV
NOFL FREE,MRMS;
      ACT,REL(DTOTV);    FUELING DELAY
      ASSIGN,ATRIB(4)=0;  REASSIGN FLAG
      AWAIT(14),MRMS/1;
      ACT,,,OTVF;    TRY AGAIN
;
;***** FLIGHT NETWORK *****
;
PRXOP AWAIT(15),OMV,,2;    WAIT FOR OMV
      ACT/62,5.75,,REFL;    ASSIST OTV LAUNCH
      ACT/63,27.4,,OTVD;    OTV FLIGHT
;
REFL ASSIGN,ATRIB(5)=400;    ID & OMV PROP USAGE FOR PRXOP
      EVENT(6);    REFUEL AFTER PRXOP
      ACT,,,FOMV;    FOMV W/O SERVICING
;
OTVD GOON,1;
      ACT/67,1,ATRIB(5).EQ.7,OTVR;    PLAN DEPLOY
      ACT/68,48,ATRIB(2).EQ.8888,OTVR;  RES MISSION
      ACT/64,1;    DEPLOY P/LS
      GOON,2;
      ACT/65,,,UNBO;    TO UNBATCH
      ACT/66;    OTHERWISE
OTVR GOON;
      ACT/69,27.4;    OTV RET FLIGHT
AWOM AWAIT(15),OMV;
      GOON;
      ACT/70,5;    RENDEV & CAPT
      GOON;
      ACT/71,1.5;    DOCK
      FREE,OMV;
      GOON;
      ACT/72,,,OTVS;    TO OTV SERVICE
;*****END TRANSPORTATION NETWORK*****
;
;*****END SPACE STATION OPERATIONS*****
;

```

```

;*****
;***** ORBITAL OPERATIONS *****
;*****
;***** RESERVICE NETWORKS
;
;***** OMV **
;
ROMV  QUE(8);
      ACT/73;                OMV RESER CNT
      ASSIGN,ATRIB(2)=9999;
      ACT/74,,OMV;          GO TO OMV
;
;***** OTV **
;
UNBO  UNBATCH,9,1;
      ACT/75;                UNB OTV P/LS
DOTV  QUE(9);                SINGLE SERVICE
      ACT(1)/76,1;          TIME BET DPLY
EV10  EVENT(10);            SCHED AN OTV FOR A RESERVICE MISSION
      TERM;
;
ROTV  QUE(10);
      ACT/77;                OTV RESER CNT
      ASSIGN,ATRIB(2)=8888;
      ACT/78,,OTV;          GO TO OTV
      TERM;
;
;*****END ORBITAL OPERATIONS *****
;
;*****
;
;          DISJOINT NETWORKS
;
;*****
;
      CREATE,8760,0;          ONCE EACH YEAR
      EVENT(12);              WRITE OUTPUT FILE
      TERM;
;
FMRM  FREE,MRMS;
      ACT/79;                FREED MRMS
      TERM;
;
FOMV  FREE,OMV;
      ACT/80;                FREED OMVS
      TERM;
;
DTOTV DETECT,XX(33),XP,90000;  DETECT OTV FUEL DELIVERY
      ACT/83;
      TERM;
;
DTOMV DETECT,XX(34),XP,10000;  DETECT OMV FUEL DELIVERY
      ACT/84;
      TERM;
;
;*****
;
END  END;
;

```



```

INITIALIZE,0,87600;
;MONTR,SUMRY,8760;
INTLC,XX(1)=0,XX(2)=0,XX(3)=0,XX(4)=0,XX(5)=0;
;XX(10)=RESERVICE TIME MULTIPLE FOR OMV/LEO PAYLOADS,(YEARS)
INTLC,XX(10)=1;
;XX(11)=RESERVICE TIME MULTIPLE FOR OTV/GEO PAYLOADS,(YEARS)
INTLC,XX(11)=9;
;XX(12)=WEIGHT FOR OMV RESERVICE MODULE,(LBS)
INTLC,XX(12)=3500;
;XX(13)=WEIGHT FOR AN OTV RESERVICE MODULE,(LBS)
INTLC,XX(13)=18000;
;XX(14)=NUMBER OF PLAN PAYLOADS REQUIRED TO TRIGGER OTV PRPL FLIGHT
INTLC,XX(14)=1;
;XX(15)=NUMBER OF GEO PAYLOADS REQUIRED TO TRIGGER OTV PRPL FLIGHT
INTLC,XX(15)=3;
;XX(16)= REORDER POINT FOR OMV PROPELLANT STORED AT THE STATION,(LBS)
INTLC,XX(16)=50000;
;XX(17)=REORDER POINT FOR OTV PROPELLANT STORED AT THE STATION,(LBS)
INTLC,XX(17)=200000;
;XX(18)=MAXIMUM SHUTTLE CARGO WEIGHT,(LBS)
INTLC,XX(18)=65000;
;XX(19)=MAXIMUM SHUTTLE CARGO BAY LENGTH,(FT)
INTLC,XX(19)=60;
;XX(20)=MAXIMUM NUMBER OF SHUTTLE PAYLOADS MANIFEST PER FLIGHT
INTLC,XX(20)=10;
;XX(21)=MAXIMUM OTV CARGO WEIGHT,(LBS)
INTLC,XX(21)=20000;
;XX(22)=MAXIMUM TOTAL CARGO LENGTH ALLOWED FOR THE OTV,(FT)
INTLC,XX(22)=40;
;XX(23)=MAXIMUM NUMBER OF OTV PAYLOADS MANIFEST PER FLIGHT
INTLC,XX(23)=4;
;XX(24)=PROPELLANT REQUIRED FOR OTV FLIGHT TO GEO WITHOUT CARGO,(LBS)
INTLC,XX(24)=53935;
;XX(25)=MAXIMUM OTV PROP REQRED FOR PLANETARY FLIGHT, BASED ON CAPACITY,(LBS)
INTLC,XX(25)=85740;
;XX(26)=SCHEDULED LEADTIME FOR OTV PROP LAUNCH TO SUPPORT RESERVICE,(DAYS)
INTLC,XX(26)=30;
;XX(27)=AVERAGE OMV PROPELLANT DRAWDOWN FOR PROXIMITY OPERATIONS,(LBS)
INTLC,XX(27)=400;
;XX(28)=AVERAGE OMV PROPELLANT DRAWDOWN FOR LEO MISSIONS,(LBS)
INTLC,XX(28)=2500;
;XX(29)=PAYLOAD TARE WEIGHT PENALTY FOR THE SHUTTLE,(LBS/LINEAR FOOT OF P/L)
INTLC,XX(29)=280;
;XX(30)=PROPELLANT AS A CARGO WEIGHT-MUST BE LESS THAN XX(18),(LBS)
INTLC,XX(30)=55350;
;XX(31)=MAX NO OF OTV PROP DELIVERIES TO BE AUTO PRE-SCHEDULED AT ONE TIME
INTLC,XX(31)=2.;
FIN;

```

APPENDIX C
 FORTRAN Event Code Listing
 (STOPS.FOR file)

```

$NOTSTRICT
$STORAGE:2
$LARGE
$NOFLOATCALL
  PROGRAM MAIN
    COMMON/SCOM1/ ATRIB(100),DD(100),DDL(100),DTNOW,II,MFA,MSTOP,NCLNR
1,NCRDR,NPRNT,NNRUN,NNSET,NTAPE,SS(100),SSL(100),TNEXT,TNOW,XX(100)
    NCRDR=5
    NPRNT=0
    NTAPE=7
    OPEN(9,FILE='STOPS.OUT',STATUS='NEW')
    OPEN(8,FILE='STOPS.DAT',STATUS='OLD')
    CALL SLAM
    END
    SUBROUTINE EVENT(IA)
    COMMON/SCOM1/ATTRIB(100),DD(100),DDL(100),DTNOW,II,MFA,MSTOP,NCLNR
1,NCRDR,NPRNT,NNRUN,NNSET,NTAPE,SS(100),SSL(100),TNEXT,TNOW,XX(100)
    INTEGER TOTALP,TOTALG,TCARGO
    COMMON/UCOM1/I1(30),I2(30),I3(30),I4(30),I5(30),I6(30),I7(30),
1I8(30),J1(30),J2(30),J3(30),J4(30),J5(30),J6(30),J7(30),J8(30),
2J9(30),K1(30),K2(30),K3(30),K4(30),K5(30),K6(30),K7(30),P8(30),
3P9(30),P10(30),P11(30),P12(30),P13(30)
    REAL LENGTH
    REAL MAXSHL,MAXSHW
    REAL MAXOTL,MAXOTW
    LOGICAL TFLAG(1000)
    DIMENSION XATTRIB(9,4),YATTRIB(9)
    DIMENSION TATTRIB(9,1000),QATTRIB(9,10,100)
    DIMENSION ZATTRIB(9)
    EQUIVALENCE (XX(4),NGEO)
    EQUIVALENCE (XX(5),NPLAN)
    DATA OTVMIN/3.37E+38/
    DATA OTVMAX/-8.43E-37/
    DATA OMVMIN/3.37E+38/
    DATA OMVMAX/-8.43E-37/
    DATA NOTVP/0/
    DATA NOMVP/0/
    DO 1 I=1,9
      ZATTRIB(I)=0.0
1 CONTINUE
    GO TO (1000,2000,3000,4000,5000,6000,7000,8000,9000,10000,11000,
1 12000),IA
1000 CONTINUE
C
C   EVENT ONE - SHUTTLE PAYLOAD MANIFESTING
C
C   ATRIB(1) = DATE PAYLOAD WILL BE READY FOR LAUNCH - MONTH, DAY, YEAR
C   ATRIB(2) = MARSHALL MISSION ID
C   ATRIB(3) = PAYLOAD WEIGHT, LBS
C   ATRIB(4) = PAYLOAD LENGTH, FT

```

```

C      ATRIB(5) = TYPE OR DESTINATION
C      WHERE 1 = LOGISTICS
C           2 = ATTACHED
C           3 = OTV PROPELLANT
C           4 = OMV PROPELLANT
C           5 = LEO
C           6 = GEO
C           7 = PLANETARY
C      ATRIB(6) = RESERVICING SCHEDULE, YEARS
C      ATRIB(7) = LIFETIME, YEARS
C      ATRIB(8) = 1, SETS MANIFESTED PAYLOADS TO LOWEST PRIORITY
C                IN QUEUE 3
C      ATRIB(9) = THRESHOLD FOR SHUTTLE CARGO
C      NOTE: ATRIB(1) THRU ATRIB(7) ARE READ FROM THE FILE STOPS.DAT.
C            PRESENTLY ATRIB(6) AND (7) ARE NOT USED AND HAVE A VALUE
C            OF ZERO IN THE INPUT FILE. ATRIB(8) AND ATRIB(9) ARE
C            SET IN EVENT ONE.
C      TNOW = SIMULATION CLOCK TIME, HRS
C
C      WRITE(9,50000)
50000 FORMAT(1X,'EVENT ONE - SHUTTLE PAYLOAD MANIFESTING')
C      WRITE(9,50001) TNOW
50001 FORMAT(1X,'TNOW = ',F10.2)
C
C      INITIALIZATION
C
C      XX(18) - MAXIMUM SHUTTLE CARGO WEIGHT, LBS
MAXSHW=XX(18)
C      XX(19) - MAXIMUM SHUTTLE CARGO LENGTH, FT
MAXSHL=XX(19)
C      XX(20) - MAXIMUM NUMBER OF PAYLOADS MANIFEST PER YEAR
MAXSHTP=XX(20)
WEIGHT=0.
LENGTH=0.
C      TOTALP - COUNTER OF PLANETARY PAYLOADS FOR THE CURRENT YEAR
TOTALP=0
C      TOTALG - COUNTER OF GEO PAYLOADS FOR THE CURRENT YEAR
TOTALG=0
C      NCARGO - CARGO NUMBER
NCARGO=1
C      NUMBER - NUMBER OF PAYLOADS IN CURRENT CARGO
NUMBER=0
C      NTATRIB - NUMBER OF ELEMENTS IN ARRAY TATRIB
NTATRIB=0
C      TFLAG - ARRAY OF FLAGS ASSOCIATED WITH ARRAY TATRIB
DO 1001 I=1,500
    TFLAG(I)=.TRUE.
1001 CONTINUE
C      TIME - YEAR CURRENT PROCESSING
TIME=TNOW/8760.+1.
1002 CONTINUE
    NTATRIB=NTATRIB+1
C      PAYLOADS ARE READ FROM STOPS.DAT AND THOSE WITH A LAUNCH DATE
C      OF THE YEAR CURRENTLY PROCESSING ARE PLACED IN ARRAY TATRIB
    READ(8,*,END=1003) (TATRIB(J,NTATRIB),J=1,7)
C      WRITE(9,50002) (TATRIB(J,NTATRIB),J=1,7)
50002 FORMAT(20X,'READ FROM FILE 8 - ',3F10.0,2(F10.1,F10.0))
C      DETERMINE IF PAYLOAD IS READY FOR LAUNCH
C      YEAR - YEAR PAYLOAD IS READY FOR LAUNCH
YEAR=TATRIB(1,NTATRIB)

```

```

        IF (YEAR.LE.TIME) THEN
            IF (TATRIB(5,NTATRIB).EQ.7) TOTALP=TOTALP+1
            IF (TATRIB(5,NTATRIB).EQ.6) TOTALG=TOTALG+1
            GO TO 1002
        ENDIF
        BACKSPACE 8
1003 CONTINUE
        NTATRIB=NTATRIB-1
        IF (NTATRIB.NE.0) GO TO 1005
C      WRITE(9,50003) TNOW
50003 FORMAT(1H0,' FILE 8 IS EMPTY AT TIME ',F10.2)
        RETURN
1004 CONTINUE
        WEIGHT=0.
        LENGTH=0.
1005 CONTINUE
C      NUM - POINTER TO CURRENT POSITION IN ARRAY TATRIB
        NUM=0
1006 CONTINUE
        NUM=NUM+1
        IF (NUM.GT.NTATRIB) GO TO 1012
C      IF AN INDIVIDUAL PAYLOAD EXCEEDS MAXIMUM WEIGHT OR LENGTH
C      CONSTRAINT, THE PAYLOAD IS NOT USED
        IF (TATRIB(3,NUM).LE.MAXSHW.AND.TATRIB(4,NUM).LE.MAXSHL)
1      GO TO 1007
        IF (TATRIB(3,NUM).GT.MAXSHW) THEN
            WRITE(NPRNT,50004) XX(18),(TATRIB(I,NUM),I=1,7)
            WRITE(9,50004) XX(18),(TATRIB(I,NUM),I=1,7)
50004 FORMAT(' WARNING - MAXIMUM SHUTTLE CARGO WEIGHT CONSTRAINT OF',
1          F10.0,1X,'LBS WAS EXCEEDED',/,1X,'THE FOLLOWING',
2          ' PAYLOAD WAS IGNORED:',/,3F10.0,2(F10.1,F10.0))
        ELSE
            WRITE(NPRNT,50005) XX(19),(TATRIB(I,NUM),I=1,7)
            WRITE(9,50005) XX(19),(TATRIB(I,NUM),I=1,7)
50005 FORMAT(' WARNING - MAXIMUM SHUTTLE CARGO LENGTH CONSTRAINT OF',
1          F10.0,1X,'FT WAS EXCEEDED',/,1X,'THE FOLLOWING',
2          ' PAYLOAD WAS IGNORED:',/,3F10.0,2(F10.1,F10.0))
        ENDIF
        TFLAG(NUM)=.FALSE.
        GO TO 1006
1007 CONTINUE
C      DETERMINE IF WEIGHT IS EXCEEDED
C      XX(29) - PAYLOAD TARE WEIGHT PENALTY FOR THE SHUTTLE, LBS/LINEAR
C      FT OF PAYLOAD
        WEIGHT=WEIGHT+TATRIB(3,NUM)+XX(29)*TATRIB(4,NUM)
        IF (WEIGHT.GT.MAXSHW.AND.NUMBER.EQ.0) GO TO 1010
        IF (WEIGHT.GT.MAXSHW.AND.NUMBER.NE.0) GO TO 1009
C      DETERMINE IF LENGTH IS EXCEEDED
        LENGTH=LENGTH+TATRIB(4,NUM)
        IF (LENGTH.GT.MAXSHL.AND.NUMBER.EQ.0) GO TO 1010
        IF (LENGTH.GT.MAXSHL.AND.NUMBER.NE.0) GO TO 1008
        GO TO 1010
1008 CONTINUE
        LENGTH=LENGTH-TATRIB(4,NUM)
1009 CONTINUE
        WEIGHT=WEIGHT-TATRIB(3,NUM)-280.*TATRIB(4,NUM)
        GO TO 1006
1010 CONTINUE
C      CORRESPONDING ELEMENT (NUM) IN ARRAY TATRIB HAS BEEN PLACED
C      IN CARGO

```

```

TFLAG(NUM)=.FALSE.
NUMBER=NUMBER+1
DO 1011 I=1,7
  QATRIB(I,NUMBER,NCARGO)=TATRIB(I,NUM)
1011 CONTINUE
C   DETERMINE IF CARGO IS COMPLETE
  IF(NUMBER.EQ.MAXSHTP.OR.TATRIB(5,NUM).EQ.1.OR.
1   WEIGHT.GT.MAXSHW.OR.LENGTH.GT.MAXSHL) GO TO 1012
  GO TO 1006
1012 CONTINUE
C   SET ATRIB(8) AND ATRIB(9) FOR EACH PAYLOAD IN THE CARGO
  DO 1013 I=1,NUMBER
    QATRIB(8,I,NCARGO)=1
    QATRIB(9,I,NCARGO)=NUMBER
1013 CONTINUE
C   WRITE(9,50006)
50006 FORMAT(1X,'CARGOS')
  DO 1014 I=1,NUMBER
C     WRITE(NPRNT,50007) NCARGO,(QATRIB(J,I,NCARGO),J=1,9)
C     WRITE(9,50007) NCARGO,(QATRIB(J,I,NCARGO),J=1,9)
50007 FORMAT(15,(3F10.0,2(F10.1,F10.0),2F10.0))
1014 CONTINUE
  NCARGO=NCARGO+1
  NUMBER=0
C   REORDER TATRIB ARRAY
  IF(NTATRIB.EQ.0) GO TO 1018
C   WRITE(9,50008)
50008 FORMAT(1X,'REORDERED ARRAY')
  N=0
  DO 1017 I=1,NTATRIB
    IF(.NOT.TFLAG(I)) GO TO 1016
    N=N+1
    DO 1015 J=1,7
      TATRIB(J,N)=TATRIB(J,I)
      TFLAG(N)=.TRUE.
1015 CONTINUE
C   WRITE(9,50009) (TATRIB(K,N),K=1,7)
50009 FORMAT(3F10.0,2(F10.1,F10.0))
1016 CONTINUE
1017 CONTINUE
  NTATRIB=N
  IF(NTATRIB.NE.0) GO TO 1004
1018 CONTINUE
C   MANIFESTING COMPLETE
  NCARGO=NCARGO-1
C   SPREAD CARGOS OUT OVER THE YEAR
C   XX(14) - NUMBER OF PLANETARY PAYLOADS REQUIRED TO TRIGGER AN OTV
C   PROPELLANT DELIVERY FLIGHT
C   NP=XX(14)
C   XX(15) - NUMBER OF GEO PAYLOADS REQUIRED TO TRIGGER AN OTV
C   PROPELLANT DELIVERY FLIGHT
C   NG=XX(15)
  TCARGO=NCARGO+TOTALP/NP+TOTALG/NG
C   WRITE(9,50010) NCARGO,TOTALP,TOTALG,TCARGO
50010 FORMAT(1X,'NCARGO = ',15,1X,'TOTALP = ',15,1X,'TOTALG = ',
1 15,1X,'TCARGO = ',15)
  TINC=8760./(TCARGO+1)
C   WRITE(9,50011) TINC
50011 FORMAT(1X,'TINC = ',F10.2)
  N=0

```

```

DO 1022 I=1,NCARGO
  NPLS=QATRIB(9,1,I)
  DO 1019 J=1,NPLS
    ATRIB(5)=QATRIB(5,J,I)
  C     DETERMINE IF IT IS NECESSARY TO SCHEDULE AN OTV PROPELLANT
  C     FLIGHT -
  C     SCHEDULE AN OTV PROPELLANT FLIGHT WHEN XX(14) PLANETARY
  C     OR XX(15) GEO PAYLOADS ARE MANIFESTED
    IF(ATRIB(5).EQ.7) THEN
      NPLAN=NPLAN+1
  C     SCHEDULE AN OTV PROPELLANT FLIGHT DUE TO XX(14) PLANETARY
  C     PAYLOADS MANIFESTED
      IF(NPLAN.EQ.NP) THEN
        N=N+1
        TSCHDL=N*TINC+TNOW
        TIMINC=TSCHDL-TNOW
  C     SCHEDULE A CALL TO EVENT TWO ON THE EVENT CALENDAR
        CALL SCHDL(2,TIMINC,ZATRIB)
        NOTVP=NOTVP+1
  C     WRITE(NPRNT,50012) TSCHDL,NOTVP
  C     WRITE(9,50012) TSCHDL,NOTVP
50012     FORMAT(1X,'SCHEDULE AN OTV PROPELLANT FLIGHT AT TIME ',
1         F10.2,' DUE TO A PLANETARY PAYLOAD MANIFESTED, NOTVP = ',
2         I5)
        NPLAN=0
      ENDIF
    ENDIF
    IF(ATRIB(5).EQ.6) THEN
      NGE0=NGE0+1
  C     SCHEDULE AN OTV PROPELLANT FLIGHT DUE TO XX(15) GEO PAYLOADS
  C     MANIFESTED
      IF(NGE0.EQ.NG) THEN
        N=N+1
        TSCHDL=N*TINC+TNOW
        TIMINC=TSCHDL-TNOW
  C     SCHEDULE A CALL TO EVENT TWO ON THE EVENT CALENDAR
        CALL SCHDL(2,TIMINC,ZATRIB)
        NOTVP=NOTVP+1
  C     WRITE(NPRNT,50013) TSCHDL,NOTVP
  C     WRITE(9,50013) TSCHDL,NOTVP
50013     FORMAT(1X,'SCHEDULE AN OTV PROPELLANT FLIGHT AT TIME ',
1         F10.2,' DUE TO 3 GEO PAYLOADS MANIFESTED, NOTVP = ',I5)
        NGE0=0
      ENDIF
    ENDIF
1019   CONTINUE
      N=N+1
      TSCHDL=N*TINC+TNOW
      DO 1021 J=1,NPLS
  C     EACH PAYLOAD IN A MANIFESTED CARGO IS GIVEN THE SAME LAUNCH
  C     TIME
        ATRIB(1)=TSCHDL
        DO 1020 K=2,9
          ATRIB(K)=QATRIB(K,J,I)
1020     CONTINUE
        TIMINC=ATRIB(1)-TNOW
  C     SCHEDULE A CALL TO EVENT THREE ON THE EVENT CALENDAR
        CALL SCHDL(3,TIMINC,ATRIB)
  C     WRITE(9,50014) (ATRIB(L),L=1,9)
50014     FORMAT(3F10.0,2(F10.1,F10.0),2F10.0)

```

```

1021     CONTINUE
1022 CONTINUE
      RETURN
2000 CONTINUE
C
C     EVENT TWO - SCHEDULING AN OTV PROPELLANT LAUNCH DUE TO EITHER
C             XX(14) PLANETARY OR XX(15) GEO SHUTTLE PAYLOADS
C             MANIFESTED OR DUE TO AN OTV RESERVICE MISSION
C
C     WRITE(9,50015)
50015 FORMAT(1X,'EVENT TWO - ENTER AN OTV PROPELLANT MISSION IN THE',
1      ' NETWORK')
C     WRITE(9,50001) TNOW
C     INSERT AN OTV PROPELLANT DELIVERY MISSION INTO THE NETWORK BY
C     PLACING AN ENTITY INTO FILE 1
C     CALL FILEM(1,ZATRIB)
C     RETURN
3000 CONTINUE
C
C     EVENT THREE - PLACE PAYLOAD ENTITY INTO THE NETWORK AT THE
C             ENTER NODE
C
C     WRITE(9,50016)
50016 FORMAT(1X,'EVENT THREE - PLACE PAYLOAD ENTITY INTO THE NETWORK')
C     WRITE(NPRNT,50001) TNOW
C     CALL ENTER(1,ATRIB)
C     RETURN
4000 CONTINUE
C
C     EVENT FOUR - PRINT LAUNCH TIME AND ENTITY ATTRIBUTES
C
C     WRITE(9,50017)
50017 FORMAT(1X,'EVENT FOUR - LAUNCH')
C     WRITE(9,50018) TNOW,(ATRIB(J),J=1,9)
50018 FORMAT(15X,'TNOW = ',F10.2,/,15X,3F10.0,F10.1,F10.0,F10.1,
1      3F10.0)
C     RETURN
5000 CONTINUE
C
C     EVENT FIVE - OTV PROPELLANT FARM
C
C     WRITE(9,50019)
50019 FORMAT(1X,'EVENT FIVE - OTV PROPELLANT FARM')
C     WRITE(9,50001) TNOW
C     XX(2)=XX(2)+1
C     IF(XX(2).EQ.1) WP=0
C     DETERMINE IF MISSION IS AN OTV RESERVICE OPERATION
C     IF(ATRIB(2).EQ.8888) THEN
C         ATRIB(1)=0.0
C     XX(13) - WEIGHT FOR AN OTV RESERVICE MODULE, LBS
C         ATRIB(3)=XX(13)
C         DO 5001 I=4,9
C             ATRIB(I)=0.0
5001     CONTINUE
C         ENDIF
C     OTV PROPELLANT DELIVERY
C     IF(ATRIB(5).EQ.3) THEN
C         WP=WP+ATRIB(3)
C         NOTVP=NOTVP-1
C     WRITE(9,80000) TNOW,WP,NOTVP

```

```

80000  FORMAT(' OTV PROP. DEL. - TNOW = ',F10.2,2X,' PROP. LEVEL = ',
1      F10.2,2X,' NOTVP = ',I5)
      XX(33)=WP
C      WRITE(9,50020) ATRIB(3),WP,TNOW,(ATRIB(J),J=1,7)
50020  FORMAT(16X,'DELIVERY - AMT. DELIVERED = ',F10.2,2X,'AMT. ',
1      'STORED = ',F10.2,2X,'TNOW = ',F10.2,/,27X,3F10.0,F10.1,
2      F10.0,F10.1,F10.0)
      ELSE
C      FUEL THE OTV
C      XX(24) - PROPELLANT REQUIRED FOR OTV FLIGHT TO GED WITH
C      CARGO, LBS
      WPOTV=1.632*ATRIB(3)+XX(24)
C      XX(25) - MAXIMUM OTV PROPELLANT REQUIRED FOR PLANETARY FLIGHT,
C      BASED ON CAPACITY (LBS)
      IF(ATRIB(5).EQ.7) WPOTV=XX(25)
      WP=WP-WPOTV
      IF(WP.LT.0) THEN
60000  WRITE(9,60000)TNOW
1      FORMAT(' WARNING - DELAY DUE TO LOW OTV PROPELLANT LEVEL:',
2      ' TNOW = ',F10.2)
      ATRIB(4)=-1.
      WP=WP+WPOTV
      ENDIF
      XX(33)=WP
C      WRITE(9,50021) WPOTV,WP,TNOW,(ATRIB(J),J=1,7)
50021  FORMAT(16X,'USAGE - AMT. USED = ',F10.2,2X,'AMT. STORED = ',
1      F10.2,2X,'TNOW = ',F10.2,/,27X,3F10.0,F10.1,F10.0,F10.1,
2      F10.0)
      ENDIF
      IF(WP.LT.OTVMIN) OTVMIN=WP
      IF(WP.GT.OTVMAX) OTVMAX=WP
C      CHECK OTV PROPELLANT LEVEL AT THE STATION
C      XX(17) - REORDER POINT FOR OTV PROPELLANT STORED AT THE STATION,
C      LBS
      IF(WP.GE.XX(17)) RETURN
C      XX(31) - MAXIMUM NUMBER OF OTV PROPELLANT DELIVERIES TO BE
C      AUTOMATICALLY PRESCHEDULED AT ONE TIME
      IF(NOTVP.GT.XX(31)) THEN
C      WRITE(9,80006)
80006  FORMAT(' OTV PROP. LOW BUT NOT ORDERED BECAUSE DELIVERY IS',
1      ' SCHEDULED')
      RETURN
      ENDIF
      NOTVP=NOTVP+1
C      WRITE(9,80001) TNOW,WP,NOTVP
80001  FORMAT(' OTV PROP. ORDER - TNOW = ',F10.2,2X,' PROP. LEVEL = ',
1      F10.2,2X,' NOTVP = ',I5)
C      SCHEDULE A PROPELLANT FLIGHT
C      WRITE(9,50022)
50022  FORMAT(16X,33HSCHEDULE AN OTV PROPELLANT FLIGHT)
      CALL FILEM(1,ZATRIB)
      RETURN
6000  CONTINUE
C
C      EVENT SIX - OMV PROPELLANT FARM
C
C      WRITE(9,50023)
50023  FORMAT(1X,'EVENT SIX - OMV PROPELLANT FARM')
C      WRITE(9,50001) TNOW
      XX(3)=XX(3)+1

```



```

        IF (XX(3).EQ.1) OMVF=0
C       DETERMINE IF MISSION IS AN OMV RESERVICE MISSION
C       XX(12) - WEIGHT FOR AN OMV RESERVICE MODULE, LBS
        IF (ATRIB(2).EQ.9999) THEN
            ATRIB(1)=0.0
            ATRIB(3)=XX(12)
            DO 6001 I=4,9
                ATRIB(I)=0.0
6001    CONTINUE
        ENDIF
        IF (ATRIB(5).EQ.4) GO TO 6002
        IF (ATRIB(5).EQ.400) THEN
C       XX(27) - AVERAGE OMV PROPELLANT DRAWDOWN FOR PROXIMITY
C       OPERATIONS, LBS
            OMVF=OMVF-XX(27)
            IF (OMVF.LT.0) THEN
                WRITE(9,60001) TNOW
60001    FORMAT(' WARNING - DELAY DUE TO LOW OMV PROPELLANT LEVEL: ',
1         ' TNOW = ',F10.2)
                ATRIB(4)=-1.
                OMVF=OMVF+XX(27)
            ENDIF
        ELSE
C       XX(28) - AVERAGE OMV PROPELLANT DRAWDOWN FOR LEO MISSION, LBS
            OMVF=OMVF-XX(28)
            IF (OMVF.LT.0) THEN
C       WRITE(9,60001) TNOW
                ATRIB(4)=-1.
                OMVF=OMVF+XX(28)
            ENDIF
        ENDIF
        XX(34)=OMVF
C       WRITE(9,50024) OMVF, TNOW, (ATRIB(J), J=1,7)
50024    FORMAT(16X,11HUSAGE - ,17HAMT. USED = 2500.,2X,14HAMT. STORED =
1 ,F10.2,2X,7HTNOW = ,F10.2,/,27X,3F10.0,F10.1,F10.0,F10.1,F10.0)
        GO TO 6003
6002    OMVF=OMVF+ATRIB(3)
        NOMVP=NOMVP-1
C       WRITE(9,80002) TNOW, OMVF, NOMVP
80002    FORMAT(' OMV PROP. DEL. - TNOW = ',F10.2,2X,' PROP. LEVEL = ',
1         F10.2,2X,' NOMVP = ',I5)
        XX(34)=OMVF
C       WRITE(9,50025) OMVF, TNOW, (ATRIB(J), J=1,7)
50025    FORMAT(16X,11HDELIVERY - ,23HAMT. DELIVERED = 55350.,2X,14HAMT. ST
10RED = ,F10.2,2X,7HTNOW = ,F10.2,/,27X,3F10.0,F10.1,F10.0,F10.1,
2F10.0)
6003    CONTINUE
        IF (OMVF.LT.OMVMIN) OMVMIN=OMVF
        IF (OMVF.GT.OMVMAX) OMVMAX=OMVF
C       CHECK OMV PROPELLANT LEVEL AT THE STATION
C       XX(16) - REORDER POINT FOR OMV PROPELLANT AT THE STATION, LBS
        IF (OMVF.GE.XX(16)) RETURN
        IF (NOMVP.GT.0) THEN
C       WRITE(9,80004) NOMVP
80004    FORMAT(' OMV PROP. LOW BUT NOT ORDERED BECAUSE DELIVERY IS',
1         ' SCHEDULED, NOMVP = ',I5)
            RETURN
        ENDIF
        NOMVP=NOMVP+1
C       WRITE(9,80003) TNOW, OMVF, NOMVP

```

```

80003 FORMAT(' DMV PROP. ORDERED - TNOW = ',F10.2,2X,' PROP. LEVEL = ',
1      F10.2,2X,' NOMVP = ',I5)
C      SCHEDULE A PROPELLANT FLIGHT
C      WRITE(9,50026)
50026 FORMAT(16X,33HSCHEDULE AN DMV PROPELLANT FLIGHT)
      CALL FILEM(2,ZATRIB)
      RETURN
7000 CONTINUE
C
C      EVENT SEVEN - OTV PAYLOAD MANIFESTING
C
C      WRITE(9,50027)
50027 FORMAT(1X,'EVENT SEVEN - OTV PAYLOAD MANIFESTING')
C      WRITE(9,50001) TNOW
C      XX(21) - MAXIMUM OTV CARGO WEIGHT, LBS
      MAXOTW=XX(21)
C      XX(22) - MAXIMUM OTV CARGO LENGTH, FT
      MAXOTL=XX(22)
C      XX(23) - MAXIMUM NUMBER OF PAYLOADS MANIFESTED PER FLIGHT
      MAXOTVP=XX(23)
C      TEST INDIVIDUAL WEIGHT TO DETERMINE IF WITHIN
C      CONSTRAINTS - IF NOT, PRINT ERROR MESSAGE
      IF(ATRIB(3).GT.MAXOTW) GO TO 7009
      XX(1)=XX(1)+1
      IF(XX(1).EQ.1) THEN
          NUMOTVP=0
          TOTALL=0
          TOTALW=0
      ENDIF
      TOTALL=TOTALL+ATRIB(4)
      IF(TOTALL.GT.MAXOTL) GO TO 7001
      TOTALW=TOTALW+ATRIB(3)
      IF(TOTALW.GT.MAXOTW) GO TO 7001
      NUMOTVP=NUMOTVP+1
7001 CONTINUE
      DO 7002 I=1,7
          YATRIB(I)=ATRIB(I)
          IF(NUMOTVP.EQ.0.AND.ATRIB(4).GT.MAXOTL) XATRIB(I,1)=ATRIB(I)
9999      FORMAT(' WARNING - ENTITY LENGTH EXCEEDED OTV PAYLOAD',
1          ' LENGTH CONSTRAINT',/, ' SINGLE OTV PAYLOAD ',2X,
2          7F10.2)
          IF(NUMOTVP.EQ.MAXOTVP) XATRIB(I,NUMOTVP)=ATRIB(I)
7002 CONTINUE
          IF(NUMOTVP.EQ.0.AND.ATRIB(4).GT.MAXOTL) THEN
              NUMOTVP=1
              WRITE(9,9999) (XATRIB(I,1),I=1,7)
              GO TO 7010
          ENDIF
          IF(NUMOTVP.LT.MAXOTVP.AND.TOTALL.LE.MAXOTL.AND.TOTALW.LE.MAXOTW)
1      GO TO 7007
C      PLACE PAYLOADS IN QUEUE 7
7010 CONTINUE
      DO 7004 J=1,NUMOTVP
          DO 7003 I=1,7
              ATRIB(I)=XATRIB(I,J)
7003      CONTINUE
C      WRITE(9,50028) J,(ATRIB(K),K=1,7)
50028  FORMAT(14X,I5,3F10.0,F10.1,F10.0,F10.1,F10.0)
      ATRIB(10)=NUMOTVP
      CALL FILEM(7,ATRIB)

```

```

7004 CONTINUE
C   WRITE(9,50029) NUMOTVP,TNOW
50029 FORMAT(40H NUMBER OF PAYLOADS PLACED IN QUEUE 7 = ,I5,5X,
17HTNOW = ,F10.2)
   ATRIB(1)=NUMOTVP
   ATRIB(3)=TOTALW
   IF(NUMOTVP.EQ.1.AND.ATRIB(4).GT.MAXOTL) GO TO 7005
   IF(NUMOTVP.LT.MAXOTVP) GO TO 7006
7005 NUMOTVP=0
   TOTAL=0
   TOTALW=0
   RETURN
7006 CONTINUE
   NUMOTVP=1
   TOTAL=YATRIB(4)
   TOTALW=YATRIB(3)
C   PLACE ATTRIBUTES IN A TEMPORARY ARRAY
7007 CONTINUE
   DO 7008 I=1,7
       XATRIB(I,NUMOTVP)=YATRIB(I)
7008 CONTINUE
   RETURN
7009 CONTINUE
C   WRITE(9,50030) ATRIB(3)
50030 FORMAT(1X,'EVENT SEVEN - INDIVIDUAL PAYLOAD EXCEEDED WEIGHT CONSTR
1AINTS',/,10X,'WEIGHT = ',F10.2)
   RETURN
8000 CONTINUE
C
C   EVENT EIGHT - SCHEDULING OMV RESERVICE ON THE EVENT CALENDAR
C
C   WRITE(9,50031)
50031 FORMAT(1X,'EVENT EIGHT - SCHEDULING OMV RESERVICE ON THE EVENT',
1      ' CALENDAR')
C   WRITE(9,50001) TNOW
C   XX(10) - RESERVICE TIME MULTIPLE FOR OMV/LEO PAYLOADS
   TSCHED=XX(10)*8760.
C   SCHEDULE A RESERVICE MISSION TO LEO ON THE EVENT CALENDAR
C   (SCHEDULE EVENT NINE)
   CALL SCHDL(9,TSCHED,ATRIB)
   RETURN
9000 CONTINUE
C
C   EVENT NINE - PLACING OMV RESERVICE OPERATION IN THE NETWORK
C
C   WRITE(9,50032)
50032 FORMAT(1X,'EVENT NINE - PLACING AN OMV RESERVICE MISSION IN THE'
1      ' NETWORK')
C   WRITE(9,50001) TNOW
C   ENTER A RESERVICE MISSION TO LEO INTO THE NETWORK BY PLACING
C   AN ENTITY IN FILE 8
   CALL FILEM(8,ATRIB)
C   WRITE(9,50033) TNOW,(ATRIB(J),J=1,7)
50033 FORMAT(15X,7HTNOW = ,F10.2,/,15X,3F10.0,F10.1,F10.0,F10.1,F10.0)
   RETURN
10000 CONTINUE
C
C   EVENT TEN - SCHEDULING OTV RESERVICE ON THE EVENT CALENDAR
C
C   WRITE(9,50034)

```

```

50034 FORMAT(1X,'EVENT TEN - SCHEDULING OTV RESERVICE ON THE EVENT',
1      ' CALENDAR')
C      WRITE(9,50001) TNOW
C      XX(11) - RESERVICE TIME MULTIPLE FOR OTV/GEO PAYLOADS
      TSCHED=XX(11)*8760.
C      SCHEDULE A RESERVICE MISSION TO GEO ON THE EVENT CALENDAR
C      (SCHEDULE EVENT ELEVEN)
      CALL SCHDL(11,TSCHED,ATRIB)
      TEMP=TSCHED+TIME
C      WRITE(9,50035) TEMP
50035 FORMAT(1X,'OTV RESERVICE SCHEDULED AT TIME ',F10.2)
C      XX(26) - SCHEDULED LEADTIME FOR OTV PROPELLANT LAUNCH TO SUPPORT
C      RESERVICE, DAYS
      TSCHED=TSCHED-XX(26)*24.
      CALL SCHDL(2,TSCHED,ZATRIB)
C      NOTVP=NOTVP+1
      TEMP=TEMP+TNOW
C      WRITE(9,50036) TEMP,NOTVP
50036 FORMAT(1X,'SCHEDULE AN OTV PROPELLANT FLIGHT DUE TO AN OTV',
1      ' RESERVICE MISSION AT TIME ',F10.2,2X,'NOTVP = ',I5)
      RETURN
11000 CONTINUE
C
C      EVENT ELEVEN - PLACING OTV RESERVICE OPERATION IN THE NETWORK
C
C      WRITE(9,50037)
50037 FORMAT(1X,'EVENT ELEVEN - PLACING OTV RESERVICE OPERATION IN THE',
1      ' NETWORK')
C      WRITE(9,50001) TNOW
      CALL FILEM(10,ATRIB)
      RETURN
12000 CONTINUE
C
C      EVENT TWELVE- WRITE OUTPUT FILE
      I=INT(TNOW/8760)
      I1(I)=NNCNT(1)
      I2(I)=NNCNT(11)
      I3(I)=NNCNT(7)
      I4(I)=NNCNT(4)
      I5(I)=NNCNT(2)
      I6(I)=NNCNT(3)
      I7(I)=NNCNT(5)
      I8(I)=NNCNT(6)
      J1(I)=NNCNT(1)
      J2(I)=NNCNT(20)
      J3(I)=NNCNT(24)
      J4(I)=NNCNT(25)
      J5(I)=NNCNT(26)
      J6(I)=NNCNT(27)
      J7(I)=NNCNT(28)
      J8(I)=NNCNT(29)
      J9(I)=NNCNT(30)
      K1(I)=NNCNT(1)
      K2(I)=NNCNT(56)
      K3(I)=NNCNT(55)
      K4(I)=NNCNT(75)
      K5(I)=NNCNT(67)
      K6(I)=NNCNT(68)
      K7(I)=NNCNT(72)
C      WRITE(9,50038) TNOW,WP,OMVF

```

```

50038 FORMAT(1X,'TNOW=',F10.0,2X,'WP=',F10.0,2X,'OMVF=',F10.0)
      P8(I)=WP
      P9(I)=OMVF
      P10(I)=OTVMIN
      P11(I)=OTVMAX
      OTVMIN=3.37E+38
      OTVMAX=-8.43E-37
      P12(I)=OMVMIN
      P13(I)=OMVMAX
      OMVMIN=3.37E+38
      OMVMAX=-8.43E-37
      RETURN
      END
      SUBROUTINE ALLOC(I,IFLAG)
      COMMON/SCOM1/ ATRIB(100),DD(100),DDL(100),DTNOW,II,MFA,MSTOP,NCLNR
      1,NCRDR,NPRNT,NNRUN,NNSE,NTAPE,SS(100),SSL(100),TNEXT,TNOW,XX(100)
      IFLAG=0
      GO TO (1,2),I
C     ALLOCATION RULE 1 - SEIZE MRMS AND OTV
      1 IF(NNRSC(3).LE.0.OR.NNRSC(5).LE.0) RETURN
      CALL SEIZE(3,1)
      CALL SEIZE(5,1)
      IFLAG=-1
      RETURN
C     ALLOCATION RULE 2 - SEIZE MRMS AND OMV
      2 IF(NNRSC(3).LE.0.OR.NNRSC(4).LE.0) RETURN
      CALL SEIZE(3,1)
      CALL SEIZE(4,1)
      IFLAG=-1
      RETURN
      END
      SUBROUTINE DTPUT
      COMMON/SCOM1/ ATRIB(100),DD(100),DDL(100),DTNOW,II,MFA,MSTOP,NCLNR
      1,NCRDR,NPRNT,NNRUN,NNSE,NTAPE,SS(100),SSL(100),TNEXT,TNOW,XX(100)
      COMMON/UCOM1/I1(30),I2(30),I3(30),I4(30),I5(30),I6(30),I7(30),
      1I8(30),J1(30),J2(30),J3(30),J4(30),J5(30),J6(30),J7(30),J8(30),
      2J9(30),K1(30),K2(30),K3(30),K4(30),K5(30),K6(30),K7(30),PB(30),
      3P9(30),P10(30),P11(30),P12(30),P13(30)
      N=NNCNT(1)
      WRITE(9,15)
      WRITE(9,16)
      16 FORMAT(/2X,'NOTE: ACTIVITY NO. SHOWN IN BRACKETS')
      WRITE(9,12)
      12 FORMAT(/2X,'BASE OPERATIONS:',/3X,'YEAR',3X,'LAUN',3X,'CARGO',
      12X,'LOGS',3X,'POTV',3X,'POMV',3X,'P/LS',3X,'TPLS',/1X,8(2X,
      2'(NO.)')/3X,'[ 1]',3X,'[11]',3X,'[ 7]',3X,'[ 4]',3X,'[ 2]',3X,
      3'[ 3]',3X,'[ 5]',3X,'[ 6]')
      WRITE(9,9)(I1(I),I2(I),I3(I),I4(I),I5(I),I6(I),I7(I),I8(I),I=0,N)
      WRITE(9,15)
      WRITE(9,13)
      13 FORMAT(/2X,'SPACE STATION OPERATIONS:',/3X,'YEAR',3X,'CARG',3X,
      1'LOG',4X,'ATT',4X,'OTVP',3X,'OMVP',3X,'LEO',4X,'GEO',4X,'PLAN',
      2/1X,9(2X,'(NO.)')/3X,'[ 1]',3X,'[20]',3X,'[24]',3X,'[25]',3X,
      3'[26]',3X,'[27]',3X,'[28]',3X,'[29]',3X,'[30]')
      WRITE(9,10)(J1(I),J2(I),J3(I),J4(I),J5(I),J6(I),J7(I),J8(I),J9(I),
      1I=0,N)
      WRITE(9,15)
      WRITE(9,14)
      14 FORMAT(/2X,'ORBITAL TRANSPORTATION OPERATIONS:',/3X,'YEAR',3X,
      1'LEO',4X,'LRES',3X,'GED',4X,'PLAN',3X,'GRES',3X,'TOTV'3X,

```

```

2'DTV PROP',2X,'DMV PROP'/1X,7(2X,'(NO.)'),2X,'(LBS.)',4X,
3'(LBS.)'/3X,'[.1]',3X,'[56]',3X,'[55]',3X,'[75]',3X,'[67]',3X,
4'[68]',3X,'[72]')
WRITE(9,11)(K1(I),K2(I),K3(I),K4(I),K5(I),K6(I),K7(I),P8(I),P9(I),
1I=0,N)
9 FORMAT(8I7)
10 FORMAT(9I7)
11 FORMAT(7I7,2F10.0)
15 FORMAT(////)
WRITE(9,15)
WRITE(9,17)
17 FORMAT(//2X,'DTV PROPELLANT FARM YEARLY SUMMARY:',/3X,'YEAR',3X,
1'MINIMUM LEVEL',4X,'MAXIMUM LEVEL')
WRITE(9,18)(K1(I),P10(I),P11(I),I=1,N)
18 FORMAT(I7,2X,F12.2,5X,F12.2)
WRITE(9,15)
WRITE(9,19)
19 FORMAT(//2X,'DMV PROPELLANT FARM YEARLY SUMMARY:',/3X,'YEAR',3X,
1'MINIMUM LEVEL',4X,'MAXIMUM LEVEL')
WRITE(9,18)(K1(I),P12(I),P13(I),I=1,N)
RETURN
END
SUBROUTINE INTLC
COMMON/SCOM1/ ATRIB(100),DD(100),DDL(100),DTNOW,II,MFA,MSTOP,NCLNR
1,NCRDR,NPRNT,NNRUN,NNSET,NTAPE,SS(100),SSL(100),TNEXT,TNOW,XX(100)
COMMON/UCOM1/I1(30),I2(30),I3(30),I4(30),I5(30),I6(30),I7(30),
1I8(30),J1(30),J2(30),J3(30),J4(30),J5(30),J6(30),J7(30),J8(30),
2J9(30),K1(30),K2(30),K3(30),K4(30),K5(30),K6(30),K7(30),P8(30),
3P9(30),P10(30),P11(30),P12(30),P13(30)
N=NNCNT(1)
WRITE(9,100)
100 FORMAT(' INPUT DESCRIPTION:')
WRITE(9,101) (XX(I),I=10,14)
101 FORMAT(2X,'RESERVICE TIME MULTIPLE FOR DMV/LED PAYLOADS,',
1 ' YEARS -',13X,F10.2,/,
2 2X,'RESERVICE TIME MULTIPLE FOR OTV/GEO PAYLOADS,',
3 ' YEARS -',13X,F10.2,/,
4 2X,'WEIGHT FOR DMV RESERVICE MODULE, LBS. -',27X,F10.2,/,
5 2X,'WEIGHT FOR OTV RESERVICE MODULE, LBS. -',27X,F10.2,/,
6 2X,'NUMBER OF PLANETARY PAYLOADS REQUIRED TO TRIGGER OTV',
7 ' PROPELLANT',/,7X,'FLIGHT -',53X,F10.2)
WRITE(9,102) (XX(I),I=15,19)
102 FORMAT(2X,'NUMBER OF GEO PAYLOADS REQUIRED TO TRIGGER OTV',
1 ' PROPELLANT FLIGHT -',F10.2,/,
2 2X,'REORDER POINT FOR DMV PROPELLANT STORED AT THE',
3 ' STATION, LBS. -',4X,F10.2,/,
4 2X,'REORDER POINT FOR OTV PROPELLANT STORED AT THE',
5 ' STATION, LBS. -',4X,F10.2,/,
6 2X,'MAXIMUM SHUTTLE CARGO WEIGHT, LBS. -',30X,F10.2,/,
7 2X,'MAXIMUM SHUTTLE CARGO BAY LENGTH, FT. -',27X,F10.2)
WRITE(9,103) (XX(I),I=20,24)
103 FORMAT(2X,'MAXIMUM NUMBER OF PAYLOADS MANIFESTED PER FLIGHT -',
1 16X,F10.2,/,
2 2X,'MAXIMUM OTV CARGO WEIGHT, LBS. -',35X,F10.2,/,
3 2X,'MAXIMUM TOTAL CARGO LENGTH ALLOWED FOR THE OTV',
4 ' FT. -',13X,F10.2,/,
5 2X,'MAXIMUM NUMBER OF PAYLOADS MANIFEST PER FLIGHT -',
6 18X,F10.2,/,
7 2X,'PROPELLANT REQUIRED FOR OTV FLIGHT TO GEO WITHOUT',
8 ' CARGO, LBS. -',3X,F10.2)

```

```

WRITE(9,104) (XX(I),I=25,29)
104 FORMAT(2X,'MAXIMUM OTV PROPELLANT REQUIRED FOR PLANETARY FLIGHT',
1      ' BASED ON',/,7X,'CAPACITY, LBS. -',45X,F10.2,/,
2      2X,'SCHEDULED LEADTIME FOR OTV PROPELLANT LAUNCH TO',
3      ' SUPPORT',/,7X,'RESERVICE, DAYS -',44X,F10.2,/,
4      2X,'AVERAGE OMV PROPELLANT DRAWDOWN FOR PROXIMITY',
5      ' OPERATIONS, LBS. -',2X,F10.2,/,
6      2X,'AVERAGE OMV PROPELLANT DRAWDOWN FOR LEO MISSIONS,',
7      ' LBS. -',10X,F10.2,/,
8      2X,'PAYLOAD TARE WEIGHT PENALTY FOR THE SHUTTLE, LBS/',
9      ' LINEAR FOOT',/,7X,'OF P/L -',53X,F10.2)
WRITE(9,105) (XX(I),I=30,31)
105 FORMAT(2X,'PROPELLANT AS A CARGO WEIGHT (MUST BE LESS THAN',
1      ' XX(18)), LBS. -',3X,F10.2,/,
2      2X,'MAXIMUM NUMBER OF OTV PROPELLANT DELIVERIES TO BE',
3      ' AUTO-',/,7X,'MATICALLY PRESCHEDULED AT ONE TIME -',
4      25X,F10.2,///)
RETURN
END

```

1. Report No. NASA TM-100481	2. Government Accession No.	3. Recipient's Catalog No.	
4. Title and Subtitle A Space Transportation System Operations Model		5. Report Date December 1987	6. Performing Organization Code
		8. Performing Organization Report No.	
7. Author(s) W. Douglas Morris and Nancy H. White		10. Work Unit No. 506-49-11-03	
9. Performing Organization Name and Address NASA Langley Research Center Hampton, VA 23665-5225		11. Contract or Grant No.	
		13. Type of Report and Period Covered Technical Memorandum	
12. Sponsoring Agency Name and Address National Aeronautics and Space Administration Washington, DC 20546		14. Sponsoring Agency Code	
		15. Supplementary Notes	
16. Abstract This paper presents a description of a computer program which allows assessment of the operational support requirements of space transportation systems functioning in both a ground- and space-based environment. The scenario depicted provides for the delivery of payloads from Earth to a Space Station and beyond using upper stages based at the Station. Model results are scenario dependent and rely on the input definitions of delivery requirements, task times, and available resources. Output is in terms of flight rate capabilities, resource requirements, and facility utilization. A general program description, program listing, input requirements, and sample output are included.			
17. Key Words (Suggested by Author(s)) Space Transportation Logistics Computer Program Operations		18. Distribution Statement Unclassified - Unlimited Subject Category - 16	
19. Security Classif. (of this report) Unclassified	20. Security Classif. (of this page) Unclassified	21. No. of Pages 64	22. Price A04