

N O T I C E

THIS DOCUMENT HAS BEEN REPRODUCED FROM
MICROFICHE. ALTHOUGH IT IS RECOGNIZED THAT
CERTAIN PORTIONS ARE ILLEGIBLE, IT IS BEING RELEASED
IN THE INTEREST OF MAKING AVAILABLE AS MUCH
INFORMATION AS POSSIBLE

LEGIBILITY NOTICE

A major purpose of the Technical Information Center is to provide the broadest dissemination possible of information contained in DOE's Research and Development Reports to business, industry, the academic community, and federal, state and local governments.

Although a small portion of this report is not reproducible, it is being made available to expedite the availability of information on the research discussed herein.

Integration of Symbolic and Algorithmic Hardware and Software for the Automation of Space Station Subsystems

Hugh Gregg, Lawrence Livermore National Laboratory
P.O. Box 808, L-310, Livermore, CA 94550
Kathleen Healey, Johnson Space Center
Houston, TX
Edmund Hack, Lockheed EMSC
Houston, TX

Carla Wong, Systems Autonomy Demonstration Project Office
NASA Ames Research Center
M/S 244-18, Moffett Field, CA 94035

UCRL--97570

Abstract

DE88 002386

Traditional expert systems, such as diagnostic and training systems, interact with users only through a keyboard and screen, and are usually symbolic in nature. Expert systems that require access to data bases, complex simulations and real-time instrumentation have both symbolic as well as algorithmic computing needs. These needs could both be met using a general purpose workstation running both symbolic and algorithmic code, or separate, specialized computers networked together. The latter approach was chosen to implement TEXSYS, the thermal expert system, developed by NASA Ames Research Center in conjunction with Johnson Space Center to demonstrate the ability of an expert system to autonomously control the thermal control system of the space station. TEXSYS has been implemented on a Symbolics workstation, and will be linked to a microVAX computer that will control a thermal test bed. This paper will explore the integration options, and present several possible solutions.

Introduction

As part of NASA's Systems Autonomy Demonstration Project (SADP), a series of four demonstrations will be conducted to show the capability of increasingly complex expert systems applied to space station subsystems needs. The first of these demonstrations, the thermal expert system (TEXSYS), is being developed to show the use of artificial intelligence technology in the operation and management of the space station thermal control system. This demonstration is a joint project of the Ames Research Center (ARC) and Johnson Space Center (JSC) under the direction of the Systems Autonomy Demonstration Project Office at ARC. TEXSYS [2] will be used to monitor, control, diagnose, and reconfigure a large space station prototype thermal test bed (TTB) at JSC. A small thermal test bed will be used at ARC during the development and testing of TEXSYS prior to integration with the large TTB system at JSC.

MASTER

The thermal expert system being developed at ARC will consist of an expert system (TEXSYS) and an intelligent human interface (HITEX). TEXSYS contains the thermal domain knowledge provided by the Crew and Thermal division of JSC, and will be used for autonomous control, diagnosis and reconfiguration. HITEX is the "human interface" to the thermal expert system, providing explanation facilities and system status graphics. This latter system will be developed by the Human Factors Division at ARC to demonstrate an ergonomic interface to the TTb, such as would be required by the thermal engineer for use on the space station. The JSC test bed will be controlled by the TEXSYS Data Acquisition System (TDAS [6]).

The thermal test bed at ARC is small version of the two-phase ammonia thermal bus prototype at JSC. The ARC TTb will be controlled by a conventional computer control system, and data collection and communications software will be developed by Lawrence Livermore National Laboratory. This paper describes the approach taken for integration of both the symbolic and algorithmic hardware and software used for the Ames thermal brassboard portion of this project. It is expected that this approach and its extensions will be compatible with and meet the requirements of the TEXSYS system when integrated into the JSC thermal test bed facility as described previously [6].

Identifying Algorithmic vs. Symbolic Processes

The three major sections of this project are TEXSYS, HITEX and the TTb control functions. All three of these processes could conceivably be executed on one computer, but overall system performance would not be adequate. It was decided that each of these functions would be handled by separate computers integrated into one larger system. This approach allows the use of optimized hardware for each subsystem, and provides the capability for the eventual integration of cooperating expert systems, such as the 1990 SADP demonstration for cooperating expert systems involving the management of both the thermal and power systems.

Separating algorithmic and symbolic processes to different computers has been shown previously to be very effective. The TQMS'TUNE expert system developed at Lawrence Livermore National Laboratory [1,4-5,7-8] runs on a Xerox LISP workstation, and communicates with a conventional minicomputer (DEC PDP-11/23) that operates the triple quadrupole mass spectrometer (TQMS). The "tweaker" (a process of adjusting an instrumental parameter for maximum signal) was originally implemented, in LISP, on the Xerox workstation. When the tweaker was recoded in FORTRAN and ported to the control computer, the time required to tune the instrument (the goal of TQMS'TUNE) was reduced by a factor of 6. This time difference reflected the symbolic or heuristic portions of the expert system's ability to perform better with high level information rather than large amounts of low level data.

These concepts are being applied to the TEXSYS system. For example, the control and collection of data from the thermal test bed is an algorithmic process. These processes, as well as data reduction, storage and display are well understood and are being coded in standard algorithmic languages, such as FORTRAN and C. A conventional microVAX II algorithmic processor was chosen for this application.

The heuristics of control, fault diagnosis, and reconfiguration are represented as symbolic processes. These processes comprise the heuristic part of TEXSYS and were designed using the Knowledge Engineering Environment, KEE (Intellicorp) and a NASA-developed model tool kit (MTK) for model-based reasoning on a Symbolics workstation [3]. The size, complexity, and symbolic nature of TEXSYS require that it remain on a specialized Symbolics LISP processor but must be able to freely access high level information abstracted from all the data being acquired from the microVAX.

The choice of algorithmic vs. symbolic workstation is less clear for HITEX, for it has simultaneous symbolic and algorithmic display needs. Therefore, a general purpose workstation (Sun Microsystems) able to handle both expert system development environments (i.e. KEE) and display process control graphics, will be utilized.

Communications Requirements

Each of the three systems briefly described above must be able to communicate with the others. Both the expert system TEXSYS and the human interface HITEX require current thermal test bed information, and both must be able to control the TTB. Each expert must be able to interact with the other, i.e. HITEX may be requested to explain a TEXSYS action, or HITEX (or the human operator) may need to instruct TEXSYS to change operational modes. Figure 1 shows the logical communications links required to implement this system and a few of the Ames TTB hardware

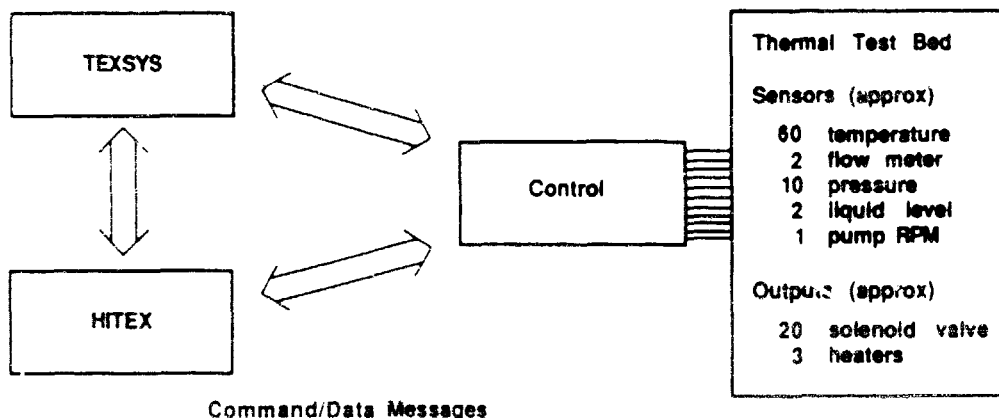

Command/Data Messages

Figure 1

parameters that must be controlled. The same types of parameters must be controlled on the JSC prototype TTB with similar data rates, but there are considerably more parameters on the JSC test bed.

The control computer will be acquiring sensor input at a rate of once per second. The volume of data recorded make it impractical for TEXSYS and HITEX to evaluate the raw data for every decision. A second function of the control computer, therefore, is to extract meaningful information from the collected data. Examples of this data reduction include calculating the rate of change for a temperature sensor and checking all sensors for under or over limit conditions. With both the raw and processed data available, the expert system and the human interface can utilize whichever data is appropriate for a given rule or time constraint. A third function of the control computer is to moderate conflicting control commands from the two higher level systems.

Both TEXSYS and HITEX will need to be able to control the TTB. Control functions include opening and closing valves, turning pumps on and off, changing set points, alarms and limits and initializing the entire system. Although it is possible to have both systems control the TTB at the same time, the control software will allow only one system to issue control commands. This allows the expert system, TEXSYS, to be in control, and know the state of the TTB. If the HITEX system needs to issue a command, it must request that TEXSYS issue that command. If for some reason TEXSYS is unable to control the test bed (i.e. the computer crashed), the data acquisition computer will detect the lack of activity, and allow HITEX to control the TTB.

Communications Hardware

There are several possible hardware communications schemes, two of which are shown in Figure 2. In point-to-point topology, each process would have a dedicated link for every communication

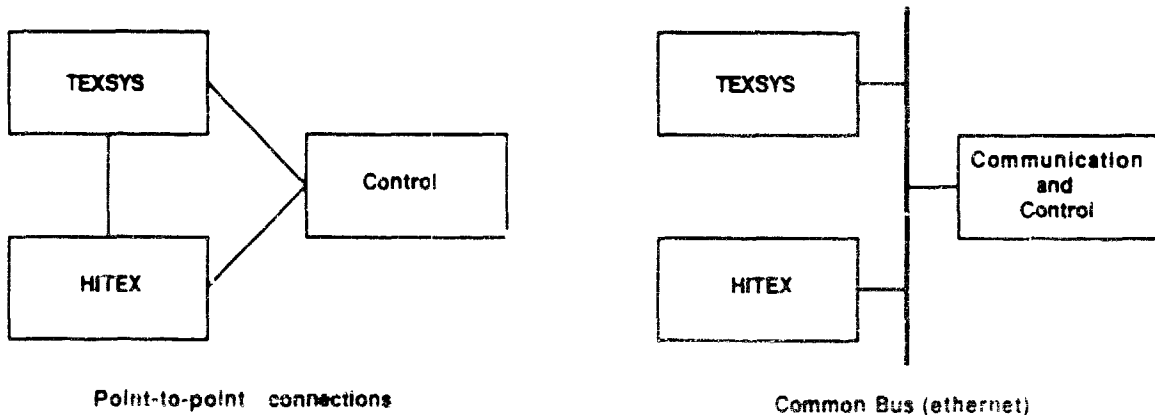

Figure 2

channel. This is the simplest mechanism, but when the system grows beyond a few nodes, it becomes unmanageable. A bus oriented topology offers an easy growth path (for adding more systems) and often allows for logical point-to-point links. However, as a general purpose shared resource, a common bus may become a bottleneck and reduce overall system performance. Based on these considerations, a combination of a common bus and a point-to-point link was adopted for the TEXSYS project.

The choice of the communication scheme implemented is dependent on the required throughput of the communication channel. The throughput includes not only the bandwidth of the communications hardware, but also includes the software overhead associated with accessing that device. Each of the processors selected for this project are able to use ethernet as a communications bus. The protocol used to send packets over the ethernet will be either TCP/IP or DECNET, depending on the throughput of each package.

TEXSYS may require large quantities of information from the data acquisition/control computer. A specialized point-to-point link between those two computers will be used. This "bus-link" (made by Flavors Technology, Inc.) allows the Symbolics computer direct access to a portion of the microVAX memory. By copying the TTb parameters into a specified portion of the microVAX memory, TEXSYS is able to quickly retrieve any required datum. Control commands and communications with HITEK will use ethernet to provide consistent interface among all three systems. The use of both ethernet and the bus-link product give TEXSYS the best of both systems: a point-to-point link for accessing large quantities of data, and a common bus to provide an interface to other systems.

Communications Software

Expert systems running under the KEE shell are able to take advantage of a KEE feature, active values. When a rule (or LISP code) either gets or puts the value of a slot (e.g. reads or writes the value of a variable), the active value method (e.g. subroutine or function) is invoked if it exists. This active value method may execute any code, and the the value it returns (for a GET.VALUE function of a slot) is used by the rule that requested the value. Both TEXSYS and HITEK use this mechanism to retrieve TTb parameters. For example, if a TEXSYS rule premise is based on the pressure before the condenser (eq. 1), the rule interpreter retrieves the value of the transducer (eq. 2) and the active value methods fires (eq. 3). This LISP code either looks up the value in the shared memory provided by the Bus-Link, or uses ethernet to request the value from the control computer. The active value method then returns a value, P, to the slot (eq. 4), and the rule uses the returned value for its comparison (eq. 5). Values may be set in the same way.

```

if Pressure_before_condenser > limit then conclusion (1)
GET.VALUE Pressure_before_condenser (2)
AVGET method (LISP code, returns P) (3)
Pressure_before_condenser = P (4)
if P > limit then conclusion (5)

```

The use of active values allows for transparent use of the network to obtain the needed information, and can be used for all routine messages and data between the human interface and expert system and the control computer. This method was used for the TQMSTONE system described earlier. It should be noted that the active value mechanism imposes a master/slave relationship upon the systems.

Both the human interface and the expert system act as a communication master (requestor), sending or receiving data as necessary to derive explanations of to test the rules. The control computer, however, must be able to quickly respond, at any time, to requests from one or more external systems. As a slave process (data server), the control computer cannot send any data unless requested by the master process. In the event of an alarm condition (i.e. sensor out of limit), the control computer must wait until the expert system requests some data, and then may send a warning flag indicating a potential problem. The expert system may then request more information about the warning. Since the expert system is constantly requesting information and data from the control computer, the warning condition will be recognized in short order. This configuration assumes that the delay in the notification of a warning condition is minimal when compared to the overall response time required to service the alarm condition by the expert system.

A second method of communicating between the expert system and the control computer is to have the expert system explicitly request information from the communications interface. This allows the expert system complete control over the knowledge base, and all information in it will be consistent. A separate process can receive data and alarms from the control computer, and the diagnostic portion of the system initiated if an alarm occurs.

Communications Subsystem

The active value mechanism works well for communications between the expert system and the control computer, but for lengthy, information messages (i.e. TEXSYS explaining to HITEX why certain actions were taken), a different approach should be taken. Two possible solutions are a direct logical connection between TEXSYS and HITEX over ethernet, or a microVAX buffered communications system between the human interface and the expert system. Both configurations are under consideration.

Ethernet is used as the common communications bus; a communications interface, implemented on the microVAX, is used as

the software communications bus. Figure 3 is a block diagram of this interface software. The communications interface acts as a central clearing agent for informational messages, warning messages and commands. Information messages, from whatever source, are saved until requested, while warning messages and commands are immediately sent to the target processes. In this way, only urgent messages (warnings and commands) interrupt the expert system, and routine informational messages are retrieved only when the expert system needs that information.

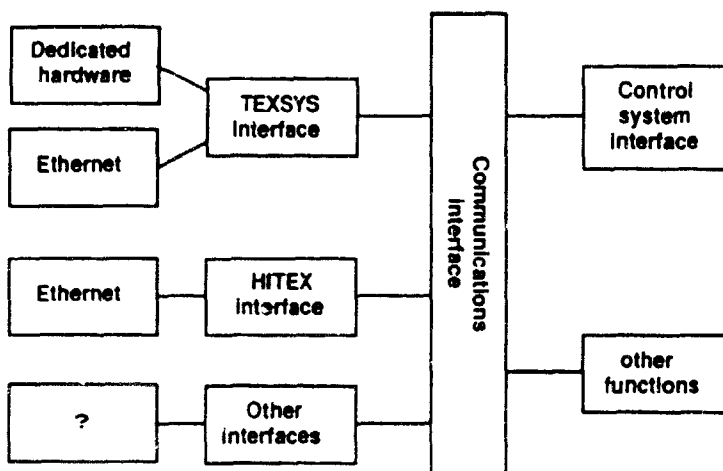

Figure 3

All systems interfaced to this message router have access to the TTb parameters and status (via the control system interface). Daemon processes analyze the collected data ("other functions" in Figure 3) and issue warning messages when needed (i.e. if a pressure is rising too rapidly or is out of acceptable limits). In theory, commands to control the TTb may be given by any connected process, but command conflicts would be a major problem, and would best be handled by the expert system. For this reason, it is expected that all commands will originate from TEXSYS, and HITEX will request TEXSYS to issue commands as necessary.

The dedicated TEXSYS to control computer link is essentially a virtual memory device. This link is in addition to the ethernet link, and bypasses much of the software overhead associated with the ethernet link. TEXSYS could operate without this link, but its use allows a significant decrease in TEXSYS access time to TTb parameters.

Conclusions

The division of processes among algorithmic and symbolic processors is usually straight forward. Accessing data bases or real-time instrumentation are algorithmic processes, while expert systems are generally symbolic in nature. To effectively integrate these these processes into a composite system requires an effective communications scheme. For small systems, point-to-

point links are simple and sufficient; however, for large systems, bus topology and a message server are usually required.

Acknowledgements

Work performed under the auspices of the U.S. Department of Energy by the Lawrence Livermore National Laboratory under contract number W-7405-ENG-48. The support of the the Systems Autonomy Demonstration Project Office at NASA Ames Research Center (proposal L-792) is gratefully acknowledged.

References

- [1] Brand, H.R. and Wong, C.M., "Application of Knowledge based Systems Technology to Triple Quadrupole Mass Spectrometry", Proceedings of American Association of Artificial Intelligence (AAAI-86), Vol. 2 (1986) 812-819.
- [2] Bull, J.S., Brown, R., Friedland, P., Wong, C.M., Bates, W., Healey, K.J. and Marshall, P., "NASA System Autonomy Demonstration Project: Development of Space Station Automation Technology", 2nd AIAA/NASA/USAF Symposium on Automation, Robotics and Advanced Computing for the National Space Program; Arlington, VA, March 9-11, 1987.
- [3] Erickson, W.K. and Schwartz, M.R., "MTK: An AI Tool For Model-Based Reasoning", 3rd Annual Conference on Artificial Intelligence for Space Applications, NASA/MSFC, Huntsville, AL, Nov. 2-3, 1987.
- [4] Gregg, H.R., Brand, H.R. and Wong, C.M., "A Knowledge based System for Tuning MS/MS Instruments in Various Operational Modes", 34th Annual Conference on Mass Spectrometry and Allied Topics, Cincinnati, OH, June 8-13, 1986.
- [5] Gregg, H.R. and Wong, C.M., "TQMSTUNE: The Rules", 35th Annual Conference on Mass Spectrometry and Allied Topics, Denver, CO, May 24-29, 1987.
- [6] Healey, K. and Hack, E., "TDAS: A Thermal Expert System Data Acquisition System", SOAR-87: 1st Annual Workshop on Space Operation, Automation and Robotics; NASA/USAF/Univ Houston, Houston, TX, August 5-7, 1987.
- [7] Wong, C.M., Crawford, R.W., Kunz, J.C. and Kehler, T.P., "Applications of Artificial Intelligence to Triple Quadrupole Mass Spectrometry", IEEE Transactions on Nuclear Science, Vol NS-31, 1, (1984), 804-810.
- [8] Wong, C.M., Lanning, S.M., Crawford, R.W. and Brand, H.R., "Application of Artificial Intelligence Programming Techniques to the Development of an Expert System for Tuning a Triple Quadrupole Mass Spectrometer", 32nd Annual Conference on Mass Spectrometry and Allied Topics, May 1984.