

FUTURE DIRECTIONS IN FIBER OPTICS FOR CONTROLS

Future program directions are outlined. We are attempting to serve as a focus for developing a users' set of standard specifications for fiber-optic components to be employed in aircraft control systems, as well as to support the development of these components.

FUTURE DIRECTIONS IN FIBER OPTICS FOR CONTROLS

- **CONTINUE EFFORTS AIMED AT ACHIEVING FOCSI OBJECTIVES**
- **CONTINUE DEVELOPMENT OF NOVEL FIBER-OPTIC SENSOR CONCEPTS**
- **ENGINE TEST PROTOTYPES OF PROMISING FIBER-OPTIC SENSOR SYSTEMS**
- **STUDY INNOVATIVE APPROACHES TO ACTUATION DEVICE DESIGN**
- **SERVE AS FOCUS FOR ACHIEVING CONSENSUS ON FIBER-OPTIC COMPONENT SPECIFICATIONS FOR AIRCRAFT**

PROPULSION CONTROL ISSUES

The demand for increased functionality for future aircraft and the desire to optimize aircraft and propulsion systems as an integrated entity has led to a large increase in the physical complexity of the aircraft/propulsion systems. The new functionalities include vertical and short takeoff capability coupled with high-speed cruise. To achieve these capabilities, special purpose aircraft are being designed with a high degree of dynamic coupling between aircraft and propulsion systems. This is a dramatic departure from traditional aircraft design where such coupling was minimized. The effect of large dynamic coupling is to increase pilot work load. Advanced controls can alleviate the problem of pilot work load and allow optimal aircraft performance to be achieved; however, this necessitates that a unified or integrated approach to aircraft flight controls and propulsion control be evolved. Control weight as a percentage of propulsion system weight is significant in spite of gains made by conversion to digital systems. This area, however, is considered to be a design issue best approached by industry.

PROPULSION CONTROL ISSUES

- **INCREASED AIRCRAFT AND PROPULSION SYSTEM COMPLEXITY**
- **INCREASED DYNAMIC COUPLING BETWEEN AIRCRAFT AND PROPULSION SYSTEM**
- **CONTROL SYSTEMS WEIGHT**

TRENDS IN CONTROL COMPLEXITY OF AIRCRAFT TURBINE ENGINES

Airbreathing engine complexity is reflected by the number of primary control variables managed for a given engine. The trend has shown a steady increase in controlled variables over the years. With this trend has come the use of full-authority digital electronic controllers.

TRENDS IN CONTROL COMPLEXITY OF AIRCRAFT TURBINE ENGINES

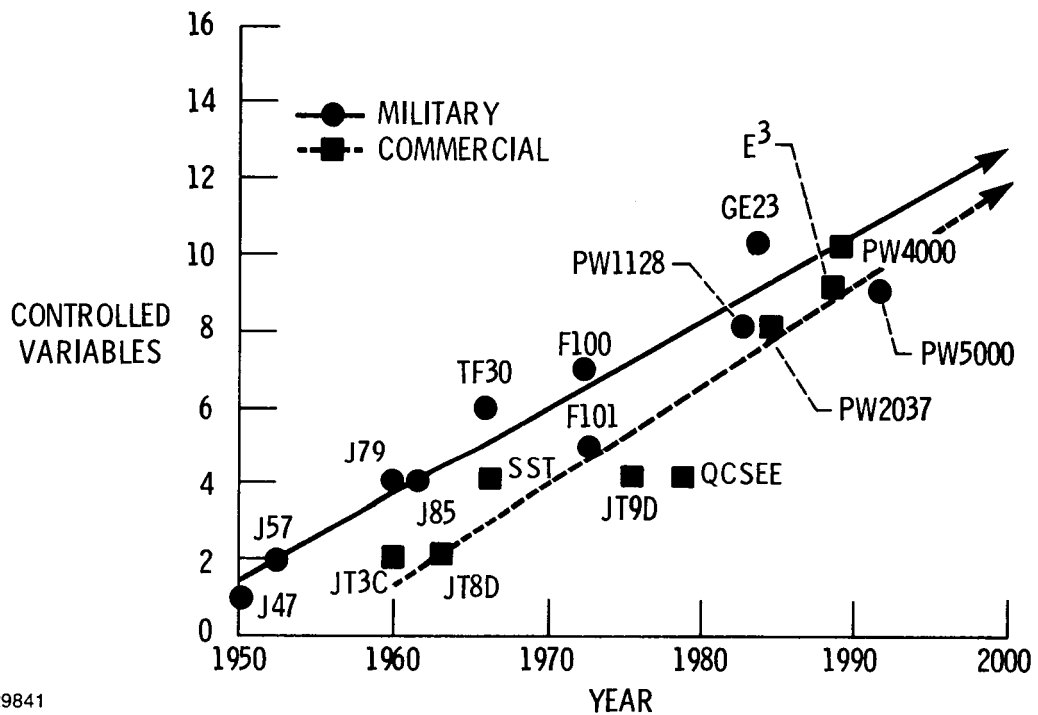

CD-87-29841

ORIGINAL PAGE IS
OF POOR QUALITY.

DYNAMICALLY COUPLED AIRCRAFT

Typical of aircraft with significant dynamic coupling are the following: supersonic short takeoff and vertical landing aircraft (SSTOVL), advanced high speed rotorcraft, and hypersonic aircraft where engine air capture and aircraft pitch control are tightly coupled. The vertical lift aircraft flight control at low forward speed and through transition to horizontal flight are typically dominated by propulsion control considerations. These aspects provide strong motivation for research in the area of flight/propulsion control integration.

DYNAMICALLY COUPLED AIRCRAFT



CD-87-29842

CURRENT PROPULSION CONTROLS RESEARCH

Current activities of the NASA Lewis controls research program are indicated in this figure. The hypersonic propulsion control work includes engine dynamic modelling, propulsion control, and control instrumentation. Dynamic models of inlet unstart and controls for ram/scram jet operation are being developed. The Reconfigurable Control effort seeks to create an expert system intelligence which can, in real time, "redesign" a control system to account for significant changes in aircraft or engine behavior. The Real-Time Identification effort determines model structure and estimates model parameters in a noisy environment in real time. Efforts in control networking aim to develop high-performance communications systems tailored to distributed, integrated control systems. Sensor Failure Accommodation will be detailed in the following figures.

CURRENT PROPULSION CONTROLS RESEARCH

- **HYPERSONIC PROPULSION CONTROL**
- **RECONFIGURABLE CONTROL**
- **REAL-TIME SYSTEM IDENTIFICATION**
- **CONTROLS NETWORKING**
- **SENSOR FAILURE DETECTION AND ACCOMMODATION**

SENSOR FAILURE DETECTION AND ACCOMMODATION
- REPLACE HARDWARE REDUNDANCY WITH ANALYTICAL REDUNDANCY -

The Sensor Failure Accommodation Program strives to attain control system reliability through the application of analytical redundancy instead of hardware redundancy. This approach uses redundant sensor information and reference models of the engine to detect sensor failures and to generate accurate estimates which replace failed sensor information in the controller.

SENSOR FAILURE DETECTION & ACCOMMODATION

PRINCIPLE—REPLACE HARDWARE REDUNDANCY WITH ANALYTICAL REDUNDANCY

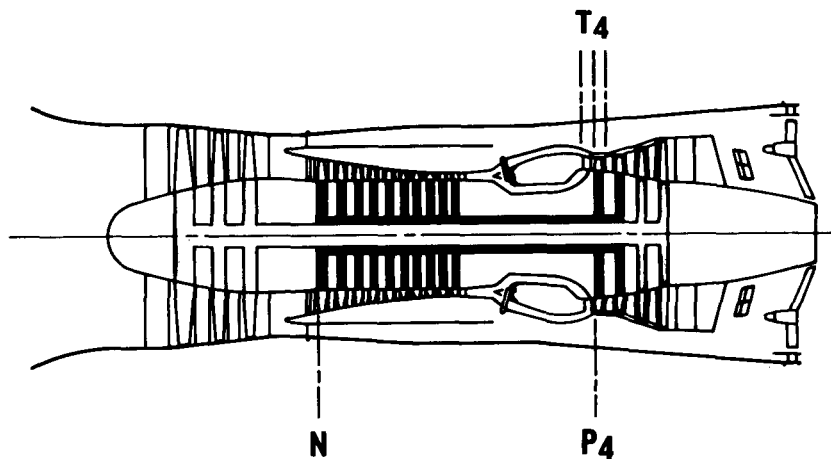

HARDWARE REDUNDANCY
● 3 SENSORS → T_4
● MAJORITY VOTE DETECTS FAILURE

ANALYTICAL REDUNDANCY
● 1 SENSOR → T_4
● REFERENCE MODEL DETECTS FAILURE
● REDUNDANT INFORMATION (P_4, N) GENERATES T_4 , EST

CD-87-29844

SENSOR FAILURE ACCOMODATION
- CONCEPT -

The sensor failure accommodation logic uses sensed signals from the engine and actuators together with analytical models of the engine to create (Kalman filter based) estimates of the engine parameters. These estimates are used by the multi-variable control as representing the actual engine variables. Failed sensors are detected by "hypothesis testing." A series of hypothesis filters are used; each filter uses all available signals but one. Likelihood statistics are generated and compared to detect the failed sensor(s). The failed sensors are then removed from the calculation of the estimates.

SENSOR FAILURE ACCOMMODATION
- CONCEPT -

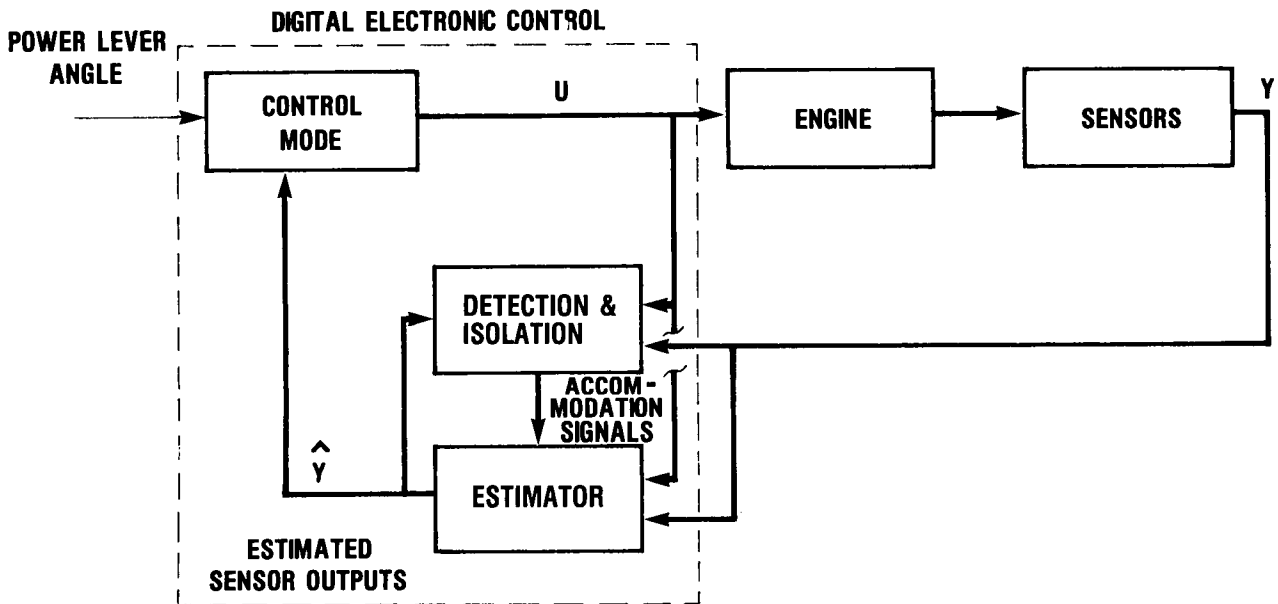

CD-87-29845

SENSOR FAILURE ACCOMODATION
- HARDWARE IMPLEMENTATION -

The sensor failure accomodation algorithm is implemented in a triple microprocessor based control system. The computers calculate (1) the multivariable control laws, (2) the detection and accomodation logic, and (3) the isolation logic to determine which sensors have failed. The processors are Intel 80186/8087 based hardware which allow a 40-msec update time while processing the algorithms in FORTRAN.

SENSOR FAILURE ACCOMMODATION
— **HARDWARE IMPLEMENTATION** —

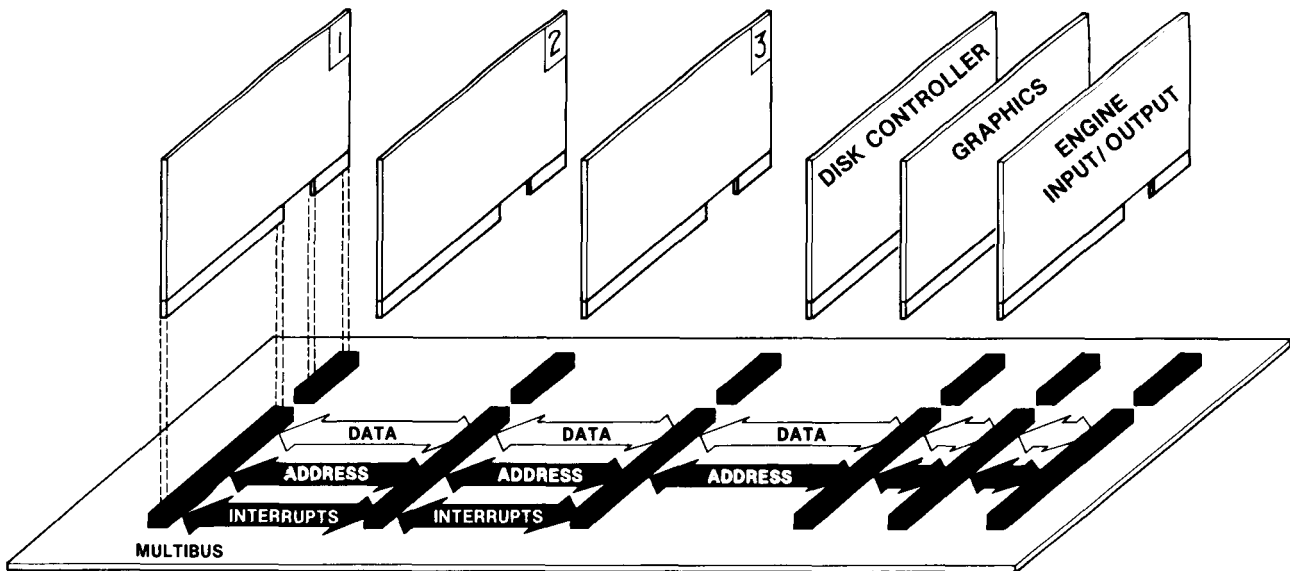

CD-87-29846

ORIGINAL PAGE IS
OF POOR QUALITY.

SENSOR FAILURE ACCOMODATION
- VALIDATION TESTING -

To validate the analytical formulation and practical implementation of the sensor failure algorithm, full-scale tests were performed with the P&W F-100 engine. The tests were conducted over a wide range of altitude/Mach number conditions in the Lewis Research Center Propulsion Systems Laboratory.

SENSOR FAILURE ACCOMMODATION
— VALIDATION TESTING —

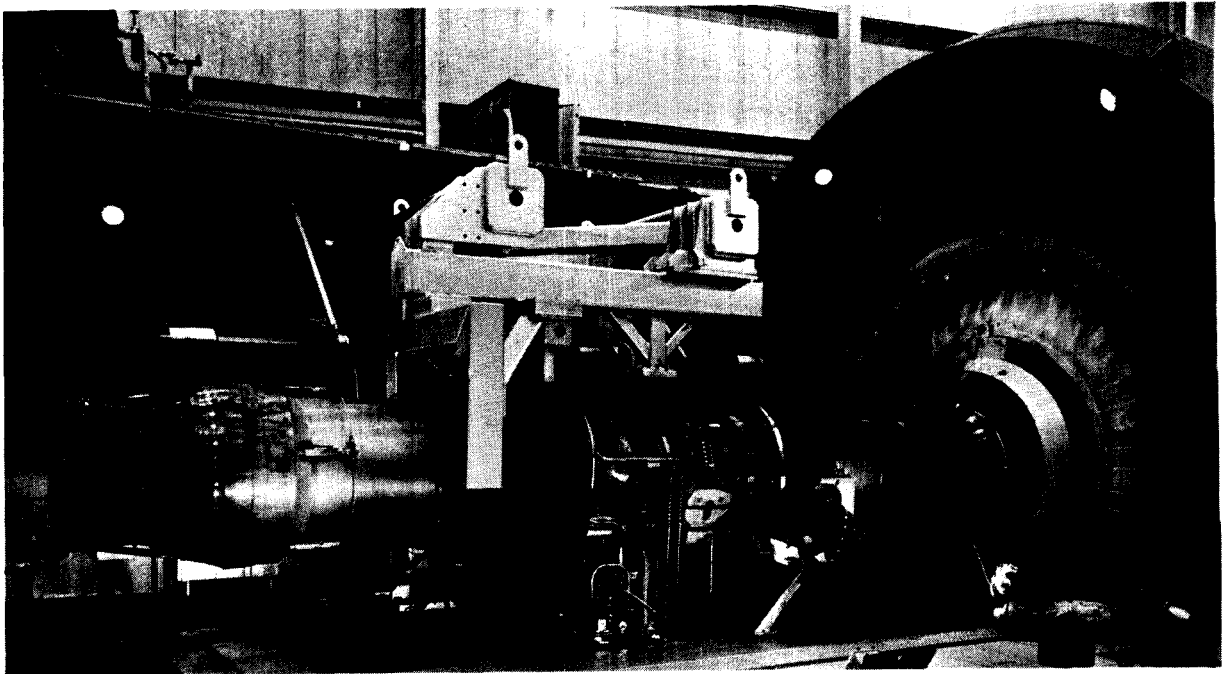

CD-87-29847

SENSOR FAILURE ACCOMMODATION
- F-100 ENGINE DRIFT FAILURE ON NOZZLE PRESSURE -

This figure shows actual engine performance in response to an imposed drift failure in the nozzle pressure sensor signal. The major events are:

- A - Nozzle pressure drift failure begins (1 psi/sec).
- B - Actual nozzle pressure decreases as control reacts to sensor failure.
- C - Sensor failure detected.
- D - Performance recovers after failure accommodation.
- E - Without sensor failure accommodation engine shutoff occurs.

Such small drift failures are very difficult to detect and thus the time for detection is not immediate. It can be seen, however, that the actual engine thrust loss is quite small.

SENSOR FAILURE ACCOMMODATION
F-100 ENGINE DRIFT FAILURE ON NOZZLE PRESSURE

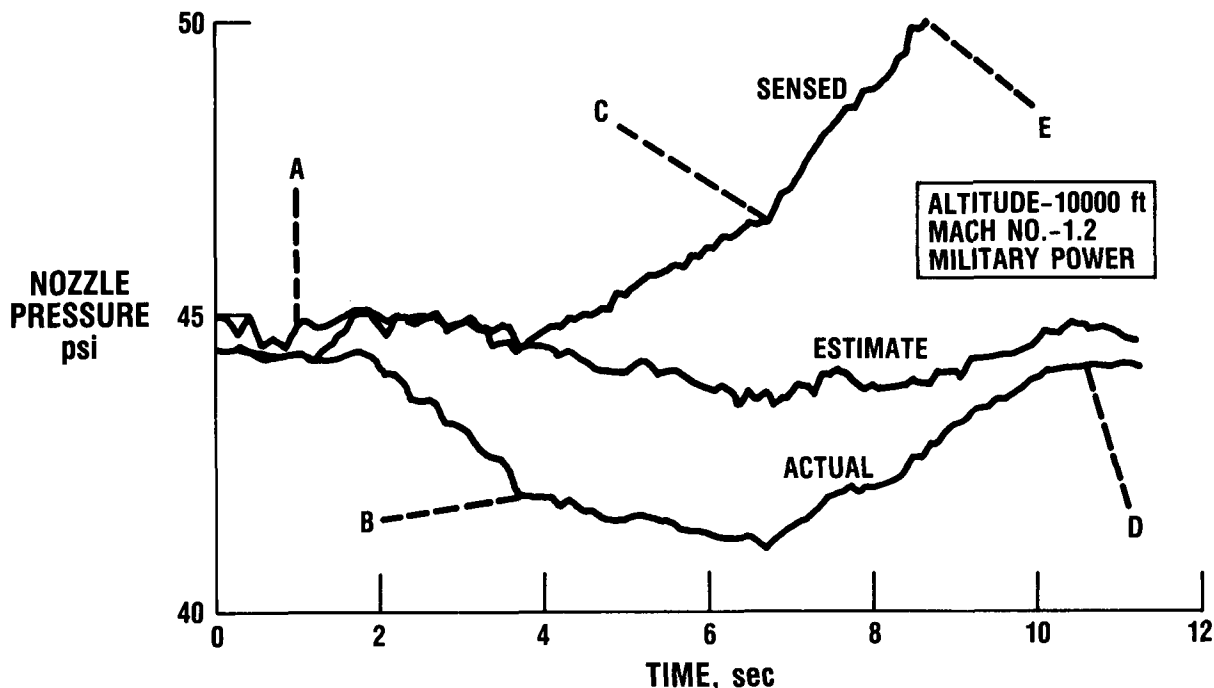

CD-87-29848

ENGINE PULSE RESPONSE
- ALL SENSES FAILED -

Under the condition when all engine control sensors failed, the controller correctly detected each failure and accommodated all failures by using the computed estimates for all the signals. While in this condition the engine was smoothly accelerated and decelerated as shown in the figure.

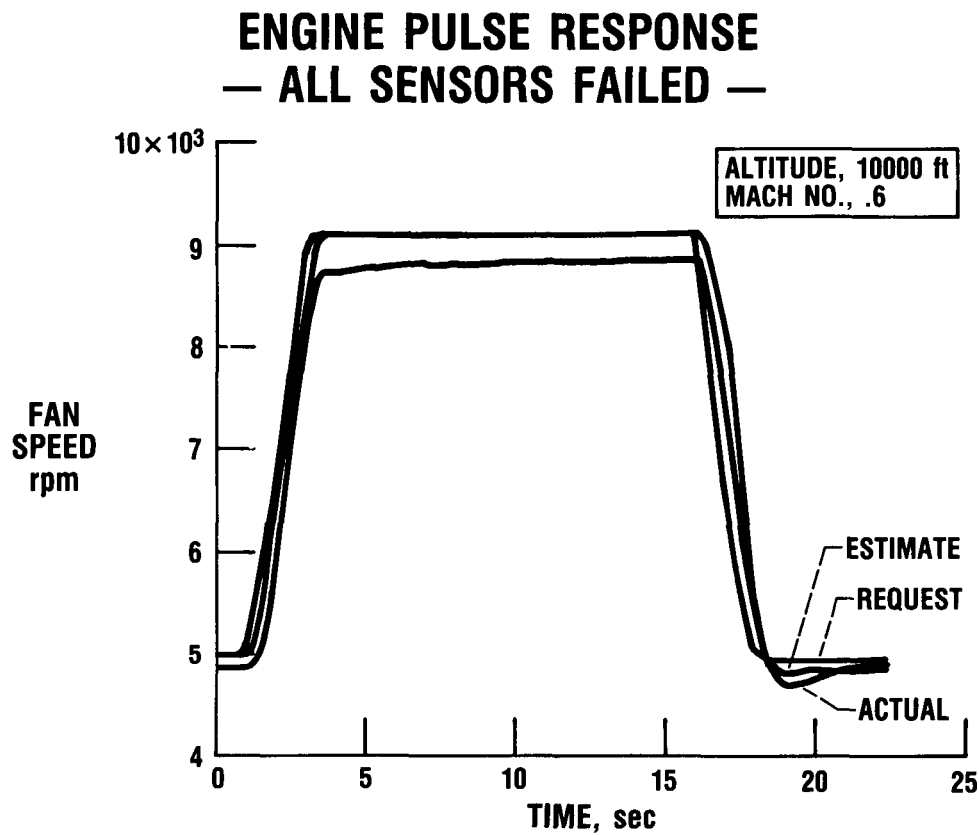

CD-87-29849

F-100 ENGINE TEST RESULTS

This chart summarizes the results of the sensor failure accommodation testing on the P&W F-100 engine. Demonstrated capabilities include the detection, isolation and accommodation of drift, in-range step, noise, and large-scale "hard" failures. Also demonstrated was the capability to detect sequential sensor failures as well as simultaneous failures. Excellent post-failure control performance was demonstrated including full-range operation with single sensor failure.

F-100 ENGINE TEST RESULTS

LEWIS ALTITUDE TEST FACILITY

- **HIGH-PERFORMANCE FAILURE DETECTION**
 - **120 DIFFERENT FAILURE SCENARIOS**
 - **11 ENGINE OPERATING CONDITIONS**
 - BOTH SUBSONIC AND SUPERSONIC CONDITIONS**
- **GOOD POST-FAILURE ACCOMMODATION PERFORMANCE**
 - **NO SIGNIFICANT LOSS OF PERFORMANCE**
 - **POWER TRANSIENTS WITH ACCOMMODATED FAILURES**
- **SEQUENTIAL FAILURE DETECTION AND ACCOMMODATION**
- **SIMULTANEOUS FAILURE DETECTION AND ACCOMMODATION**
- **ENGINE CONTROL WITH ALL SENSORS FAILED**

CD-87-29850

NEW THRUSTS IN PROPULSION CONTROL

The new thrusts in propulsion control at NASA Lewis are focussed on the areas of Supersonic V/STOL Integrated Control and Intelligent System Control.

NEW THRUSTS IN PROPULSION CONTROL

- **SUPERSONIC V/STOL INTEGRATED CONTROL**
- **INTELLIGENT SYSTEM CONTROL**

CD-87-29851

NASA SUPERSONIC STOVL INTEGRATED CONTROLS PROGRAM

The supersonic STOVL aircraft typifies the trend toward complex aircraft with large dynamic coupling between the aircraft and propulsion system. The NASA Lewis and NASA Ames program will develop advanced integrated controls methodologies and designs for this application. Current plans focus on the F-16 aircraft and the F-110 engine with vectorable nozzles and ejector thrust augmentation. The integration problem is to evolve controls designs and methodologies which integrate subsystem controls in a manner to achieve optimal aircraft performance. Nonlinear simulation models of both the aircraft and the propulsion system will be created. Linear controls models will be abstracted from these to be used as a basis for control design. Validation tests at NASA Lewis will incorporate a piloted simulator and actual engine/ejector firing along with a simulated aircraft to evaluate developed control laws. Final validation will be done with the NASA Ames Vertical Motion Simulator.

NASA SUPERSONIC STOVL INTEGRATED CONTROLS PROGRAM

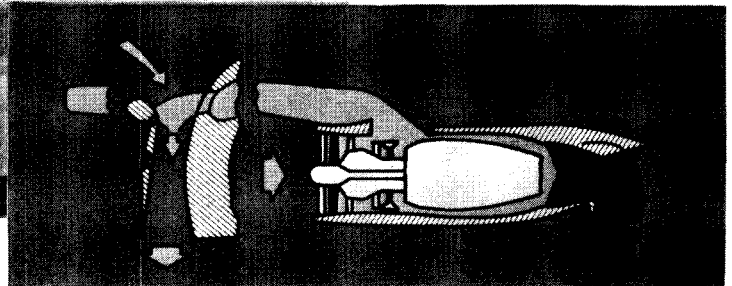

ORIGINAL PAGE IS
OF POOR QUALITY

PROPULSION SYSTEM INTELLIGENCE

This diagram indicates an expansion of the traditional control function into a broad system intelligence. This will be initially applied to Reusable Space Propulsion Systems. Artificial intelligence concepts will likely be used for the highlighted functions. The inner control loop will be designed with life extending methodologies (yet to be developed). An onboard diagnostic/prognostic expert system will identify impending hardware failures using information from a component condition monitor, an engine dynamics monitor, and performance information. A high level coordinator will determine the required remedial action; for example, change control request or if necessary a control adapter will reconfigure (redesign) the control in flight. This research is expected to greatly enhance vehicle and propulsion performance and to substantially improve life, reliability, and maintainability.

PROPULSION SYSTEM INTELLIGENCE

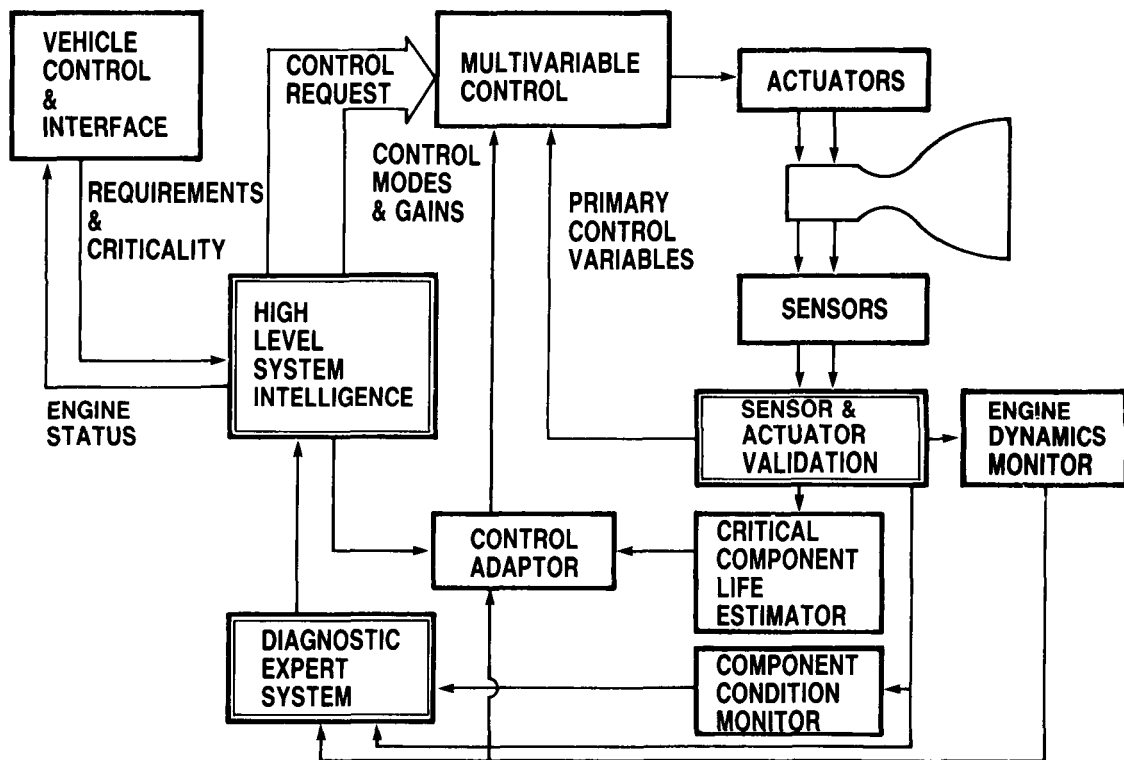

CD-87-29875