

NASA Conference Publication 10003

# Aeropropulsion '87

## Session 5— Subsonic Propulsion Technology

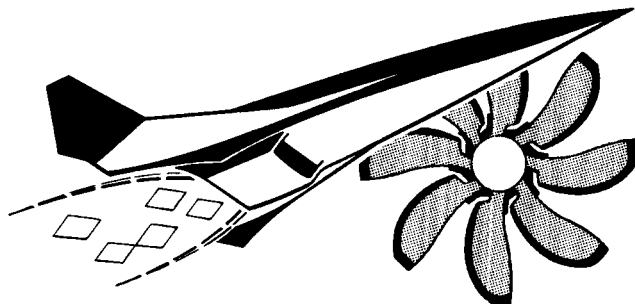

(NASA-CP-10003-Session-5) AEROPROPULSION '87.  
SESSION 5: SUBSONIC PROPULSION TECHNOLOGY  
(NASA) 153 p CSCL 21E

N88-15800  
--THRU--  
N88-15806  
Unclas  
0118874

H1/07

Preprint for a conference at  
NASA Lewis Research Center  
Cleveland, Ohio, November 17-19, 1987

**NASA**

NASA Conference Publication 10003

# **Aeropropulsion '87**

## **Session 5— Subsonic Propulsion Technology**

Preprint for a conference at  
NASA Lewis Research Center  
Cleveland, Ohio, November 17-19, 1987

**NASA**  
National Aeronautics and  
Space Administration

**CONTENTS**

	Page
<b>INTRODUCTION AND OVERVIEW OF THE SUBSONIC PROPULSION TECHNOLOGY SESSION</b>	
G. Keith Sievers . . . . .	5-1 <sub>51</sub>
<b>SMALL ENGINE TECHNOLOGY PROGRAMS</b>	
Richard W. Niedzwiecki . . . . .	5-13 <sub>52</sub>
<b>ROTORCRAFT TRANSMISSIONS</b>	
John J. Coy . . . . .	5-49 <sub>53</sub>
<b>THE NASA AIRCRAFT ICING RESEARCH PROGRAM</b>	
Robert J. Shaw and John J. Reinmann . . . . .	5-59 <sub>54</sub>
<b>AIRCRAFT ENGINE HOT SECTION TECHNOLOGY - AN OVERVIEW OF THE HOST PROJECT</b>	
Daniel E. Sokolowski and Marvin H. Hirschberg . . . . .	5-87 <sub>55</sub>
<b>OVERVIEW OF NASA PTA PROPFAN FLIGHT TEST PROGRAM</b>	
Edwin J. Graber . . . . .	5-97 <sub>56</sub>
<b>ADVANCED PROPELLER RESEARCH</b>	
John F. Groeneweg and Lawrence J. Bober . . . . .	5-123 <sub>57</sub>

**PRECEDING PAGE BLANK NOT FILMED**

OMIT

**INTRODUCTION AND OVERVIEW OF THE SUBSONIC  
PROPULSION TECHNOLOGY SESSION**

G. Keith Sievers

CONFERENCE FORMAT

This figure shows the program content and speakers for the Subsonic Propulsion Technology Session.

E-3798-Y

**SUBSONIC PROPULSION TECHNOLOGY SESSION**

**COCHAIRMEN:**

**GILBERT J. WEDEN  
G. KEITH SIEVERS**

**INTRODUCTION AND OVERVIEW  
SMALL ENGINE TECHNOLOGY PROGRAMS  
ROTORCRAFT TRANSMISSIONS  
AIRCRAFT ICING RESEARCH PROGRAMS  
HOT SECTION TECHNOLOGY  
ADVANCED TURBOPROP PROGRAM  
PROPFAN TEST ASSESSMENT PROJECT  
ADVANCED PROPFAN TECHNOLOGY**

**G. K. SIEVERS  
R. NIEDZWIECKI  
J. COY  
J. SHAW  
M. HIRSCHBERG  
E. GRABER  
J. GROENEWEG**

CD-87-29879

SMALL ENGINE TECHNOLOGY PROGRAMS

Ongoing small engine programs are indicated in this figure. The Automotive Gas Turbine (AGT) program is sponsored by the Department of Energy (DOE), and the Compound Cycle Turbine Diesel (CCTD) program is sponsored by the Army. There is a strong element of synergism between the various programs in several respects.

All the programs include research in high-temperature structural ceramics. This research tends to be generic in nature and has broad applications. The rotary technology and the CCTD programs are examining approaches to minimum heat rejection, or "adiabatic" systems employing advanced materials. The AGT program is also directed toward applications of ceramics to gas-turbine hot-section components.

Turbomachinery advances in the gas turbine programs will benefit advanced turbochargers and turbocompounders for the internal combustion (IC) system, and the fundamental understandings and analytical codes developed in the Research and Technology (R&T) programs will be directly applicable to the system projects.

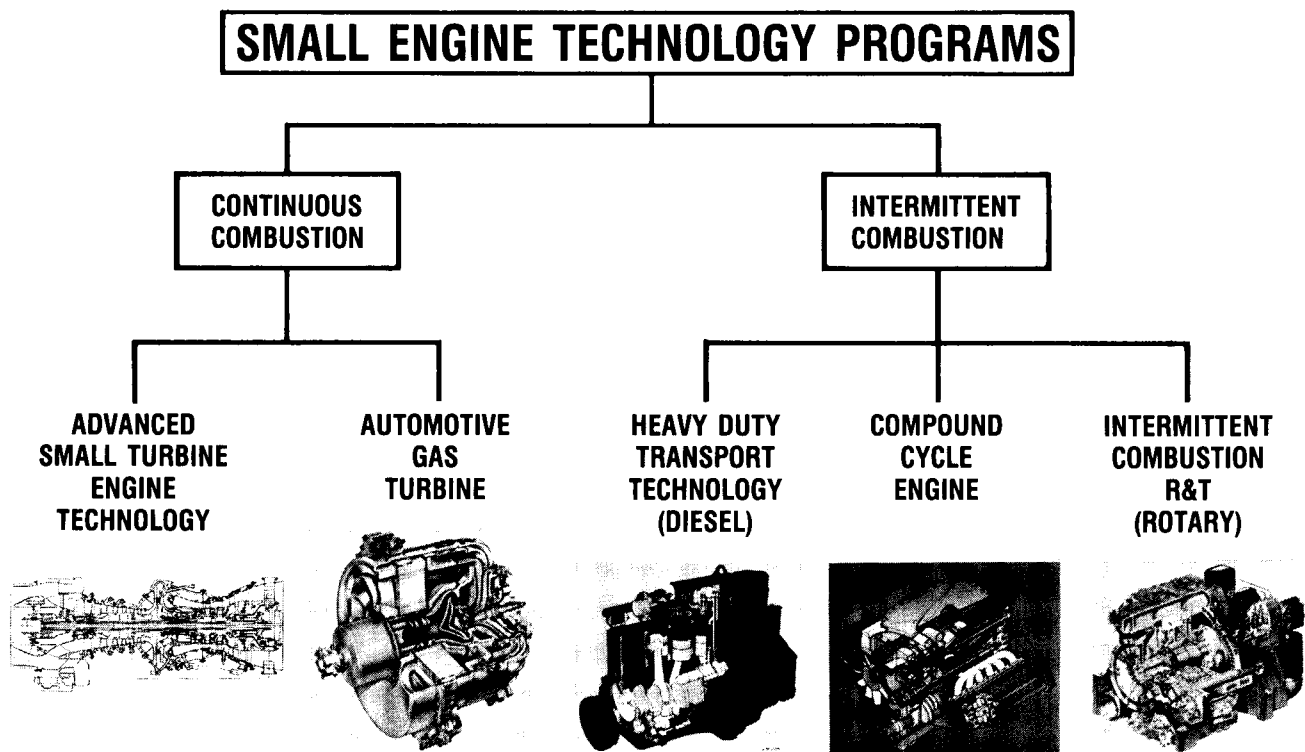

CD-87-29880

## SMALL ENGINE TECHNOLOGY THRUSTS

This chart shows technology opportunities for future major thrusts. Advanced cycles will be examined which offer the potential of large reductions in specific fuel consumption (SFC). New and enhanced computational tools will be developed, verified, and applied to advanced concepts to provide highly advanced, efficient, durable components. Advanced materials, such as ceramics and metal-matrix composites, will be applied to achieve maximum performance and life from the advanced engine concepts.

## SMALL ENGINE TECHNOLOGY THRUSTS

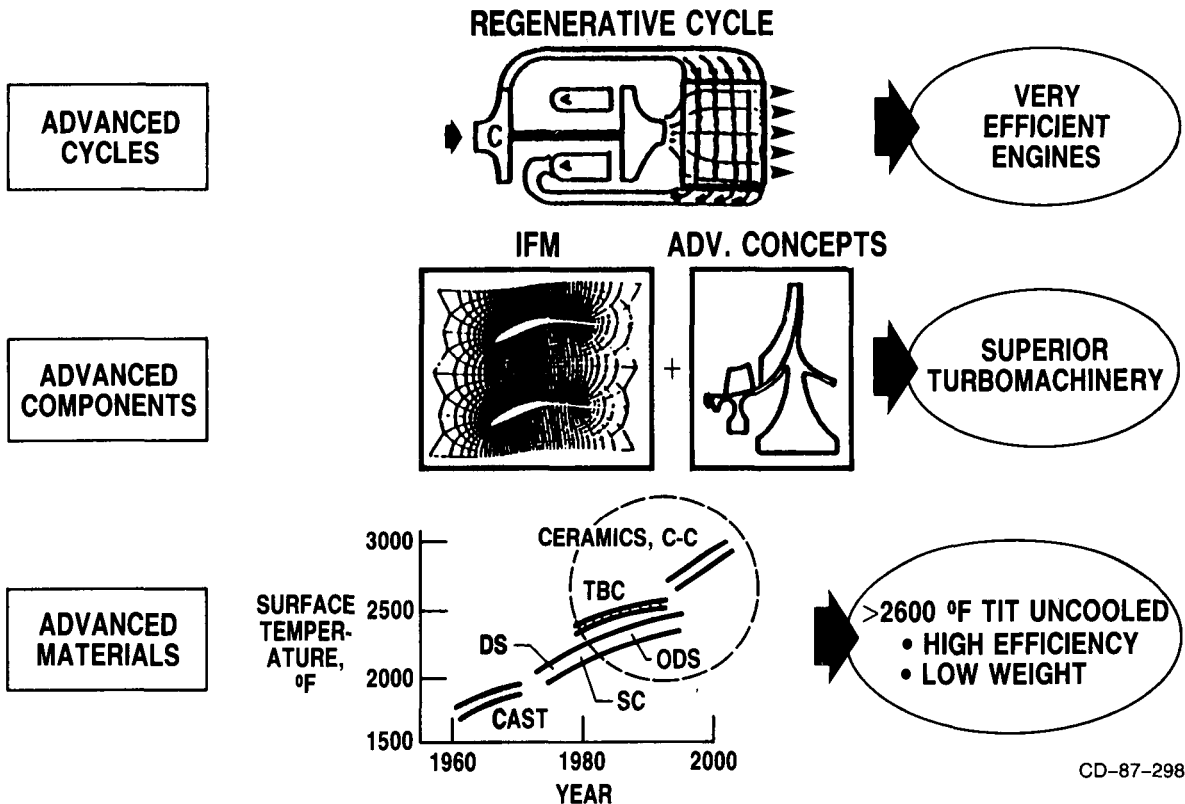

CD-87-29881

## ROTORCRAFT TRANSMISSIONS

Ongoing efforts involve computer code development and validation as well as analysis and optimization of components and full-scale transmissions. New tooth forms and gear material are being investigated for operation at higher temperatures and loads. Advanced transmission concepts (split-torque, bearingless planetary) are being explored for reduced weight and noise as well as increased life and reliability.

ORIGINAL PAGE IS  
OF POOR QUALITY.

## ROTORCRAFT TRANSMISSIONS

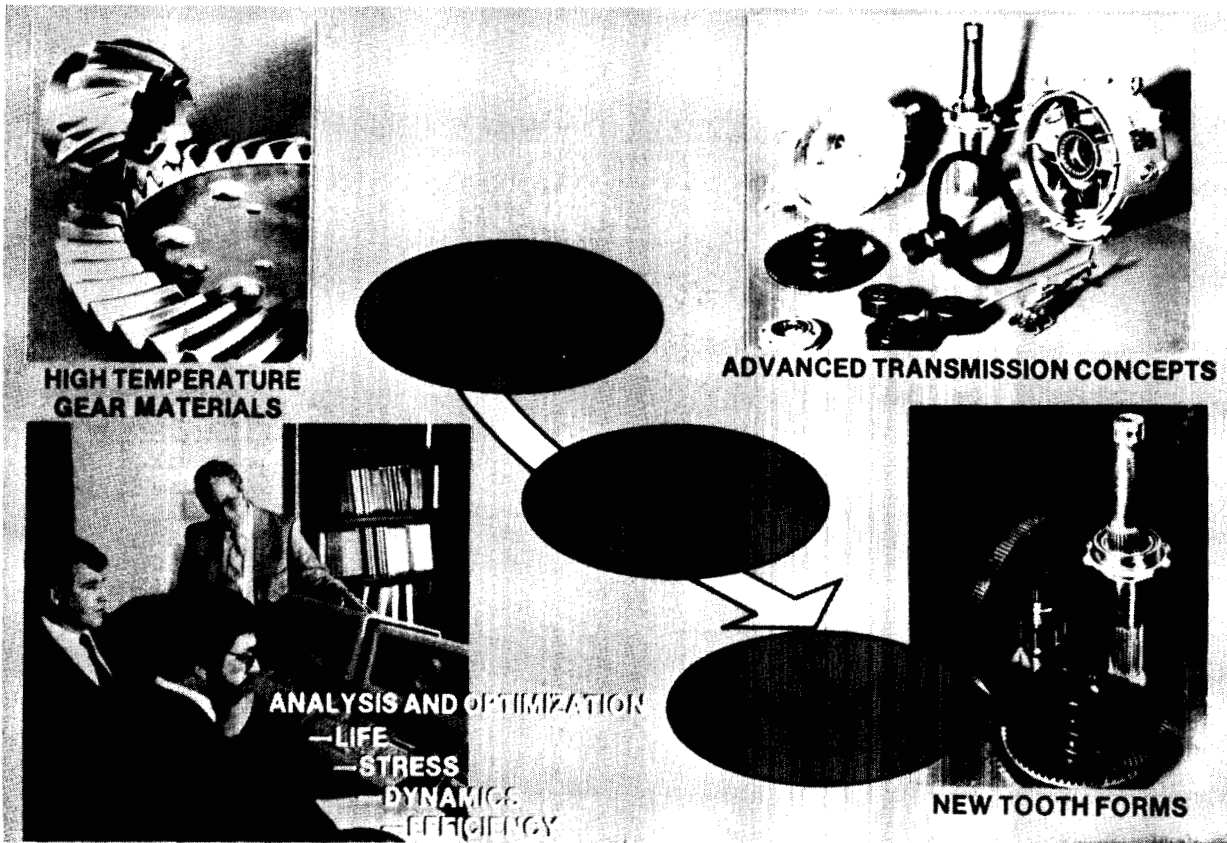

CD-87-29883

AIRCRAFT ICING RESEARCH PROGRAM

The NASA aircraft icing research program has two major technology thrusts: (1) development of advanced ice protection concepts and (2) development and validation of icing simulation techniques (both analytical and experimental). Technology is being developed that is applicable to both fixed and rotary wing aircraft.

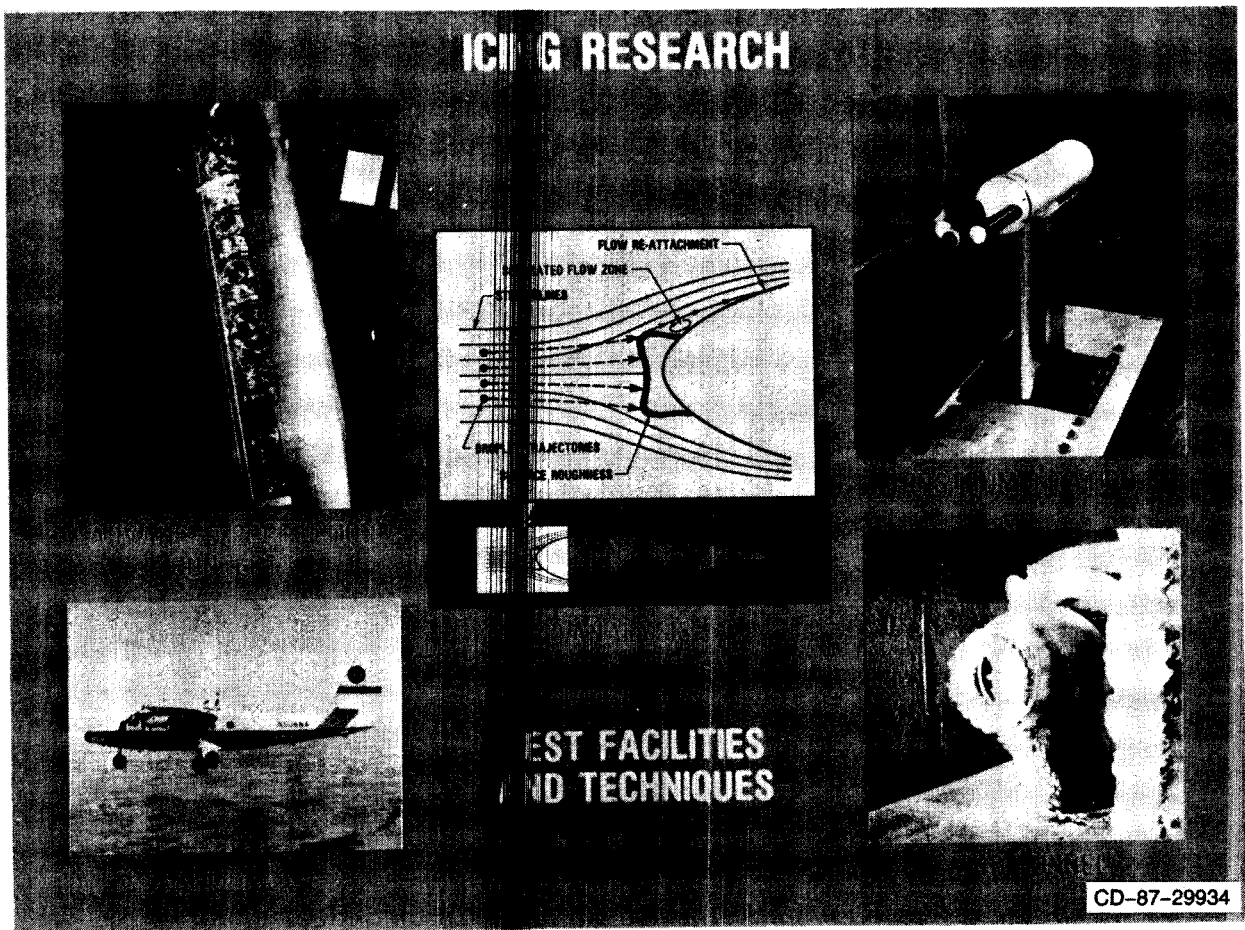



ENGINE HOT SECTION TECHNOLOGY

The activities of the NASA Turbine Engine Hot Section Technology (HOST) Project are directed toward durability needs, as defined in industry, and a more balanced approach to engine design. The HOST efforts will improve the understanding and prediction of thermal environments, thermal loads, structural responses, and life by focused experimental and analytical research activities. The overall approach is to assess existing analysis methods for strengths and deficiencies, to incorporate state-of-the-art improvements into the analysis methods, and finally to verify the improvements by benchmark quality experiments.

ORIGINAL PAGE IS  
OF POOR QUALITY

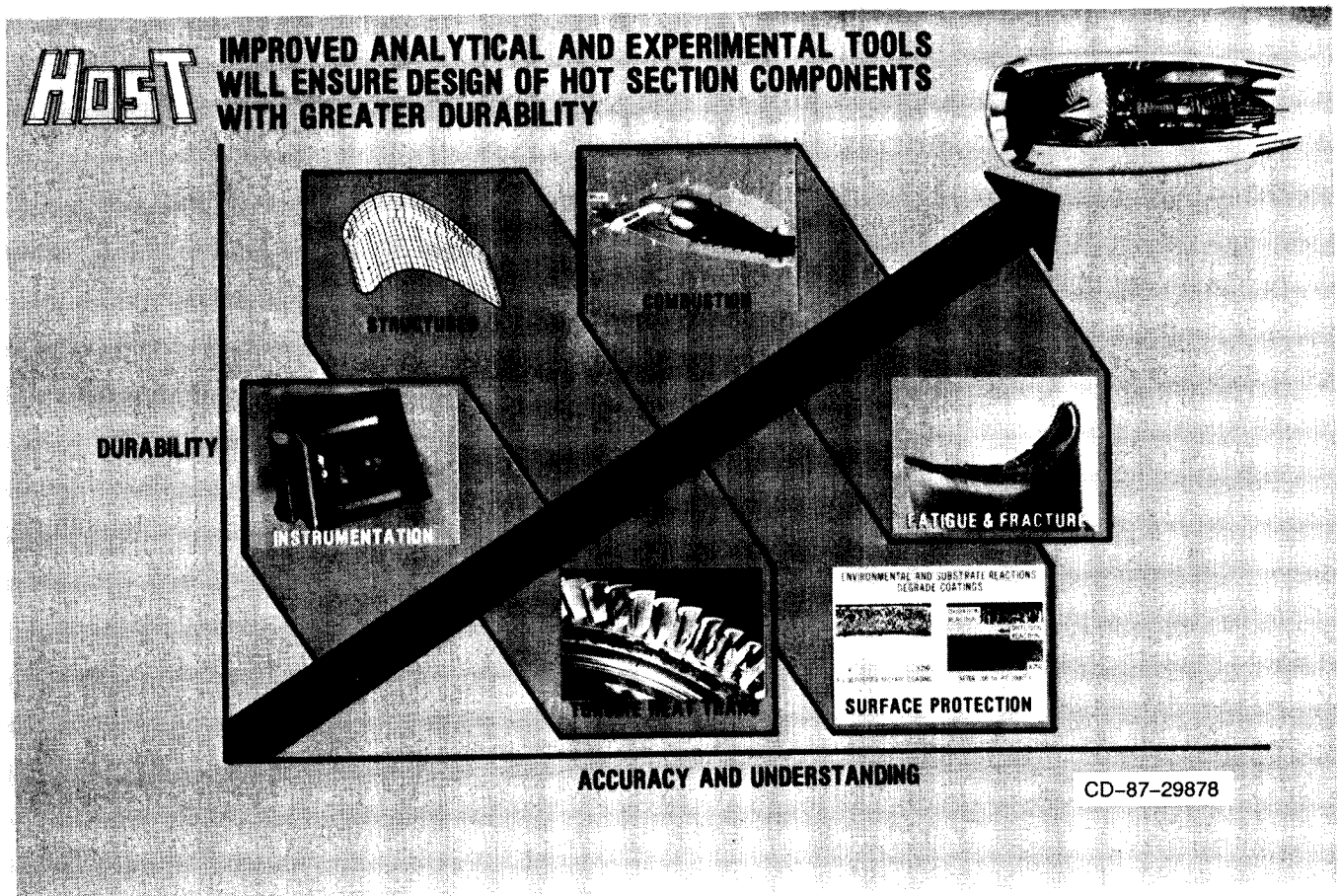

# ADVANCED TURBOPROP PROGRAM

This figure shows the overall content and flow of the Advanced Turboprop Program in the areas of single-rotation, gearless counterrotation, geared counterrotation, and into the area of advanced concepts.

ORIGINAL PAGE IS  
OF POOR QUALITY

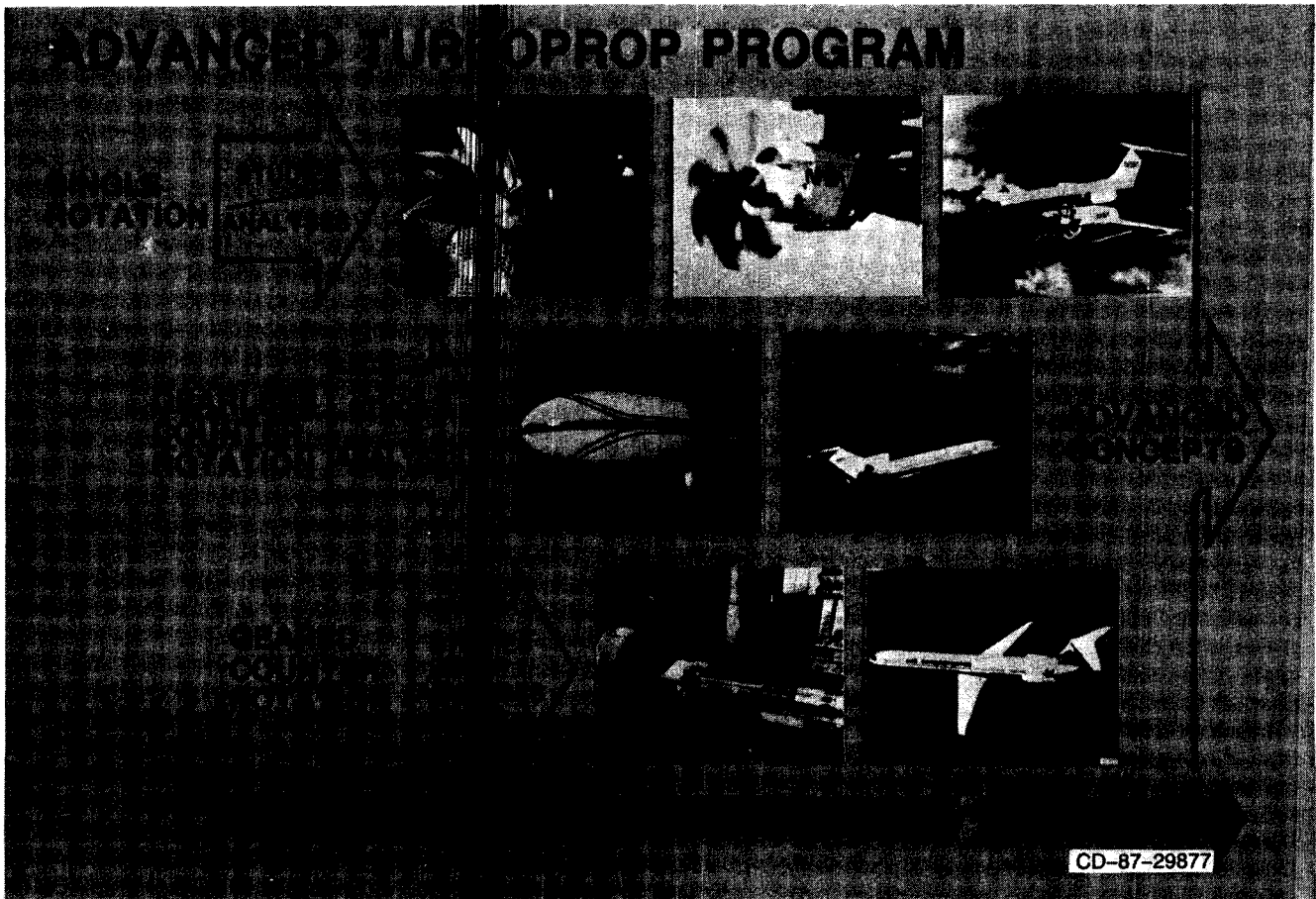

MAJOR CONTRACTUAL ELEMENTS OF ATP

This figure shows the major contractual elements of the Advanced Turboprop Program: the Large-Scale Advanced Propeller Project, the Propfan Test Assessment Project, the Unducted Fan Project, and the Advanced Gearbox Technology Project.

ORIGINAL PAGE IS  
OF POOR QUALITY

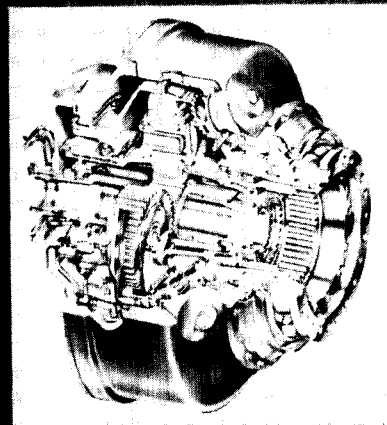
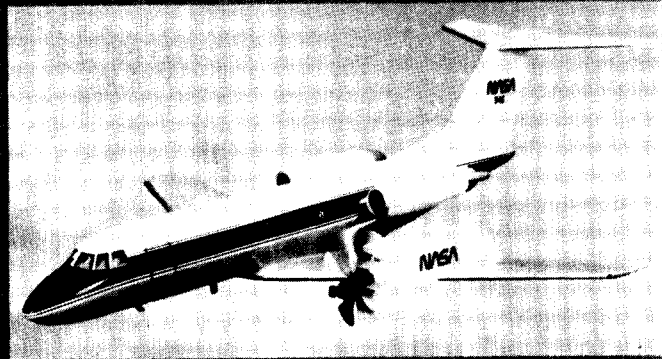
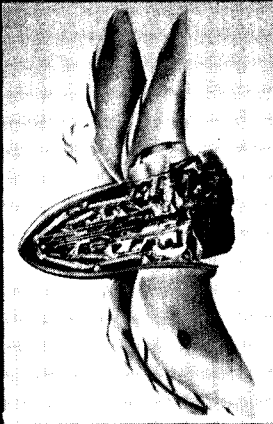

CD-87-29933

FLIGHT TESTING OF ADVANCED TURBOPROPS

This figure shows the four current flight test programs with advanced turboprops.

ORIGINAL PAGE IS  
OF POOR QUALITY

**ADVANCED TURBOPROP PROJECT  
FLIGHT TESTING OF ADVANCED TURBOPROPS**

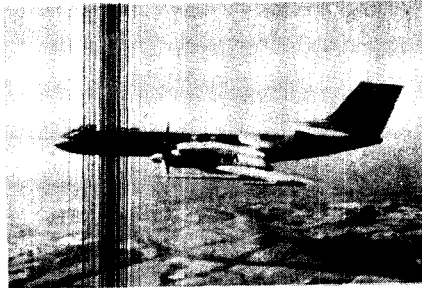

**PTA/GULFSTREAM GII**



**UDF/BOEING 727**

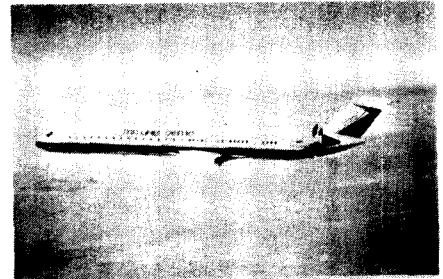

**UDF/MD-80  
578DX/MD-80**

CD-87-29932

## ATP APPLICATIONS

This figure shows an artist's conception of potential near-term applications of advanced turboprops in commercial and military aircraft.

ORIGINAL PAGE IS  
OF POOR QUALITY

### ATP ADVANCED TURBOPROP APPLICATIONS

**PASSENGER AIRCRAFT**

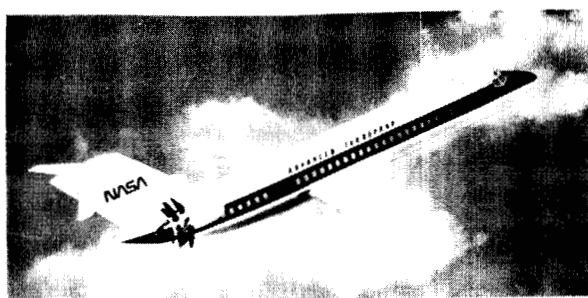

**CARGO AIRCRAFT**

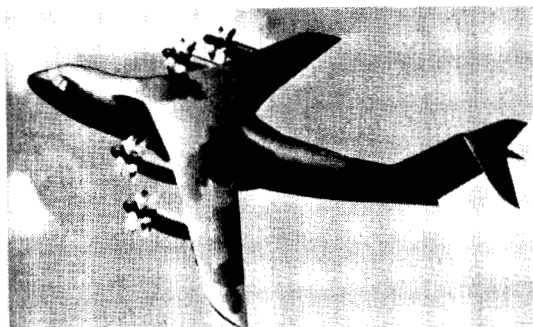

CD-87-29931

## PROPELLER RESEARCH

This figure shows the ongoing propeller research program of analysis and scale-model wind tunnel test verification leading to aerodynamic, acoustic, and structural code development. Advanced concepts of a single-rotation propfan with stator vane swirl recovery and a high-bypass-ratio ducted-fan configuration are illustrated.

ORIGINAL PAGE IS  
OF POOR QUALITY

## PROPELLER RESEARCH

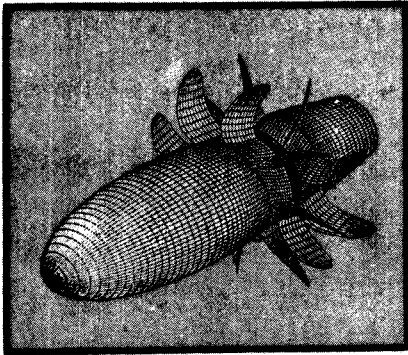

**ANALYSIS**

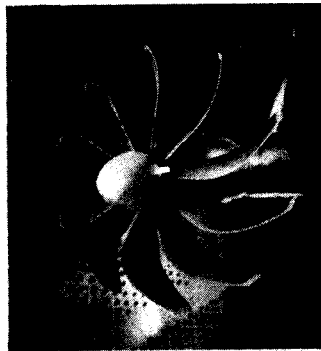

**VERIFICATION**

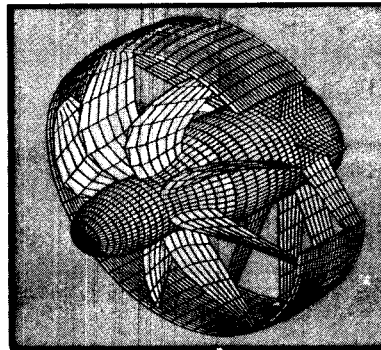
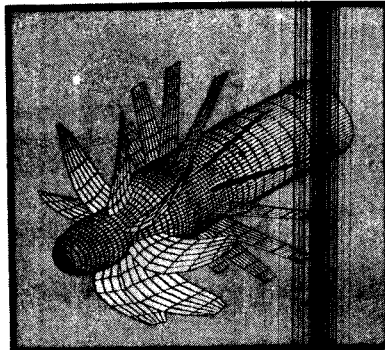

**ADVANCED CONCEPTS**

CD-87-29930

## HIGH-BYPASS ENGINES

This figure shows the potential reduction of SFC for propulsion systems using ducted props and propfans as compared to high-bypass turbofans. While the ducted props will not have the efficiency of unducted propfans, they are more suitable for "packaging" on large aircraft such as the B-747.

## HIGH-BYPASS ENGINES HAVE BETTER SUBSONIC PERFORMANCE

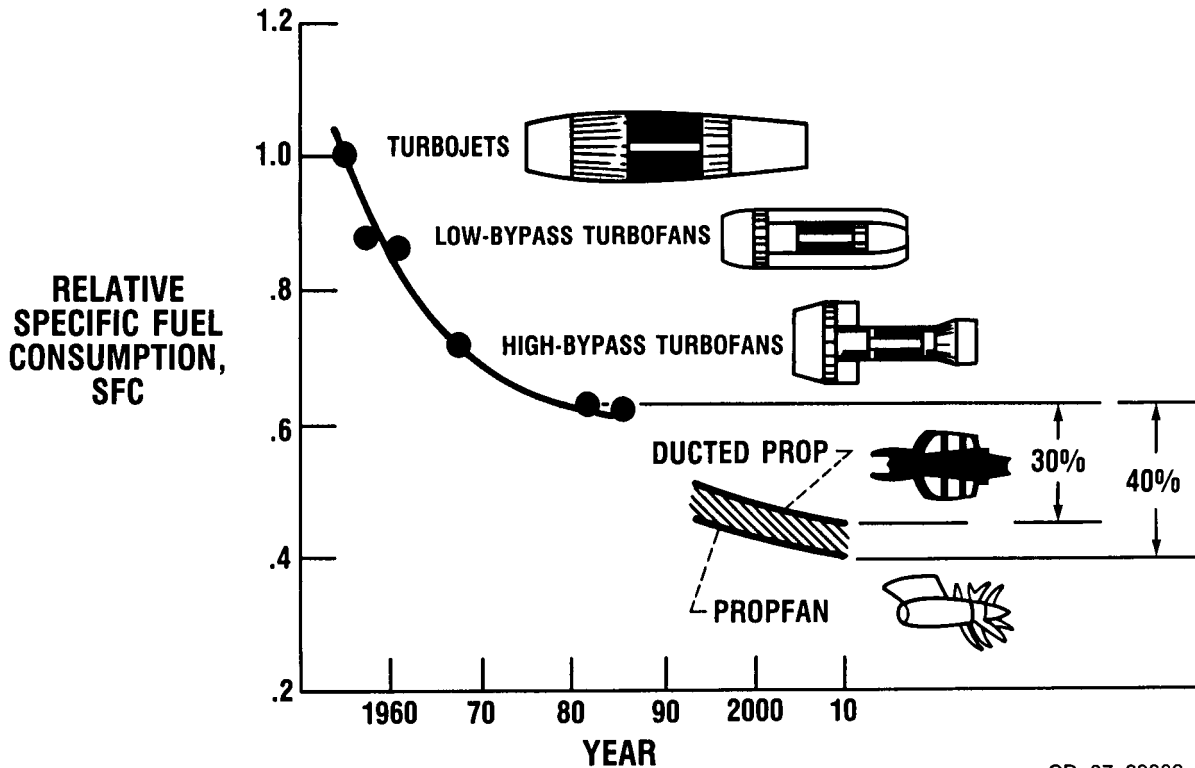

N88-15801

51-07  
118876  
358.

## SMALL ENGINE TECHNOLOGY PROGRAMS

Richard W. Niedzwiecki

### ABSTRACT

This paper describes small engine technology programs being conducted at the NASA Lewis Research Center. Small Gas Turbine Research, cosponsored by NASA and the Army, is aimed at general aviation, commutercraft, rotorcraft, and cruise missile applications. The Rotary Engine Program is aimed at supplying fuel flexible, fuel efficient technology to the general aviation industry, but also has applications to other missions. The Automotive Gas Turbine (AGT) and Heavy Duty Diesel Transport Technology (HDTT) Programs are sponsored by the Department of Energy. The Compound Cycle Engine Program is sponsored by the Army. There is a strong element of synergism between the various programs in several respects. All of the programs are aimed towards highly efficient engine cycles, very efficient components and the use of high temperature structural ceramics. This research tends to be generic in nature and has broad applications. The HDTT, rotary technology, and the compound cycle programs are all examining approaches to minimum heat rejection, or "adiabatic" systems employing advanced materials. The AGT program is also directed towards ceramics application to gas turbine hot section components. Turbomachinery advances in the gas turbine programs will benefit advanced turbochargers and turbocompounders for the intermittent combustion systems, and the fundamental understandings and analytical codes developed in the research and technology programs will be directly applicable to the system projects.



### SMALL ENGINE TECHNOLOGY PROGRAMS

Ongoing and proposed small engine programs are indicated in this figure. The Automotive Gas Turbine (AGT) and Heavy Duty Diesel Transport Technology (HDTT) programs are sponsored by DOE, and the Compound Cycle Turbine Diesel (CCTD) by the Army. There is a strong element of synergism between the various programs in several respects.

All of the programs will or presently include research in high temperature structural ceramics. This research tends to be generic in nature and has broad applications. The HDTT, the rotary technology and the CCTD are all examining approaches to minimum heat rejection, or "adiabatic" systems employing advanced materials. The AGT program is also directed towards ceramics application to gas-turbine hot-section components.

Turbomachinery advances in the gas turbine programs will benefit advanced turbochargers and turbocompounders for the I.C. systems, and the fundamental understandings and analytical codes developed in the R&T programs will be directly applicable to the system projects.

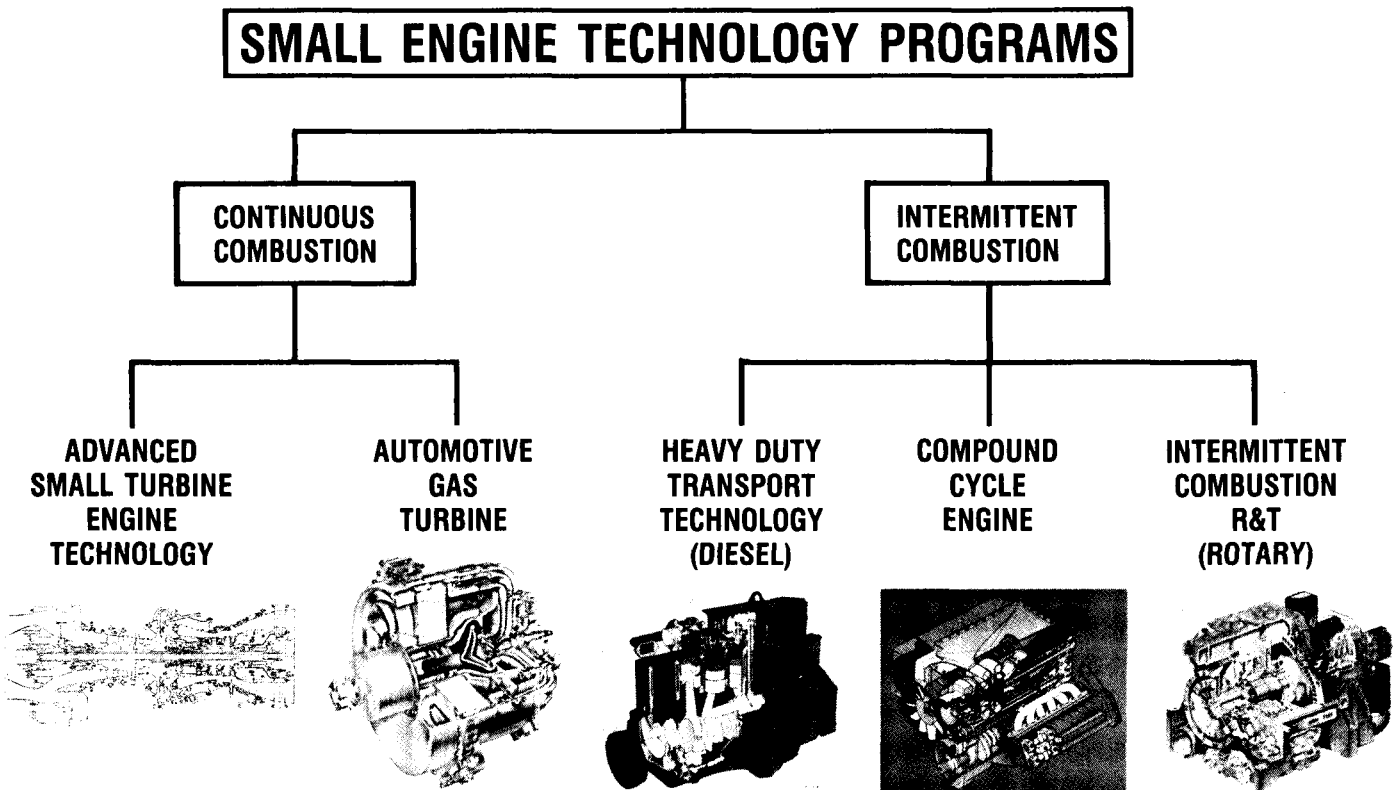

CD-87-29880

### SMALL ENGINES ARE NOT AS EFFICIENT

Previous investments in technology have led to significant efficiency gains for large engines. These gains have resulted from improved cycles, components, and materials. However, much of these technologies has not been transferable to smaller engines. As engine power size decreases, performance decreases due to the combined effects of increased relative clearances, lower Reynolds number, increased relative surface roughness, etc. These adverse effects are particularly noticeable below 200 shp. Small engines employ different component configurations such as centrifugal compressors, reverse flow combustors, and radial turbines to minimize these effects. Future large turbofan engines designed for ultra-high bypass ratios and higher cycle pressure ratios (greater than 50:1) will be limited in performance by some of the same size related problems which presently limit the performance of the small engines. This is a result of the inherent reduction in core engine flow size associated with the higher bypass ratio and the higher core pressure ratio, all of which reduces the turbomachinery size and the combustor length and volume. To counter the losses associated with the small turbomachinery blading, such things as replacing the back stages of the typically all axial compressors with a centrifugal stage is now being considered, following the same trends as for small engines.

### SMALL ENGINES ARE NOT AS EFFICIENT

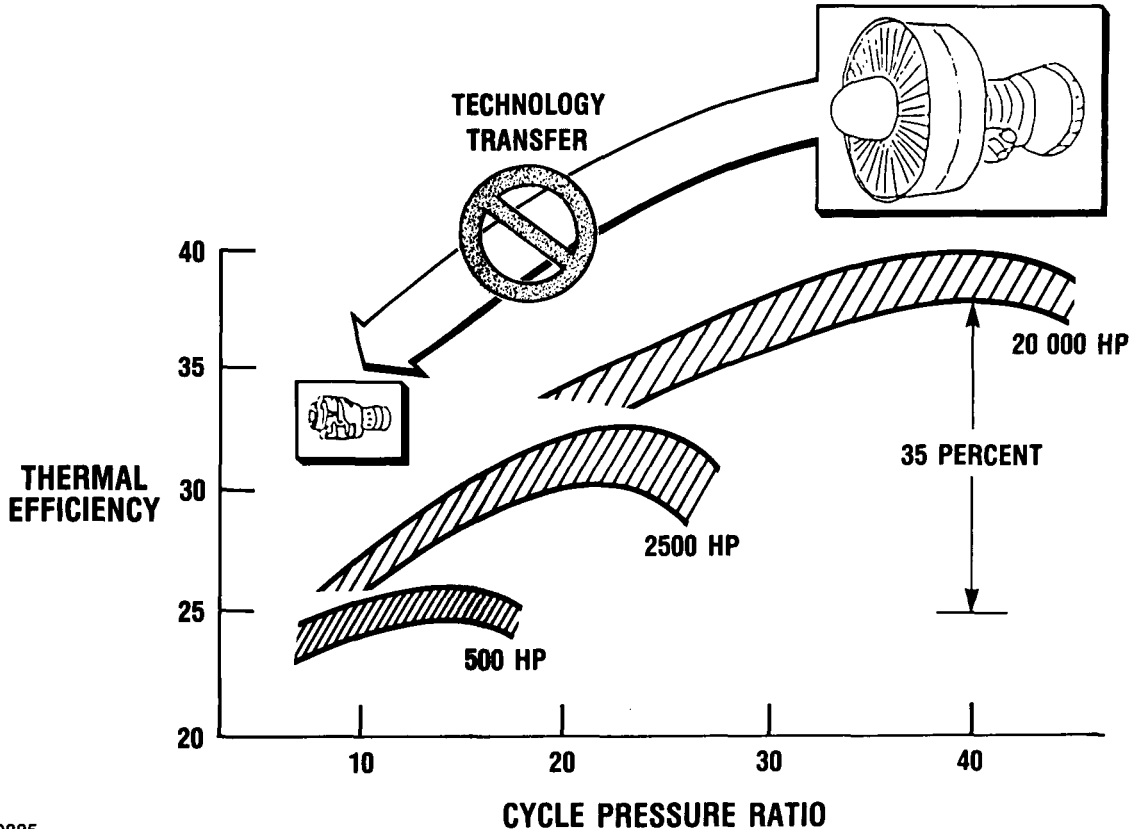

CD-87-29885

## SMALL ENGINE TECHNOLOGY OPPORTUNITIES

Small engines are used in a broad spectrum of aeronautical applications including helicopters, commuters, general aviation airplanes, and cruise missiles. In exploring engine types to satisfy these applications it has been determined that all of the engine types being researched have the potential of significantly improved efficiency. Shown is a plot of thermal efficiency and shaft horsepower. Gas turbines are considered prime candidates for horsepower ranges of 500 shp and higher. Their potential in efficiency improvement, over current engines, is of the order of 50 percent. The sources of this improvement will be presented later. The rotary engine is considered a prime candidate for missions up to 500 shp, but is not limited to that size range. Their potential for efficiency improvement is similar to the gas turbine. The compound cycle diesel is being considered for missions requiring engines in the 750 to 2000 shp class. Their potential for improvement is comparable to the other engine types being researched.

## SMALL ENGINE TECHNOLOGY OPPORTUNITIES



**GENERAL  
AVIATION**

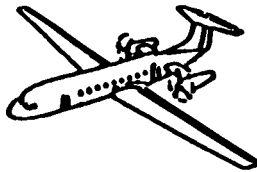

**COMMUTER**



**HELICOPTER**

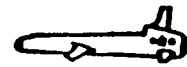

**CRUISE  
MISSILE**

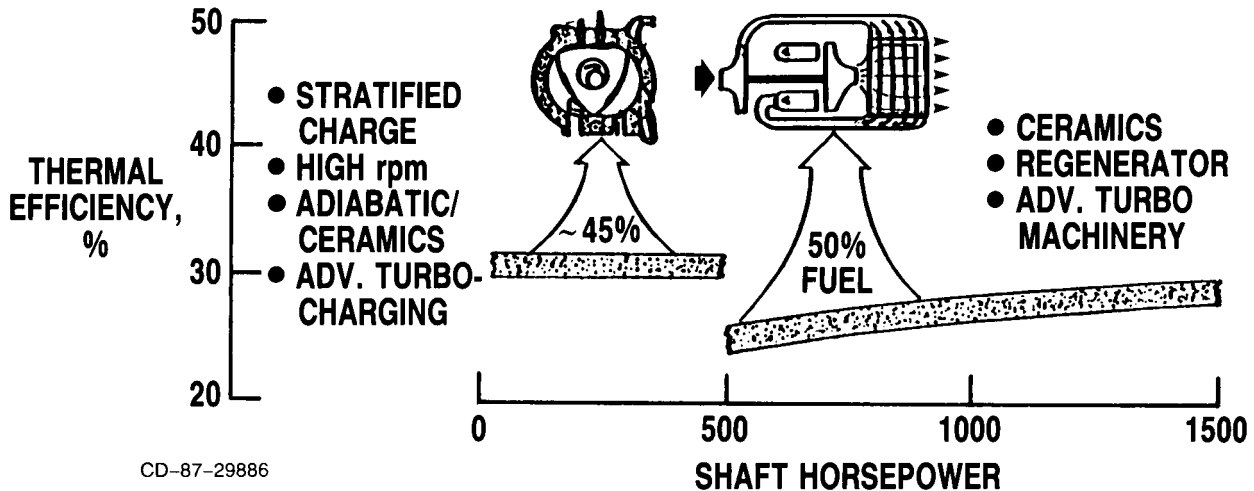

## SMALL ENGINE TECHNOLOGY OPPORTUNITIES

This chart provides examples of technology opportunities for each of the major thrusts noted in the previous chart. Advanced cycles will be examined which offer the potential for large reductions in SFC. New and enhanced computational tools will be developed, verified, and applied to advanced concepts to provide highly advanced, efficient, durable components. Advanced materials such as ceramics and metal matrix composites will be applied to achieve the maximum performance and life from the advanced engine concepts.

## SMALL ENGINE TECHNOLOGY THRUSTS

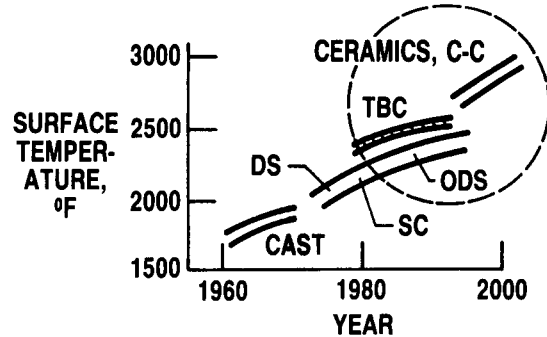
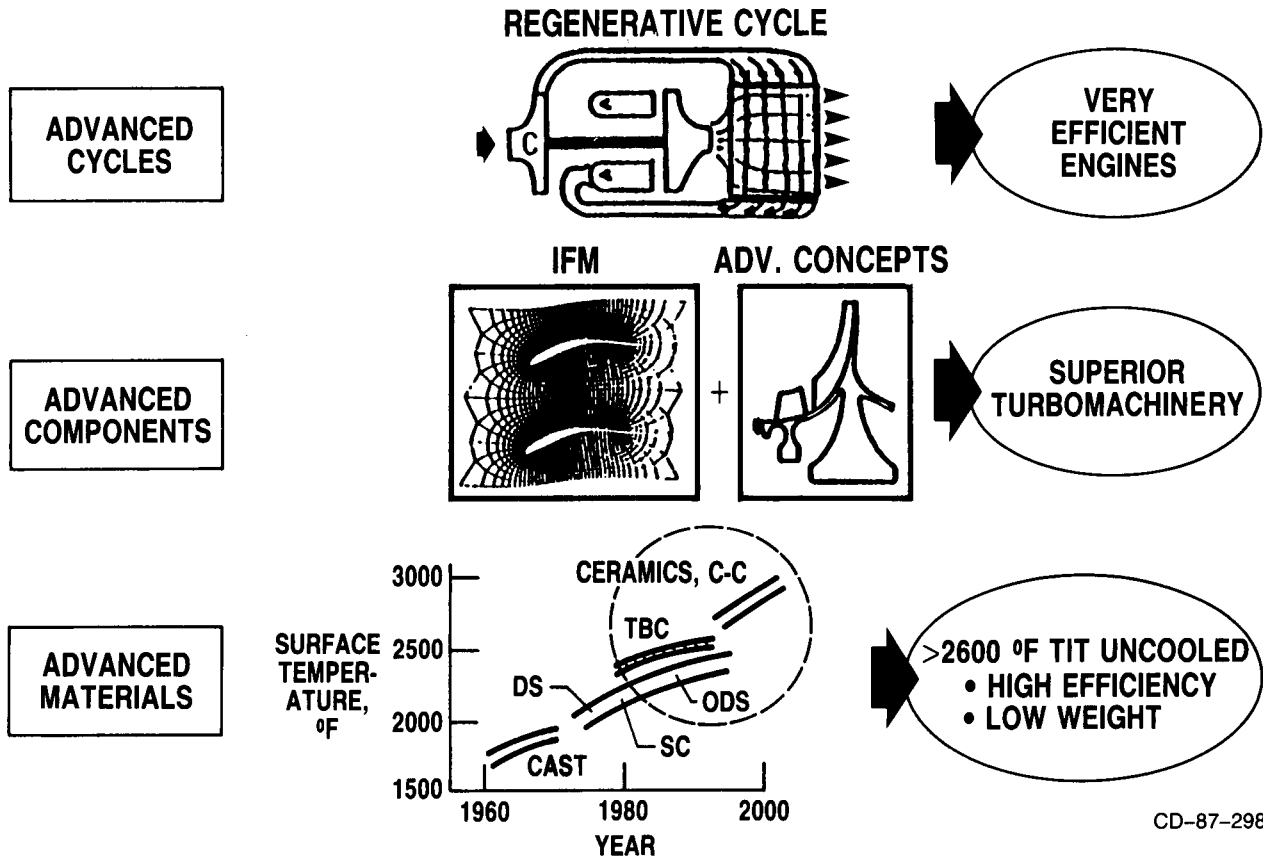

IMPACT OF FUEL ON MILITARY MISSION FLEXIBILITY  
(FROM BATTLEFIELD SCENARIOS)

This chart illustrates the reasons for the keen military interest in substantially reducing specific fuel consumption of their engines.

**IMPACT OF FUEL ON MILITARY MISSION FLEXIBILITY  
FROM BATTLEFIELD SCENARIOS**

- **FUEL IS 70 PERCENT OF TONNAGE SHIPPED**
- **ARMOR/MECH/INF DIVISIONS**
  - AVIATION: 100,000 GAL/DAY PER DIV
  - GROUND: 50,000 GAL/DAY PER DIV
  - FOR 15,000 MAN DIVISION, 10 GAL/DAY/MAN PER DIV
- **AIR ASSAULT DIVISION**
  - AVIATION: 320,000 GAL/DAY PER DIV
  - GROUND: 20,000 GAL/DAY PER DIV
  - FOR 15,000 MAN DIVISION, 22 GAL/DAY/MAN PER DIV

**• A 50 PERCENT SAVINGS IN AVIATION FUEL CAN SIGNIFICANTLY REDUCE TOTAL TONNAGE SHIPPED, THUS INCREASING MISSION CAPABILITY AND FLEXIBILITY.**

CD-87-29887

## SMALL ENGINE TURBINE TECHNOLOGY

Many programs proposed previously have tended to be "evolutionary", focused on incremental improvements in component capabilities. This objective reflects our intent to establish a program which will lead to a major advance in small engine technology. We believe that "revolutionary" powerplant improvements will have a truly significant impact, and will lead to a new generation of airframes with greatly expanded capabilities.

## SMALL TURBINE ENGINE TECHNOLOGY

**TARGET: IMPROVE FUEL CONSUMPTION BY 40 PERCENT AND REDUCE DOC BY 10 PERCENT  
BY USE OF IMPROVED MATERIALS AND DESIGN CONCEPTS.**

CD-87-29888

## SMALL ENGINE COMPONENT TECHNOLOGY (SECT) STUDIES

This figure presents the contractor selected applications for which their studies will be based. At least two contractors are pursuing studies in each application area noted previously (rotorcraft, commuter/general aviation, and cruise missiles). One contractor is also pursuing studies for APU's. The studies will provide results on a broad range of applications from a wide spectrum of the industry.

### SMALL ENGINE COMPONENT TECHNOLOGY (SECT) STUDIES CONTRACTOR SELECTED APPLICATIONS

<u>CONTRACTOR</u>	<u>ROTORCRAFT 500-1,000 HP</u>	<u>GENERAL AVIATION/ COMMUTER 500-1,000 HP</u>	<u>APU 300-500 HP</u>	<u>CRUISE MISSILE 200-1,000 LB T</u>
ALLISON	X			
AVCO LYCOMING		X		
GARRETT	X	X	X	X
TELEDYNE CAE				X
WILLIAMS INTERNAT'L				X

CD-87-29917

## SMALL ENGINE COMPONENT TECHNOLOGY (SECT) STUDIES

The Small Engine Component Technology (SECT) studies were conducted, under joint NASA/Army funding, to provide a critical assessment by the small turbine industry on the technology needs for the year 2000 engines. The results of the studies will have a significant impact on the technology to be pursued in future programs. Study contractors were Allison, Avco Lycoming, Garrett, Teledyne CAE and Williams International. General Electric and Pratt & Whitney also conducted parallel studies and made the results available for the technology assessments. Missions studies included rotorcraft in the 500 to 1,000 hp size; General Aviation/Commuter missions in the 500 to 1000 hp size; Auxiliary Power Units in the 300 to 500 hp size; and Cruise Missiles in the 200 to 1000 lb T size.

Study results in terms of benefits, high payoff research areas, and national benefits achieved from the evolved research are shown on this chart for the various missions. Other required technologies identified, which while difficult to identify direct benefits from, but are critical to achieving significant fuel savings and DOC/LCC reductions include bearings, shafts, seals, gearbox and slurry fuel combustion for the cruise missile engines.

## SMALL ENGINE COMPONENT TECHNOLOGY (SECT) STUDIES (JOINT NASA/ARMY PROGRAM)

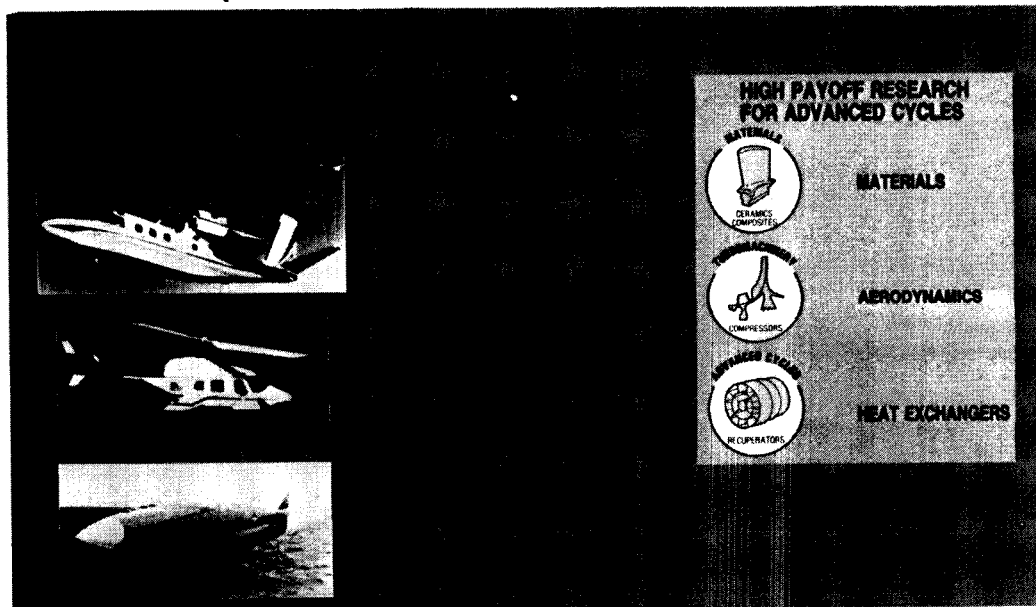

- NATIONAL BENEFITS**
- \$1-\$3 BILLION SAVINGS IN OPERATING COSTS IN 15 YEARS.
  - 2-3 YEAR PAYBACK FOR R&D INVESTMENT.
  - SIGNIFICANT MILITARY ADVANTAGES.
  - STRENGTHEN U.S. COMPETITIVE EDGE IN FUTURE WORLD MARKET.

CD-87-29889



## STATE-OF-THE-ART CYCLE PERFORMANCE

This figure presents the performance for a state-of-the-art (SOA) 800 shp (uninstalled) simple-cycle gas turbine. It is used as a reference for comparison to advanced cycles. A turbine inlet temperature of 2200 °F and a pressure ratio of 14:1 were assumed as being representative for the state-of-the-art. In addition, state-of-the-art component efficiencies and combustor/turbine cooling requirements were assumed. The BSFC for these conditions is approximately 0.43 lbs/shp-hr and the specific power approximately 180 shp/lb/sec.

## STATE-OF-THE-ART CYCLE PERFORMANCE 800 HP SLS

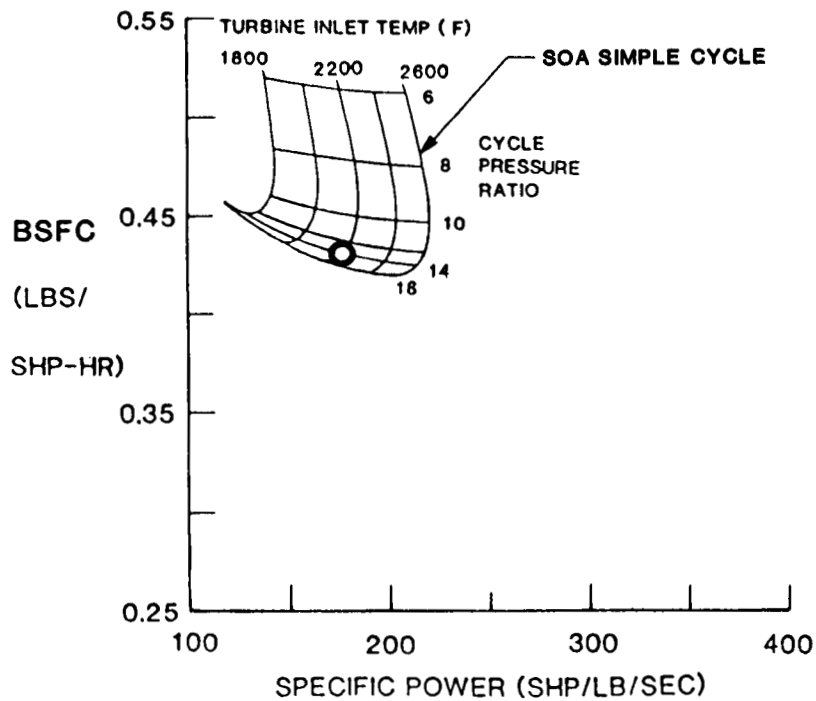

CD-87-29916

## IMPACT OF ADVANCED TECHNOLOGY ON CYCLE PERFORMANCE

This figure presents two engine performance maps. The top map presents the performance for a state-of-the-art (SOA) 800 shp (uninstalled) simple-cycle gas turbine. It is used as a reference for comparison to advanced cycles. A turbine inlet temperature of 2200 °F and a pressure ratio of 14:1 were assumed as representative for the SOA engine. In addition, SOA component efficiencies and combustor/turbine cooling requirements were assumed. The BSFC for these conditions is approximately 0.43 lb/shp-hr and specific power approximately 180 shp/lb/sec.

The bottom engine map presents the performance for an advanced simple-cycle for comparison to the SOA. For the advanced engine, advance component efficiencies were assumed along with higher operating pressures to 24:1, higher temperatures to 2600 °F, and uncooled ceramics. The advanced BSFC of 0.36 lb/hp-hr is 17 percent less than the SOA and its specific power is 55 percent higher. Of the 17 percent improvement, 8 percent is attributed to advanced component efficiencies, 4 percent is due to the higher cycle pressure, temperature, and reduced turbine coolant penalty, and 5 percent results from totally eliminating the coolant penalty by using uncooled ceramics. Uncooled ceramics also have the potential for reducing costs.

## IMPACT OF ADVANCED TECHNOLOGY ON CYCLE PERFORMANCE

800 HP SLS

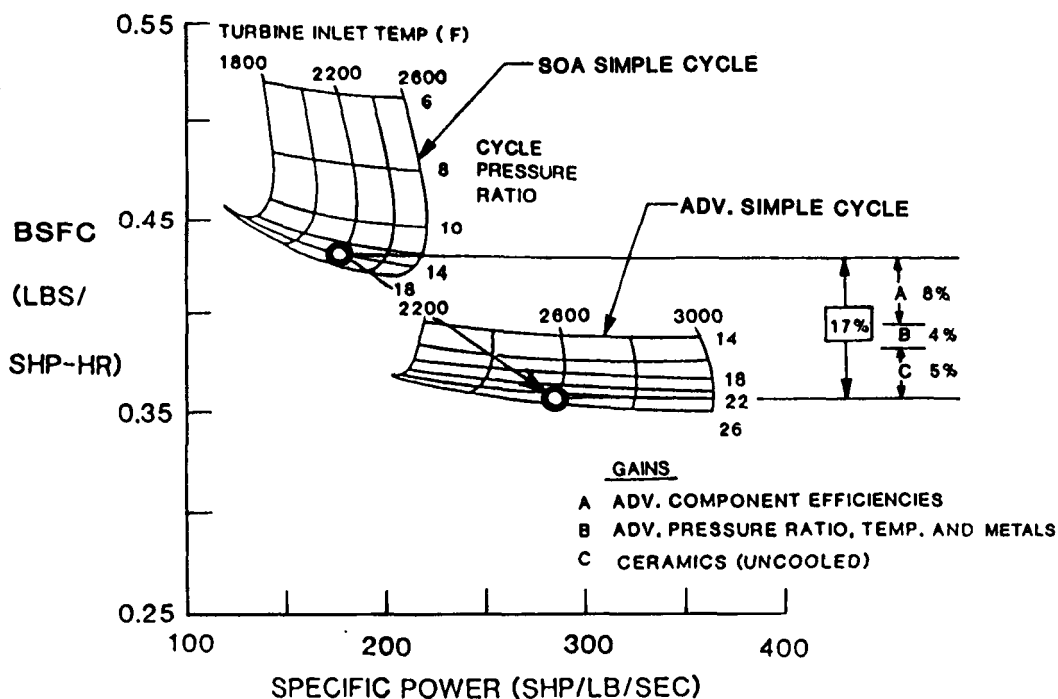

CD-87-29890

## IMPACT OF ADVANCED TECHNOLOGY ON CYCLE PERFORMANCE

This figure presents the performance for an advanced regenerated cycle in comparison to the state-of-the-art simple-cycle and advanced simple-cycle. Again, advanced component efficiencies were assumed along with the high turbine inlet temperature of 2600 °F and uncooled ceramics. In terms of BSFC, the advanced regenerated cycle provides the potential for a very significant 37 percent reduction over the state-of-the-art simple-cycle along with some increase in specific power. Note, however, the optimum cycle pressure ratio for the regenerated cycle is much lower than that for the advanced simple cycle, thus resulting in fewer compression stages required. Regenerative cycles could utilize either a rotary regenerator or a stationary recuperator.

While these potential performance gains are quite large, they must be examined in a representative mission model, taking into consideration projected changes in engine size, weight, cost and other factors before the real benefit of the ASET program can be assessed. Because of the diversity of small engine applications, several representative missions have been selected for study.

### IMPACT OF ADVANCED TECHNOLOGY ON CYCLE PERFORMANCE 800 HP SLS

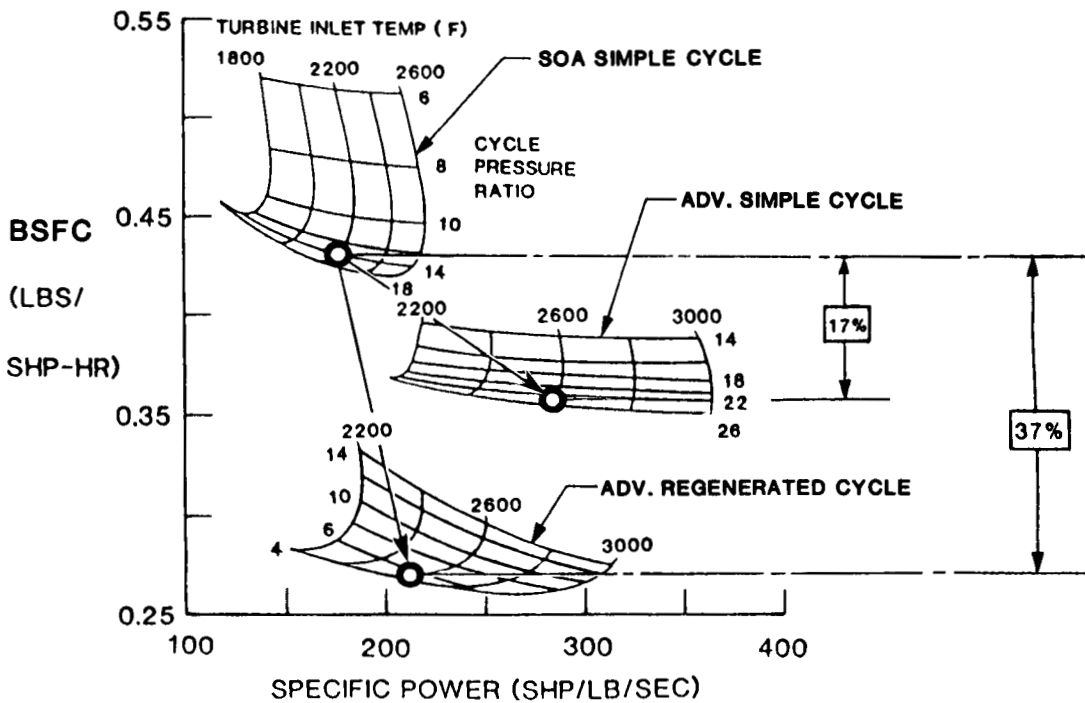

CD-87-29891

## COMPRESSOR EFFICIENCY

This curve was derived from actual data. It is a plot of compressor polytropic efficiency as a function of compressor exit corrected flow in pounds per second. The solid line represents advanced, current technology. The 10-lb/sec efficiency value of 92 percent is energy efficient engine data. As you can see, reducing flow size causes significant decreases in efficiency, until at 1 lb/sec the efficiency drops to approximately 78 percent. Identifying the causes for the efficiency falloff and minimizing their effects, is a major thrust of the compressor program. Agressive program goals are indicated by the dashed line.

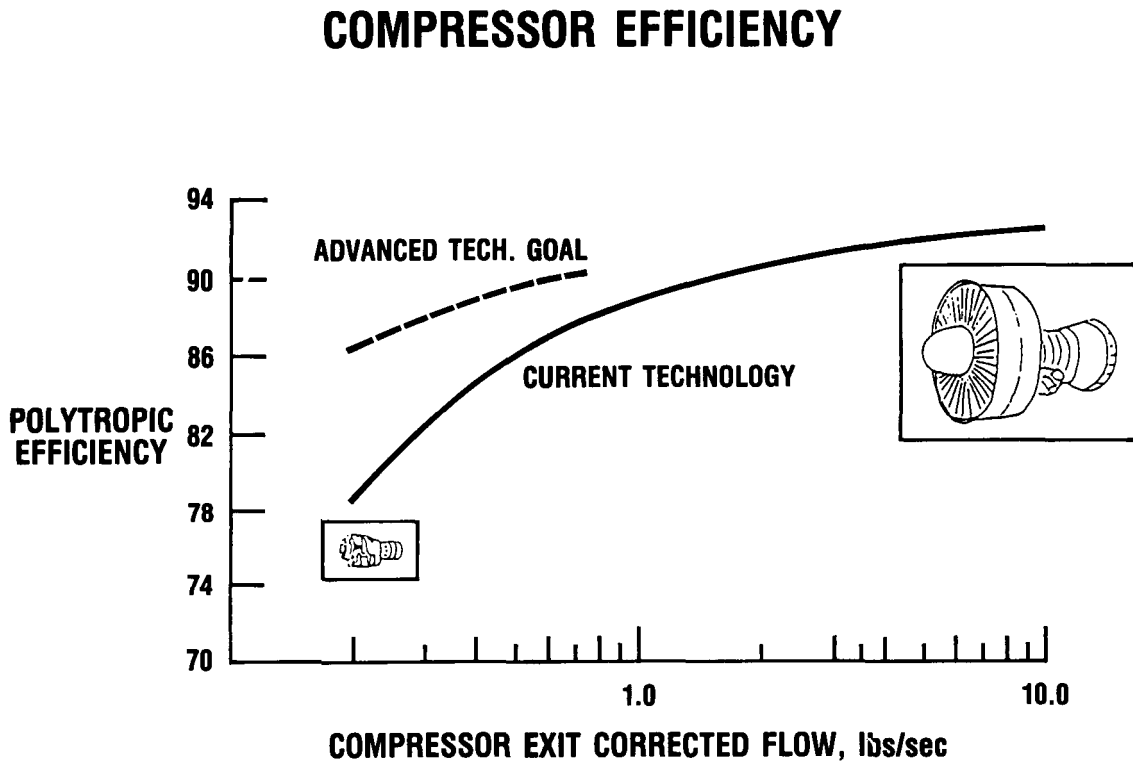

CD-87-29892

COMPRESSOR TECHNOLOGY

Major thrust of the compressor technology program consist of the following:

- (1) Axial and centrifugal compressor research aimed at the achievement of higher pressure ratios, increased efficiency and reduced number of stages with higher loading per stage.
- (2) Quantifying and minimizing performance degradation factors accruing with reductions in flow size.
- (3) Evolving improved design techniques through the development of improved analytical models and codes.
- (4) Verifying and improving analytical models through the use of advanced diagnostics including laser anemometry.

### COMPRESSOR TECHNOLOGY

AXIAL

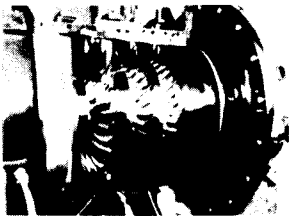

- HIGHER PRESSURE RATIOS
- INCREASED EFFICIENCY
- REDUCE NUMBER OF STAGES

CENTRIFUGAL



PERFORMANCE DEGRADATION FACTORS

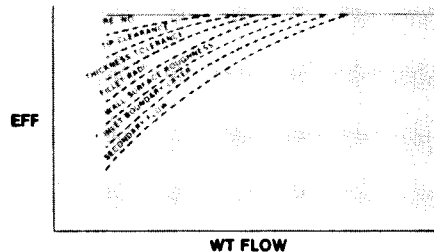

QUANTIFY/MINIMIZE EFFECT WITH FLOW SIZE

COMPUTER-AIDED ANALYSIS

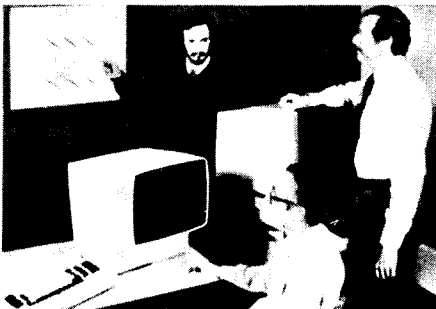

DEVELOP ANALYTICAL MODELS AND CODES

LASER ANEMOMETRY

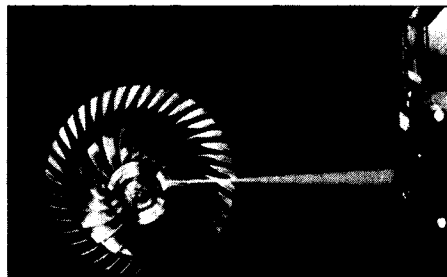

OBTAIN DETAILED INTERNAL FLOW MEASUREMENT

CD-87-29893

SCALED CENTRIFUGAL COMPRESSOR PROGRAM

The program described in the slide was conducted to determine performance degradation with flow size. A 25-lb/sec centrifugal compressor was scaled down to a 10-lb/sec size. It was then attempted to scale the 10-lb/sec size. It was then attempted to scale the 10-lb/sec compressor to a 2-lb/sec size. This was not possible, due principally to wall thickness. A 2-lb/sec "doable" compressor was designed and scaled to the 10-lb/sec size. Research was then conducted with thin and thick blade 10-lb/sec compressors and the thick blade 2-lb/sec compressor wheels.

SCALED CENTRIFUGAL COMPRESSOR PROGRAM

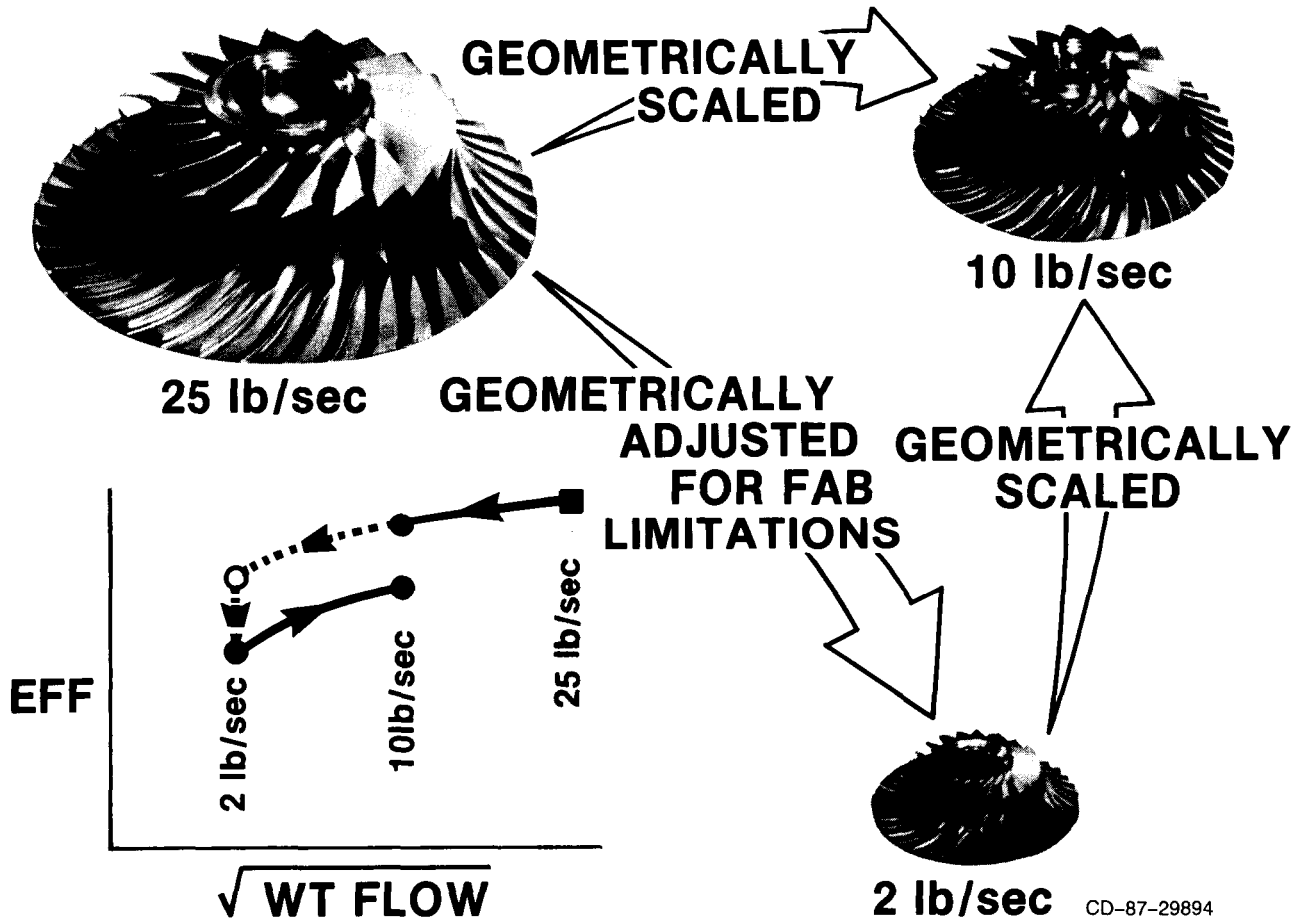

CD-87-29894

## PERFORMANCE DEGRADATION FACTORS

The performance degradation factors shown on the slide were quantified for the three compressor wheels. Results were recently reported at the San Diego AIAA meeting.

## PERFORMANCE DEGRADATION FACTORS

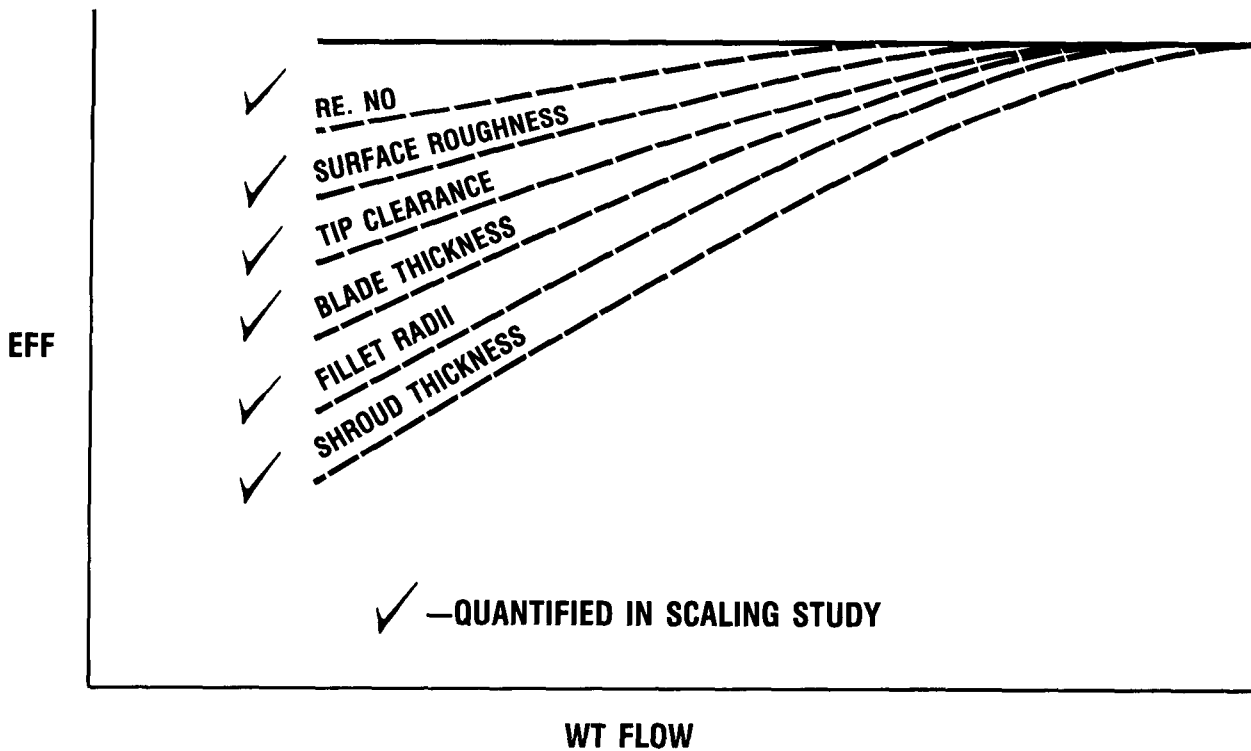

CD-87-29895

## EFFECT OF SCALING ON CENTRIFUGAL COMPRESSOR PERFORMANCE

This figure shows the peak efficiency loss that occurs as Reynolds number is varied for the 2-lb/sec and 10-lb/sec centrifugal compressors. The data from both compressors fall along a straight line. This indicates that the scaling laws hold within this size range. One of the problems in designing efficient small compressors is that they operate at lower Reynolds numbers which inherently produce increased inefficiency.

## EFFECT OF SCALING ON CENTRIFUGAL COMPRESSOR PERFORMANCE

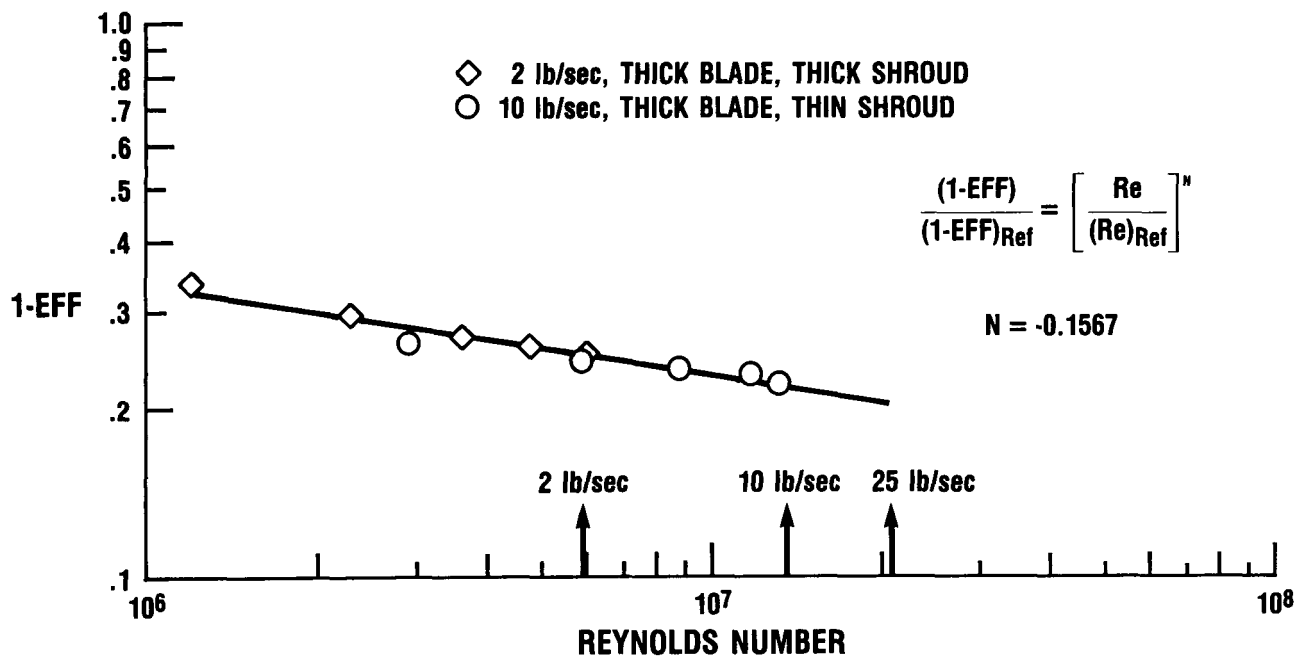

CD-87-29896



## TURBINE EFFICIENCY

This figure is a plot of turbine efficiency as a function of turbine inlet corrected flow. The top figure (a) is for gas generator turbines. The dashed line represents current gas generator turbine technology for axial turbines. Actual data was used to construct this plot the higher flow rate incorporating energy efficient engine data. As can be seen, an efficiency drop-off of over 4 percent occurs as size is reduced.

The top, shaded-in curve represents program goals for axial turbines. It also represents radial turbine data. Radial turbines are very efficient. However there is not any currently on flying engines because other technologies they require have not evolved. The prime technology need for radial turbines is a method for satisfactorily cooling them. The bottom section of the chart (b) represents the current state of the art for axial power turbines (dashed line). Program goals are shown by the solid line.

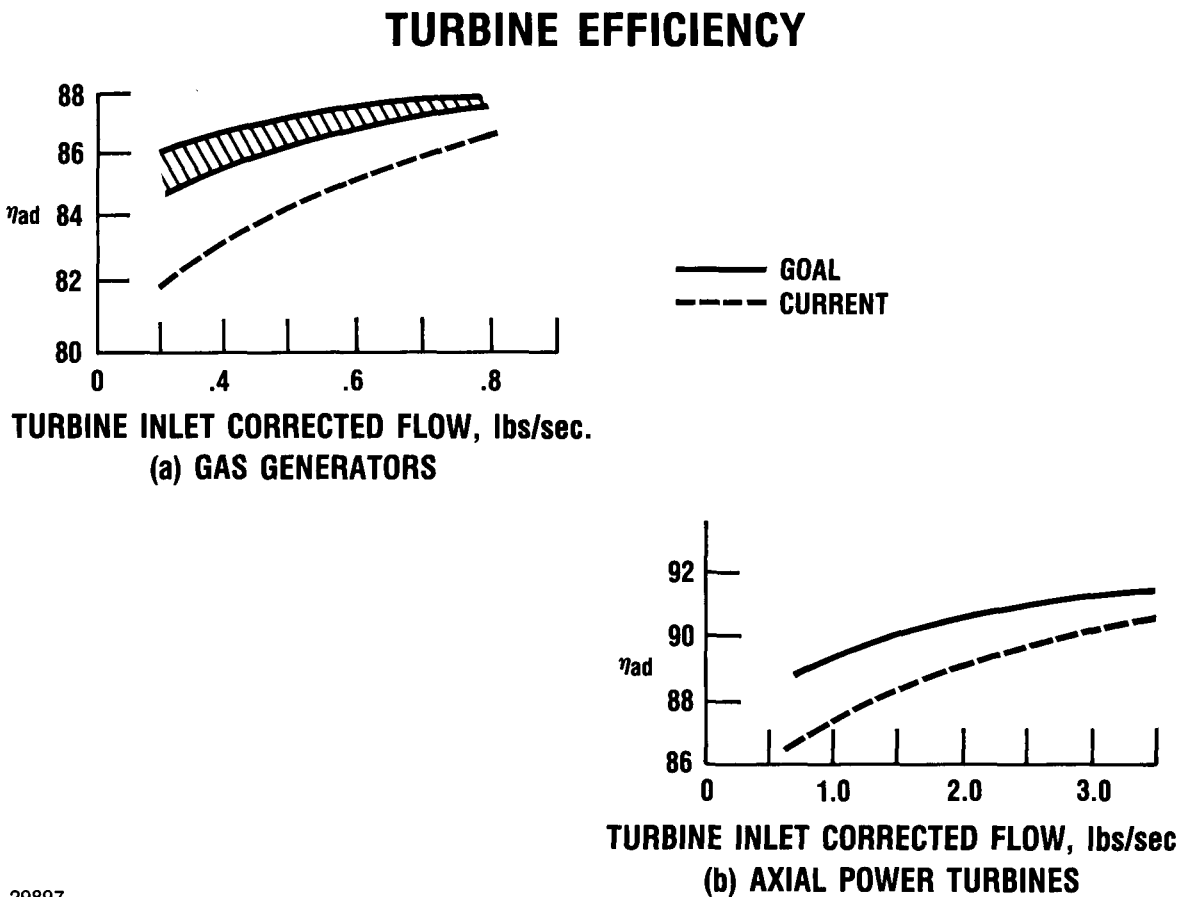

## SMALL TURBINE AERODYNAMICS

This chart displays the principal thrusts of the turbine program. Both axial and radial turbine research are being pursued, with the emphasis on radial turbines. The general approach of identifying, quantifying, and minimizing loss mechanisms (which occur with decreasing size, evolution of improved analytical codes for turbine design, and verification of the improved codes through the implementation of advanced diagnostics) is similar to that described previously for compressors.

# SMALL TURBINE AERODYNAMICS

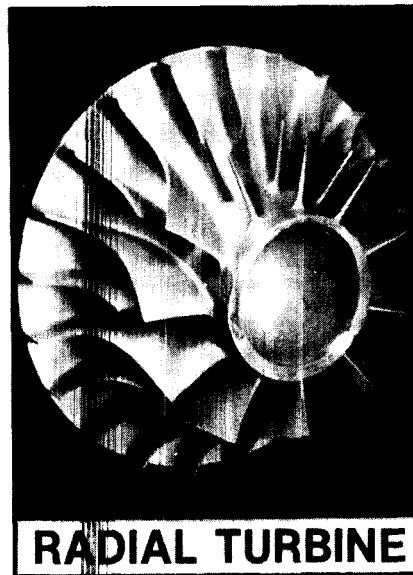
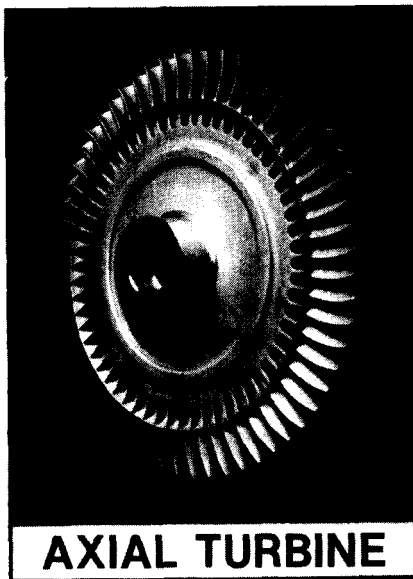

- ENDWALL EFFICIENCY IMPROVEMENT
- LOW ASPECT RATIO AERODYNAMICS
- ENGINE ENVIRONMENT EFFECTS
- SMALL SIZE PENALTIES
- HIGHLY LOADED STAGES
- VARIABLE GEOMETRY
- MANIFOLDS & DUCTS
- COOLING AERODYNAMICS
- VALIDATION OF COMPUTATIONAL METHODS

CD-87-30040

## SMALL TURBINE ENGINE TECHNOLOGY PROGRAM

This chart summarizes progress achieved under a joint NASA/DOE project. The work consisted of an advanced structural analysis code applicable to the design of high-temperature structural ceramic engine components. Currently, the code is in the process of being verified. However, even at this early stage, the code has been applied to radial turbine wheels with the results being used to identify the most promising concepts.

### SMALL TURBINE ENGINE TECHNOLOGY PROGRAM NEW STRUCTURAL ANALYSIS CAPABILITY FOR CERAMIC TURBINE ROTORS (DOE/NASA FUNDED)

- APPLIED, FOR FIRST TIME, A NEW ADVANCED STRUCTURAL ANALYSIS CODE FOR PREDICTION OF FAST FRACTURE FAILURE PROBABILITY OF MONOLITHIC CERAMIC COMPONENTS. THE CODE COMBINES FINITE-ELEMENT STRUCTURAL ANALYSIS CAPABILITY (NASTRAN) WITH WEIBULL STATISTICAL AND FAILURE CRITERIA FROM FRACTURE MECHANICS.

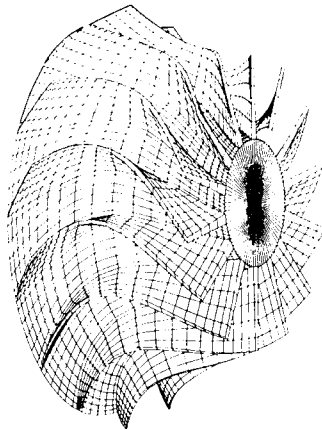

**CERAMIC MIXED FLOW TURBINE**

- COMPLETED THE AERODYNAMIC DESIGN OF HIGH WORK HIGH TEMPERATURE MIXED FLOW TURBINE.
- COMPLETED STRUCTURAL ANALYSIS OF FIRST DESIGN. INDICATED NEED FOR IMPROVED MATERIALS.
- CODE NEEDS FURTHER VALIDATION.

CD-87-29987

**LEWIS IS THE ONLY GOVERNMENT FACILITY WITH AN IN-HOUSE CAPABILITY TO DESIGN CERAMIC COMPONENTS.**

### SMALL WARM TURBINE TEST FACILITY

This modern facility can evaluate the aero and cooling performance of small and medium size axial, radial, or mixed-flow turbines while duplicating all significant similarity parameters. Unique instrumentation includes onboard rotor measurements of pressure and temperature, flow surveys between blade rows during stage operation, and a high speed in-line torque meter. The main facility operating parameters are as follows: inlet temperature, 800 °F; coolant temperature, -50 °F; inlet pressure, 125 psig; flow rate, 10 lbm/sec; speed, 60 000 rpm; and power absorption, 1250 hp.

### SMALL WARM TURBINE TEST FACILITY

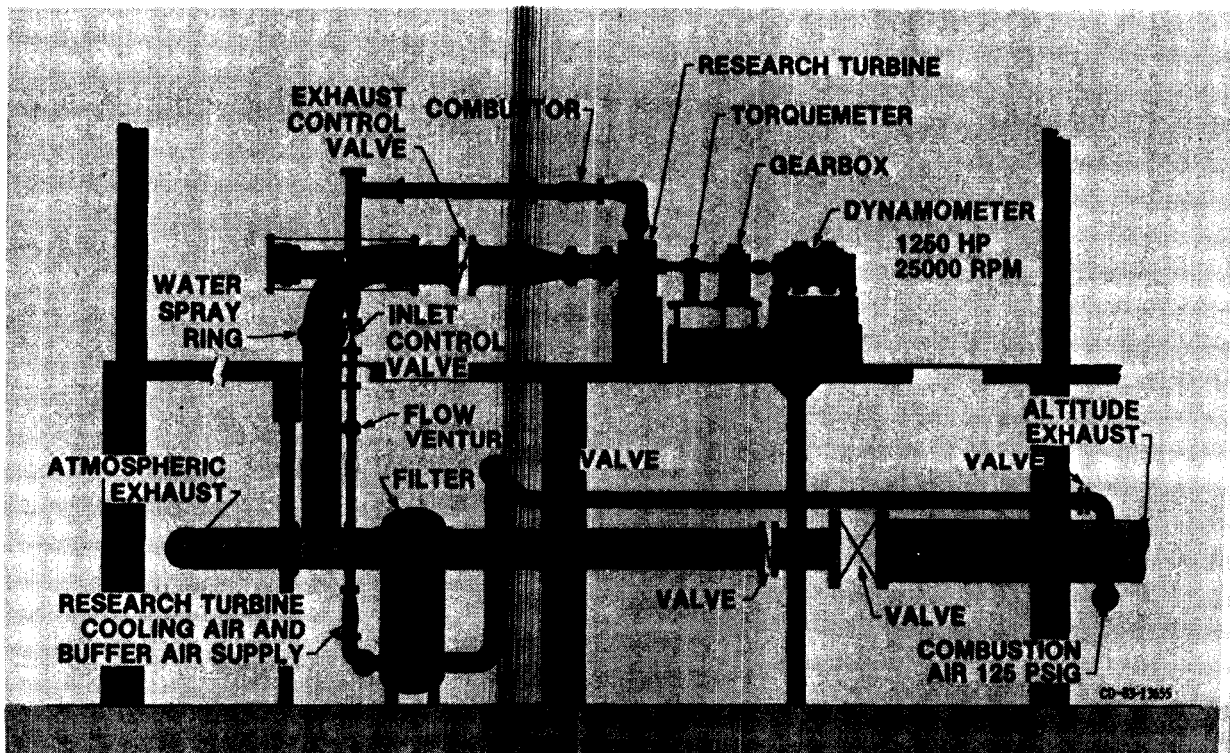

CD-87-29899

## NASA/ALLISON COOLED RADIAL TURBINE

A cooled high temperature radial turbine will be experimentally evaluated in a warm turbine test facility at the NASA Lewis Research Center. The turbine is designed with an uncooled ceramic stator with an inlet temperature of 2500 °F and mass flow of 4.56 lbm/sec. The rotor is designed with 4.5 percent cooling air, a work level of 185 Btu/lbm, and an efficiency of 86 percent. Three-dimensional heat transfer and aerodynamic analyses were performed on the turbine. These predictions will be verified by comparison with experimental results. Detailed measurements of temperature and pressure will be made on the rotor surface and within the cooling channel. Verifying the region of separation along the hub of a radial turbine, and predicting rotor blade temperatures is of particular importance in future turbine designs.

## NASA/ALLISON COOLED RADIAL TURBINE

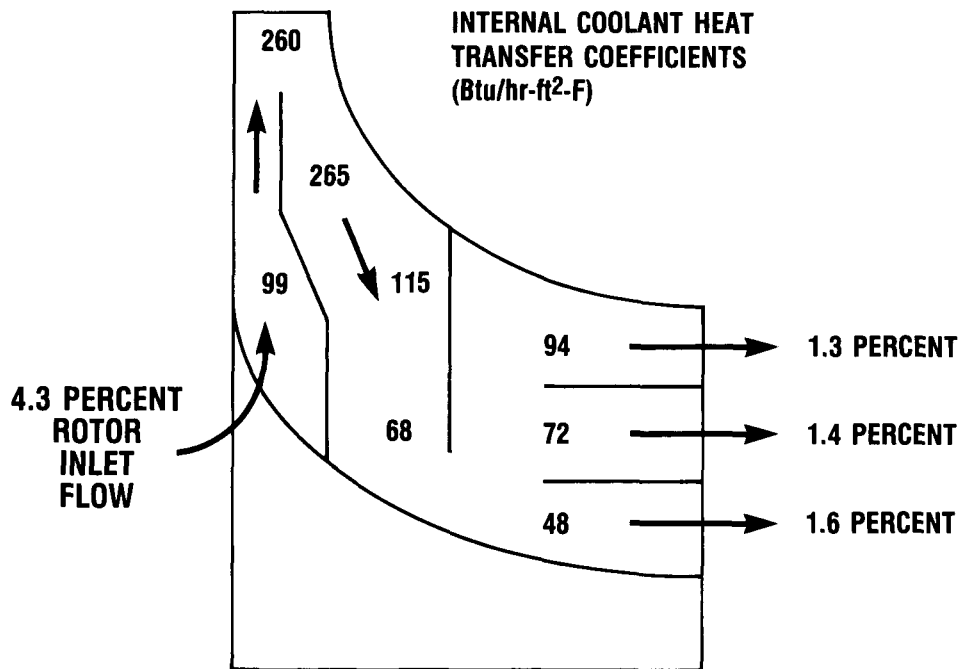

CD-87-29900

## SMALL COMBUSTOR TECHNOLOGY

Small gas turbine combustors currently operate at efficiencies near 100 percent at all landing takeoff cycle operating conditions - efficiency is not a problem. However advanced cycle engines will require increased temperature and pressure capability, reduced air coolant requirements for liners, and increased durability of injectors and liners. The research program in place is addressing all of those needs. Also required will be combustion systems which produce uniform exit temperature distributions - approximately twice the uniformity currently achievable.

Numerous small combustor types are employed. Three are shown on this chart. Axial combustors are scaled down versions of large combustors. Flow proceeds axially through the combustor. Reverse flow combustors are the most common variety. Compressor discharge air exhausts into a plenum which then feeds the various combustor zones according to a preset schedule. This combustor design is popular because it packages well in small engines. However, it also has the greatest amount of hot-section surface area, liners and reverse flow turn, and is thus the most difficult to cool. Radial outflow combustors are reverse flow types but contain several significant differences. They usually increase in volume radially and fuel is injected through the spinning shaft. Thus fuel injectors are not required. This combustor type is used in cruise missile engines.

## SMALL COMBUSTOR TECHNOLOGY

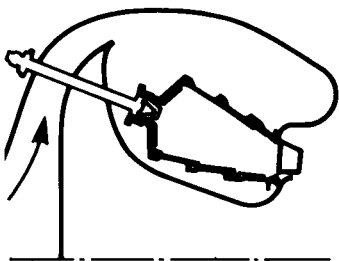

AXIAL FLOW

### TECHNOLOGY NEEDS

- INCREASED TEMP/PRESSURE CAPABILITY
- REDUCED AIR COOLANT REQUIREMENTS
- INCREASED DURABILITY/RELIABILITY



PRIMARY ZONE DESIGN METHODS



ADVANCED LINER COOLING

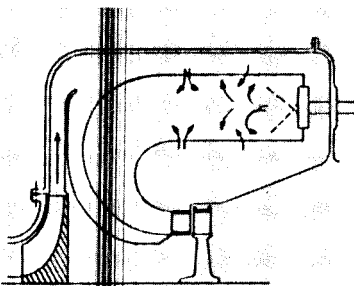

REVERSE FLOW

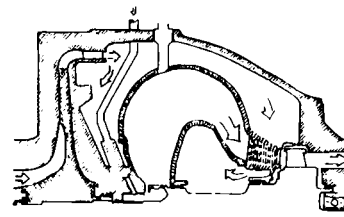

RADIAL OUTFLOW

CD-87-29901

## CERAMIC MATRIX COMBUSTOR LINER

A recent combustion research accomplishment is shown on the figure. An advanced combustor liner, the ceramic matrix, was developed. This combustor utilizes only backside cooling air - no chargeable air injected through the liner is required for keeping the liner within temperature limits. The concept employs a thick ceramic coating impregnated on a pliable felt metal. The pliable metal reduces stresses imposed on the ceramic, and supplies a heat shield to confine combustion temperatures. Short duration performance tests of this concept were conducted to over 2600 °F - 300 to 400 °F hotter than current combustor temperatures. Current activities are underway in-house and under an Army contact to optimize the implementation of this concept.

## CERAMIC MATRIX COMBUSTOR LINER (JOINT NASA/ARMY PROGRAM)

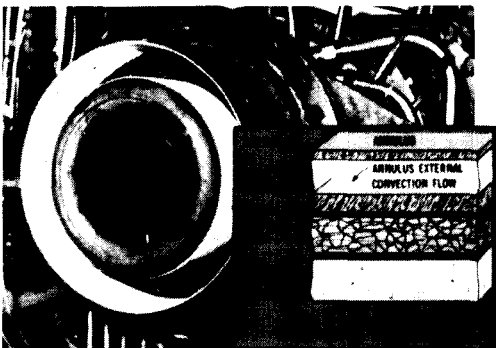

### CERAMIC MATRIX BENEFITS

- SIGNIFICANT PERFORMANCE IMPROVEMENTS EXPERIMENTALLY VERIFIED AT ADVANCED CYCLE CONDITIONS—300 °F HOTTER THAN CURRENT ENGINES
- ADDITIONAL COOLANT NOW AVAILABLE FOR OTHER ENGINE USES

### COMBUSTOR LINER COOLING COMPARISON (SIMULATED 16:1 ENGINE CYCLE)

OBJECTIVE: REDUCE COOLING REQUIREMENTS AND EXTEND LINER LIFE AT HIGHER TEMPERATURES THROUGH USE OF CERAMICS

- CERAMIC THERMAL BARRIER-YTRIA STABILIZED ZIRCONIA WITH COMPLIANT METALLIC BACKING
- METAL SUBSTRATE SUPPORT STRUCTURE
- BACKSIDE CONVECTIVE COOLING ONLY

### LINER COMPARISON (CYCLE 16:1)

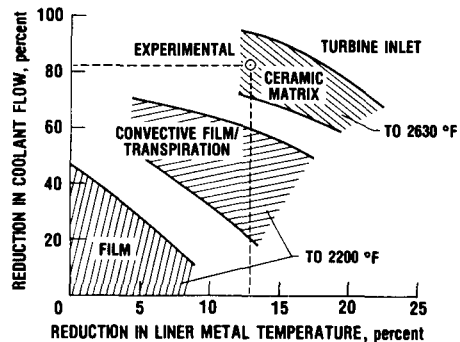

ORIGINAL PAGE IS  
OF POOR QUALITY

DOE/NASA ADVANCED GAS TURBINE TECHNOLOGY

The AGT, automotive gas turbine program, began in 1980. FY 1986 was the final funding year though funds were expended through FY 1987. In FY 1987 a new program was initiated, this will be described later.

## DOE/NASA ADVANCED GAS TURBINE TECHNOLOGY

**OBJECTIVE:**

- DEVELOP A TECHNOLOGY BASE APPLICABLE TO A COMPETITIVE AUTOMOTIVE GAS TURBINE ENGINE

**TECHNOLOGY FOCUS:**

- HIGH TEMPERATURE CERAMIC COMPONENT TECHNOLOGY

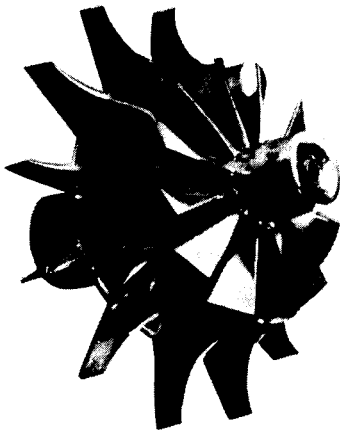
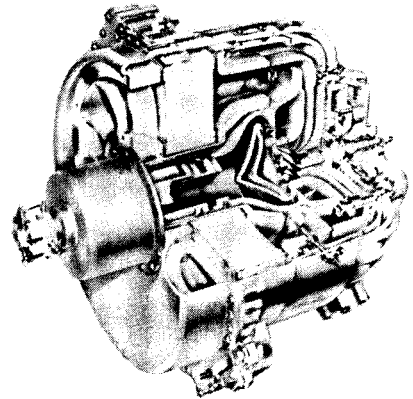

**APPROACH:**

- DEVELOP IMPROVED
  - ANALYTICAL DESIGN TOOLS
  - COMPONENT FABRICATION PROCESSES
  - PROCEDURES FOR EVALUATING CERAMIC COMPONENTS

CD-87-29903



## DOE/NASA ADVANCED GAS TURBINE CERAMIC COMPONENT TECHNOLOGY

This figure illustrates the Allison AGT 100 test bed engine. The engine is regenerated, two-shaft, has a maximum rotor speed to 86 000 rpm and has been operated to 2100 °F for 6 hour.

## DOE/NASA ADVANCED GAS TURBINE CERAMIC COMPONENT TECHNOLOGY

### AGT 100 TEST-BED ENGINE

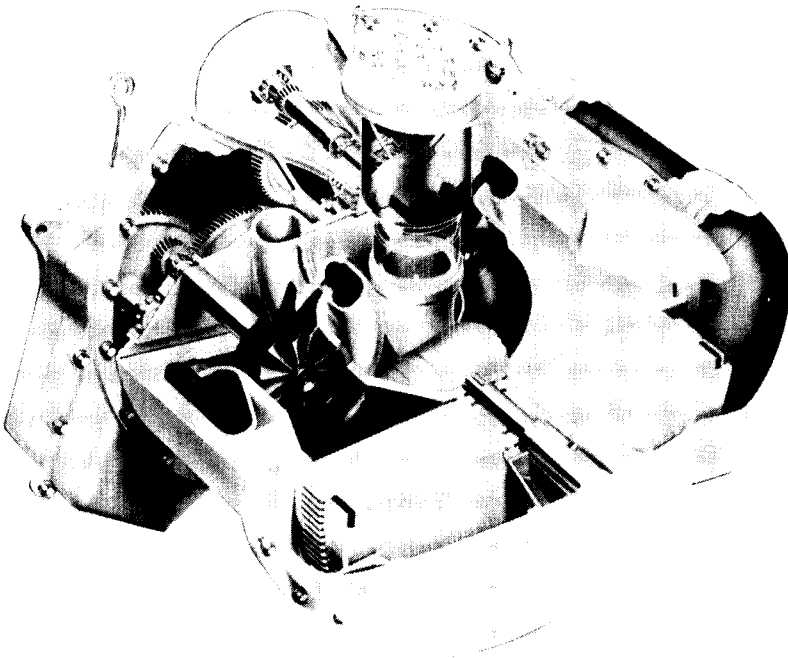

#### DESCRIPTION

- REGENERATED TWO SHAFT
- TURBINE INLET TEMPERATURES UP TO 2350 °F
- MAXIMUM ROTOR SPEED 86,000 RPM

CD-87-29904

ORIGINAL PAGE IS  
OF POOR QUALITY

### AGT 100 CERAMIC COMPONENTS

This figure illustrates the ceramic components incorporated in the Allison engine. Similar components were also fabricated and tested in the Garrett engine.

Ceramic materials used were silicon carbides, silicon nitrides, aluminum silicates and zirconias. Numerous contractors, both U.S. and foreign, were used to supply ceramic parts. Some of the contractors were Standard Oil, Norton, GTE Labs, Airesearch Casting, Corning, Coors, Pure Carbon and AC Spark Plug. Development of new technologies and capabilities has been restricted to U.S. corporations. This approach will be continued in the future. The approach has led to a significant improvement in national production capability. This capability is essential in applying ceramics, of sufficiently high quality, for both automotive and aeronautical missions.

In addition to providing viable alternatives to the automotive industry, much of the technology evolved is also applicable to aeronautical missions. This is especially true of the ceramics and composites research, the analytical design tools, and the component fabrication processes and procedures.

### AGT 100 CERAMIC COMPONENTS

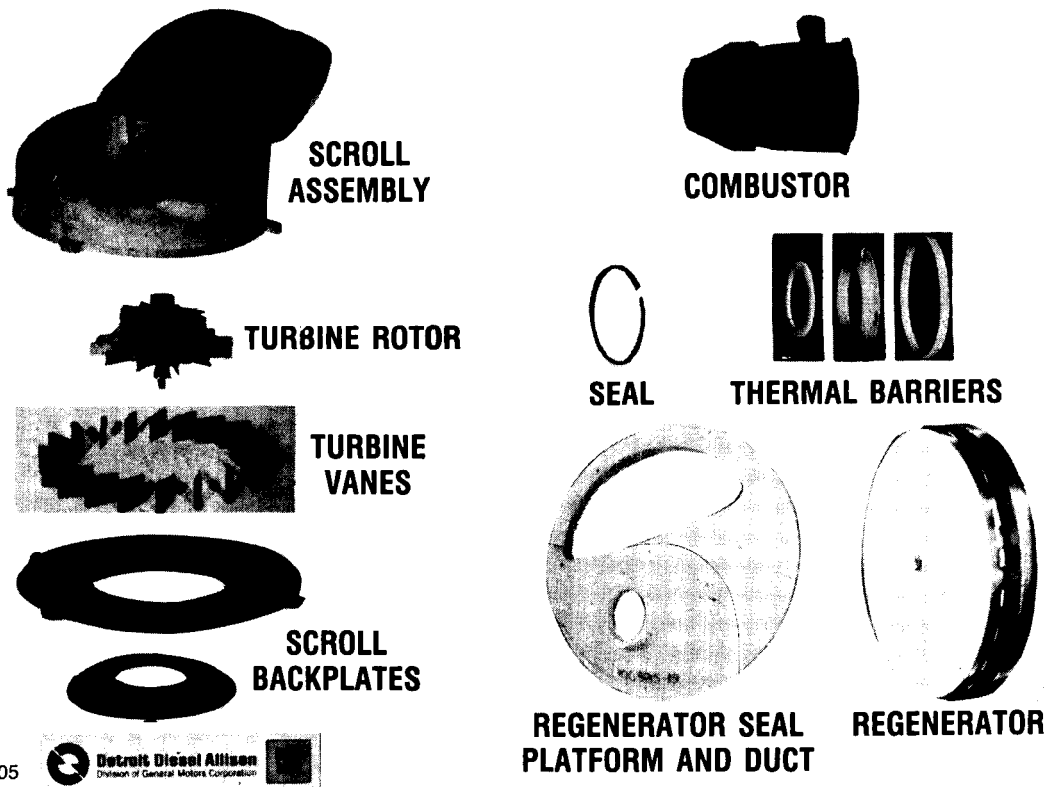

CD-87-29905



## ALL-CERAMIC ENGINE ACCUMULATES 85 HOURS AT 2200 °F

This figure illustrates the Garrett AGT 101 engine. This engine has been operated for 85 hours at 2200 °F. At that point rotor damage was sustain. These results illustrated both the promise of ceramic components as well as the need for future research to develop long-life components.

## ALL-CERAMIC ENGINE ACCUMULATES 85 HOURS AT 2200 °F

- TURBINE INLET TEMPERATURE:  
2000-2200 °F
- OPERATING SPEED:  
60,000-70,000 RPM
- STARTS: 5
- SAME STRUCTURES FROM  
PREVIOUS TEST
- TEST STOPPED DUE TO  
TURBINE ROTOR DAMAGE

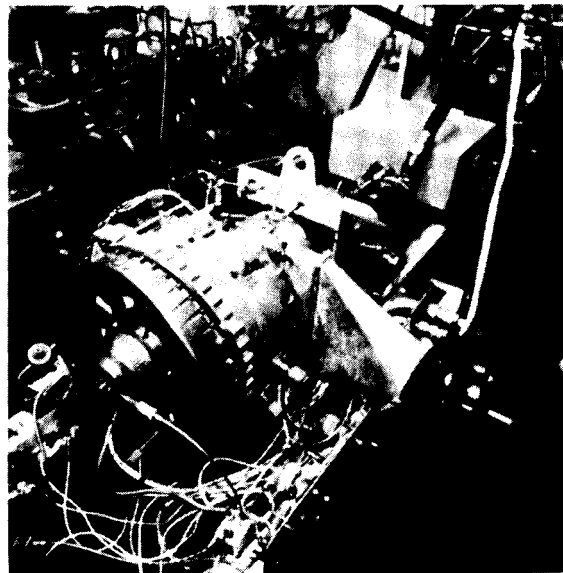

CD-87-29906

ORIGINAL PAGE IS  
OF POOR QUALITY

## ADVANCED TURBINE TECHNOLOGY APPLICATIONS PROJECT - ATTAP

This chart summarizes the FY 1987 new start program - ATTAP. Major technological thrusts of the program will be high temperature structural ceramics, high temperature heat exchangers, low emission combustors, high temperature bearings and small efficient turbomachinery.

## **ADVANCED TURBINE TECHNOLOGY APPLICATIONS PROJECT—ATTAP**

- **NEW START IN FY '87**
- **FOCUS ON CERAMIC TECHNOLOGY DEVELOPMENT**
- **FIVE YEAR COST SHARE CONTRACTS WITH ALLISON AND GARRETT**

**GOAL: TO DEVELOP AND DEMONSTRATE STRUCTURAL CERAMIC COMPONENTS IN AN AUTOMOTIVE TURBINE ENGINE ENVIRONMENT UP TO 2500 °F PEAK TEMPERATURE CONDITIONS.**

## ROTARY ENGINES

The target of the rotary engine program is to improve fuel consumption by 40 percent, reduce engine weight while providing multi-fuel (jet fuel) for general aviation and other small engine aeronautical missions.

Rotary engines offer several advantages over piston engines for small engine aircraft applications. These include:

- (1) They are potentially more fuel efficient
- (2) They are inherently more fuel flexible. Their implementation and operation with jet-A fuel could make aviation gasoline obsolete.

The rotary program contains several elements: It includes large contractual activities with John Deere Co. as well as grant and contracts with MCI, MTU, ADAPCO, Adiabatics, PDA Engineering, and MIT. Understanding the combustion processes, and evolving the technology for advanced combustion systems, is the key to advanced, high-performance rotary engines.

## ROTARY ENGINES

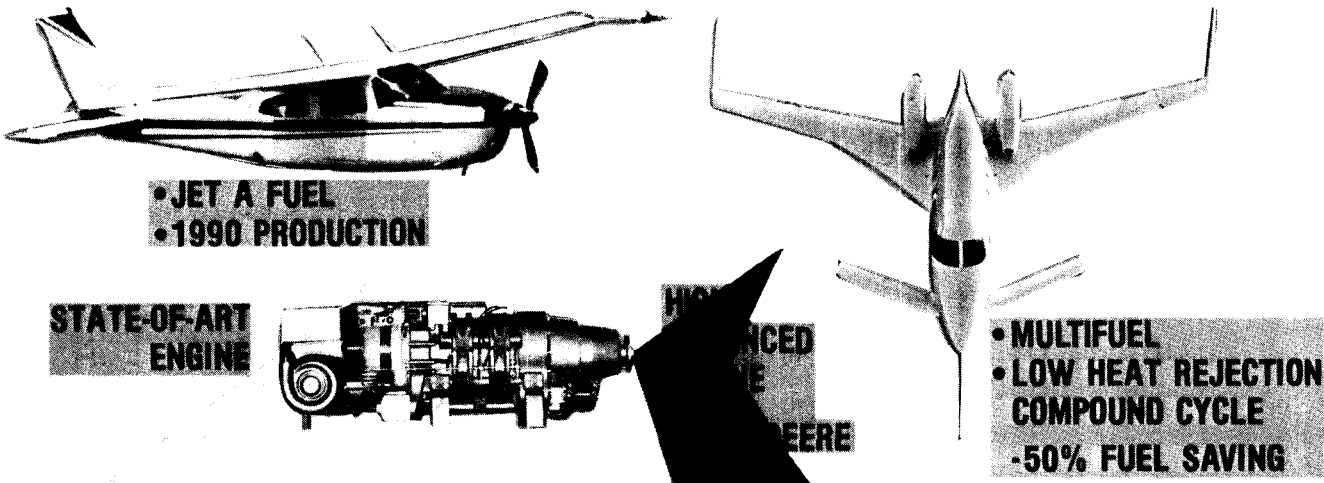

**NASA-INDUSTRY  
TECHNOLOGY  
INVESTMENT**

**PAST AND CURRENT**

### **FUNDAMENTAL R & T**

- COMBUSTION, THERMAL, MECHANICAL MODELS
- VALIDATION OF CODES
- LOW HEAT REJECTION TECHNOLOGY
- TRIBOLOGY AND TURBOCOMPOUNDING

### **TECHNOLOGY ASSESSMENT**

- ADVANCED COMPONENT AND SYSTEMS TESTS

CD-87-29908

## NASA/DEERE STRATIFIED CHARGE ROTARY ENGINE

Advanced fuel efficient rotary engines will require evolution of lightweight rotors and housing, adiabatic components, and turbocompounding. The chart summarizes recent progress and indicates program goals. The parameter used is brake specific fuel consumption.

In 1986, initial test with a high speed electronic fuel control produced BSFC values to 0.51.

In fiscal year 1987, BSFC was reduced to 0.46, this through application of validated combustor cones and optimization of the electronic fuel control system.

The overall BSFC goal is 0.35 at 160 horsepower and 8000 rpm. To achieve this goal turbocompounding, adiabatic components, and a lightweight rotor, with reduced friction, will be required.

## NASA/DEERE STRATIFIED CHARGE ROTARY ENGINE

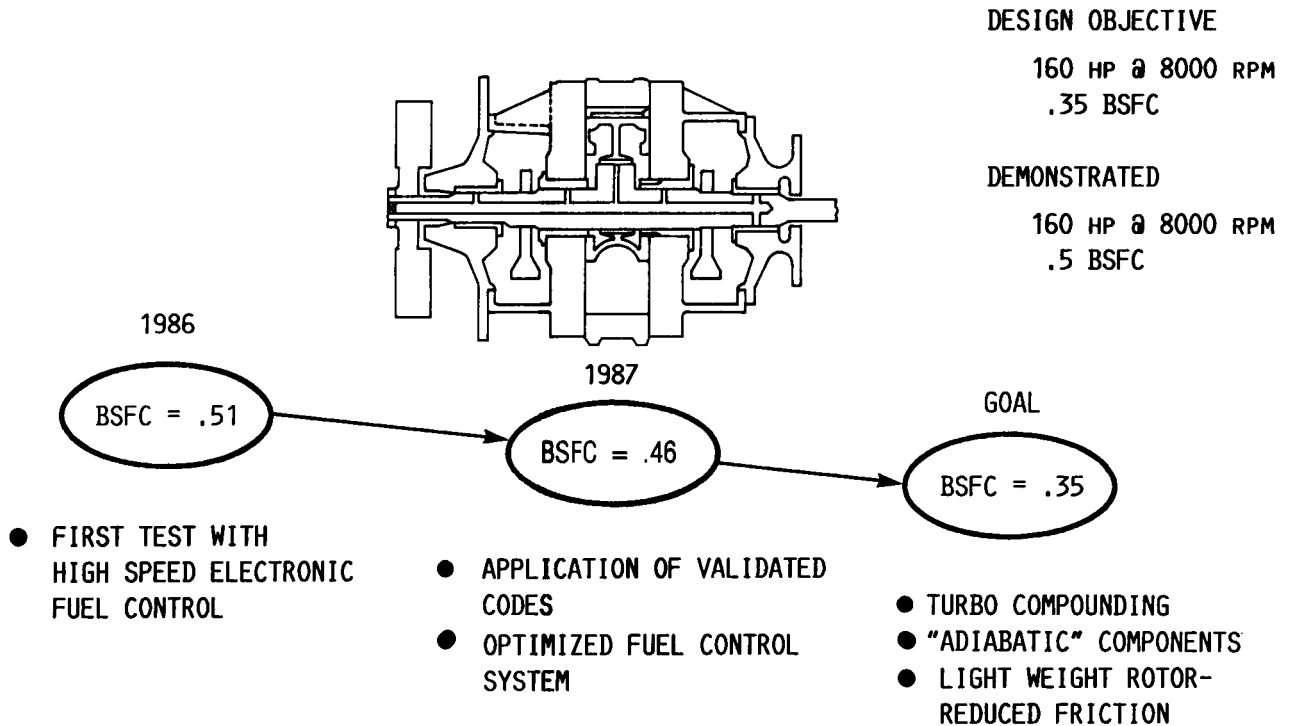

CD-87-29909

## COMPOUND CYCLE ENGINE

The program is planned in three parts:

Part 1. - Currently in progress, is aimed at establishing the technology base for a long-life diesel core. Activities focus on single cylinder diesel research.

Part 2. - Aimed at validating life, minimizing heat rejection losses, optimizing intercylinder dynamics, and verifying diesel performance predictions.

Part 3. - Will demonstrate the integrated turbine/diesel system concept and performance.

## COMPOUND CYCLE ENGINE

**OBJECTIVE: ENLARGE DIESEL TECHNOLOGY BASE FOR WIDE RANGE OF AIR AND LAND VEHICLE APPLICATIONS**

**SIZE RANGE: 500 TO 2000 HP**

**APPROACH:**

- **FOCUS ON HIGH SPEED AND HIGH PRESSURE TO REDUCE SIZE**
- **RESUME PREVIOUS DARPA-SPONSORED PROGRAM WITH GARRETT**
- **BROADEN PROGRAM TO INCLUDE MORE OF ENGINE INDUSTRY**
- **ESTABLISH BASE FOR DEMONSTRATOR**

**EXPECTED RESULT:**

- **FUEL SAVINGS OF 40 PERCENT**
- **COMPACT, COMPOUND CYCLE**
- **BROAD APPLICATIONS**



**HELICOPTER  
FIXED WING/PROPELLOR  
TILT ROTOR**

**HIGH MOBILITY VEHICLE  
LANDING CRAFT  
AIR CUSHIONED VEHICLE**

CD-87-29910

ORIGINAL PAGE IS  
OF POOR QUALITY

## COMPOUND CYCLE ENGINE

Since the program is in its initial phases, no engine currently exists. This is a sketch illustrating main features of an application of the technology. It is anticipated that the gas turbine components technologies will be available from the small gas turbine program. The flow diagram illustrates the features of the integrated cycle.

Planned operation is as follows: Flow goes into the compressor (10.6:1) and through an aftercooler. The aftercooler reduces the air temperature to the cylinder thus lowering ring reversal and exhaust valve temperatures. (Most importantly, it will enhance life.) The exhaust from the diesel cylinder then goes to the gas generator and power turbines. Approximately one-fourth of the power is generated by the turbo-machinery and three-fourths by the diesel.

## COMPOUND CYCLE ENGINE

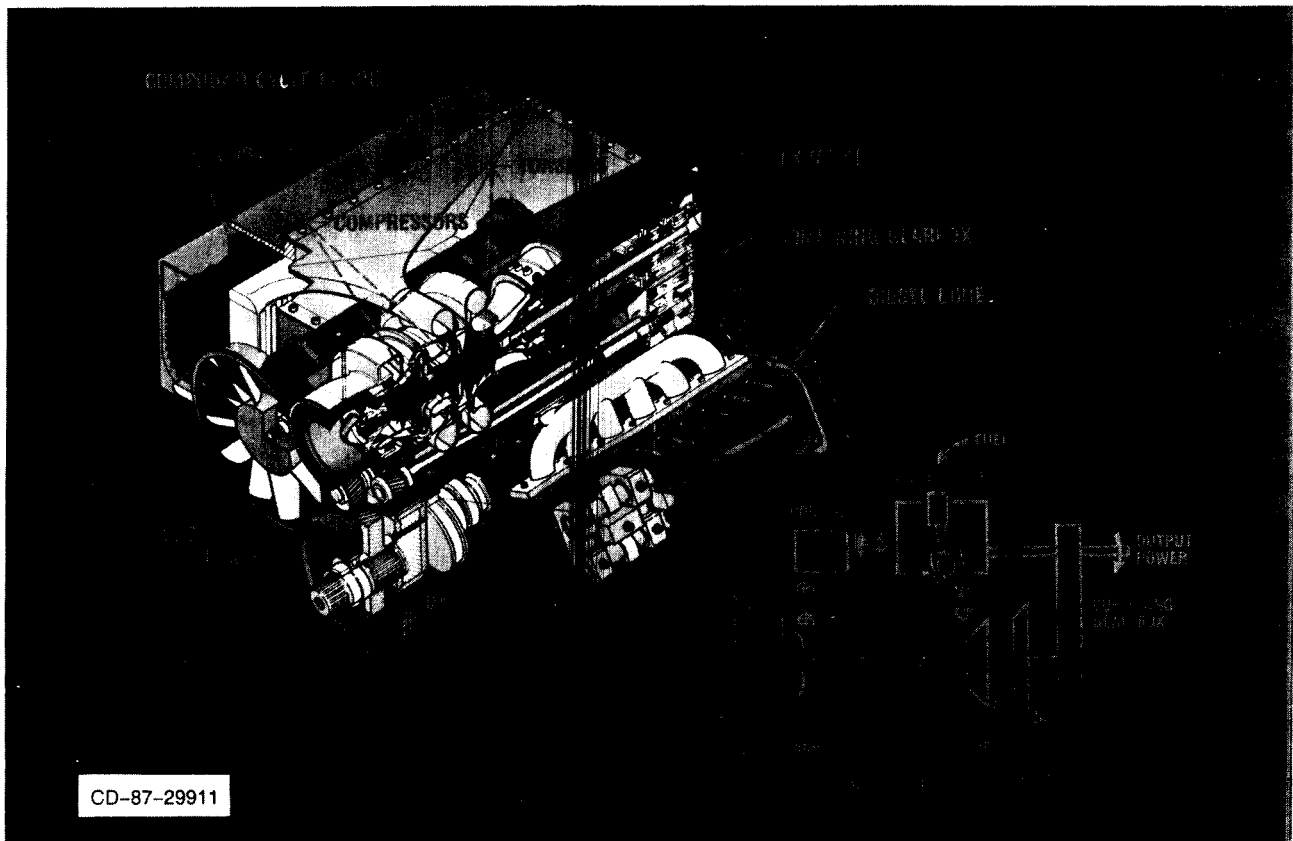



DOE/NASA HEAVY DUTY TRANSPORT TECHNOLOGY PROJECT

This program is DOE funded and technically managed by NASA. Program activities are being performed almost entirely under grant and contract.

Key problem areas requiring research are exhaust gas heat recovery, adequate piston seals, low emission performance, engine friction and wear and thermal insulation implementation.

There exists much synergism between this program and the aeronautics programs - especially the Compound Cycle Engine Program. Areas where much technology transfer is expected to occur are as follows:

(1) Thermal barrier coatings for heavy duty diesel engines. Preliminary results indicate that plasma sprayed coatings are viable alternatives to monolithic ceramics for in-cylinder insulation in the adiabatic diesel of the future.

(2) Evolution of piston ring/cylinder liner materials for advanced diesel engines. Ten candidate materials have been evaluated to date. Of those, K-162B and TIC had the lowest wear rates. They generated psuedo-lubricants. While K-162B had the lowest dynamic friction coefficient.

**OBJECTIVE:**  
**DEVELOP A TECHNOLOGY BASE APPLICABLE TO THE  
ADVANCED "ADIABATIC" DIESEL ENGINE OF THE FUTURE**

- GOALS:**
- FUEL ECONOMY**
  - 30% IMPROVEMENT OVER CONVENTIONAL  
DIESEL ENGINES**
  - ECONOMIC & SOCIAL ACCEPTANCE**
  - COMPETITIVE CAPITAL & MAINTENANCE COSTS**
  - MEET NOISE & EMISSIONS STANDARDS**
  - FUEL TOLERANCE**

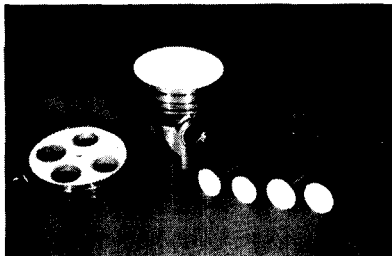
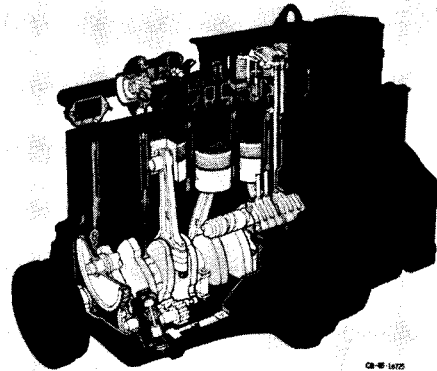

- APPROACH:**
- ELIMINATE WATER COOLING**
  - CERAMIC INSULATING MATERIALS**
  - HIGH TEMPERATURE TRIBOLOGY**
  - WEAR COATINGS, PISTON SEALS, LUBRICATION**
  - EXHAUST GAS HEAT RECOVERY**
  - ADVANCED TURBOCOMPOUND, BOTTOMING CYCLE**

## SMALL ENGINE RESEARCH SUMMARY

In summary, I've described a number of small engine programs being conducted at the Lewis Research Center.

Although each of these programs have specific objectives, there is a strong element of synergism between the various programs in several respects. All of the programs will or presently include research in high temperature structural ceramics. This research tends to be generic in nature and has broad applications. The HDTT, the rotary technology and the CCTD are all examining approaches to minimum heat rejection, or "adiabatic" systems employing advanced materials. The AGT program is also directed towards ceramics application to gas turbine hot-section components. Turbo-machinery advances in the gas turbine programs will benefit advanced turbochargers and turbocompounders for the I.C. systems, and the fundamental understandings and analytical codes developed in the R&T programs will be directly applicable to the system projects.

## SMALL ENGINE RESEARCH—SUMMARY

**A/C RESEARCH  
NASA/ARMY**

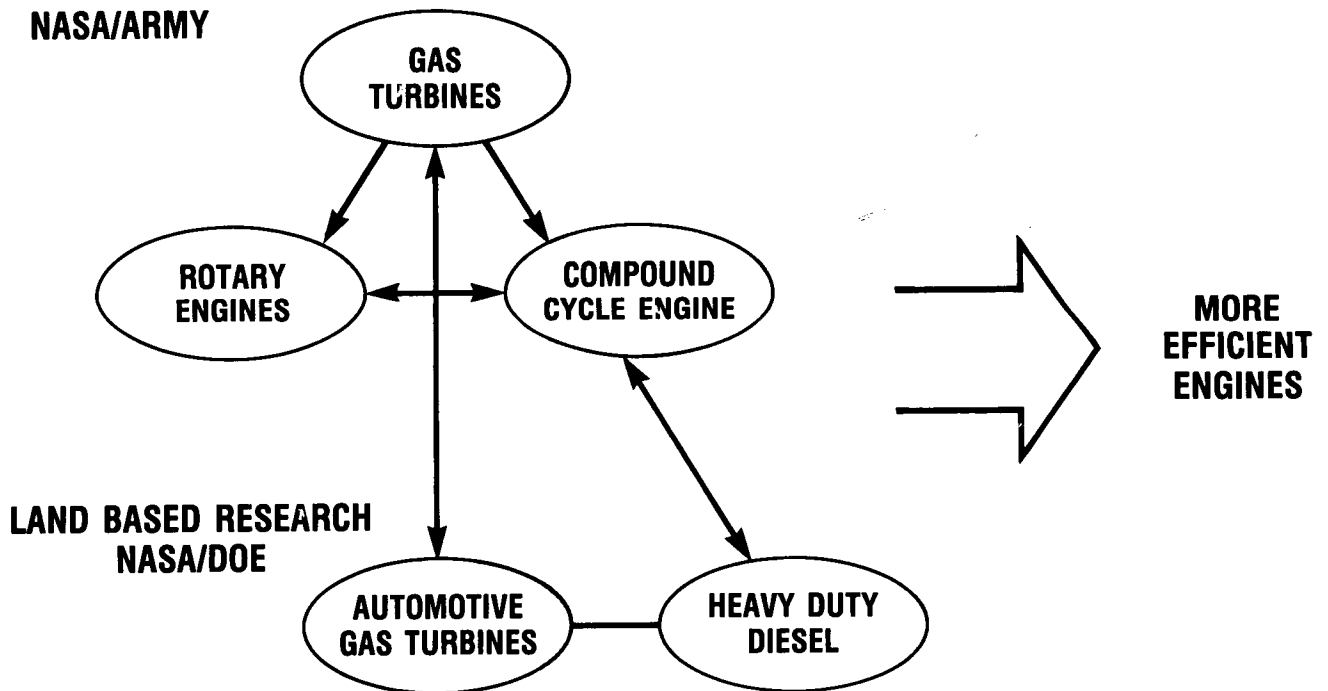

CD-87-29915

N88-15802

52-37  
118877  
98

**ROTORCRAFT TRANSMISSIONS**

John J. Coy

**ABSTRACT**

The NASA Lewis Research Center and the U.S. Army Aviation Systems Command share an interest in advancing the technology for helicopter propulsion systems. In particular, this presentation outlines that portion of the program that applies to the drive train and its various mechanical components. The major goals of the program are to increase the life, reliability, and maintainability; reduce the weight, noise, and vibration; and maintain the relatively high mechanical efficiency of the gear train. The current activity emphasizes noise reduction technology and analytical code development followed by experimental verification. Selected significant advances in technology for transmissions are reviewed, including advanced configurations and new analytical tools. Finally, the plan for transmission research in the future is presented.

**PRECEDING PAGE BLANK NOT FILMED**

## TRANSMISSIONS TECHNOLOGY REQUIRED FOR 1990's

The major goals of the program are to increase the power-to-weight ratio, increase the reliability, and reduce the noise.

# TRANSMISSIONS TECHNOLOGY REQUIRED FOR 1990's

REQUIREMENT	GOAL	BENEFIT
LIGHTER STRONGER	DRIVE TRAIN SPECIFIC WEIGHT 0.3 TO 0.5 lb/hp (CURRENTLY 0.4 TO 0.6 lb/hp)	INCREASED RANGE AND PAYLOAD
MORE RELIABLE	5000-hr MEAN TIME BETWEEN OVERHAULS (MTBO) (CURRENTLY 500 TO 2000 hrs)	LOWER OPERATING COST AND SAFER OPERATION
QUIETER	70 TO 80 dB IN CABIN (CURRENTLY 100 TO 110 dB)	GREATER USE FOR COMMER- CIAL COMMUTER SERVICE  INCREASED PASSENGER AND PILOT COMFORT

CD-87-28719

## CURRENT RESEARCH ACTIVITY IN TRANSMISSIONS

The current activity emphasizes analytical code development and validation, with emphasis on noise reduction technology for drive systems.

Based on the experimental, analytical, and design studies conducted under the transmission technology program, some advanced transmission concepts were evolved, including the advanced 500-hp transmission, the bearingless planetary transmission, and the split-torque transmission.

An extensive data base has been established for two sizes of helicopter transmissions.

## CURRENT RESEARCH ACTIVITY IN TRANSMISSIONS

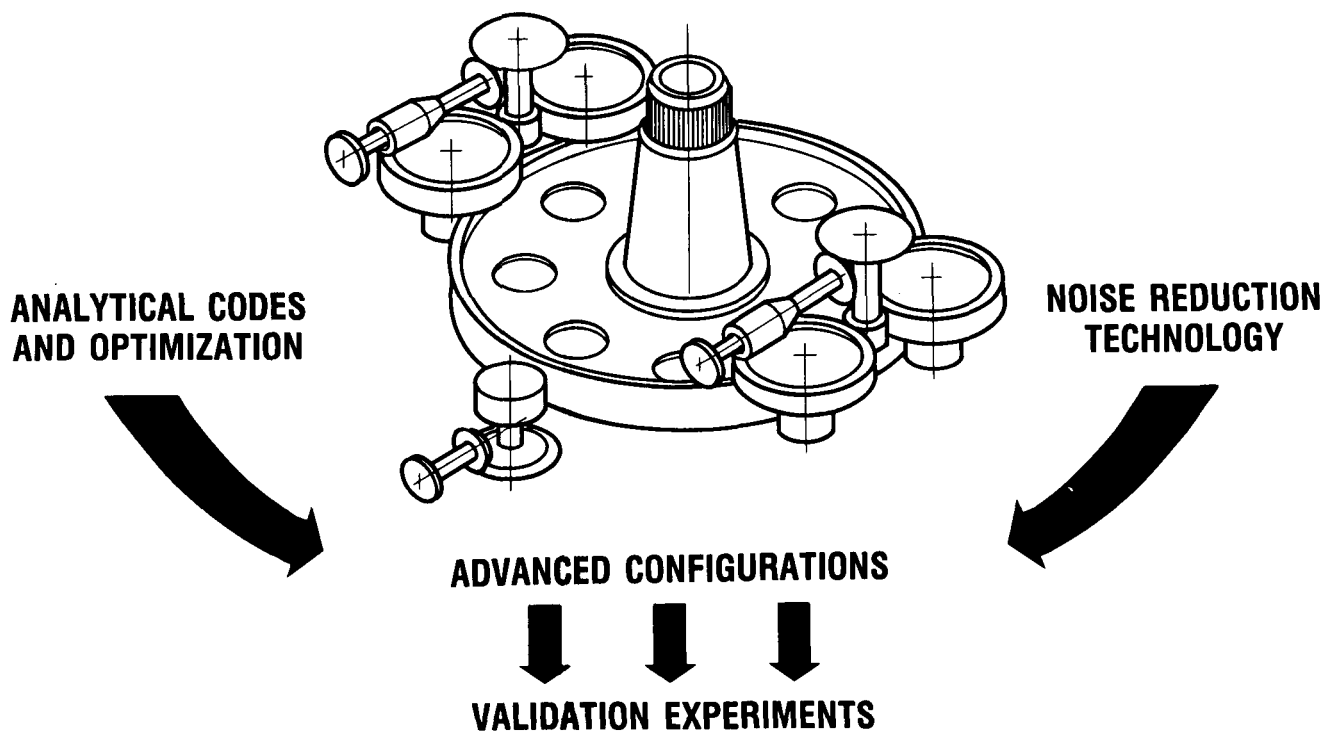

CD-87-28720

COMPREHENSIVE TRANSMISSION MODELING AND ANALYSIS SYSTEM

An in-house and university grant effort continues to develop computer programs for analysis and design of transmission systems. The unique facilities and hardware at Lewis are being used to validate the computer codes and to collect additional data for use in developing the codes. A library of computer codes and subroutines for transmission system analysis is being assembled. The goal is to develop a comprehensive computer program library for transmission system modeling.

COMPREHENSIVE TRANSMISSION MODELING AND ANALYSIS SYSTEM

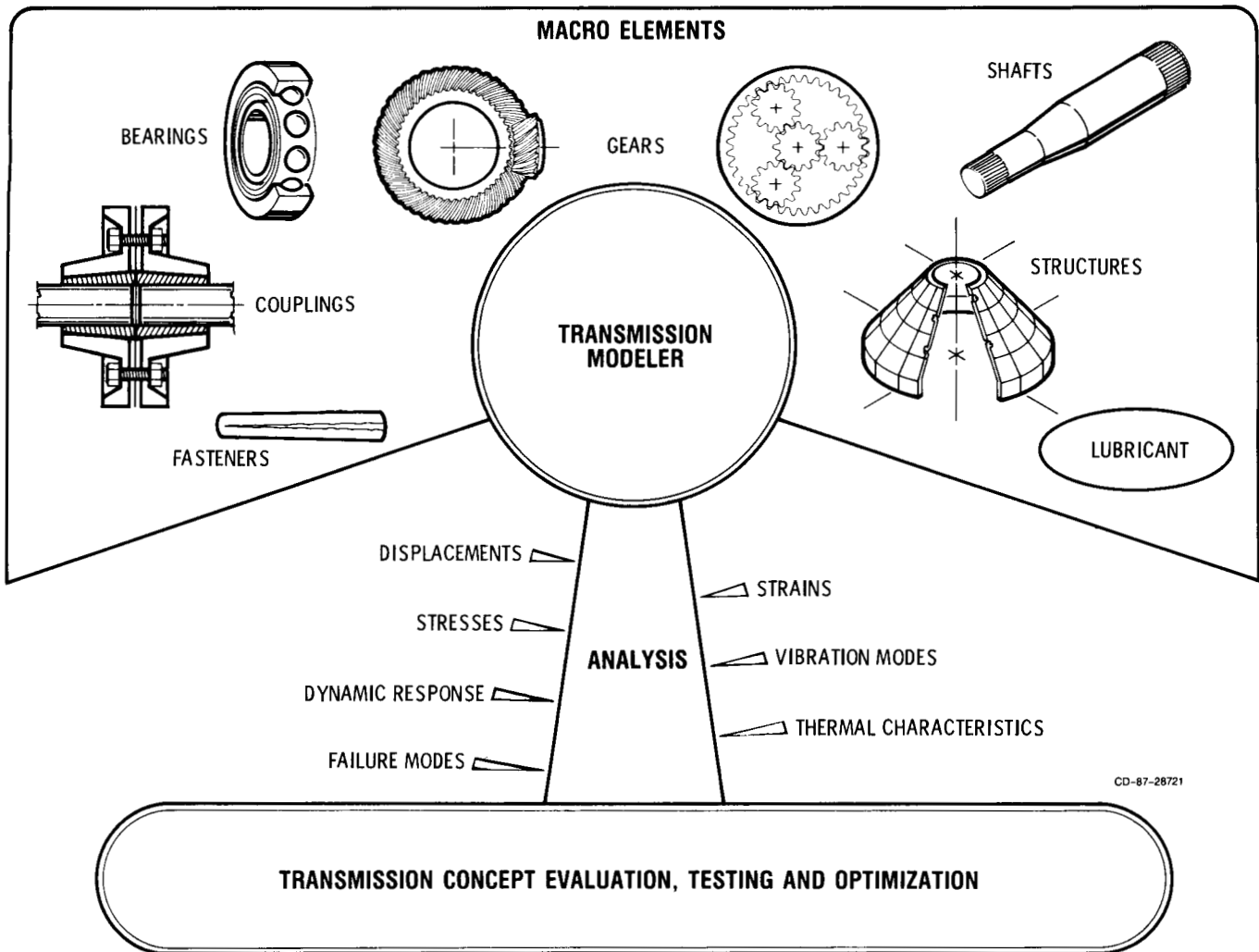

## HELICOPTER TRANSMISSION LIFE AND RELIABILITY COMPUTER PROGRAM

Drive system life and reliability are important issues during the design, development, and field operation of helicopters. Analytical tools are needed for design and for comparing competing and alternate designs.

To meet this need, a versatile computer program was developed to predict helicopter transmission life. The program predicts mean time between failures (MTBF) and can be used to evaluate proposed new designs and to project spare parts requirements for helicopter fleet operations.

## HELICOPTER TRANSMISSION LIFE AND RELIABILITY COMPUTER PROGRAM

### SIGNIFICANCE:

- **VERSATILE COMPUTER PROGRAM FOR PREDICTING TRANSMISSION LIFE AND RELIABILITY**
- **TOOL FOR EVALUATING PRELIMINARY AND COMPETING DESIGNS**
- **PROVIDES INFORMATION THAT CAN BE USED TO PLAN SPARE PARTS REQUIRED**

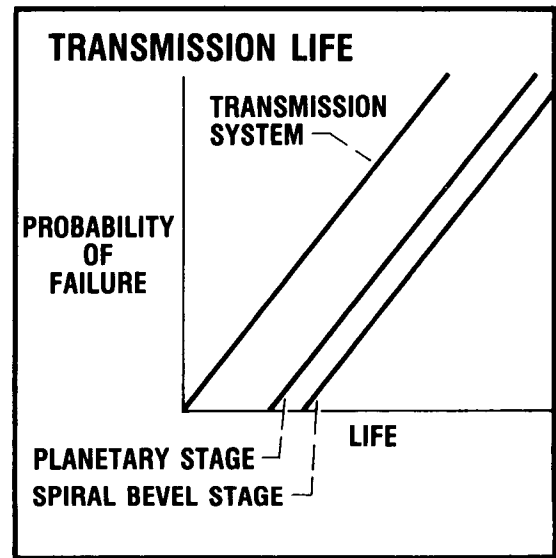
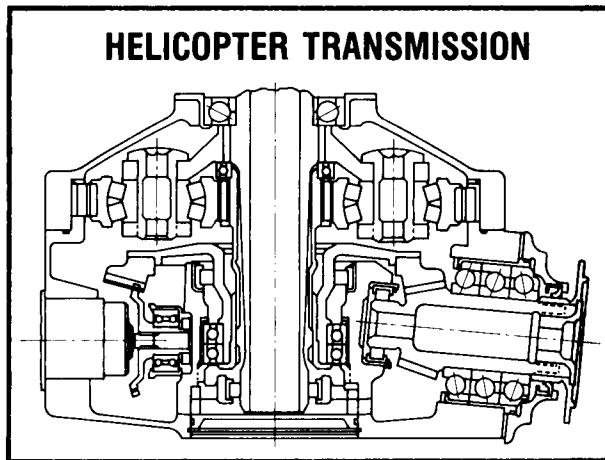

### FEATURES:

- **INPUTS: TRANSMISSION CONFIGURATION, LOAD, AND SPEED**
- **OUTPUTS: TRANSMISSION COMPONENTS AND SYSTEM LIVES**

CD-87-28722

## TRANSMISSION NOISE REDUCTION TECHNOLOGY FOR ROTORCRAFT

Historically, helicopters have been plagued by internal noise problems. The transmission is a particularly troublesome source and is believed to be the main source of annoying noise in the helicopter cabin. The noise from the transmission enters the cabin by two paths, structure-borne radiation and direct radiation.

The major portion of our program in transmissions is devoted to finding solutions to this problem.

## TRANSMISSION NOISE REDUCTION TECHNOLOGY FOR ROTORCRAFT

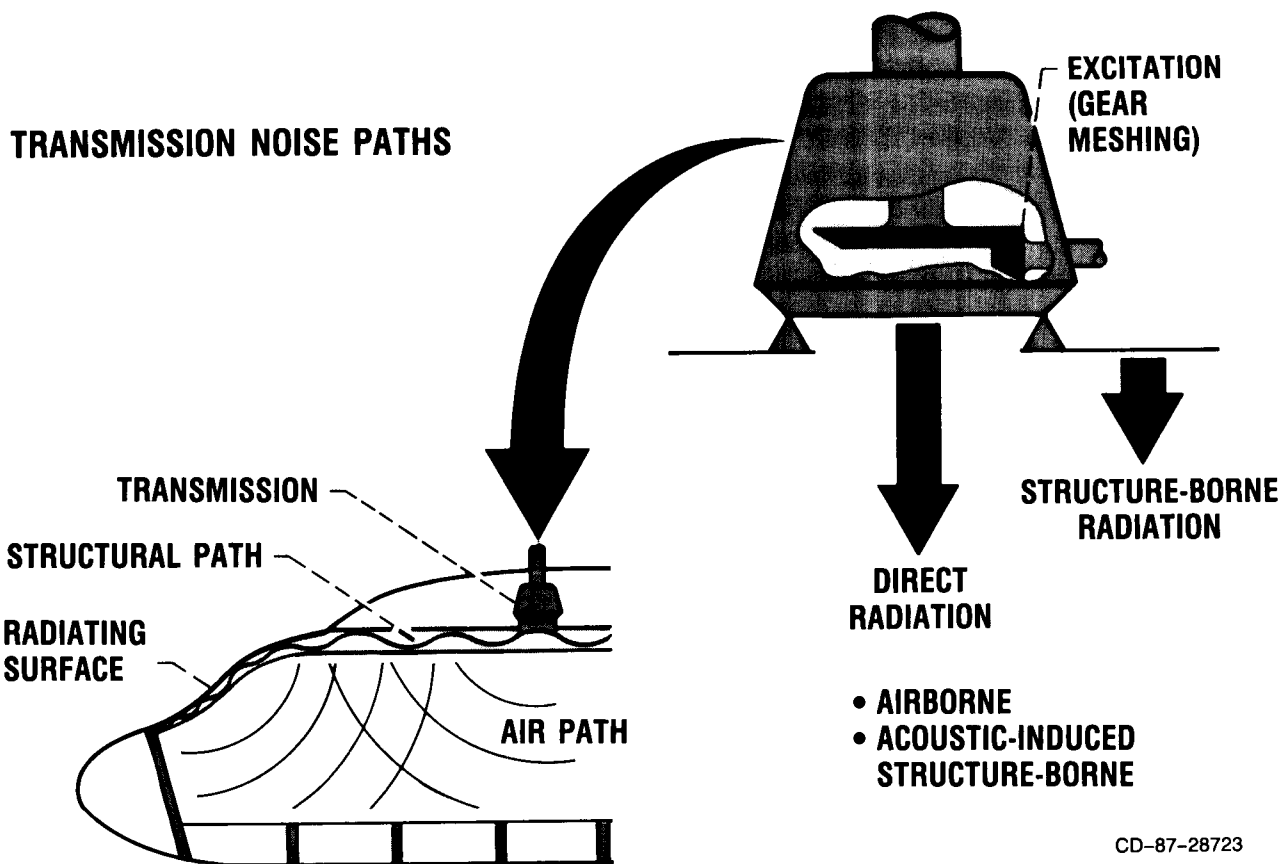



Spiral bevel gears are used in helicopters to transmit power "around the corner" from a horizontal engine output shaft to the vertical rotor shaft. Vibration from spiral bevel gears is a strong source of transmission noise.

The goal of a recent study was to relate gear noise to dimensional and physical factors of the gears. The work completed (1) provides the first detailed mathematical understanding of generalized transmission error in spiral bevel gears, (2) allows prediction of vibration excitation based on gear tooth measurements, and (3) relates gear noise to physical design parameters and therefore provides a basis for future improvements in spiral bevel gear design.

## SPIRAL BEVEL GEAR NOISE MODELING

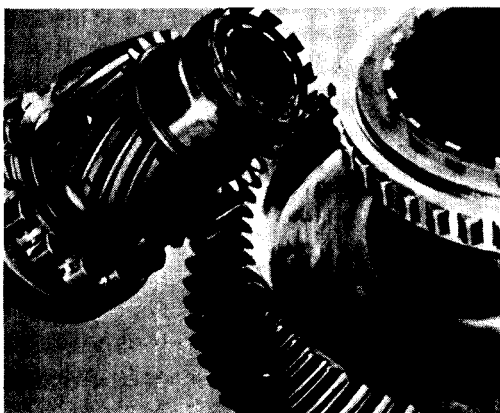
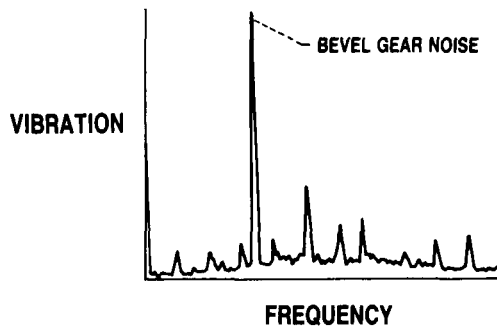

**SPIRAL BEVEL GEARS**

### MILESTONES COMPLETED:

- MATHEMATICAL MODEL OF ZONE OF TOOTH CONTACT FOR SPIRAL BEVEL GEARS
- NEW UNDERSTANDING OF THREE-DIMENSIONAL NATURE OF TOOTH MESHING
- TIME AND FREQUENCY DOMAIN ANALYSIS FOR NOISE EXCITATION FUNCTION
- NASA CR 4081

### SIGNIFICANCE:

- ALLOWS PREDICTION OF VIBRATION FROM GEAR MEASUREMENTS
- PROVIDES BASIS FOR FUTURE IMPROVEMENTS IN SPIRAL BEVEL GEAR DESIGN

**ORIGINAL PAGE IS  
OF POOR QUALITY**

**ADVANCED TRANSMISSIONS**

This chart shows some of the advanced transmissions and concepts that are being studied.

The fundamental concept of the split-torque design is that the power from the engine is divided into two parallel paths prior to recombination on a single gear that drives the output shaft. Studies have shown that replacement of the planetary gear reduction stage with a split torque results in weight savings and increased reliability. The advantage of the split-torque transmission over the planetary transmission is greatest for the larger sized helicopters.

The improved 500-hp design has a weight-to-horsepower ratio of 0.26 lb/hp, compared to 0.37 lb/hp for the 317-hp OH-58C transmission. This transmission is the basis for the transmission in the Army's improved OH-58D model helicopter.

The self-aligning, bearingless planetary (SABP) transmission utilizes a sun gear, planet spindle assemblies, ring gears, and rolling rings. This design projects a weight savings of 17 to 30 percent and a reliability improvement factor of 2:1 over the standard transmission.

**ADVANCED TRANSMISSIONS**

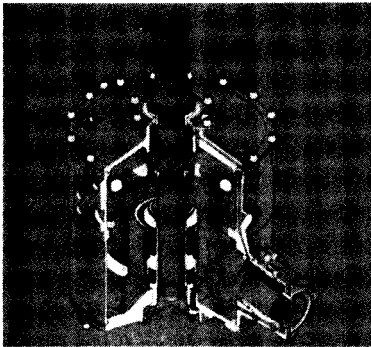

**500-hp BEARINGLESS PLANETARY  
(LOW-RATIO)**

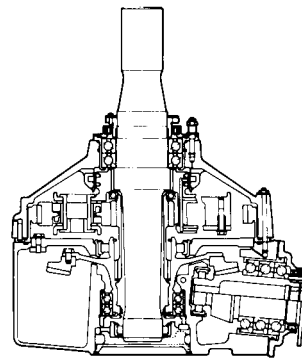

**500-hp/ADVANCED COMPONENTS**

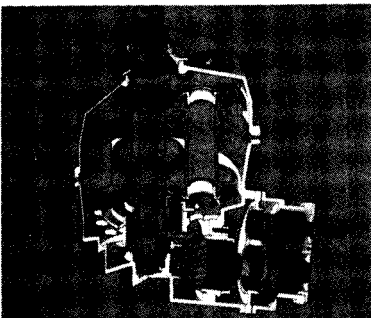

**500-hp BEARINGLESS PLANETARY  
(HIGH-RATIO)**

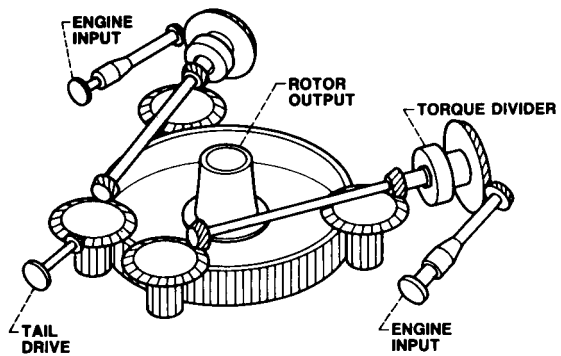

**3600-hp SPLIT TORQUE**

CD-87-28725

# FUTURE THRUST

The plan for future NASA/Army transmission research calls for increased emphasis on noise reduction, an aggressive development of computer-aided design codes for transmissions, and the design and construction of demonstrator transmissions in large and small size categories.

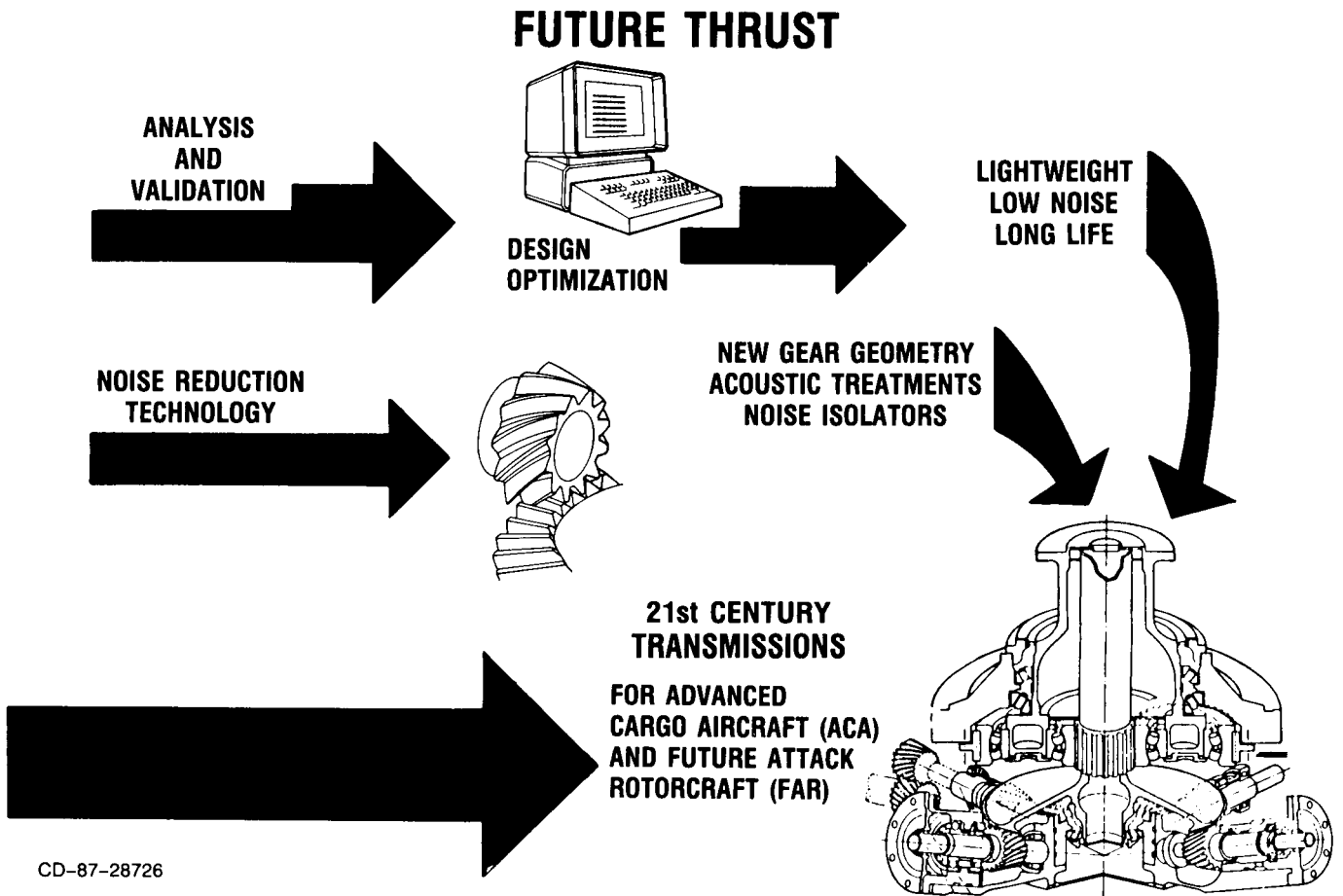

CD-87-28726

N88-15803

53-03  
118838  
271.

The NASA Aircraft Icing Research Program

Robert J. Shaw  
and  
John J. Reinmann

ABSTRACT

The objective of the NASA aircraft icing research program is to develop and make available to industry icing technology to support the needs and requirements for all weather aircraft designs. Research is being done for both fixed and rotary wing applications. The NASA program emphasizes technology development in two key areas: advanced ice protection concepts and icing simulation (analytical and experimental). This paper reviews the computer code development/validation, icing wind tunnel testing, and icing flight testing efforts which have been conducted to support the icing technology development.

PRECEDING PAGE BLANK NOT FILMED

## AIRCRAFT ICING TECHNOLOGY PROGRAM

The icing research program can be viewed to have a generic portion which is devoted to developing fundamental technology. This basic technology is applied with appropriate alterations and modifications to fixed wing and rotorcraft applications to develop more vehicle specific icing technology.

## AIRCRAFT ICING TECHNOLOGY PROGRAM

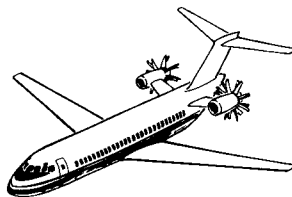
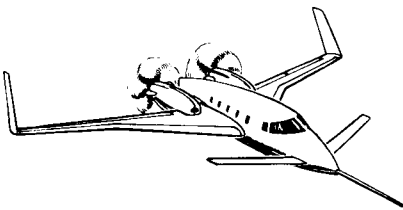

- ICING EFFECTS SIMULATIONS
- ICING FLIGHT TESTS
- ICE PROTECTION CONCEPTS
- TEST TECHNIQUES



**FIXED WING**

**GENERIC**

**ROTARY WING**

- ANALYSIS CODES
- PHYSICS OF ICING
- ICING INSTRUMENTATION
- TEST TECHNIQUES
- ICE PREVENTION/REMOVAL CONCEPTS

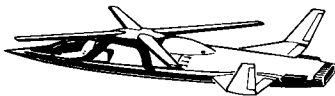

- ICING EFFECTS SIMULATIONS
- ICING FLIGHT TESTS
- ROTOR ICE PROTECTION CONCEPTS
- ROTOR ICING TEST TECHNIQUES

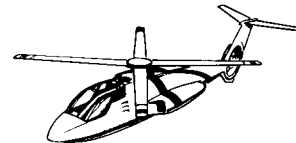

CD-87-28729

ORIGINAL PAGE IS  
OF POOR QUALITY

## ICING RESEARCH

The icing research program is a balanced effort in that it contains analysis code development/validation, wind tunnel testing, and icing flight research activities.

## ICING RESEARCH

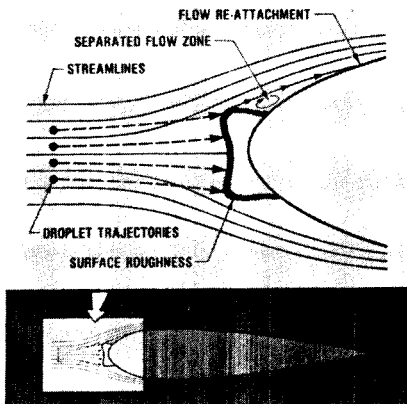

ANALYSIS

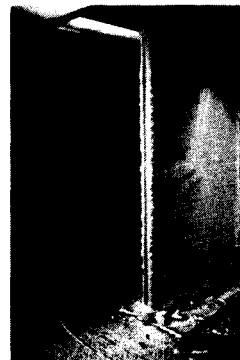

WIND TUNNEL  
TESTING

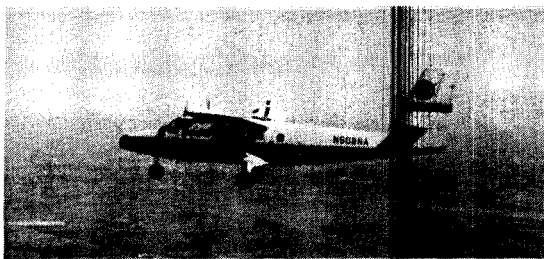

FLIGHT RESEARCH

CD-87-28730

ICE PROTECTION CONCEPTS

## **ICE PROTECTION CONCEPTS**

- **LIGHTER, MORE EFFICIENT SYSTEMS FOR ADVANCED MILITARY AND CIVILIAN AIRCRAFT**

CD-87-30307

## NASA ELECTROMAGNETIC IMPULSE DEICER PROGRAM

The major steps in the multi-year NASA/industry/university program to develop the required technology data base for the electromagnetic impulse deicer (EIDI) are shown. This EIDI technology now available allows manufacturers of both general aviation and commercial transport aircraft to consider EIDI for future aircraft designs.

## NASA ELECTROMAGNETIC IMPULSE DEICER PROGRAM

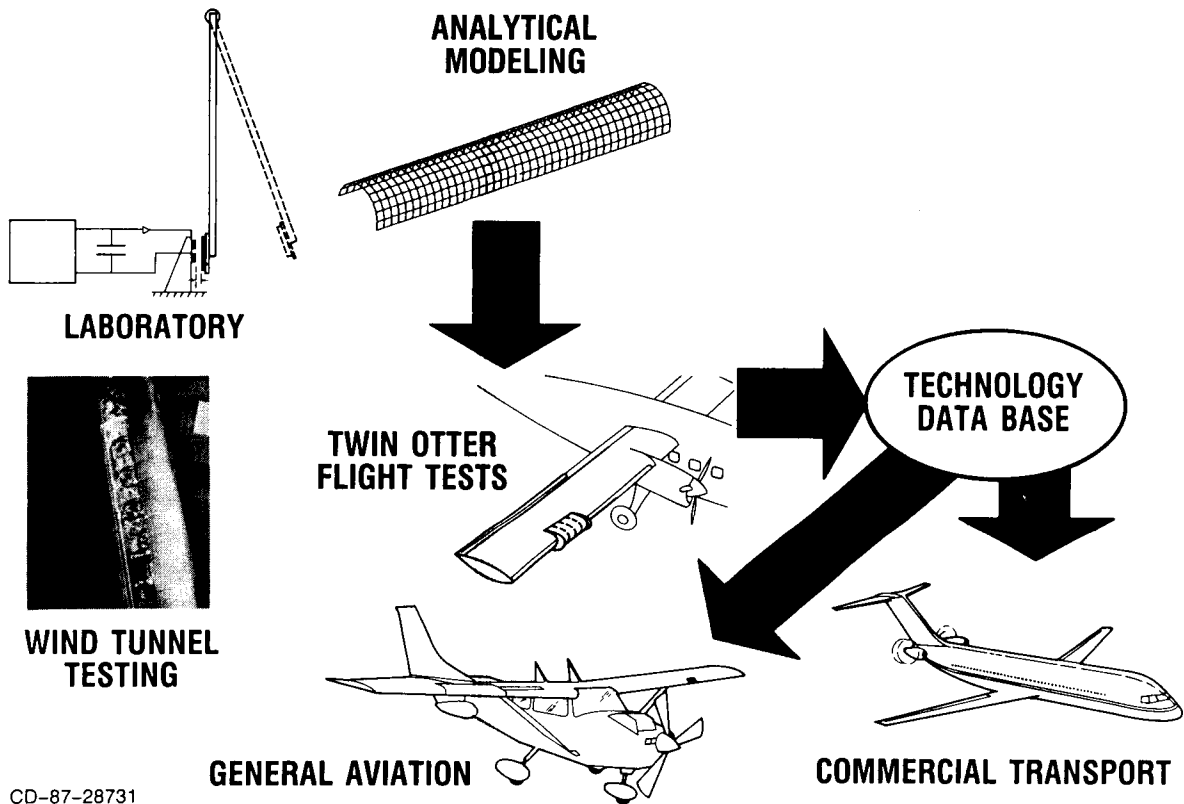

CD-87-28731



# NASA/ARMY/INDUSTRY ROTOR PNEUMATIC BOOT PROGRAM

A multi-year NASA/Army/industry program has demonstrated that a conventional pneumatic boot design can be used to protect the main rotor of the UH1H helicopter. The main steps of the program are shown.

ORIGINAL PAGE IS  
OE POOR QUALITY

## NASA/ARMY/INDUSTRY ROTOR PNEUMATIC BOOT PROGRAM



IRT TEST



OTTAWA SPRAY RIG

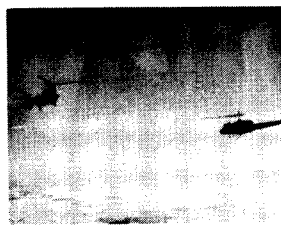
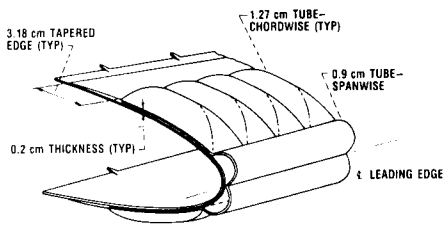

ARMY HISS TANKER

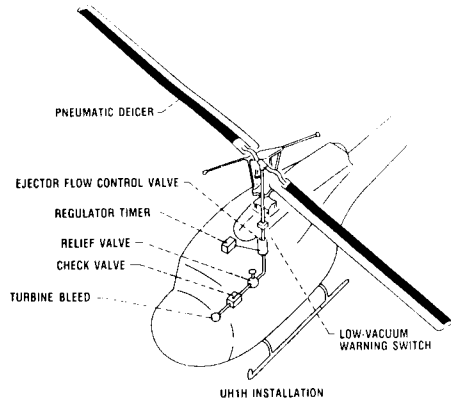

UH1H INSTALLATION



**DEMONSTRATED  
ROTOR DEICING  
CAPABILITY**

CD-87-28732

## **ANALYTICAL AND EXPERIMENTAL ICING SIMULATION**

- **DEVELOP/VALIDATE CODES TO PREDICT AIRCRAFT PERFORMANCE, STABILITY AND CONTROL IN ICING**
- **IMPROVE/VALIDATE ICING SIMULATION FACILITIES**
- **CONDUCT NATURAL/ARTIFICIAL ICING FLIGHT TESTS**
- **IMPROVE ICING INSTRUMENTATION**

## AIRCRAFT ICING ANALYSIS METHODOLOGY

The large number of computer codes and some of the required interfaces to form a comprehensive icing analysis methodology are shown.

## AIRCRAFT ICING ANALYSIS METHODOLOGY

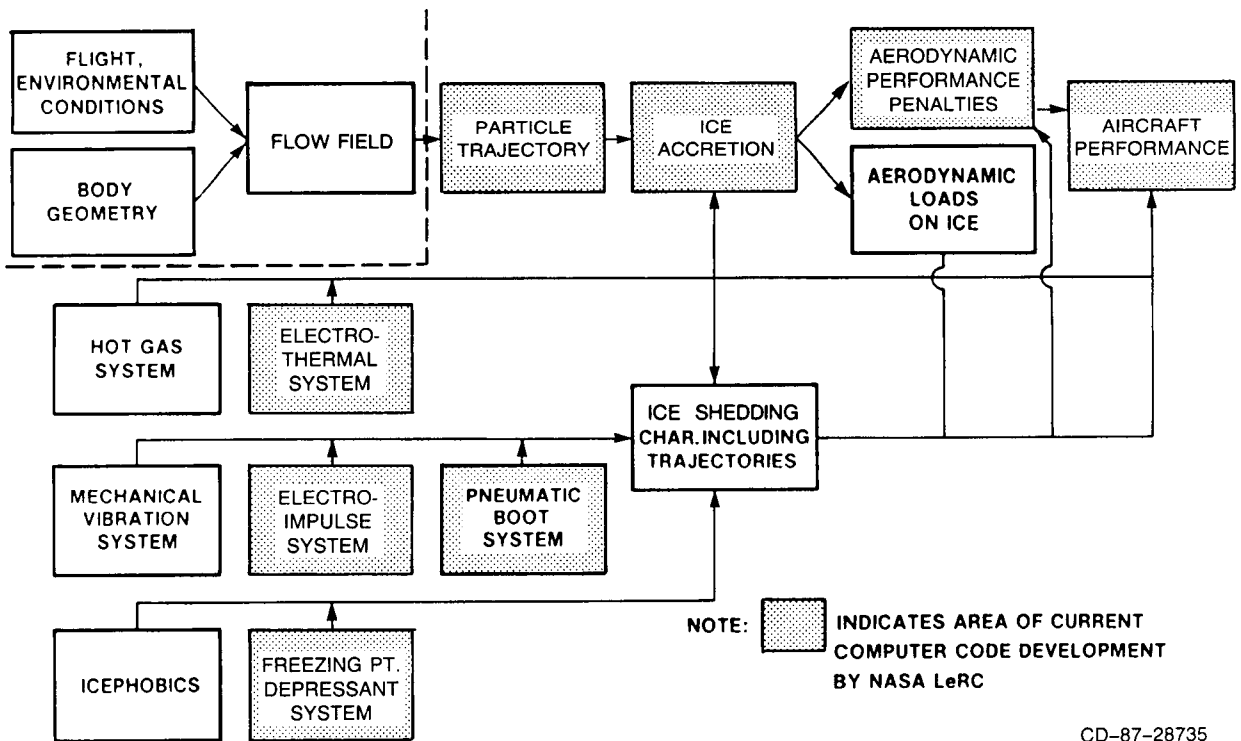

CD-87-28735

## COMPUTER CODES BEING DEVELOPED/VALIDATED

The individual computer codes currently being developed and validated are shown. This set of codes forms a core analysis capability which can be used to build the more comprehensive icing analysis capability which is desired.

## COMPUTER CODES BEING DEVELOPED/VALIDATED

- **TRAJECTORY ANALYSES**
  - TWO DIMENSIONAL
  - THREE DIMENSIONAL
  
- **AIRFOIL ICE ACCRETION**
  
- **AERODYNAMIC PERFORMANCE-IN-ICING**
  - AIRFOIL
  - PROPELLER, ROTOR (APPROXIMATE)
  - COMPLETE AIRCRAFT (APPROXIMATE)
  
- **ICE PROTECTION SYSTEMS**
  - ELECTROTHERMAL
  - ELECTROIMPULSE
  - FLUID FREEZING POINT DEPRESSANT
  - PNEUMATIC BOOT

CD-87-28734

NASA/FAA WATER DROPLET IMPINGEMENT RESEARCH PROGRAM

The major steps of the NASA/FAA program to acquire a validation data base for water droplet trajectory codes are shown.

ORIGINAL PAGE IS  
OF POOR QUALITY

**NASA/FAA WATER DROPLET IMPINGEMENT RESEARCH PROGRAM**  
OBJECTIVE - ACQUIRE A DATA BASE TO VALIDATE TRAJECTORY CODES

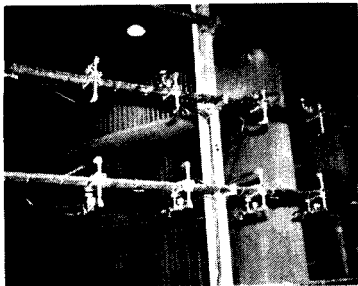

IRT NOZZLE SYSTEM

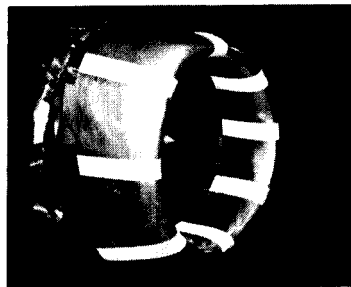

INLET MODEL WITH  
BLOTTER STRIPS

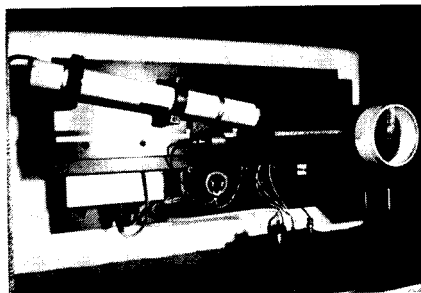

DATA  
REDUCTION  
SYSTEM

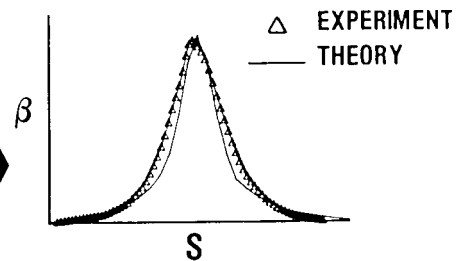

LOCAL COLLECTION  
EFFICIENCY DISTRIBUTION

CD-87-28736

## TWIN OTTER TRAJECTORY ANALYSIS

A computer graphics representation of the NASA icing research aircraft, a deHavilland DHC6 Twin Otter, is shown. This computer model is being used to calculate three-dimensional trajectories of water droplets about the aircraft to help in interpreting icing cloud instrument data.

## TWIN OTTER TRAJECTORY ANALYSIS

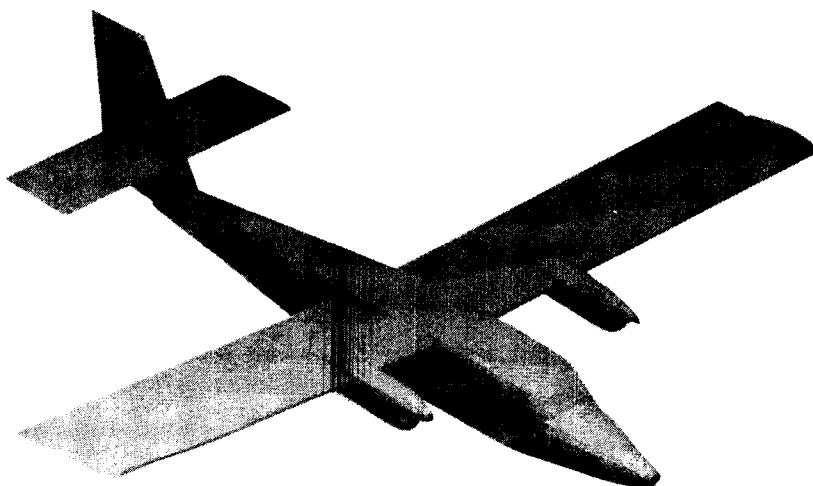

CD-87-28737

## TRAJECTORY ANALYSIS FOR LASER SPECTROMETER

Selected results for trajectory analysis studies of the laser spectrometer droplet sizing instrument are shown. The results show that significant error can occur when the instrument is mounted beneath the main wing of the aircraft. This error is attributed to the three-dimensional flowfield effects on the trajectories of the water droplets. The curves indicate that, for the droplet sizes of interest (~10 to 100  $\mu\text{m}$ ), the instrument will sense that fewer droplets/ $\text{m}^3$  exist than actually do exist in the "freestream" icing cloud.

## TRAJECTORY ANALYSIS FOR LASER SPECTROMETER

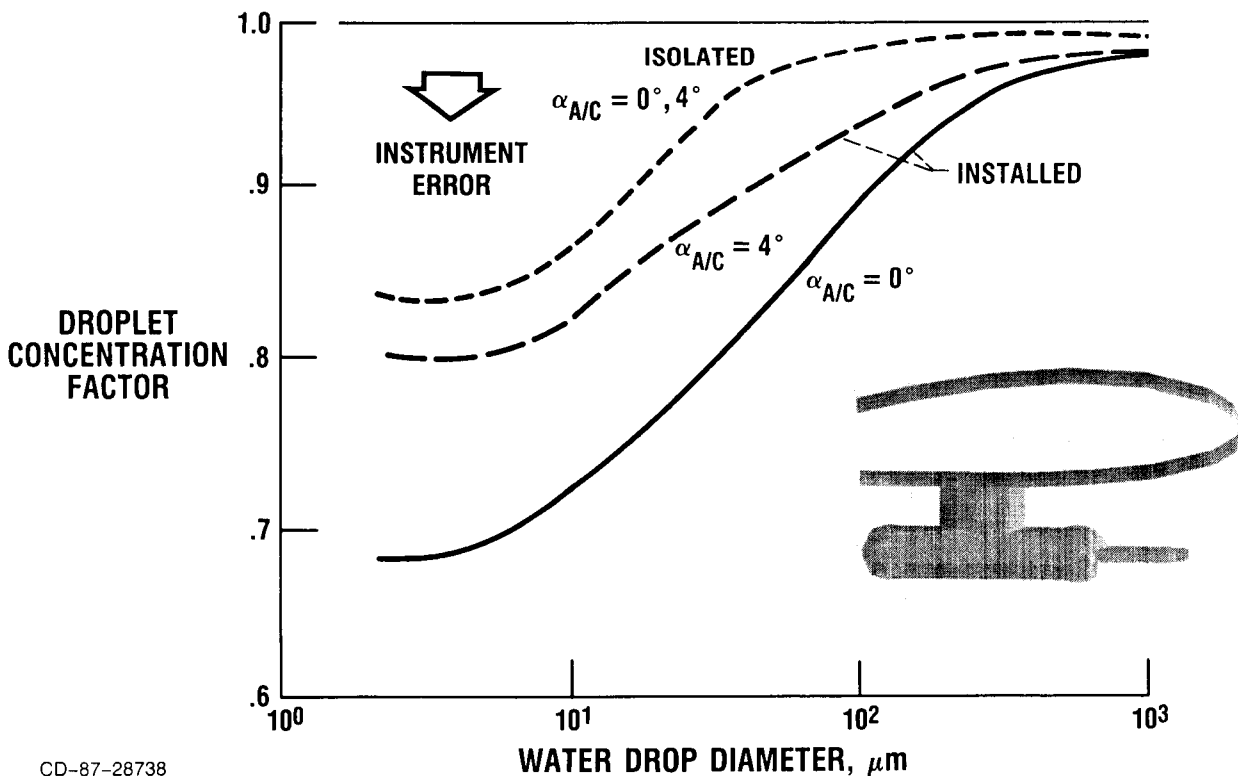

CD-87-28738

ORIGINAL PAGE IS  
OF POOR QUALITY

## NASA AIRFOIL ICE ACCRETION CODE (LEWICE)

An indication of the capability of the NASA ice accretion code (LEWICE) to predict the growth of ice on an airfoil is shown.

## NASA AIRFOIL ICE ACCRETION CODE (LEWICE)

COMPARISON OF GLAZE ICE SHAPES

NACA 0012 AIRFOIL, 21 in. CHORD

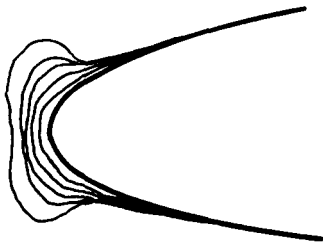

THEORETICAL

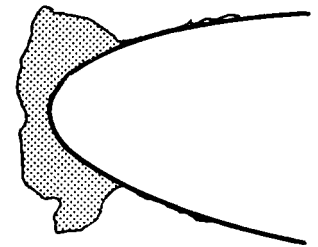
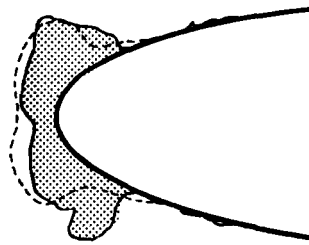

EXPERIMENTAL

VELOCITY, m/sec.....	89.40
TEMPERATURE, °C.....	-10.65
PRESSURE, kPa.....	94.20
HUMIDITY, percent.....	100
LWC, g/m <sup>3</sup> .....	1.20
DROP DIAMETER, μm.....	20
TIME, sec.....	240

CD-87-28739



## CLOSE UP FLASH PICTURE OF DROPLET IMPINGEMENT

A close up flash picture of droplet impingement on a surface is shown. These photographic studies are being done to better understand the physics of the ice accretion process. An improved understanding of the basic physics will result in improved ice accretion prediction capabilities.

ORIGINAL PAGE IS  
OF POOR QUALITY

## CLOSE UP FLASH PICTURE OF DROPLET IMPINGEMENT

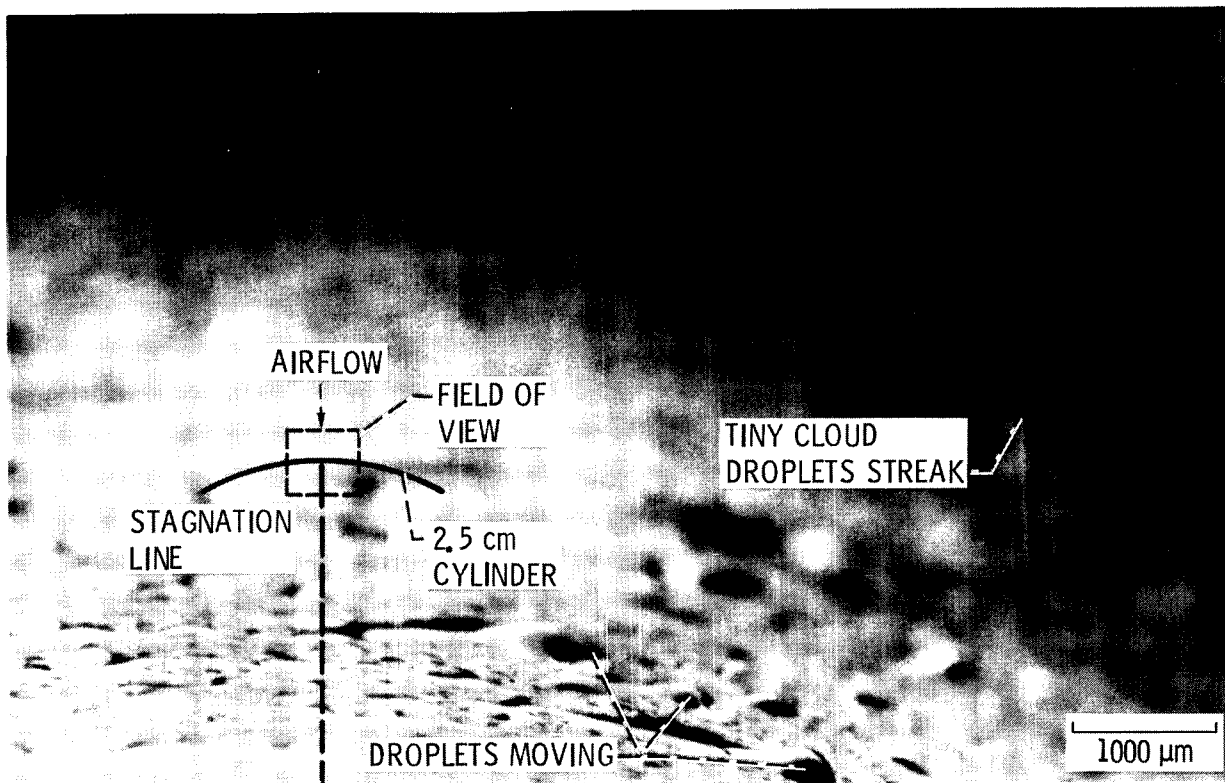

CD-87-28740

## ADHESIVE SHEAR STRESS VERSUS INTERFACE TEMPERATURE

Improved values for impact ice structural properties as well as adhesion strengths are required inputs to computer models of mechanical and thermal deicing systems. Fundamental experiments are being conducted to acquire such data and a representative sample of the data being acquired is shown.

## ADHESIVE SHEAR STRESS VERSUS INTERFACE TEMPERATURE

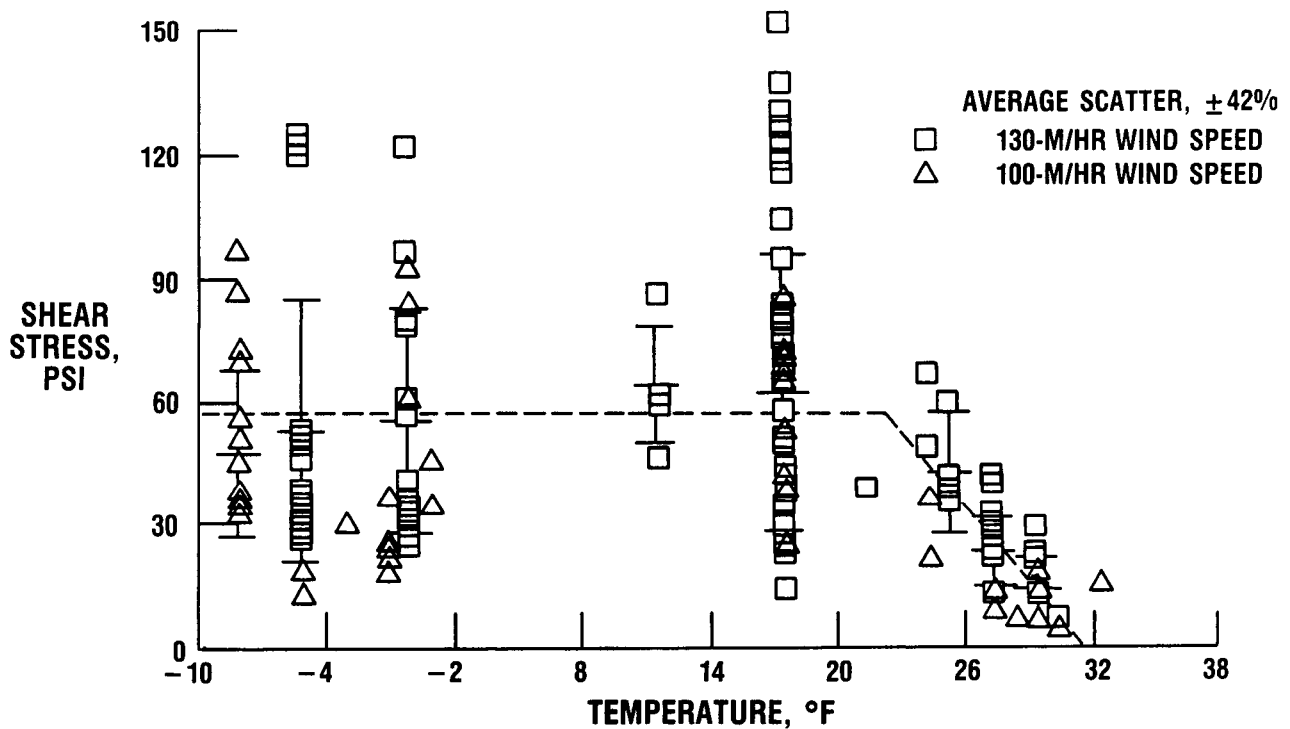

CD-87-28741

CODE VALIDATION STUDIES - ICED AIRFOIL ANALYSIS

Detailed data are required to evaluate the various codes being developed to predict airfoil aerodynamic performance degradation due to leading edge ice accretions. A summary of the data being acquired for a NACA 0012 model with an idealized leading edge ice accretion is shown.

ORIGINAL PAGE IS  
OF POOR QUALITY

CODE VALIDATION STUDIES—ICED AIRFOIL ANALYSIS

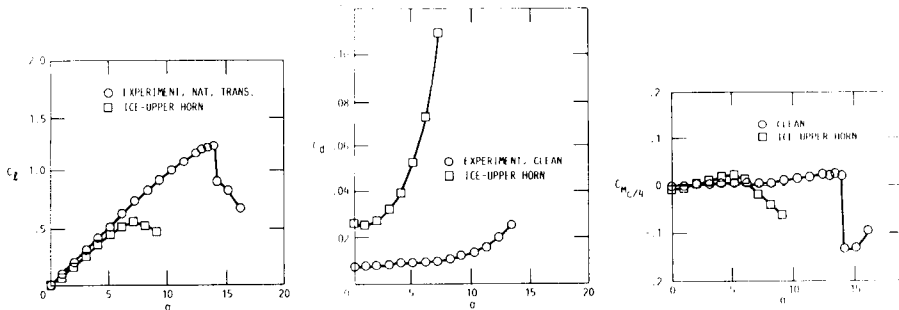

FORCE AND MOMENT DATA

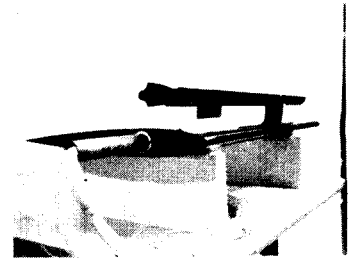

NACA 0012  
MODEL

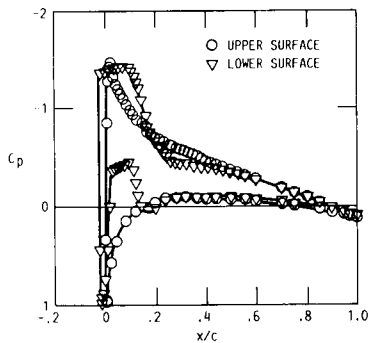

DETAILED SURFACE PRESSURES

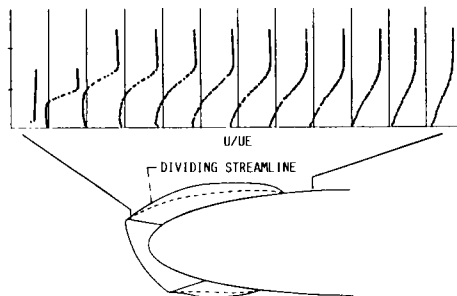

BOUNDARY LAYER  
PROFILES

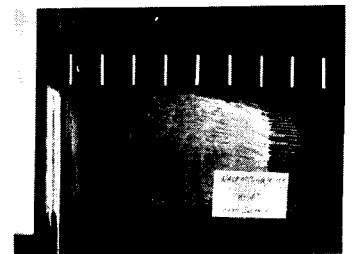

FLOW VISUALIZATION

CD-87-28742

## ICED AIRFOIL ANALYSIS

The "iced" airfoil predictions of the Navier-Stokes and interactive boundary layer codes are compared to the code validation data shown in the previous figure. The agreement is judged to be generally good for both codes.

## ICED AIRFOIL ANALYSIS

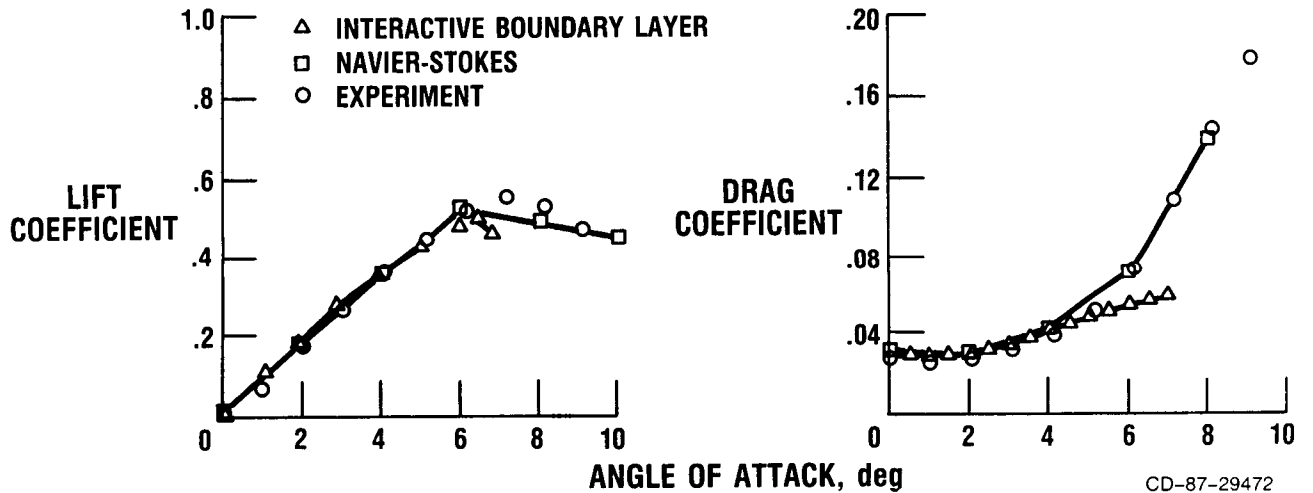
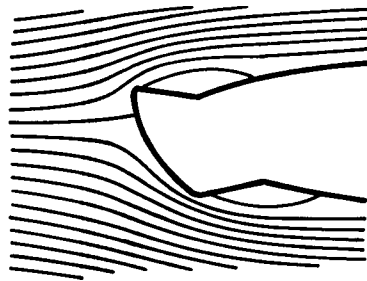

## COMPARISON OF LASER SPECTROMETER DROP SIZE INDICATIONS TO OLD IRT CALIBRATION

Droplet size measurements made in the Icing Research Tunnel (IRT) using various laser spectrometer probes are compared to the group of cloud droplet sizes using the facility calibration developed by NACA. The wide spread of the data away from the line of perfect agreement suggests the need for improvements in the accuracy of droplet sizing instrumentation. The data taken in this test program suggested current instrumentation accuracies of no better than  $\pm 4 \mu\text{m}$  (on a volume median diameter (VMD) basis).

## COMPARISON OF LASER SPECTROMETER DROP SIZE INDICATIONS TO OLD IRT CALIBRATION

RANGE OF CONDITIONS:  $10 < \text{DVM} < 30 \mu\text{m}$ ;  $0.3 < \text{LWG} < 3 \text{ g/M}^3$ ;  $80 < V < 460 \text{ KM/HR}$

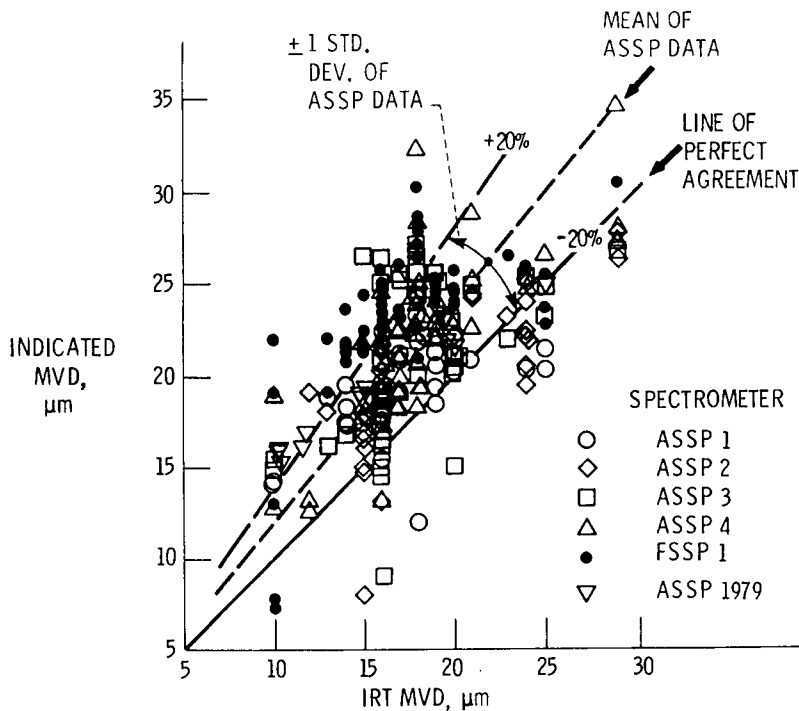

## EFFECTS OF DROP SIZE MEASUREMENT ERRORS

The effect of a  $\pm 4 \mu\text{m}$  variation of volume median diameter (VMD) on ice accretion shape and resulting airfoil drag increase are shown. The figure suggests the effects can be significant and that the accuracy of droplet sizing instrumentation must be improved.

## EFFECTS OF DROP SIZE MEASUREMENT ERRORS

	DROP SIZE, $\mu\text{m}$	DRAG COEFFICIENT $C_d$
————	25	0.074
- - - -	21	.039
- . - .	17	.015
	DRY	.0085

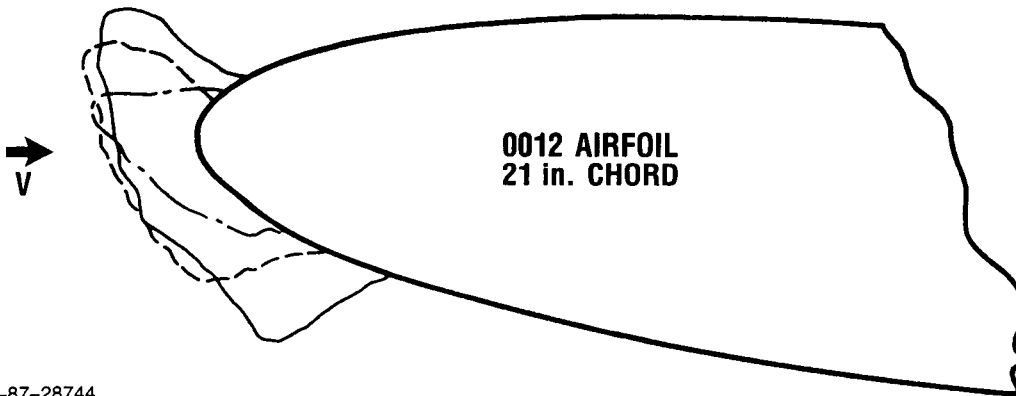

CD-87-28744

## PARTICLE SIZING INSTRUMENTATION RESEARCH

The current activities to improve the accuracy of existing droplet sizing instrumentation are shown.

ORIGINAL PAGE IS  
OF POOR QUALITY

## PARTICLE SIZING INSTRUMENTATION RESEARCH

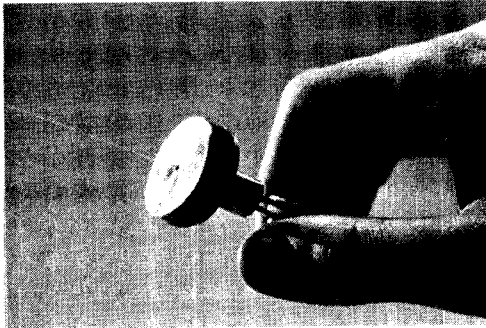

**CALIBRATION DEVICES**

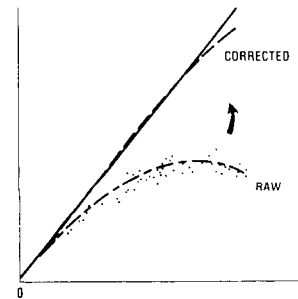
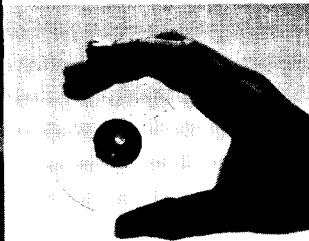

**DATA CORRECTION  
ALGORITHMS**

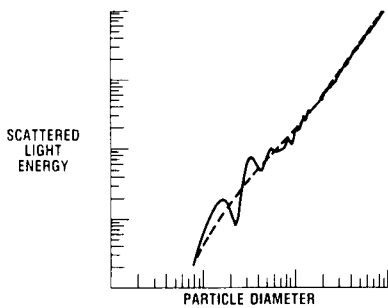

**THEORETICAL MODELING**

CD-87-28745

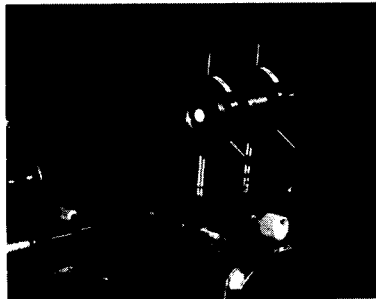

**FUNDAMENTAL  
RESEARCH**

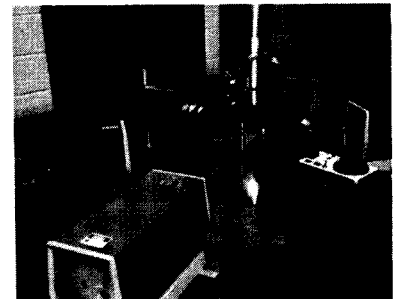

**INSTRUMENT  
COMPARISONS**

# ICING RESEARCH TUNNEL

The NASA Icing Research Tunnel (IRT), the largest refrigerated icing wind tunnel in the world, recently underwent a \$3.6M upgrade to modernize the facility which began operation in 1944. The key features of the "new" IRT are shown.

ORIGINAL PAGE IS  
OF POOR QUALITY

## ICING RESEARCH TUNNEL

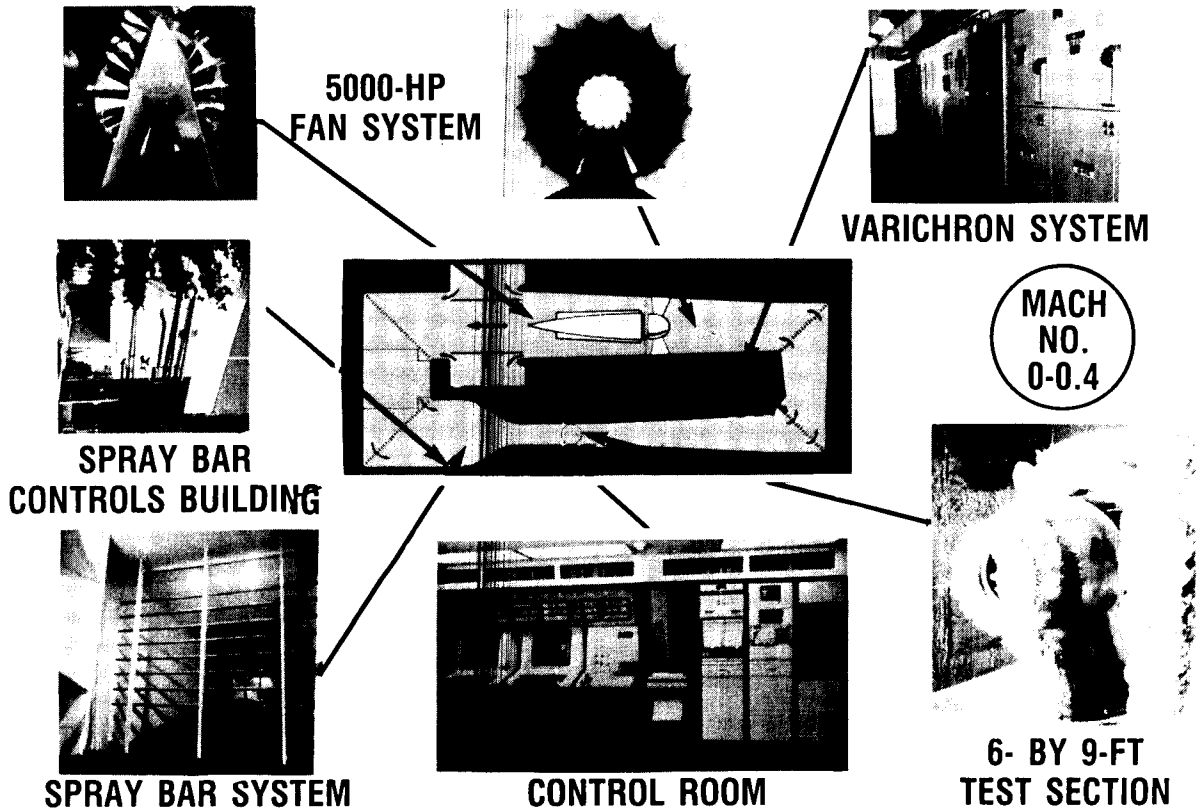

CD-87-28746



# TWIN OTTER WING ICING/AEROPERFORMANCE

The major objective of the icing flight research portion of the program is to acquire a data base which can be used to validate experimental and analytical simulations of icing. The key components of the data base being acquired are shown.

ORIGINAL PAGE IS  
OF POOR QUALITY

## TWIN OTTER WING ICING/AERO PERFORMANCE

### ICING CLOUD INSTRUMENTS

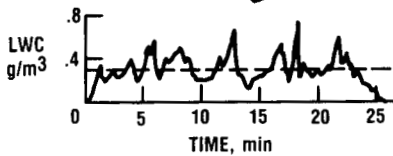

### STEREO PHOTOGRAPHY SYSTEM

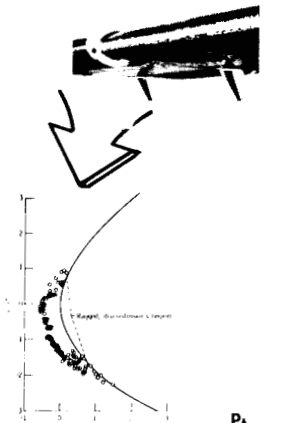

### WAKE SURVEY PROBE

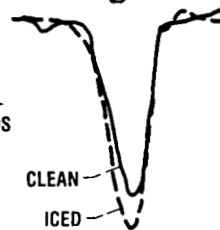
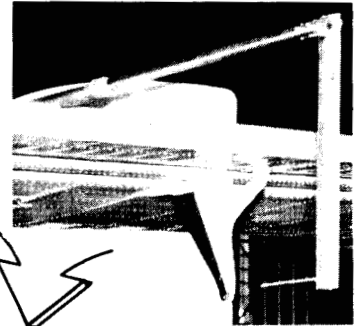

ICING  
SIMULATION  
VALIDATION  
DATA BASE

CD-87-28747

## AIRCRAFT PERFORMANCE IN NATURAL ICING

The aircraft is also being used to acquire aircraft performance/stability control changes due to icing. Representative samples of data acquired are shown.

## AIRCRAFT PERFORMANCE IN NATURAL ICING

EXPERIMENTAL DATA BASE IS BEING ACQUIRED, RELATING AIRCRAFT PERFORMANCE DEGRADATION TO A MATRIX OF MEASURED NATURAL ICING CONDITIONS

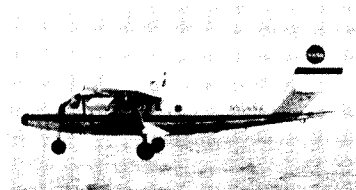

**NASA DHC-6 TWIN OTTER  
ICING RESEARCH AIRCRAFT**

### GLAZE ICING ENCOUNTER

MVD -  $13\mu\text{m}$       ICING TIME - 26 min  
LWC -  $0.31\text{g/m}^3$     STATIC TEMP. -  $-4\text{ }^\circ\text{C}$

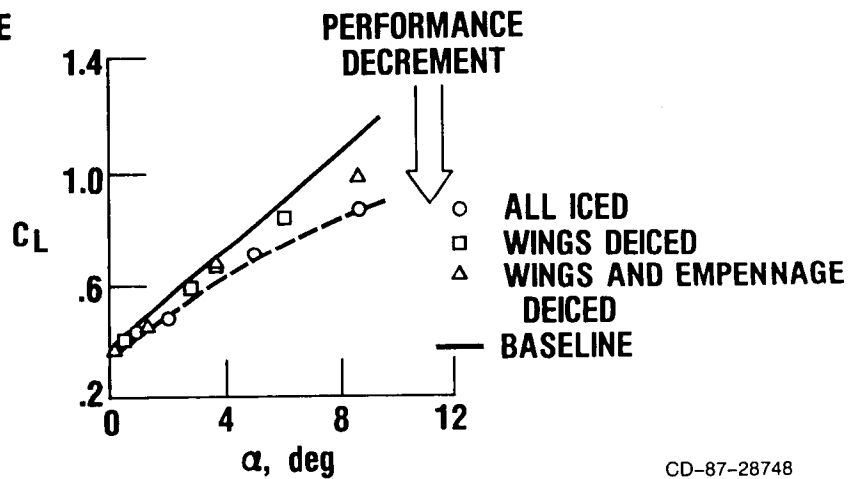
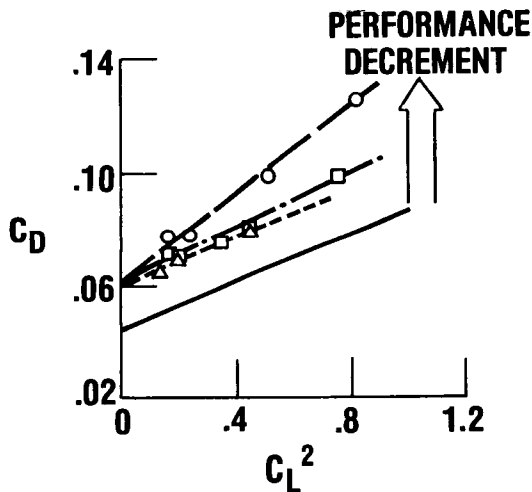

CD-87-28748

REDUCTION OF AIRCRAFT STATIC LONGITUDINAL STABILITY DUE TO ICING

REDUCTION OF AIRCRAFT STATIC LONGITUDINAL STABILITY DUE TO ICING

OBJECTIVE: EMPLOY STATIC LONGITUDINAL FLIGHT TEST METHODS TO A DHC-6 AIRCRAFT WITH AN ARTIFICIAL ICE SHAPE ATTACHED TO THE HORIZONTAL TAIL PLANE TO MEASURE THE CHANGE IN STATIC MARGIN

RESULTS: A REDUCTION IN STATIC MARGIN WAS MEASURED THROUGHOUT THE NORMAL FLAPS-UP CRUISE ENVELOPE

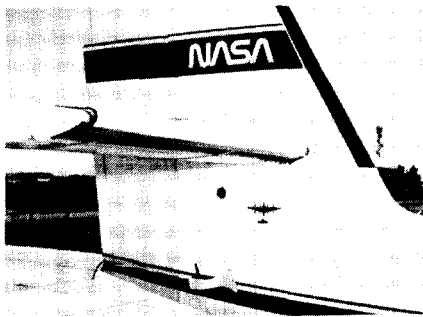

ARTIFICIAL MODERATE GLAZE ICE SHAPE ATTACHED TO HORIZONTAL TAIL

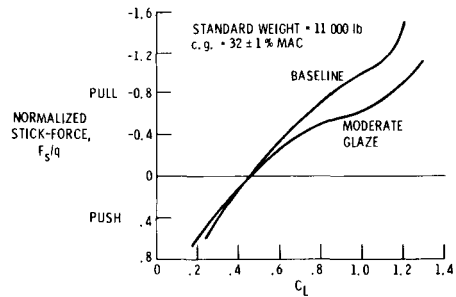

VARIATION IN NORMALIZED CONTROL FORCE FOR THE "ICED" VERSUS BASELINE TAIL

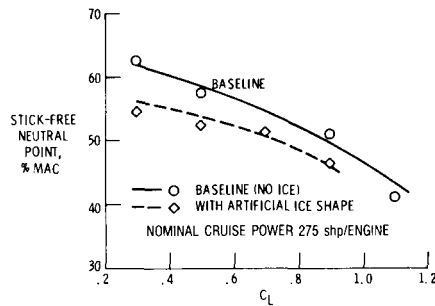

REDUCTION IN STICK-FREE STATIC MARGIN DUE TO TAIL ICE

CD-87-28749

# MODEL ROTOR ICING PROGRAM

The evaluation of the technique of testing model helicopter rotors in the IRT is the current focus of the helicopter related icing research. This effort is a joint NASA/industry/university program, and the key elements of the initial phases of the multi-year program are shown.

ORIGINAL PAGE IS  
OF POOR QUALITY

## MODEL ROTOR ICING PROGRAM

BOEING-VERTOL

McDONNELL-DOUGLAS

NASA

TEXAS A&M UNIV.

BELL

SIKORSKY

- TEST PLANNING
- MODEL PREPARATION
- DATA ACQUISITION SYSTEM
- DRY WIND TUNNEL TESTS



TEST TECHNIQUES RIG  
(OH58 TAIL ROTOR)



FULLY INSTRUMENTED MODEL  
(SIKORSKY PFM)

THOROUGH  
EVALUATION  
OF MODEL  
ROTOR ICING  
TEST TECHNIQUE

CD-87-28750

## HELICOPTER ICING FLIGHT TEST PROGRAM

The NASA/Army/industry/university helicopter icing flight test program was a multi-phase effort to acquire unprotected helicopter rotor ice accretion and aerodynamic performance data for both hover and forward flight conditions. The test techniques developed will be used in a proposed future program to acquire flight data for comparison with scale model rotor data which will be acquired.

## HELICOPTER ICING FLIGHT TEST PROGRAM

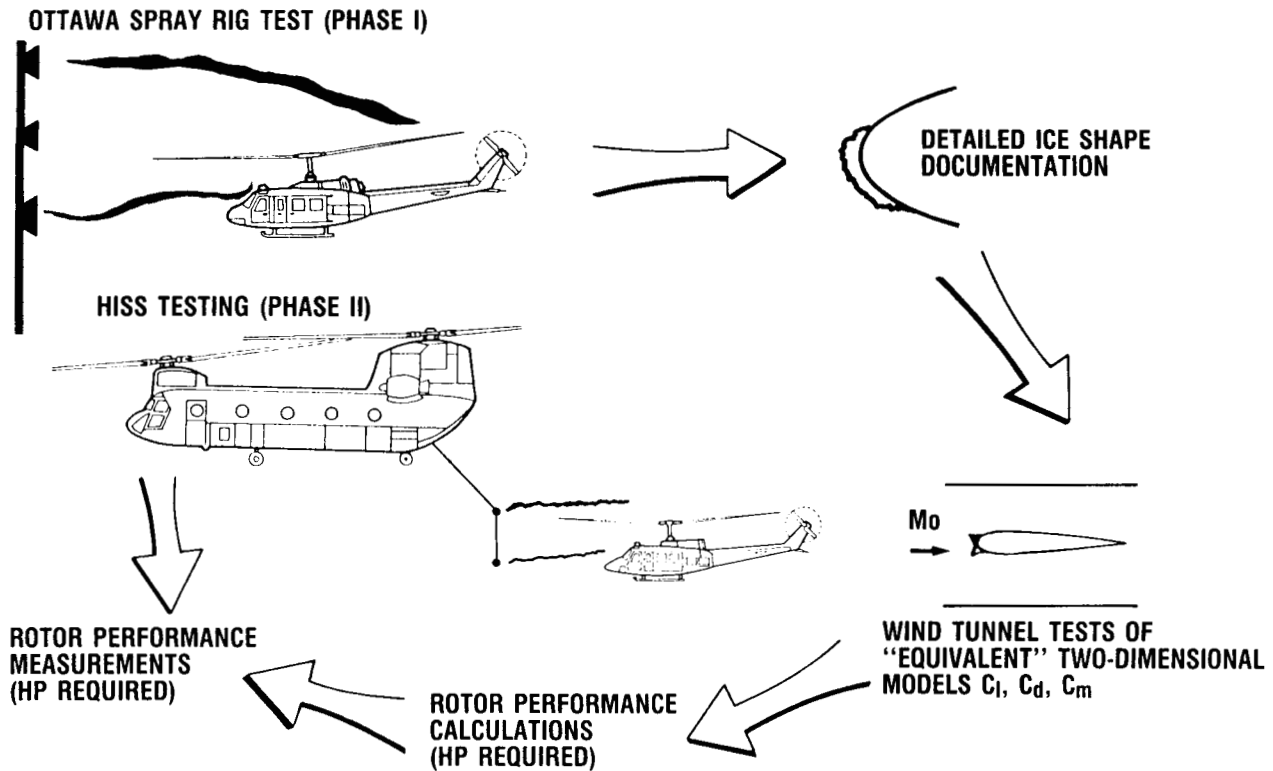

CD-87-28751

## AIRCRAFT ICING TECHNOLOGY PROGRAM

The areas of future emphasis in the program are shown in this figure. The basic or generic icing research activities will be continued and this technology will be applied to the fixed wing aircraft to develop icing effects simulations. These simulations will be computer based and validated through appropriate wind tunnel and flight test programs. In the longer term, the emphasis will switch toward rotorcraft applications where again icing effects simulations will be developed and validated. In addition, rotor icing test techniques will be developed and validated and alternate concepts for rotor ice protection will be sought.

## AIRCRAFT ICING TECHNOLOGY PROGRAM

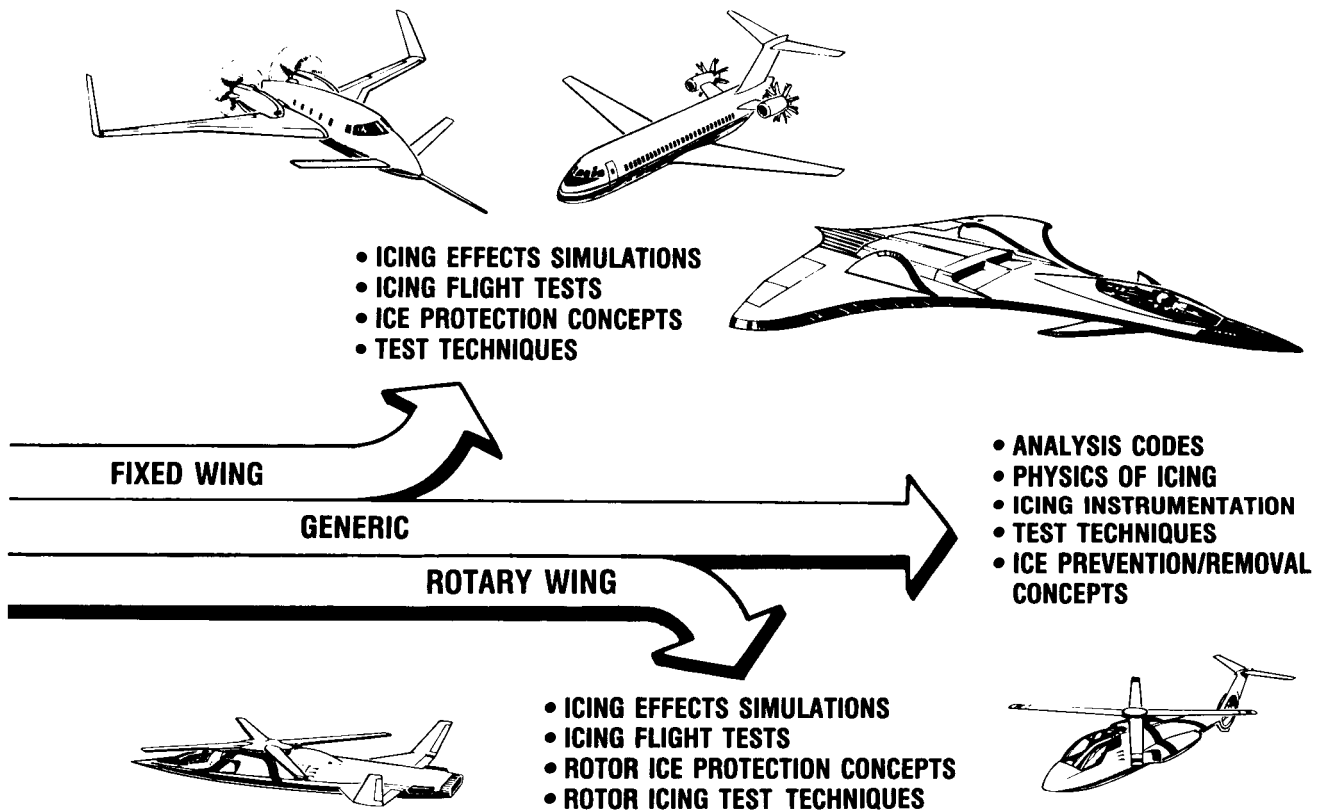

CD-87-28729

N88-15804

54-07  
110879  
109.

**AIRCRAFT ENGINE HOT SECTION TECHNOLOGY -  
AN OVERVIEW OF THE HOST PROJECT**

Daniel E. Sokolowski  
and  
Marvin H. Hirschberg

NASA sponsored the Turbine Engine Hot Section Technology (HOST) Project to address the need for improved durability in advanced aircraft engine combustors and turbines. Analytical and experimental activities aimed at more accurate prediction of the aerothermal environment, the thermomechanical loads, the material behavior and structural responses to loads, and life predictions for cyclic high-temperature operation have been underway for the last 7 years. The project has involved representatives from six engineering disciplines who are spread across three work sectors - industry, academia, and NASA. The HOST Project not only initiated and sponsored 70 major activities, but also was the keystone in joining the multiple disciplines and work sectors to focus on critical research needs. A broad overview of the project is given along with initial indications of the project's impact.

**PRECEDING PAGE BLANK NOT FILMED**

## TRENDS IN TURBINE ENGINE OPERATING REQUIREMENTS

Since introduction of the gas-turbine engine to aircraft propulsion, the quest for greater performance has resulted in a continuing upward trend in overall pressure ratio for the engine core. Associated with this trend are increasing temperatures of gases flowing from the compressor and combustor and through the turbine. For commercial aircraft engines in the foreseeable future, compressor discharge temperature will exceed 922 K (1200 °F), while turbine inlet temperature will be approximately 1755 K (2700 °F). Military aircraft engines will significantly exceed these values.

## TRENDS IN TURBINE ENGINE OPERATING REQUIREMENTS

### ENGINE

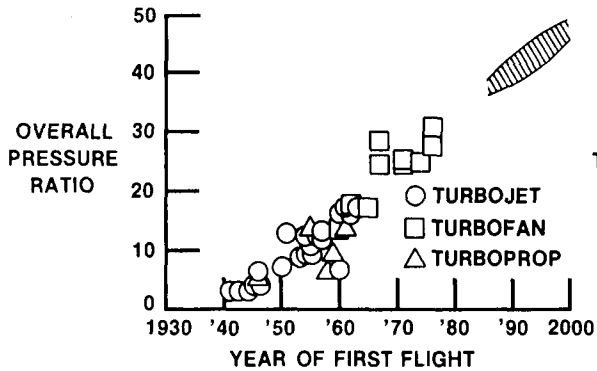

### HOT SECTION

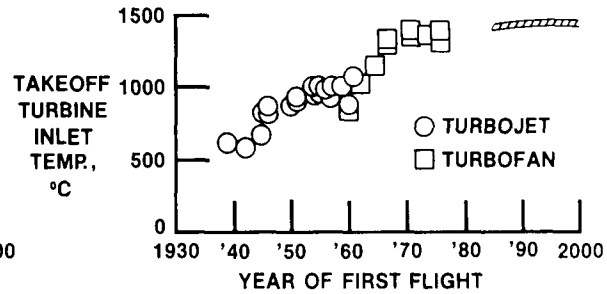

CD-87-29607



## IMPACT OF MORE SEVERE OPERATING CONDITIONS ON COMBUSTOR LINERS

Since 1973 increasing fuel prices have created the demand for energy conservation and more fuel efficient aircraft engines. In response to this demand engine manufacturers continually increased the performance of current generation gas-turbine engines. Soon afterward, the airline industry began to experience a notable decrease in the durability or useful life of critical parts in the engine hot section - the combustor and turbine. This was due primarily to cracking in the combustor liners, turbine vanes, and turbine blades. Spalling of thermal barrier coatings that protect combustor liners also occurred.

## IMPACT OF MORE SEVERE OPERATING CONDITIONS ON COMBUSTOR LINERS

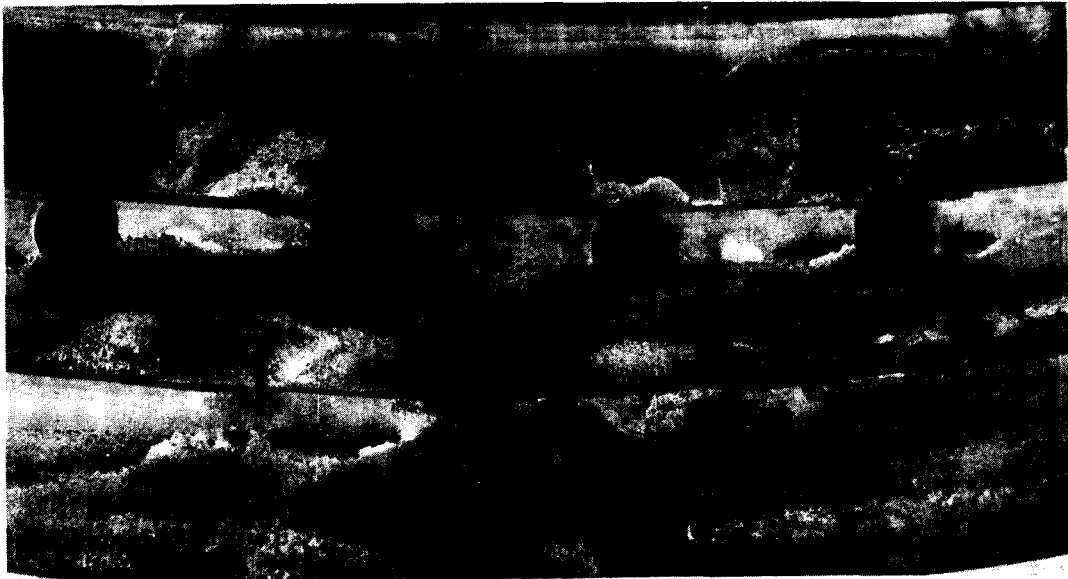

- AXIAL AND CIRCUMFERENTIAL CRACKS
- EXTENSIVE SPALLING OF THERMAL BARRIER COATING

CD-87-29608

ORIGINAL PAGE IS  
OF POOR QUALITY

## EFFECT OF MORE SEVERE OPERATING CONDITIONS ON ENGINE MAINTENANCE

For the airlines reduced durability for in-service engines was measured by a dramatic increase in maintenance costs, primarily for high bypass ratio engines. Higher maintenance costs were especially evident in the hot section. Hot section maintenance costs account for almost 60 percent of the engine total.

## EFFECT OF MORE SEVERE OPERATING CONDITIONS ON ENGINE MAINTENANCE

“HOT SECTION PARTS ACCOUNT FOR 60 PERCENT OF ENGINE MAINTENANCE COSTS. IN 1978, APPROXIMATELY \$400 MILLION WAS SPENT...”

A.J. DENNIS, PRATT & WHITNEY (AIAA 79-1154)

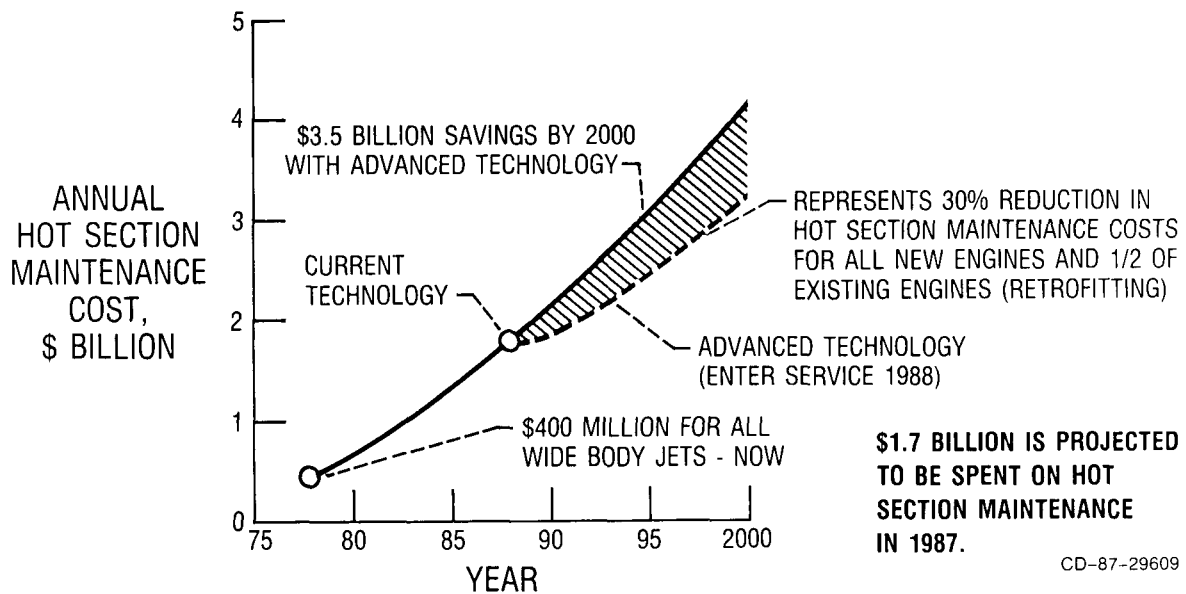

## IMPACT OF MORE SEVERE OPERATING CONDITIONS ON FLIGHT SAFETY

Besides having an effect on maintenance costs, failure of hot section parts can affect flight safety. An example is a Boeing 737 accident in Manchester, England, in August 1985, with the loss of 55 lives. The accident was a direct result of failure due to cracking in a combustor liner and subsequent puncture of a wing fuel tank.

ORIGINAL PAGES  
OF POOR QUALITY

## IMPACT OF MORE SEVERE OPERATING CONDITIONS ON FLIGHT SAFETY

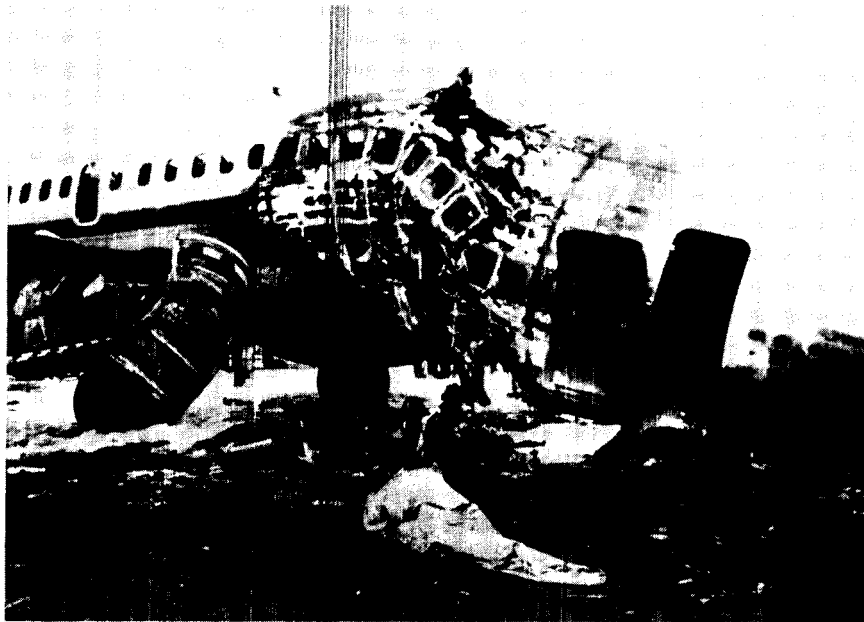

CD-87-29610

## APPROACHES TO IMPROVING HOT SECTION DURABILITY

Durability can be improved in hot section components by using a single approach or a combination of the four approaches described below.

### (1) High-Temperature Materials

High-temperature metallic materials currently include nickel- and cobalt-based superalloys. Certain elements of these alloys, such as cobalt, are in short supply and are expensive. Recently, researchers completed a study of ways to reduce their usage. Advanced high-temperature superalloy components also include directionally solidified, single-crystal, and oxide-dispersion-strengthened materials. For such materials, the development time is lengthy, fabrication is sometimes difficult, and, again, costs are high. Thus, successful use of these materials requires a balance among design requirements, fabrication possibilities, and total costs.

### (2) More Effective Cooling Techniques

Current cooling techniques tend to be sophisticated; fabrication is moderately difficult. In higher performance engines cooling capability may be improved by increasing the amount of coolant. But the penalty for doing this is a reduction of thermodynamic cycle performance of the engine system. In addition, the coolant temperature of such advanced engines is higher than that for current in-service engines. Consequently, more effective cooling techniques are being investigated. Generally, they are more complex in design, demand new fabrication methods, and may require a multitude of small cooling holes, each of which introduces potential life-limiting high stress concentrations. Acceptable use of the advanced cooling techniques will require accurate models for design analysis.

### (3) Advanced Structural Design Concepts

The introduction of advanced structural design concepts usually begins with a preliminary concept that then must be proven, must be developed, and -- most critically -- must be far superior to entrenched standard designs. Acceptance certainly is time consuming, and benefits must be significant. For improved durability in high performance combustors, an excellent example of an advanced structural design concept is the segmented liner. The life-limiting problems associated with high hoop stresses were eliminated by dividing the standard full-hoop liners into segments. At the same time, designers realized increased flexibility in the choice of advanced cooling techniques and materials, including ceramic composites.

### (4) More Accurate Design Analysis Tools

Finally, the design analysis of hot section component parts, such as the combustor liners or turbine vanes and blades, involves the use of analytical or empirical models. Such models often involve computer codes for analyzing the aerothermal environment, the thermomechanical loads, heat transfer, and material and structural responses to such loading. When the parts are exposed to high-temperature cyclic operation as in a turbine engine, the repetitive straining of the materials invariably leads to crack initiation and propagation until failure or break-away occurs. The useful life of a part is usually defined as the number of mission cycles that can be accumulated before initiation of significant cracks. Thus, designers need to predict useful life accurately so they can design a part to meet requirements.

## FRAMEWORK FOR THE HOST PROJECT

Efforts to predict the life of a part generally follow the flow of analytical models shown in the figure. Thus, designing a part such as a turbine blade to meet a specified life goal may require several iterations through the life prediction system, varying the blade geometry, material, or cooling effectiveness in each pass, until a satisfactory life goal is predicted.

## FRAMEWORK FOR THE HOST PROJECT

INTEGRATION OF ANALYSES LEADS TO LIFE PREDICTION

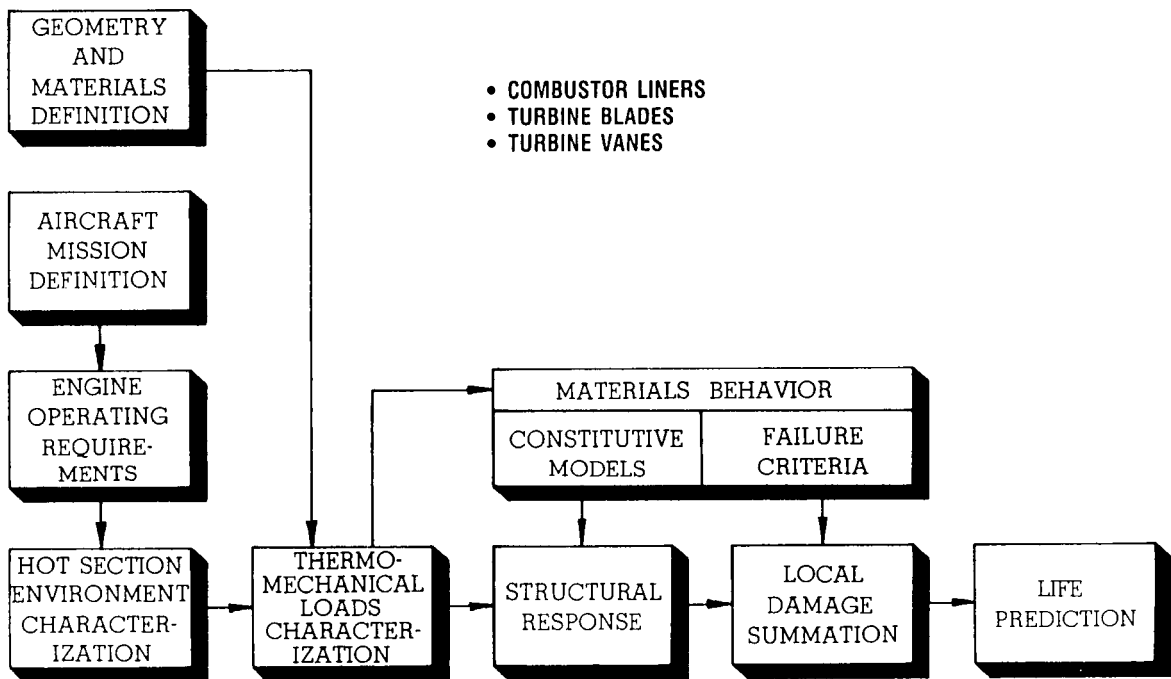

CD-87-29612

## THE HOST PROJECT

To meet the needs for improved analytical design and life prediction tools, especially those used for high-temperature cyclic operation in advanced combustors and turbines, NASA has sponsored the Turbine Engine Hot Section Technology (HOST) Project. The project was conducted from fiscal year 1981 through 1987.

The HOST Project has developed improved analytical models for the aerothermal environment, the thermomechanical loads, material behavior, structural response, and life prediction, along with more sophisticated computer codes, which can be used in design analyses of critical parts in advanced turbine engine combustors and turbines. Use of these more accurate analytical tools during the design process will ensure improved durability of future hot section engines components.

The complex durability problem in high-temperature, cyclically operated turbine engine components requires the involvement of numerous research disciplines. This involvement must include, not only focused research, but also interdisciplinary and integrated efforts. The disciplines included in HOST were instrumentation, combustion, turbine heat transfer, structural analysis, fatigue and fracture, and surface protection.

Most disciplines in the HOST Project followed a common approach. First, phenomena related to durability were investigated, often using benchmark experiments. With known boundary conditions and proper instrumentation, these experiments resulted in a better characterization and understanding of such phenomena as the aerothermal environment, the material and structural behavior during thermomechanical loading, and crack initiation and propagation. Second, state-of-the-art analytical models were identified, evaluated, and then improved upon through use of more inclusive physical considerations and/or more advanced computer code development. When no state-of-the-art models existed, researchers developed new models. Finally, predictions using the improved analytical tools were validated by comparison with experimental results, especially the benchmark data.

## THE HOST PROJECT

### OBJECTIVE

- PROVIDE MORE ACCURATE DESIGN ANALYSIS TOOLS WHICH WILL BETTER ENSURE, DURING THE DESIGN PROCESS, IMPROVED DURABILITY OF HOT SECTION COMPONENTS.

### APPROACH

- FOCUS MULTIDISCIPLINARY RESEARCH TOWARD
  - BENCHMARK QUALITY EXPERIMENTS
  - ADVANCED ANALYTICAL MODELS
  - IMPROVED COMPUTER CODES

CD-87-29613

## HOST PROJECT ACTIVITIES

The HOST Project initiated and sponsored 70 major research activities across six technical disciplines. Research results from some of these activities are reported throughout this publication.

	Contract (C), grant (G), or NASA organization (N) number		Contract (C), grant (G), or NASA organization (N) number
<u>Instrumentation</u>			
Hot Section Viewing System . . . . .	C NAS3-23156	<u>Turbine Heat Transfer</u>	
Dynamic Gas Temperature Measurement System - A . . . . .	C NAS3-23154	Advanced Instrumentation Development . .	N 2640
Dynamic Gas Temperature Measurement System - B . . . . .	C NAS3-24228	Warm Turbine Flow Mapping with Laser Anemometry . . . . .	N 2620
Turbine Static Strain Gage - A . . . . .	C NAS3-23169	Real Engine-Type Turbine Aero- thermal Testing . . . . .	N 2640
Turbine Static Strain Gage - B . . . . .	C NAS3-23722	<u>Structural Analysis</u>	
Turbine Heat Flux Sensors . . . . .	C NAS3-23529	Thermal/Structural Load Transfer Code . .	C NAS3-23272
Laser Speckle Strain Measurement . . . . .	C NAS3-26615	3D Inelastic Analysis Methods - I . . . .	C NAS3-23697
High Temperature Strain Gage Materials . . . . .	G NAG3-501	3D Inelastic Analysis Methods - II . . . .	C NAS3-23698
Hot Section Sensors . . . . .	N 2510	Component Specific Modeling . . . . .	C NAS3-23687
Laser Anemometry for Hot Section Applications . . . . .	N 2520/2530	Liner Cyclic Life Determination . . . . .	N 5210
HOST Instrument Applications . . . . .	N 2510	Structural Components Response Program . . . . .	N 5210
<u>Combustion</u>			
Assessment of Combustor Aerothermal Models - I . . . . .	C NAS3-23523	High Temperature Structures Research Laboratory . . . . .	N 5210
Assessment of Combustor Aerothermal Models - II . . . . .	C NAS3-23524	Constitutive Model Development . . . . .	N 5210
Assessment of Combustor Aerothermal Models - III . . . . .	C NAS3-23525	Constitutive Modeling for Isotropic Materials - I . . . . .	C NAS3-23925
Improved Numerical Methods - I . . . . .	C NAS3-24351	Constitutive Modeling for Isotropic Materials - II . . . . .	C NAS3-23927
Improved Numerical Methods - II . . . . .	C NAS3-24350	Theoretical Constitutive Models for Single Crystal Alloys . . . . .	G NAG3-511
Improved Numerical Methods - III . . . . .	G NAG3-596	Biaxial Constitutive Equation Develop- ment for Single Crystals and Directionally Solidified Alloys . . . . .	G NAG3-512
Flow Interaction Experiment . . . . .	C NAS3-24350	<u>Fatigue and Fracture</u>	
Fuel Swirl Characterization - I . . . . .	C NAS3-24350	Creep-Fatigue Life Prediction for Isotropic Materials . . . . .	C NAS3-23288
Fuel Swirl Characterization - II . . . . .	C NAS3-24352	Elevated Temperature Crack Propagation . . . . .	C NAS3-23940
Mass and Momenta Transfer . . . . .	C NAS3-22771	Life Prediction and Material Consti- tutive Behavior for Anisotropic Materials . . . . .	C NAS3-23939
Diffuser/Combustor Interaction . . . . .	C F33615-84-C-24 27	Analysis of Fatigue Crack Growth Mechanism . . . . .	G NAG3-348
Dilution Jet Mixing Studies . . . . .	C NAS3-22110	Vitalization of High Temperature Fatigue and Structures Laboratory . . . .	N 5220
Lateral Jet Injection into Typical Combustor Flowfields . . . . .	G NAG3-549	<u>Surface Protection</u>	
Flame Radiation Studies . . . . .	N 2780	Effects of Surface Chemistry on Hot Corrosion . . . . .	C NAS3-23926
<u>Turbine Heat Transfer</u>			
Mainstream Turbulence Influence on Flow in a Turning Duct - A . . . . .	C NAS3-23278	Thermal Barrier Coating Life Prediction - I . . . . .	C NAS3-23943
Mainstream Turbulence Influence on Flow in a Turning Duct - B . . . . .	G NAG3-617	Thermal Barrier Coating Life Prediction - II . . . . .	C NAS3-23944
2-D Heat Transfer without Film Cooling . . . . .	C NAS3-22761	Thermal Barrier Coating Life Prediction - III . . . . .	C NAS3-23945
2-D Heat Transfer with Leading-Edge Film Cooling . . . . .	C NAS3-23695	Airfoil Deposition Model . . . . .	G NAG3-201
2-D Heat Transfer with Downstream Film Cooling . . . . .	C NAS3-24619	Mechanical Behavior of Thermal Barrier Coatings . . . . .	G NCC3-27
Measurement of Blade and Vane Heat Transfer Coefficient in a Turbine Rotor . . . . .	C NAS3-23717	Coating Oxidation/Diffusion Prediction . . . . .	N 5120
Assessment of 3-D Boundary Layer Code . . . . .	C NAS3-23716	Deposition Model Verification . . . . .	N 5140
Coolant Side Heat Transfer with Rotation . . . . .	C NAS3-23691	Dual Cycle Attack . . . . .	N 5120
Analytic Flow and Heat Transfer . . . . .	C NAS3-24358	Rig/Engine Correlation . . . . .	N 5120
Effects of Turbulence on Heat Transfer . . . . .	G NAG3-522	Burner Rig Modernization . . . . .	N 5160
Tip Region Heat Transfer . . . . .	G NAG3-623		
Impingement Cooling . . . . .	G NSG3-075		
Computation of Turbine Blade Heat Transfer . . . . .	G NAG3-579		

Notes: A, B            Activities in series  
I, II, III            Activities in parallel

## BROAD IMPACT OF HOST PROJECT

The HOST Project met all the objectives in the NASA long-range aeronautics plan, including

(1) Recognition of the importance of NASA Aeronautics to both civil and military aviation. Ivan Bush stated before his recent retirement from the AFAPL "The Air Force looks to the HOST Project for the technology required in advanced fighters."

(2) Providing the U.S. with improved capability for R&T. State-of-the-art test facilities have been built at Lewis and at certain universities. Lewis has established an international leadership in constitutive modeling of materials behavior under complex thermomechanical loading.

(3) Restoring a balanced aeropropulsion program between performance improvement and durability; that is EEE, ATP, QCSEE Programs versus HOST.

(4) Strengthening the NASA-university partnership in aeronautics R&T. The HOST Project initiated 13 direct grants and approximately 26 indirect grants through industry. Also, Robert Henderson from the AFAPL stated "HOST improved the relationship between the government - NASA and the Air Force - and universities."

(5) Strengthening user interfaces to promote technology transfer. The HOST Project was responsible for 250 technical publications including six NASA Conference Publications, six major workshops and numerous miniworkshops, and dedicated HOST sessions at AIAA and ASME society meetings.

The HOST Project spearheaded a change from the traditional "build 'em and bust 'em" approach to turbine engine development to analytical predictions made before building hardware. These predictions were based on improved and more accurate mathematical models, computer codes, and broad experimental databases. Some results from this change in approach include

- (1) Improved durability in advanced hot sections
- (2) Reduced development time and costs
- (3) More accurate trade-off between performance and durability.

Research supported and focused by HOST improved quantitative accuracy to predict physical behavior of hot section parts under complex cyclic loading. The project efforts

- (1) Developed better understanding and modeled more accurately basic physics of durability phenomena;
- (2) Emphasized local as well as global conditions and responses;
- (3) Accommodated nonlinear and inelastic behavior;
- (4) Expanded some models from two to three-dimensions.



N88-15805

35-07  
10050  
16P.

## OVERVIEW OF NASA PTA PROPAN FLIGHT TEST PROGRAM

Edwin J. Graber

### ABSTRACT

During the last several years high-speed propellers have made the transition from a wind tunnel curiosity to a very likely near-term, fuel-efficient propulsion system that could revolutionize the subsonic commercial air transport industry. A key ingredient in this remarkable progress is the advanced turboprop program. Working together, NASA and industry have developed and flight tested two propeller propulsion systems to provide answers to key technical questions and concerns. An industry team is currently developing a third propeller propulsion system for flight testing late this year. This is a report on the progress of one of the NASA-industry flight test programs, called the Propfan Test Assessment (PTA) Program. Lockheed-Georgia is the prime contractor for PTA with Allison, Hamilton Standard, Rohr, Gulfstream, and Lockheed-California serving as major subcontractors. In PTA, a 9-ft-diameter propfan has been installed on the left wing of a Gulfstream GII executive jet and is undergoing extensive flight testing at Dobbins Air Force Base to evaluate propfan structural integrity, near- and far-field noise, and cabin interior noise characteristics. This research testing includes variations in propeller tip speed and power loading, nacelle tilt angle, and aircraft Mach number and altitude. As a result, extensive parametric data will be obtained to verify and improve computer codes for predicting propeller structural aeroelastic, aerodynamic, and acoustic characteristics. Over 600 measurements are being recorded for each of approximately 600 flight test conditions.

MAJOR CONTRACTUAL ELEMENTS OF ATP

The Advanced Turboprop Project (ATP) has four major contractual elements. The Large-Scale Advanced Propeller Program (LAP) is a contract with Hamilton Standard for the design, fabrication, and checkout of a 9-ft-diameter advanced propfan. Under the Propfan Test Assessment (PTA) Program contract with Lockheed-Georgia, the LAP-provided propfan is being flight tested on a Gulfstream GII aircraft. In a third element, General Electric developed and static tested a unique gearless counter-rotation propfan engine called the Unducted Fan (UDF). Finally, both Pratt & Whitney and Allison were contracted to design, build, and test advanced high-horsepower counterrotation gearboxes.

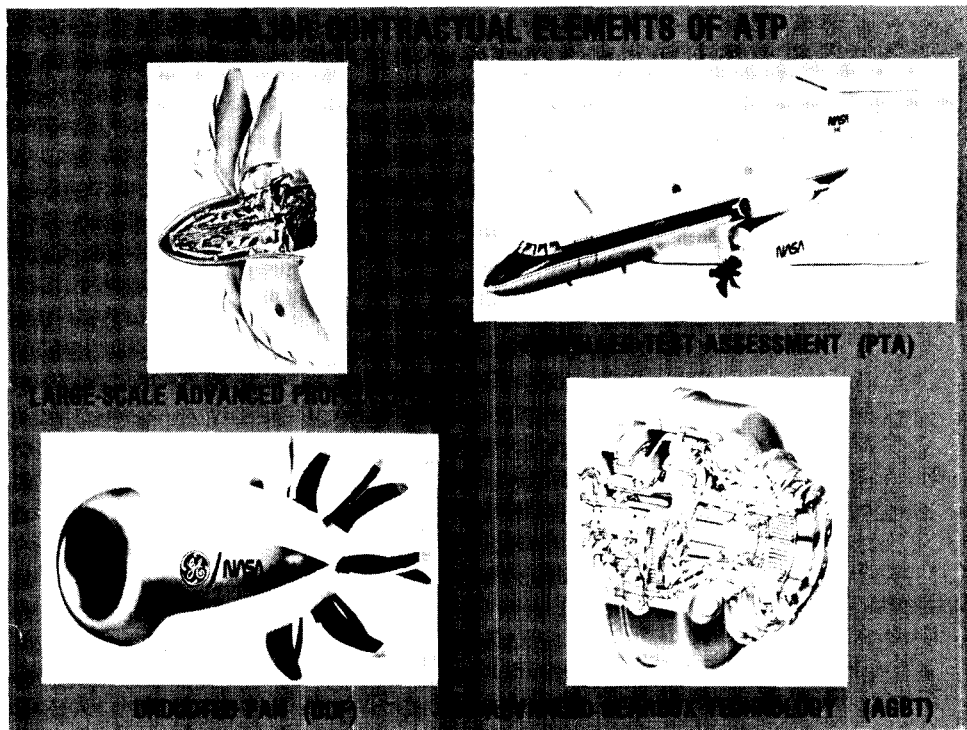

CD-87-28790

ORIGINAL PAGE IS  
OF POOR QUALITY

### LAP PROJECT

Under the LAP project, Hamilton Standard recently completed testing of the large-scale advanced propfan in France's Modane wind tunnel to verify blade structural integrity and to acquire blade steady and unsteady pressure data for verifying and improving aerodynamic prediction codes. Both a primary and backup propfan were delivered to the PTA flight test program.

## LAP PROJECT



**TWO-BLADE  
SR-7 IN MODANE,  
FRANCE, WIND  
TUNNEL**

### TRANSDUCER LOCATIONS

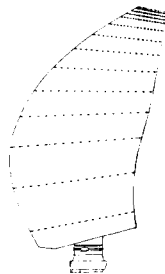

**STEADY PRESSURE**

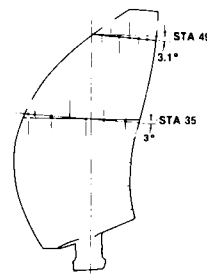

**UNSTEADY PRESSURE**

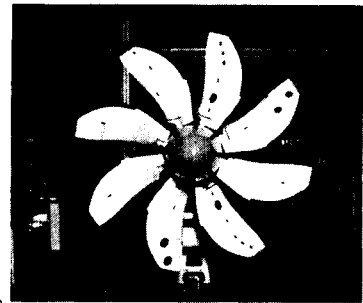

**TWO SR-7  
ASSEMBLIES  
DELIVERED  
TO PTA**

### INSTRUMENTATION FOR MODANE TESTING

CD-87-28791

## NASA/GE UNDUCTED FAN (UDF)

The NASA/GE unducted fan (UDF) was checked out on the GE Peebles, Ohio, static test stand before being flight tested on the Boeing 727 from August 1986 through February 1987 and on the Douglas MD-80 from May 1987 through late 1987.

## NASA/GE UNDUCTED FAN (UDF)

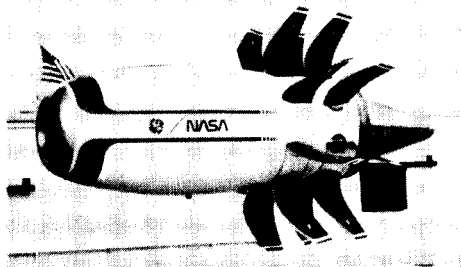

**GE STATIC TEST AT PEBBLES, OHIO**

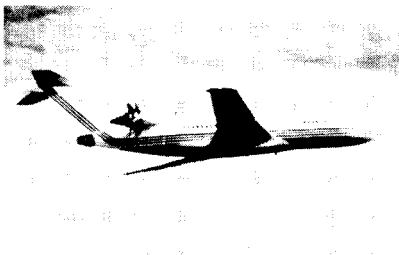

**BOEING 727 FLIGHT  
TEST**

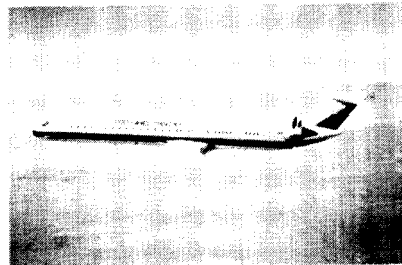

**DOUGLAS MD-80  
FLIGHT TEST**

CD-87-28792

ORIGINAL PAGE IS  
OF POOR QUALITY

**ORIGINAL PAGE IS  
OF POOR QUALITY**

## ADVANCED COUNTERROTATION GEARBOX SYSTEMS

In the Advanced Gearbox Program Allison has designed, fabricated, and tested a high-power advanced counterrotation gearbox. Allison used the results of these tests in developing the gearbox for the P&W Allison and Douglas 578DX/MD-80 flight test program.

## ADVANCED COUNTERROTATION GEARBOX SYSTEMS

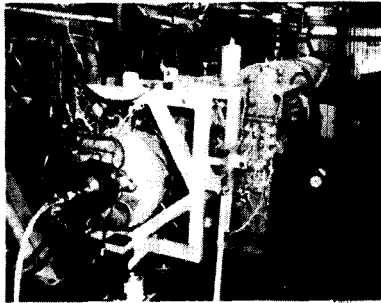

- **ALLISON CONTRACT**
- **COUNTERROTATING IN-LINE DIFFERENTIAL PLANETARY GEAR SYSTEM**
- **13 000-shp CLASS**
- **99 PERCENT EFFICIENCY**
- **DURABILITY GOAL OF 30 000-hr MTBR**

CD-87-28793

## FLIGHT TESTING OF ADVANCED TURBOPROPS

In four major flight test programs high-speed propellers either have been or will be flight tested within a 1-1/2-year time span. GE and Boeing led the way in August 1986 with flight tests of the UDF propulsion system on the Boeing 727 aircraft. NASA and Lockheed followed shortly thereafter with flight testing of the PTA aircraft in March 1987. In May 1987, GE combined with Douglas Aircraft to flight test the UDF propulsion system on the Douglas MD-80 aircraft. Later this year the United Technologies, Allison, and Douglas flight test program is scheduled to begin.

## FLIGHT TESTING OF ADVANCED TURBOPROPS



**PTA/GULFSTREAM GII**



**UDF/BOEING 727**



**UDF/MD-80 AND  
578DX/MD-80**

CD-87-28794

# PROPFAN TEST ASSESSMENT (PTA) OBJECTIVES

EVALUATE THROUGH THE DEVELOPMENT OF A FLIGHTWORTHY DRIVE SYSTEM AND SUBSEQUENT GROUND AND FLIGHT TESTING OF A LARGE-SCALE PROPFAN

- PROPFAN STRUCTURAL INTEGRITY
- PROPFAN SOURCE NOISE
- ASSOCIATED PROPFAN-RELATED CABIN NOISE AND VIBRATION
- FAR-36 COMMUNITY NOISE
- ENROUTE CRUISE NOISE (GROUND)

CD-87-28795

## PTA SCHEDULE

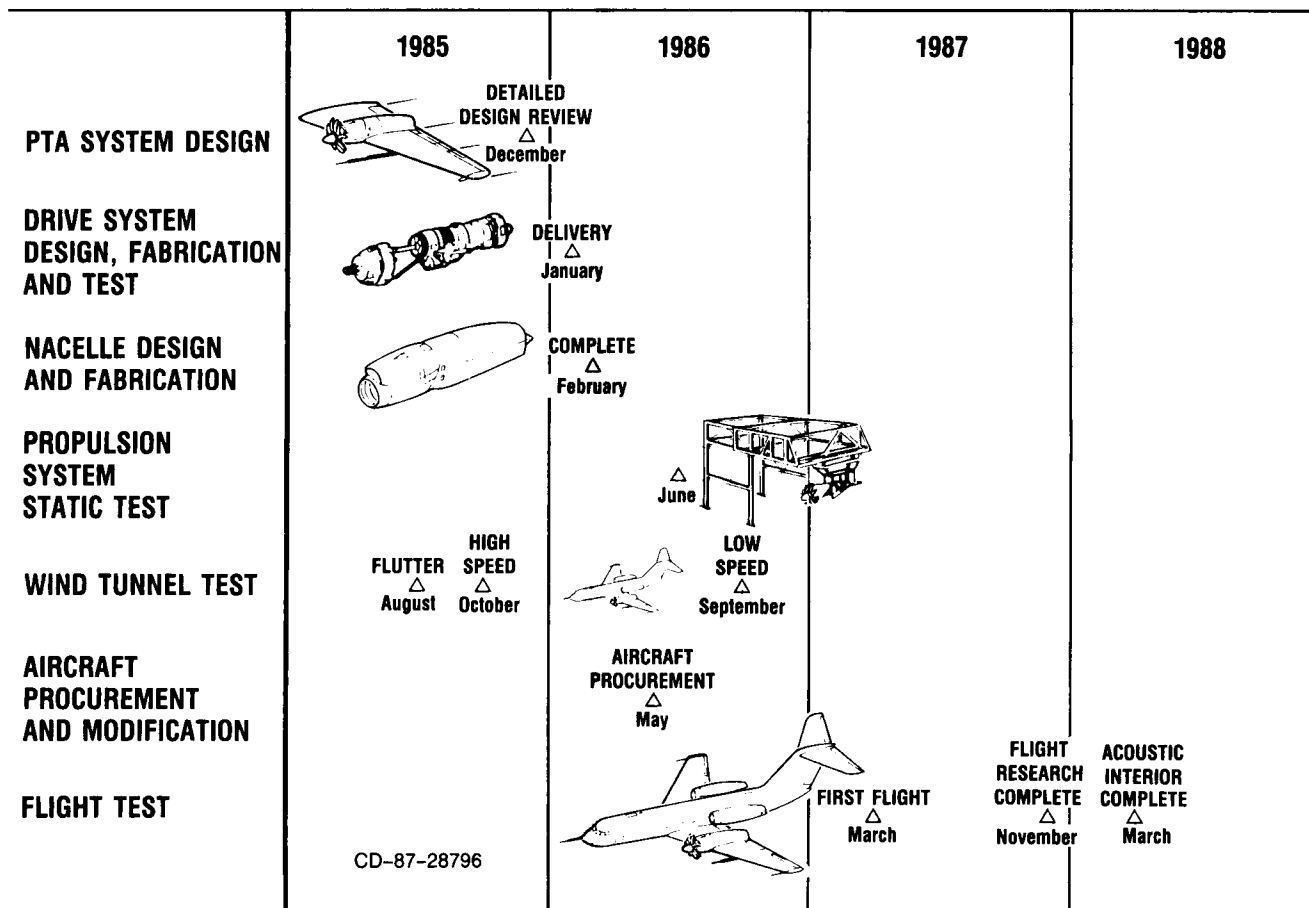

PTA TEAM MEMBERS

The PTA program was a team effort involving several NASA centers, Lockheed-Georgia as the prime contractor, and five major subcontractors.

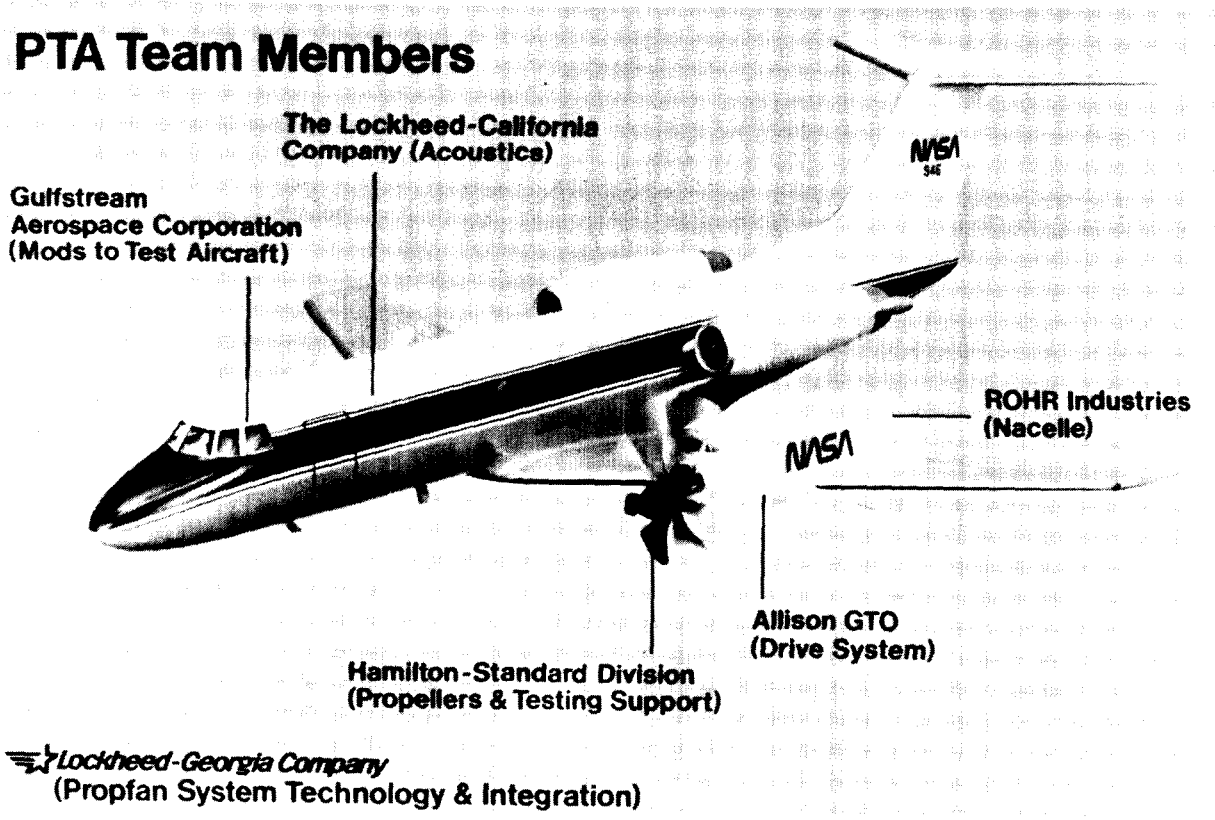

CD-87-28797

ORIGINAL PAGE IS  
OF POOR QUALITY



## AIRCRAFT MODIFICATIONS

To accomplish the PTA flight testing, the Gulfstream GII was extensively modified. In addition to the modifications illustrated in this figure, a 700-lb armor plate was installed to protect the fuselage in the event of a blade failure during the initial phases of testing.

## AIRCRAFT MODIFICATIONS

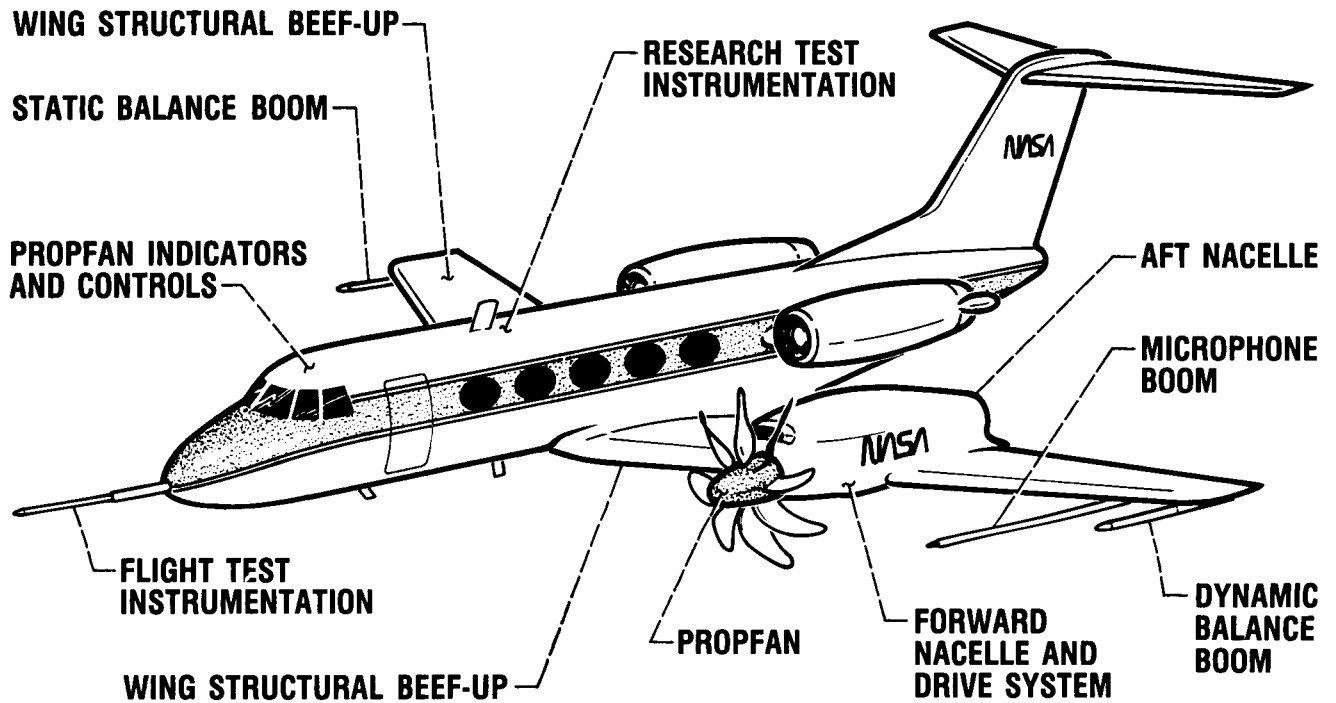

CD-87-28798

## RESEARCH INSTRUMENTATION

Over 600 pieces of instrumentation were installed on the PTA aircraft for assessing propfan structural integrity, source noise, and associated cabin noise and vibration characteristics.

### RESEARCH INSTRUMENTATION (613 PARAMETERS)

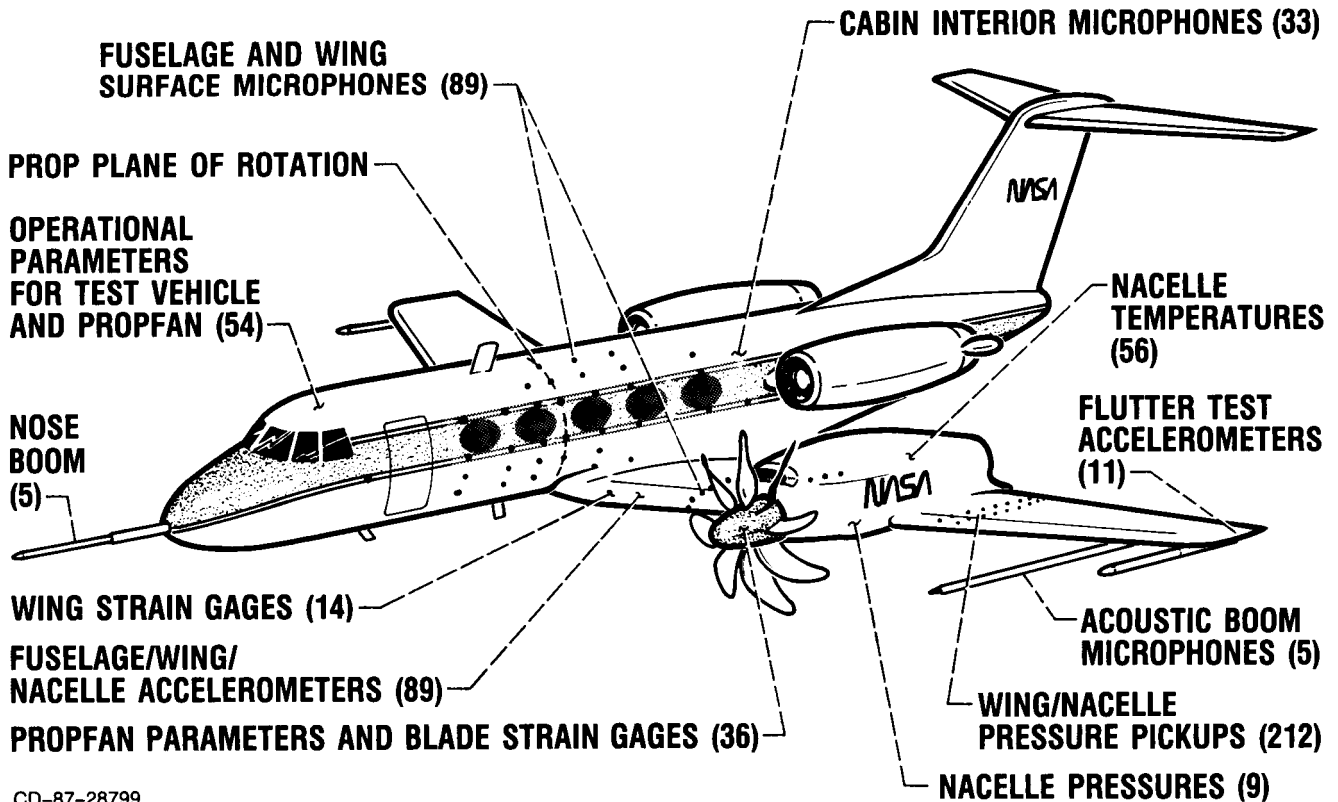

CD-87-28799

## NACELLE TILT RANGE

To evaluate propfan structural integrity with respect to aerodynamic inflow excitation, a unique tiltable nacelle was used. Tilts of 2° up, 1° down, and 3° down were accomplished by changing forward-to-aft nacelle attachment fittings.

## NACELLE TILT RANGE

2° UP  
1° DOWN—NOMINAL  
3° DOWN

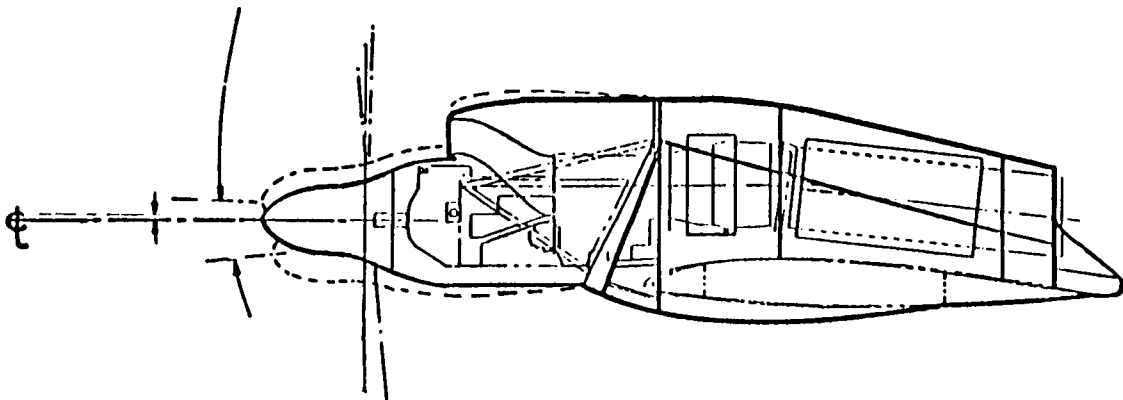

CD-87-28800

## PREDICTED PROPFAN EXCITATION FACTORS

The nacelle tilts were selected to allow testing over a range of propfan excitation factors from approximately 2 to 4.5.

## PREDICTED PROPFAN EXCITATION FACTORS

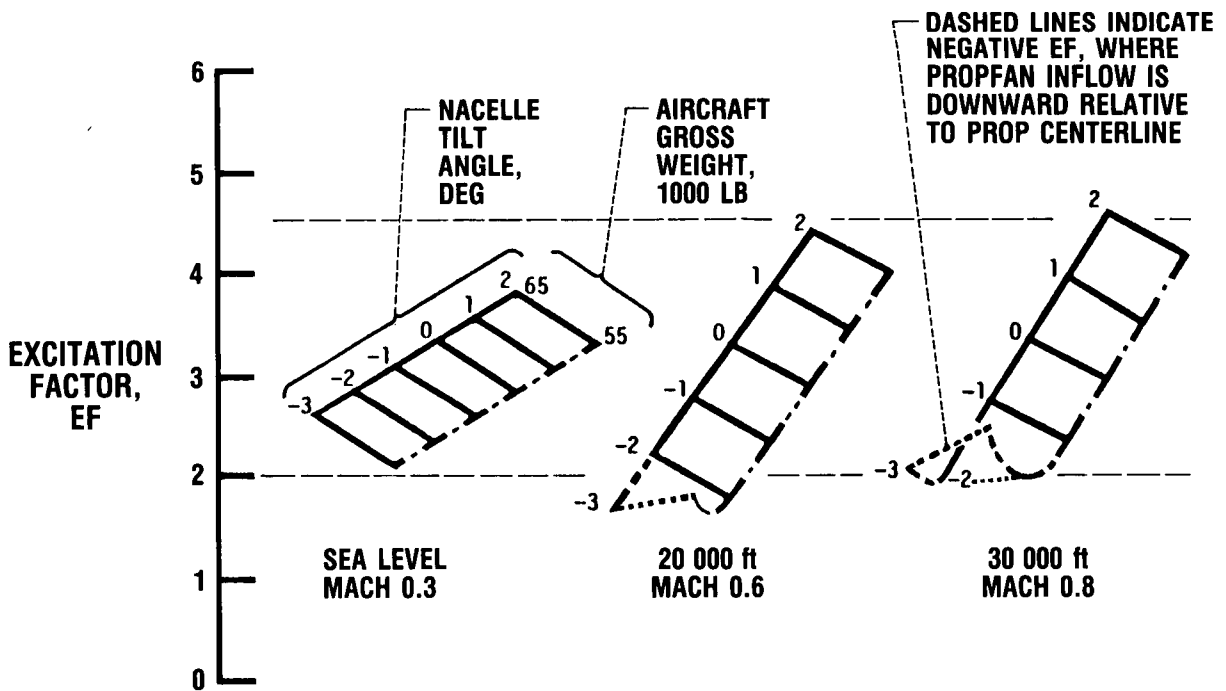

CD-87-28801

## SCALE-MODEL TESTING

Several scale-model tests were conducted to help ensure a safe flight test program and to obtain data for validating aerodynamic prediction codes.

ORIGINAL PAGE IS  
OF POOR QUALITY

## SCALE-MODEL TESTING

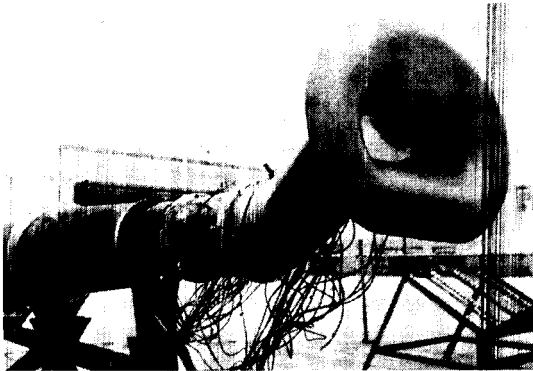

**1/3-SCALE INLET**

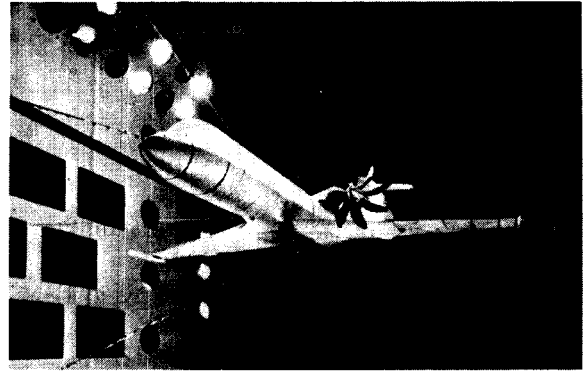

**1/9-SCALE FLUTTER**

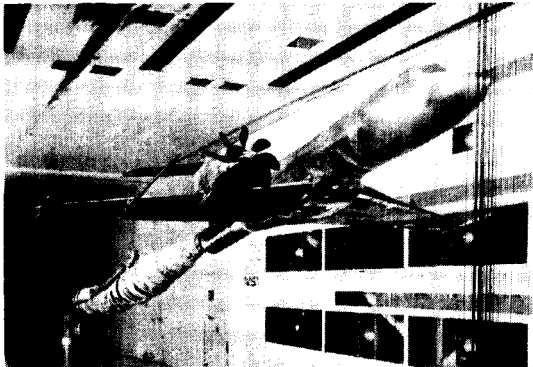

**1/9-SCALE STABILITY, CONTROL, AND PERFORMANCE**

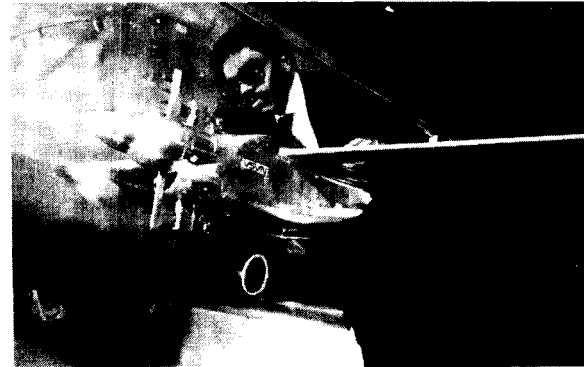

**1/9-SCALE PROP FLOWFIELD**

CD-87-28802

## GROUND TESTING

Because the gearbox and power section had to be modified to power the advanced propfan, these components were checked out in ground test facilities before being assembled with the propfan for static testing at Rohr's Brown Field facility. Propulsion system operability and function were confirmed in the 50-hr static test at Rohr.

## GROUND TESTING

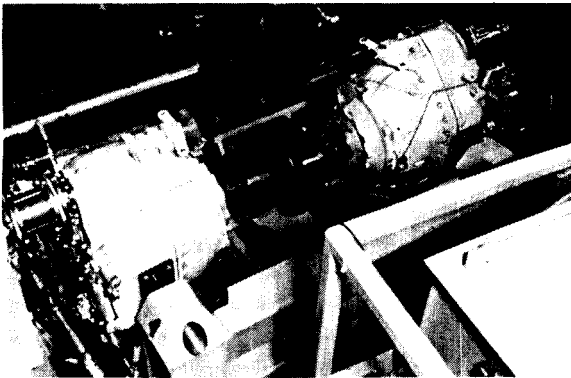

**GEARBOX ENDURANCE**

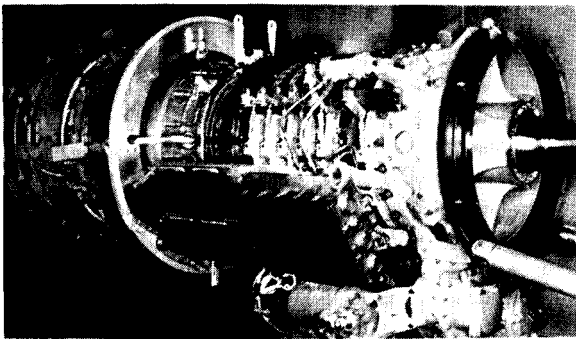

**ENGINE DURABILITY**

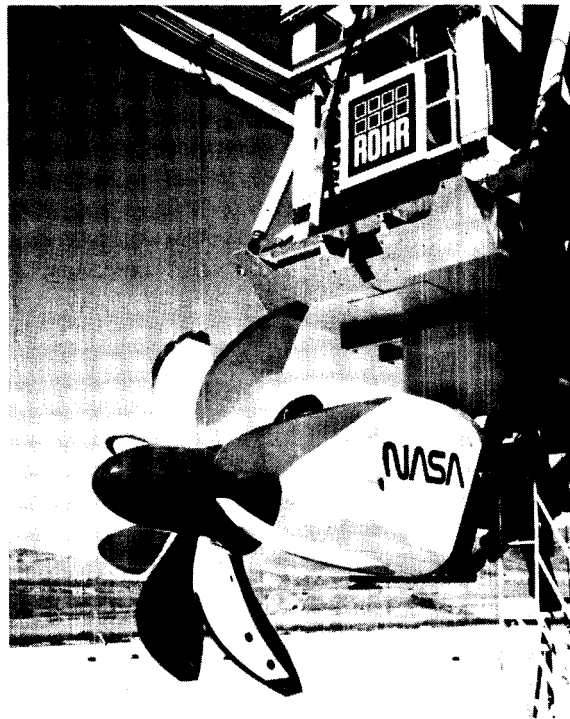

**PROPULSION SYSTEM STATIC TEST**

CD-87-28803

ORIGINAL PAGE IS  
OF POOR QUALITY

ORIGINAL PAGE IS  
OF POOR QUALITY

### STAGES OF AIRCRAFT MODIFICATION

The serial number 118 Gulfstream GII aircraft is shown as purchased and at various stages of modification. Modification was done at Gulfstream Aerospace in Savannah, Georgia.

## AIRCRAFT MODIFICATIONS

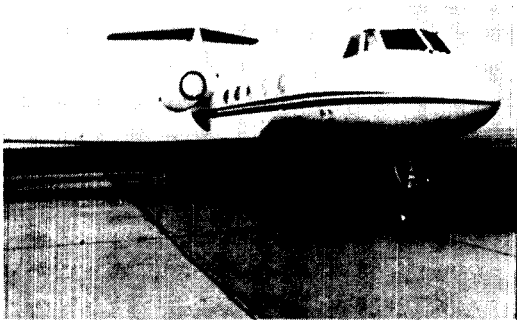

**SERIAL NO. 118 GII**

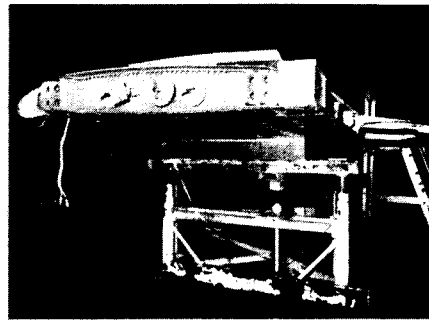

**WING BEEF-UP**

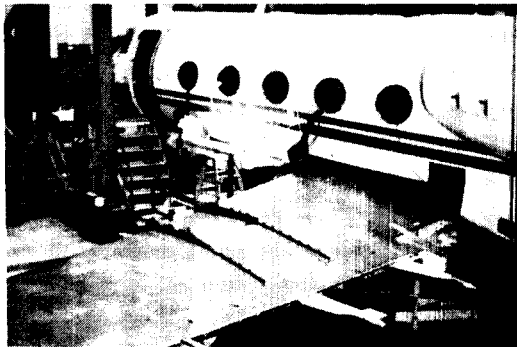

**WING-TO-FUSELAGE ATTACHMENT**



**NACELLE ON WING**

CD-87-28804

## PTA FLIGHT TESTING

After aircraft modification and checkout testing, flight testing begun in March 1987. The first tests were conducted with the propfan removed to establish safe aircraft operation before proceeding with prop-on testing in April 1987. Prop-on testing was done at the Lockheed-Georgia facility at Dobbins Air Force Base.

## PTA FLIGHT TESTING BEGUN IN MARCH 1987

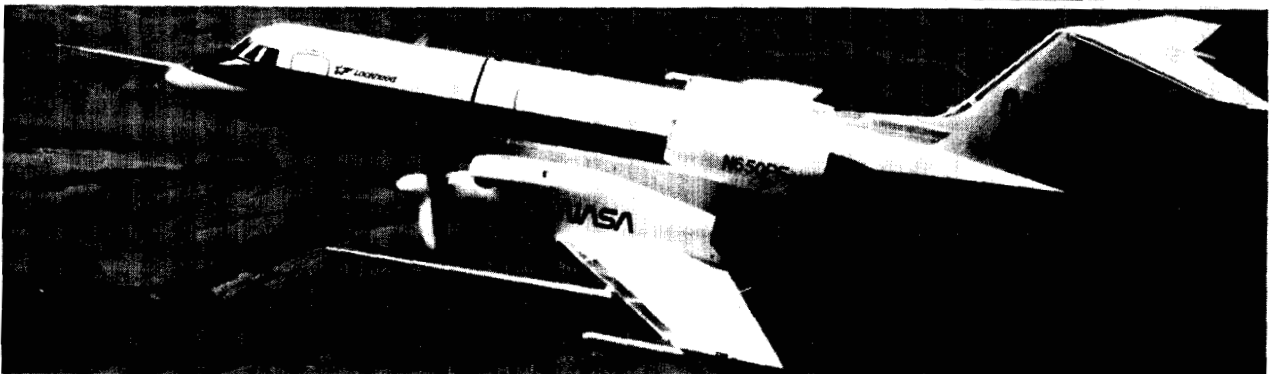
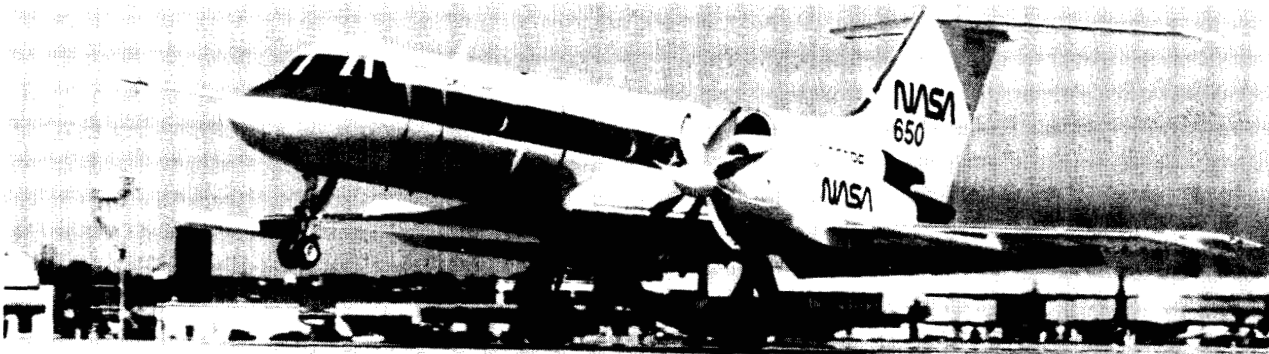

CD-87-28805

ORIGINAL PAGE IS  
OF POOR QUALITY.



## PTA FLIGHT TEST PROGRAM

The flight test program was sequenced to minimize risk. All systems were checked out on the ground before proceeding with flight testing. Airworthiness testing was then conducted to verify safe operation before starting the actual research flight tests.

## PTA FLIGHT TEST PROGRAM

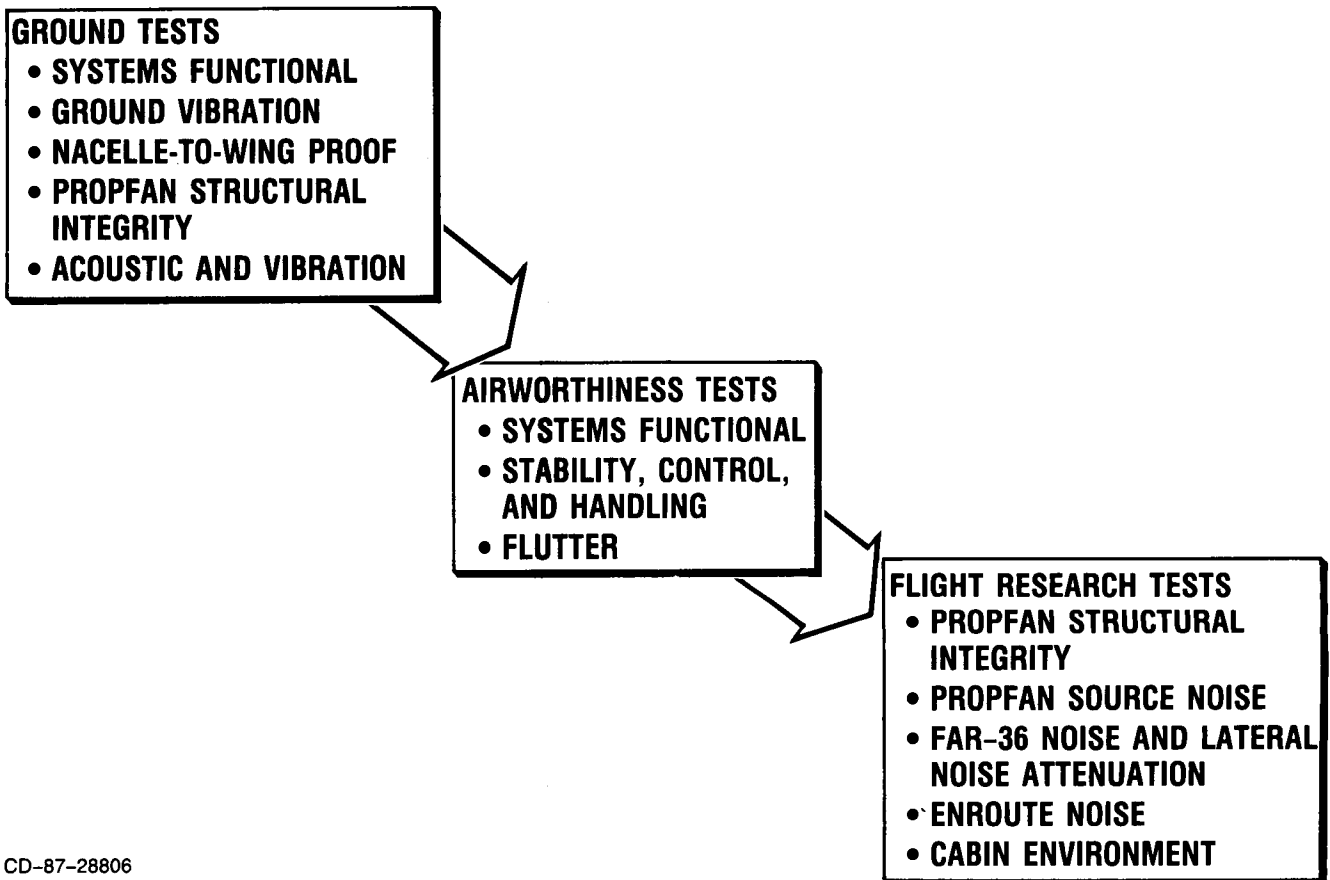

CD-87-28806

## FLIGHT TEST ENVELOPE

Over 500 flight test points have been recorded in the high-altitude research flight test matrix. In addition to the altitude and Mach number variations shown, propfan tip speed, propfan power loading, and nacelle tilt angle were also varied.

## FLIGHT TEST ENVELOPE

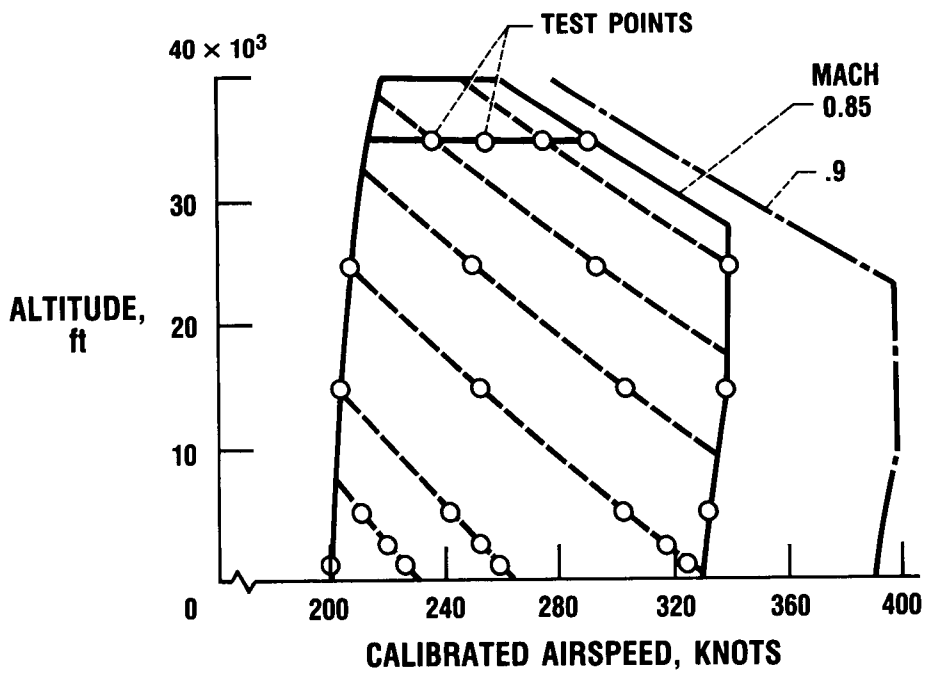

CD-87-28807

INSTALLED SR-7 PROPFAN

Forty-six strain gages were installed on the propfan with 30 of these gages continuously recording during the flight test program.

ORIGINAL PAGE IS  
OF POOR QUALITY

**INSTALLED SR-7 PROPFAN**

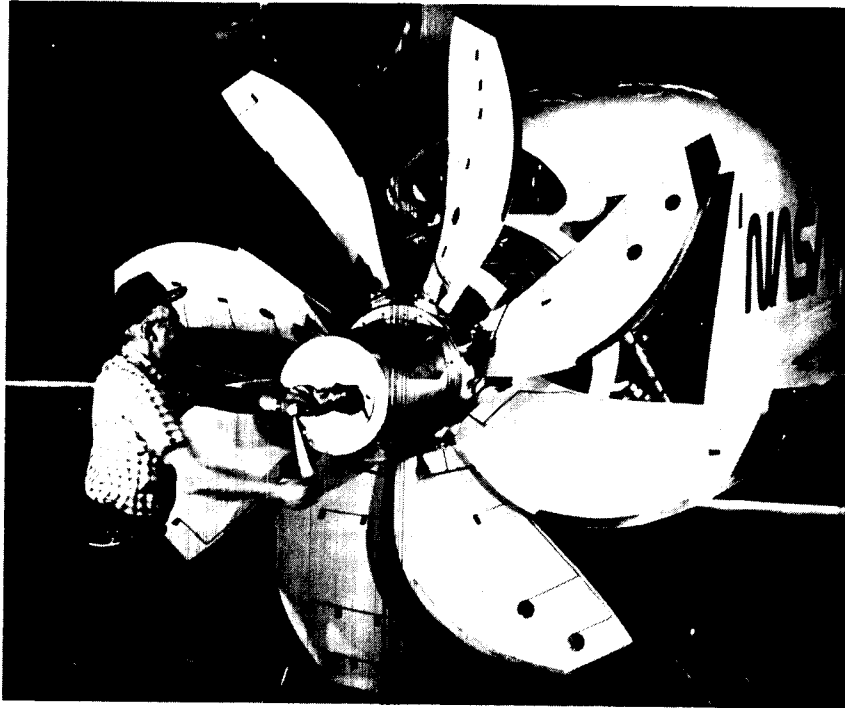

CD-87-28808

## PROPFAN IN-FLIGHT STRESS

Propfan stresses were consistently below the infinite life limit throughout flight testing.

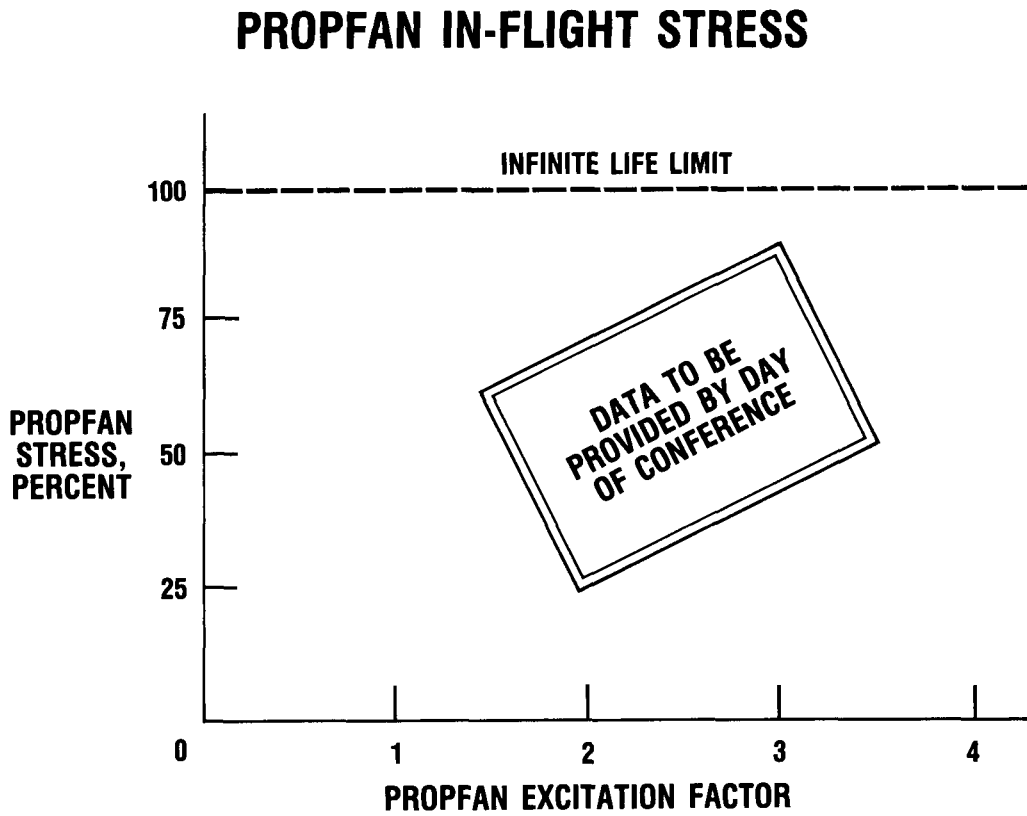

CD-87-28809

## FUSELAGE SURFACE MICROPHONES

External fuselage surface microphones were installed fore and aft of the propfan plane to map source noise characteristics.

## FUSELAGE SURFACE MICROPHONES

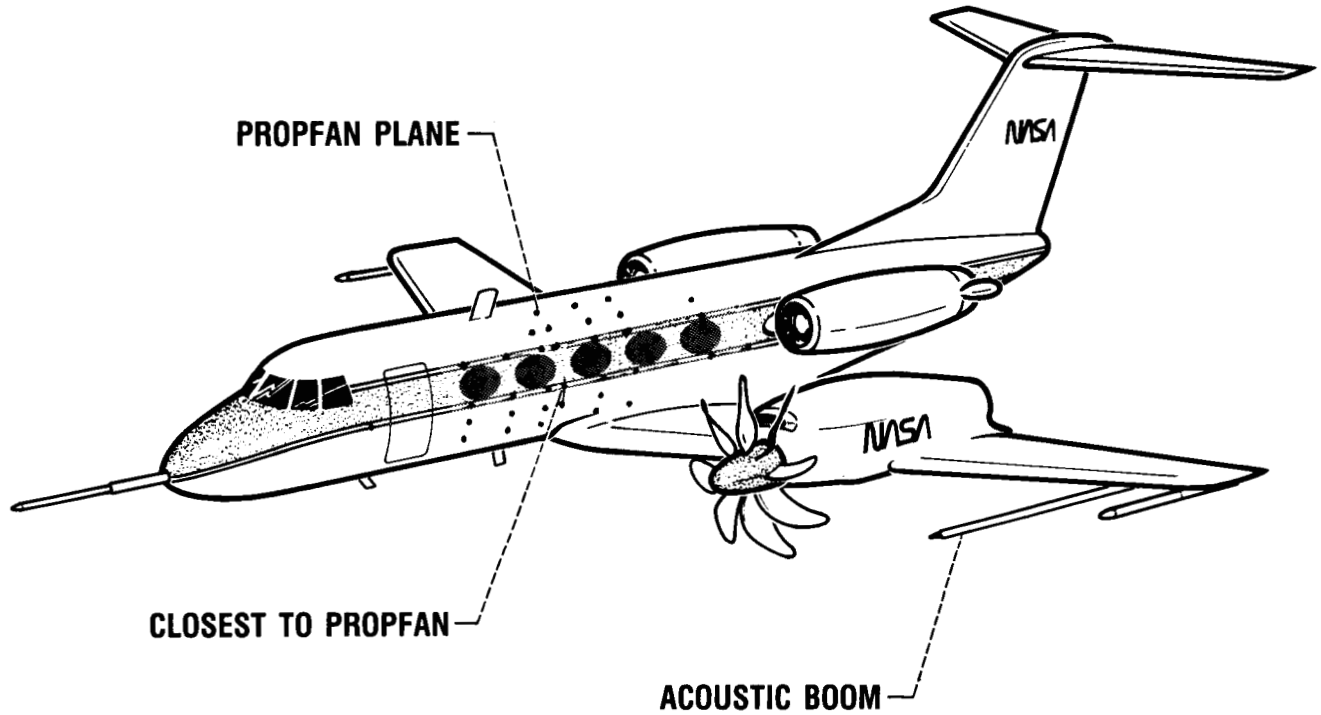

CD-87-28810

## FUSELAGE EXTERIOR NOISE

Initial flight test data agree favorably with both scaled-up data from Lewis' 8- by 6-Foot Wind Tunnel and predictions using an early Hamilton Standard analytical prediction code.

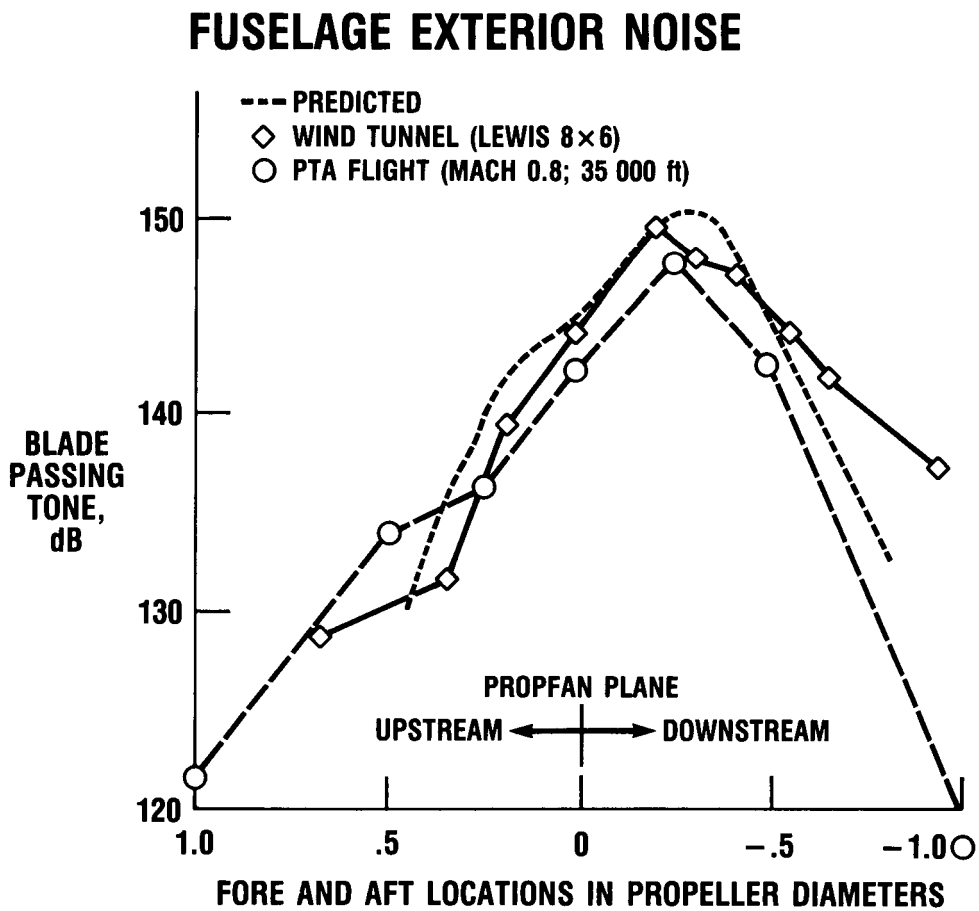

## COMMUNITY NOISE TESTING

Community noise data were obtained at the NASA Wallops Flight Facility in September and October of this year. Testing was conducted at altitudes of 850, 1000, 1300, and 1600 ft with the aircraft flying in both north-south and south-north directions. The matrix of test points included variations in propfan tip speed and power level with all testing conducted at an aircraft speed of 195 knots.

### COMMUNITY NOISE TESTING NASA WALLOPS FLIGHT FACILITY

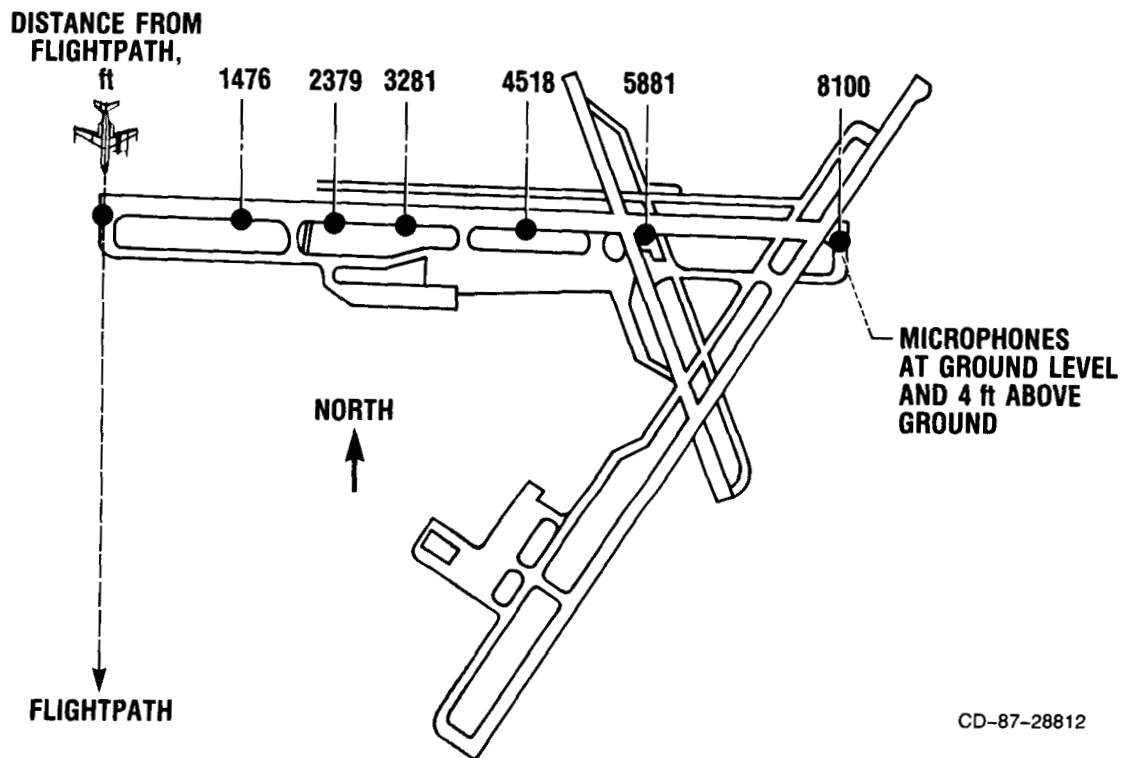

CD-87-28812

## ENROUTE NOISE TESTING

After the community noise testing a NASA/FAA cooperative enroute noise test was conducted in October 1987. In these tests the NASA Learjet was used to map out the acoustic field approximately 500 ft below and to the side of the PTA aircraft. The T-38 was used as an observer for flight safety. After mapping the acoustic field at altitudes of 20 000 and 35 000 ft and speeds of Mach 0.7 and 0.8, respectively, the PTA aircraft was flown over a microphone array to record noise levels reaching the ground. Before and after each flight test day, a weather balloon was launched to measure atmospheric conditions from sea level to the test altitude. Results of these tests will be used to verify and improve codes for predicting noise transmission characteristics through the atmosphere.

## ENROUTE NOISE TESTING COOPERATIVE NASA/FAA PROGRAM

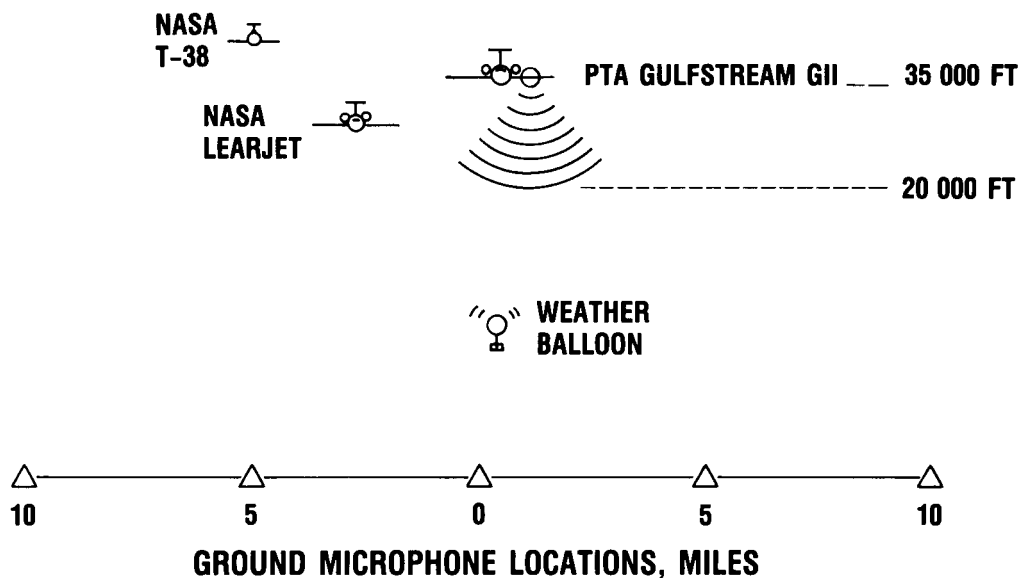

CD-87-29512



## CABIN NOISE TESTING

A 10-ft section of the aircraft has been cleared for acquiring data on cabin noise characteristics. During testing to date, data have been acquired for a "bare wall" cabin. In February and March 1988 an experimental advanced cabin acoustic treatment will be installed and flight tested over a range of repeat test points. This treatment will be designed and fabricated as part of a NASA Langley contract with Lockheed-California. The results of this test will provide the critical correlation between ground-based and flight test results.

## CABIN NOISE TESTING

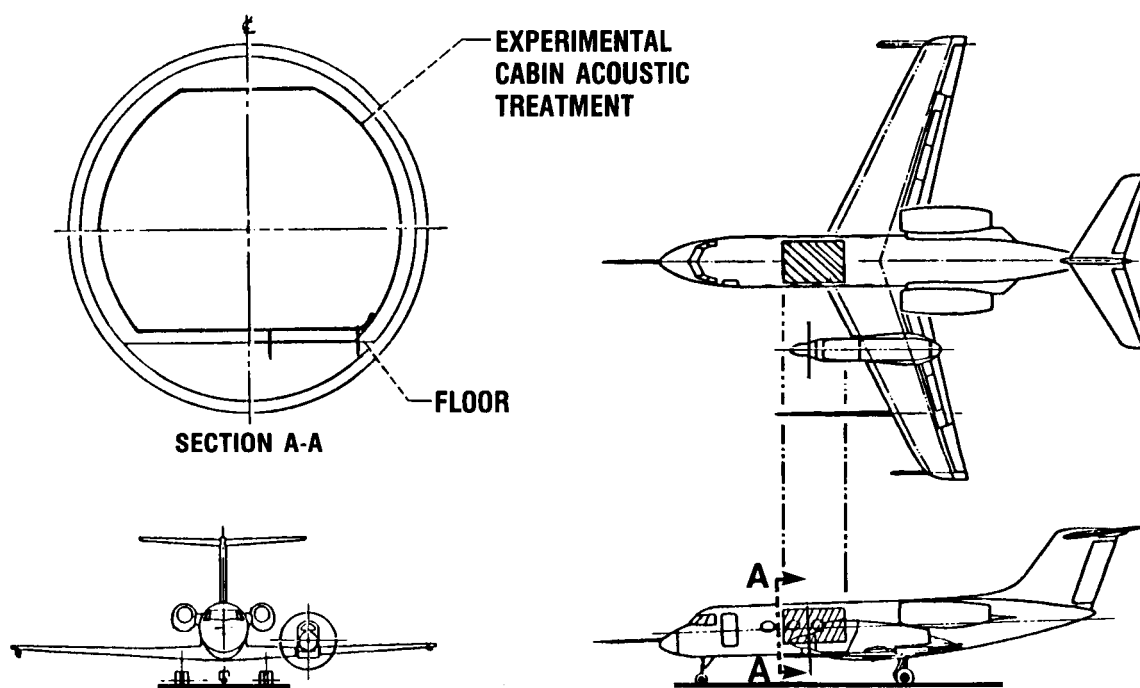

CD-87-28813

## **SUMMARY**

- **PTA FLIGHT TESTING NEARING COMPLETION**
  - **OVER 600 MEASUREMENTS**
  - **OVER 500 HIGH-ALTITUDE FLIGHT TEST CONDITIONS**
    - **PROPFAN TIP SPEED FROM 600 TO 840 ft/sec**
    - **PROPFAN POWER FROM MINIMUM TO 100 PERCENT**
    - **THREE NACELLE TILTS (TO VARY EXCITATION FACTOR)**
    - **SPEED TO MACH 0.89**
    - **ALTITUDES FROM 2000 TO 40 000 ft**
  - **COMMUNITY NOISE DATA OBTAINED AT NASA WALLOPS FLIGHT FACILITY**
  - **ENROUTE NOISE DATA OBTAINED**

CD-87-28814

## **CONCLUSIONS**

- **PROPFAN STRUCTURAL AND AEROELASTIC RESPONSE IN GOOD AGREEMENT WITH PREDICTIONS**
- **NEAR-FIELD NOISE PREDICTED VERY WELL AND IN GOOD AGREEMENT WITH WIND TUNNEL TESTS ON SUBSCALE MODELS**
- **COMMUNITY NOISE TEST DATA BEING ANALYZED BY NASA AND LOCKHEED**
- **FAA AND NASA USING ENROUTE NOISE DATA TO VALIDATE ATMOSPHERIC ATTENUATION CODES**
- **INTERIOR NOISE TESTS PLANNED FOR MARCH 1988**

CD-87-28815

56-07  
N88-15806 118081  
308

## ADVANCED PROPELLER RESEARCH

John F. Groeneweg  
and  
Lawrence J. Bober

### ABSTRACT

Recent results of aerodynamic and acoustic research on both single and counter-rotation propellers are reviewed. Data and analytical results are presented for three propellers: SR-7A, the single rotation design used in the NASA Propfan Test Assessment (PTA) flight program; CRP-X1, the initial 5+5 Hamilton Standard counter-rotating design; and F7-A7, the 8+8 counterrotating General Electric design used in the proof-of-concept Unducted Fan (UDF) engine. In addition to propeller efficiencies, cruise and takeoff noise, and blade pressure data, off-design phenomena involving formation of leading edge vortices are described. Aerodynamic and acoustic computational results derived from three-dimensional Euler and acoustic radiation codes are presented. Research on unsteady flows, which are particularly important for understanding counterrotation interaction noise, unsteady loading effects on acoustics, and flutter or forced response is described. The first results of three-dimensional unsteady Euler solutions are illustrated for a single rotation propeller at angle of attack and for a counter-rotation propeller. Basic experimental and theoretical results from studies of the unsteady aerodynamics of oscillating cascades are outlined. Finally, advanced concepts involving swirl recovery vanes and ultra bypass ducted propellers are discussed.

## OUTLINE

The material in this presentation addresses three aspects of propeller research, analysis, verification of the analysis with experiment, and studies of advanced concepts, and is covered in four major divisions. Single rotation and counter-rotation technology address cruise performance, noise at both cruise and takeoff, and other topics including blade pressure measurements, flow phenomena associated with off-design operation, and steady Euler analyses. In the area of unsteady aerodynamics, recent unsteady three-dimensional Euler results are shown along with theoretical and experimental results from work on transonic cascades. Finally, advanced concepts and the future work to address them are discussed.

## OUTLINE

- **SINGLE ROTATION TECHNOLOGY**
- **COUNTERROTATION TECHNOLOGY: GEARED & GEARLESS**
- **UNSTEADY AERODYNAMICS**
- **ADVANCED CONCEPTS—FUTURE WORK**

CD-87-29480

## ADVANCED PROPELLER DESIGN PARAMETERS

Recent wind tunnel tests have provided data on these models of advanced high-speed propellers. The SR-7 is the most recent of a series of single rotation designs and is a scale model of the propeller being used in the Propfan Test Assessment (PTA) Flight Program. The F7-A7 is a scale model of the counterrotation pusher propeller being used on the unducted fan (UDF) demonstrator engine. The CRP-X1 model simulates a counterrotation tractor propeller. The nominal diameter of all these models is 2 ft.

## ADVANCED PROPELLER DESIGN PARAMETERS

	NUMBER OF BLADES	RADIUS RATIO	CRUISE MACH NUMBER	CRUISE LOADING, shp/D <sup>2</sup>	TIP SPEED, ft/sec
SR-7	8	0.24	0.80	32.0	800
F7-A7	8+8	0.425	0.72	55.5	780
CRP-X1	5+5	0.240 0.275	0.72	37.2	750

CD-87-29481

ORIGINAL PAGE IS  
OF POOR QUALITY

### SR-7A PROPELLER IN LEWIS 8- BY 6-FT WIND TUNNEL

The propeller model, SR-7A, is an aeroelastically scaled model of the LAP propeller (SR-7L) which is being used in the PTA flight program. The model is shown in the NASA Lewis 8- by 6-foot wind tunnel, where it was tested for aerodynamic, acoustic, and aeroelastic performance. Also shown in the photograph are laser beams which were part of a system for measuring blade deflections during propeller operation.

### SR-7A PROPELLER IN LEWIS 8- BY 6- FT WIND TUNNEL

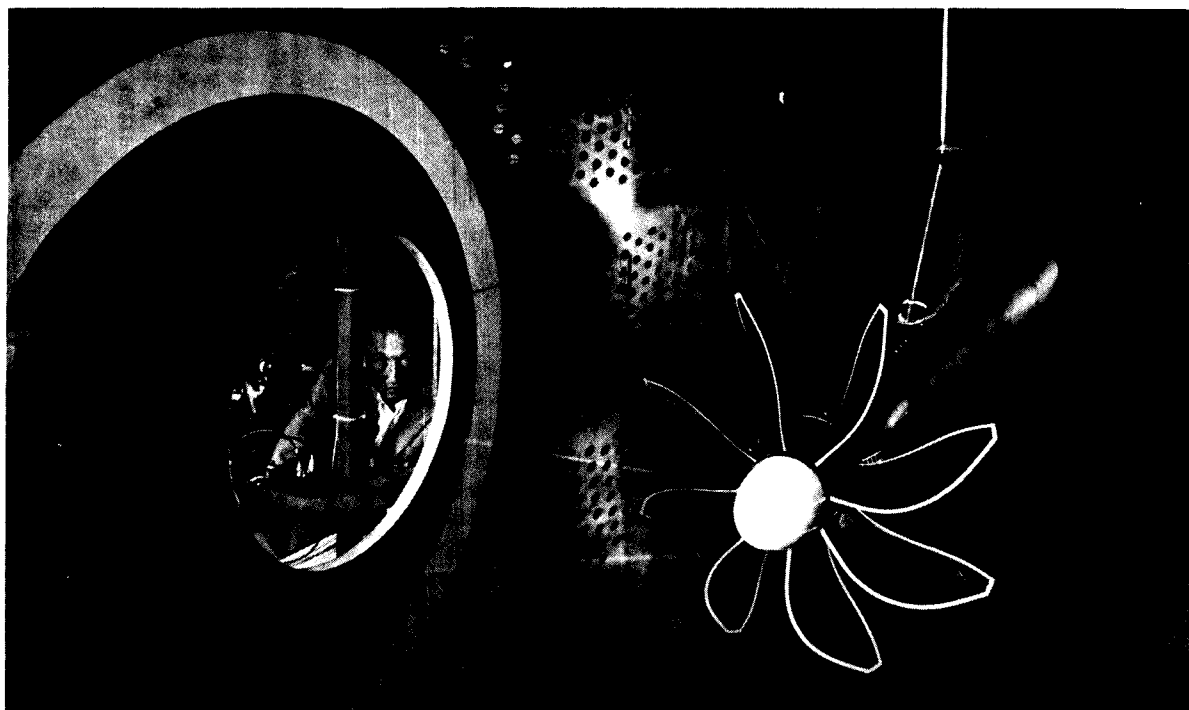

CD-87-29482

## SINGLE-ROTATION PROPELLER PERFORMANCE

Net efficiency of the SR-7 propeller model is shown along with results from five earlier models. The measured net efficiencies are shown as a function of Mach number with each propeller's design loading parameter  $C_p/J_3$  kept constant with Mach number. At Mach 0.80 the SR-7A propfan has the highest measured propeller efficiency of 79.3 percent. The performance of the SR-2 propeller is lower than the performance of the other propellers since it is the only one of these models which has no blade sweep. Important characteristics of these models are indicated below.

Design	Number of blades	Sweep angle, deg	Power coefficient, $C_p$	Advance ratio, J	Loading parameter, $C_p/J_3$
SR-7A	8	41	1.45	3.06	0.0509
SR-6	10	40	2.03	3.50	.0474
<sup>a</sup> SR-6	10	40	2.03	3.50	.0474
SR-3	8	45	1.70	3.06	.0593
SR-1M	8	30	1.70	3.06	.0593
SR-2	8	0	1.70	3.06	.0593

<sup>a</sup>Estimated performance with alternate spinner 2.

## SINGLE-ROTATION PROPELLER PERFORMANCE

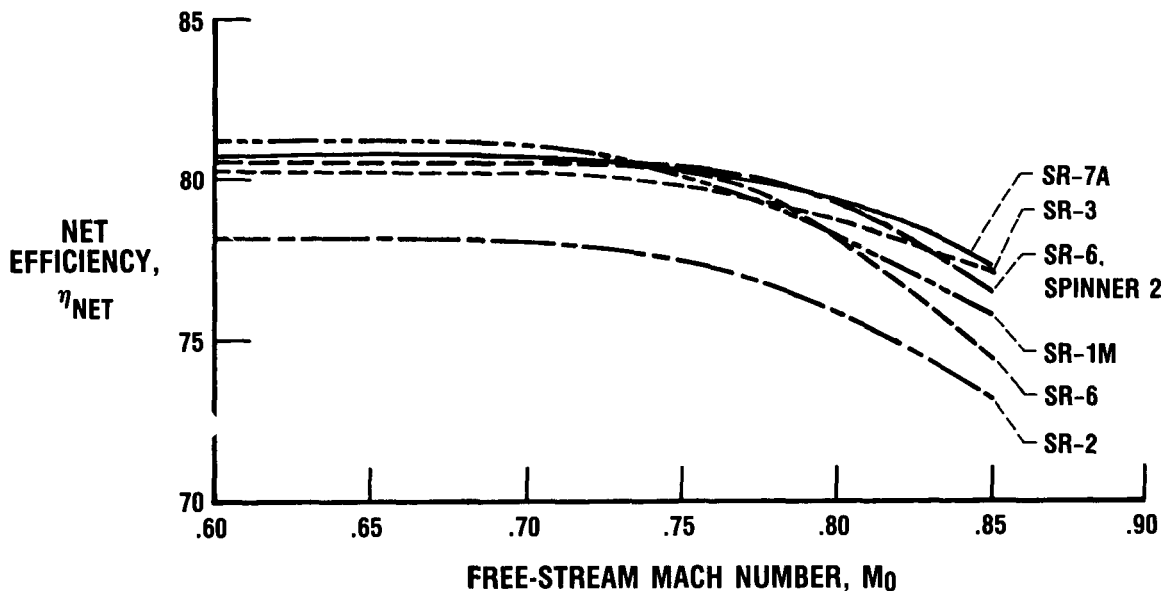

CD-87-29483

## SR-7 PEAK BLADE PASSING TONE VARIATION WITH HELICAL TIP MACH NUMBER

Peak fundamental tone levels are shown at constant advance ratio (3.06) for three loading levels as indicated by the blade setting angles bracketing the design value. The striking feature of the tone variation with helical tip Mach number is the behavior in the supersonic range beyond 1.1. The peak fundamental tone levels no longer increase and may peak, level off, or decrease depending on loading. This result indicates that higher cruise and propeller speeds do not necessarily mean increased cabin noise problems.

### SR-7 PEAK BLADE PASSING TONE VARIATION WITH HELICAL TIP MACH NUMBER CONSTANT ADVANCE RATIO, 3.06

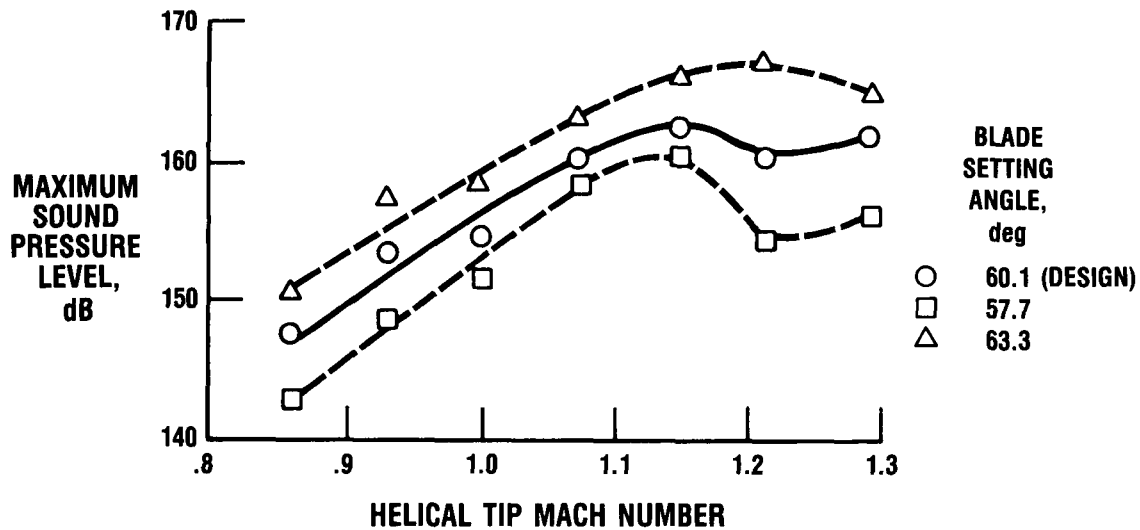

CD-87-29484



## SR-7A PROPELLER MODEL IN THE 9- BY 15-FT ANECHOIC WIND TUNNEL

The SR-7A propeller model is shown installed on a swept wing used to determine installation effects on community noise at typical takeoff and approach conditions (Mach 0.2). The entire propeller-wing assembly may be rotated to angle of attack in the horizontal plane. The continuously traversing microphones (at right) measure far-field noise corresponding to levels measured below an aircraft during flyover. Fixed microphones on the walls measure noise in the other three directions and are staggered with respect to the tunnel flow to avoid wake interference on downstream microphones. The walls are acoustically treated to provide anechoic conditions down to a frequency of 250 Hz, well below the fundamental frequency for the propeller model.

## SR-7A PROPELLER MODEL IN 9- BY 15-FT ANECHOIC WIND TUNNEL

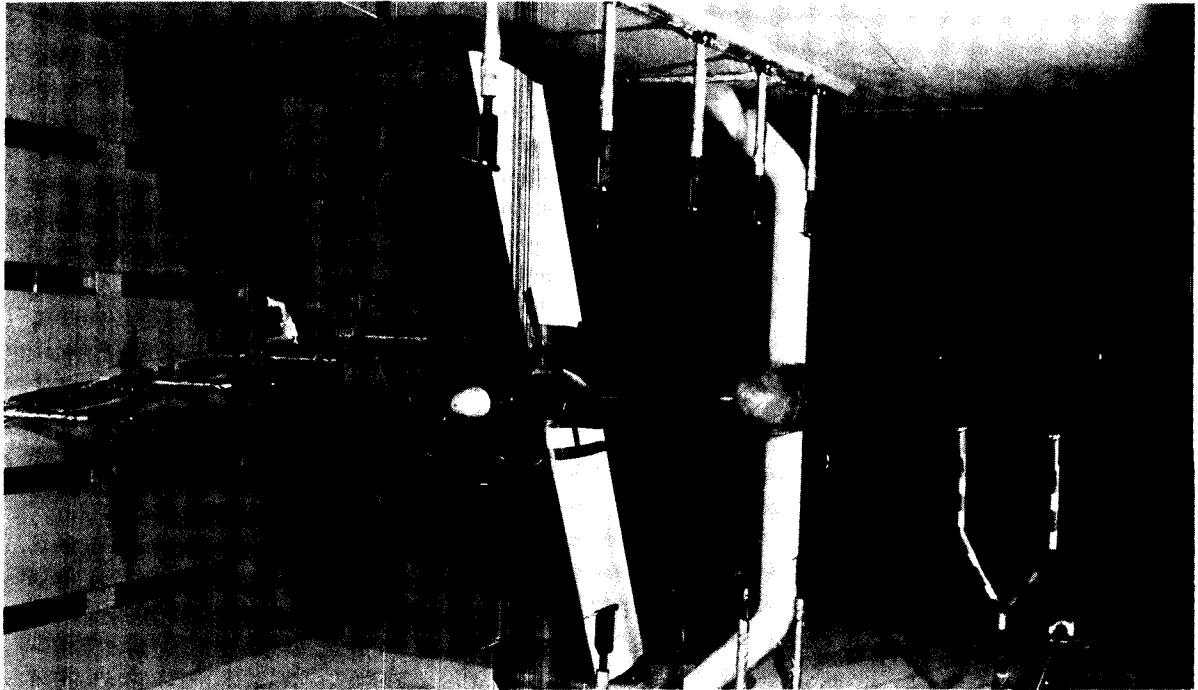

CD-87-29485

ORIGINAL PAGE IS  
OF POOR QUALITY

## EFFECT OF ANGLE OF ATTACK ON FLYOVER NOISE

Fundamental tone directivities are shown for four angles of attack ranging from 0 to 15°. The peak levels, approximately in the plane of rotation, increased by about 10 dB. A typical maximum takeoff angle of the propeller centerline with respect to the aircraft flight path is about 8°; thus takeoff noise would be increased of the order of 5 dB due to unsteady loading at that angle of attack.

### EFFECT OF ANGLE OF ATTACK ON FLYOVER NOISE

SINGLE-ROTATION PROPELLER SR-7A; 9- BY 15-ft WIND TUNNEL; TAKEOFF BLADE ANGLE, 37.8°; TIP SPEED, 800 ft/sec; TUNNEL MACH NUMBER, 0.2

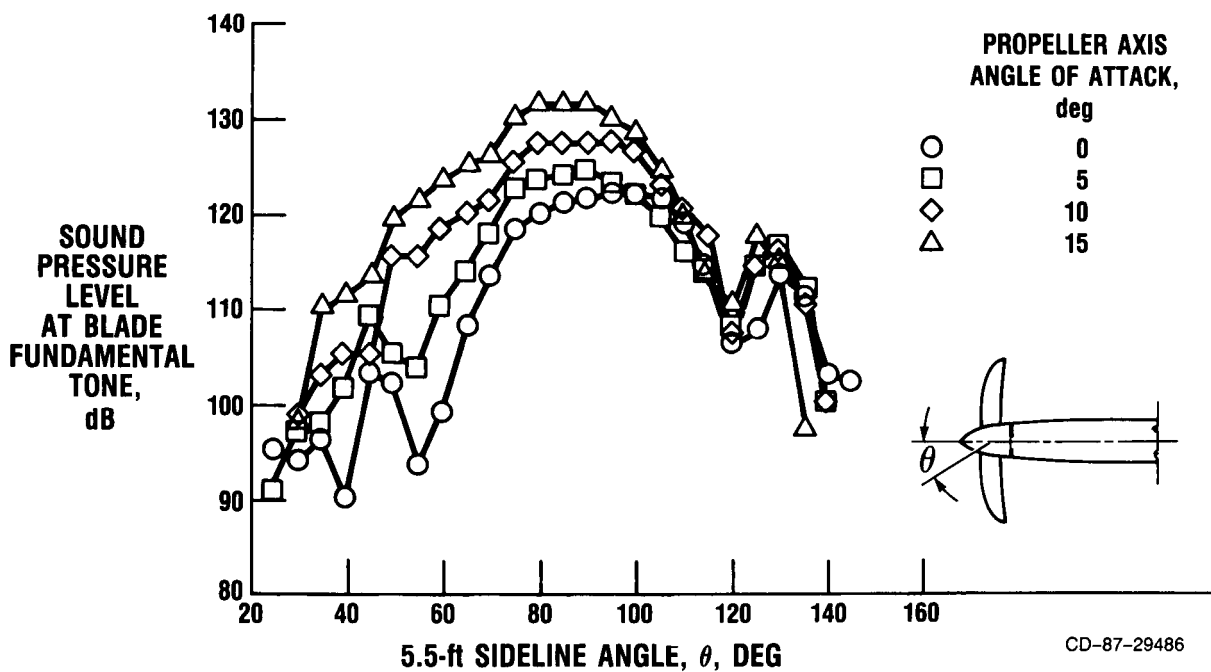

ORIGINAL PAGE IS  
OF POOR QUALITY

#### TWO-BLADE VERSION OF LARGE-SCALE ADVANCED PROPFAN (LAP)

A two-blade version of the eight-blade large-scale advanced propeller (LAP) was tested in the ONERA S1 wind tunnel to obtain steady and unsteady blade pressures over a wide range of operating conditions. Only two blades were used because of the limited total power available to drive the propeller. In this way the propeller could be operated at a reasonable power per blade. The large size of this propeller (9 ft diameter) allowed much more detailed measurements than could be obtained on the 2-ft-diameter models tested previously.

#### TWO-BLADE VERSION OF LARGE-SCALE ADVANCED PROPFAN (LAP)

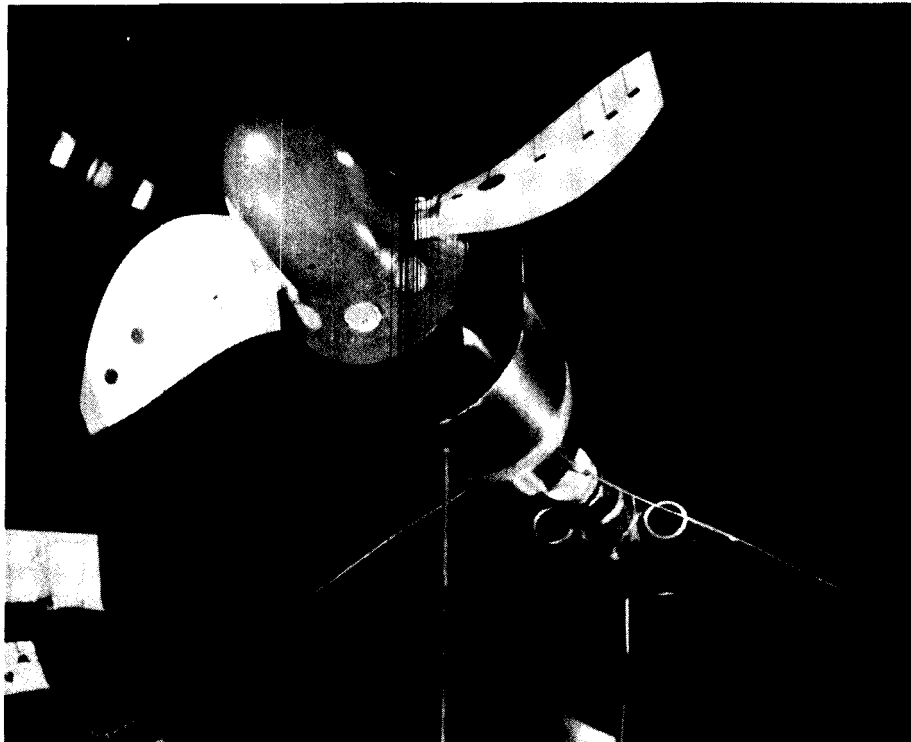

CD-87-29487

## BLADE PRESSURE MEASUREMENTS ON FULL-SCALE PROPELLER

Steady blade pressure distributions are shown at several spanwise locations on the SR-7L at a low-speed, high-power condition. The pressure distributions at the two locations nearest the tip lack the high suction peaks of the inboard locations because of the presence of the leading edge and tip vortices at the outboard locations. Similar data were obtained at 12 additional operating conditions, providing valuable data for code verifications.

## BLADE PRESSURE MEASUREMENTS ON FULL SCALE PROPELLER LOW-SPEED CONDITIONS

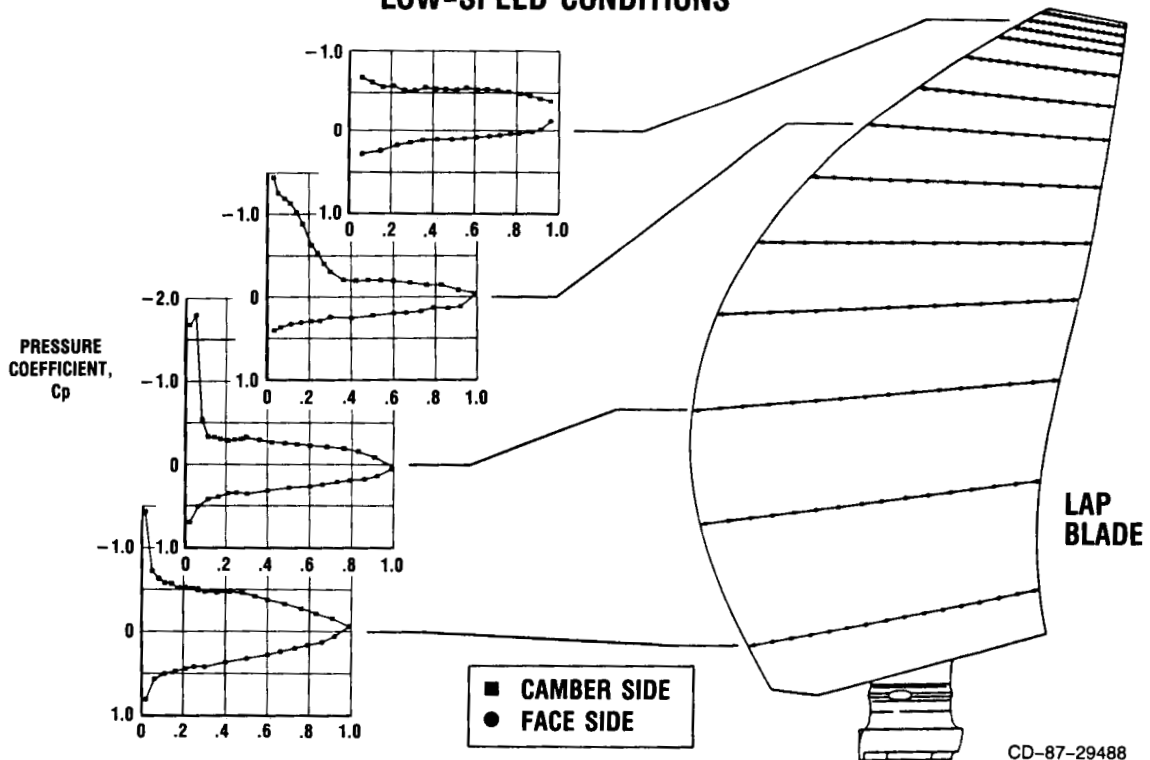

## OFF-DESIGN PROPELLER OPERATION

When the propeller is operating appreciably off-design (cruise), such as at takeoff, a leading edge vortex which merges with the tip vortex is expected to form as shown schematically. The phenomenon is similar to the vortex structure on a delta wing aircraft at high angle of attack during approach. If the associated altered loading distribution is not accounted for in analytical models, errors in aerodynamic performance and the tone noise level predictions will result as illustrated.

## OFF-DESIGN OPERATION

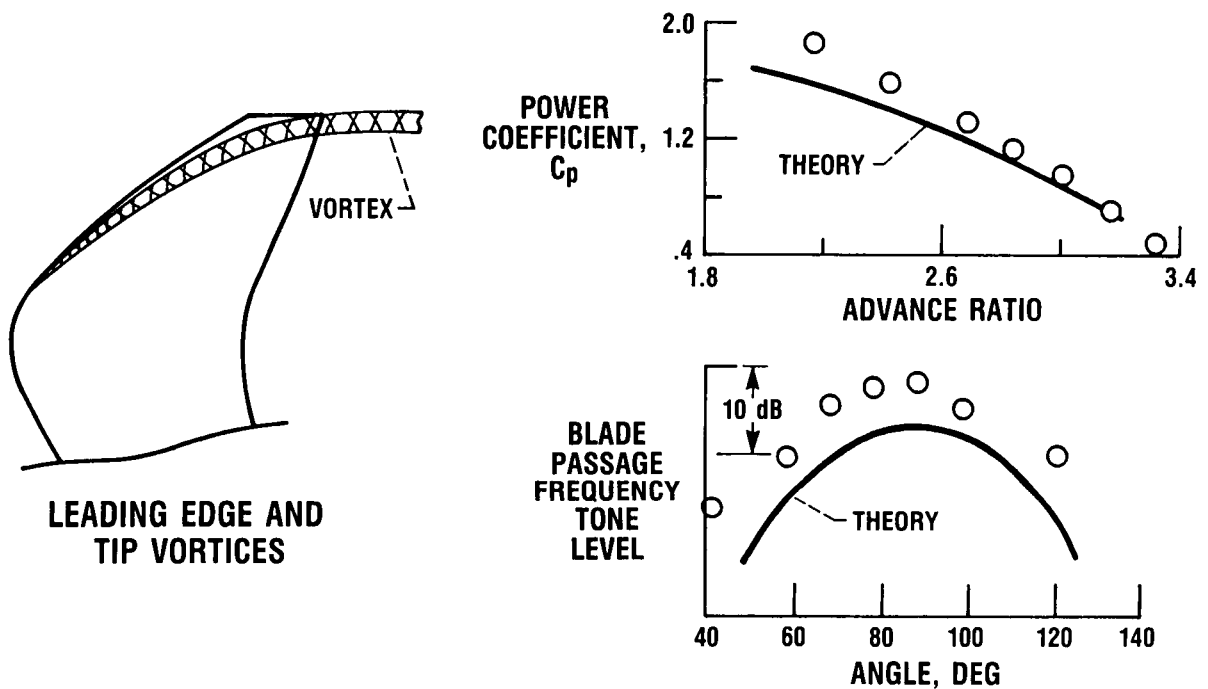

CD-87-29489

VISUALIZATION OF PROPELLER BLADE SURFACE FLOW  
AT OFF-DESIGN CONDITIONS

The fluorescent oil flow patterns on the pressure side of the SR-3 blade at the Mach 0.8, windmill condition are shown. Streaks in the oil at the blade surface are influenced by two main factors. Centrifugal forces cause radial flow in the oil film. Shear flow forces at the surface act mainly along streamlines. Over much of the blade the streaks are at an angle determined by these two forces. However, near the leading edge on the outboard portion of the blade and at the tip, the lines are primarily radial. This indicates a different flow regime, interpreted as the existence of a leading edge vortex merging with a tip vortex.

**VISUALIZATION OF PROPELLER BLADE SURFACE FLOW  
OFF-DESIGN CONDITIONS**



CD-87-29490

ORIGINAL PAGE IS  
OF POOR QUALITY

ORIGINAL PAGE IS  
OF POOR QUALITY

### COMPUTED STREAMLINES ON CRP-X1 PROPELLER

An Euler code developed at Lewis was run at United Technologies Research Center (UTRC) with an order of magnitude increase in grid points to about 200 000. When particle paths were traced they revealed the leading edge vortex which merges with the tip vortex flow. The operating condition at Mach 0.2 and advance ratio of 1.0 is typical of a takeoff situation which involves high incidence angles. Apparently, numerical "viscosity" is sufficient to trigger vortex formation and produce at least a qualitative description of this flow phenomenon.

### COMPUTED STREAMLINES ON CRP-X1 PROPELLER MACH 0.2; J = 1.0

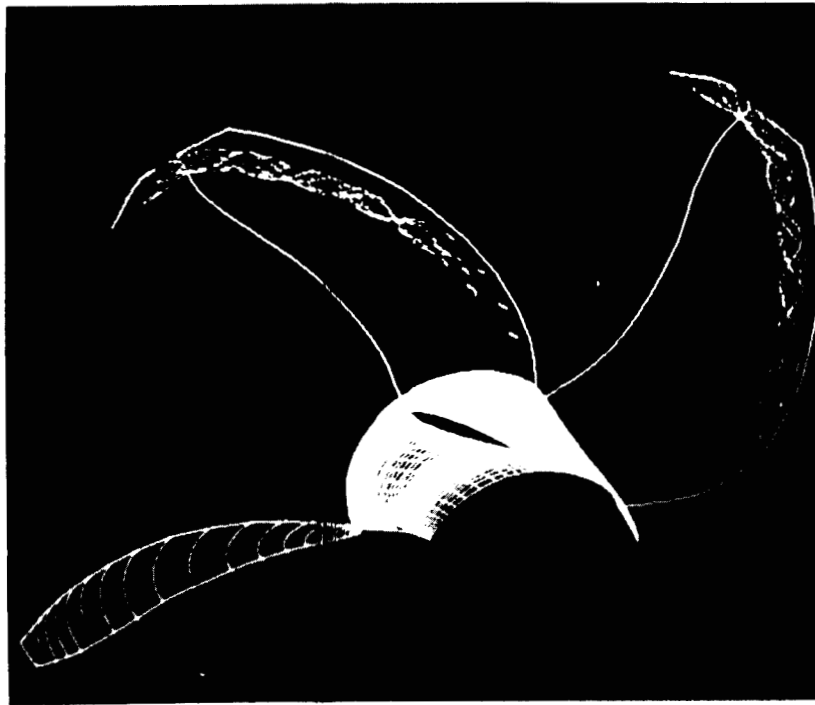

CD-87-29491

## COUNTERROTATING PROPELLER (CRP-X1) IN UTRC WIND TUNNEL

This propeller model, designated CRP-X1, was designed and built by Hamilton Standard and is shown installed in the UTRC high-speed wind tunnel. The front and rear propellers are independently driven by two air-driven turbines. Propeller performance and flow field data, as well as blade stresses were measured during these tests. Propeller acoustic data were obtained during separate tests in the UTRC Acoustic Research Tunnel.

## COUNTERROTATING PROPELLER (CRP-X1) IN UTRC WIND TUNNEL

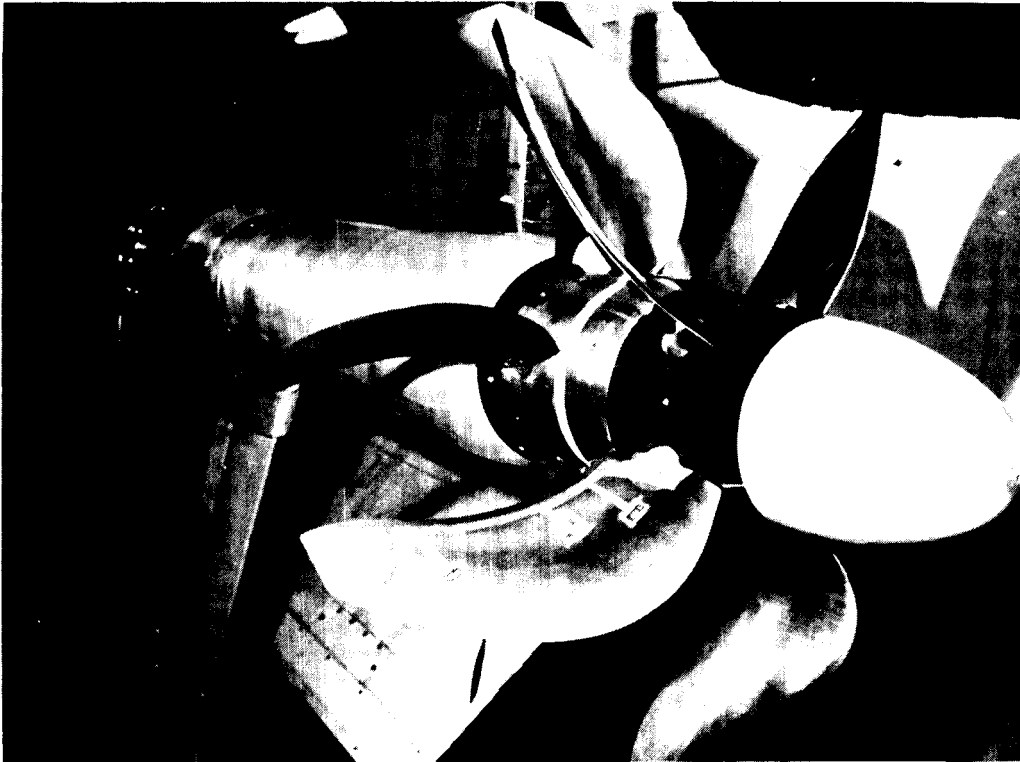

CD-87-29492

ORIGINAL PAGE IS  
OF POOR QUALITY



### CRP-X1 PERFORMANCE COMPARISON

The net efficiency of the CRP-X1 propeller model is shown as a function of power loading at three free-stream Mach numbers. At the design power loading of 37.2 shp/D<sup>2</sup>, the data indicate a net efficiency of approximately 85 percent for Mach numbers in the range of 0.7 to 0.8. The efficiency also remains high over a wide range of power loadings. The predicted efficiency agrees very well with the data at Mach 0.8, but somewhat overpredicts the efficiency at the lower Mach numbers.

### CRP-X1 PERFORMANCE COMPARISON

$\Delta\beta = 2.6^\circ$ ; tip speed, 750 ft/sec

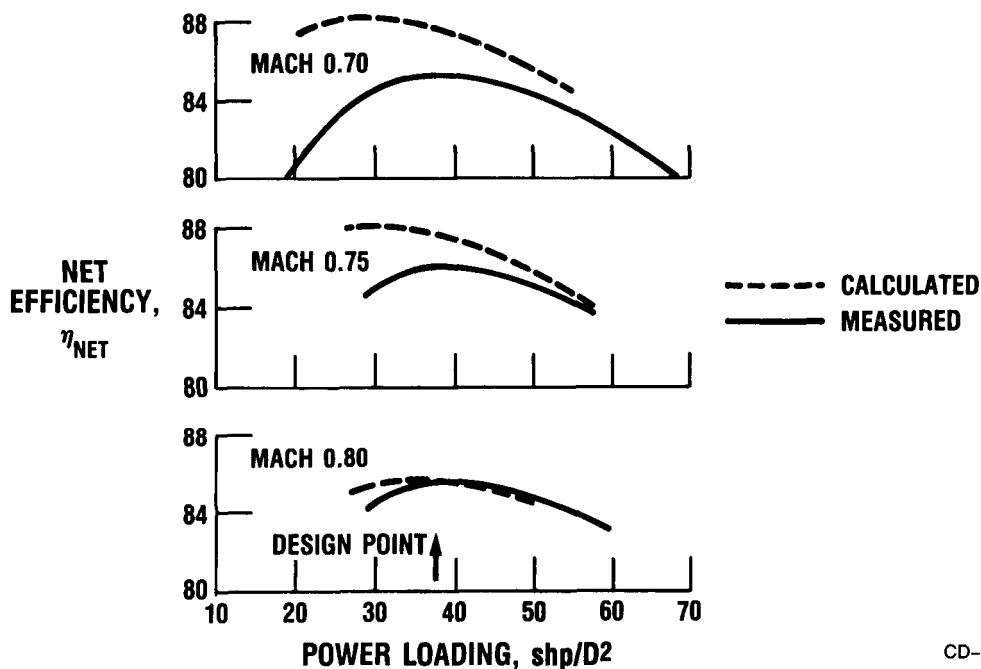

CD-87-29493

## COUNTERROTATION PROPELLER INTERACTION NOISE

Levels of the first five harmonics of single-rotation (SRP) and counterrotation (CRP) propeller noise are shown at three axial locations in the far field: forward, aft, and in the plane of rotation. The single rotation fundamental tone levels are adjusted upward three decibels to compare the equivalent of two independent propellers with the CRP-X1 counterrotation configuration. Single and counterrotation fundamental tones are then roughly equal, but the counterrotation harmonic levels are dramatically higher at all locations due to the unsteady aerodynamic interactions between blade rows. This characteristic of high fore and aft harmonic levels must be dealt with to achieve acceptable counterrotation community noise levels.

### COUNTERROTATION PROPELLER INTERACTION NOISE

CRP-X1 AT TAKEOFF CONDITIONS: ( $V_T = 650$  ft/sec; 100 shp/rotor)

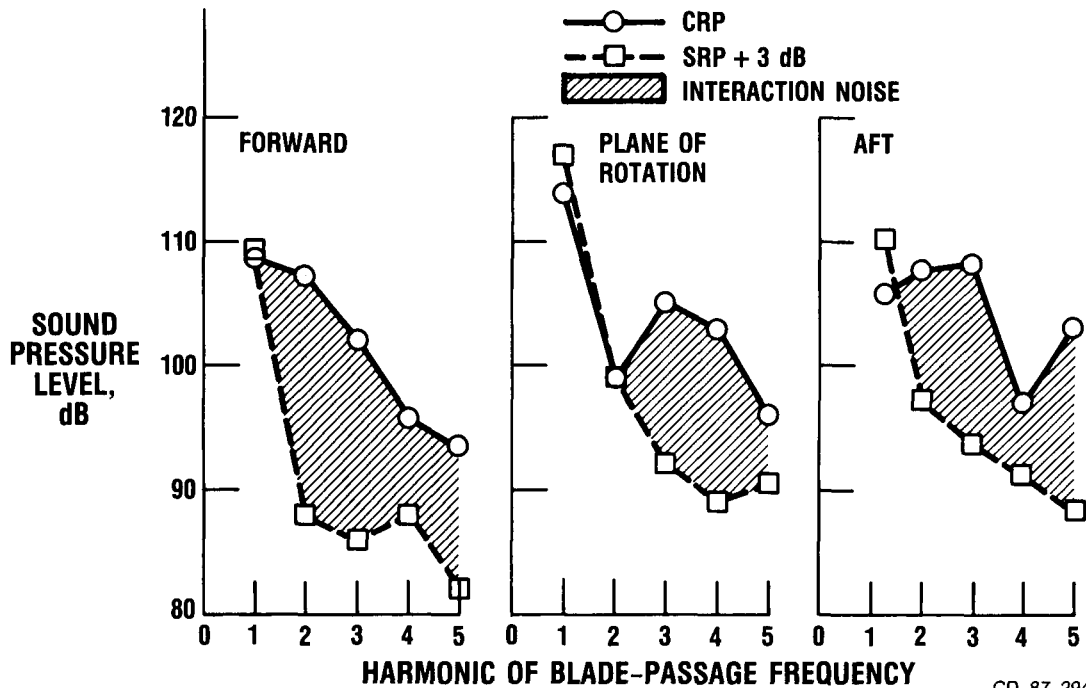

CD-87-29494

## COUNTERROTATION PROPELLER IN LEWIS 8- BY 6-FT WIND TUNNEL

The NASA Lewis counterrotation pusher propeller test rig is shown installed in the 8- by 6-foot wind tunnel. The tunnel has holes in the walls equivalent to about 6 percent porosity to minimize wall interactions at transonic speeds. The rig is strut mounted and is powered by two turbines using 450-psi drive air. Performance, flow field, and acoustic measurements are made during testing.

## COUNTERROTATION PROPELLER IN LEWIS 8- BY 6-FT WIND TUNNEL

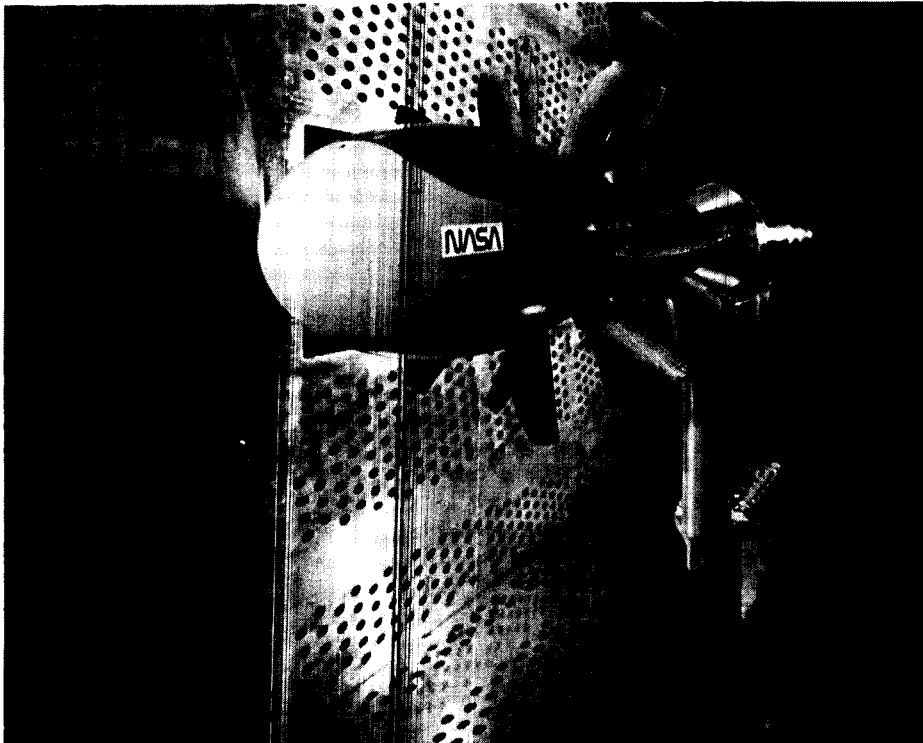

CD-87-29495

ORIGINAL PAGE IS  
OF POOR QUALITY

## MODEL COUNTERROTATION PROPELLER BLADES

The blade configurations tested included designs for Mach 0.72 cruise (top row) and Mach 0.8 cruise (bottom row). The designs differed in tip sweep, planform shape, airfoil camber, and a significantly shortened aft rotor (A3). The planform shapes for most forward and aft rotors were very similar. The aft rotor planform for A21 is included since it differs so much from the front rotor F21. Data from the Mach 0.72 configurations will be compared. The F1-A1 configuration is very similar to F7-A7 but with reduced camber, which is expected to improve cruise efficiency. F1-A3 was run to see the aerodynamic and acoustic effects of a short aft rotor. Both F1-A1 and F1-A3 were run with a 9+8 blade configuration as well as the standard 8+8. These blades were designed and built by the General Electric.

## MODEL COUNTERROTATION PROPELLER BLADES

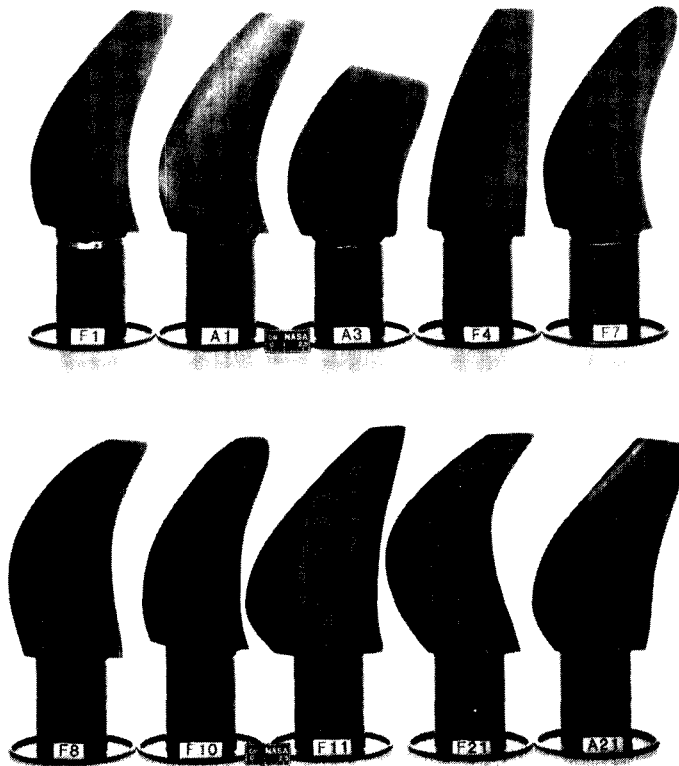

CD-87-29496

### COUNTERROTATION TONE LEVELS AT CRUISE

Fundamental tone directivities for F7-A7, the proof-of-concept UDF configuration, are compared for model data from the Lewis 8- by 6-ft wind tunnel scaled to full-scale cruise conditions, full-scale flight data obtained by the formation flight of the instrumented Lewis Learjet with the UDF engine on the 727, and predicted levels from a frequency domain model developed by at General Electric. There is excellent agreement between the model wind-tunnel measurements and full-scale flight data. Predicted levels agree quite well with the data except for the forward angles. Detailed conditions for the data shown are given below:

	Forwrd/aft blade pitch, deg	Power, percent MXCL	Source
○	58.5/57.7	100	8- by 6-ft wind tunnel
□	61.6/54	100	Lear jet
△	59/53.3	76	
◇	59.3/52.9	87	
△	59.2/52.8	77	Predicted
— —	58.7/57.7	100	

### COUNTERROTATION TONE LEVELS AT CRUISE

PROPELLER F7-A7; MACH 0.72; ALTITUDE, 35 000 ft

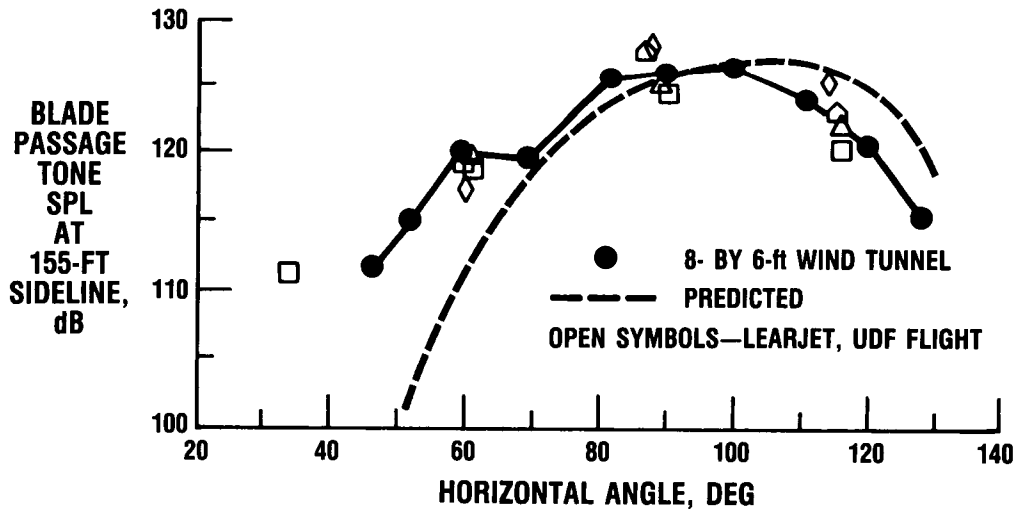

CD-87-29498

## COUNTERROTATION MODEL F7-A7 IN THE LEWIS 9- BY 15-FT ANECHOIC WIND TUNNEL

The model of the 8+8 configuration of the propeller used on the UDF proof-of-concept engine is shown in the 9- by 15-ft anechoic wind tunnel where extensive community noise tests were conducted. Unequal blade numbers, differential diameter, rotor-to-rotor spacing, angle of attack, and effects of an upstream support pylon were investigated. A continuously traversing "flyover" noise microphone can be seen at right. A circumferentially traversing microphone (not shown) was also used to map the asymmetric sound field with the model at angle of attack or with a pylon installed. The tunnel walls are acoustically treated to make the test section anechoic down to 250 Hz, well below the fundamental tone frequency of the model.

## COUNTERROTATION MODEL F7-A7 IN LEWIS 9- BY 15-FT ANECHOIC WIND TUNNEL

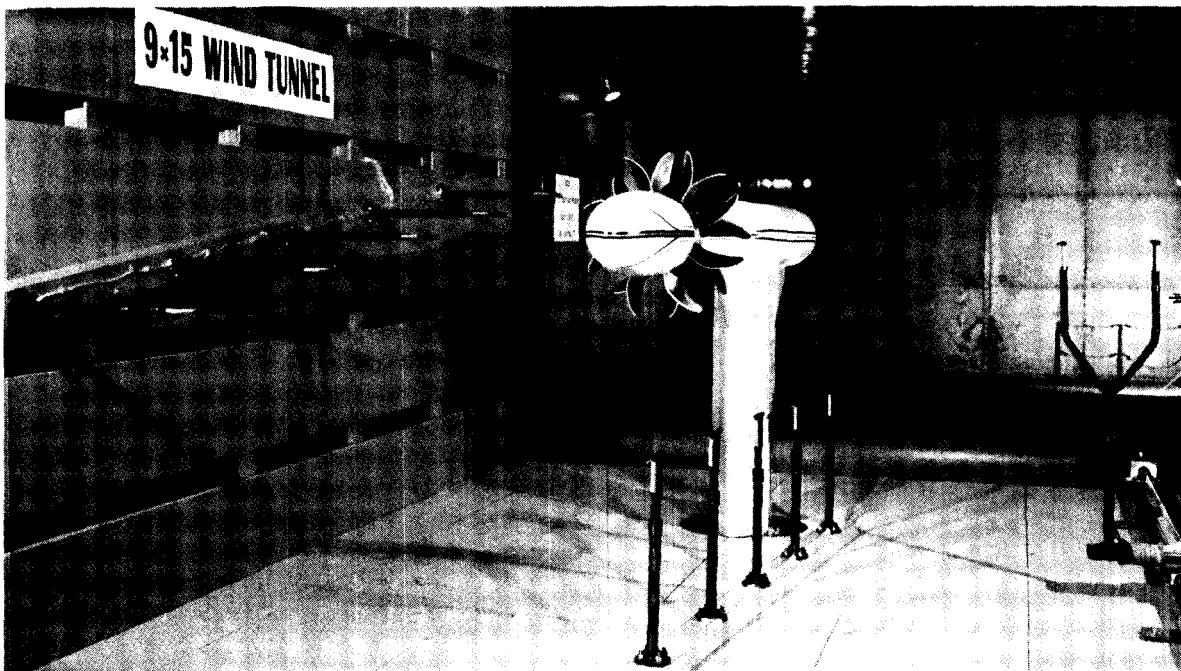

CD-87-29499

ORIGINAL PAGE IS  
OF POOR QUALITY

## COUNTERROTATION PROPELLER NOISE AT TAKEOFF

Measured and predicted directivities of the front rotor fundamental and the first interaction tone for F7-A7 at Mach 0.2 are compared. The predictions are from a frequency domain theory developed at General Electric. Note, again, the high levels of interaction tone noise at both forward and aft angles, in contrast to the forward rotor alone fundamental which peaks in the plane of rotation. Agreement between theory and data is very good for the front rotor fundamental. The predicted shape of the first interaction tone agrees well with the data, but the levels underpredict at the extremes in angle indicating more code development work is required for the interaction noise sources.

### COUNTERROTATION PROPELLER NOISE AT TAKEOFF F7-A7; MACH 0.2; 9- BY 15-ft WIND TUNNEL

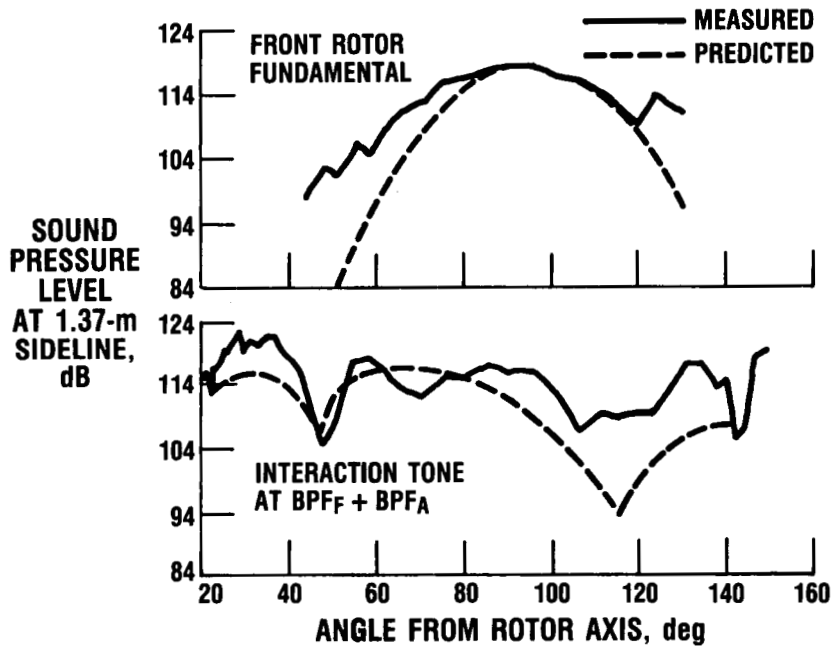

CD-87-29500

## THREE-DIMENSIONAL EULER ANALYSIS OF COUNTERROTATING PROPELLER FLOW FIELD

A counterrotation Euler code developed at NASA Lewis has been used to obtain numerical predictions of the flow about one version of the General Electric UDF. The solution is obtained by iterating between the front and rear blade rows. The coupling between rows is done in an axisymmetric sense, so there are no blade-wake interactions included. This three-dimensional image shows the pressure distribution on the nacelle and blade surfaces as well as on a plane perpendicular to the axis of rotation at the aft end of the nacelle. The pressures range from high (red) to low (blue) with the yellow-green range in the middle. The flow field pressures were taken from the flow field of the rear row and show near-field acoustic pressure perturbations spiraling out into the flow. The calculations were done at Cray Research, and the flow field was displayed using the code movie-BYU.

## THREE-DIMENSIONAL EULER ANALYSIS OF COUNTERROTATION PROPELLER FLOW FIELD

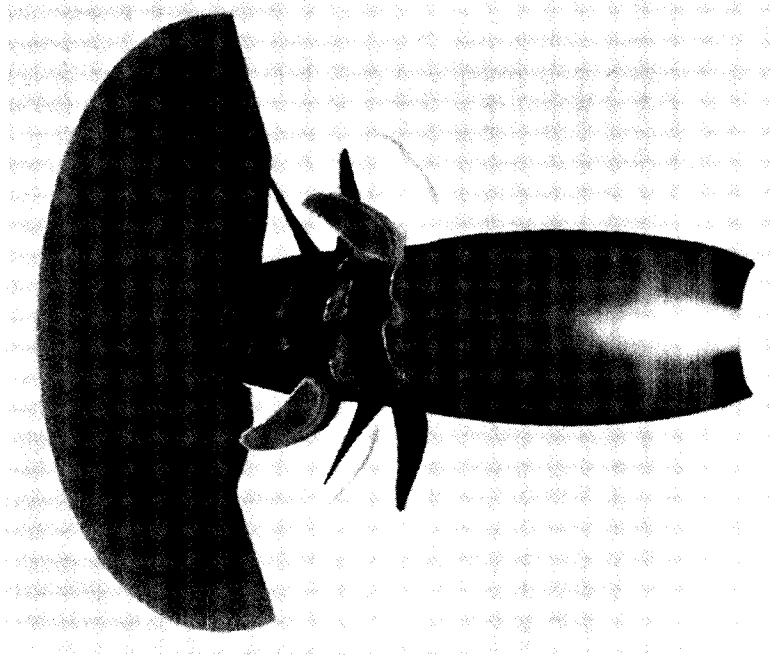

CD-87-29501

ORIGINAL PAGE IS  
OF POOR QUALITY

~~REPLACES PAGE 10  
OF REPORT~~



UNSTEADY THREE-DIMENSIONAL EULER CODE SOLUTION FOR PROPELLER  
AT ANGLE OF ATTACK

Results from an unsteady Euler code solution for the SR-3 propeller with its axis at  $4^\circ$  to the mean 0.8 Mach number flow are shown. As the propeller rotates, downward moving blades (on the right in the figure) experience the highest incidence, upward blades (on the left) the lowest, and top and bottom are near the mean. Chordwise pressure distributions are plotted on the blade surfaces. Very high loadings are indicated on the blade moving downward at about  $90^\circ$  (on the right) where the highest incidence angles are experienced. In comparison much lower loadings are experienced by the top vertical blade, which has incidence angles near the mean value. This unsteady Euler code was developed at Mississippi State University, and graphics were done at the Air Force Arnold Engineering and Development Center.

**UNSTEADY 3D EULER CODE SOLUTION FOR PROPELLER  
AT ANGLE OF ATTACK**

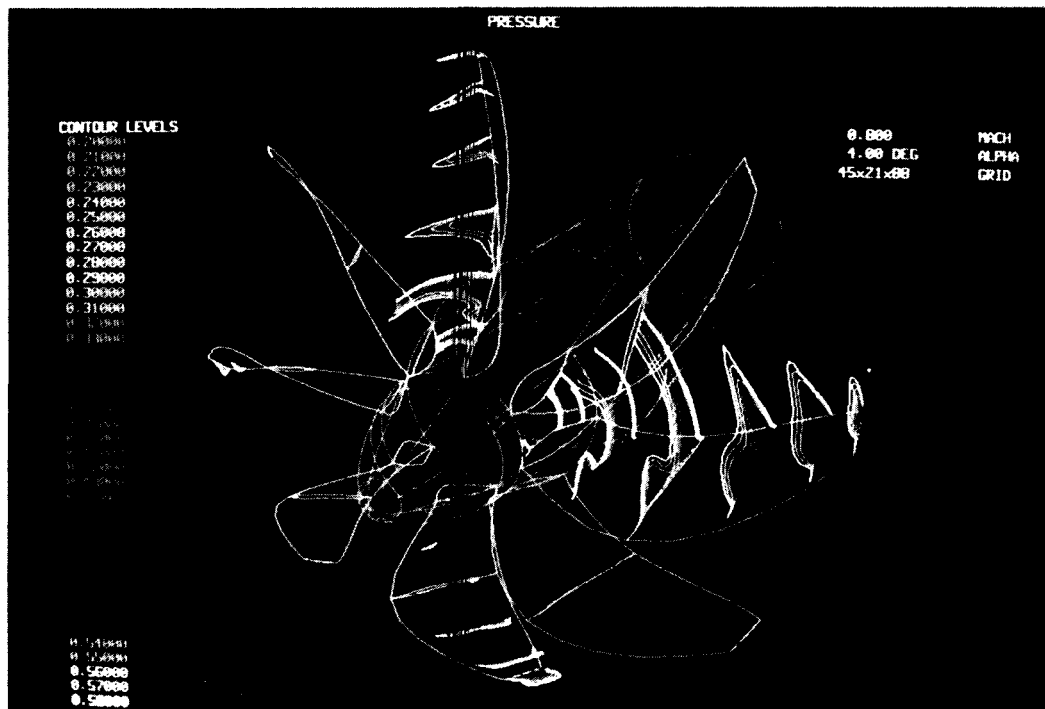

CD-87-29502

ORIGINAL PAGE IS  
OF POOR QUALITY

ORIGINAL PAGE IS  
OF POOR QUALITY

### UNSTEADY THREE-DIMENSIONAL EULER SOLUTIONS FOR COUNTERROTATION PROPELLER

The unsteady Euler solution algorithms were also applied to the 8+8-configuration F7-A7 counterrotation propeller to obtain a full unsteady three-dimensional solution for the flow field. A sample of the results in the form of pressure contours in a plane just downstream of both blade rows is shown. These contours, which are for a particular instant in time, show an island structure indicative of the tip vortices shed by the blades. Current solution methods handle equal blade numbers in each row and are being extended to treat the general case of unequal blade numbers.

### UNSTEADY 3D EULER SOLUTION FOR COUNTERROTATION PROPELLER

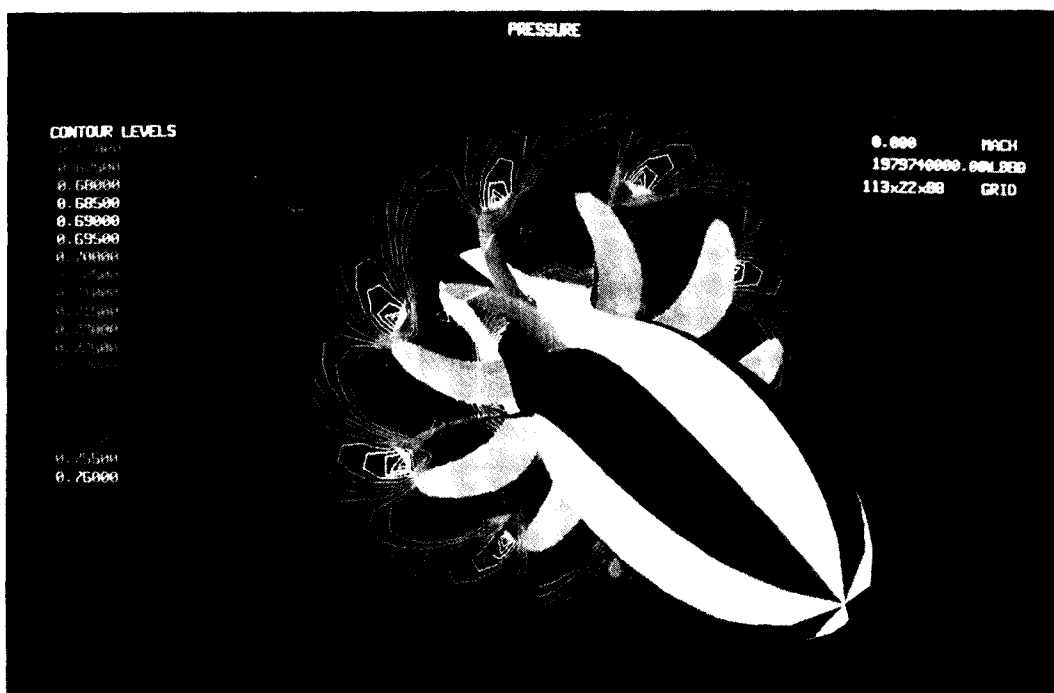

CD-87-29503

COMPARISON OF MEASURED AND CALCULATED FLUTTER BOUNDARIES

An experimental and analytical research program is being conducted to understand the flutter and forced response characteristics of advanced high-speed propellers. A comparison of measured and calculated flutter boundaries for a propfan model, called SR3C-X2, is shown in the figure. The theoretical results, from the Lewis-developed ASTROP3 analysis, include the effects of centrifugal loads and steady-state, three-dimensional air loads. The analysis does reasonably well in predicting the flutter speeds and slopes of the boundaries. However, the difference between the calculated and measured flutter Mach numbers is greater for four blades than for eight blades. This implies that the theory is overcorrecting for the decrease in the aerodynamic cascade effect with four blades.

COMPARISON OF MEASURED AND CALCULATED  
FLUTTER BOUNDARIES  
SR3C-X2 PROPFAN MODEL

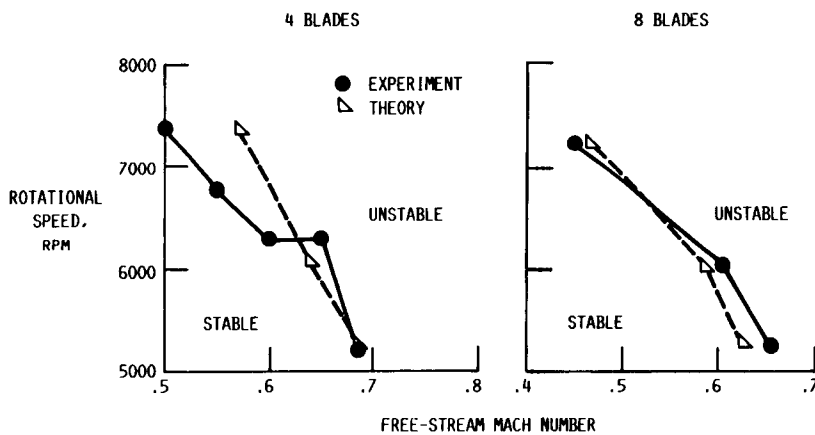

CD-87-29586

## SWEPT CASCADE EXPERIMENT

Wind tunnel tests of the SR-5 propeller demonstrated that cascade effects and sweep effects have a destabilizing influence on the flutter boundary at relative Mach numbers approximately equal to one. Experimental research conducted in the NASA Lewis transonic oscillating cascade will investigate the subsonic and transonic steady and unsteady aerodynamics relevant to advanced turboprops. An unswept cascade will provide baseline data. Following that, the aerodynamics of a cascade of airfoils with sweep will be quantified. Both subsonic and transonic flow fields will be investigated as the airfoils undergo torsional oscillations at realistic reduced-frequency values.

### SWEPT CASCADE EXPERIMENT

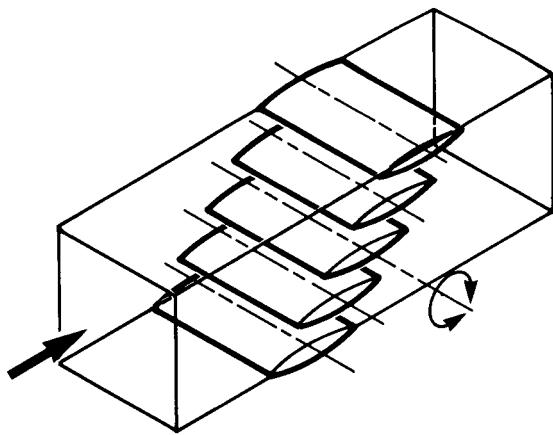

UNSWEPT CASCADE

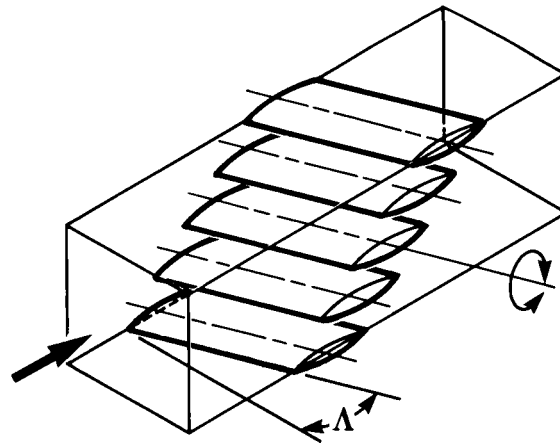

SWEPT CASCADE

- EXPERIMENT TO DETERMINE EFFECT OF BLADE SWEEP,  $\Lambda$ , ON TRANSONIC CASCADE AERODYNAMICS
- STEADY AND UNSTEADY BLADE SURFACE PRESSURES
- TORSIONAL BLADE OSCILLATION
- DATA USED TO BENCHMARK STEADY AND UNSTEADY ANALYSES

CD-87-29505

TWO-DIMENSIONAL UNSTEADY, NAVIER-STOKES  
OSCILLATING CASCADE ANALYSIS

A compressible, unsteady, full Navier-Stokes, finite-difference code has been developed for modeling transonic flow through two-dimensional, oscillating cascades. The procedure introduces a deforming grid technique to capture the motion of the airfoils. The use of a deforming grid is convenient for treatment of the outer boundary conditions since the outer boundary can be fixed in space, while the inner boundary moves with the blade motion. The code is an extension of the isolated airfoil code developed at the Georgia Institute of Technology. The motion of the shock wave is evident in the chordwise pressure distributions.

**2D UNSTEADY, NAVIER-STOKES, OSCILLATING CASCADE ANALYSIS**

**NACA 16-004 CASCADE;  $M_1 = 0.75$ ;  $g = 1.0$ ;  $\alpha_m = 21^\circ$ ;  $\alpha_1 = \pm 2.0^\circ$ ;  $k = 0.20$ ;  
 $Re = 5.0 \times 10^6$ ;  $\theta = 20^\circ$ ;  $\sigma = 90^\circ$**

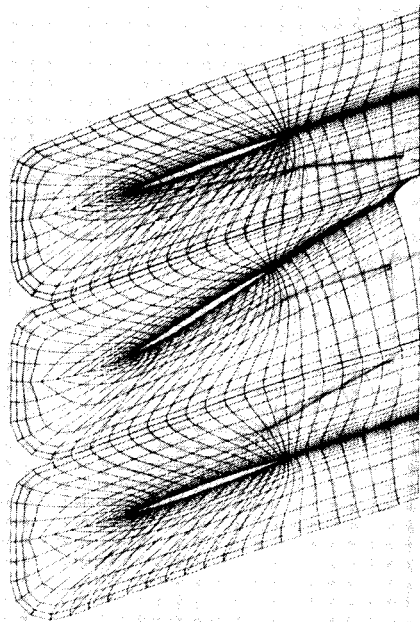

**DEFORMING GRID (EXAGGERATED MOTION)**

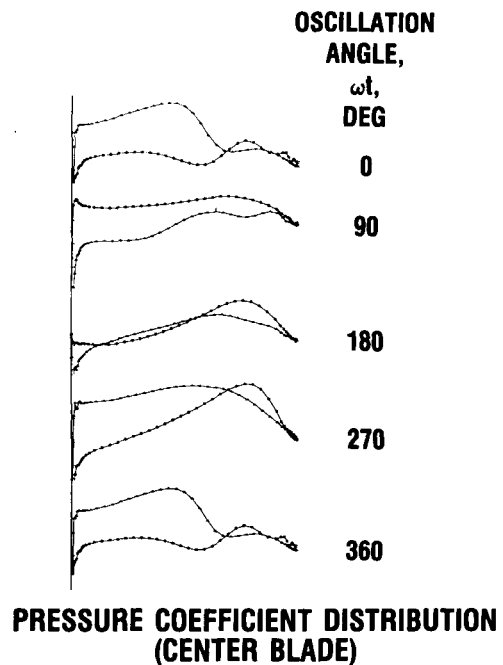

**PRESSURE COEFFICIENT DISTRIBUTION  
(CENTER BLADE)**

CD-87-29506

## SWIRL RECOVERY VANE EXPERIMENT

The Swirl Recover Vane Experiment will investigate the fuel saving and noise benefits available by adding swirl recovery vanes (SRV) behind a propfan. Thus, the 1000-hp single-rotation propeller test rig will be modified to accept a new balance and 12 swirl recovery vanes. These tests will determine the fuel saving benefits of the SRV concept over its Mach number operating range (0 to 0.85). Other parametric variations will include vane angle and vane axial spacing relative to the propfan. Also, flow visualization of the flow dynamics will be done.

### SWIRL RECOVERY VANE EXPERIMENT

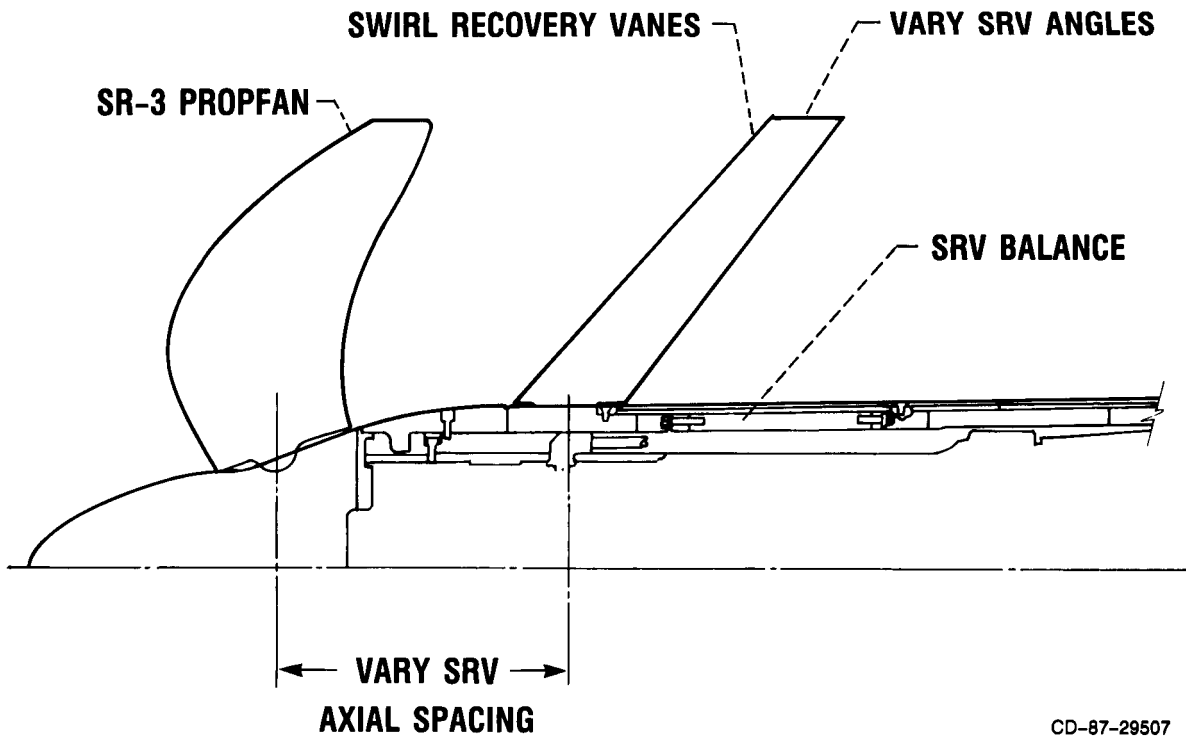

CD-87-29507

## HIGH-SPEED DUCTED PROPELLER ISSUES

Technical issues requiring research are noted for high-speed cruise in the upper half of the figure and for low-speed takeoff or approach in the lower half. At cruise, the drag of the large-diameter thin cowl must be minimized while achieving acceptable near-field sound levels. A synthesis of propeller and fan aerodynamic design methods is required to arrive at an optimum combination of sweep and of axial and tip Mach numbers. At low speed far-field community noise, cowl-lip separation at high angles of attack with the associated blade stresses and reverse thrust operation must each be addressed.

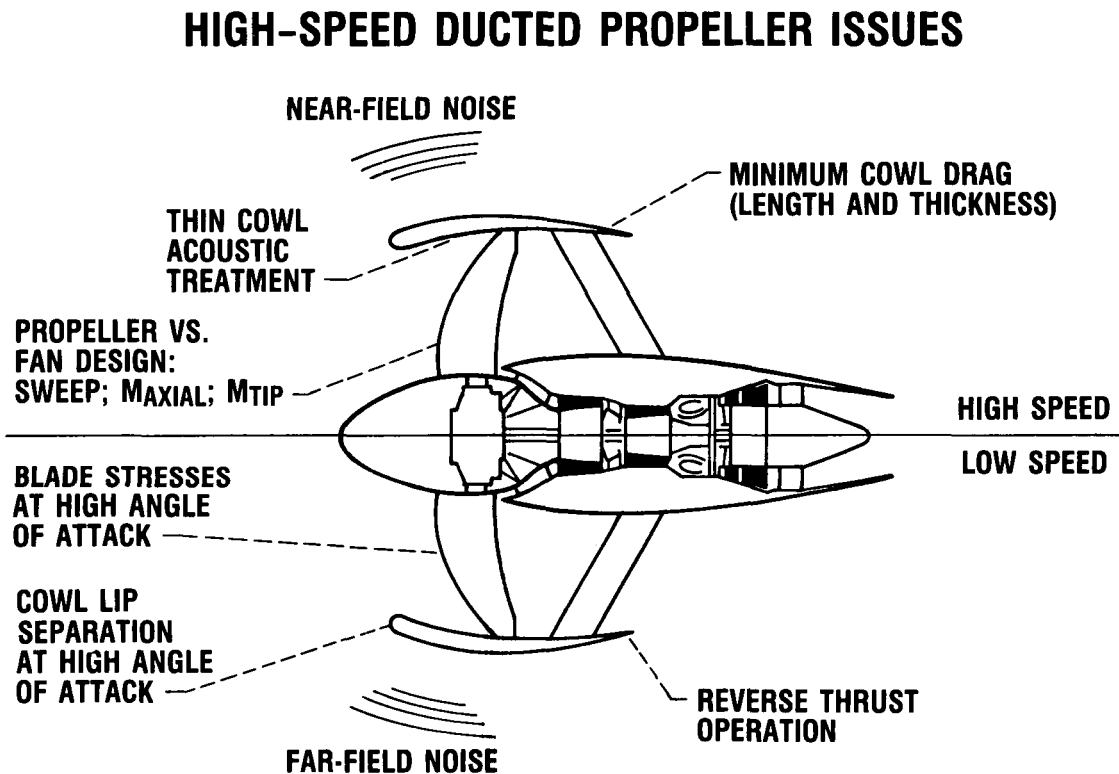

CD-87-29508

## PROPELLER RESEARCH AREAS OF EMPHASIS

The status of current and future propeller research in each of the three disciplines (aerodynamics, acoustics, and aeroelasticity) is summarized. Presently, aerodynamic work emphasizes three-dimensional steady Euler solutions and performance measurements with some diagnostics, while future work is moving toward three-dimensional unsteady Euler and Navier-Stokes codes with more emphasis on detailed flow field diagnostics. Acoustically, three-dimensional codes are used with detailed steady aerodynamic input and extensive cruise and takeoff signatures have been measured for both single and counterrotation. Future efforts will emphasize unsteady aerodynamic inputs to the codes to describe interaction and installation effects and experiments will concentrate on detailed noise maps for installed configurations. Current aeroelastics focus has been in prediction and measurement of flutter boundaries and constructing the first generation of structural design optimization codes. Future emphasis in all three disciplines will involve addressing the technical issues associated with ultra high-bypass ducted propellers.

## PROPELLER RESEARCH AREAS OF EMPHASIS

	PRESENT	FUTURE
<b>AERODYNAMICS</b>	<ul style="list-style-type: none"><li>• 3D STEADY EULER CODES</li><li>• PERFORMANCE MEASUREMENT, PROBE SURVEYS, &amp; BLADE PRESSURES</li></ul>	<ul style="list-style-type: none"><li>• 3D UNSTEADY EULER &amp; NAVIER-STOKES CODES</li><li>• DETAILED FLOW FIELD DIAGNOSTICS - LASER VELOCIMETER</li><li>• ULTRA-HIGH BYPASS DUCTED PROPELLER PERFORMANCE</li></ul>
<b>ACOUSTICS</b>	<ul style="list-style-type: none"><li>• 3D CODES USING DETAILED STEADY AERO INPUT</li><li>• CRUISE AND TAKEOFF SIGNATURES FOR SRP &amp; CRP INSTALLATIONS</li></ul>	<ul style="list-style-type: none"><li>• INTERACTION &amp; INSTALLATION EFFECTS FROM DETAILED UNSTEADY AERO INPUT</li><li>• DETAILED NOISE MAPS FOR INSTALLED CONFIGURATIONS</li><li>• CODES &amp; DATA FOR SHORT, THIN DUCTS</li></ul>
<b>AEROELASTICS</b>	<ul style="list-style-type: none"><li>• FLUTTER BOUNDARY MEASUREMENT &amp; PREDICTION FOR SRP'S</li><li>• FIRST GENERATION STRUCTURAL OPTIMIZATION CODES</li></ul>	<ul style="list-style-type: none"><li>• FLUTTER BOUNDARY MEASUREMENT &amp; PREDICTION FOR CRP'S</li><li>• STALL FLUTTER &amp; FORCED RESPONSE FOR SRP'S &amp; CRP'S</li></ul>

CD-87-29509





# Report Documentation Page

1. Report No. <b>NASA CP-10003</b>		2. Government Accession No.		3. Recipient's Catalog No.	
4. Title and Subtitle <b>Aeropropulsion '87 Session 5 - Subsonic Propulsion Technology</b>			5. Report Date <b>November 1987</b>		
			6. Performing Organization Code		
7. Author(s)			8. Performing Organization Report No. <b>E-3798</b>		
			10. Work Unit No. <b>505-62-3B</b>		
9. Performing Organization Name and Address <b>National Aeronautics and Space Administration Lewis Research Center Cleveland, Ohio 44135-3191</b>			11. Contract or Grant No.		
			13. Type of Report and Period Covered <b>Conference Publication</b>		
12. Sponsoring Agency Name and Address <b>National Aeronautics and Space Administration Washington, D.C. 20546-0001</b>			14. Sponsoring Agency Code		
			15. Supplementary Notes <b>Preprint includes figures and descriptive text.</b>		
16. Abstract <b>NASA is conducting aeropropulsion research over a broad range of Mach numbers. In addition to the high-speed propulsion research described in a separate session at this conference, major progress has been recorded in research aimed at the subsonic flight regimes of interest to many commercial and military users. This session will cover recent progress and future directions in such areas as small engine technology, rotorcraft transmissions, icing, Hot Section Technology (HOST) and the Advanced Turboprop Program (ATP).</b>					
17. Key Words (Suggested by Author(s)) <b>Aeronautical propulsion research; Materials; Structures; Internal fluid mechanics; Instrumentation; Controls; Subsonic propulsion; Supersonic propulsion; Hypersonic propulsion</b>			18. Distribution Statement <b>Unclassified - Unlimited Subject Category 07</b>		
19. Security Classif. (of this report) <b>Unclassified</b>		20. Security Classif. (of this page) <b>Unclassified</b>		21. No of pages <b>153</b>	22. Price* <b>A08</b>