

DOE/NASA/50112-73
NASA TM-100276

1N 27
1196-7
111

Hot Piston Ring/Cylinder Liner Materials—Selection and Evaluation

(NASA-TM-100276) HOT PISTON RING/CYLINDER
LINER MATERIALS: SELECTION AND EVALUATION
Final Report (NASA) 19 p CSCL 11B

N88-15872

g3/27 Unclas
0119667

Harold E. Sliney
National Aeronautics and Space Administration
Lewis Research Center

Work performed for
U.S. DEPARTMENT OF ENERGY
Conservation and Renewable Energy
Office of Vehicle and Engine R&D

Prepared for
1988 International Congress and Exposition
sponsored by the Society of Automotive Engineers, Inc.
Detroit, Michigan, February 29—March 4, 1988

DISCLAIMER

This report was prepared as an account of work sponsored by an agency of the United States Government. Neither the United States Government nor any agency thereof, nor any of their employees, makes any warranty, express or implied, or assumes any legal liability or responsibility for the accuracy, completeness, or usefulness of any information, apparatus, product, or process disclosed, or represents that its use would not infringe privately owned rights. Reference herein to any specific commercial product, process, or service by trade name, trademark, manufacturer, or otherwise, does not necessarily constitute or imply its endorsement, recommendation, or favoring by the United States Government or any agency thereof. The views and opinions of authors expressed herein do not necessarily state or reflect those of the United States Government or any agency thereof.

Printed in the United States of America

Available from

National Technical Information Service
U.S. Department of Commerce
5285 Port Royal Road
Springfield, VA 22161

NTIS price codes¹

Printed copy: A02

Microfiche copy: A01

¹Codes are used for pricing all publications. The code is determined by the number of pages in the publication. Information pertaining to the pricing codes can be found in the current issues of the following publications, which are generally available in most libraries: *Energy Research Abstracts (ERA)*; *Government Reports Announcements and Index (GRA and I)*; *Scientific and Technical Abstract Reports (STAR)*; and publication, NTIS-PR-360 available from NTIS at the above address.

Hot Piston Ring/Cylinder Liner Materials—Selection and Evaluation

Harold E. Sliney
National Aeronautics and Space Administration
Lewis Research Center
Cleveland, Ohio 44135

Work performed for
U.S. DEPARTMENT OF ENERGY
Conservation and Renewable Energy
Office of Vehicle and Engine R&D
Washington, D.C. 20545
Under Interagency Agreement DE-AI01-85CE50112

Prepared for
1988 International Congress and Exposition
sponsored by the Society of Automotive Engineers, Inc.
Detroit, Michigan, February 29—March 4, 1988

HOT PISTON RING/CYLINDER LINER MATERIALS - SELECTION AND EVALUATION

Harold E. Sliney
National Aeronautics and Space Administration
Lewis Research Center
Cleveland, Ohio 44135

SUMMARY

In current designs of the automotive (kinematic) Stirling engine, the piston rings are made of a reinforced polymer and are located near the bottom of the pistons because they cannot withstand the high temperatures in the upper cylinder region. Theoretically, efficiency could be improved if "hot piston rings" were located near the top of the pistons. This paper describes a program to select piston ring and cylinder coating materials to test this theory. Candidate materials were screened theoretically and in a pin on disk friction and wear test machine. Tests were performed in hydrogen at specimen temperatures up to 760 °C to simulate environmental conditions in the region of "hot piston ring" reversal. Based upon the results of these tests, a cobalt based alloy, Stellite 6B, was chosen for the piston rings and PS200, which consists of a metal-bonded chromium carbide matrix with dispersed solid lubricants, was chosen as the cylinder coating. Tests of a modified engine and a baseline engine showed that the hot ring did reduce specific fuel consumption by up to 7 percent for some operating conditions and averaged about 3 percent for all conditions evaluated. Related applications of high-temperature coatings for shaft seals and as back-up lubricants for gas bearings are also described.

E-3917

INTRODUCTION

There is clearly a need for high temperature, self-lubricating coatings in many areas of current technology. At NASA Lewis Research Center, the primary focus in our tribology research is to develop new, improved lubricants for current and future aerospace applications. Nevertheless, much of this research is sufficiently generic to also be applicable to many other areas including the technology of reciprocating engines.

The piston ring/cylinder wall sliding contacts in the Stirling engine and the LHR diesel (formerly, less precisely termed the adiabatic diesel) present particularly challenging high temperature lubrication problems. Wall temperatures can be as high as 600 to 1000 °C in the upper cylinder areas (refs. 1 and 2). In the automobile Stirling engine, the working gas for the thermodynamic cycle is hydrogen. The lubricant must therefore not only provide low friction and wear, but must also be chemically stable at high temperatures in the strong chemically reducing hydrogen atmosphere. At least the chemical composition of the atmosphere is constant. In the LHR diesel, on the other hand, the composition of the atmosphere in the combustion chambers is not only chemically reactive, but is also highly variable due to the complex combustion chemistry. Clearly, in-cylinder lubricants for the Stirling or the LHR diesel must possess exceptional thermochemical stability in addition to a wide temperature spectrum lubricating ability.

Some of the approaches to providing lubrication above the thermal degradation temperatures of conventional liquid lubricants are: (1) hydrodynamic gas

lubrication; (2) once through sacrificial lubrication with oil depending upon the short residence time in the contact or upon the formation of lubricative decomposition products to achieve lubrication; and (3) solid lubrication with thermochemically stable compounds capable of forming ductile, low shear strength films on the sliding surfaces. This paper describes research that we have done using the third approach.

The development of plasma sprayed coating compositions designed to have good friction and wear properties over a wide temperature spectrum are described. It was necessary to develop composite coating compositions because no single solid lubricant is known that will lubricate from a cold start condition up to the maximum operating temperatures anticipated. Criteria are given for our selection of materials. Background information is given to describe the evolution from high temperature coating compositions that lubricated over a relatively small temperature span to the recently developed PS200 series of coatings that lubricate from 25 °C or lower to 900 °C (refs. 3 to 7).

A pin on disk tribometer was used to determine the friction and wear characteristics of various sliding combinations of materials in carefully controlled atmospheres of hydrogen, helium, or air at temperatures to 900 °C. The screening results, first in helium, then in hydrogen were used to select a piston ring material and a cylinder liner coating for evaluation in a four-cylinder automobile Stirling engine test. Coatings were also evaluated as back-up lubricants for compliant (foil) air bearings for turbomachinery. Results of the screening tests and of the application tests are reviewed and summarized in this paper.

EXPERIMENTAL PROCEDURE

Friction and wear experiments were performed using the tribometer shown in figure 1. A standard pin on disk specimen configuration is used. The pins are 0.48 cm radius cylinders with a 0.48 cm radius hemispherical tip ground on one end. During sliding experiments the pin is placed in sliding contact with the experimental coating bonded to the flat surface of the rotating disk. Sliding is unidirectional at a velocity of 2.7 m/s, normal load is 5 N. The pin generates a wear track of 0.05 m diameter on the disk. The controlled atmospheres are dry hydrogen, dry helium, or air with a relative humidity at 25 °C of 50 percent. Specimens are induction heated, and temperature is measured with an infrared pyrometer at a spot of about 1.0 mm diameter on the wear track.

The test duration is 1 hr at each of three temperatures, 25, 350, and 760 °C. Rider wear is measured every 20 min by removing the pin and measuring the wear scar diameter on the hemispherical surface from which the wear volume can be calculated. Locating dowels allow accurate relocation of the pin.

Disk wear is measured after each hour by recording a surface profile of the wear track, computing the area of removed/displaced coating, and multiplying by the circumference of the wear track to obtain the wear volume.

Wear Factor k

Wear is expressed in this paper as a wear factor which relates volumetric wear to sliding distance (or sliding duration at a given sliding velocity) and

to load. Use of this factor assumes that wear volume is directly proportional to the product of the sliding distance and the load. Although this assumption is an oversimplification, it has been found to be a reasonable one for steady-state wear after the initial run in stage of wear is completed. Comparison of wear factors then allows one to estimate the relative wear resistance of various sliding combinations. The wear factor equation and units are:

$$\text{Wear factor } k = \frac{\text{volumetric wear (mm}^3\text{)}}{\text{load (N) x sliding distance (m)}}$$

The wear factor units are therefore:

$$k = \frac{\text{mm}^3}{\text{Nm}}$$

Wear factors for dry sliding typically vary from 10^{-3} to 10^{-7} mm^3/Nm with 10^{-3} indicating unacceptably high wear for any application (usually accompanied by galling with severe surface damage, and 10^{-6} or lower indicating the wear rates needed for long life sliding components. Intermediate rates may or may not be acceptable depending upon the requirement of the specific application.

MATERIALS

Pin and Substrate (Disk) Materials

Pin materials were chosen that were considered to be logical candidate piston ring materials for use in helium or hydrogen in the Stirling engine. They are two ferrous alloys, Nitronic-60 and XF818; a precipitation hardenable nickel base superalloy, Inconel X-750; and a hardenable cobalt alloy, Stellite 6B. Inconel X-750 pins were also chosen for tests in air because this alloy is used in compliant, high-temperature gas bearings. All alloy nominal compositions are given in table I.

The coatings tested in helium and hydrogen were applied to disks of XF818, which is an alloy used for the Stirling engine cast cylinder block. The coatings tested in air to 900 °C were applied to Inconel X-750 because of its superior oxidation resistance.

Coating Material Selection Criteria

Some material selection criteria are summarized in table II. The first criterion is that of survivability in the chemical and thermal environment. Thermochemical calculations are useful for estimating chemical reactivity.

When thermochemical calculations are used, their limitations must be kept in mind. One limitation is that these calculations give no quantitative indication of chemical kinetics. Also, under some nonequilibrium conditions, as when a gaseous reaction product is continuously removed from the reaction site, even reactions with small chemical reaction potential may occur at an

appreciable rate, especially at high temperatures. Nevertheless, thermochemical calculations can be very helpful in the selection of materials when these limitations are kept in mind.

Important physical properties criteria for solid lubricants involve the hardness and ductility or plasticity of the candidate material. Properties that effective solid lubricants have in common are: (1) they are soft; (2) they have a high degree of plasticity (the plasticity must be associated with a low yield strength in shear for lubricity); and (3) they must exhibit adequate adhesion to the lubricated surfaces. (Obviously, no matter how desirable the other properties of a solid are, that material cannot lubricate if it is not retained at the sliding interface).

We have used calcium fluoride, barium fluoride, and silver as solid lubricants in our high temperature coatings. They satisfy all of the above criteria over specific ranges of temperature. Thermochemical calculations indicate that these materials should be chemically stable to high temperatures in air or in hydrogen and this has been experimentally verified. The hardness-temperature characteristics of these two fluorides and of metallic silver are given in figure 2(a) from reference 8. Silver is very soft at room temperature with a hardness of about 30 kg/mm² and this continuously decreases to about 4 kg/mm² at 800 °C. Thin films of silver lubricate quite well at temperatures up to about 500 °C, but appear to have inadequate film strength to support a load at higher temperatures. The fluorides, on the other hand, are considerably harder than silver at the lower temperatures, but their hardness drops off rapidly with temperature and at about 400 °C, their hardnesses are 30 kg/mm² or less. Also, brittle to ductile transition temperatures, at high strain rates, of 300 to 400 °C have been reported for these fluorides (refs. 9 to 11). Fluoride coatings have been shown to be lubricious above 400 °C, but ineffective as lubricants at lower temperatures (ref. 4). Therefore, there is an apparent correlation of hardness-temperature characteristics and of the brittle to ductile transition temperature with the friction temperature characteristics.

Since silver films are lubricative at the lower temperatures and the fluorides discussed are lubricative at higher temperatures than silver, it is reasonable that a composite coating containing silver and the fluorides might be lubricious over a wide temperature range, and this has been demonstrated repeatedly in our research (refs. 4 and 5). Figure 2(b) from reference 4 illustrates this point. The friction-temperature characteristics of 0.02 mm thick fused fluoride coatings with and without silver, which were prepared by a process similar to porcelain enameling, are compared. The all-fluoride coatings were lubricious only above about 400 °C while the coatings that also contained silver lubricated from room temperature to 900 °C. These results with relatively thin coatings led to research with plasma sprayed coatings.

Plasma Sprayed Coatings

Background. - We have reported two series of plasma sprayed coatings containing fluoride solid lubricants: the PS100 and the PS200 series (refs. 5 and 6). The first series contains stable fluorides and silver with a nichrome binder; the second series contains the same lubricants and chromium carbide with a nickel-cobalt alloy binder. The proportions of the components can be varied to optimize the coatings for various uses. In general, the PS100 series, which is softer, has been useful in applications where a slightly

compliant, but nongalling coating is needed. An example of this type of application is the shaft seal shown in figure 3 from reference 12. Wear coefficients, k , for the PS100 series of coatings are on the order of 10^{-5} mm³/Nm and the friction coefficient is typically 0.2.

When more wear-resistant coatings are needed, the PS200 series is preferable. The PS200 concept is summarized in figure 4. As the sketch indicates, the coating is a composite material with the lubricating solids distributed throughout a very wear-resistant chromium carbide/nickel alloy matrix. The solid lubricant content can be optimized for a particular set of operating conditions. A typical composition consists of 10 wt % each of silver and calcium fluoride/barium fluoride eutectic in the metal-bonded chromium carbide matrix. Results of friction and wear tests applications of this coating are given below.

EXPERIMENTAL RESULTS-FRICTION AND WEAR

Pin on disk friction and wear experiments were conducted to select a suitable piston ring material for sliding contact with PS200 in a Stirling engine cylinder atmosphere (ref. 7). Initial screening was in helium, and the best material from this screening was then tested in hydrogen.

Friction coefficients in helium for the pin materials listed in table I sliding on PS200 are summarized in figure 5. Friction coefficients for Inconel X-750 against uncoated XF818 and for Stellite 6B against a metal bonded chromium carbide coating with no added solid lubricants are included to provide a baseline for comparison. The lowest friction coefficients were 0.25 to 0.38 for 6B pins sliding on PS200. Pin and coating wear were also the lowest for this sliding combination. In fact, no measurable coating wear occurred and wear factors, k , for the pins were on the order of 10^{-6} mm³/Nm.

The 6B/PS200 combination was then tested in hydrogen. Friction data in helium and in hydrogen are compared in figure 6. The results in hydrogen were even better than those obtained in helium. In hydrogen, the friction coefficients were 0.18 to 0.25. Coating wear was again negligible, and pin wear factors were all in the 10^{-7} to 10^{-6} mm³/Nm range. Based upon these screening experiments, Stellite 6B was the clear choice for the piston ring material.

APPLICATION TESTS OF PS200

Stirling Engine Cylinder Liner

PS200 was evaluated as a cylinder liner coating for an automobile Stirling engine. This was part of the DOE/NASA Automotive Stirling Engine Project. The lubrication of the piston ring/cylinder contacts in the Stirling engine is a challenging high-temperature tribological problem. Metal temperatures are as high as 600 to 1000 °C near the top of the cylinder walls. The working fluid in the engine thermodynamic cycle is hydrogen. The lubricant coating therefore, must not only provide low friction and wear, but also must be thermochemically stable in a strongly reducing hydrogen atmosphere.

In current designs of the Stirling engine, the piston rings are made of reinforced polytetrafluoroethylene (PTFE). They are located in ring grooves

near the bottom of the piston where the temperatures are relatively low and do not degrade the PTFE. This arrangement results in a long annular gap from the top of the piston to the piston ring. This gap is known as the "appendix gap" and it is the source of parasitic energy losses (ref. 13). It therefore would be desirable to minimize the appendix gap by locating the top ring in a groove near the top of the piston. A schematic of the ring locations in the baseline piston and in a piston with an added hot ring are shown in figure 7.

A Mechanical Technology Inc. (MTI) designed upgraded MOD I automotive Stirling engine (figure 8) was used in an engine test reported in reference 14. The cylinders were bored out to allow for a PS200 coating thickness of 0.25 mm (0.010 in.) and the pistons were modified to accept the hot piston rings. The coatings were sprayed on the cylinder walls to a thickness of about 0.35 mm (0.015 in.), then diamond ground to a final thickness of 0.25 mm. Each cylinder is part of a heater head quadrant consisting of the cylinder, a heat exchanger, and a regenerator-cooler. One quadrant of the four cylinder engine, along with a hot piston ring set and a disassembled piston are shown in figure 9. Engine tests were run at 700 °C heater head temperature and 5, 10, and 15 MPa mean operating pressures over a range of operating speeds. Tests were run both with the "hot rings" in place and without them to provide a baseline for comparison. Although budget and schedule restrictions severely limited the testing, the minimum data to assess the potential of both the "hot rings" and high temperature lubricant coating were obtained.

At some operating conditions, efficiency as indicated by specific fuel consumption increased up to 7 percent compared to the baseline engine. Under other conditions, no significant differences in efficiency were measured. The overall average indicated about a 3 percent increase in efficiency with the "hot rings" over the baseline configuration. This increase was over and above the friction loss introduced by the "hot rings." Seal leakage measurements, figure 10, showed a significant reduction in leakage with the "hot ring" in place. In addition, cylinder wall temperature measurements, figure 11, indicated less cylinder heating in the appendix gap area - between the lower piston rings and the "hot ring." Approximately 22 hr of ring-on-coating operating were recorded. After the initial break-in period, ring and coating wear were low. Figure 12 is a photograph of the coated cylinder wall after the engine test. The dark, polished surface is the area swept by the piston ring.

Both the "hot ring" concept and the PS200 coating show promise and should be pursued further. Potential benefits are applicable not only to the Stirling engine, but possibly to the adiabatic diesel as well. Figure 13 schematically illustrates how the "Hot Piston Ring" Stirling Engine Project moved forward from the selection of materials based upon their physical and chemical properties, through laboratory research which involved coating formulation and tribo-testing with a pin-on-disk bench test apparatus, and finally to an engine test. The pin-on-disk tests verified the materials selection criteria used, and also correlated with piston ring and coating performance in the engines.

Gas Bearings

Figure 14 is a gas bearing journal coated with PS200 and finished by diamond grinding. Start-stop tests of this journal in a foil bearing were conducted using the test apparatus shown in figure 15 and reported in references 15 to 17. The surface velocity and torque profiles during a typical start-stop

cycle are in figure 16. The higher torque at the beginning and end of each cycle occurs during sliding contact when the surface velocity is below the critical lift-off velocity for the bearing. Foil bearings with PS200 coated journals have routinely survived life tests consisting of 10 000 starts and stops (20 000 rubs) at preprogrammed bearing temperatures from 25 to 650 °C.

CONCLUDING REMARKS

A research program was conducted to develop self-lubricating coatings with the very wide temperature capabilities required for use as a cylinder liner coating and for other high temperature applications. The most significant observations from this program are the following:

1. Certain materials properties can be used to establish a qualitative model for predicting whether or not a chemical element or compound is likely to have solid lubrication capability within a given temperature range. The required properties are plasticity, low yield strength in shear, low hardness, and thermochemical stability at the temperatures and in the environment of interest.

2. For solid materials that lubricate only at elevated temperatures, the onset of lubrication appears to correlate with their brittle to ductile transition temperatures.

3. Some combinations of two or more solid lubricants, each with different temperature capabilities, can be incorporated into composites with a broader temperature capability than that of any single solid lubricant. An example of this is the PS200 coating discussed in this paper.

4. PS200 is a plasma sprayed composite coating in which silver and barium fluoride/calcium fluoride eutectic are dispersed throughout a matrix of metal-bonded chromium carbide. Silver alone is lubricative to about 500 °C, while the fluorides are lubricative from 400 to 900 °C. The combination in this coating lubricate from room temperature to 900 °C.

5. PS200 was formulated using the material selection model described in the paper; the basic friction and wear properties determined in pin-on-disk bench tests confirmed the validity of the model; and finally, the coating was successfully tested as a back-up lubricant coating for gas bearings to 650 °C, and as a cylinder liner material for the automotive Stirling engine to 700 °C.

REFERENCES

1. R.H. Titran and J.R. Stephens, "Advanced High Temperature Materials for the Energy Efficient Automotive Stirling Engine." NASA TM-83659, 1984.
2. R. Kamo and W. Bryzik, "Cummins/TACOM Advanced Adiabatic Engine." Proceedings of the Twenty-First Automotive Technical Development Contractors' Coordination Meeting, SAE P-138, SAE, 1984, pp. 121-134.

3. H.E. Sliney, "Plasma-Sprayed Metal-Glass and Metal-Glass-Fluoride Coatings for Lubrication to 900 °C." ASLE Transactions, Vol. 17, No. 3, July 1974, pp. 182-189.
4. H.E. Sliney, "The Use of Silver in Self-Lubricating Coatings for Extreme Temperatures." ASLE Transactions, Vol. 29, No. 3, July 1986, pp. 370-376.
5. H.E. Sliney, "Wide Temperature Spectrum Self-Lubricating Coatings Prepared by Plasma Sprayed." Thin Solid Films, Vol. 64, 1979, pp. 211-217.
6. C. Della Corte and H.E. Sliney, "Composition Optimization of Self-Lubricating, Chromium Carbide-Based Composite Coatings for Use to 760 °C." ASLE Transactions, Vol. 30, No. 1, Jan. 1987, pp. 77-83.
7. H.E. Sliney, "A New Chromium Carbide-Based Tribological Coating for Use to 900 °C with Particular References to the Stirling Engine." Journal of Vacuum Science and Technology A, Vol. 4, No. 6, Nov.-Dec. 1986, pp. 2629-2632.
8. D.L. Deadmore and H.E. Sliney, "Hardness of CaF₂ and BaF₂ Solid Lubricants at 25° to 670 °C." NASA TM-88979, 1987.
9. W.L. Phillips Jr., "Deformation and Fracture Processes in Calcium Fluoride Single Crystals." Journal of the American Ceramic Society, Vol. 44, No. 10, Oct. 1961, pp. 499-506.
10. R. Burn and G.T. Murray, "Plasticity and Dislocation Etch Pits in CaF₂." Journal of the American Ceramic Society, Vol. 45, No. 5, Nov. 1962, pp. 251-252.
11. T.S. Liu and C.H. Li, "Plasticity of Barium Fluoride Single Crystals." Journal of Applied Physics, Vol. 35, No. 11, Nov. 1964, pp. 3325-3330.
12. H.E. Sliney, "Status and New Directions for Solid Lubricant Coatings and Composite Materials." Tribology in the 80's, NASA CP-2300, Vol. 2, 1984, pp. 665-680.
13. W.A. Tomazic, "Stirling Engine Supporting Research and Technology." NASA TM-87175, 1985.
14. D.J. Allen and W.A. Tomazic, "Hot Piston Ring Tests." Proceedings of the 25th Automotive Technology Development Contractors' Coordination Meeting, Dearborn, MI, Oct. 26-29, 1987. To be published by SAE, Warrendale, PA.
15. R.C. Wagner and H.E. Sliney, "Effects of Silver and Group II Fluoride Solid Lubricant Additions to Plasma-Sprayed Chromium Carbide Coatings for Foil Gas Bearings to 650 °C." Lubrication Engineering, Vol. 42, No. 10, Oct. 1986, pp. 594-600.
16. C. Della Corte, "Composition Optimization of Chromium Carbide Based Solid Lubricant Coatings for Foil Gas Bearings at Temperatures to 650 °C." NASA CR-179649, 1987.

TABLE I. - NOMINAL COMPOSITION AND ROCKWELL HARDNESS OF CANDIDATE PISTON RINGS MATERIALS

[Compositions are taken from manufacturers' data; hardness values, at room temperature.]

| Pin material | Element wt % | | | | | | | | | | | | | | Rockwell hardness |
|---------------|--------------|----|----|-----|------|----|------|-----|------|------|-----|---|------|-----|-------------------|
| | Ni | Cr | Co | C | Fe | Al | Si | Ti | Mo | Mn | B | W | N | Cb | |
| Inconel X-750 | 70 | 16 | 1 | 0.1 | 7.5 | 1 | ---- | 2.5 | ---- | 1 | --- | - | ---- | --- | R _C 40 |
| XF818 | 18 | 18 | -- | .2 | 54.6 | - | 0.3 | --- | 7.5 | .15 | 0.7 | - | 0.12 | 0.4 | R _C 18 |
| Stellite 6B | 2 | 30 | 59 | 1 | 1 | - | .75 | --- | .75 | 1.25 | --- | 4 | ---- | --- | R _C 42 |
| Nitronic 60 | 8 | 18 | -- | .1 | 61.8 | - | 4.0 | --- | ---- | .8 | --- | - | .12 | --- | R _C 28 |

TABLE II. - SELECTION CRITERIA FOR COMPOSITE LUBRICANT COATINGS

All components: Must be survivors

- Thermochemical stability in the chemical environment at all temperature of interest.
- Compatible thermal expansion properties.
- Adhesion to the substrate.

Solid lubricants: High degree of plasticity

- Capable of extensive plastic deformation at low shear stresses.
- Soft: Hv typically 10 to 50 kg/mm² at operating temperatures.

Wear control component: Hard, wear-resistant, stable chemically and structurally.

~~ORIGINAL PAGE
COLOR PHOTOGRAPH~~

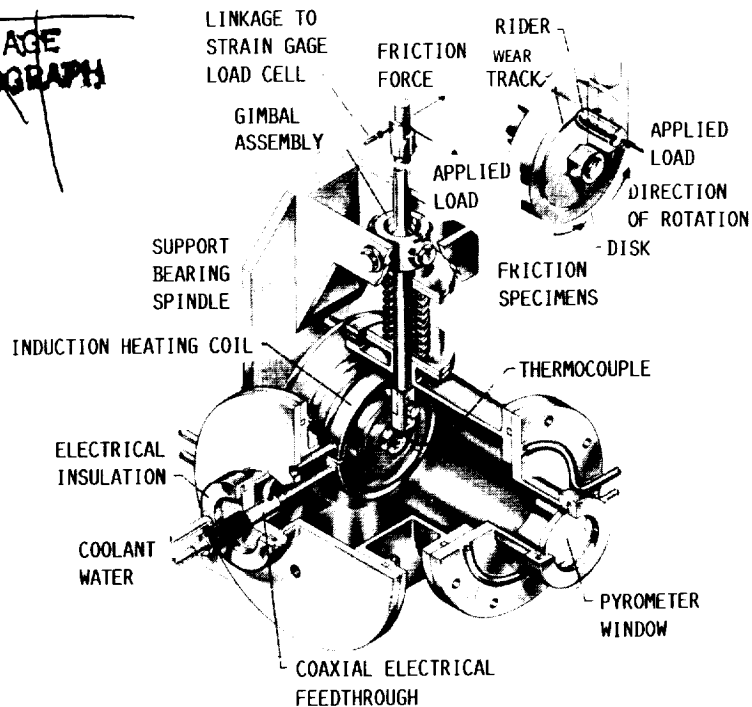

FIGURE 1. - PIN-ON-DISK TRIBOMETER.

ORIGINAL PAGE IS
OF POOR QUALITY

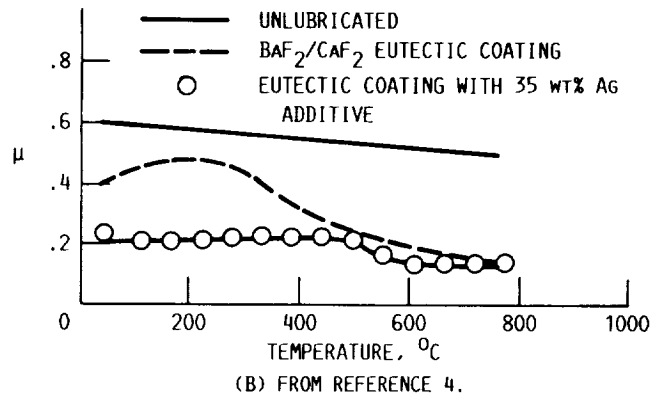
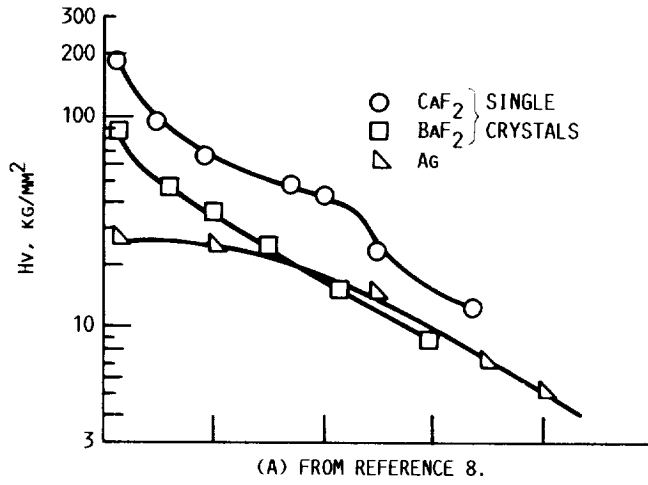

FIGURE 2. - EFFECT OF TEMPERATURE ON MICROHARDNESS AND FRICTION COEFFICIENTS OF COATING MATERIALS.



86-5935

CS-80-2014

FIGURE 3. - COMPRESSOR/TURBINE SHAFT SEAL OPERATES AT 650 °C.

ORIGINAL PAGE IS
OF POOR QUALITY

ORIGINAL PAGE IS
OF POOR QUALITY.

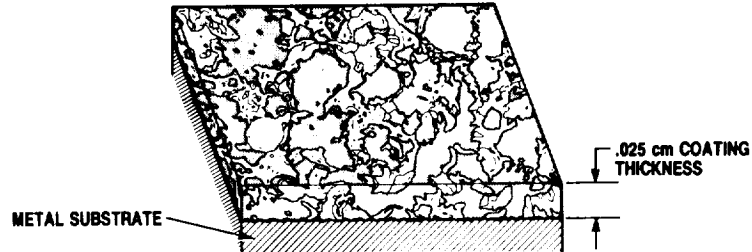

COMPOSITION

CHARACTERISTICS

- 32% NI ALLOY — WEAR AND OXIDATION RESISTANT METAL BONDED CARBIDE
- 48% Cr₃C₂
- 10% Ag — LOW TEMPERATURE START UP LUBRICANT WITH HIGH TEMPERATURE OXIDATION RESISTANCE
- 10% BaF₂/CaF₂ EUTECTIC — HIGH TEMPERATURE LUBRICANT

• LUBRICATES IN AIR, HELIUM, OR HYDROGEN TO +900 °C

CD-86-19883

C-86-1249

FIGURE 4. - THE CONCEPT OF PS200 - A PLASMA-SPRAYED COMPOSITE SOLID LUBRICANT COATING.

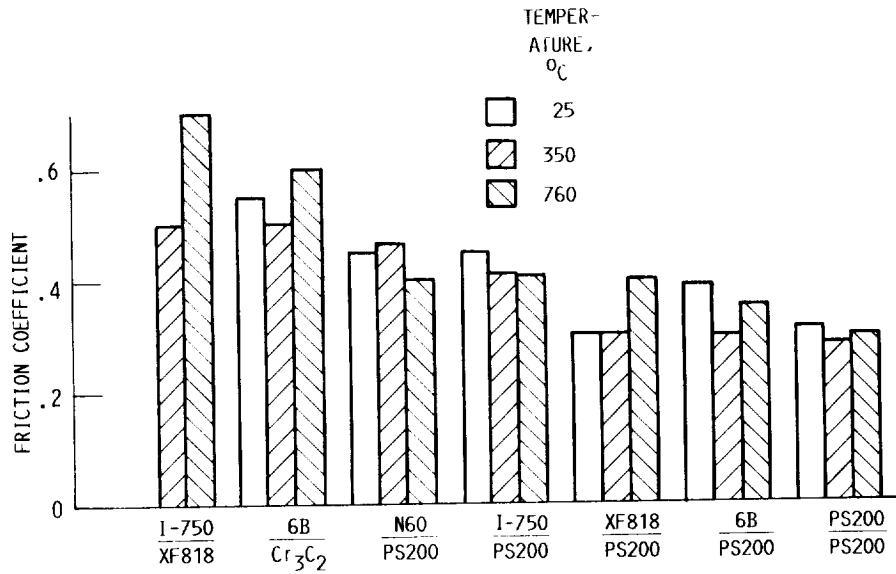

FIGURE 5. - SCREENING OF CANDIDATE PISTON RING MATERIALS.

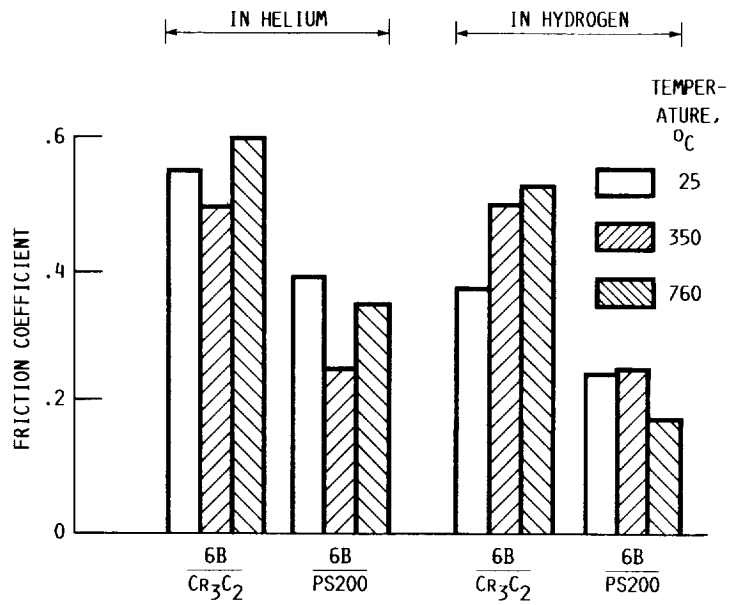

FIGURE 6. - BONDED CHROMIUM CARBIDE AND PS200 IN STIRLING ENGINE ATMOSPHERES.

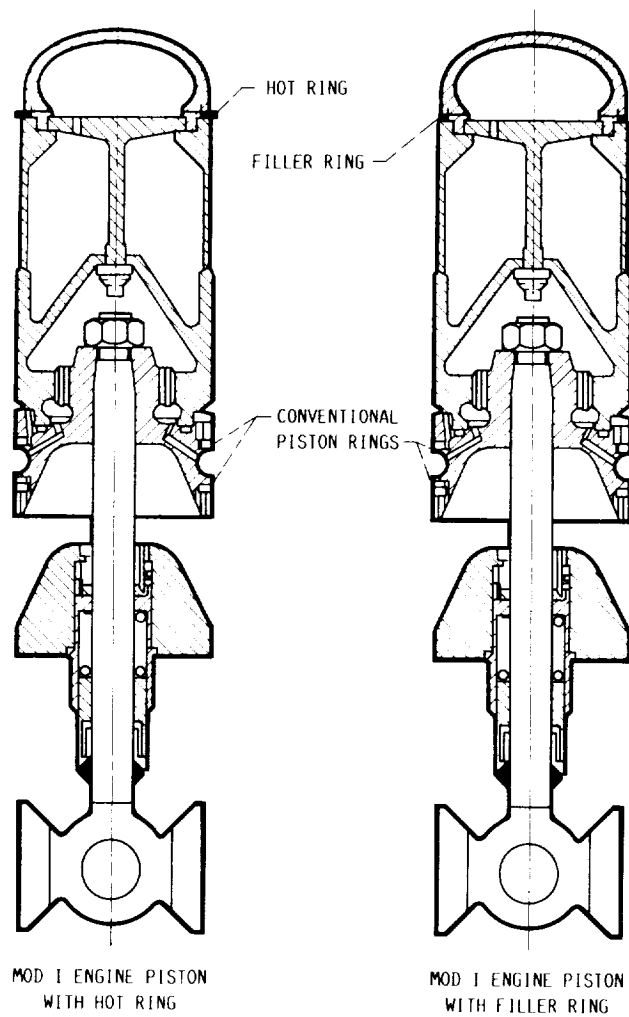
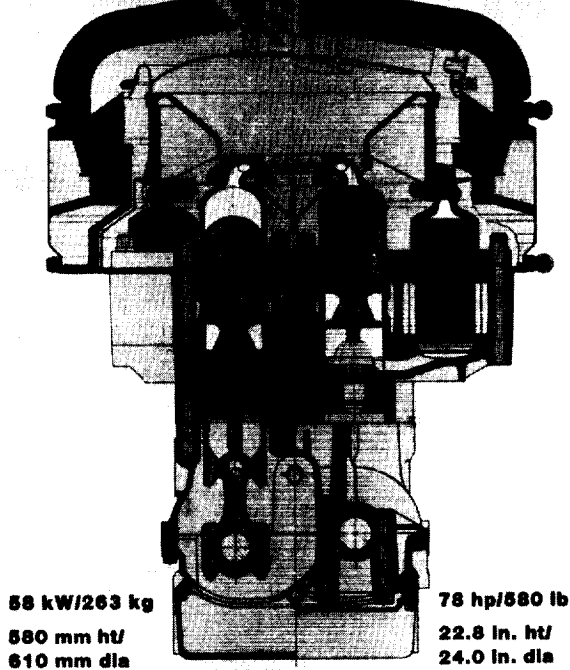

FIGURE 7. - PISTON CONFIGURATIONS.

UPGRADED MOD I

ORIGINAL PAGE IS
OF POOR QUALITY



C-84-1870

FIGURE 8. - MOD I AUTOMOBILE STIRLING ENGINE.

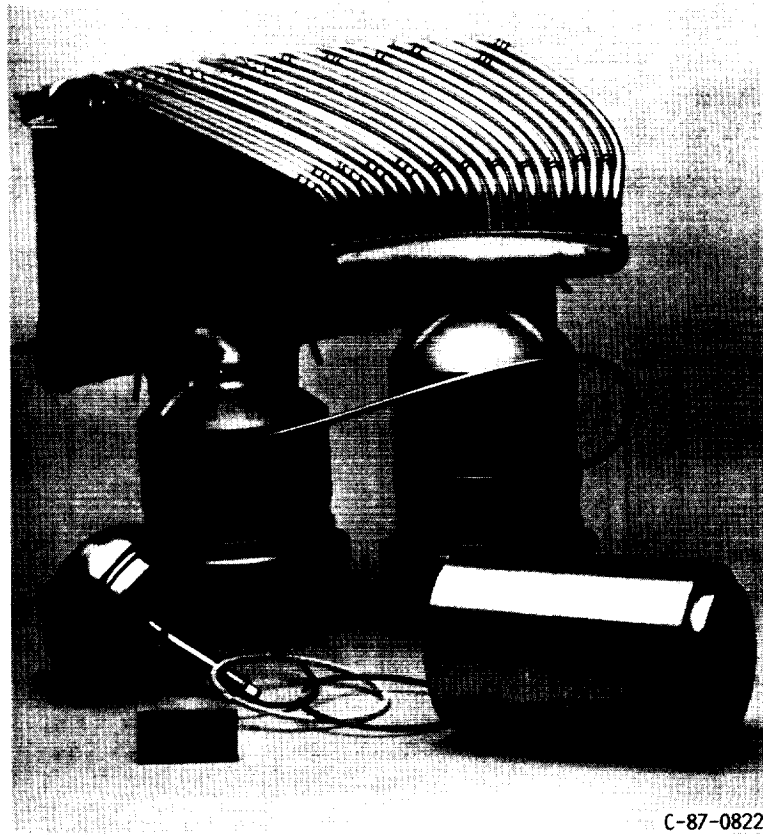

FIGURE 9. - HEATER HEAD QUADRANT AND A DISASSEMBLED "HOT RING" PISTON.

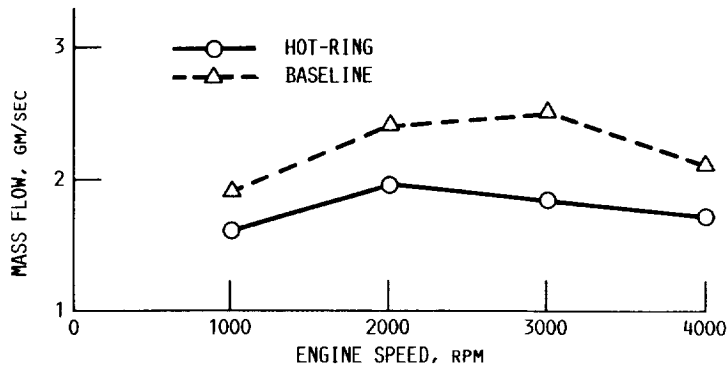

FIGURE 10. - SEAL LEAKAGE COMPARISON. 5 MPa MEAN PRESSURE.

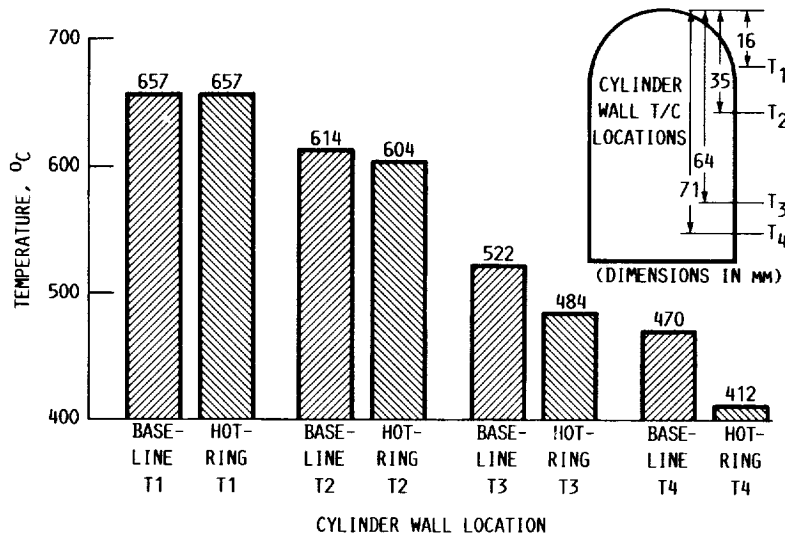
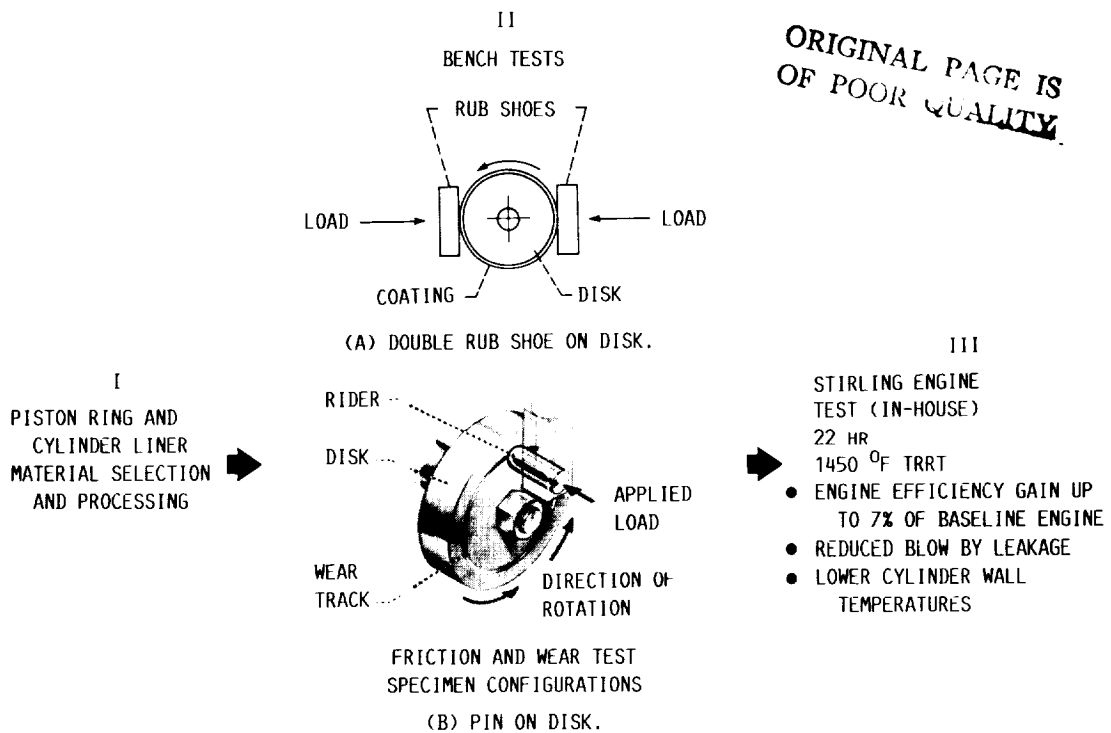

FIGURE 11. - CYLINDER WALL TEMPERATURE COMPARISON. 5 MPa MEAN PRESSURE, 1000 RPM.



C-87-3421

FIGURE 12. - PS200 COATING ON STIRLING ENGINE CYLINDER AFTER 22-HOUR ENGINE TEST WITH "HOT RINGS".



ORIGINAL PAGE IS
OF POOR QUALITY.

FIGURE 13. - PHASES OF "HOT PISTON RING" STIRLING ENGINE PROJECT.

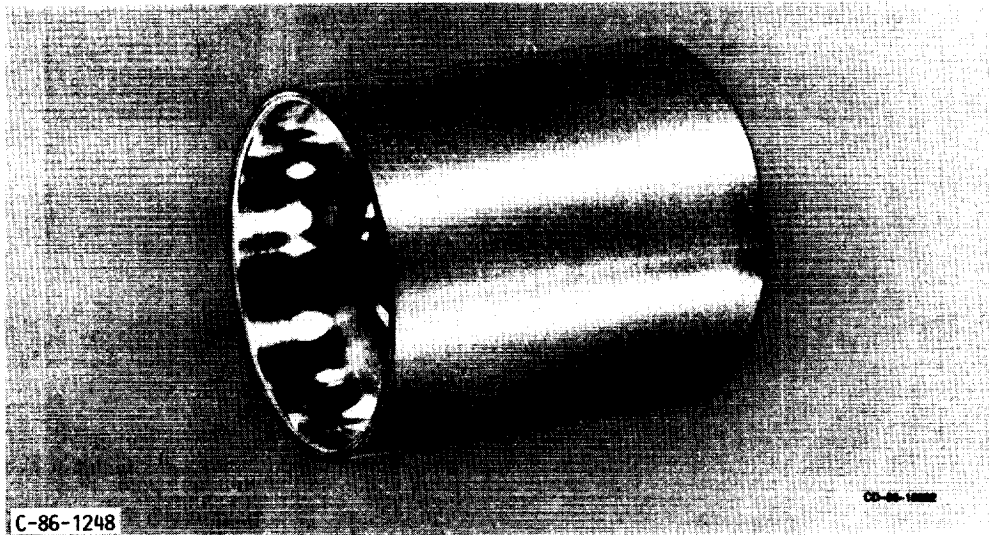

FIGURE 14. - GAS BEARING JOURNAL COATED WITH PS200 AND FINISHED BY DIAMOND GRINDING.

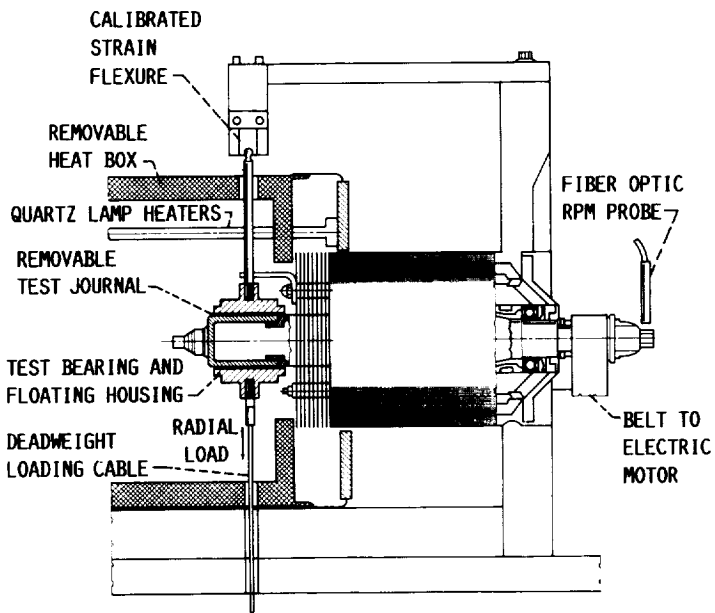

FIGURE 15. - FOIL BEARING TEST APPARATUS.

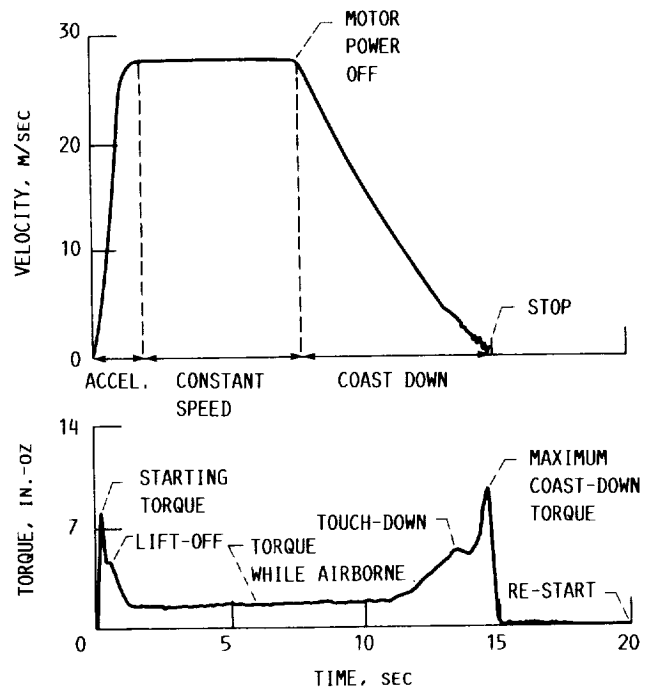

FIGURE 16. - SPEED AND TORQUE PROFILE DURING START-STOP TESTS OF COATINGS FOR FOIL GAS BEARINGS.

ORIGINAL PAGE IS
OF POOR QUALITY



National Aeronautics and
Space Administration

Report Documentation Page

| | | | | | |
|--|--|--|---|---|-------------------|
| 1. Report No. NASA TM-100276 | | 2. Government Accession No. | | 3. Recipient's Catalog No. | |
| 4. Title and Subtitle Hot Piston Ring/Cylinder Liner Materials - Selection and Evaluation | | | | 5. Report Date | |
| | | | | 6. Performing Organization Code | |
| 7. Author(s) Harold E. Sliney | | | | 8. Performing Organization Report No. E-3917 | |
| | | | | 10. Work Unit No. 506-43-1A | |
| 9. Performing Organization Name and Address National Aeronautics and Space Administration Lewis Research Center Cleveland, Ohio 44135-3191 | | | | 11. Contract or Grant No. | |
| | | | | 13. Type of Report and Period Covered Technical Memorandum | |
| 12. Sponsoring Agency Name and Address U.S. Department of Energy Office of Vehicle and Engine R&D Washington, D.C. 20545 | | | | 14. Sponsoring Agency Code DOE/NASA/50112-73 | |
| | | | | 15. Supplementary Notes Final Report. Prepared under Interagency Agreement DE-AI01-85CE50112. Prepared for the 1988 International Congress and Exposition, sponsored by the Society of Automotive Engineers, Inc., Detroit, Michigan, February 29 - March 4, 1988. | |
| 16. Abstract In current designs of the automotive (kinematic) Stirling engine, the piston rings are made of a reinforced polymer and are located near the bottom of the pistons because they cannot withstand the high temperatures in the upper cylinder region. Theoretically, efficiency could be improved if "hot piston rings" were located near the top of the pistons. This paper describes a program to select piston ring and cylinder coating materials to test this theory. Candidate materials were screened theoretically and in a pin on disk friction and wear test machine. Tests were performed in hydrogen at specimen temperatures up to 760 °C to simulate environmental conditions in the region of "hot piston ring" reversal. Based upon the results of these tests, a cobalt based alloy, Stellite 6B, was chosen for the piston rings and PS200, which consists of a metal-bonded chromium carbide matrix with dispersed solid lubricants, was chosen as the cylinder coating. Tests of a modified engine and a baseline engine showed that the hot ring did reduce specific fuel consumption by up to 7 percent for some operating conditions and averaged about 3 percent for all conditions evaluated. Related applications of high-temperature coatings for shaft seals and as back-up lubricants for gas bearings are also described. | | | | | |
| 17. Key Words (Suggested by Author(s)) Solid lubricant; Stirling hot piston ring lubricant; Plasma spray lubricant; Lubrication in hot hydrogen | | | 18. Distribution Statement Unclassified - Unlimited Subject Category 27 DOE Category UC-96 | | |
| 19. Security Classif. (of this report) Unclassified | | 20. Security Classif. (of this page) Unclassified | | 21. No of pages 17 | 22. Price* A02 |