

---

# VIRGINIA TECH

## CENTER FOR ADHESION SCIENCE

---

VPI-E-88-1  
CAS/ESM-88-1

January 1988

### NUMERICAL SOLUTION METHODS FOR VISCOELASTIC ORTHOTROPIC MATERIALS

K. C. Gramoll, Research Assistant  
Department of Engineering Science and Mechanics

D. A. Dillard, Assistant Professor  
Department of Engineering Science and Mechanics

H. F. Brinson, Professor  
Department of Engineering Science and Mechanics

Support for this work was provided by  
NASA-Ames Research Center (Contract No. NCC 2-71)  
Dr. Howard Nelson, Grant Monitor  
Test Engineering and Analysis Branch  
Mail Stop 213-3  
Moffett Field, CA 94035

(This technical report is substituted for the semi-annual  
status report.) Period covered March 15, 1987 - Sept. 1,  
1987.

---

VIRGINIA POLYTECHNIC INSTITUTE  
AND STATE UNIVERSITY

216 NORRIS HALL  
BLACKSBURG, VIRGINIA 24061

Telephone: (703) 961-6824  
TLX: EZLINK 9103331861  
VPI-BKS

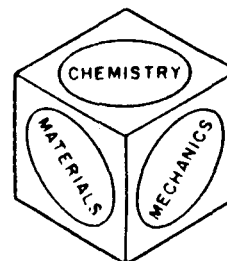

---

(NASA-CR-182381) NUMERICAL SOLUTION METHODS  
FOR VISCOELASTIC ORTHOTROPIC MATERIALS

Technical Report, 15 Mar. - 1 Sep. 1987

(Virginia Polytechnic Inst. and State Univ.)

59 p

N88-15874

Unclas

CSCL 11B G3/27 0120475

## REPORT DOCUMENTATION PAGE

1a. REPORT SECURITY CLASSIFICATION Unclassified			1b. RESTRICTIVE MARKINGS			
2a. SECURITY CLASSIFICATION AUTHORITY			3. DISTRIBUTION / AVAILABILITY OF REPORT Distribution Unlimited			
2b. DECLASSIFICATION / DOWNGRADING SCHEDULE						
4. PERFORMING ORGANIZATION REPORT NUMBER(S) VPI-E-88-1 CAS/ESM-88-1			5. MONITORING ORGANIZATION REPORT NUMBER(S)			
6a. NAME OF PERFORMING ORGANIZATION Virginia Polytechnic Institute and State University		6b. OFFICE SYMBOL (If applicable)	7a. NAME OF MONITORING ORGANIZATION			
6c. ADDRESS (City, State, and ZIP Code) Center for Adhesion Science Department of Engineering Science & Mechanics Blacksburg, VA 24061			7b. ADDRESS (City, State, and ZIP Code)			
8a. NAME OF FUNDING / SPONSORING ORGANIZATION NASA-Ames Research Center		8b. OFFICE SYMBOL (If applicable)	9. PROCUREMENT INSTRUMENT IDENTIFICATION NUMBER			
8c. ADDRESS (City, State, and ZIP Code) Test Engineering & Analysis Branch Mail Stop 213-3 Moffett Field, CA 94035			10. SOURCE OF FUNDING NUMBERS			
			PROGRAM ELEMENT NO.	PROJECT NO.	TASK NO.	WORK UNIT ACCESSION NO.
11. TITLE (Include Security Classification) Numerical Solution Methods for Viscoelastic Orthotropic Materials						
12. PERSONAL AUTHOR(S) K. C. Gramoll, D. A. Dillard and H. F. Brinson						
13a. TYPE OF REPORT Semi-Annual		13b. TIME COVERED FROM 7/87 TO 12/87		14. DATE OF REPORT (Year, Month, Day) 1/29/88		15. PAGE COUNT 56
16. SUPPLEMENTARY NOTATION						
17. COSATI CODES			18. SUBJECT TERMS (Continue on reverse if necessary and identify by block number)			
FIELD	GROUP	SUB-GROUP				
19. ABSTRACT (Continue on reverse if necessary and identify by block number) Numerical solution methods for viscoelastic orthotropic materials, specifically fiber reinforced composite materials, are examined. The methods included, classical lamination theory using time increments, direction solution of the Volterra Integral, Zienkiewicz's linear Prony series method, and a new method called Nonlinear Differential Equation Method (NDEM) which uses a nonlinear Prony series. The criteria used for comparison of the various methods include the stability of the solution technique, time step size stability, computer solution time length, and computer memory storage. The Volterra Integral allowed the implementation of higher order solution techniques but it had difficulties on solving singular and weakly singular compliance function. The Zienkiewicz solution technique, which requires the viscoelastic response to be modeled by a Prony series, works well for linear viscoelastic isotropic materials and small time steps. The new method, NDEM, uses a modified Prony series which allows nonlinear stress effects to be included and can be used with orthotropic nonlinear viscoelastic materials. The NDEM (over)						
20. DISTRIBUTION / AVAILABILITY OF ABSTRACT <input checked="" type="checkbox"/> UNCLASSIFIED/UNLIMITED <input type="checkbox"/> SAME AS RPT. <input type="checkbox"/> DTIC USERS			21. ABSTRACT SECURITY CLASSIFICATION			
22a. NAME OF RESPONSIBLE INDIVIDUAL			22b. TELEPHONE (Include Area Code)		22c. OFFICE SYMBOL	

19. Abstract (continued)

technique is shown to be accurate and stable for both linear and nonlinear conditions, and the computer solution time is minimal. Numerical examples and test cases are used to compare each solution method.

## Table of Contents

	Page
1. Introduction .....	3
2. Previous Work at VPI .....	4
3. Direct Integration of the Volterra Equation ....	7
4. Prony Series in Modeling Linear Viscoelastic Response .....	15
5. Nonlinear Differential Equation Method with the Prony Series .....	20
6. Verification of the Nonlinear Differential Equation Method .....	32
7. Summary and Conclusion .....	36
Appendix A .....	38

## 1. INTRODUCTION

Solving time dependent or viscoelastic problems for a homogeneous isotropic material can be involved and tedious. Extending this to nonhomogeneous and anisotropic materials such as layered fiber reinforced composite materials can be nearly impossible for closed form solutions. However, with numerical methods the designer or engineer of these materials can predict, with reasonable accuracy, the viscoelastic response without doing actual creep tests on each possible laminate.

The overall criteria for an acceptable viscoelastic numerical method is one that will be stable for large time steps, converge to the correct answer, and not take a tremendous amount of computer resources and time. In addition to these, the program that will use the method, will have to run on a microcomputer which further restricts the maximum run time and total memory. This will allow easy access to the program for design engineers and will make the design process, with its many 'what if' conditions and numerous rerunning proceed faster.

This report will examine various numerical methods that have been used in solving numerical viscoelastic methods. A new method, called the Nonlinear Differential Equation Method (NDEM), which is based on the prony series, will be introduced and compared with the current methods. The later part of this report will deal with the actual implementation and verification of the NDEM method.

## 2. PREVIOUS WORK AT VPI

The concept of predicting the viscoelastic response in any general laminate has been previously investigated by others at Virginia Polytechnic Institute and State University. Dillard, et al, [1,2] first formally proposed using known unidirectional material properties (obtained experimentally) of a composite lamina to predict the nonlinear viscoelastic response of any general laminate constructed from the same material by numerical methods. They examined the graphite/epoxy T300/934 composite system and closely predicted the response of various general laminate composites. Others, Tuttle [3] and Heil [4], have also used this basic concept to closely predict the response of other graphite/epoxy systems.

The numerical solution method used by Dillard [2] was based on classical lamination theory, with time incremented in a step fashion. The solution scheme first calculates the static stress and then begins the time step increments. The strain state is determined at  $t+\Delta t$ , using the stress state at time  $t$  and the viscoelastic constitutive equation for that particular material. The stress state is assumed to be constant throughout the time step from  $t$  to  $t+\Delta t$ . The new ply stresses are then determined at  $t+\Delta t$  based on the current creep strains and the applied mechanical load. This cycle is repeated, with the new stresses substituted back into the nonlinear compliance functions, until the stresses converge. A new time step is then taken and the process is repeated. The algorithm for calculating creep strains is similar to the classical lamination theory method of calculating the strains due to thermal loads. This procedure was implemented on an IBM mainframe computer and was called VISLAP (VIScoelastic LAMination Program) by Dillard [1,2].

There were three major difficulties with VISLAP and its numerical method. One, the basic algorithm of substituting old stresses back into the nonlinear compliance functions, and repeating the solution process until all stresses converge can have stability problems. This algorithm of successively substituting an unknown variable into a set of equations until convergence, called the Gauss-Seidel or successive substitution method, is not unconditionally stable. For example, if the coefficient matrix, [C], in the following set of equations, represented in matrix form,

$$[C]\{x\} = [B] \quad (1.1)$$

is not positive definite then it will not converge [5]. In some laminate cases, predominantly two fiber angle laminates, VISLAP will be unstable for this reason.

The second difficulty with VISLAP concerns the large time step size necessary to reach a solution of problems covering long time spans. If the time step is sufficiently large, stability problems will arise. VISLAP basically uses a first order forward integrating method, called the Euler Method [6], to solve for the creep strains at each step, which will have a maximum step size to remain stable.

In conjunction with the time step size problem is the third difficulty with VISLAP, the actual computer time and computer memory space needed for a solution grows exponentially with each additional time step. As each time step is taken, the creep strain must be recalculated over the entire time span back to the initial start time. This requires that all stresses at each time step must be stored and used for calculations at the next time step. This recalculation of the creep strain integral at each time step becomes more time consuming with each additional step. In order to minimize the computer solution time and memory, step sizes are increased in a logarithmic manner as the solution progresses. However, as stated above, large time steps can cause stability problems.

In order to overcome some of the problems in VISLAP but still retain its ability to calculate the complex, time dependent stress and strain state of an orthotropic composite laminate, various common numerical solution techniques will be investigated in the following sections. In addition to the those methods, a new method will be presented which resolves all the problems dealing with stability and solution time length.



### 3. DIRECT ITERATION OF THE VOLTERRA INTEGRAL

Viscoelastic problems naturally fall into the broad class of mathematical problems called convolution integral equations, of which the Volterra integral equation of the second kind is the most common. The general form of the Volterra equation is

$$u(x) = f(x) + \lambda \int_a^x k(x,t) u(t) dt \quad (3.1)$$

where  $u(x)$  is the unknown function and  $f(x)$ ,  $k(x,t)$ , and  $\lambda$  are known functions or constants. By simply changing the variable and function names and forms, the well known hereditary integral in viscoelasticity [7] becomes evident.

$$\epsilon(t) = \alpha(0)D(t) + \int_0^t D(t-\tau) \frac{\partial \sigma(\tau)}{\partial \tau} d\tau \quad (3.2)$$

where  $\epsilon(t)$  is the total strain,  $D(t)$  is the compliance function, and  $\sigma(\tau)$  is the stress function. This form is for a single homogeneous material. For a material made from multiple homogeneous layers, i.e., composite laminates, the total strain  $\epsilon(t)$  will be dependent on each of the stress in each of the layers. The strain can be written in terms of stress as

$$\epsilon(\sigma(t), t) = \alpha(0)D(t) + \int_0^t D(t-\tau) \frac{\partial \sigma(\tau)}{\partial \tau} d\tau \quad (3.3)$$

which is a Volterra integral of the second kind.

A simple example of such a system would be a one dimensional laminate material that is constructed from two parallel materials as illustrated in Fig. 3.1. The two materials have different compliance functions and the complete laminate is under a constant load. In this example

one material will be elastic and the other viscoelastic with  $\sigma_1$  and  $\sigma_2$  as the stresses in material 1 and 2, respectively and  $\sigma_0$  as the total applied stress. If  $D(t)$  represents any time dependent compliance function then

$$\varepsilon_2(t) = \sigma_2(0)D(t) + \int_0^t D(t-\tau) \frac{\partial \sigma_2(\tau)}{\partial \tau} d\tau \quad (3.4)$$

By using the relationships

$$\varepsilon_1(t) + \varepsilon_2(t) = \varepsilon(t) \quad (3.5a)$$

$$\sigma_1(t) + \sigma_2(t) = \sigma_0(t) = \sigma_0 \quad (3.5b)$$

$$E_1 \varepsilon(t) = \sigma_1(t) \quad (3.5c)$$

$$E_2 \varepsilon(t) = \sigma_2(t) \quad (3.5d)$$

it can be shown that

$$\frac{\sigma_1(t)}{E_1} - \frac{\sigma_2(t)}{E_2} = \int_0^t D(t-\tau) \frac{\partial \sigma_2(\tau)}{\partial \tau} d\tau + \sigma_2(0)D(t) \quad (3.6)$$

or

$$\begin{aligned} \sigma_2(t) \left[ \frac{E_1 + E_2}{E_1 E_2} \right] &= \sigma_0 \frac{E_1}{E_2} - E_1 \int_0^t D(t-\tau) \frac{\partial \sigma_2(\tau)}{\partial \tau} d\tau \\ &\quad - E_1 \sigma_2(0) D(t) \end{aligned} \quad (3.7)$$

This can be further simplified by integrating by parts to give

$$\sigma_2(t) = \frac{\sigma_0 E_1}{E_1 + E_2} + \frac{E_1 E_2}{E_1 + E_2} \int_0^t \frac{\partial D(t-\tau)}{\partial \tau} \sigma_2(\tau) d\tau \quad (3.8)$$

This form can be more easily evaluated since  $D(t)$  is usually given and its derivative can be calculated directly, where  $\sigma_2(t)$  is not known and its derivative is difficult to find. Equation 3.8 is in the standard convolution Volterra integral form which has been studied in detail by others [8-10] from a mathematical point of view. Once  $\sigma_2(t)$  is

known, the total strain  $\epsilon(t)$  can easily be calculated from Eq. 3.5. It should be noted that the one dimensional example presented a very simplified case and for a more natural multidimensional material the equation would not only be more complex, but there would be several coupled equations and not just one. However, to understand the basic principles and difficulties in solving the Volterra by numerical methods, the given example will be examined.

A closed form solution of Eq. 3.8 is possible for certain compliance functions,  $D(t)$ , such as a linear dashpot model,  $D(t) = t/\mu$ , or a Kelvin element model,  $D(t) = 1 - \exp[-t(E/\mu)]$ . However, compliance functions with solutions are scarce and are found for only simple functions. One important function that is widely used in linear viscoelastic analysis, and does not have a closed form solution, is the power law equation

$$D(t) = mt^n \quad (3.9)$$

where  $m$  and  $n$  are constants. Since closed form solutions are difficult to obtain and limited to certain compliance functions, numerical methods need to be applied to obtain most solutions.

Four concepts to be considered when employing numerical methods are convergence, error, stability, and solution time. The solution time length becomes especially critical when dealing with convolution Volterra integrals, due in part because  $\sigma(t)$  and  $\partial D(t-\tau)/\partial \tau$  continually change with each new time step. This requires the complete integral to be recalculated for each new time step. Unlike standard integrals, past results can not be used to calculate future points, but the total integral, from  $t_0$  ( $t=0$ ) to the current time,  $t$ , must be recalculated. At long times, i.e. large number of time steps, this method can require a tremendous amount of time and computer memory storage. If, however, the time steps can be varied, such as short steps at the start where the function is changing rapidly and long steps

towards the end where the function is changing slowly, then this method can be economical.

Convergence is generally not a problem for a non-singular kernel or compliance function,  $D(t)$ . However it does become a concern if the kernel is not well behaved or is singular. The power law (equation 3.9), which is used extensively in viscoelasticity, is classified as weakly singular, meaning the derivative at some point is singular or undefined (at zero for the power law). The solution of the integral can converge with weakly singular functions if the time steps around the weakly singular point are sufficiently small. Convergence of the power law and its associated problems will be demonstrated with an example later in this section.

Stability or numerical oscillations can occur in the solution of numerical problems. Even if the problem seems to converge and the error is small, it could diverge after a certain time step or step size. Two common causes of stability problems are: 1) the numerical precision of the computer or code, which leads to round off errors and truncation, and 2) the time step size. Generally the precision of the computer is not a problem or can be solved by upgrading to a better computer or programming language. On the other hand, most numerical solution techniques have a limit on the time step size before stability becomes a concern. All forward or explicit numerical integration techniques, which are generally used for the convolution integral, are not absolutely stable for all time step sizes [6,8,9,10]. This is a serious concern with viscoelastic analysis since increasing time steps are necessary to reduce the computer calculation time and memory size, as explained in the preceding paragraphs.

Error is associated with the accuracy of the computer and the algorithm used to solve the problem. Various algorithms have been developed for the solution of convolution integral equations which include, in ascending

order of accuracy, Euler, Modified Euler or trapezoidal, Simpson rule with trapezoidal end, Simpson rule with  $\frac{3}{8}$  rule, and Runge-Kutta. The higher order methods take more time for each time step but the accuracy is generally higher and larger time step sizes are possible. The trapezoidal algorithm will be presented in detail to demonstrate how the Volterra Integral can be solved numerically. Other methods are similar and will not be presented. However, the solution of the example problem presented earlier by all methods mentioned above will be compared at the end of this section.

An approximation for the convolution integral can be written

$$\int_0^{t_i} K(t_i - \tau) \alpha(\tau) d\tau \cong h \sum_{j=0}^i w_{ij} K(t_i - \tau_j) \alpha(\tau_j)$$

$$\cong h \sum_{j=0}^i w_{ij} K_{ij} \alpha(\tau_j) \quad i = 0, 1, 2, \dots, N \quad (3.10)$$

where  $h$  is the step size,  $K_{ij} = \partial D(t_i - \tau_j) / \partial \tau$ , and  $w_{ij}$  are the weights for the appropriate integration rule. For example, the weights for the trapezoidal method are  $w_{i0} = w_{ii} = \frac{1}{2}$ , and  $w_{ij} = 1$ . All of the preceding weights assume equal step sizes. In this manner the first few steps of Eq. 3.8 for the trapezoidal method are

$$\sigma_2(t_0=0) = \frac{\sigma_0 E_1}{E_1 + E_2}$$

$$\sigma_2(t_1) = \frac{\sigma_0 E_1}{E_1 + E_2} + \frac{E_1 E_2 h}{E_1 + E_2} \left[ w_{10} K_{10} \sigma_2(t_0) + w_{11} K_{11} \sigma_2(t_1) \right]$$

$$= \frac{\sigma_0 E_1}{E_1 + E_2} + \frac{E_1 E_2 h}{E_1 + E_2} \left[ \frac{1}{2} K_{11} \sigma_2(t_0) + \frac{1}{2} K_{11} \sigma_2(t_1) \right]$$

$$\sigma_2(t_2) = \frac{\sigma_0 E_1}{E_1 + E_2} + \frac{E_1 E_2 h}{E_1 + E_2} \left[ \frac{1}{2} K_{20} \sigma_2(t_0) + K_{21} \sigma_2(t_1) + \frac{1}{2} E_{22} \sigma_2(t_2) \right]$$

$$\sigma_2(t_i) = \frac{\sigma_0 E_1}{E_1 + E_2} + \frac{E_1 E_2}{E_1 + E_2} \frac{h}{2} \left[ K_{i0} \sigma_2(t_0) + K_{ii} \sigma_2(t_i) + \sum_{j=1}^{i-1} K_{ij} \sigma_2(t_j) \right] \quad (3.11a-d)$$

In each of these steps the unknown stress,  $\sigma_2(t_i)$ , can be factored out and solved for by manipulating the equation algebraically. However, if the kernel  $K(t)$  is nonlinear in terms of stress, then all  $i$  nonlinear equations would need to be solved simultaneously. This quickly becomes prohibitive since there will be thousands of time steps in a typical problem, which translates to solving thousands of nonlinear equations simultaneously. Similar relationships to equation 3.11 can be constructed for other integrating schemes. For higher order methods such as the Simpson rule or Runge-Kutta, a starting procedure needs to be used which should be of the same order of magnitude in accuracy. Various starting techniques can be found in the literature [11-14].

To evaluate the use of the Volterra integral for viscoelastic materials the one dimensional example described at the beginning of this section (Fig 3.1) will be used. Two different but common compliance functions,  $D(t)$ , were chosen to be examined, a dashpot,  $D(t) = t/\mu$ , where  $\mu$  is the viscosity constant of the dashpot and a power law,  $D(t) = mt^n$ , where  $m$  and  $n$  are assumed given.

The dashpot function has a exact solution to Eq. 3.8, which will be used to verify the numerical results,

$$\sigma_2 = \sigma_0 \frac{E_2}{E_1 + E_2} e^{-\lambda t} \quad (3.12)$$

where  $\lambda = E_1 E_2 / \mu (E_1 + E_2)$  and  $\sigma_0$  is constant. Five different

integrating techniques were used to solve the example problem: Euler, trapezoidal, trapezoidal with 3-point starting technique, Simpson with 3-point starting technique and trapezoidal rule for even last data point, and Simpson with 3-point starting technique and 3/8 rule for the even last data point. The results are shown on Fig 3.2. Even though the time step,  $h$ , was large, all but the Euler method are within acceptable accuracy limits.

The second compliance function to be examined, the power law, has no closed form solution to compare with the numerical results. However, by examining the results of various integrating techniques the solution can be deduced. The same five integrating techniques used for the dashpot test case were also used for the power law (constants  $m = 5$  and  $n = 0.2$ ) and the results are shown in Fig. 3.3. The time step was  $h = 0.1$ , two magnitudes smaller than for the dashpot example, but unlike the dashpot results the power law results vary and even oscillate. If the step size is reduced, the solution tends to converge to smaller values (Fig. 3.4) and it becomes evident that the time step size affects the solution convergence. The solution does seem to slowly approach a limiting value as  $h \rightarrow 0.0$ .

The solution of the power law function is inaccurate because it is a weakly singular function at zero. The derivative of the power law at zero is infinity and the derivative changes rapidly for small values of time. This requires very small time steps, ( $\cong 10^{-6}$ ) near the origin for any of the numerical integration techniques to converge. However, with small time steps, the time required to solve the problem increases tremendously which then limits the time span. The time step size can be increased as the time becomes larger but there will be an upper limit on step size before stability difficulties develop.

In conclusion, the direct numerical integration of the Volterra integral for linear viscoelastic problems is not

recommended. The biggest difficulty was the long run times necessary for any numerical solution to converge when using the power law compliance function. This was caused by the weakly singular nature of the power law. Other difficulties would be the inclusion of nonlinear stress effects, thus creating a large number (on the order of hundreds) nonlinear equation that would need to be solved simultaneously. It should also be noted that the above difficulties would be magnified for multidimensional materials such as orthotropic composite materials.



#### 4. Prony Series in Modeling Linear Viscoelastic Response

The Prony series is a method to model viscoelastic response that is derived from a series of Kelvin elements. This series can best be understood by first looking at a single Kelvin element, which has a spring and dashpot in parallel as shown in Fig. 4.1. The Kelvin element needs two parameters to describe its response to a given load or displacement, the spring constant,  $E$ , and the dashpot viscosity,  $\mu$ . The load or stress,  $\sigma_0$  and the strain,  $\epsilon$ , can be related by summing the stress in both the spring and dashpot.

$$\sigma_s + \sigma_d = \sigma_0 \quad (4.1)$$

Substituting the constitutive equations for a spring and dashpot gives

$$\epsilon E + \dot{\epsilon} \mu = \dot{\sigma}_0 \quad (4.2)$$

Solving for  $\epsilon$ , and assuming  $\sigma_0$  is constant will give

$$\epsilon = \frac{\sigma_0}{E} \left( 1 - e^{-Et/\mu} \right) \quad (4.3)$$

This can be generalized with a series of Kelvin elements as

$$\epsilon = \sigma_0 \sum_{i=1}^n \frac{1}{E_i} \left( 1 - e^{-E_i t / \mu_i} \right) \quad (4.4)$$

where  $n$  is the total number of Kelvin elements in the series. As a further generalization, a single spring can be placed in series with the Kelvin elements such that

$$\epsilon = \frac{\sigma_0}{E_s} + \sigma_0 \sum_{i=1}^n \frac{1}{E_i} \left( 1 - e^{-E_i t / \mu_i} \right) \quad (4.5)$$

where  $E_s$  is the spring constant in the single spring.

Equation 4.5 is referred to as a Prony series. Prony series

can model the creep of a viscoelastic material accurately if the retardation times ( $\tau = \mu/E$ ) of the individual Kelvin elements are properly spaced. Since one Kelvin element influences the strain over about  $1\ 1/2$  decades of time, the retardation times should be spaced about one per decade of time that is being modeled.

One advantage of the Prony series is its ability to accurately represent any data over any time span if enough elements are used. This is especially useful if that data is not uniform or does not conform to any general curve shape. Of course, this is also a disadvantage since a large number of material properties, two for every element, are required. In a contrast, the linear power only has 3 parameters,  $\epsilon = \epsilon_0 + mt^n$ , to describe the viscoelastic strain response. Another major difference between the Prony series and the power law is the extrapolation of creep response outside the actual collected data range. The Prony series is derived or fitted only to actual data and after the last data point the series stops. The power law is also derived from actual data but after the last data point the equation still indicates or predicts a change in creep over time. Although, prudent engineering prohibits the use or extrapolation of results past actual collected data, it is still useful to understand the expected creep response or trend.

One of the most important advantages of the Prony series is that each Kelvin element can be solved independently as a differential equation (see equation 4.2) and then the solutions can be summed together. A differential equation in the form of equation 4.2, allows the use of common and well understood numerical methods for solving differential equations. Since the problem has been transformed to solving differential equations and not a convolution integral (i.e., the Volterra Integral) the solution techniques are simpler and easier to implement on a

computer. The results of each time step no longer need to be stored and reused to calculate future creep steps like the convolution method requires. All information needed to take another time step is available in the current solution of each differential equation.

The concept of using Kelvin elements and their respective differential equations to solve viscoelastic problems was presented by Zienkiewicz, et al., [15,16]. They used the differential equation formulation in conjunction with finite elements method to successfully solve geometrically complex problems. The constant stress solution, Eq. 4.3, was used to develop a solution technique. By taking a small time step, Eq. 4.3 can be written as

$$\begin{aligned}
 (\epsilon_c)_{t+\Delta t} &= \frac{\sigma_o}{E} \left[ 1 - e^{-\frac{E}{\mu}(t+\Delta t)} \right] \\
 &= \frac{\sigma_o}{E} \left[ e^{-\frac{E}{\mu}\Delta t} - e^{-\frac{E}{\mu}\Delta t} \right] + \frac{\sigma_o}{E} \left[ 1 - e^{-\frac{E}{\mu}(t+\Delta t)} \right] \\
 &= e^{-\frac{E}{\mu}\Delta t} \left[ \frac{\sigma_o}{E} \right] \left[ 1 - e^{-\frac{E}{\mu}t} \right] + \frac{\sigma_o}{E} \left[ 1 - e^{-\frac{E}{\mu}\Delta t} \right] \\
 &= e^{-\frac{E}{\mu}\Delta t} (\epsilon_c)_t + \frac{\sigma_o}{E} \left[ 1 - e^{-\frac{E}{\mu}\Delta t} \right] \quad (4.6)
 \end{aligned}$$

where  $(\epsilon_c)_t$  is the strain from the previous time step solution and  $\Delta t$  is the current time step size. If the stress is constant for all time steps, Eq. 4.6 will give an exact answer to Eq. 4.2. However in most practical problems the stress is constantly changing due to relaxation, temperature changes, load changes, etc. If the time step is small and the stress changes gradually, then Eq. 4.6 gives accurate results as shown by Zienkiewicz.

In order to describe the viscoelastic response over long periods of time, Kelvin elements with different

relaxation times may be combined in series as shown in Fig. 4.2. Each Kelvin element is described by a differential equation and the solution of which can be written in the form of Eq. 4.6. These solutions can then be summed together to give

$$\epsilon_T = \sum_{i=0}^l \left( \epsilon_c^i \right)_{t+\Delta t} = \sum_{i=0}^l \left\{ e^{-E_i \Delta t / \mu_i} \left( \epsilon_c^i \right)_t + \frac{\sigma_o^i}{E_i} \left[ 1 - e^{-E_i \Delta t / \mu_i} \right] \right\} \quad (4.7)$$

where  $l$  is the total number of Kelvin elements in the series.

Solution techniques based on Eq. 4.7 have been widely used for stress analysis of linear isotropic materials for limited time spans [16-18]. There are three main deficiencies with Eq. 4.7 formulation. First, only linear viscoelastic materials can be analyzed, whereas many of today's materials, specifically plastics, are nonlinear. A nonlinear viscoelastic material will have a different compliance and rate of change of compliance at different stress levels. Since Eq. 4.7 does not account for these nonlinearities, the numerical results will possibly not agree with actual experimental results. Some researchers [17] have extended Eq. 4.7 to include nonlinear effects with limited success. Second, the time step size has an upper limit at which the numerical solution technique will become unstable since the equation is a forward difference or an explicit method. Only an implicit numerical method can be 'unconditionally stable' for all time step sizes [6]. Limiting the time step size in a viscoelastic problem, which can span many decades of time, is a concern since large time steps become necessary toward the end of the problem. Third, Eq. 4.7 is only a first order numerical solution technique, commonly referred to as the 'Euler Method', for differential

equations. To increase the accuracy and/or decrease the number of steps necessary, a higher order solution technique should be employed.

Other general problems with Eq. 4.7 are the constant stress assumption at each time step and the difficulties of using it with orthotropic materials. However, the two advantages of not having to store all past results and not having to recalculate strain at previous time steps for every new time step taken overshadows the disadvantages. The following section will present a method to extend the Prony series method to solve orthotropic, nonlinear viscoelastic problems for long time spans.

## 5. NONLINEAR DIFFERENTIAL EQUATION METHOD WITH THE PRONY SERIES

The basic concepts of Kelvin elements and Prony series presented in section 4 will be utilized and extended to include nonlinear effects, viscoelastic orthotropic materials, and unconditionally stable time steps. It was these three difficulties that limited the use of the Zienkiewicz differential equation method for viscoelastic analysis.

The basic differential equation for a single Kelvin element can be written as (see Eq. 4.2 and Fig 4.1)

$$\dot{\epsilon} = \frac{D}{\lambda} \sigma - \frac{1}{\lambda} \epsilon \quad (5.1)$$

Where  $D$  is the compliance of the spring ( $1/E$ ) and  $\lambda$  is the retardation time ( $\mu/E$ ). Both the compliance and retardation time are considered known and can be obtained from the Prony series used to describe the viscoelastic response (see Eqs. 4.4 and 4.5). A single differential equation of the form Eq. 5.1 can be used for each term in a given Prony series.

Up to this point only one material property has been dealt with at a time. However, all materials are defined, as a minimum, by at least two material properties which need to be considered simultaneously. Isotropic materials are generally described by Young's Modulus and Poisson's ratio, whereas orthotropic materials have four independent material in-plane properties which are commonly referred to as the fiber direction stiffness ( $E_{11}$ ), the transverse direction stiffness ( $E_{22}$ ), the shear modulus ( $E_{66}$  or  $G_{12}$ ), and Poisson's ratio of the fiber direction to transverse direction ( $\nu_{12}$ ). In condensed matrix form, these properties relate stress and strain as

$$\begin{Bmatrix} \epsilon_1 \\ \epsilon_2 \\ \epsilon_{12} \end{Bmatrix} = \begin{bmatrix} 1/E_{11} & -\nu_{12}/E_{11} & 0 \\ -\nu_{12}/E_{11} & 1/E_{22} & 0 \\ 0 & 0 & 1/E_{\sigma\sigma} \end{bmatrix} \begin{Bmatrix} \sigma_1 \\ \sigma_2 \\ \sigma_{12} \end{Bmatrix} \quad (5.2)$$

where  $\epsilon_1$  and  $\sigma_1$  are strain and stress, respectively, in the fiber direction,  $\epsilon_2$  and  $\sigma_2$  are strain and stress in the transverse direction, respectively, and  $\epsilon_{12}$  and  $\sigma_{12}$  are shear strain and stress, respectively. The matrix containing  $E_{11}$ ,  $E_{22}$ ,  $\nu_{12}$ , and  $E_{\sigma\sigma}$  is referred to as the compliance matrix [S] which can be written as

$$\begin{Bmatrix} \epsilon_1 \\ \epsilon_2 \\ \epsilon_{12} \end{Bmatrix} = \begin{bmatrix} S_{11} & S_{12} & 0 \\ S_{12} & S_{22} & 0 \\ 0 & 0 & S_{\sigma\sigma} \end{bmatrix} \begin{Bmatrix} \sigma_1 \\ \sigma_2 \\ \sigma_{12} \end{Bmatrix} \quad (5.3)$$

where  $S_{11}$ ,  $S_{12}$ ,  $S_{22}$ , and  $S_{\sigma\sigma}$  are the four independent properties needed to characterize an orthotropic material. These four terms will be referred to as  $S_q$  where  $q$  goes from 1 to 4, such that  $S_{11} = S_1$ ,  $S_{12} = S_2$ ,  $S_{22} = S_3$ , and  $S_{\sigma\sigma} = S_4$ . This numbering convention becomes necessary, as will be seen later, to differentiate these orthotropic compliance terms from the rotated compliance matrix terms, which will use the double subscripts ( $S_{ij}$ ).

The viscoelastic portion of each of the unrotated,  $S_q$  terms can be described by a Prony series. The general form is

$$S_q = \sum_{l=1}^n {}_l D_q \left[ 1 - e^{-t/\lambda_l} \right] \quad l = 1, 2, 3, \dots, n \quad (5.4)$$

where  ${}_l D_q$  is the compliance coefficient variable for the  $l^{\text{th}}$  Kelvin unit in the  $q^{\text{th}}$  direction and  $\lambda_l$  is the retardation time. Both  ${}_l D_q$  and  $\lambda_l$  are unknowns that need to be determined from experimental data. However, the retardation

time,  $\lambda_l$  can be forced to be the same for each  $l^{\text{th}}$  Kelvin element in each of the four material directions. This is reasonable since  $\lambda_l$  is predetermined or fixed when fitting a Prony series to experimental data with only  $D_{lq}$  allowed to vary.

Furthermore, each layer in a composite laminate will have a set of four  $S_q$  terms describing its compliance matrix. If all the layers are of the same type of material and not rotated, i.e. all  $0^\circ$  direction, then  ${}^k S_q = S_q$  where  $k$  is the ply layer in the laminate and Eq. 5.3 becomes

$$\begin{Bmatrix} \epsilon_x \\ \epsilon_y \\ \epsilon_{xy} \end{Bmatrix}^k = \begin{bmatrix} \sum_{l=1}^n {}^{kl} S_1 & \sum_{l=1}^n {}^{kl} S_2 & 0 \\ \sum_{l=1}^n {}^{kl} S_2 & \sum_{l=1}^n {}^{kl} S_3 & 0 \\ 0 & 0 & \sum_{l=1}^n {}^{kl} S_4 \end{bmatrix} \begin{Bmatrix} \sigma_x \\ \sigma_y \\ \sigma_{xy} \end{Bmatrix}^k \quad (5.5)$$

However, if ply  $k$  is rotated, then the compliance matrix becomes fully populated,

$$\begin{Bmatrix} \epsilon_x \\ \epsilon_y \\ \epsilon_{xy} \end{Bmatrix}^k = \begin{bmatrix} \sum_{q=1}^4 \sum_{l=1}^n {}^{kl} S_{q11} & \sum_{q=1}^4 \sum_{l=1}^n {}^{kl} S_{q12} & \sum_{q=1}^4 \sum_{l=1}^n {}^{kl} S_{q1\sigma} \\ \sum_{q=1}^4 \sum_{l=1}^n {}^{kl} S_{q12} & \sum_{q=1}^4 \sum_{l=1}^n {}^{kl} S_{q22} & \sum_{q=1}^4 \sum_{l=1}^n {}^{kl} S_{q2\sigma} \\ \sum_{q=1}^4 \sum_{l=1}^n {}^{kl} S_{q1\sigma} & \sum_{q=1}^4 \sum_{l=1}^n {}^{kl} S_{q2\sigma} & \sum_{q=1}^4 \sum_{l=1}^n {}^{kl} S_{q\sigma\sigma} \end{bmatrix} \begin{Bmatrix} \sigma_x \\ \sigma_y \\ \sigma_{xy} \end{Bmatrix}^k \quad (5.6)$$

Where each of the  ${}^{kl} S_{qij}$  terms can be calculated from the transformation matrices [19,20]. Similarly, the compliance coefficients,  $D_{lq}$ , which will be used exclusively from this point on, can also be written in matrix form and rotated giving



$$\begin{Bmatrix} \varepsilon_x \\ \varepsilon_y \\ \varepsilon_{xy} \end{Bmatrix}^k = \begin{bmatrix} \sum_{q=1}^4 \sum_{l=1}^n kl^D_{q11} & \sum_{q=1}^4 \sum_{l=1}^n kl^D_{q12} & \sum_{q=1}^4 \sum_{l=1}^n kl^D_{q1\sigma} \\ \sum_{q=1}^4 \sum_{l=1}^n kl^D_{q12} & \sum_{q=1}^4 \sum_{l=1}^n kl^D_{q22} & \sum_{q=1}^4 \sum_{l=1}^n kl^D_{q2\sigma} \\ \sum_{q=1}^4 \sum_{l=1}^n kl^D_{q1\sigma} & \sum_{q=1}^4 \sum_{l=1}^n kl^D_{q2\sigma} & \sum_{q=1}^4 \sum_{l=1}^n kl^D_{q\sigma\sigma} \end{bmatrix} \begin{Bmatrix} \sigma_x \\ \sigma_y \\ \sigma_{xy} \end{Bmatrix}^k \quad (5.6a)$$

where for fiber direction term,  $q = 1$ ;

$$\begin{aligned} kl^D_{111} &= m_k^4 kl^D_1 \\ kl^D_{112} &= m_k^2 n_k^2 kl^D_1 \\ kl^D_{11\sigma} &= 2 n_k m_k^3 kl^D_1 \\ kl^D_{122} &= n_k^4 kl^D_1 \\ kl^D_{12\sigma} &= 2 m_k n_k^3 kl^D_1 \\ kl^D_{1\sigma\sigma} &= 4 m_k^2 n_k^2 kl^D_1 \end{aligned}$$

for fiber/transverse coupling term,  $q = 2$ ;

$$\begin{aligned} kl^D_{211} &= 2 m_k^2 n_k^2 kl^D_2 \\ kl^D_{212} &= (m_k^4 + n_k^4) kl^D_2 \\ kl^D_{21\sigma} &= 2 m_k n_k (n_k^2 - m_k^2) kl^D_2 \\ kl^D_{222} &= 2 n_k^2 m_k^2 kl^D_2 \\ kl^D_{22\sigma} &= 2 m_k n_k (m_k^2 - n_k^2) kl^D_2 \\ kl^D_{2\sigma\sigma} &= -8 m_k^2 n_k^2 kl^D_2 \end{aligned}$$

for transverse direction term,  $q = 3$ ;

$$\begin{aligned} kl^D_{311} &= n_k^4 kl^D_3 \\ kl^D_{312} &= m_k^2 n_k^2 kl^D_3 \\ kl^D_{31\sigma} &= -2 m_k n_k^3 kl^D_3 \\ kl^D_{322} &= m_k^4 kl^D_3 \\ kl^D_{32\sigma} &= -2 n_k m_k^3 kl^D_3 \end{aligned}$$

$${}_{kl}D_{300} = 4 m_k^2 n_k^2 {}_{kl}D_3$$

for shear term,  $q = 4$ ;

$$\begin{aligned} {}_{kl}D_{411} &= m_k^2 n_k^2 {}_{kl}D_4 \\ {}_{kl}D_{412} &= (n_k^4 - m_k^4) {}_{kl}D_4 \\ {}_{kl}D_{410} &= m_k n_k (n_k^2 - m_k^2) {}_{kl}D_4 \\ {}_{kl}D_{422} &= n_k^2 m_k^2 {}_{kl}D_4 \\ {}_{kl}D_{420} &= 2 m_k n_k (m_k^2 - n_k^2) {}_{kl}D_4 \\ {}_{kl}D_{400} &= (m_k^2 - n_k^2)^2 {}_{kl}D_4 \end{aligned} \quad (5.7a-x)$$

where  $m_k = \cos(\theta_k)$ ,  $n_k = \sin(\theta_k)$ ,  ${}_{kl}D_q$  is the unrotated and  ${}_{kl}D_{qij}$  the rotated compliance terms ( $\theta$  is the angle of rotation). Although it seems unnecessary and overly complex to split  ${}_{kl}D_{qij}$  into four parts, one for each material property direction, this allows different stress nonlinear effects to be modeled in each of the four direction, which will be developed later.

Unlike the compliance terms,  ${}_{kl}D_q$ , the relaxation times,  $\lambda_l$ , are constrained to be the same in each of the four directions which eliminates the need to rotate them. All layers or plies are also assumed to be made of the same material which alleviates the need to kept track of the ply number when dealing with  $\lambda_l$ . There are, however, some limitations on  $\lambda_l$ . There should be at least one Kelvin element for every  $1\frac{1}{2}$  decades of time that is being examined since the effect of the Kelvin element is only felt over that time period. The common practice is one Kelvin element, thus one relaxation time,  $\lambda_l$ , for every decade of time. For orthotropic materials it is further convenient to set  $\lambda_l$  the same in all material property directions. A typical Prony series might have  $\lambda_1 = 1$ ,  $\lambda_2 = 10$ ,  $\lambda_3 = 100$ , etc., for each ply and direction.

If all the stresses in each layer and direction were

constant, then the time dependent strain could be easily calculated at this point by substituting the Prony series (Eq. 5.4) for each direction into the constitutive equations relating stress and strain (Eq. 5.6) and solve for the desired time. However the stresses in each ply can in fact change with time which means stress is a function of the current strain rate as well as the current strain. Even though the restriction of constant stress was used to get the original Prony series in characterizing the material, that restriction is not necessary true in the actual numerical solution process. The matrix Eqs. 5.3, 5.5, and 5.6 are still needed to show how the compliance terms can be manipulated and rotated to obtain the  ${}_{kl}D_{qij}$  terms but they are not used to obtain the strain. Instead the strain and stress equilibrium equation can be employed to calculate the strain. However a expression for the strain without the strain rate must first be developed.

The original differential equation, Eq. 5.1, can be rewritten as

$${}_{kl}\dot{\epsilon}_{ij} = \sum_{q=1}^4 \left[ \frac{{}_{kl}D_{qij}}{\lambda_l} \right] {}_{kl}\sigma_{ij} - \frac{{}_{kl}\epsilon_{ij}}{\lambda_l} \quad (5.8)$$

where  ${}_{kl}\dot{\epsilon}_{ij}$  and  ${}_{kl}\epsilon_{ij}$  are the strain rate and strain, respectively, and  ${}_{kl}\sigma_{ij}$  is the stress in each Kelvin element,  $l$ , ply,  $k$ , compliance direction,  $q$ , and rotated position,  $(i,j)$ . This equation can be approximated by

$$\frac{{}_{kl}\epsilon_{ij}^{t+1} - {}_{kl}\epsilon_{ij}^t}{\Delta t} = \sum_{q=1}^4 \left[ \frac{{}_{kl}D_{qij}}{\lambda_l} \right] {}_{kl}\sigma_{ij}^{t+1} - \frac{{}_{kl}\epsilon_{ij}^{t+1}}{\lambda_l} \quad (5.9)$$

where  $\Delta t$  is the time step size,  $t+1$  is the new time and  $t$  is the old time. This particular approximation is called a Backward Euler Method (BEM) and is classified as a first order implicit method. By using an implicit method, the solution,  ${}_{kl}\epsilon_{ij}^{t+1}$ , will be unconditionally stable regardless

of the time step size. This is not to say that it will converge to the correct answer but it will not diverge or blow up. This 'unconditionally stable' characteristic only holds true for the first and second order implicit numerical approximations [6]. Higher order implicit methods and all explicit methods are only conditionally stable, i.e. has a maximum time step before it might diverge.

The BEM, a first order implicit method, will be examined in detail in the remainder of this section. The second order implicit method, call the Backward Trapezoidal Method (BTMD) is developed in appendix A. Equation 5.9 can be rearranged to give

$${}_{kl} \epsilon_{ij}^{t+1} \left( 1 + \frac{h}{\lambda_l} \right) = h \sum_{q=1}^4 \left[ \frac{{}_{kl} D_{qij}}{\lambda_l} \right] {}_{kl} \sigma_{ij}^{t+1} + {}_{kl} \epsilon_{ij}^t$$

or

$${}_{kl} \epsilon_{ij}^{t+1} = \frac{h}{(\lambda_l + h)} \sum_{q=1}^4 [{}_{kl} D_{qij}] {}_{kl} \sigma_{ij}^{t+1} + \frac{{}_{kl} \epsilon_{ij}^t \lambda_l}{(\lambda_l + h)} \quad (5.10)$$

where  $\Delta t = h$ . The unknowns are  ${}_{kl} \epsilon_{ij}^{t+1}$  and  ${}_{kl} \sigma_{ij}^{t+1}$  while  $h$ ,  $\lambda_l$ , and  ${}_{kl} D_{qij}$  are given and  ${}_{kl} \epsilon_{ij}^t$  is known from the previous time step. The total creep strain,  ${}^c_k \epsilon_i$ , for a particular direction,  $i$ , and layer,  $k$ , is simply the sum of all the creep strain in that direction

$${}^c_k \epsilon_i = \sum_{j=1}^3 \sum_{l=1}^n \left\{ {}_{kl} \epsilon_{ij}^{t+1} \right\} \quad (5.11)$$

It should be noted that Eq. 5.10 is only for linear viscoelastic material. In order to include nonlinear stress effects,  ${}_{kl} D_{qij}$  needs to be modified to become a function of stress. This is easily done by multiplying  ${}_{kl} D_{qij}$  by a dimensionless stress function which would account for any nonlinear stress effects such as

$${}_{kl}D_{qij} f_q(\sigma) \quad (5.12)$$

where  $f(\sigma)$  is a stress dependent function. This type of formulation allows the nonlinear compliance at any stress level to be scaled up or down from the linear compliance. As an example, consider the linear compliance  $D'$  represented by a single Kelvin element

$$D' = D(1 - e^{-t/\lambda}) \quad (5.13)$$

If the nonlinear stress function is assumed to be  $f(\sigma) = (1 + a\sigma^2)$  then the nonlinear compliance would be

$$D'' = D(1 - e^{-t/\lambda}) * (1 + a\sigma^2) \quad (5.14)$$

where  $a$  is a constant and  $\sigma$  is the current stress. If the linear and nonlinear compliance curves are graphed, the scaling factor,  $(1 + a\sigma^2)$ , is quickly identified (see Fig. 5.1). This formulation only works if the nonlinear stress can be described by a vertical shifting of the compliance curves.

Vertical shifting of the basic compliance curve to account for nonlinear stress effects is a common method of modeling nonlinear viscoelastic response [21,22]. Most nonlinear viscoelastic models such as the Schapery, Findley, and other power law based models employ this concept by using nonlinear stress functions. Figure 5.2 shows a simple nonlinear power law with a nonlinear stress function,  $f(\sigma)$ , and how it is scalable. Since this vertical shifting concept works well for power law based models it should also work for a Prony series since, for many cases, the Prony series will just be a fitted equation to a Power law model.

The Prony series can be scaled by just scaling the compliance coefficients,  $D$ , for a particular material

direction by the same amount that the power law would be scaled. Thus all Kelvin elements,  $l$ , will have the same nonlinear scale factor,  $f_q(\sigma_k)$ . However, since the stresses are different in each ply,  $k$ , there will be a different scale factor for each ply.

The nonlinear stress parameter,  $\sigma_k$ , used in the nonlinear stress function can be any function of the matrix or fiber stress states. A common parameter for the transverse and shear nonlinear compliance is the octahedral shear stress in the matrix which is a function of matrix transverse stress,  $\sigma_m$ , and matrix shear stress,  $\sigma_{m12}$ . A more detailed explanation of octahedral shear stress parameter can be found in the report by Dillard, et al [11]. It is sufficient to say at this point that  $\sigma_k$  will be a function of the ply's stress state,  $\sigma_{k1}$ ,  $\sigma_{k2}$ , and  $\sigma_{k3}$  ( $=\sigma_{k12}$ ), regardless of the complexity.

To introduce the nonlinear compliance function into the general formulation, substitute equation 5.12 into equation 5.10 to give

$${}_{kl} \epsilon_{ij}^{t+1} = \frac{h}{(C\lambda_l + h)} \sum_{q=1}^4 \left[ {}_{kl} D_{qij} f_q(\sigma_k^{t+1}) \right] {}_{kl} \sigma_{ij}^{t+1} + \frac{{}_{kl} \epsilon_{ij}^t \lambda_l}{(C\lambda_l + h)} \quad (5.15)$$

Where  $f(\sigma)$  is evaluated at  $t+1$ . Note that  $f(\sigma^{t+1})$  is a function of the future ply stress state,  $\sigma_1^{t+1}$ ,  $\sigma_2^{t+1}$ , and  $\sigma_3^{t+1}$ , all of which are unknown. Thus Eq. 5.15 can be a complex nonlinear function of  $\sigma_j^{t+1}$  which necessitates the need for a numerical solution method. Equation 5.15 can be rewritten as

$${}_{kl} \epsilon_i^{t+1} = \sum_{q=1}^4 \left[ {}_{kl} C_{qij} f_q(\sigma_k^{t+1}) \right] {}_{kl} \sigma_j^{t+1} + {}_{kl} E_{ij}^t \quad (5.16)$$

$$\text{where } {}_{kl}C_{qij} = \frac{h}{(\lambda_l + h)} {}_{kl}D_{qij}$$

$${}_{kl}E_{ij}^t = \frac{{}_{kl}\epsilon_{ij}^t \lambda_l}{(\lambda_l + h)}$$

$${}_k\sigma_j^{t+1} = {}_{kl}\sigma_{ij}^{t+1}$$

The subscript  $l$  has been dropped from  $\sigma$  because the stress is the same for all Kelvin elements in a particular material direction since they are all in series. The subscript  $i$  was also dropped since stress is a vector and not a tensor quantity. Similarly, the subscript  $j$  was dropped from the strain. The dropping of subscripts  $i$  and  $j$  for the stress and strain quantities, respectively, can be understood by reviewing the matrix equations Eq. 5.2 and 5.3.

Substituting equation 5.15 into 5.11 will give the total creep strain for ply,  $k$ , and direction,  $i$ ,

$${}_{kl}\epsilon_i^{t+1} = \sum_{j=1}^3 \sum_{l=1}^n \left\{ \sum_{q=1}^4 \left[ {}_{kl}C_{qij} f_q({}_{kl}\sigma_j^{t+1}) \right] {}_k\sigma_j^{t+1} + {}_{kl}E_{ij}^t \right\} \quad (5.17)$$

For the total strain, the elastic strain also needs to be added to equation 5.14. The elastic strain can be modeled as a nonlinear spring in series with the Prony series for each direction.

$${}_{kl}\epsilon_i^{t+1} = {}_{ko}\epsilon_i^{t+1} = \sum_{q=1}^4 \left[ {}_{ko}D_{qij} g_q({}_{kl}\sigma_j^{t+1}) \right] {}_k\sigma_j^{t+1} \quad (5.18)$$

where  ${}_{ko}D_{qij}$  is the linear compliance of the spring ( $t=0$ ),  $g_q({}_{kl}\sigma_j^{t+1})$  is the nonlinear function of stress for each direction (similar to  $f(\sigma)$ ), and  ${}_{ko}\epsilon_i^{t+1}$  is the elastic nonlinear strain. Adding equation 5.17 and 5.18 gives

$$\begin{aligned}
T_k \epsilon_i^{t+1} &= \sum_{j=1}^3 \sum_{l=1}^n \left[ \left\{ \sum_{q=1}^4 \left( k_{ql}^C C_{qij} f_q^C k \sigma_j^{t+1} \right) k \sigma_j^{t+1} + k_{il}^E E_{ij}^t \right\} \right. \\
&\quad \left. + \sum_{q=1}^4 \left( k_{oq}^D C_{qij} g_q^C k \sigma_j^{t+1} \right) k \sigma_j^{t+1} \right] \\
\text{or} \\
T \epsilon_i^{t+1} &= \sum_{j=1}^3 \sum_{l=1}^n \sum_{q=1}^4 \left( k_{ql}^C C_{qij} f_q^C k \sigma_j^{t+1} \right) k \sigma_j^{t+1} \\
&\quad + \sum_{j=1}^3 \sum_{q=1}^4 \left( k_{oq}^D C_{qij} g_q^C k \sigma_j^{t+1} \right) k \sigma_j^{t+1} + \sum_{j=1}^3 \sum_{l=1}^n \left( k_{il}^E E_{ij}^t \right) \quad (5.19)
\end{aligned}$$

where  $T_k \epsilon_i^{t+1} = T \epsilon_i^{t+1}$  since it is assumed that layers deform equally without debonding or damage. There are a total of  $3k+3$  unknowns,  $T \epsilon_i^{t+1}$  and  $k \sigma_j^{t+1}$ , but there are only  $3k$  equations from Eq. 5.19. The additional 3 equations come from imposing stress equilibrium in each of the 3 stress directions

$${}^o N_j = \sum_{k=1}^m N_j \quad (5.20)$$

where  ${}^o N_j$  is the input load on the laminate and  $N_j$  is the actual load in each layer,  $k$ , when loaded. Equation 5.20 can be rewritten in terms of stress to give

$${}^o \sigma_j = \frac{\sum_{k=1}^3 \left( k \sigma_j^{t+1} k^t \right)}{\sum_{k=1}^3 k^t} \quad (5.21)$$

where  ${}^o \sigma_j$  is the input stress and  $k^t$  is the thickness of each ply. This equation gives the 3 additional equations necessary to solve for the stress and strain unknowns at  $t+1$



time. The equations are nonlinear in terms of stress and are ill conditioned. They can be solved by an iteration technique called the Newton-Raphson Method. Simpler direct methods such as Gauss-Seidel can't be used since the coefficient matrix is not guaranteed to be diagonally positive. The Newton-Raphson takes longer to solve the nonlinear set of equations for each iteration, since the Jacobian matrix must be calculated, but it converges much more rapidly than the other direct iteration methods.

In summary then, the three major problems with the current composite nonlinear viscoelastic analysis programs, nonlinear effects, stability, and orthotropic material, have been solved by using a differential equation formulation based on a series of nonlinear Kelvin elements. Implementation and results of this solutions technique are discussed in the next section.

## 6. VERIFICATION OF THE NONLINEAR DIFFERENTIAL EQUATION METHOD

The method of solution presented in section 5, the nonlinear differential equation method (NDEM), to calculate the nonlinear viscoelastic for orthotropic composite materials needs to be verified by comparing it to exact solution and other solution techniques. The section will present two simple examples, one based on the Kelvin element and the other on the power law, of a multilayered viscoelastic material for both linear and nonlinear cases. The solution will be compared to the exact solution, if obtainable, and other numerical solutions.

The first example is a modified version of the example presented in section 3, that represents a simple one-dimensional two part material; one part is viscoelastic and the other elastic. The elastic material is modeled by a single spring and the viscoelastic material by a spring and a Kelvin element in series, as shown in Fig. 4.1. Since this example is relatively simply and one dimensional, it is possible to find a closed form solution for the linear case. For the nonlinear case, however, a Runge-Kutta method was employed to solve the resulting nonlinear first order differential equation.

The linear case, assuming the applied stress,  $\sigma_0$ , is constant has a closed form solution of

$$\epsilon = \left\{ \frac{1}{E_1 + E_2} - \frac{K_2}{K_1} \right\} \sigma_0 e^{-K_1 t} + \sigma_0 \frac{K_2}{K_1} \quad (6.1)$$

$$\text{Where } K_1 = \frac{E_1 E_2 + E_2 E_3 + E_1 E_3}{\mu(E_1 + E_2)}$$

$$K_2 = \frac{E_2 + E_3}{\mu(E_1 + E_2)}$$

The numerical results of the NDEM technique, both by the Backward Euler Method (BEM) and Backward Trapezoidal Method (BTM), are shown in Fig. 6.2 along with the exact solution and the VISLAP program technique solution. The spring and dashpot constants were assumed to be  $E_1 = E_2 = 1$ ,  $E_3 = 0.11$ ,  $\mu = 1$ , and  $\sigma_0$  is constant, equal to 1, for all solution methods. The second order BTM solution matches the exact results closely whereas the first order VISLAP and BEM solutions are high and low, respectively. This deviation can be accounted for by being only a first order solution technique. It is interesting to point out that the VISLAP solution begins to oscillate and become unstable, as would be expected since it is an explicit solution method whereas the NDEM, for both BEM and BTM, is an implicit method. Also notice that the step size is large, 5 steps per decade, which would be considered the maximum step size but yet the second order NDEM is very accurate.

The same basic model can be used for a nonlinear viscoelastic material by simply changing  $E_3$  and  $\mu$  to include nonlinear stress effects. For the current nonlinear example  $E_3$  and  $\mu$  are as follows

$$E_3 = 0.1 \frac{\sigma_0}{\sigma_2} + 0.1 \quad (6.2)$$

$$\mu = 10 \left\{ 0.1 \frac{\sigma_0}{\sigma_2} + 0.1 \right\} = 10 E_3 \quad (6.3)$$

where  $\sigma_2$  is the stress in material 2 (Fig. 6.1). This type of nonlinearity will cause the material to become stiffer as time progresses since the stress,  $\sigma_2$ , is decreasing in the nonlinear dashpot. As the stress decreases in the Kelvin element, the spring becomes stiffer and can ultimately carry more of the total load. Likewise, the nonlinear dashpot will become more viscous and the viscoelastic response will

be retarded. The other parameters are similar to the linear case,  $E_1 = E_2 = 1$  and  $\sigma_0 = 1$ . The results of both the NDEM and VISLAP techniques are shown in Fig. 6.3 for the nonlinear Kelvin element. To obtain the exact solution one must solve a nonlinear equation of the form

$$\dot{\epsilon} + K_1 \epsilon + K_2 \epsilon^2 + K_3 = 0 \quad (6.4)$$

$$\text{with } \epsilon(0) = c$$

This equation is difficult to solve for a closed form solution but good results can be obtained by using a Runge-Kutta numerical method with small time steps. The results from a Runge-Kutta solution is plotted on Fig. 6.3. For a simple nonlinear example model, like the one being examined, it is possible to use a Runge-Kutta solution as a check which is a well proven and reliable numerical method. For the more general orthotropic problems such a method is not possible as discussed in the proceeding sections.

Similar to the linear case, the first order solution methods, VISLAP and NDEM using BEM, are not as accurate as the second order NDEM using BTM. Also the explicit method, VISLAP, becomes unstable at long time steps.

The second example case is again a two part one-dimensional material with one part viscoelastic and the other elastic. This viscoelastic material is modeled as a power law and a spring in series, and the elastic material as a spring. Figure 6.4 shows the mechanical model describing this test case.

The Power law parameters used are  $m = 0.1$  and  $n = 0.25$  for the linear case and

$$m = 0.1 \frac{\sigma_0}{\sigma_2} + 0.1 \quad (6.5)$$

and  $n = 0.25$  for the nonlinear case. For both the linear and nonlinear case  $E_1 = E_2 = 1.0$ . The results comparing just

the VISLAP and NDEM (BEM and BTM) methods are shown in Figs. 6.5 and 6.6. Both the linear and nonlinear cases show the results for all methods very close, with the BTM between the other two methods. This is similar to the results of the linear and nonlinear Kelvin cases discussed earlier. There is no exact solution available to compare results and the resulting equation can't be solved by the Runge-Kutta in a convenient manner. However the results of both the VISLAP and NDEM techniques are similar, giving some reassurance that the answer is correct.

In summary, the nonlinear differential equation method (NDEM) in solving nonlinear viscoelastic problems that involve multiple material layers has been shown to be an accurate method and does converge to the correct answer. The two test cases examined, Kelvin and Power law models, showed the NDEM results match the exact solution and/or other numerical methods. The second order BTM technique proved to be the most accurate and was stable for all time steps.

## 7. SUMMARY AND CONCLUSIONS

This report has looked at various methods to solve nonlinear viscoelastic problems that deal with orthotropic materials such as fiber reinforced composites. Earlier methods, such as the VISLAP computer program algorithm, was examined and some of the deficiencies discussed. The main three problems of these methods were 1), stability of the solution technique, 2), time step size stability, and 3), solution time length and computer memory storage. Two other methods were examined in detail, Volterra Integral and the Zienkiewicz method, plus a new method, the Nonlinear Differential Equation Method (NDEM) was developed to try to overcome some of the deficiencies.

The Volterra Integral allowed the implementation of higher order solution techniques but it had difficulties on solving singular and weakly singular compliance functions. The power law compliance function, which is weakly singular, was solvable only with very small time steps. This method also needs an ever increasing amount of computer time as the solution process goes further out in time, similar to the VISLAP method. This was due to the hereditary type integral solution process which must recalculate the total integral for each addition time step. This method was found to be unacceptable for reasons of computer time needed and accuracy.

The second method examined was the Zienkiewicz solution technique which requires the viscoelastic response to be modeled by a Prony series. This method works well for linear viscoelastic isotropic materials and small time steps. The biggest advantage of this technique is that the solution algorithm can be written in a recursive fashion which does not require the recalculation of the past results like the VISLAP and Volterra Integral methods. This allows

the solution at long times to be done efficiently and quickly. The biggest problem with this method is the limit on time step size since the method uses an explicit solution technique. Thus the solution can become unstable and diverge from the correct answer.

To overcome the above deficiencies a new method, NDEM, was developed. This method requires the viscoelastic response be described by a modified Prony series which allows nonlinear stress effects to be included. The differential equations that model each of the Kelvin elements in the Prony series, are then solved simultaneously. By using the basic differential equations, an implicit solution method can be used. This causes the solution process to be unconditionally stable for any time step. The general method of solving the nonlinear simultaneous equation used was the Newton-Raphson method which assures convergence even if the coefficient matrix of the equations is not positive definite. In addition to overcoming the numerical problems this method was extended to include orthotropic nonlinear viscoelastic materials.

The NDEM technique was shown to be accurate and stable on two test cases, Kelvin and Power law based, for both linear and nonlinear conditions. The advantages of NDEM is that it is stable for all time step sizes, the solution algorithm is stable and converges to the correct solution, and the computer time is minimized.

## APPENDIX A - BACKWARD TRAPEZOIDAL METHOD

In Chapter 5 the Backward Euler Method was used in solving the nonlinear viscoelastic problem of orthotropic composite laminates and a detail derivation was given. The Backward Trapezoidal Method (BTM) will be briefly developed in this appendix.

Recall the basic differential equation, Eq. 5.8, of a single Kelvin element

$$\dot{\epsilon}_{ij}^{kl} = \sum_{q=1}^4 \left[ \frac{k_{qij}^D}{\lambda_l} \right] \sigma_{ij}^{kl} - \frac{\epsilon_{ij}^{kl}}{\lambda_l} \quad (\text{A.1})$$

where  $\dot{\epsilon}_{ij}^{kl}$  and  $\epsilon_{ij}^{kl}$  are the strain rate and strain, respectively,  $\sigma_{ij}^{kl}$  is the stress in each Kelvin element,  $l$ , ply,  $k$ , compliance direction,  $q$ , and rotated position,  $(i,j)$ . Using the BTM the numerical approximation becomes

$$\frac{\epsilon_{ij}^{kl,t+1} - \epsilon_{ij}^{kl,t}}{\Delta t} = \frac{1}{2} \left\{ \sum_{q=1}^4 \left[ \frac{k_{qij}^D}{\lambda_l} \right] \sigma_{ij}^{kl,t+1} - \frac{\epsilon_{ij}^{kl,t+1}}{\lambda_l} + \sum_{q=1}^4 \left[ \frac{k_{qij}^D}{\lambda_l} \right] \sigma_{ij}^{kl,t} - \frac{\epsilon_{ij}^{kl,t}}{\lambda_l} \right\} \quad (\text{A.2})$$

where  $\Delta t$  is the time step size,  $t+1$  is the new time and  $t$  is the old time. This can be rewritten as

$$\epsilon_{ij}^{kl,t+1} = \frac{h}{2\lambda_l + h} \sum_{q=1}^4 k_{qij}^D \sigma_{ij}^{kl,t+1} + \frac{h}{2\lambda_l + h} \sum_{q=1}^4 k_{qij}^D \sigma_{ij}^{kl,t} + \frac{2\lambda_l - h}{2\lambda_l + h} \epsilon_{ij}^{kl,t} \quad (\text{A.3})$$

where  $h = \Delta t$ . When the nonlinear stress function are



included (Eq 5.10) Eq A.3 becomes

$$\begin{aligned}
 {}_{kl}e_{ij}^{t+1} &= \frac{h}{2\lambda_l+h} \sum_{q=1}^4 {}_{kl}D_{qij} {}_{kl}\sigma_{ij}^{t+1} f_q({}_{kl}\sigma^{t+1}) + \\
 &+ \frac{h}{2\lambda_l+h} \sum_{q=1}^4 {}_{kl}D_{qij} {}_{kl}\sigma_{ij}^t f_q({}_{kl}\sigma^t) + \frac{2\lambda_l-h}{2\lambda_l+h} {}_{kl}e_{ij}^t \quad (A.4)
 \end{aligned}$$

This can be further simplified as

$${}_{kl}e_i^{t+1} = \sum_{q=1}^4 \left[ {}_{kl}C_{qij} f_q({}_{kl}\sigma^{t+1}) \right] {}_{kl}\sigma_j^{t+1} + {}_{kl}E_{ij}^t \quad (A.5)$$

$$\text{where } {}_{kl}E_{ij}^t = \sum_{q=1}^4 \left[ {}_{kl}C_{qij} f_q({}_{kl}\sigma^t) \right] {}_{kl}\sigma_j^t + \frac{2\lambda_l-h}{2\lambda_l+h} {}_{kl}e_{ij}^t$$

$${}_{kl}C_{qij} = \frac{h}{(2\lambda_l+h)} {}_{kl}D_{qij}$$

$${}_{kl}\sigma_j^{t+1} = {}_{kl}\sigma_{ij}^{t+1}$$

Summing all the creep strains together for each element in the series of Kelvin element will give, similar to BEM,

$${}_{kl}e_i^{t+1} = \sum_{j=1}^3 \sum_{l=1}^n \left\{ \sum_{q=1}^4 \left[ {}_{kl}C_{qij} f_q({}_{kl}\sigma^{t+1}) \right] {}_{kl}\sigma_j^{t+1} + {}_{kl}E_{ij}^t \right\} \quad (A.6)$$

From this point the derivation is the same as the BEM. As with the BEM, the BTM is unconditionally stable for all time steps. It is a second order method which will be more accurate than the BEM.

## References

1. Dillard, D.A., D.H. Morris and H.F. Brinson, "Creep and Creep Rupture of Laminated Graphite/Epoxy Composites," Virginia Polytechnic Institute and State University, VPI-E-81-3, Blacksburg, Va, February 1981.
2. Dillard, D.A. and H.F. Brinson, "A Numerical Procedure for Predicting Creep and Delayed Failures in Laminated Composites," Long Term Behavior of Composites, ASTM 813, T.K. O'Brain (Ed.), 1983, pp. 23-37.
3. Tuttle, M.E. and H.F. Brinson, "Accelerated Viscoelastic Characterization of T300/5208 Graphite/Epoxy Laminates," NASA Contractor Report 3871, March 1985.
4. Hiel, C., A.H. Cardon and H.F. Brinson, "The Nonlinear Viscoelastic Response of Resin Matrix Composite Laminates," NASA Contractor Report 3772, July 1984.
5. Carnahan, B., H.A. Luther, and J.O. Wilkes, Applied Numerical Methods, John Wiley, New York, 1969.
6. Boyce, W. and R.C. DiPrima, Elementary Differential Equations and Boundary Value Problems, John Wiley, Third Edition, New York, 1977.
7. Flugge, W., Viscoelasticity, Second Edition, Springer-Verlag, New York, 1975.
8. Delves, L.M. and J.L. Mohamed, J.L., Computational Methods for Integral Equations, Cambridge University Press, Cambridge, 1985.
9. Hochstadt, H., Integral Equations, John Wiley, New York, 1973.
11. Day, J.T., "A Starting Method for solving Nonlinear Volterra Integral Equations," Math. of Computation, Vol. 21, No. 98, 1967, pp. 179-188.
12. Day, J.T., "Numerical Solution of the Convolution Integral Equation," BIT, Vol. 9, 1969, pp. 81-82.
13. Cameron, R.F., and S. McKee, "The Direct Numerical Solution of a Volterra Integral Equation Arising out of Viscoelastic Stress in Materials," Computer Methods in Applied Mechanics and Engineering, Vol. 29, 1981, pp. 219-232.

14. Jones, J.G., "On the Numerical Solution of Convolution Integral Equations and Systems of such Equations," Math. of Computation, Vol. 15, 1961, pp. 131-142.
15. Zienkiewicz, O.C., M. Watson and I.P. King, "A Numerical Method of Viscoelastic Stress Analysis," Int. J. Mech. Sci., Vol. 10, 1968, pp. 807-827.
16. Zienkiewicz, O.C., The Finite Element Method, McGraw-Hill, London, 1977.
17. Henriksen, M., "Nonlinear Viscoelastic Stress Analysis, A Finite Element Approach," Computers and Structures, Vol. 18, No. 1, 1984, pp. 133-139.
18. Booker, J.R. and J.C. Small, "An Investigation of the Stability of Numerical Solutions of the Equations of Viscoelasticity," International Journal for Numerical Methods in Engineering, Vol. 11, 1977, pp. 1819-1830.
19. Jones, R.M., Mechanics of Composite Materials, McGraw-Hill, New York, 1975.
20. Tsai, S.W. and H.T. Hahn, Introduction to Composite Materials, Technomic, Westport, Connecticut, 1980.
21. Findley, W.N., J.S. Lai and K. Onaran, Creep and Relaxation of Nonlinear Viscoelastic Materials, North-Holland Publishing Company Amsterdam, New York, 1972.
22. Schapery, R.A., "Viscoelastic Behavior and Analysis of Composite Materials," Composite Materials, G.P. Sendeckyj (Ed.), Chapter 4, Vol. 2, Academic Press, p. 85, 1974

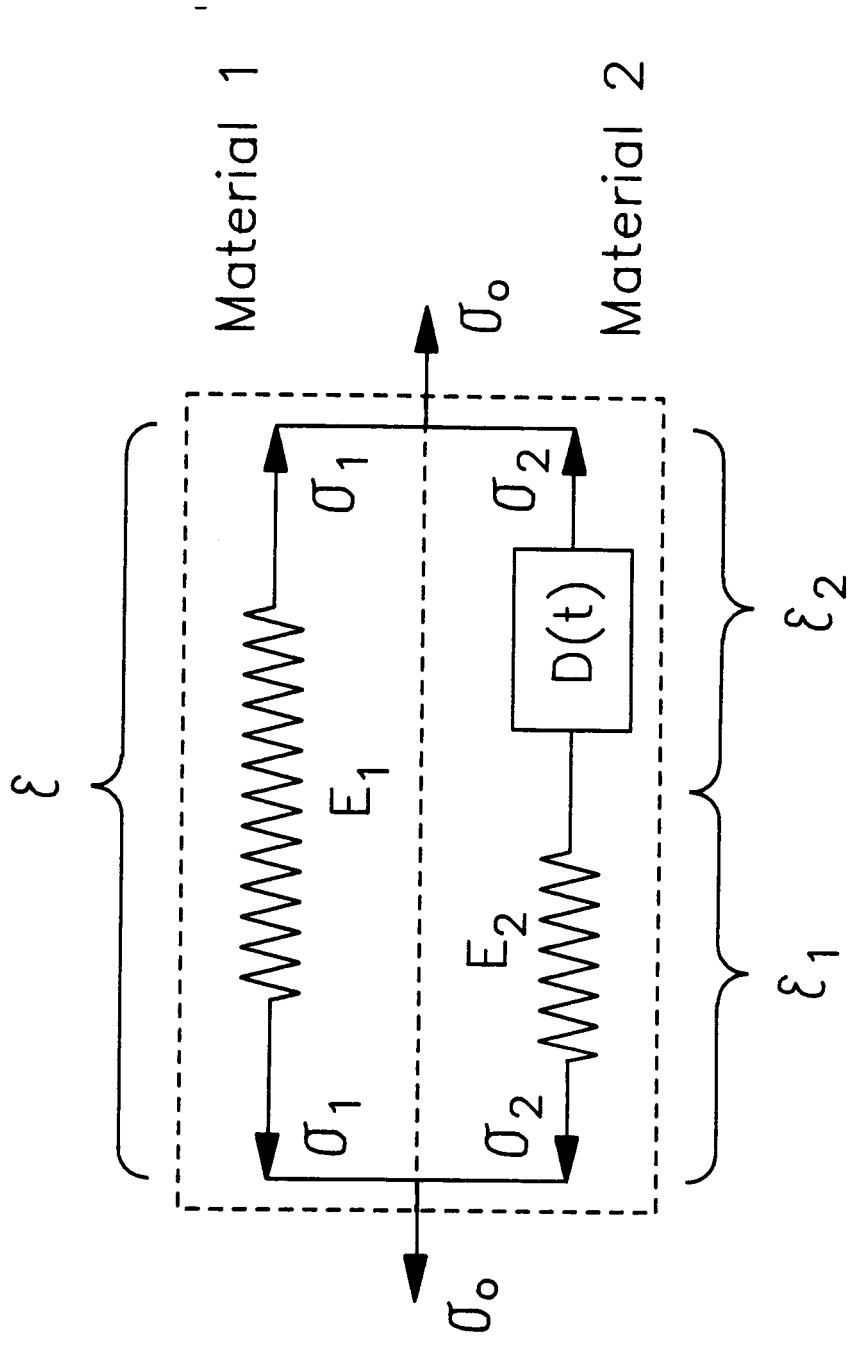

Figure 3.1 Two Part Viscoelastic Material Model

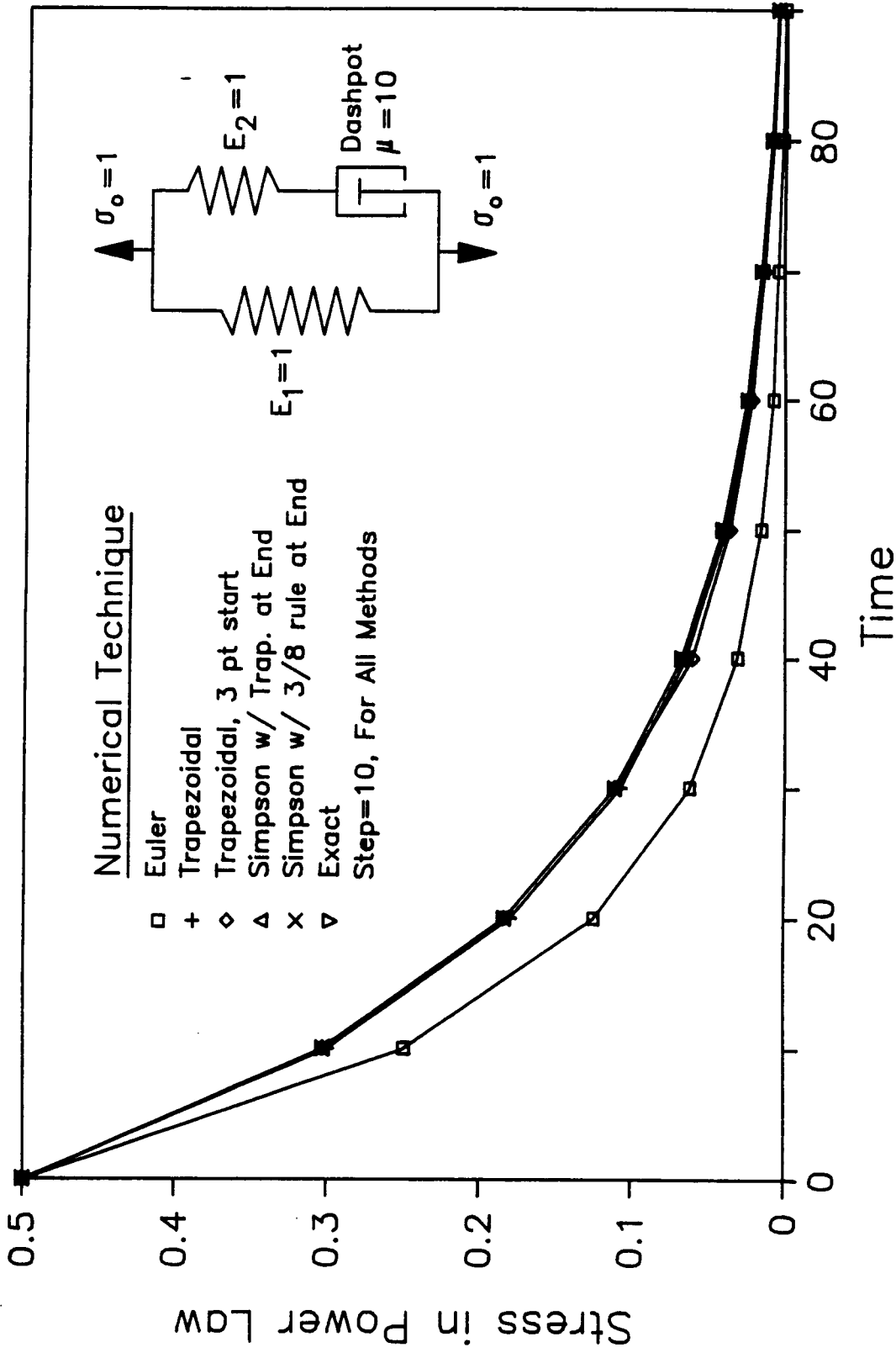

Figure 3.2 Numerical Solutions of a 3 Parameter Dashpot Model Using the Volterra Integral

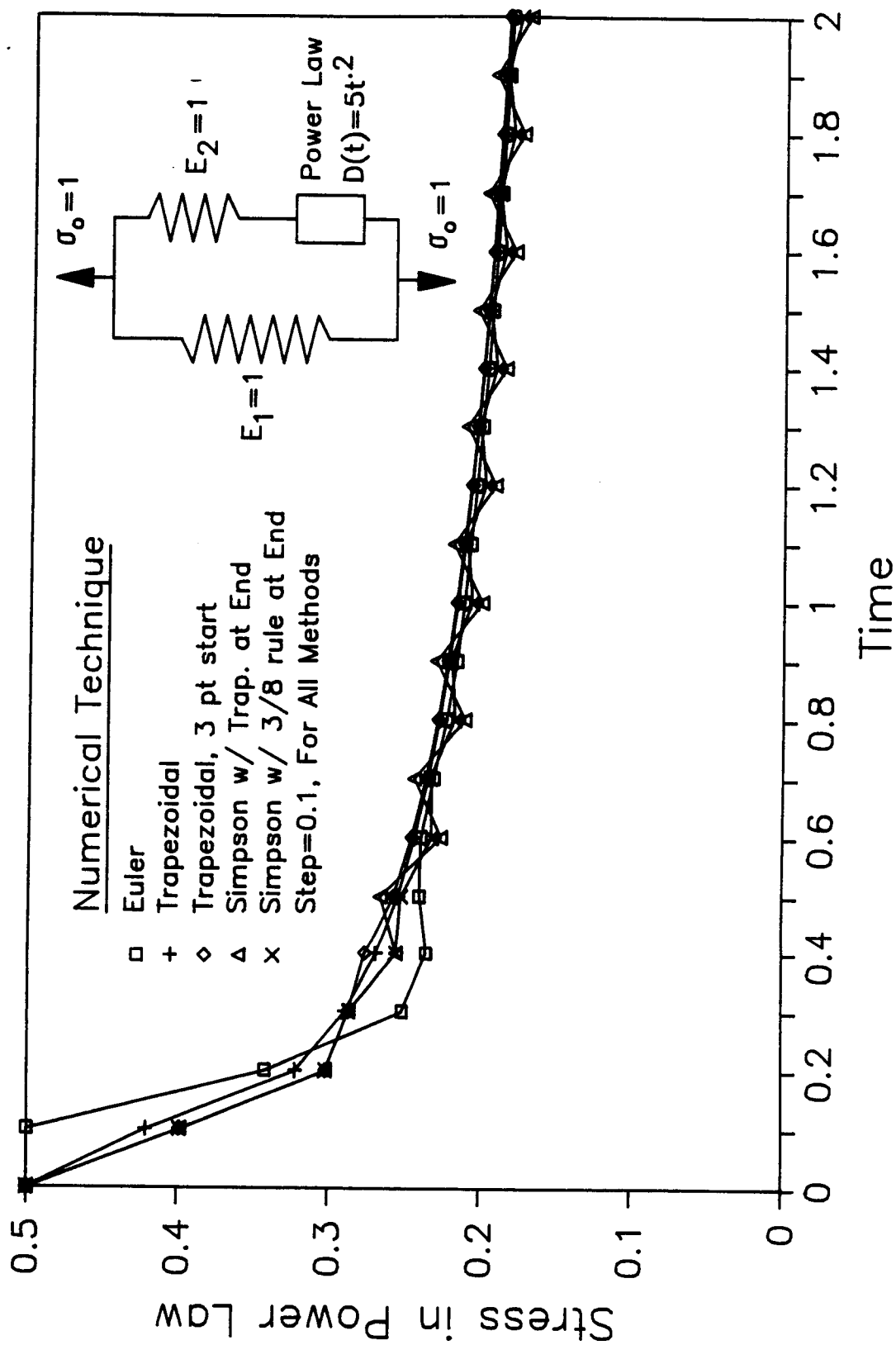

Figure 3.3 Numerical Solutions of a 3 Parameter Power Law Model Using the Volterra Integral

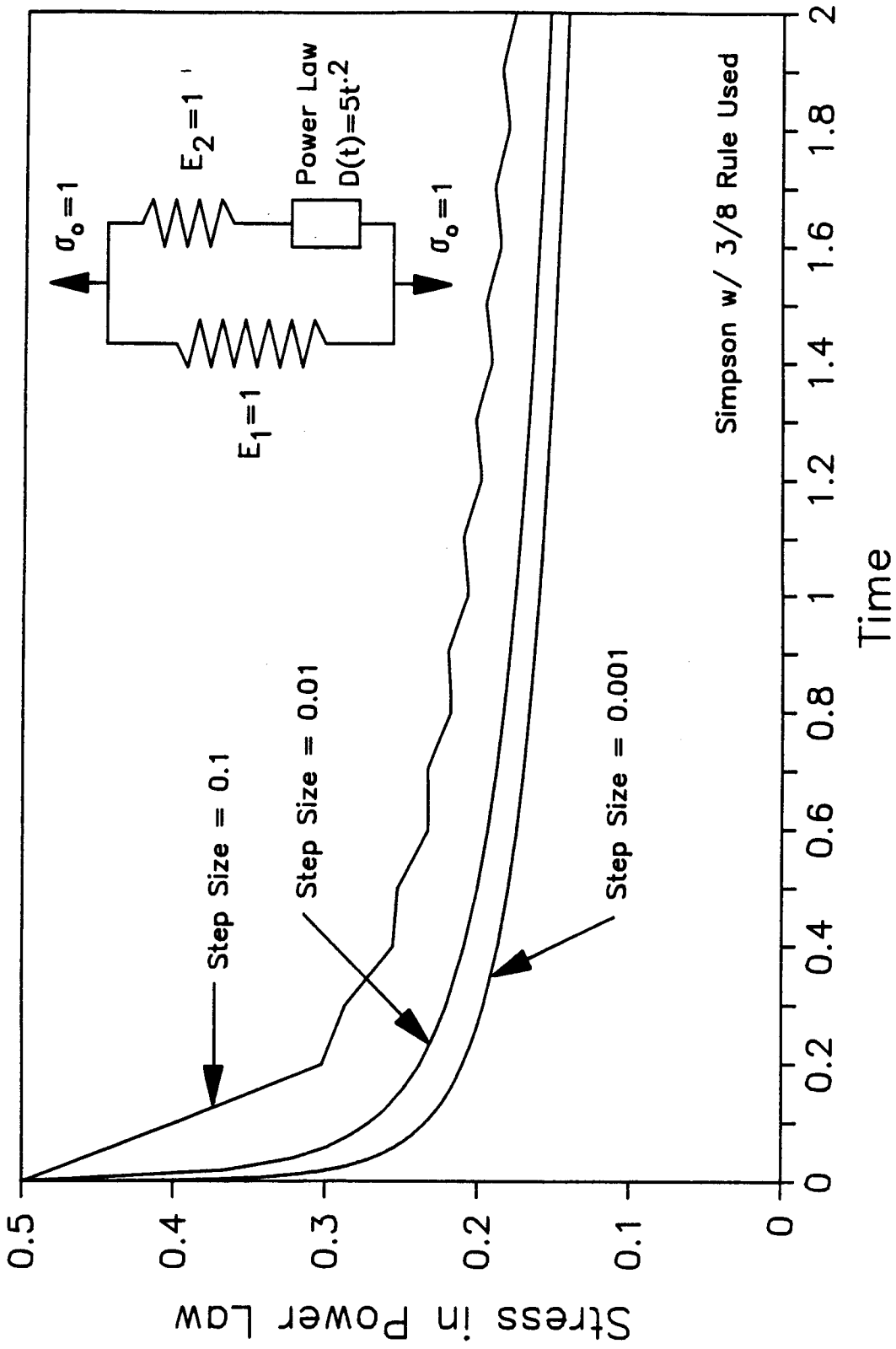

Figure 3.4 Numerical Solutions of the Volterra Integral Using the Simpson Rule with the 3/8 Rule

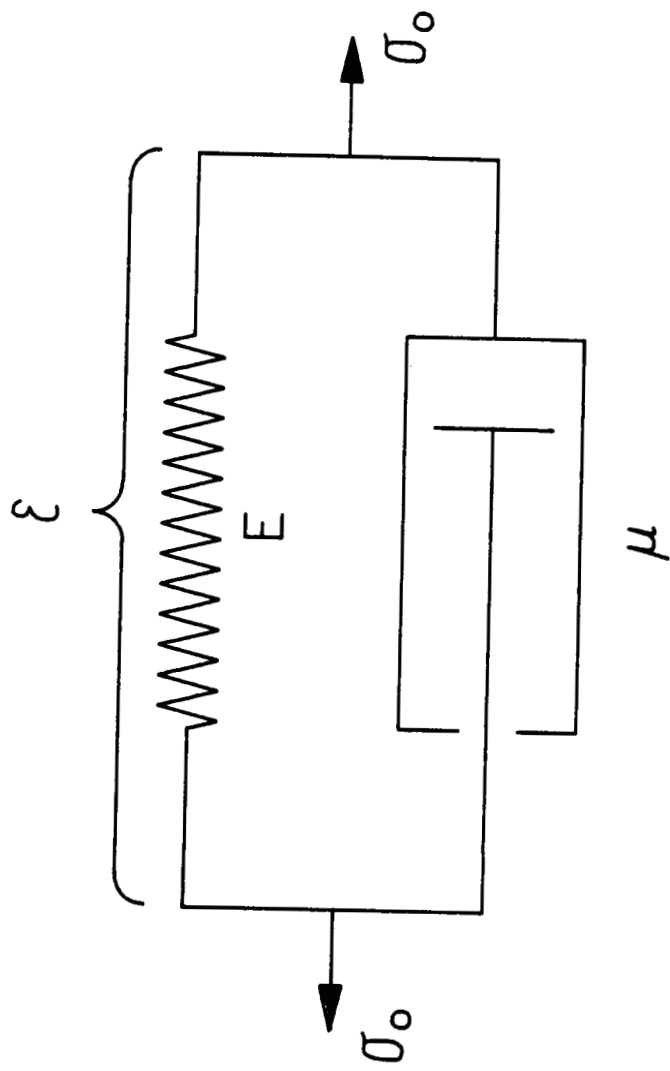

Figure 4.1 Kelvin Element



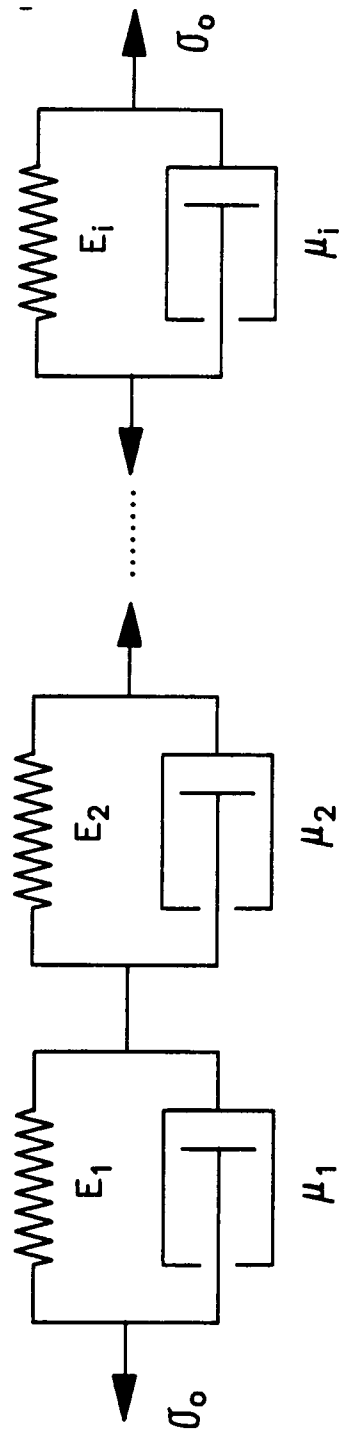

Figure 4.2 Kelvin Elements in Series

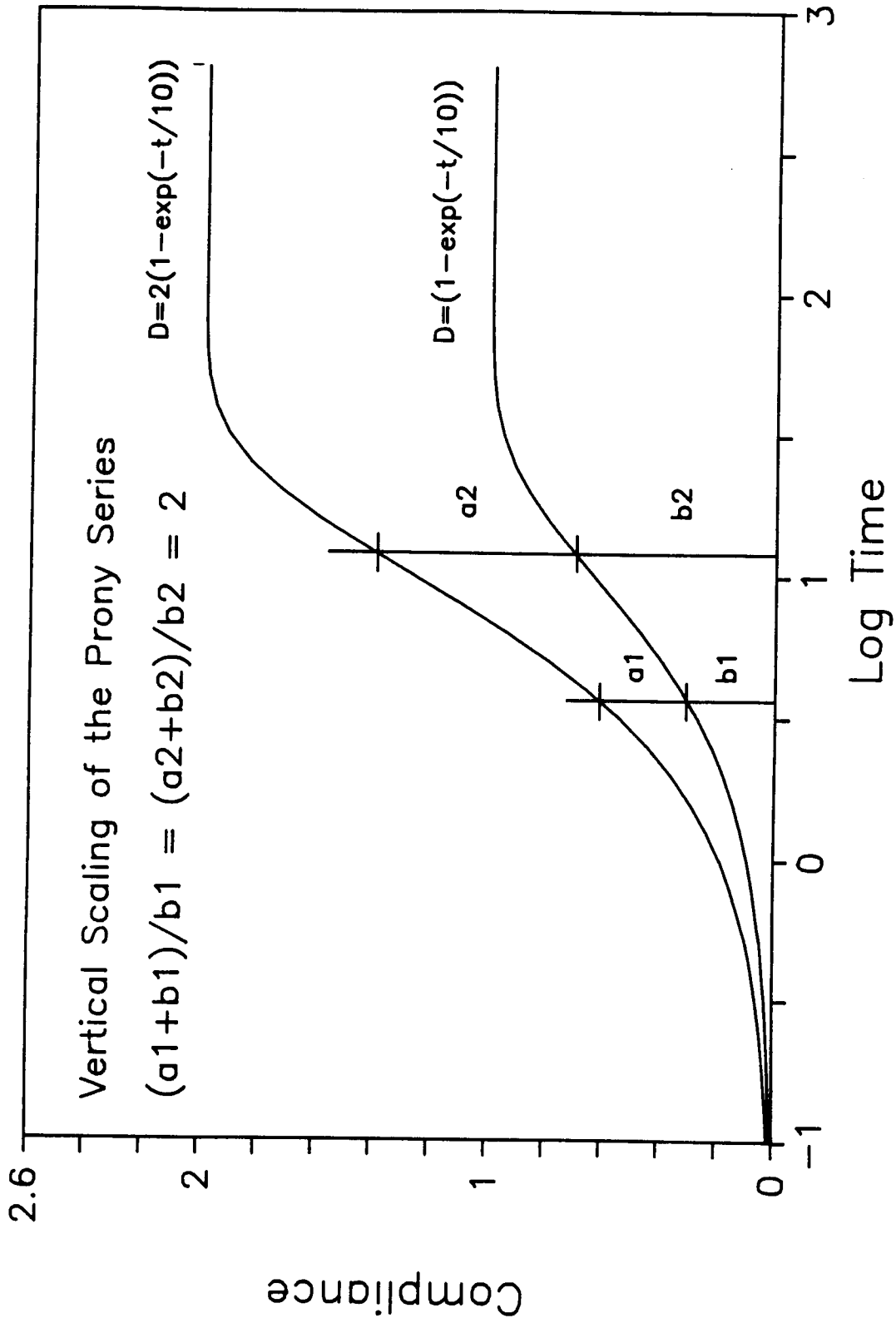

Figure 5.1 Vertical Scaling of a Single Kelvin Element

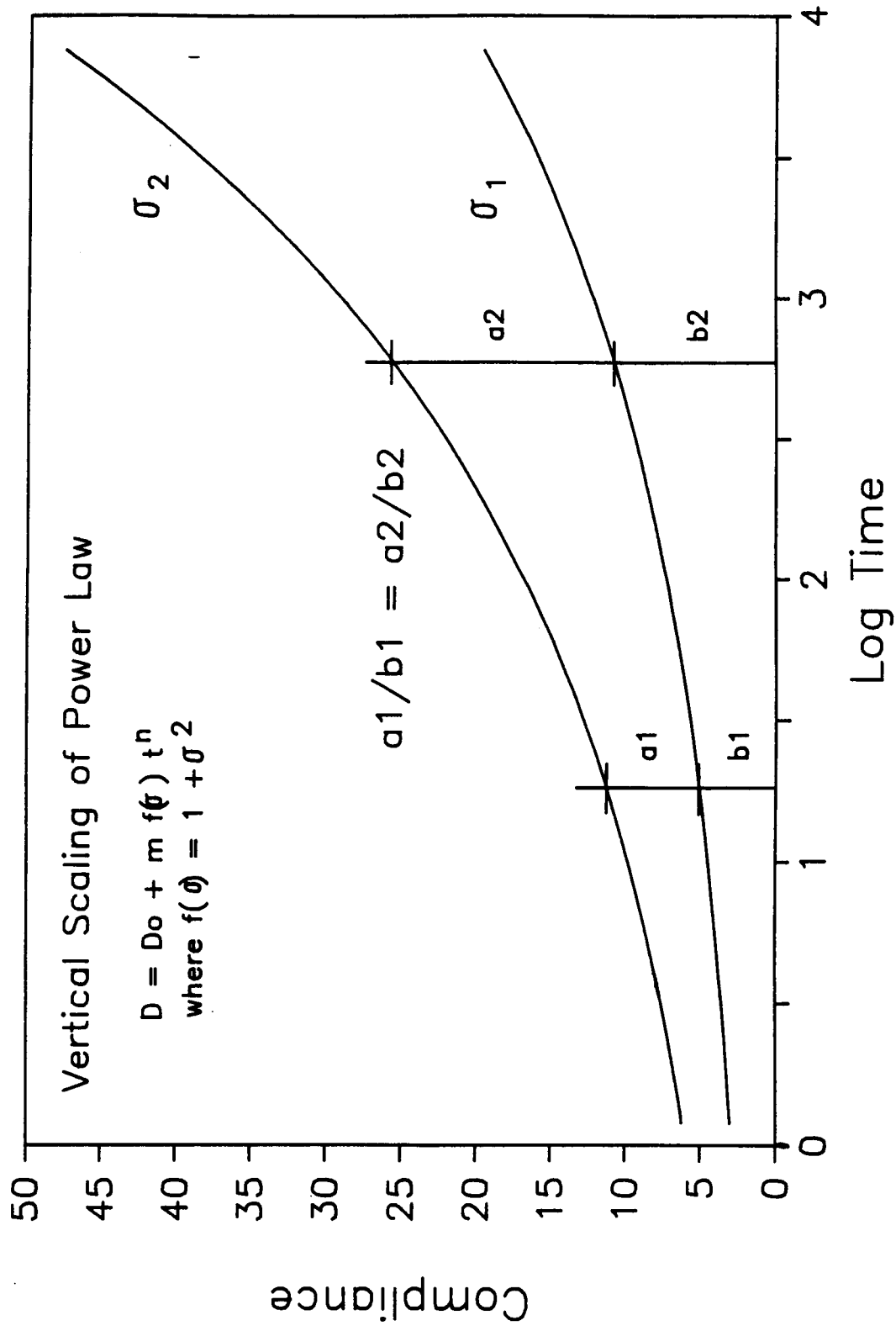

Figure 5.2 Vertical Scaling of a Power Law Compliance Function

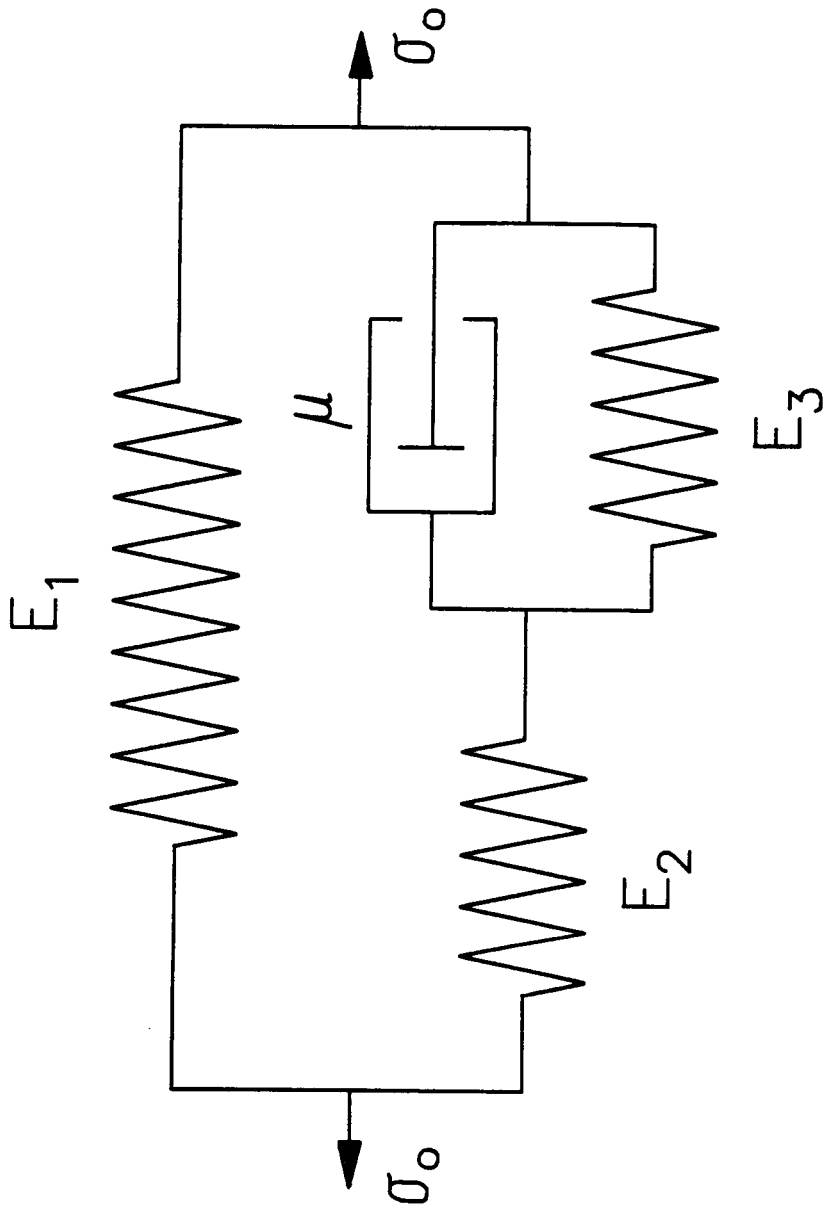

Figure 6.1 Kelvin Element Test Model

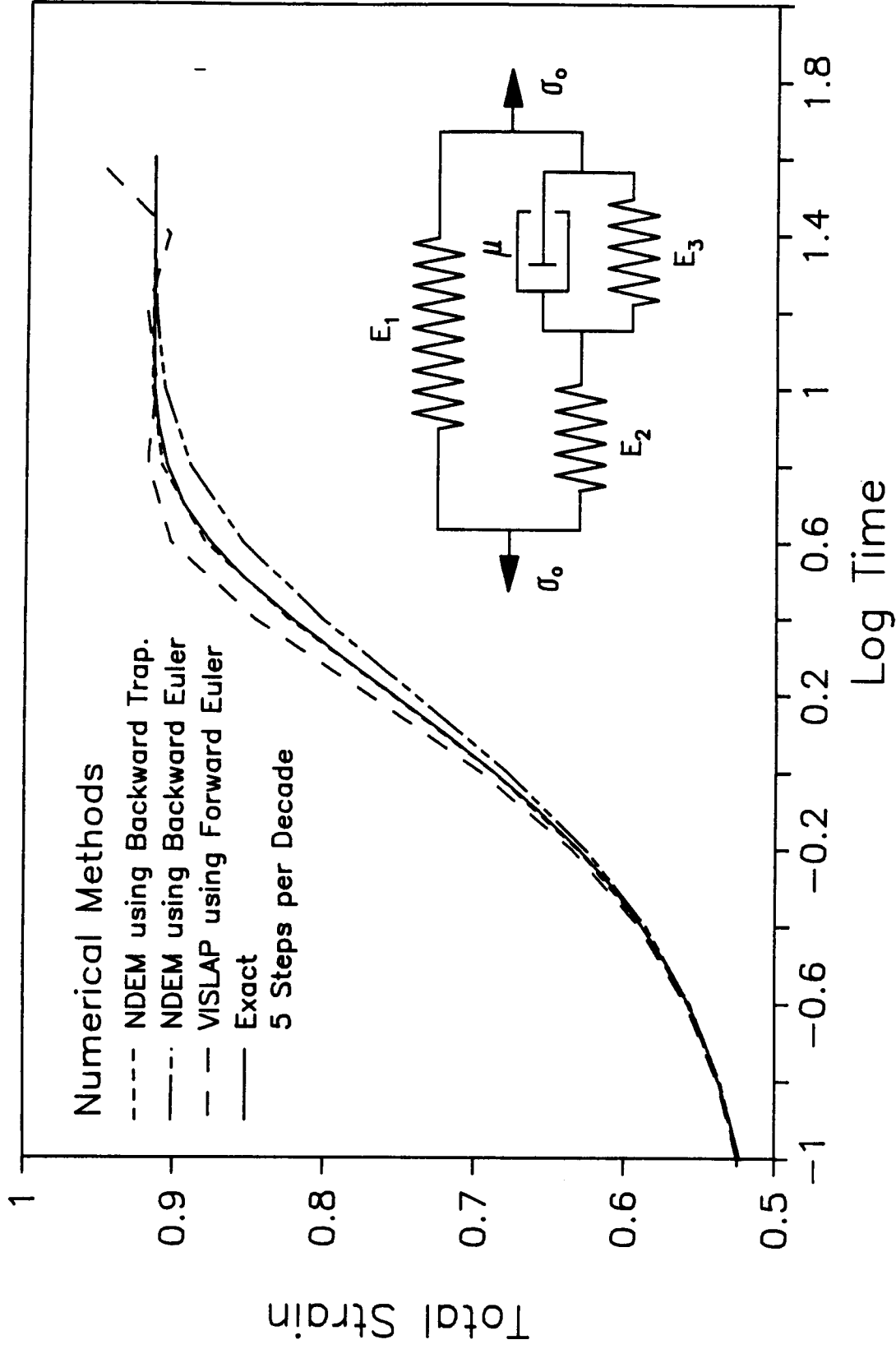

Figure 6.2 Results of Various Numerical Techniques for the Linear Kelvin Element Test Case

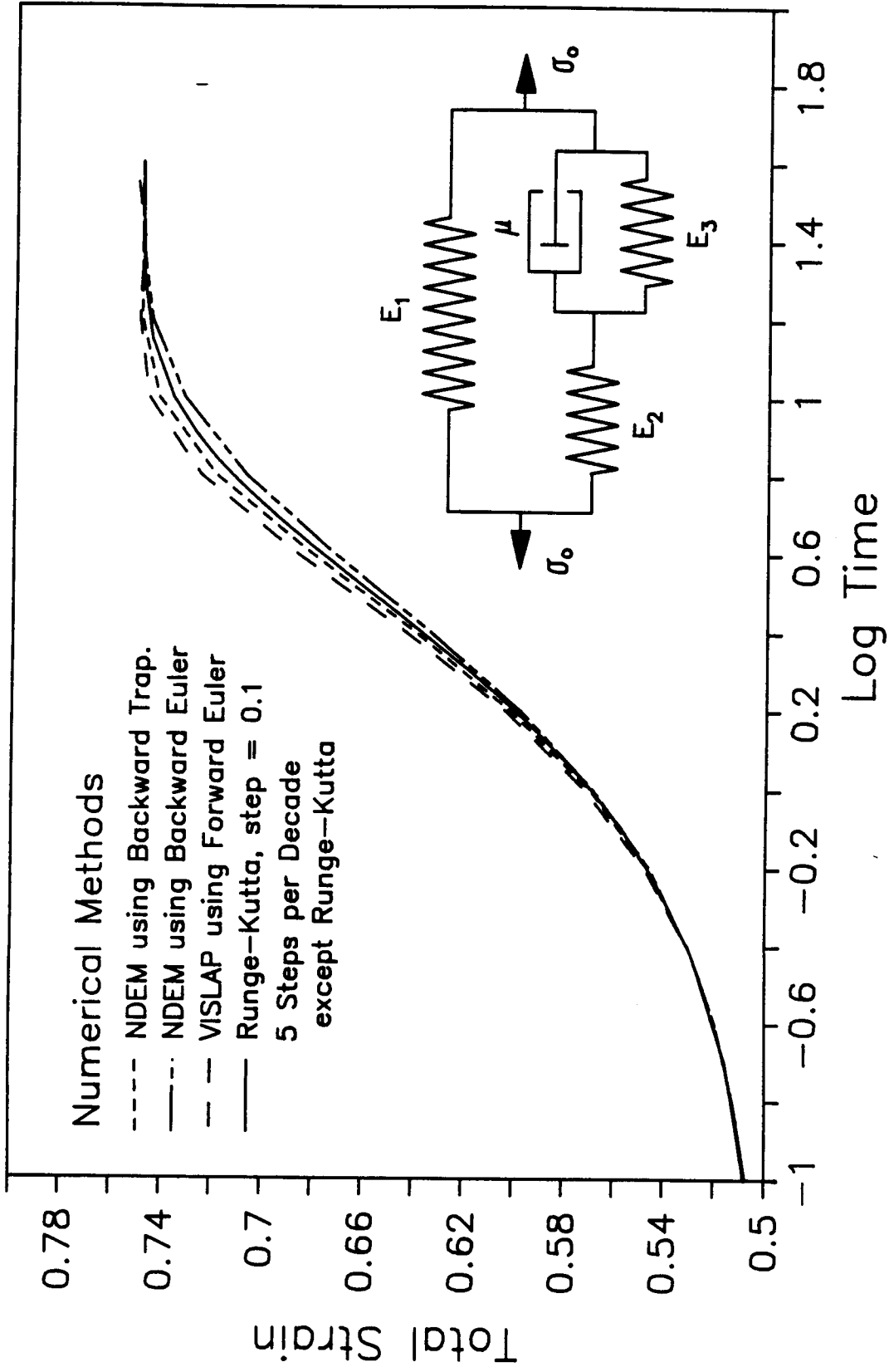

Figure 6.3 Results of Various Numerical Techniques for the Nonlinear Kelvin Element Test Case

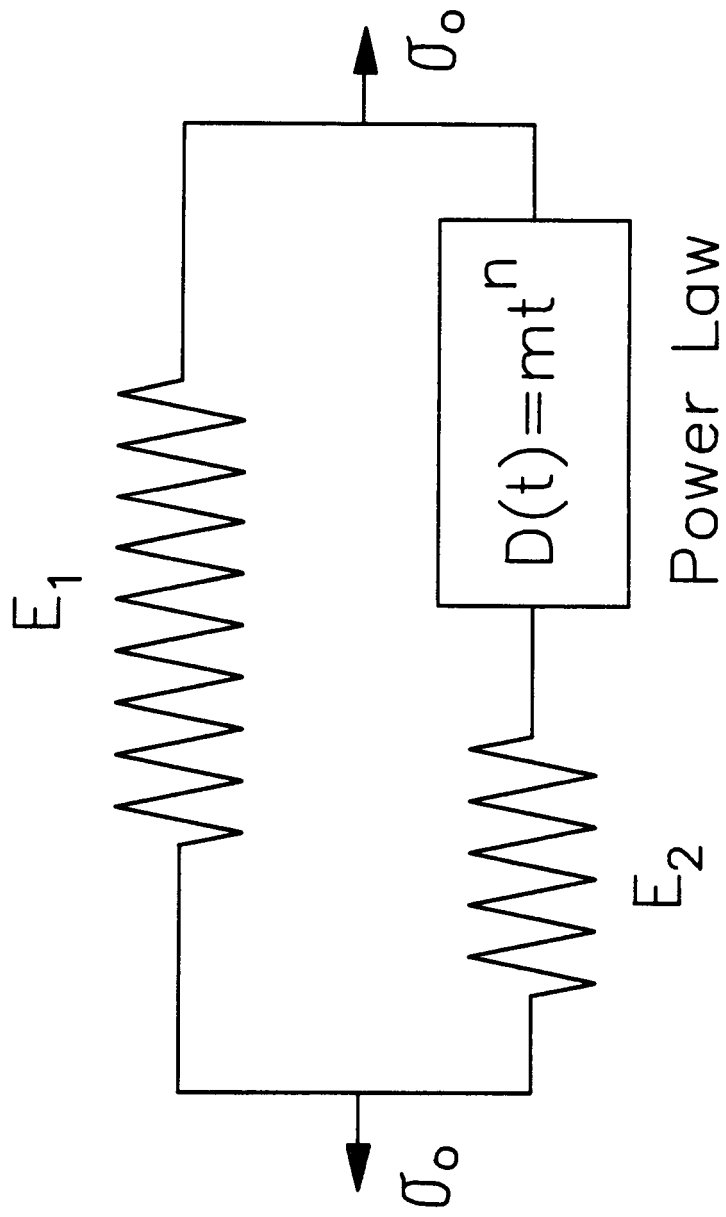

Figure 6.4 Power Law Test Model

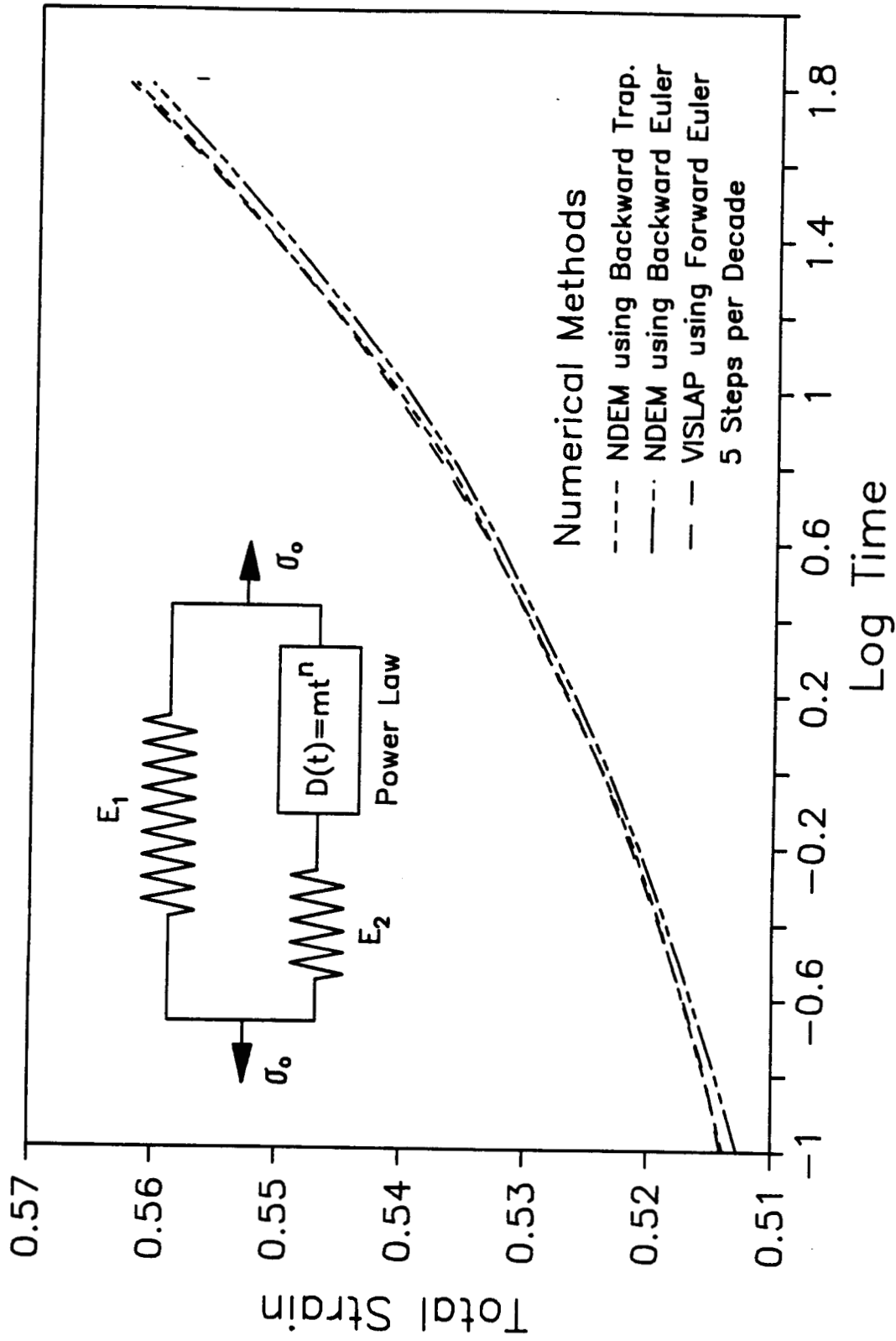

Figure 6.5 Results of Various Numerical Techniques for the Linear Power Law Test Case



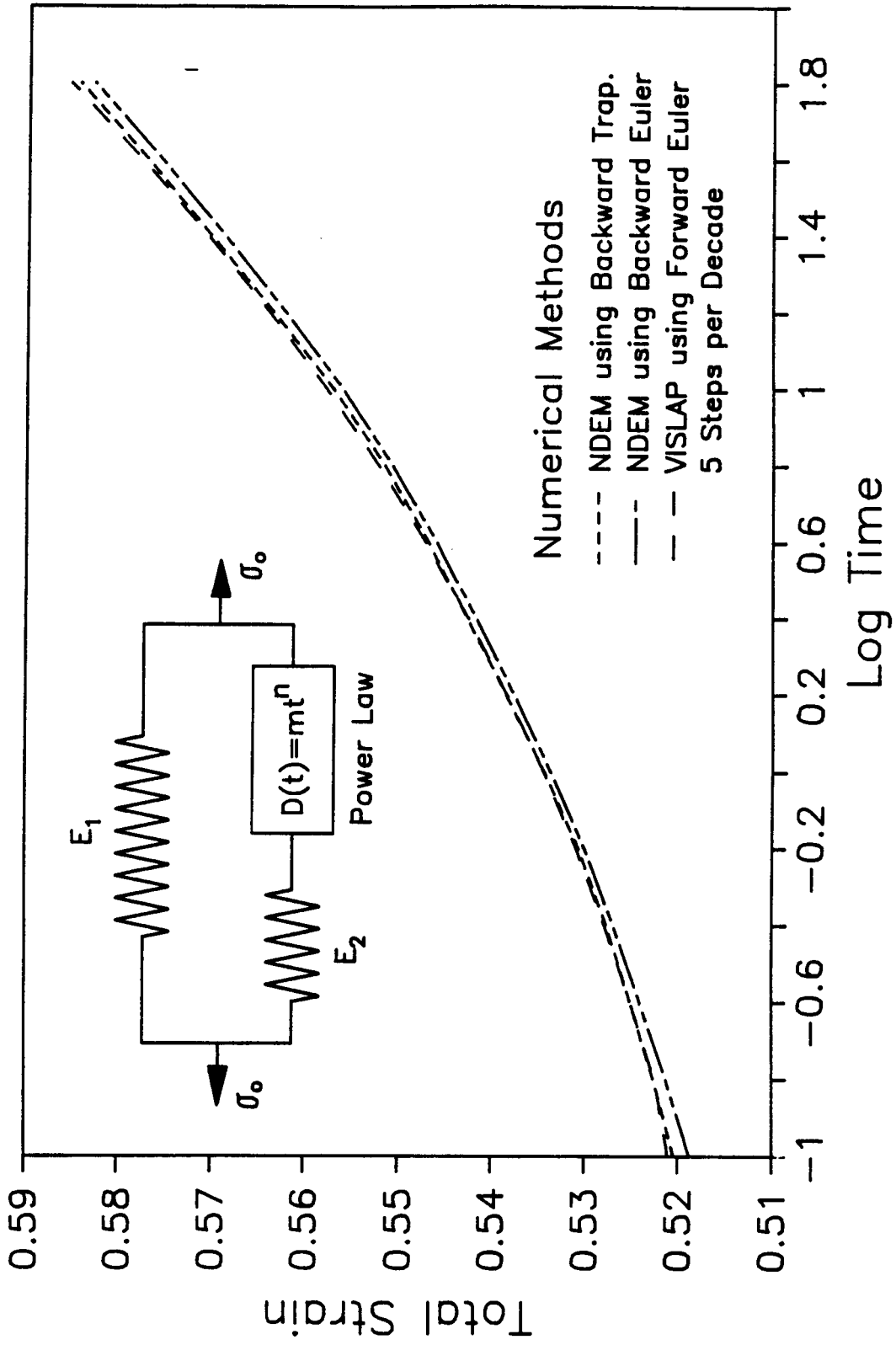

Figure 6.6. Results of Various Numerical Techniques for the Nonlinear Power Law Test Case

<b>BIBLIOGRAPHIC DATA SHEET</b>		1. Report No.	2.	3. Recipient's Accession No.
4. Title and Subtitle Numerical Solution Methods for Viscoelastic Orthotropic Materials			5. Report Date January 1988	
7. Author(s) K. C. Gramoll, D. A. Dillard and H. F. Brinson			8. Performing Organization Rept. No. VPI-E-88-1 CAS/ESM-88-1	
9. Performing Organization Name and Address Virginia Polytechnic Institute and State University Center for Adhesion Science and Department of Engineering Science and Mechanics Blacksburg, VA 24061			10. Project/Task/Work Unit No.	
12. Sponsoring Organization Name and Address NASA-Ames Research Center Test Engineering & Analysis Branch Mail Stop 213-3 Moffett Field, CA 94035			11. Contract/Grant No. NCC 2-71	
			13. Type of Report & Period Covered Semi-annual 7/87 - 12/87	
15. Supplementary Notes				
16. Abstracts <p>Numerical solution methods for viscoelastic orthotropic materials, specifically fiber reinforced composite materials, are examined. The methods included, classical lamination theory using time increments, direction solution of the Volterra Integral, Zienkiewicz's linear Prony series method, and a new method called Nonlinear Differential Equation Method (NDEM) which uses a nonlinear Prony series. The criteria used for comparison of the various methods include the stability of the solution technique, time step size stability, computer solution time length, and computer memory storage.</p> <p>The Volterra Integral allowed the implementation of higher order solution techniques but it had difficulties on solving singular and weakly singular compliance function. The Zienkiewicz solution technique, which requires the viscoelastic response to be modeled by a Prony series, works well for linear viscoelastic isotropic materials and small time steps. The new method, NDEM, uses a modified Prony series which allows nonlinear stress effects to be included and can be used with orthotropic</p>				
17. Key Words and Document Analysis. 17a. Descriptors (see next page)				
17b. Identifiers/Open-Ended Terms				
17c. COSATI Field/Group				
18. Availability Statement Unlimited			19. Security Class (This Report) UNCLASSIFIED	21. No. of Pages 56
			20. Security Class (This Page) UNCLASSIFIED	22. Price

16. Abstract continued

nonlinear viscoelastic materials. The NDEM technique is shown to be accurate and stable for both linear and nonlinear conditions, and the computer solution time is minimal. Numerical examples and test cases are used to compare each solution method.