

# NASA Contractor Report 3922(16)

## USSR Space Life Sciences Digest

*Issue 14*

*Edited by*

Lydia Razran Hooke and Ronald Teeter

*Lockheed Engineering and Management Services Co.  
Washington, D.C.*

Mike Radtke

*RCA Government Services  
Washington, D.C.*

*RR 77422*

Joseph Rowe

*Library of Congress  
Washington, D.C.*

*LN 718877*

Prepared for

NASA Office of Space Science and Applications  
under Contract NASW-4292



National Aeronautics  
and Space Administration

Scientific and Technical  
Information Division

1988

## CONTENTS

Reader Feedback Form .....	v
FROM THE EDITORS .....	vi
ADAPTATION .....	1
BIOLOGICAL RHYTHMS* .....	5
BODY FLUIDS .....	5
BOTANY .....	7
CARDIOVASCULAR AND RESPIRATORY SYSTEMS.....	10
COSMONAUT TRAINING .....	28
DEVELOPMENTAL BIOLOGY .....	30
ENDOCRINOLOGY .....	33
ENZYMOLOGY .....	36
EQUIPMENT AND INSTRUMENTATION*.....	38
GASTROINTESTINAL SYSTEM .....	38
HABITABILITY AND ENVIRONMENTAL EFFECTS .....	39
HUMAN PERFORMANCE*.....	41
IMMUNOLOGY .....	41
LIFE SUPPORT SYSTEMS .....	47
MATHEMATICAL MODELING* .....	51
METABOLISM .....	53
MUSCULOSKELETAL SYSTEM .....	56
NEUROPHYSIOLOGY .....	58
NUTRITION* .....	60

\* Topics marked with \* have no entries of their own, but refer readers to relevant abstracts included in other topic areas.

PRECEDING PAGE BLANK NOT FILMED

OPERATIONAL MEDICINE* .....	60
PERCEPTION .....	60
PERSONNEL SELECTION* .....	61
PSYCHOLOGY* .....	61
RADIOBIOLOGY .....	61
SPACE BIOLOGY AND MEDICINE .....	70
SPECIAL FEATURE: CHEMICAL NAMES OF SOVIET DRUGS REFERRED TO IN DIGEST ISSUES 1-13 .....	100
CURRENT TRANSLATED SOVIET LIFE SCIENCES MATERIALS .....	102

USSR Space Life Sciences Digest: Number 10 Reader Feedback Form

To our readers: We are working in a large number of highly technical, specialized areas for which adequate Russian-English glossaries have yet to be compiled. We ask your help in improving the accuracy and specificity of our English terminology. Please fill out the form below whenever you encounter an incomprehensible, incongruous, awkward or otherwise inappropriate term. While we solicit all suggestions for improved renderings, the statement that a term is inappropriate provides us with useful information, even when no better alternative can be suggested. A copy of this form will appear in all future issues of the Digest. Thank you for your help.

Abstract #	Incorrect or contextually inappropriate word or phrase:	Suggested rendering: ("??" is an acceptable entry)
------------	---	--

--	--	--

PLEASE RETURN TO: Dr. Lydia Hooke  
Lockheed Engineering  
and Management Services Company  
600 Maryland Ave. SW  
Suite 600, East Wing  
Washington, DC 20024

## FROM THE EDITORS

The fourteenth issue of the USSR Space Life Sciences Digest is the first issue to be produced under contract between NASA's Life Sciences Division and Lockheed Engineering and Management Services Company. We would especially like to thank Dr. Mike Radtke for his excellent technical editing, a service he performed for this issue on a voluntary basis, while no longer formally associated with this contract. The delay in publication of this issue was occasioned by the need to change computer systems in midstream; we regret this delay, which should not reoccur. An index covering Issues 10 - 14 of the Digest should reach readers very soon. Particular attention is called to the special feature at the end of this issue, which provides information about Soviet drugs referred to in past issues of the Digest. Finally, readers are invited to let us know which of the abstracts contained in the book "Space Biology and Medicine" (pages 81-99) they would like to have translated in full in subsequent Digest issues; approximately 35 of the most relevant of these abstracts have already been translated for Digest Issue 15.

Please address correspondence to:

Dr. Lydia Razran Hooke  
Lockheed Engineering  
and Management Services Company  
600 Maryland Ave. SW  
Suite 600, East Wing  
Washington, DC 20024

## ADAPTATION

(See also: Immunology: P602; P620; Metabolism P613; Perception: P609;  
Space Biology: P592; M116; M117; CR7)

### PAPERS:

P617(14/87) Ushkalova VN, Kadochnikova GD.

#### **Use of lipid peroxidation parameters to study human adaptation to new climatic and geographic conditions.**

Byulleten' Eksperimental'noy Biologii i Meditsiny.

1987(5): 571 - 574.

[10 references; none in English]

Authors' affiliation: Department of Organic Chemistry, Tyumen' Medical  
Institute

Metabolism, Lipid Peroxidation; Hematology, Erythrocytes

Humans, Age Differences

Adaptation, North; Biorhythms, Seasons

**Abstract:** This paper describes the results of a study of concentrations of lipid peroxidation products in erythrocytes of workers from the southern regions of the USSR during adaptation to conditions in western Siberia. Subjects were 250 healthy individuals aged (20 to 50) monitored during weeks 1 to 40-50 of adaptation. Fifty local inhabitants matched for age served as controls. Concentrations of lipids with optical densities of 232 nm and 268 nm, providing estimates of presence of conjugated dienes and trienes, respectively, were measured in an erythrocyte suspension. Concentrations were obtained for 1 ml erythrocyte suspension and this figure was used to calculate level for 1 mg total lipids in 1 ml of erythrocyte suspension.

During the adaptation period, concentrations of lipid peroxidation products were elevated. Estimated concentration of conjugated dienes was 5 times as high in adapting subjects as in permanent residents, while that of conjugated trienes was twice as high. During the first 5-8 days of adaptation, diene level increased to 5 times baseline; over the next 20 days it dropped below baseline and then gradually increased over the next 20 weeks with local maxima at 15 or 25 weeks, depending on season of the year. Some fluctuation was noted during the next 2 years, but level was always below baseline. Concentration of trienes decreased during the initial adaptation period, reaching a minimum at day 20 and then increasing. [Note graph, table, and text do not appear to agree]. Changes in conjugated dienes during the acute and chronic phases of adaptation appeared to depend on season of the year. During the spring, increases were extreme during initial (acute) adaptation, followed by a sharp drop and little change (chronic adaptation). In the autumn, changes during the acute period were much less pronounced. However, during chronic adaptation the parameter increased by a factor of 3 over the next 15 weeks, dropping to baseline during the subsequent 10 weeks. Changes in lipid peroxidation products were highest for subjects between 31-35, and lowest for those between 20-30; levels for workers 36-40 were intermediate. The authors conclude that lipid peroxidation parameters are highly sensitive to the progress of adaptation.

P617

Table: Changes in blood parameters of lipid peroxidation as a function of age over a 1-year adaptation period

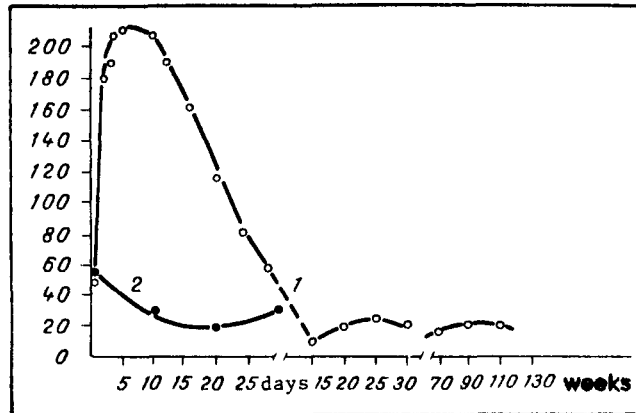

Figure 1: Change in optical density of lipid extracts as a function of adaptation duration  
 1 - OD<sub>232</sub>; 2 - OD<sub>268</sub>. Here and in Figures 2 and 3 optical density is computed for 1 ml erythrocyte suspension

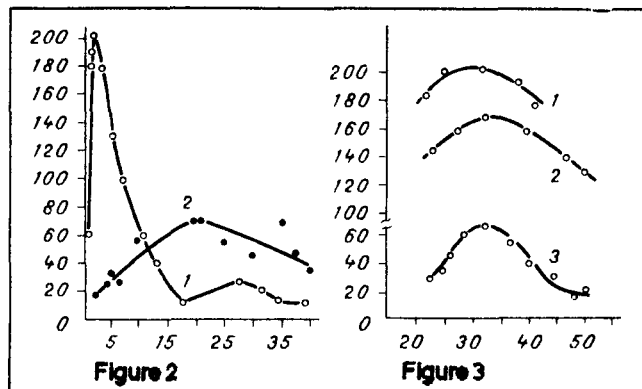

Figure 2: Concentration of diene conjugates in erythrocytes as a function of duration of adaptation in different seasons of the year  
 1 - spring; 2 - autumn

Figure 3: Concentration of diene conjugates in erythrocytes as a function of age for various durations of adaptation  
 1 - 9-11 days; 2 - 1 year; 3 - control

## ADAPTATION

P619(14/87) Lebedev MD, Bobrov NI, Keerig YuYa.

**Some parameters of human adaptation to extreme conditions in the Arctic.**

Gigiyena i Sanitariya.

1987(2): 18-21.

[10 references; none in English]

Authors' Affiliation: Rostov Medical Institute

Body Fluids, Renal Function

Humans, Males

Adaptation, Arctic, Long-term; Biological Rhythms, Diurnal Differences, Seasons

**Abstract:** Subjects in this study were 9 healthy men, aged 19-20, coming from temperate regions of the USSR to work in the Arctic (72°-73° north latitude). Subjects were observed for 2 years. Parameters selected for study as indicative of adaptation reflected the excretory function of the kidneys. Daily urine was collected three times at intervals of 10 days upon subjects' arrival in the Arctic and every 6 months subsequently during the day (7:00 to 19:00) and night (19:00-- 7:00). For each period, 27 urine samples were collected, each consisting of day and night portions. A total of 135 urine samples were analyzed. In each sample, parameters measured included volume, concentration of 17-oxycorticosteroid (17-OCS), total nitrogen, nitrogen ammonia, creatinine, and ions of sodium, potassium, calcium, and phosphorous. Ratio of metabolic products excreted during the day and night was computed. Deviations from normal diurnal fluctuation patterns were considered to indicate adaptive stress.

Results showed that during the first 15 days in the Arctic (in the summer), diurnal diuresis and renal excretion of the substances studied were normal, with rate of excretion higher during the day than during the night. Day:night ratio corresponded to the physiological norm for a moderate climate. During the polar winter, 6 months after subjects arrived, day:night ratio decreased for quantity of urine and 17-oxycorticosteroid; more nitrogen and nitrogen ammonia were excreted during the night (the reverse of the normal situation) and amounts of creatinine excreted were equal for day and night. Total daily renal excretion of urine, nitrogen compounds, 17-oxycorticosteroids, and creatinine increased during this period. One year after subjects arrived in the Arctic, the diurnal patterns of renal excretion tended to be closer to the norm than after 6 months. However, total excretion of 17-OCS was still significantly higher than the norm. After a year and a half in the Arctic, in the winter, amount of urine excreted during night and day were equal, as was the case with nitrogen ammonia and creatinine. Day/night differences in 17-OCS were attenuated compared to the norm and reversed in the case of total nitrogen. Total amount of 17-OCS in daily urine continued to be elevated. After 2 years in the Arctic, in the summer, parameters had returned to normal levels.

On subjects' arrival in the Arctic (summer), daily excretion of sodium, potassium, calcium, and phosphorous were within norms; day excretion of sodium and potassium were significantly higher than night excretion. Night excretion of calcium and phosphorous were greater than day values. After 6 months (winter), there was a significant increase in daily excretion of sodium and potassium and a tendency for excretion of the other two electrolytes to increase. For all electrolytes, night excretion increased over baseline, but this difference was not significant for potassium.



P619

After 1 year (summer), no significant differences from baseline values were found, although diurnal rhythms tended to be less pronounced. After a year and a half (winter), daily excretion of sodium was elevated significantly and that of the other electrolytes showed a tendency toward elevation. There was also a tendency for diurnal rhythms to be reestablished. After 2 years, excretion patterns did not differ substantially from the norm. The authors relate these results to development of "polar stress syndrome," the main characteristic of which is activation of the adaptive systems (pituitary, adrenal cortex, nitrogen-based and mineral metabolism in cells and tissues, etc.). Results show this syndrome to be most pronounced after 6 months, stabilizing after 2 years.

Table 1: Renal excretion of 17-OCS and nitrogenous substances as a function of length of service in the Arctic, season of the year and time of day

Table 2: Renal excretion of electrolytes as a function of length of service in the Arctic, season of the year, and time of day

**BIOLOGICAL RHYTHMS:** See Adaptation: P617, P619

### **BODY FLUIDS**

(See also Adaptation: P619; Space Biology: P592, CR7, M117)

#### **PAPER:**

P624(14/87) Grigoryev AI, Ushakov AS, Popova IA, Dorokhova BR, Ivanovna SM, Davydova NA, Afonin BV.

**Fluid-electrolyte metabolism and renal function [in Salyut-6 prime crews].**

In: Gurovskiy NN, editor.

Rezultaty meditsinskikh issledovaniy vypolnennykh na orbital'nom nauchno-issledovatel'skom komplekse "Salyut-6"- "Soyuz" [Results of medical research performed on board the "Salyut-6"- "Soyuz" orbital scientific research complex].

[See Digest issue 13: Space Medicine: M112].

Moscow: Nauka; 1986; pages 145-149. Note: the portion of this chapter dealing with other metabolic factors will be abstracted in a subsequent Digest issue.

[79 references; 27 in English]

Body Fluids, Fluid-electrolyte Metabolism, Renal Function  
Humans, Cosmonauts  
Space Flight, Long-term, "Salyut-6"

**Abstract:** Fluid-electrolyte metabolism and renal function were studied in prime crewmembers preflight and for a long period postflight. Studies corrected for intake of food and fluid. Provocative tests were used in the study of renal function. To examine regulation of fluid-electrolyte metabolism, radioimmune methods were used to determine hormonal activity of renin, aldosterone, parathyroid hormone, and calcitonin in blood. In addition, concentration of sodium, potassium, calcium, magnesium, chlorine, and osmotically active substances were measured in urine and blood serum or plasma.

It has been hypothesized that as space flights increase in duration initial changes in volume of extracellular fluid and blood plasma gradually level off. It was indeed found that on the first day after long-term flights positive fluid balance was less pronounced than after short-term flights. Diuresis decreased by only 0.12 ml/min, while fluid intake increased by 0.4 ml/min. Retention of sodium was more pronounced after long-term flights. Postflight osmotic concentration of urine was below baseline levels. A provocative test with fluid loading performed on cosmonauts completing one 96-day flight appeared to indicate that renal capacity to osmotically dilute urine decreased less than after a 30-day flight. After fluid loading, excretion of calcium and magnesium increased by a factor of 2.7-5.9 compared to preflight levels. Rate of glomerular filtration did not change. Changes in other parameters were attributable to decreased reabsorption of calcium and magnesium in the urinary tract. After 30- and 63-day flights excretion of calcium increased by a factor of 1.8-2.2 and after a 96-day flight it increased by a factor of 5, while sodium excretion remained the same.

P624

Increased calcium excretion after long-term flight was noted in the absence of fluid loading. Except for the first 2 days postflight, calcium excretion exceeded control level. Analysis of urine samples obtained during the flights indicated that calcium excretion peaked toward the end of month 1 and did not increase further. Study of concentration of parathyroid hormone and calcitonin in blood on day 1 postflight revealed no regular pattern of changes. Response to a calcium loading test was greater postflight than preflight. Past and present data suggest that changes in calcium metabolism are correlated with flight duration. Individual differences are great in this indicator. Excretion of potassium and aldosterone in response to potassium loading was higher postflight.

The authors conclude on the basis of their results and other data that shifts in ion metabolism during and after space flight, as well as after long-term hypokinesia, are caused primarily by metabolic factors and associated changes in the endocrine system. The most probable cause of loss of potassium and calcium during and after space flight is likewise decreased capacity of tissue (especially muscle and bone) to retain electrolytes. Increased renal excretion of electrolytes as a consequence of altered activity of hormonal systems is a secondary process serving to maintain a constant concentration of ions in the blood.

## BOTANY

(See also: Space Biology: CR7; M116; M117)

### PAPER:

P607(14/87)\* Kovalev YeYe, Brill' OD, Nevsgodina LV, Ivanov LI, Yanushkevich VA.

**Simulation of the effects of an impact wave from heavy charged particles on biological subjects.**

Kosmicheskaya Biologiya i Aviakosmicheskaya Meditsina.

21(4): 73-76; 1987.

[7 references; 2 in English]

Botany, Bioeffects, Simulation, Viability, Mitosis, Aberration

Lettuce, Seeds

Radiobiology, HZE, Impact Wave

**Abstract:** The goal of this experiment was to study the effects of impact waves simulating those on the track of heavy charged particles. Biological subjects were lettuce seeds. The waves used were flat impact waves generated during absorption of a laser impulse with wavelength of 50 nsec and energy of 10-15 J by a thin, opaque layer of black enamel approximately 1 cm<sup>2</sup> in area. Figure 1 diagrams the apparatus used. The amplitude of pressure for the impact wave on exiting the absorbent layer was about 10,000 atm. Subjects were air-dried lettuce seeds and moistened seeds (sprouts), 3-4 mm in length and 0.5-1 mm in diameter. Before irradiation 10 seeds or sprouts were attached along the radii of the lower disk so that their ends touched in the disk's center. This allowed the central portion of the wave to strike the most sensitive area, the apical root meristem. Immediately after irradiation the seeds were soaked in distilled water to remove the fixative and placed on moistened filter paper in a Petri dish for sprouting. Some of the sprouting seeds were fixed and subjected to cytogenetic analysis. Effects of irradiation were assessed on the basis of number of sprouts surviving until day 10 after irradiation, and also the number of aberrant and dividing cells in the sprouts. Parameters were compared to those of a nonirradiated control group. Three experiments were performed over a period of 4 months. In each, the seeds were irradiated at several pressure amplitudes within a range of from several hundred to 13,000 atm.

Impulse waves significantly affected viability and sprouting time. These effects occurred at 1000-2000 atm for dry seeds and 200-300 atm for moistened seeds. The impact wave also decreased cell division (by a factor of 2 at 800 atm) compared to control. However, there was no increase in chromosomal aberrations. For comparative purposes, air-dried lettuce seeds were irradiated with beta rays from Sr<sup>90</sup> and Y<sup>90</sup> at doses of 3.3-220 Gy. Although seed viability did not decrease even at maximum dose, cell division was inhibited, e.g., by a factor of 2 at 120 Gy. Increased radiation dose led to increased multiple aberrations. The authors conclude that the primary effects of impact waves are mechanical damage at the microscopic and submicroscopic levels with less damage at the molecular level. This study demonstrates that certain very sensitive biological subjects may be damaged by impact waves with pressure of several tens of atmospheres, such as occur in the vicinity of the track of heavy charged particles.

P607

Table 1: Percent of cells with chromosome aberration in lettuce seeds irradiated with impact waves varying in amplitude

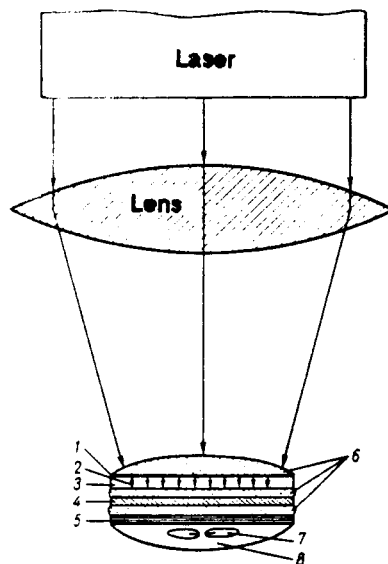

Figure 1: Diagram of experimental apparatus

1- enamel; 2 - flat impact wave; 3 - acrylic plastic; 4 - copper; 5 - aluminum; 6 - polyvinyl alcohol; 7- seeds; 8 - epoxy resin

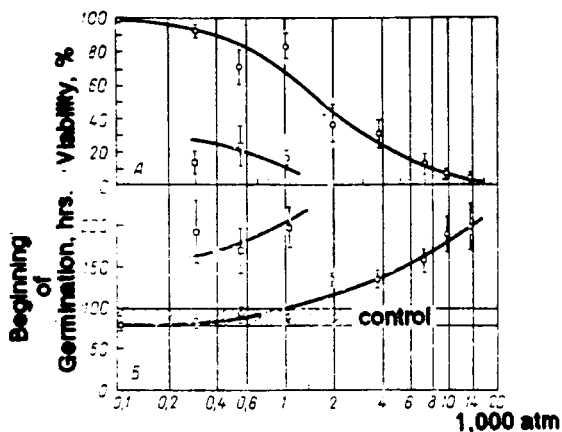

Figure 2: Viability on day 10 (A) and retardation of sprouting (B) of dry (circles) and moistened (squares) lettuce seeds exposed to impact waves as a function of pressure in the front of the impact wave

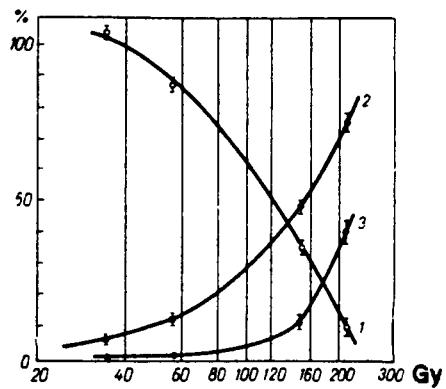
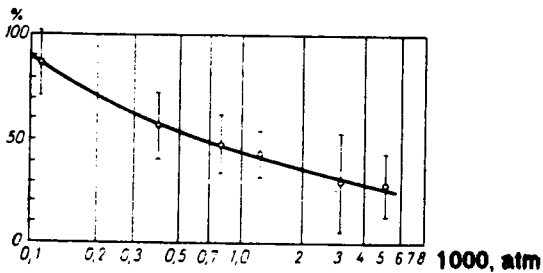

Figure 3: Relative rate of cell division in lettuce seeds as a function of impact wave amplitude

Figure 4: Relative rate of cell division, percent of aberrant cells and number of multiply aberrant cells in lettuce seeds as a function of dose of beta irradiation.

## CARDIOVASCULAR AND RESPIRATORY SYSTEMS

(See also: Endocrinology: P608; Mathematical Modeling: P614; Space Biology: M116, M117)

### PAPERS:

P594(14/87)\* Sokolov VI, Yarullin KhKh, Vikharev ND, Sazonova MV, Degterenkova NV.

**Circulatory response to hypokinesia with head-down tilt in males aged 45-52.**

Kosmicheskaya Biologiya i Aviakosmicheskaya Meditsina.

21(4): 22-26; 1987.

[23 references; 8 in English]

Cardiovascular and Respiratory Systems, Circulation, Central and Regional, Brain

Humans, Males, Older, Arteriosclerosis, Neurocirculatory Distonia Hypokinesia, Head-down Tilt

Abstract: The effects of 30 days of hypokinesia with head-down tilt of  $-8^{\circ}$  on central and regional hemodynamics was studied in 15 males aged 45 to 52. Of these 10, (group 1) suffered from the initial symptoms of arteriosclerosis of the brain and aorta and 5 (group 2) from hypertensive neurocirculatory distonia and stage I hypertension. Cerebral hemodynamics were studied in the basin of the internal carotid arteries and in the vertebrobasilar system using bipolar impedance plethysmography recording on an 8-channel electroencephalograph. The following parameters were computed: A (in ohms) the maximal amplitude of the plethysmogram, reflecting pulsed blood perfusion of the vessels;  $\alpha/T$  (in percent) relative duration of the anacrotic phase on the plethysmogram, reflecting the elasticity and tonus of large and medium caliber vessels; dicrotic (DCI) and diastolic indices (DSI), reflecting changes in tonus of small arteries and veins, and precapillaries and veins and venules, respectively; and amplitude of venous waves on the plethysmogram, reflecting vascular tonus and outflow. A study of cerebral circulation was conducted in conjunction with an encephalographic study of reactions of the ventricular system of the brain. An index was computed for the III ventricle (Dvi) and the medial wall of the lateral ventricle (Pmj). Changes in the ratio of ventricle to brain tissue reflect changes in intracranial liquor pressure. Tetrapolar impedance plethysmography was used to study cardiac stroke volume and circulatory minute volume. Blood pressure parameters (diastolic, mean, true systolic, systolic and pulse) were also measured. Hemodynamics were additionally studied in the lung, kidney, and calf. Measurements were made before hypokinesia, on days 2, 6, 17, and 27 of the treatment and on days 5 and 9 of readaptation.

Before hypokinesia, group 1 showed localized and group 2 general increase in the tonus of large and small resistant vessels in the brain. The high tonus of intracranial veins in group 2 subjects was accompanied by impeded venous outflow from the head and distension of the lateral ventricles of the brain, suggesting compensatory hydrocephalus. Group 1 individuals displayed elevated stroke volume, which served to maintain an adequate cardiac ejection fraction. On day 2 of hypokinesia, individuals in group 1 displayed elevated pulsed blood perfusion in brain vessels (especially on the left side) with enhanced interhemispheric asymmetry, accompanied by constriction of large and medium vessels of the brain.

P594

Maximum value of  $\alpha/T$  occurred during days 6-17 and cerebral circulation normalized on day 17. Group 1 subjects typically showed substantial changes in hemodynamics of the vertebrobasilar system, manifested in decreased pulsed blood perfusion and increased resistance of cerebral vessels, evidently as a result of active vasoconstriction and decreased vasoconstrictive capacity. Analogous phenomena were noted in group 2. On day 2, tonus of arterioles and veins was elevated and venous outflow impeded in the vertebrobasilar system. This continued until day 17. On day 6 indicators of increased spinal fluid pressure in the skull were observed. Increased pulsed blood perfusion in the carotid basin made it possible to compensate for hemodynamic shifts in the vertebrobasilar system. These phenomena were accompanied by hypervolemia in the upper portion of the right lung and hypovolemia of the liver. Heart rate of group 1 subjects was depressed by 14.9% on day 6 and elevated by a similar percent on day 27. On day 17 minute volume and stroke volume were depressed in this group.

In group 2 subjects, changes in cerebral hemodynamics were insignificant during hypokinesia. However, pulsed and venous blood perfusion were elevated in the upper portions of the lung and liver. These subjects did show significant decreases in systolic and true systolic blood pressure, leading to decreased pulse pressure. Heart rate tended to decrease and stroke volume was unchanged. On day 27 of hypokinesia, subjects in both groups displayed increases in blood pressure, vascular tonus, and heart rate. However, these may be attributed to psychological reaction to impending termination of the treatment. During the readaptation period, hemodynamic parameters normalized in both groups. The recovery process was slower in group 2 subjects. The authors conclude that when considering the potential effects of weightlessness on individuals of this age, it is important to consider the possible presence of cardiovascular disease.

Figure 1: Changes over time in plethysmographic parameters of the brain in subjects of groups 1 and 2 during hypokinesia with head-down tilt

Figure 2: Changes over time in parameters of central hemodynamics during hypokinesia with head-down tilt



P595(14/87)\* Gansburgskiy AN.

**Morphometric analysis of aortic endothelia of rats exposed to long-term hypokinesia.**

Kosmicheskaya Biologiya i Aviakosmicheskaya Meditsina.

21(4): 26-28; 1987.

[9 references; 2 in English]

Cardiovascular and Respiratory Systems, Aortic Endothelium, Morphometry  
Rats, Male  
Immobilization, Psychology, Stress

**Abstract:** Morphometric analysis was performed on thin sections of the aortic endothelia of 48 male white rats. Experimental (N=24) rats were sacrificed after spending 30, 60, or 100 days in immobilization cages. Control rats (N=24) were maintained in ordinary laboratory conditions. The aorta was removed and sections prepared and stained. A stereological optical grid with 27 equidistant points was used to calculate the mean area of endotheliocytes, as well as their nuclei and cytoplasm, and the ratio between them. In addition, karyopyknotic, karyolytic, and binucleate endothelial cells were counted.

In comparison to control animals, experimental rats displayed increased numbers of karyopyknotic, karyolytic, and binucleate cells at all intervals measured. After 30 days of hypokinesia, the area of endotheliocytes, as well as of their nuclei and cytoplasm was significantly greater than control, while nucleus/cytoplasm ratios were equivalent. On days 60 and 100, cell and cytoplasm areas were at control level, while nucleus area and nucleus/cytoplasm ratio were significantly depressed. The authors argue that the changes observed at all intervals can significantly depress the regenerative capacity of endotheliocytes. These changes would be particularly dangerous if combined with factors causing hypercholesterolemia, since an elevated level of cholesterol and atherogenic fractions of lipoproteins in plasma can lead to destruction of the endothelium.

**Table:** Value of certain morphological parameters of the aortic endothelium of rats exposed to long-term hypokinesia

## CARDIOVASCULAR AND RESPIRATORY SYSTEMS

P599(14/87)\* Yarullin KhKh, Simonov LG, Vtoryy SA.

Changes in regional and central hemodynamics induced by a 7-day period of immersion in water.

Kosmicheskaya Biologiya i Aviakosmicheskaya Meditsina.

21(4): 45-50; 1987.

[19 references; 7 in English]

Cardiovascular and Respiratory Systems, Hemodynamics, Central, Regional,  
Brain, Liver, Lungs  
Humans, Males  
Immersion

Abstract: Six healthy men (aged 41-49) were subjected to 7 days of dry immersion. Before, during (days 1, 3, 5, and 7), and on the fifth day after this treatment, impedance plethysmography was performed on the brain using fronto-mastoids and bimastoid leads in order to gain information about hemodynamics in the basin of the internal carotid artery and vertebrobasilar system); in addition, plethysmograms were obtained of the right lung, liver, calves and fingers. Magnitude of pulsed blood perfusion was estimated from the maximal amplitude of the plethysmogram. In addition, experimenters calculated the relative duration of the anacrotic phase of the plethysmogram ( $\alpha/T\%$ ) as an indicator of the tonus and elasticity of large and medium vessels; diastolic and dicrotic indices as indicators of the tonus of arterioles, small arteries, venules and small veins, respectively. The diastolic index thus reflects venous outflow. In addition, blood pressure, cardiac stroke volume, and circulatory minute volumes were measured. It should be noted that all six subjects also participated in a study involving 8 days of hypokinesia with head-down ( $-8^\circ$ ) tilt and its effects on the same parameters of regional and central hemodynamics. [See Abstract P594 this issue.] Thus, these two weightlessness models can be compared on the same subjects.

The major results of these treatments are shown in Figures 1-4. Increased blood perfusion in the brain, lungs, and arms was greatest on days 3-5 of immersion. Outflow to the liver began on day 5 as the result of a compensatory reaction. Hypokinesia with head-down tilt had similar, but less pronounced, effects on regional and central hemodynamics than did immersion. However, orthostatic and LBNP tests performed after the treatments revealed that functional deconditioning was similar after both treatments. The authors explain this by postulating greater activation of compensatory and adaptive mechanism in immersion.

P597

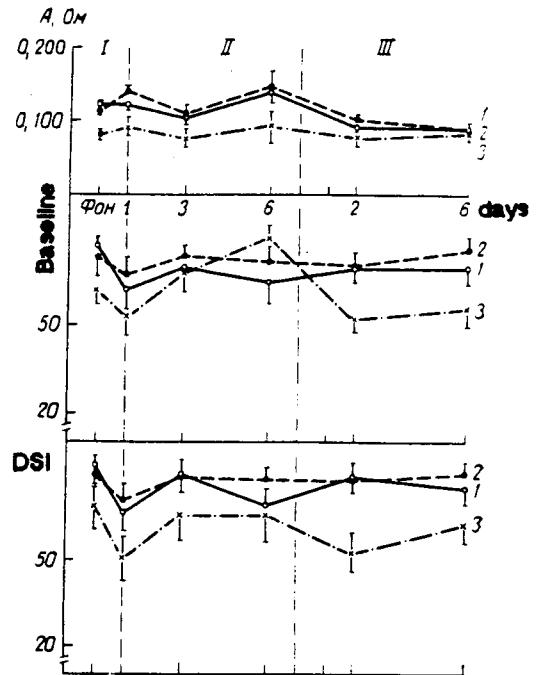
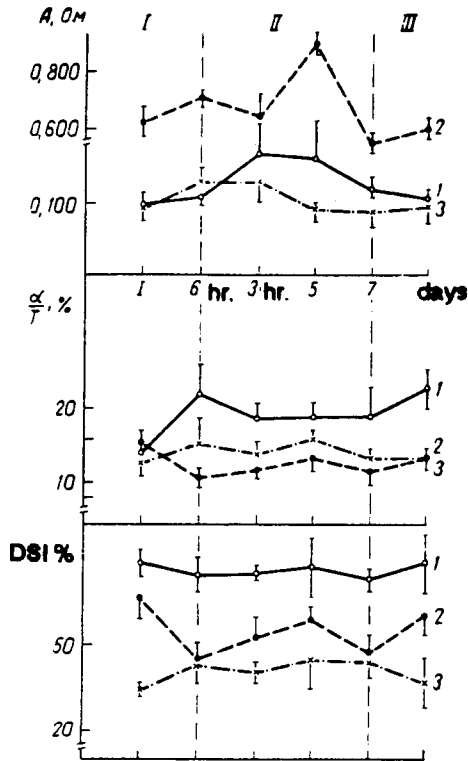

Figure 1: Changes over time in the mean value of impedance plethysmographic parameters of the right hemisphere (1), middle finger of the right hand (2), and right calf before (I), during (II), and after (III) a 7-day period of water immersion in six healthy men

Figure 2. Changes over time in the mean value of impedance plethysmographic parameters before (I), during (II) and after (III) an 8-day period of hypokinesia with head down tilt ( $-8^{\circ}$ ) in six healthy men.

1 and 2 - right and left front-mastoid leads, respectively; 3 - bimaastoid lead

CARDIOVASCULAR AND RESPIRATORY SYSTEMS

P597

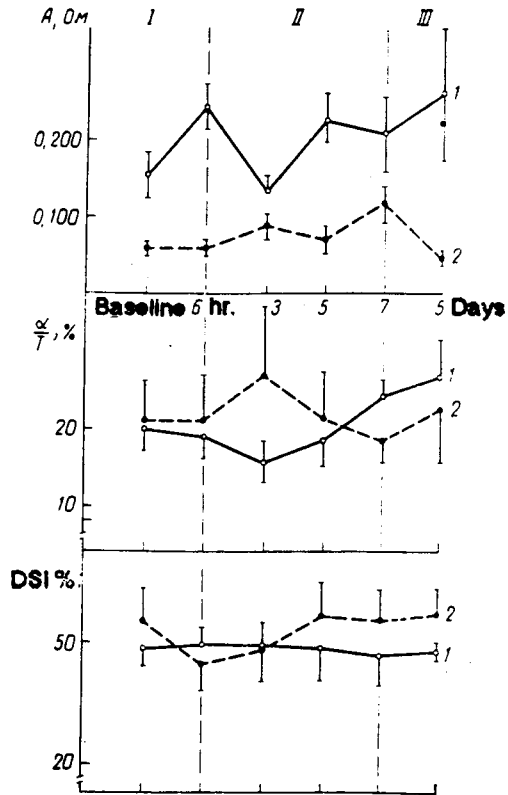
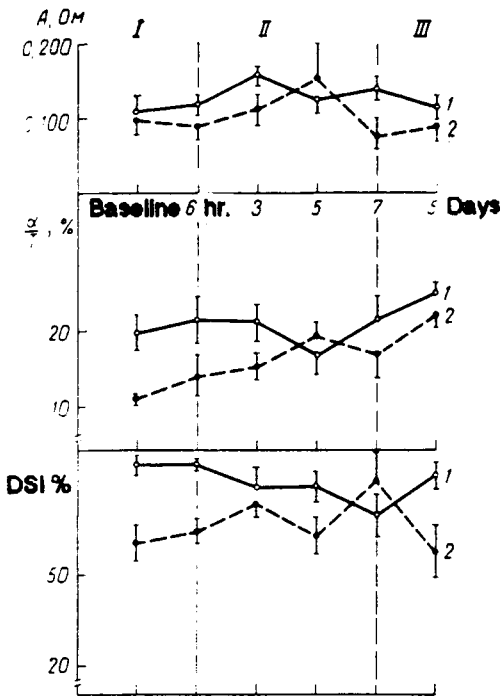

Figure 3: Changes over time in the mean value of impedance plethysmographic parameters of the left hemisphere (1) and bimastoid lead (2) in six subjects after (I), during (II) and after (III) 7 days of immersion

Figure 4: Changes over time in the mean values of impedance plethysmographic parameters of the right lung (1) and liver (2) in six subjects before (I), during (II) and after (III) 7 days of immersion

## CARDIOVASCULAR AND RESPIRATORY SYSTEMS

P604(14/87)\* Kondrakov VM, Koledenok VI, Suvorov PM, Arsen'yeva LI.  
**Diagnostic significance of provocative tests in evaluating nonspecific changes in electrocardiograms.**

Kosmicheskaya Biologiya i Aviakosmicheskaya Meditsina.

21(4): 67-69; 1987.

[14 references; none in English]

Cardiovascular and Respiratory Systems, Diagnosis, Myocardium  
Humans  
EKG Changes, Provocative Tests

**Abstract:** This paper describes a study of the diagnostic utility of provocative tests in differential diagnosis of cardiogenic and non-cardiogenic changes in the myocardium, relative to the goals of medical flight certification exams. Subjects were 353 individuals, aged 19-52 years, with EKGs showing changes in the shape and/or polarity of T-waves at rest. These subjects were divided into two groups on the basis of general clinical examinations. The first group included 189 individuals identified as suffering mainly from symptoms of autonomic-vascular dystonia: lack of emotional stability, blood pressure and pulse lability, persistent red dermatographism, hyperhydration, etc. The second group included 164 individuals who periodically became out of breath and experienced irregularities in heartbeat during physical exercise. The majority of these were characterized by two or three risk factors for ischemic heart disease. No subject had suffered from myocardial infarction or complained of chest pain, but all did show symptoms of coronary arteriosclerosis. Provocative tests administered included tests with potassium chloride and obzidan (propranolol hydrochloride). Some subjects also participated in an orthostatic test and a test involving intentional hyperventilation. Obzidan in a dose of 0.5 mg per 1 kg weight and potassium chloride in a dose of 1 g per 10 kg weight were administered on different days. EKG was recorded using the traditional 12 leads during a baseline period and 1 and 1.5 hours after ingesting the drug. The active orthostatic test lasted 30 minutes, during which the subjects stood still. EKG was recorded in a horizontal position and after shift to a vertical position, then after each 15 minutes in a standing position, immediately after the test terminated, and during the first 5 minutes of the recovery period (in a horizontal position). The intentional hyperventilation tests instructed subjects to breathe as deeply and rapidly as they could (30-50 breaths/minute) for 1 minute. EKG was recorded before the test, immediately after, and every 30 seconds during the first 3 minutes of rest.

When potassium chloride was administered, EKGs of 158 members of the first group normalized completely; in the remainder only an insignificant elevation in T wave voltage occurred. In 120 members of group 2, no changes occurred in EKG; in 28 there was a deepening of inverted T waves; and in 16 some improvement was seen in the terminal portion of the ventricular EKG complex. When obzidan was administered, repolarized disturbances of the myocardial completely disappeared in 149 out of 167 members of group 1 and in 19 subjects improved only slightly. In 41 of 68 group 2 members, obzidan led to enhanced repolarization, and in 30 slight increase of T voltage in 2 or 3 leads. Existing data in the literature indicate that when myocardial damage results from a functional disturbance (excessive sympathetic activity or decreased electrolyte membrane transport), the adrenal blockade associated with obzidan and the normalizing effects of potassium on the membrane

## CARDIOVASCULAR AND RESPIRATORY SYSTEMS

P607

lead to normalization. This explains the effects of these drugs on the majority of subjects in group 1. If myocardial disease is organic, these substances will not normalize cardiac function. Results indicate that most subjects in group 2 suffered from functional problems. Orthostatic tests indicated worsening of repolarization in the majority of subjects in group 1 and in a few group 2 subjects. The hyperventilation test led to EKG changes identical to those associated with the orthostatic probe in most subjects in group 1, while EKGs of all subjects in group 2 and the minority in group 1 remained unchanged. The authors recommend using these tests to identify the genesis (functional or organic) of changes in the ventricular portion of EKGs and confirm diagnoses.

## CARDIOVASCULAR AND RESPIRATORY SYSTEMS

P622(14/87) Yegorov AD, Itsekhovskiy OG, Alferova IV, Turchaninova VF, Polenova AP, Golubchikova ZA, Domracheva MV, Lyamin VR, Turbasov VD. [Study of the cardiovascular system (of Salyut-6 prime crews.)]

In: Gurovskiy NN, editor.

Rezultaty meditsinskikh issledovaniy vypolnennykh na orbital'nom nauchno-issledovatel'skom komplekse "Salyut-6"- "Soyuz" [Results of medical research performed on board the "Salyut-6"- "Soyuz" orbital scientific research complex].

See Digest issue 13: Space Medicine: M112.

Moscow: Nauka; 1986; pages 89-114.

[86 references; 33 in English]

Cardiovascular and Respiratory Systems, Cardiovascular Parameters  
Human, Cosmonauts  
Space Flight, Long-term, "Salyut-6"

**Abstract:** This paper describes results of studies of the cardiovascular systems of members of Salyut-6 prime crews. Results of impedance plethysmographic studies of the regional hemodynamics of these cosmonauts revealed redistribution of cardiac ejection, which in every case was manifested as decreased pulsed perfusion in the calves throughout the entire flight. Some cosmonauts also displayed increased pulsed perfusion in the head lasting for 3-4 months and longer.

In the majority of cosmonauts studied, heart rate showed a tendency to increase during month 2 of flight. Changes in the phase structure of the cardiac cycle were manifested in flight by statistically significant shortening of the isometric contraction and relaxation phases and, in most cosmonauts, by lengthening of the ejection period and the rapid filling phase. Marked decrease in the interphase coefficient and a tendency for the myocardial stress index to decrease were also observed. Rate of elevation of intraventricular pressure increased, while rate of blood ejection from the left ventricle decreased. During the first 7-10 days of flight, stroke blood volume increased somewhat and then decreased slightly. Minute volume showed virtually no changes throughout the flights. In the majority of cosmonauts, blood pressure parameters remained unchanged or decreased slightly. Specific peripheral resistance and its relationship to the required values decreased in all cosmonauts. Rate of propagation of a pulse wave in the aorta increased in flight but did not depend on flight duration. Regional dynamics were studied using impedance plethysmography. Parameters of pulsed and minute blood perfusion of brain vessels increased in 6 of 10 cosmonauts. Blood perfusion parameters exceeded preflight levels throughout the 96 day flight. During the 140-day flight and in one of the cosmonauts on the 175 day flight perfusion of cerebral vessels returned to baseline or decreased after 3-4 months. Maximum deviations from preflight were displayed by nearly all the cosmonauts during days 50-85.

Tonus of large and medium size arteries of the cerebral hemispheres changed in different directions during flight. Tonus of pre- and post-capillary vessels decreased. Some cosmonauts showed signs of venous congestion and marked dilation of small vessels. Decreased pulsed perfusion in the calves was noted in all cosmonauts throughout the flight; however, some showed a normalizing tendency in this parameter toward the end of the flight. Tonus of large and medium sized arteries of the calves decreased while irregular changes were observed in small vessels. Pulsed perfusion of the

P622

forearm remained the same or increased. Venous pressure in the jugular vein exceeded preflight level by a factor of 2-4. Blood perfusion of the jugular veins also increased in flight, as indicated by an increase in presystolic and diastolic waves on pulsograms. Venous pressure in the calf decreased during flight, approaching the level in the forearm. Thus the pressure gradient was attenuated or absent. Distensibility of the venous reservoir of the calves increased greatly, while in the forearm it remained the same. Contractility of veins in the calves decreased, but tended to normalize toward the end of the flight in some cases. Contractility in the forearms increased, testifying to relatively high vascular tonus.

Postflight echocardiographic examination revealed decreases in the volume of the left ventricle and stroke ejection. At the same time, myocardial contractility parameters were virtually unchanged. Hemodynamic changes were transitory; recovery time appeared to depend on level of physical conditioning.

The authors offer the conceptual model on the next page to represent the mechanisms leading to the observed cardiovascular effects of weightlessness.



P622

Possible mechanisms underlying cardiovascular changes in weightlessness

Weightlessness

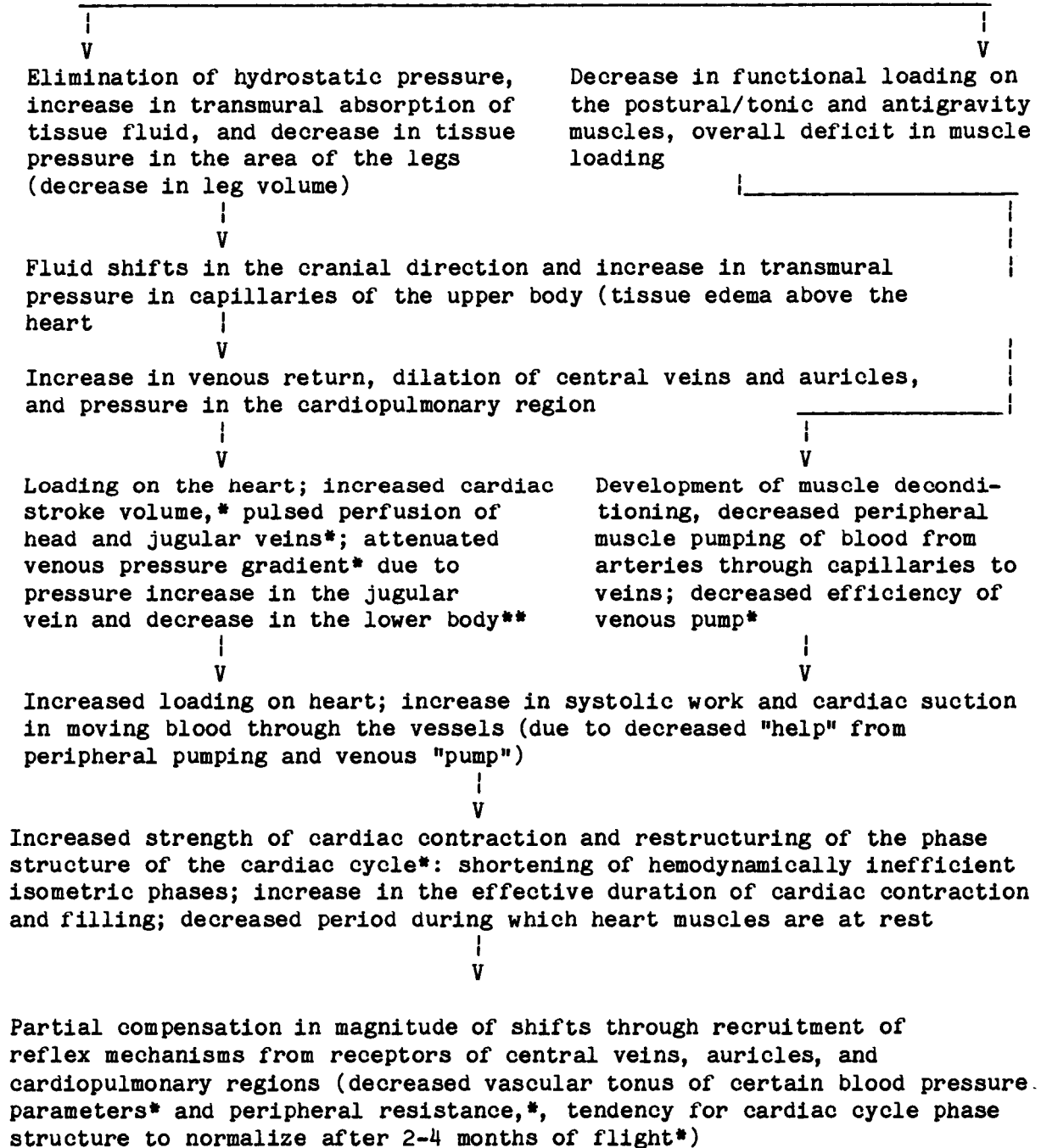

\* Data obtained from space flights

\*\* Tendency for pressure in veins of various regions to stay at the level of central venous pressure or right arterial pressure

P622

**Development of compensatory reactions of the cardiovascular system in weightlessness**

Development of reflex reactions from the receptors of the central veins, auricles, and cardiopulmonary area resulting from their dilation by increased blood volume

↓  
V

Inhibition of the vasomotor center, increase in tonus of the vagus, and activation of unloading reflexes from the receptors of the pulmonary vessels limiting blood flow to the heart and decreasing tonus of the vessels in systemic circulation (inflight there is a tendency toward decreased arterial pressure and peripheral resistance)

↓  
V

Elimination of a portion of the liquid through the Henry-Gauer mechanism and decrease in central blood volume as a result of increased blood pooling when the receptors of the auricles and pulmonary vessels are stimulated

↓  
V

Partial compensation for the magnitude of the shifts: normalization of stroke volume; normalization of the duration of the ejection period and tendency of other cardiac cycle parameters to normalize beginning on month 2-3 of flight; stabilization of new functional level of circulation due to activation of mechanisms from the carotid sinus.

The most general conclusions about change in the bioelectrical activity of the myocardium (EKG with 12 standard leads) in- and postflight involve a transitory disruption of the end portion of the ventricular complex. This was manifested by an increase in the ratio of the middle depolarization to repolarization vector during and after the flight and in a postflight decrease in the vector of middle polarization and  $T_{V1-6}$ . Overall EKG changes were not clinically significant, did not affect hemodynamics or cosmonaut health, and typically had normalized by day 30 postflight.

Provocative tests with lower body negative pressure were used to study orthostatic tolerance during space flight and predict postflight deconditioning. A two stage LBNP schedule of -25 mm Hg, 2 minutes; -35 mm Hg, 3 minutes was used. Responses to the test pre- and inflight include: lack of unpleasant sensations; increased heart rate; decreased cardiac stroke volume; increased peripheral resistance and rate of propagation of pulse waves through the aorta; decreased pulsed perfusion in the vessels of the head; increased hemodynamically inefficient isometric phases of ventricular contraction and relaxation; lengthened tension and relaxation of the contractile components of the myocardia in preparation for ejecting blood from the heart or for filling it with blood; shortening of the effective duration of a cardiac contraction (decreased ejection period and intrasystolic parameter); decreased productive filling function due to shortened rapid filling phase. Shifts in parameters of systolic phase structure corresponded to the phase syndrome of myocardial hypodynamia. In virtually all the long-term (1 month or more) flights, responses to provocative LBNP tests were more pronounced than on Earth.

P622

The characteristics of LBNP response in space include: initial relative dehydration, decrease in volume of circulating blood and interstitial fluid; decreased vascular tonus and deconditioning of the mechanisms of venous return; increased distensibility of the veins of the calf as a result of decreased muscle tonus and tissue pressure; greater shifts of blood from the chest cavity to the vessels in the decompression zone; greater increase in the volumes of the legs as a result of increased capacity of veins; decrease in tonus of muscle surrounding the veins and decreased tissue pressure; more pronounced decrease in venous return, cardiac stroke volume; decreased activity of receptors in the cardiopulmonary region and increased activity of the vasomotor center with intensified adrenergic effects; enhanced compensatory reactions in the form of more pronounced increase in heart rate and peripheral resistance. The authors argue that these results are linked with relative hypervolemia of the upper body, with increased blood pooling in the cardiopulmonary area accompanying hypovolemia in the lower body with decreased tissue and venous pressure, and decreased vascular tonus.

Provocative tests with graded physical activity were performed inflight to evaluate cardiovascular status and physical work capacity. These tests used a bicycle ergometer with loading of 750 kgm/min for 5 minutes. Results of these tests can be summarized as follows.

Initial state before the test:

- \* decreased total blood volume and interstitial fluid;
- \* increased blood volume in the cardiopulmonary region;
- \* elevated distensibility of veins in the calf resulting from decreased muscle tonus and tissue pressure;
- \* formation of areas of free venous distensibility in the calf, not including tension of muscle of the venous walls due to sharp decrease in transmural pressure.

Changes during the test:

- \* diminished or absent increases in venous return and cardiac stroke volume due to initial decrease in the volume of circulating blood and increase in blood filling the venous reservoir of the lower limbs (at the stage of early restitution, the tension of the walls of veins in the working and nonworking limbs decreased);
- \* greater redistribution of a portion of the blood from the pulmonary area into the veins of the legs as a consequence of the free distensibility zones in the legs;
- \* more pronounced decrease in blood volume and pressure in the cardiopulmonary area and reflex enhancement of adrenergic effects.

Overall, changes in the circulatory system in response to provocative tests administered on long-term space flights suggest the absence of any clear signs of physical deconditioning in the majority of cosmonauts, evidently as a result of exercise performed in flight.

The authors argue that cardiovascular changes in response to provocative tests in flight are caused by changes in the initial state of hemodynamics in weightlessness before the test (i.e., decreased volume of circulating blood, increased distensibility of veins in the calves, and possible

CARDIOVASCULAR AND RESPIRATORY SYSTEMS

P622

formation of zones of free distensibility in this area), and the development during LBNP and in the period of early recovery after exercise of decreased central blood volume with reflex enhancement of adrenergic effects.

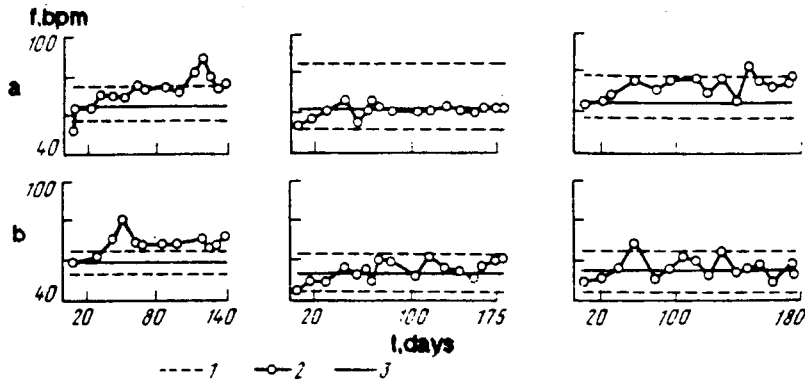

Figure 8: Changes over time in heart rate (f) at rest in captains (a) and flight engineers (b) on 140-, 175-, and 185-day flights  
 1 - limits of preflight fluctuations, 2 - mean for flight, 3 - mean preflight level

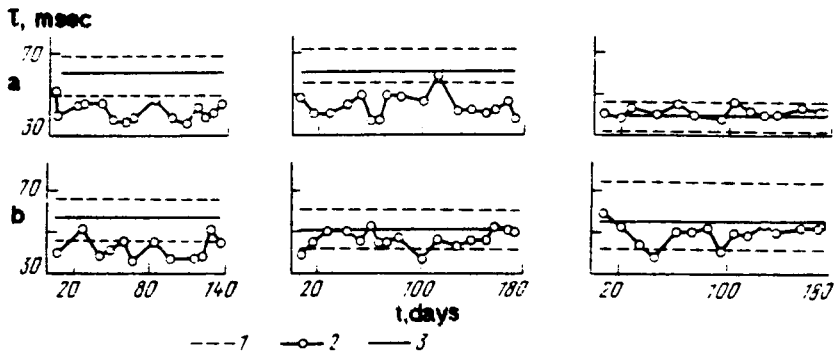

Figure 9: Changes over time in duration of the isometric contraction phase ( ) of the left cardiac ventricle at rest in captains (a) and flight engineers (b) on 140-, 175-, and 185-day space flights. Key: as in Figure 8.

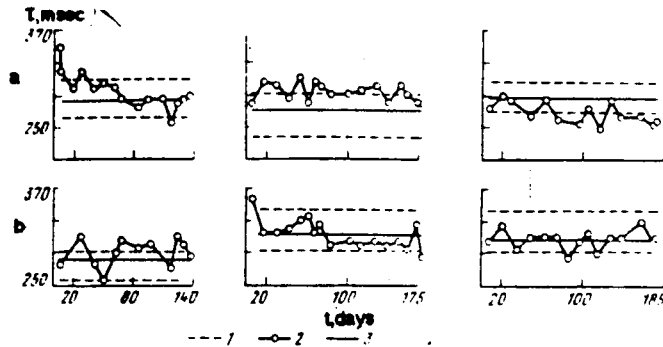

Figure 10: Changes over time in the ejection period ( ) of the left cardiac ventricle in captains (a) and flight engineers (b) on 140-, 175-, and 185-day flights. Key: as in Figure 8

P622

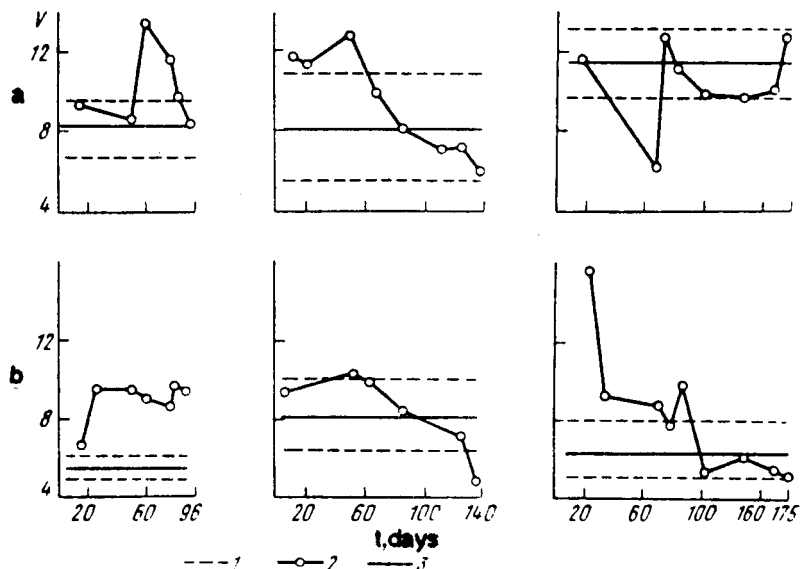

Figure 11: Changes over time in pulsed blood perfusion of vessels (V) of the head in captains (a) and flight engineers (b) on 96-, 140-, and 175-day flights. Key: as in Figure 8

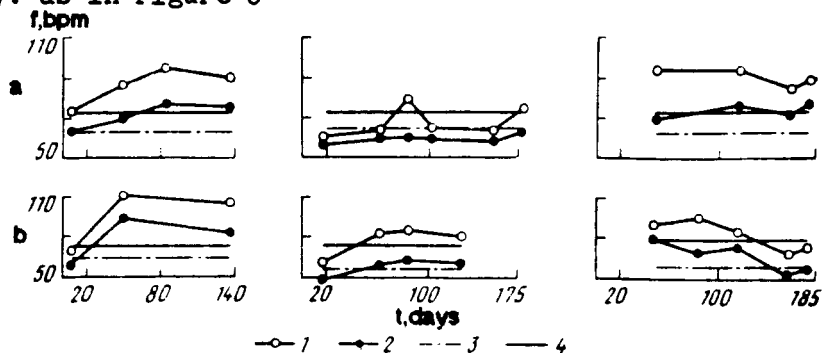

Figure 12: Changes over time in heart rate (f) in captains (a) and flight engineers (b) in response to LBNP on 140-, 175-, and 185-day flights  
 2 - in flight before the test; 1 - at -35 m Hg preflight; 3 - before the test; 4- at -35 mm Hg LBNP [sic: Key in original appears to be out of order.]

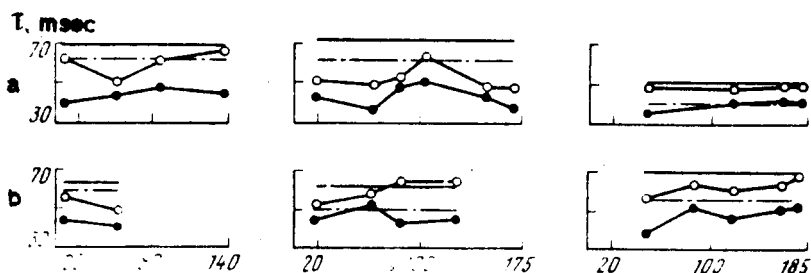

Figure 13: Changes over time in duration of isometric contraction phase ( ) of left cardiac ventricle in captains (a) and flight engineers (b) in response to LBNP on 140-, 175- and 185-day flights . Key: as in Figure 12

P622

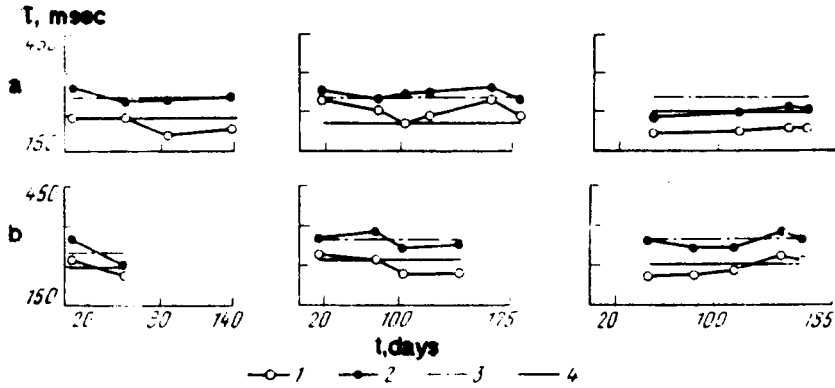

Figure 14: Changes over time in duration of ejection period ( $\tau$ ) of left cardiac ventricle in captains (a) and flight engineers (b) in response to LBNP on 140-, 175- and 185-day flights. Key: as in Figure 12

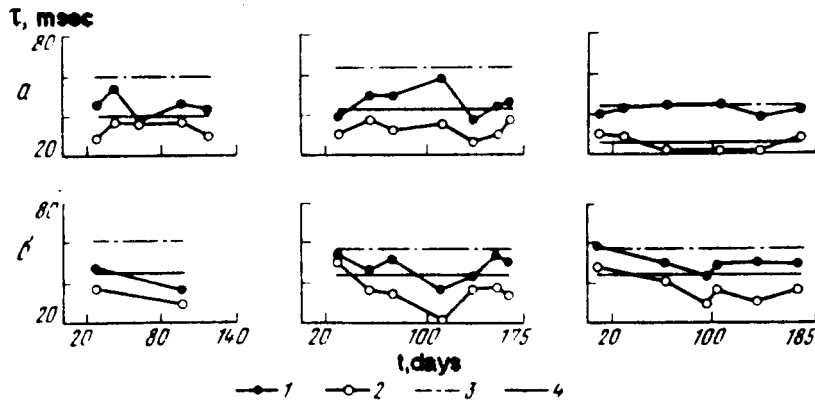

Figure 15: Changes over time in duration of isometric contraction phase ( $\tau$ ) of the left cardiac ventricle in captains (a) and flight engineers (b) in response to graded physical exercise during 140-, 175-, and 185-day flights  
 1 - in flight before test; 2 - during first minute after the test and during preflight period; 3 - before the test; 4 - in first minute after test  
 [sic.: key appears to be out of order]

P622

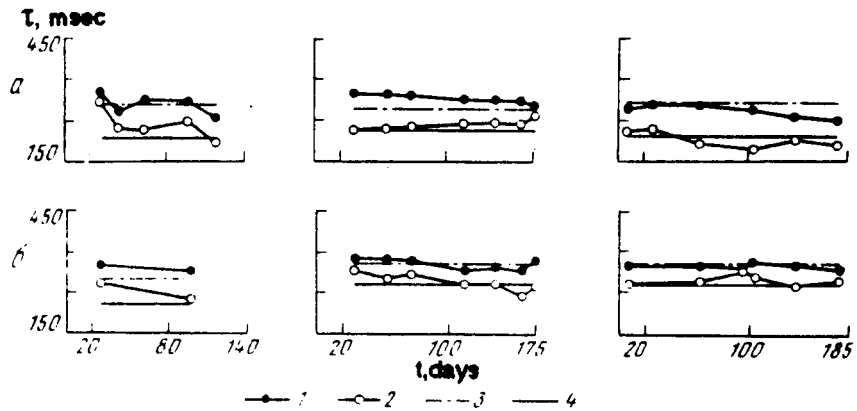

Figure 16: Changes over time in ejection period ( $T$ ) of left cardiac ventricle in captains (a) and flight engineers (c) in response to tests with graded physical exercise on 140-, 175- and 185-day flights. Key: as in Figure 15.

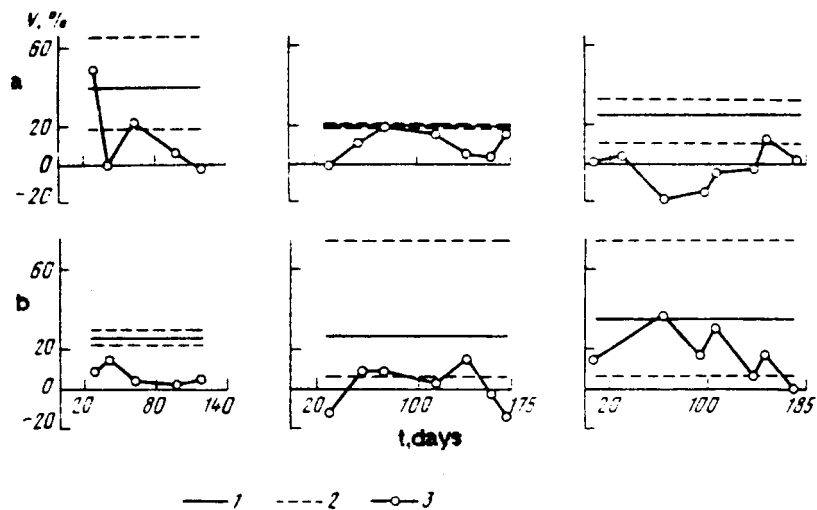

Figure 17: Changes in stroke volume of circulation in captains (a) and flight engineers (b) in the first minute after a test with graded physical exercise on 140-, 175-, and 185-day flights.

1 - preflight period, 2 - limits of preflight fluctuations, 3 - inflight

P622

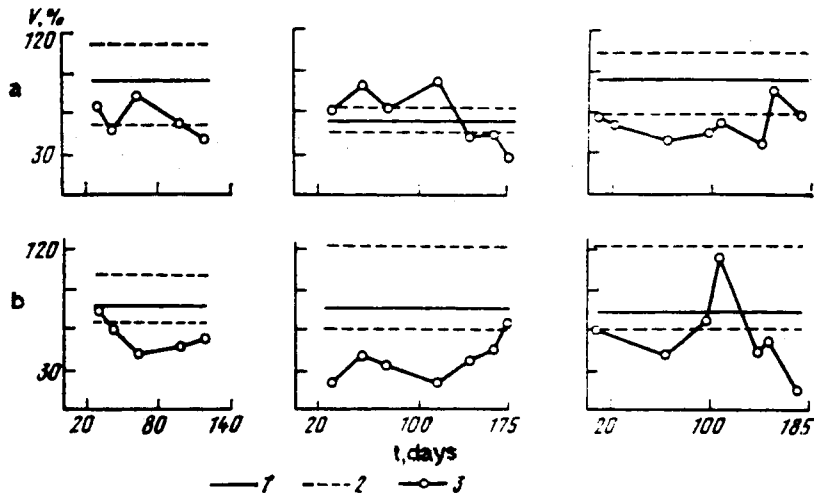

Figure 18: Changes over time in circulatory minute volume in captains (a) and flight engineers (b) during the first minute after a test with graded physical exercise on 140-, 175-, and 185-day flights. Key: as in Figure 17



## COSMONAUT TRAINING

(See also: Space Biology: M116)

### MONOGRAPH:

M115(14/87) Beregovoy GT, Grigorenko VN, Bogdashevskiy RB, Pochkayev IN, Kosmicheskaya Akademiya [Space Academy].

Moscow: Mashinostroyeniye; 1987.

[152 pages; 13 tables; 10 figures; numerous photographs; 113 references; 4 in English]

**KEY WORDS:** Cosmonaut Training, Personnel Selection, Psychology, Human Performance, Small Groups, Space Crews

**Annotation:** This book is devoted to an area of cosmonautics relatively unfamiliar to the general public; the selection, instruction, and psychological, flight, and engineering training of cosmonauts. Virtually all aspects of the cosmonaut training program developed over the past 25 years are covered. The book presents a clear description of how these specialists are educated and professionally trained. The authors cover the stages involved in becoming a cosmonaut, beginning with selection of prospective cosmonauts, through their general space and specialized training with a variety of special-purpose training devices. This book is intended for the general public.

### CONTENTS

(Numbers in parentheses refer to page numbers in the original.)

Foreword (5)

Introduction (6)

#### **Prospective Cosmonauts (11)**

Selection (11)

Features of psychological selection (16)

Principal psychological stress factors of space flight (18)

Principles, methods, and criteria in psychological selection (22)

#### **Day-to-day Life at the Academy (26)**

#### **The Making of a Cosmonaut (35)**

Anechoic chamber tests of cosmonauts'neuropsychological sensitivity (41)

Psychophysiological aspects of cosmonaut flight training(46)

Parachute training of cosmonauts (47)

Training cosmonauts in post-reentry operations (49)

#### **Psychological and Medical Conditioning (57)**

The influence of mission performance on cosmonauts' psychological characteristics (60)

Organizational and methodological fundamentals and the principles of medical and psychological conditioning (65)

Stages in medical and psychological conditioning (75)

M115

**Psychologists Create a Crew (82)**

Individual cognitive styles of cosmonauts (82)

Principles of crew selection (85)

Group psychological training (89)

The crew of a spacecraft (90)

**Professional Training(98)**

A word about the profession of cosmonaut (98)

Weightlessness and EVAs (99)

In the grip of acceleration (114)

With movie and television cameras (118)

**Simulator Training (121)**

General principles of trainer-based instruction (121)

Training conditions (128)

Monitoring and control (135)

Exams (141)

References (147)

## DEVELOPMENTAL BIOLOGY

(See also: Space Biology: CR7, M116, M117)

### PAPER:

P593(14/87)\* Krasnov IB, Olenev SN, Babichenko II, Kesarev VS.  
**Morphogenesis of the brains of rats developing in weightlessness.**  
Kosmicheskaya Biologiya i Aviakosmicheskaya Meditsina.  
21(4): 16-22; 1987.  
[20 references; 11 in English]

Developmental Biology, Morphogenesis; Neurophysiology, Brain; Endocrinology,  
Pituitary, Hypothalamus; Enzymology

Rats

Space Flight, Cosmos-1514

**Abstract:** This experiment studied the brains of rats exposed to space during days 13-18 of embryogenesis on "Cosmos-1514." Animals were sacrificed for study on day 18 of fetal development (decapitated 4-8 hours after reentry), immediately upon birth, or at 15, 30, or 100 days old. Synchronous and vivarium controls were used. The brains of all 18-day fetuses and 3 animals from each of the 15-, 30-, and 100-day old groups were subjected to macroscopic histological analysis. Brain tissue was fixed, sectioned, and stained. The hindbrains of the 18-day old animals in the 3 conditions were frozen, and 15  $\mu$ m sections prepared. Histochemical methods were used to determine the activity of  $\text{NAD}^+\text{H}_2$ - and  $\text{NADP}^+\text{H}_2$ -diaphorase, lactate dehydrogenase (LDH), succinate dehydrogenase (SDH), monoamine oxidase (MAO), acetylcholinesterase (ACE), and alkaline (ALP) and acidic (AcP) phosphatases. Intensity of reactions was measured with a cytophotometer. A teleanalyser was used to perform a quantitative analysis of the cytoarchitectonics of the cerebral neocortex in 18-day old fetuses. The width of the walls of the cerebrum and its layers were measured in 5 samples from each fetus. In subsets of each group, electron microscopy was used to examine the supraoptic nucleus and medial eminence of the hypothalamus, and the analogous structures in the posterior lobe of the pituitary.

The brains of 18-day-old fetuses and 15-, 30-, and 100-day-old rats in the flight group displayed no differences from those of control groups when examined visually and using an optical microscope. [The authors note that the reason for this lack of difference may be that the apparatus transmitting otolith stimulation to the brain develops after day 18 of embryogenesis.] No differences were found in the mitotic activity of neuroblasts and glial elements measured in the periventricular zone of the medulloblast matrix, nor in the dimensions of the neurons of trigeminal nerves. However, fetuses in the flight group did display significantly more capillaries per unit area in striatum cross-sections than control fetuses. The authors hypothesize that this is the result of insufficient oxygenation due to decreased placenta size in flight group mothers.

Histochemically, flight rats displayed no abnormalities in the intensity and location of activity of most enzymes measured. However, there was a decrease in alkaline phosphatase activity in the endothelium of capillaries in the hindbrain, indicating decreased rate of transport of metabolites from the capillaries to the nerve tissue. Qualitative analysis of the neocortices of 18-day-old fetuses revealed no differences between flight and

P593

control groups. Quantitative measurements revealed a tendency for the neocortex layer to be narrower in both flight and synchronous groups, suggesting a tendency for the migration of cellular elements from the matrix to the cortical layer to be retarded. The supraoptical nucleus and medial eminence of the hypothalamus in flight rats showed ultrastructural evidence of delay in the development of neurosecretor cells at the neuroblast stage. This is attributed to humoral factors. However, data from neonate rats in the flight group indicate a tendency for these differences to normalize during subsequent ontogenesis on Earth. The posterior lobes of pituitary glands of neonate rats of the flight and synchronous groups display hypertrophy and vesicularization of the elements of the laminar complex, increased number of tubules in the rough endoplasmic network and free ribosomes, lightening of the mitochondrial matrix and pronounced condensation of chromatin in the nuclear membrane, testifying to increased activity of these cells. The authors argue that the cause of this phenomenon is different for the flight and experimental groups. Ultrastructure of the pituitary and hypothalamus of animals in the flight group had normalized by day 15 of postfetal development.

Table 1: Activity of enzymes in nerve tissue of the hindbrain of 18-day-old rat fetuses

Condition	Lactate Dehydrogenase units of optical density on optical probe area		Alkaline Phosphatase units of optical density on optical probe area	
Vivarium	186		565	
Synchronous control	191		659**	
Flight	180		846*, ***	

\* p < 0.001 compared with vivarium control

\*\* p < 0.05 compared with vivarium control

\*\*\* p < 0.05 compared with synchronous control

Table 2: Width of the layers of the cerebral walls of 18-day-old fetuses

Structure	Absolute width, um			Relative width, %		
	Vivar.	Flight	Synch.	Vivar.	Flight	Synch.
Marginal zone	23.0	22.7	27.5	6.6	6.4	6.6
Cortical layer	115.3	100.2	118.1	32.7	28.2	28.1
Interstitial layer	125.2	117.4	131.8	35.5	33.1	31.4
Matrix	88.9	114.4	142.4	25.2	32.2	33.9*
Cerebral wall	352.4	354.7	419.7	100	100	100

ORIGINAL PAGE IS  
OF POOR QUALITY

P593

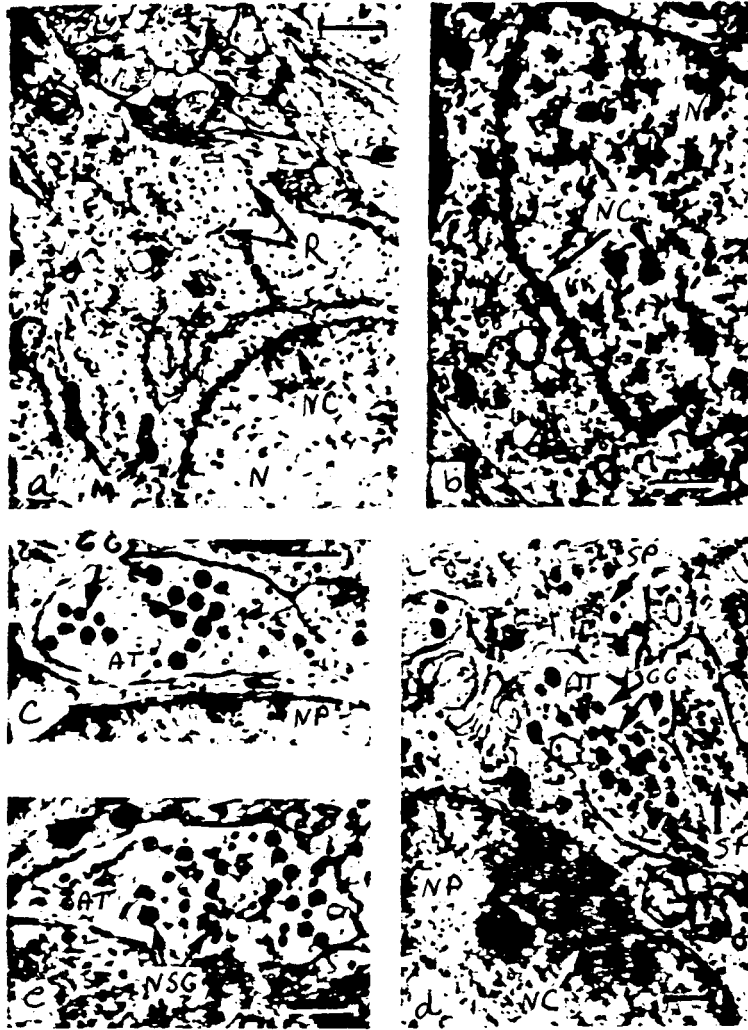

Figure: Ultrastructure of bodies and axon terminals of neurosecretory neurons of the supraoptical nuclei of the hypothalamus of 18-day-old fetuses and neonate rats

a and b - neurosecretory neurons of supraoptical nuclei of 18-day-old rat fetuses in vivarium and flight groups, respectively. Mag. 9000. Scale: 1  $\mu$ m; c, d, and e - axon terminals of neurosecretory neurons of supraoptical nuclei in the posterior lobe of the pituitary of neonate rats in the vivarium, flight and synchronous groups, respectively. Mag. 17,000, 16,000, and 18,000. Scale: 0.5  $\mu$ m. N - nucleus of neurosecretory neuron; NP - pituicyte nucleus, NC - chromatin nucleus, AT - axon terminal; SF - synaptic follicles, NSG - neurosecretory granules; GG - granular neurosecretory granules, M - mitochondria, R - ribosome.

## ENDOCRINOLOGY

(See also: Developmental Psychology: P593; Enzymology: P616;  
Neurophysiology: P621; Space Biology: P592)

### PAPERS:

P608(14/87)\* Pribylova NN.

**The effect of steroid hormones on the level of biogenic amines in the lungs during the development of pulmonary hypertension in rats under conditions of chronic hypobaric hypoxia.**

Kosmicheskaya Biologiya i Aviakosmicheskaya Meditsina.

21(4): 76-78; 1987.

[16 references; 1 in English]

Endocrinology, Steroid Hormones, Biogenic Amines; Cardiovascular and  
Respiratory Systems, Pulmonary Hypertension  
Rats  
Hypoxia, Hypobaric, Chronic

**Abstract:** Experiments were performed on male white rats. Chronic hypoxia was induced in a barochamber, where rats were exposed to an altitude equivalent of 9000 m (air pressure = 220 mm HG) for 6 hours per day for 7 days. This treatment is known to create pulmonary hypertension and pulmonary decompensation. The rats were divided into 10 groups of 12-15 animals. Animals in 4 of the experimental groups were injected daily with hydrocortisone, testosterone propionate, or progesterone in concentrations of 1 mg per 100 g body weight, or 0.1 mg per 100 g body weight of estradiol dipropionate. Four other groups received the same injections but were not exposed to hypoxia. One group was exposed to hypoxia but not given steroids, and one group received neither steroids nor hypoxia. Concentrations of epinephrine, norepinephrine, histamine and serotonin were measured in homogenized lung tissues.

Chronic oxygen deficit led to increased concentrations of serotonin (by a factor of 2.5), histamine (factor of 5.5), epinephrine and norepinephrine (factor of 2). Administration of steroid hormones to rats undergoing chronic hypobaric hypoxia, inhibited increase in vasopressor biogenic amines, norepinephrine, and serotonin. Hydrocortisone was most effective in inhibiting serotonin, while sexual steroids had a moderate inhibiting effect. Estradiol led to a moderate increase in serotonin in rats not exposed to hypoxia. Steroids, especially hydrocortisone and progesterone, inhibited formation of histamine in both hypoxic and control animals. Estradiol had the least effect. Under normal oxygenation, all steroid hormones increased epinephrine activity. Under hypoxia these hormones depressed norepinephrine. The authors conclude that steroid hormones play an important role in biogenic amine metabolism under normal and especially hypoxic conditions. Steroid hormones tend to decrease formation of vasopressor biogenic amines that constrict pulmonary vessels. Inactivation of these amines in lung tissue induced by progesterone and hydrocortisone should be considered in the treatment of pulmonary hypobaric hypoxia.

**Table:** Concentration of biologically active substances in pulmonary tissue of white rats exposed to chronic hypoxia in response to administration of steroid hormones

P618(14/87) Arefolov VA, Malikova LA, Val'dman AV.

**Morphometric study of the ultrastructure of cells containing epinephrine and norepinephrine in the adrenal glands of rats subjected to immobilization stress varying in duration.**

Byulleten' Eksperimental'noy Biologii i Meditsiny.

CIII(6): 743-746; 1987.

[8 references; 2 in English]

Affiliation: Institute of Pharmacology, USSR Academy of Medicine, Moscow

Endocrinology, Adrenal Glands; Cytology and Morphology, Cell Ultrastructure  
Rats

Psychology, Immobilization Stress

**Abstract:** This experiment studied the quantity of chromaffin granules containing epinephrine and norepinephrine in cells of the adrenal cortex, and also performed a morphometric analysis of the redistribution of these structures after immobilization stress varying in duration. Subjects were male rats immobilized by harnessing them to special stands for 3, 14, and 48 hours. After this treatment, animals were sacrificed and the adrenal cortex removed and fixed. A method (not described) was used whereby epinephrine- and norepinephrine-containing cells could be differentiated in a single image. Morphometry was applied to electron microscopic images to determine the number of epinephrine- and norepinephrine-containing granules in a unit area of cytoplasm. Ultrastructural changes were examined on 30 images of each type of cell.

Electron microscopy and cytochemical analysis of the medullary substance of the adrenal glands indicated 3 types of secretory granules: vesicles full, or partially full of products of cytochemical reactions; and those which were empty. In control animals, the majority of structures (50-60%) were full, 30% were partially full, and 15% were empty. During the first 3 hours of immobilization (the "anxiety" stage), number of full epinephrine-containing granules decreased to 76% of control, while partially full granules increased by 43% over control. Changes in norepinephrine cells were less pronounced. During the "resistance" stage of immobilization stress, the number of empty vesicles increased by a factor of 2 compared to controls. The number of partially-full epinephrine-containing granules remained elevated for this period, while number of vesicles partially full of norepinephrine was unchanged. After 48 hours of immobilization stress (exhaustion stage), depletion of chromaffin granules continued to develop, number of full epinephrine- and norepinephrine-containing cells was 21 and 26% of control levels, respectively, while empty granules increased by a factor of 4.

P618

Table: Distribution of epinephrine- and norepinephrine-containing secretor granules in chromaffin cells of adrenal glands in rats exposed to immobilization stress varying in duration

Stress reaction	Immob. duration hours	Epinephrine-containing			Norepinephrine-containing		
		Full	Part full	Empty	Full	Part full	Empty
Norm	0	52.4	32.2	15.4	64.0	23.1	13.0
Anxiety Stage	3	40.0*	46.1*	13.9	59.1	25.2	15.7*
Adaptation Stage	24	27.7*	46.6*	25.7*	24.8*	25.8	49.4*
Exhaustion Stage	48	11.0*	28.9	60.1*	16.8*	33.6*	49.6*

\*: Differs significantly,  $p < 0.05$  from norm

Figure 1: Electron-microscopic identification of epinephrine- and norepinephrine-containing granules in chromaffin cells of the adrenal glands of rats subjected to immobilization stress varying in duration

Figure 2: Histogram of distribution of numbers of secretor granules in epinephrine- and norepinephrine-containing cells in adrenal glands of rats subjected to immobilization stress varying in duration



## ENZYMOLGY

(See also: Developmental Biology: P593; Metabolism: P613; Space Biology: M592, CR7, M113)

### PAPERS:

P616(14/87) Komarin AS, Azimova ShA.

**The state of the monooxygenase enzymatic system in liver tissue of rats undergoing hypokinesia.**

Voprosy Meditsinskoy Khimii.

33(4): 75-78; 1987.

[22 references; 3 in English]

Affiliation: Central Research Laboratory, Tashkent Medical School

Enzymology, Monooxygenase System, Liver

Rats

Psychology, Immobilization Stress; Endocrinology, Adrenalectomy

**Abstract:** In this experiment, rats in group 1 were kept in immobilization cages. Rats in group 2 were adrenalectomized and then placed in the cages. Group 3 rats were adrenalectomized and then allowed free movement. All surgical procedures involved in an adrenalectomy with the exception of removal of the gland, were performed on group 4 rats which were then placed in immobilization cages. Group 5 rats underwent the false adrenalectomy and then were kept under free movement conditions. After 1, 3, 7, 10, 20, and 30 days, some of the animals in each group were sacrificed and the microsome fraction of the liver extracted through centrifugation. Activity of aminopyrine demethylase, aniline hydroxylase, and NADPH - cytochrome c-reductase were determined; concentrations of cytochrome P-450 and  $b_5$ , and microsome protein were measured.

Definite phases were observed in the changes in microsome enzymes and cytochrome in rats undergoing hypokinesia. After 1 day of hypokinesia, concentrations of P-450 and  $b_5$  and activity of aniline hydroxylase and NADPH-cytochrome reductases increased. On day 3, no statistically significant changes from baseline were noted. Subsequently, significant inhibition of monooxygenase enzyme activity in the liver was noted. Adrenalectomy was associated with a significant decrease in the activity of microsome enzymes and cytochromes on day 1, which grew steadily greater throughout the hypokinesia period. The combination of the two treatments was not associated with significant differences from adrenalectomized rats on either day 1 or 3 in any of the parameters measured. However, starting on day 7, rats receiving both treatments showed increasingly greater signs of inhibition of the monooxygenase enzyme system of the liver than rats which were only adrenalectomized. The false adrenalectomy procedure did not affect the parameters studied. The authors conclude that, initially, stress is the major factor in the effects of hypokinesia on the detoxification function of the liver. Subsequently, lack of movement is the key factor.

Table 1: Activity of microsome enzymes and concentration of cytochromes P-450 and  $b_5$  in rats livers at various points during exposure to hypokinesia

Table 2: Activity of microsome enzymes and concentration of cytochromes P-450 and  $b_5$  in livers of rats exposed to hypokinesia and subjected to adrenalectomy or false adrenalectomy

P620(14/87) Kurtser BM, Zor'kina TA.

**Changes in succinic dehydrogenase and cytochrome oxidase activity in the myocardium and brain of rats exposed to hypokinesia.**

Patologicheskaya Fiziologiya i Eksperimental'naya Terapiya.

1987(1): 11-13.

[11 references; 1 in English]

Authors' affiliation: Kishinev Medical Institute

Enzymology, Succinic Dehydrogenase, Cytochrome Oxidase, Brain, Myocardium  
Rats

Immobilization

Abstract: Subjects in this experiment were 50 male white rats, of which 10 served as controls. The remaining animals were placed in immobilization cages for 5, 10, 15, or 28 days, after which they were sacrificed and the brains and myocardia isolated for study. Concentration of succinic dehydrogenase (SDH) was measured using neotetrazol and was expressed in picomoles diphormazan (glyoxal) forming in 1 second in 1 g fresh tissue. Cytochrome oxidase (Cyt. O) was measured with indophenol and expressed in nanomoles indophenol forming in 1 second in 1 g fresh tissue.

In control rats, SDH activity was greater in the brain and Cyt. O in the myocardium. In experimental rats, activity of SDH in the brain decreased with duration of hypokinesia, and on day 28 was 45.8% of control level. Cyt. O activity in the brain was elevated on day 5 of immobilization and then began to drop, reaching 25.2% of control level on day 28. In the myocardium, SDH activity was slightly elevated on days 5 and 10 of hypokinesia and then decreased sharply, reaching 31.9% of control, while Cyt. O activity decreased gradually throughout, finally reaching 26% of control. The authors argue that these changes may be explained by the accumulation of free unutilized corticosterone in the organs studied.

Table: SDH and Cyt. O activity in the brain and myocardium of rats exposed to hypokinesia

**GASTROINTESTINAL SYSTEM**

(See also: Space Biology: P592)

**PAPER:**

P605(14/87)\* Liz'ko NN, Goncharova GI.

**Use of bifidobacterin to correct intestinal bacteriosis.**

Kosmicheskaya Biologiya i Aviakosmicheskaya Meditsina.

21(4): 70-72; 1987.

[4 references; none in English]

Gastrointestinal System, Intestinal Flora

Humans, Cosmonauts

Isolation, Countermeasures, Bifidobacterin, Hypokinesia, Head-down Tilt

**Abstract:** Long-term isolation, including space flight, has been found to engender intestinal dysbacteriosis. Bifidoflora play an important role in supporting normal microbiocenosis in the intestine, preventing the pathogenic effects of a number of microbes, and increasing resistance to infection. To test the effects of administering preparations of bifidobacterin on intestinal microflora of humans living in isolation, two subjects spent 7 days in a hermetically sealed room with temperature of 35°C, humidity of 90%, and CO<sub>2</sub> concentration of 3.7%. One subject was given a preparation of bifidobacterin and the other was not. In the first subject, concentrations of bifidobacteria increased, while concentrations of lactobacteria and intestinal bacilli decreased. In the control subject, bifidoflora and lactoflora decreased by a factor of 10, while concentration of potentially pathogenic enterobacteria increased. A 14 day experiment with analogous conditions had similar results. Bifidobacterin also had salutary effects on the intestinal microflora of individuals recovering from a 182-day period of hypokinesia and head-down tilt. Bifidobacterin in tablet form has also been used effectively on 8 cosmonauts on long- and short-term flights (details not specified). Seven additional cosmonauts were found to have lowered levels of bifidoflora during training and were given a product of milk soured with bifidobacteria. This preparation was found to be effective in restoring intestinal microflora. Bifidobacteria have also been successfully added to dried fruit juice and lyophilized cheeses. The bacteria have been shown to be viable when the products are stored for 3-5 years and do not alter the taste of the products.

Table: Normalizing effects of bifidobacterin on intestinal microbiocenosis

**HEMATOLOGY**

(See also: Adaptability: P617; Space Biology: P590)

P598(14/87)\* Gladilov VV, Moyseyenko NA.

**Acid-base balance and other blood parameters in rats after exposure to hyperbaric oxygenation.**

Kosmicheskaya Biologiya i Aviakosmicheskaya Meditsina.

21(4): 41-45; 1987.

[12 references; 1 in English]

Hematology, Acid-Base Balance, Oxygen Affinity

Rats

Hyperbaric Oxygenation

**Abstract:** This study attempted to identify changes in the acid-base balance of blood and other associated parameters after exposure to hyperbaric oxygenation in a barochamber. Atmosphere in the barochamber was 99% oxygen. Rats of both sexes (number not specified) were placed in the barochamber at 2026 gigaPa for 15, 30, or 60 minutes, spent 10 minutes under normal air pressure and then were sacrificed. Mixed arterial and venous blood was studied. Parameters associated with acid-base balance were measured with a microanalyzer; and affinity of hemoglobin for oxygen with partial pCO<sub>2</sub> of 40 mm Hg, temperature of 37° C and pH of phosphate buffer solutions of 7.2 and 7.6, were measured spectrophotometrically. Other parameters studied were concentration of 2,3-diphosphoglycerine acid (2,3-DPG), concentration of glucose, aldolase activity, concentration of reticulocytes, hemoglobin heterogeneity, and electrophoretic mobility of individual fractions of hemoglobin. A control group of animals housed in the barochamber under normal atmospheric conditions was studied for comparative purposes.

Noticeable changes occurred after 15 minutes of exposure to the oxygen medium. Acid-base parameters pointed to development of alkalosis of the blood. At the same time, the concentration of 2,3-DPG decreased by 15%, and the electrophoretic mobility of all blood fractions decreased significantly. After 30 minutes of exposure, acid-base parameters, with the exception of pCO<sub>2</sub>, did not differ from control level; 2,3-DPG was further reduced (68%). Aldolase activity decreased by 61% and glucose concentration increased by 30%. These changes imply inhibition of glycolysis in erythrocytes and development of stress. The biochemical changes in erythrocytes were accompanied by changes in electrophoretic mobility: fractions 1 and 2 increased; 3 and 4 remained the same, while all the others continued to increase. Two additional minor components appeared. None of these changes, however, altered the affinity of hemoglobin for oxygen. Exposure to hyperbaric oxygenation for 60 minutes led to normalization of the majority of parameters measured. Statistically significant differences did occur in the concentration of 2,3-DPG and in the electrophoretic mobility of most hemoglobin fractions (pattern identical to 30-minute exposure). Only after exposure for this duration did affinity for oxygen change (16% increase). In addition, dissociation curves were displaced to the left and p50 decreased by more than 5 mm HG. All the changes described occurred in erythrocytes circulating in the vascular bed. Erythrocyte concentration increased by 19% after 30 minutes of hyperbaric oxygenation and virtually normalized after 60 minutes. Reticulocyte concentration decreased from 33% under normal

P598

conditions to 12.5% after 60 minutes of hyperbaria. No changes in dissociation curves occurred after 15 and 30 minutes of hyperbaria; however, after 60 minutes affinity increased substantially, dissociation curves were displaced to the left and p50 values decreased for most subjects. Magnitude of the Bohr effect was identical in the control and all the experimental conditions.

The authors conclude that relatively short exposure to hyperbaric oxygenation in rats, leads to altered affinity of hemoglobin for oxygen (mediated by a set of biochemical changes in blood plasma and erythrocytes which occur as a consequence of altered acid-base balance) to altered affinity of hemoglobin to oxygen. This alteration is relatively stable and persists for some time after the treatment has terminated. The displacement of dissociation curves to the left has important implications for tissue oxygen supply in the period immediately following hyperbaria. The fact that the majority of parameters behave differently as a function of duration of hyperbaria may explain contradictory data in the literature.

Table 1: Changes in blood parameters in rats as a function of duration of hyperbaric oxygenation

Table 2: Changes in electrophoretic mobility of Hb fractions as a function of duration of hyperbaric oxygenation

**HUMAN PERFORMANCE:** Cosmonaut Training: M115; Metabolism: P613; Space  
Biology: CR7, M117

### **IMMUNOLOGY**

(See also: Radiobiology: P611)

P602(14/87)\* Mukhamedyeva LN, Konstantinova IV, Zhuravlev VV.

**Physiological and immunological aspects of human adaptation to heat in a hermetically sealed environment.**

Kosmicheskaya Biologiya i Aviakosmicheskaya Meditsina.

21(4): 60-64; 1987.

[22 references; 6 in English]

Immunology; Adaptation

Humans

Sealed Environment, Heat, Humidity

**Abstract:** This experiment involved exposure to heat. In one experimental condition (III), 17 healthy adults spent 15 days in a hermetically sealed environment of which 7 days were spent in a microclimate with temperature of 33° C, relative humidity of 90% and barometric pressure of 750 mm Hg, with an atmosphere containing 20% oxygen and 0.4-0.6% carbon dioxide. In a control condition (I) 4 individuals were exposed for 15 days to a microclimate identical except for temperature, which was maintained at 20° C. In a second control condition (II), microclimate was identical to that of group III, with the exception of humidity which was maintained at 40%. Exposure to heat in this condition lasted 15 days. Thermal status of the subjects was assessed on the basis of rectal temperature and skin temperature measured at 11 body locations. Blood parameters measured included activity of catalase, level of sodium in serum, and acid-base balance of whole blood. Immunological investigations used venous blood from the cubital vein. Lymphocytes were separated from peripheral blood and the quantity of T-lymphocytes determined by the method of spontaneous rosette formation with sheep erythrocytes (E-ROC). Level of B-lymphocytes was evaluated on the basis of rosette formation with bull erythrocytes, loaded with M-antibodies and the third complement components, EAC-ROC. The functional state of the total population of T-lymphocytes was evaluated radioautographically. Functional activity of B-lymphocytes was assessed on the basis of A, M, and G immunoglobulin level. Allergic status was evaluated using the method of specific blast transformations of lymphocytes in vitro in the presence of bacterial allergens representing human automicroflora. Allergic response to formalin, epichlorine, and pyridine were also examined.

In the control condition (I), no changes were noted in any parameter with the exception of some decrease in basal metabolism, typical of exposure to hermetically sealed environments. In condition II, subjects described the microclimate as "warm" and complained of a feeling of stuffiness at night. Mean body temperature increased by 0.3° C which was attributable to skin temperature. No immunological effects were noted. In condition III, with elevated humidity as well as heat, subjects described the microclimate as hot. On the first day rectal temperature increased by 0.6° and mean skin temperature by 1.8°. Body heat content was estimated to increase by a mean of 41.5 cal/m<sup>2</sup>/hr, evidently as a result of accumulation of metabolic heat due to decrease in physiological moisture deficit. The greatest increase in

P602

heat occurred during the first day of exposure to the microclimate. Thermal conditions also decreased the skin temperature gradient at different points on the body. Subjects complained of tiring easily, insomnia, a feeling of heaviness in the head, and loss of appetite. On day 2 or even before, subjects developed an itchy rash which turned to abscesses and 2 subjects developed conjunctivitis. Compensatory metabolic acidosis developed on day 1. On or before day 7, catalase activity of blood decreased and concentration of sodium increased. E-ROC was elevated compared to baseline on days 2, 5-7, 10-13 under experimental conditions. Increased concentration of EAC-ROC was observed on days 5-7. Concentrations of IgG on days 5-7, and of IgA on days 10-13 were significantly above baseline. No changes were observed in the functional activity of T-lymphocytes. No changes were seen in allergenic sensitivity, nor in sensitivity to normal human automicroflora. Changes in immunological parameters paralleled the development of skin eruptions. Soon after subjects emerged from the overheated environment, dermatological symptoms disappeared and immunological parameters normalized. Although no direct effects on allergic responses were observed, the authors argue that increased levels of immunoglobulins suggest that the overheated environment led to increased sensitivity to autoantibodies which in turn had a role in the skin problems.

Table 1: Experimental conditions

Table 2: Change in immunological parameters in group III

P610(14/87)\* Kitayev MI, Goncharov AG.

**Mononuclear phagocytes in high altitude adaptation of healthy individuals.**

Kosmicheskaya Biologiya i Aviakosmicheskaya Meditsina.

21(4): 80-82; 1987.

[12 references; 3 in English]

Immunology, Mononuclear Phagocytes

Humans, Males, Individual Differences

Adaptation, High Altitude

**Abstract:** The mononuclear phagocyte system was assessed in 51 male subjects, aged 18-22, undergoing adaptation to high altitude. The first set of measurements were made at the starting altitude of 1543 m, and the next two on days 3-5 and 25-30 of adaptation to an altitude of 3600 m. Subjects were divided into two groups on the basis of how well they were adapting. Group 1 included 33 subjects adapting well, while group 2 subjects (N=18) developed symptoms of acute altitude sickness lasting 3-5 days or more. A group of men who had lived all their lives at 3600 meters served as controls. State of the monocular phagocyte system was assessed using monocyto grams, by determining the phagocytic activity of monocytes in blood with latex particles, and counting EAC-ROC and E-ROC monocytes.

In individuals adapting well, there were only slight increases in absolute and relative concentrations of monocytes after ascent, which subsequently decreased sharply on days 25-30 of adaptation, but remained above that of high altitude residents. Those with symptoms of altitude sickness showed no statistically significant changes in monocytes. However, their initial level was significantly lower than that of successful adapters. Monocyto grams of both groups showed a tendency for proliferative activity and the index of differentiation to increase toward the end of the adaptation period. In both groups of subjects the number of monocytes phagocytizing latex decreased sharply as exposure to high altitude increased. This parameter remained higher in the good adapters than in the bad. The level of this parameter in both experimental groups remained higher than in permanent residents. The relative concentration of monocytes carrying C3- and Fc-receptors decreased in the successful adapters on days 3-5 and increased on days 25-30, remaining below baseline; absolute level of these cells decreased throughout the period. In individuals suffering from altitude sickness, relative and absolute amounts of cells with Fc receptors decreased, while the level of cells with C3 receptors remained the same. During the baseline period concentration of rosette forming cells was lower in subjects who later developed altitude sickness. Both adapting groups had higher levels of ROC than permanent residents of high altitudes.

Figure 1: Level of monocytes in individuals successfully adapting to high altitudes or developing acute high altitude sickness and in permanent residents of high altitudes

Figure 2: Level of monocytes phagocytizing latex in individuals successfully adapting to high altitudes or developing acute high altitude sickness and in permanent residents of high altitudes



P610

Figure 3: Level of monocytes forming EAC rosettes in individuals successfully adapting to high altitudes or developing acute high altitude sickness and in permanent residents of high altitudes

Figure 4: Level of monocytes forming EA rosettes in individuals successfully adapting to high altitudes or developing acute high altitude sickness and in permanent residents of high altitudes

P623(14/87) IV Konstantinova.

**Immunological research [on "Salyut-6" prime crews].**

In: Gurovskiy NN, editor.

Rezultaty Meditsinskikh Issledovaniy Vypolnennykh na Orbital'nom Nauchno-issledovatel'skom Komplekse "Salyut-6" - "Soyuz"

**[Results of Medical Research Performed on the "Salyut-6"- "Soyuz" Space Station Complex.]**

Moscow: Nauka; 1986: 114-124. See Digest Issue 13: Space Medicine: M112 [25 references; 16 in English]

Immunology, Epidemiology, Immunological Reactivity, T-lymphocytes,  
Immunoglobulin  
Humans, Cosmonauts  
Space Flight, Long-term, Salyut-6

Abstract: Immunological studies of Salyut-6 prime crews fall into 3 groups: 1) preflight examinations of the crews, including epidemiological studies; 2) study of immunological reactivity postflight; 3) determination of immunoglobulin concentrations in the blood during flight. Epidemiological investigation included analysis of blood serum for presence of Australia antigen, analysis of nasal mucous, and evaluation of immunological parameters indicative of the initial latent period of viral infections in the cosmonauts' blood. None of these studies revealed changes characteristic of virus carriers, the prodromal stage of viral hepatitis, or disease caused by influenzal infections.

Cosmonauts were studied immunologically during the training period, 30-45 days and 1 week before launch, on day 1 postflight and later in the postflight period. The functional activity of T-lymphocytes evaluated in vitro on the basis of rate of RNA synthesis after contact with a mitogen on day 1 postflight had decreased in 7 of 10 cosmonauts studied. This parameter had normalized after a week in all cosmonauts studied. Proliferative activity of T-lymphocytes remained unchanged in all but two crewmembers. A subpopulation analysis of lymphocytes showed a decrease in T-lymphocytes after long flights in 8 of 10 subjects. This parameter dropped further in the postflight period in 9 subjects, but had normalized after a week in some subjects. In one subject normalization had not occurred 1 month postflight. Subpopulation of active T-cells in T-lymphocytes was unchanged in 8 of 10 subjects, and elevated in the rest. In 2 of 4 cosmonauts studied total concentration of B-lymphocytes had decreased significantly 1 day postflight. B-lymphocyte subpopulation was diminished in 2 subjects. Concentration of lymphocytes with receptors to Fc-fragment of immunoglobulin remained within normal limits.

Reactivity of T-suppressors and T-helpers were studied in two crews. A tendency was noted for T-suppressors to be elevated postflight, while T-helper activity was diminished in 3 of 4 cosmonauts.

Study of the three major classes of immunoglobulins in the blood postflight had the following results. Some cosmonauts displayed significant changes in G- and A-immunoglobulin. In 2 of 10 subjects, G-immunoglobulin decreased significantly postflight and in 2 others tended to decrease. One subject showed decreased IgA, and 3 increased IgA postflight. No changes were observed in IgM.

P623

Autoimmune tests (rheumatoid factor and antibody titer to denatured DNA) were negative in the majority of cases pre- and postflight. Four of 8 cosmonauts showed a positive allergic reaction (3 to streptococcus and 1 to formaldehyde) postflight which was absent preflight. There was no evidence of allergic reactions to substances in the spacecraft cabin.

Immunoglobulins were studied during space flight in two crews. Some evidence of increased IgA or IgM was found for different crewmembers at some points in the flight.

The authors consider changes in the T-lymphocyte system to be the most stable and important immunological result of long-term space flight. They hypothesize that decreased concentration and PHA reactivity of T-lymphocytes after space flight may be caused by transfer of a portion of the T-lymphocytes into bone marrow, which has been observed in response to stress.

## LIFE SUPPORT SYSTEMS

(See also: Space Biology: M116)

### PAPERS:

P600(14/87)\* Dmitriyev MT, Malysheva AG, Rastyannikov YeG.

#### **Specific organic compounds in human wastes.**

Kosmicheskaya Biologiya i Aviakosmicheskaya Meditsina.

21(4): 50-56; 1987.

[15 references; 4 in English]

Life Support Systems, Organic Compounds  
Equipment and Instrumentation, Chromatomass Spectrometer, Computer  
Human Wastes

**Abstract:** This paper describes a study in which human waste products were analyzed using a GC mass spectrometer and a computer-based data processing system. The use of a computer in the data collection and processing is essential because of the number of components of human waste and the complexity of their interrelationships. Sampling and concentration of specific organic compounds in human wastes was accomplished on a polymer sorbent -- tenax (poly-2,6-diphenyl-p-phenyloxide). This material has many advantages over commonly used absorbents, chief of which are high thermal stability and moderate absorptive activity (allowing quantitative desorption from its surface at 280-300° C of carbohydrates up to octadecane), chemical inertness to the majority of organic compounds and water repellency. A total of 56 healthy individuals acted as subjects. Waste products studied included exhaled air, intestinal gas, urine, saliva, perspiration, and feces. Specific organic compounds were extracted from liquids and feces by gas extraction. A glass capillary chromatographic column 0.3 mm in diameter and 38 m long processed with silicon was used for gas chromatographic separation. The initial 5 minutes of chromatography occurred at room temperature. Then the temperature of the column was increased at a rate of 5°C per minute to 150°C. Compounds recorded on the chromatogram were identified with the help of a mass-spectra catalog and a computer library of spectra. The chief advantage of the computer GC mass-spectrometric method is the unique identification of compounds, which is especially important in studying such complex mixtures of hundreds of substances, such as human wastes.

Products identified could be classified as saturated hydrocarbons, unsaturated hydrocarbons, naphthenic hydrocarbons, aromatic hydrocarbons, oxygen-containing compounds (aldehydes, ketones, alcohols, esters), nitrogen-containing compounds, sulphur-containing compounds, and chlorine-containing compounds. The authors consider it of interest that human wastes contain significant quantities of oxygen-containing compounds, (acetaldehyde, hexanal, pentanol, octanal, heptanal, nonanal, benzaldehyde), ketones (methyl ethyl ketone, acetone, 2-butanone, 4-heptanone), alcohols (ethanol, methanol, isopropanol), esters (ethyl acetate, butyl acetate, 1,4-dioxane) and also formic acid, p-cresol, and phenol. The sulphur-containing compounds found in significant quantities included dimethyl disulphide, and the chlorine-containing compounds - chloroform, methyl chloride, the nitrogen-containing ones -- methylamine, isopropylamine, the aromatic hydrocarbons - benzol, toluol, xylol, the unsaturated hydrocarbons-- isoprene, ethylene,

P600

butylene, and the saturated hydrocarbons -- methane, ethane, and propane. The authors argue that the data obtained can be used for predicting the concentration of toxic metabolites in the atmosphere of hermetically sealed environments and for biomedical evaluation. Quantitative toxicology may be used to determine integrated air pollution indices for such environments. Since polymers and other construction materials will be continually improved for use in spacecraft, their contribution to internal air pollution will decrease. Thus pollution from human and animal wastes will become increasingly important.

Table: Excretion of specific organic compounds into the atmosphere

Figure: Fragments of computer chromatogram of specific organic compounds excreted by the body into the atmosphere with urine and feces

P601(14/87)\* Savina VP.

**Changes in functional parameters of animals in response to prolonged inhalation of acetic acid.**

Kosmicheskaya Biologiya i Aviakosmicheskaya Meditsina.

21(4): 56-60; 1987.

[16 references; 1 in English]

Life Support Systems, Physiological and Behavioral Effects

Mice, Rats

Hermetically Sealed Environments, Acetic Acid, Toxicology, Inhalation

**Abstract:** Acetic acid is a constant component of the atmosphere of hermetically closed environments, but its toxicology has not been sufficiently studied. Rats and mice were confined in chambers with volumes of 200 l. Air was blown through the chamber at a rate of 3.5 m<sup>3</sup>/hr. Air temperature was maintained within the limits of 24-27° C, and relative humidity ranged between 75-85%. Control animals were housed under identical conditions but not exposed to acetic acid. Seven trials were conducted with the following concentrations of acetic acid: 86 mg/m<sup>3</sup> (3 days), 75 mg/m<sup>3</sup> (2 trials of 17 days each and 1 of 35 days); 56 mg/m<sup>3</sup> (35 days); 35 mg/m<sup>3</sup> (22 days), 27 mg/m<sup>3</sup> (22 days). In addition, a number of 1- and 2-day trials were performed with acetic acid concentration of 400 to 900 mg/m<sup>3</sup> and 4-5 hour sessions with concentration from 10 to 30 mg/m<sup>3</sup>. Behavioral responses were studied using a modified "open field" test. Summation of contraction threshold was determined with impulse increasing in voltage at intervals of 1 second. After exposure to the acetic acid a portion of the animals were sacrificed and organs removed and weighed. Blood from the caudal vein was taken for analysis and blood cells counted using standard methods. Physical work capacity was determined in mice only on the basis of duration of running on a treadmill. Histological cross sections were stained and a number of erythrocyte metabolism parameters measured. Concentrations of volatile metabolites in exhaled air was determined for rats.

After short exposure to acetic acid in concentration of 10 to 30 mg/m<sup>3</sup>, mice's motor activity increased compared to controls, possibly due to stress induced by the odor. Longer-term experiments showed that exposure to the acid was associated with diminished motor activity at concentrations from 36 to 80 mg/m<sup>3</sup>. Significant effects were found for a number of behavioral parameters. At a concentration of 27 mg/m<sup>3</sup>, no behavioral effects were found. Gas concentration of 56 to 75 mg/m<sup>3</sup> led to significant decrement in the capacity for impulse summation. Long-term exposure to a concentration of 36 mg/m<sup>3</sup> and above decreased work capacity in mice by a factor of approximately 2. One day's exposure to a concentration of 500 mg/m<sup>3</sup> had no effect on treadmill running. Rats' weight decreased compared to control animals starting at a concentration of 75 mg/ml<sup>3</sup> for 17 days of exposure. Weight loss in mice occurred at concentrations above 56 mg/m<sup>3</sup>. Weights of organs appeared to be affected by the treatment, but in different directions for different animals and mouse species. Histological changes were found in the spleen, kidneys, and brain after long-term exposure to high levels (>75 mg/ml<sup>3</sup>) of acetic acid. No changes were noted in metabolism or blood cells. Exhalation of ethylene and acetone increased during the initial period of exposure to acetic acid in concentrations of 36 mg/m<sup>3</sup> and above but subsequently returned to normal levels. Very high (350-500 mg/m<sup>3</sup>) concentrations of acetic acids led to a significant decrease in ethylene and an eightfold increase in acetone, reflecting changes in lipid peroxidation.

P601

The minimum effective concentration of acetic acid for mice and rats under conditions of constant inhalation is set at 36 mg/m<sup>3</sup>. Not all effects increased in magnitude as concentration increased, suggesting the possibility of accelerated adaptation for higher concentrations.

PAPER:

P614(14/87) Palets BL, Popov AA, Tikhonov MA, Panchenko VS.

**Regulation of hemodynamics in simulation of transition to weightlessness.**

Fiziologiya Cheloveka.

13(4): 627-632; 1987.

[7 references; 3 in English]

Authors affiliation: Institute of Cybernetics, Ukrainian Academy of Sciences

Mathematical Modeling, Cardiovascular and Respiratory System, Hemodynamics  
Humans

Weightlessness, Initial Response; Countermeasures, LBNP, Hypovolemia

**Abstract:** The goal of this work was to develop a mathematical model of the rapid responses of the cardiovascular system to weightlessness and the effects of several techniques to limit the adverse effects of weightlessness by decreasing blood volume shift to the central portion of the body (hypovolemia, LBNP, and occlusion of the thigh). In this model the cardiovascular system is represented as a network of segments with parameters reflecting the pumping functions of the right and left cardiac ventricles and the resistance-capacitance properties of systemic and pulmonary circulation. Each segment is associated with parameters representing: distance between the segment center and the foot ( $l_1$ ) and dorsal surface ( $m_1$ ), and also the angle of inclination with respect to the horizontal ( $\varphi_1$ ). The position of the body is represented by three angles of inclination for the calves  $\varphi_1$ , thighs  $\varphi_2$ , and head, arms and trunk  $\varphi_3$ . Equations are given for the position of vessels in the calves, thighs, and other parts of the body as follows:

Vessels in the calves:  $h_k = l_k \sin \varphi_1 + m_k \cos \varphi_1;$

Vessels in the thigh:  $h_m = 2h_k + (l_m - 2l_k) \sin \varphi_2 + m_m \cos \varphi_2;$

Vessels elsewhere:

$$h_n = h_m + (l_n - 2l_k) \sin \varphi_2 + m_n \cos \varphi_2 + (l_n - 2(l_m - l_k)) \sin \varphi_3 + m_n \cos \varphi_3.$$

Upon transition to weightlessness, the rate of filling of the cardiac cavities and pressure within them increases significantly. Therefore the model includes a nonlinear description of the diastolic function relating volume ( $v$ ) and pressure ( $p$ ) of the cardiac ventricle. In addition, the representation of the cardiac pumping function makes provision for a plateau in the function relating stroke volume ( $s$ ) to end-diastolic filling ( $w$ ) for large values of  $w$ . The equations are as follows:

$$p = \begin{cases} a(v-u) + b(v-u)^2, & v > u \\ d(v-u), & 0 \leq v < u; \end{cases}$$

$$q_0 = \begin{cases} (p_0 - p + \Delta h N) / R_0, & 0 < \tau \leq \tau_d \\ 0, & \tau_d < \tau \leq T; \end{cases}$$

$$v(t) = v_0 + \int_0^t (q_0 - q) dt.$$

$$q = \begin{cases} (k\omega - u_0) / (T - \tau_d), & \omega < \omega_{max}, \tau_d < \tau < T \\ (k\omega_{max} - u_0) / (T - \tau_d), & \omega \geq \omega_{max}, \tau_d < \tau < T \\ 0, & 0 < \tau < \tau_d; \end{cases}$$

$$\omega = v|_{\tau=\tau_d},$$

$$\tau_d = \alpha T + (1-k)\beta,$$

$$T = 60/F.$$



## MATHEMATICAL MODELING

where  $p$  is transmural pressure in the ventricle;  $v$  is the volume of blood in diastole;  $q$  is the mean minute volume of blood flow on exiting the ventricle;  $p_v$  is the filling venous pressure;  $h$  is the difference between venous receptors and cardiac ventricles;  $N$  is an index of gravity;  $u$  is the unstressed volume of the ventricle;  $w_{\max}$  is the upper boundary of the change interval  $w$  in which heterometric self-regulation occurs;  $a$ ,  $b$ ,  $d$  are parameters of diastolic elasticity;  $R_0$  is resistance of the atrioventricular valve;  $F$  is heart rate;  $T$  is cardiac cycle duration;  $\tau_d$  is duration of diastole;  $k$  is an indicator of the inotropic state of the heart;  $i$  is time within the cardiac cycle;  $\alpha$ ,  $\beta$ ,  $u_0$  are constants; and  $t$  is time. Regulated parameters within the circulatory system are heart rate, resistance of system arteries, unstressed volume of system veins, and inotropic state of the heart. Regulation of hemodynamics occurs through baroreflexes with 3 reflexogenic zones. Constants are set on the basis of physiological norms in horizontal and passive upright positions.

Transition to weightlessness was modeled by shutting off the gravitational component of pressure ( $N=0$ ) and increasing the total volume of blood by 2.5% to simulate passage of fluid from extravascular space into the veins. Effects of decreasing total volume of blood (hypovolemia), and use of LBNP and occlusion cuffs were also modeled. The authors conclude that this model adequately describes the initial central hemodynamic response to transition to weightlessness in humans. Central hemodynamic responses to transition to weightlessness are strongly dependent on the fact that the right cardiac ventricle functions on a plateau of the pumping function curve (because volume of the left ventricle has already reached its limits). Hypovolemia, LBNP, and occlusion cuffs in weightlessness act to decrease the pressure on the volume of the left ventricle only when overloading of the volume of the right ventricle decreases and its functioning moves from the plateau to the inclined portion of the curve. LBNP is the most effective of the techniques examined for decreasing central blood volume.

Figure 1: Initial circulatory response on transition to weightlessness

Figure 2: Responses of the circulatory model to decreased total blood volume under simulated weightlessness

Figure 3: Change in hemodynamic parameters during LBNP in weightlessness

Figure 4: Effects of occlusion cuffs in weightlessness

## METABOLISM

(See also: Adaptation: P617; Space Biology: P592, CR7, M117)

### PAPER:

P606(14/87)\* D'yakonov MM, Persianova VR.

**Regulation of metabolism during parachute jumps.**

Kosmicheskaya Biologiya i Aviakosmicheskaya Meditsina.

21(4): 72-73; 1987.

[9 references; none in English]

Metabolism, Metabolic Parameters

Human, Parachute Jumpers

Psychology, Stress; Nutrition

Abstract: Metabolic parameters were measured in 6 parachute jumpers (aged 19-21, with at least a year of parachute experience) in a baseline period, immediately after landing, and 12 hours after landing. During the latter period, no food was consumed, and subjects had a night's sleep. Metabolic parameters included gas exchange during the jump, and glucose, ATP, and cholesterol in capillary blood. Energy expenditure at the moment of the jump was 242-256 cal/hr with a high respiratory coefficient. Although blood glucose concentrations were unchanged at the moment of landing, they had diminished significantly after 12 subsequent hours without eating. ATP concentration dropped significantly at the moment of landing. Cholesterol remained at baseline at the moment of landing but had increased after 12 hours. The authors recommend that during the days preceding a parachute jump and on the day of the jump itself, the diet should contain a high proportion of easily assimilable carbohydrates and that food should not be ingested for a relatively long time subsequent to a jump.

P613(14/87) Polozhentsev SD, Rudnev DA, Kuvshinik AV.

**Changes in lipid metabolism and hormonal status during adaptation to long-term emotional stress and physical exertion.**

Fiziologiya Cheloveka.

13(4): 616-620; 1987.

[13 references; none in English]

Authors' affiliation: S.M. Kirov Academy of Military Medicine

Metabolism, Lipid; Enzymology, Catecholamines

Humans

Adaptation; Psychology, Stress; Human Performance, Physical Exercise

**Abstract:** Subjects in this experiment were 236 apparently healthy individuals, aged 18 and 19 (presumably military recruits), who were undergoing emotional (separation from home, adjustment to very different living conditions, etc.) and physical (strenuous work, daily conditioning exercises, including a 3 km run). Two periods were arbitrarily selected for study: the first period of adaptation was defined as days 1-20 and the second period as days 35-50. Within each period, measurements were made every 5 days. The following parameters were measured in serum of venous blood to reflect lipid metabolism: total cholesterol (TC), triglycerides (TG), very low density lipids (VLDP), low density lipids (LDL), and lipid hydroperoxide (LHP). In addition renal excretion of epinephrine and norepinephrine were recorded during the first 20 days of adaptation and somatostatin and insulin were measured in blood during a like period. A control group of (30 people) of matched ages was not exposed to the stress factors.

In general, the lipid metabolism parameters measured were no different than control levels during the first 5 days of the study, after which they increased, with the exception of high density lipids which decreased. All these parameters differed significantly from control levels on days 41-45, but appeared to have normalized by days 46-50. Excretion of epinephrine and norepinephrine increased throughout the first 20 days of adaptation, reaching approximately twice control level by days 16-20. Somatostatin was no different from control level on days 1-5, but had decreased significantly on days 16-20. Insulin level increased above control level on days 1-5, but had decreased to significantly below control by days 11-15.

The authors conclude that prolonged exposure to psychological and physical stress initially gives rise to the well-known stress response associated with excretion of catecholamines. Energy is supplied for the "crisis" adaptation response from the body's carbohydrate reserves. Continuing stress leads to marked changes in hormonal status. The second phase of "emergency" regulation is accompanied by restructuring of the energy supply to provide more economic energy consumption at rest and increased output capacity when required. Energy demands are met through "fat" metabolism. Increased permeability of the arterial walls occurring as a result of hormonal changes, is accompanied during this period by increased levels of total, low, and very low density cholesterol, and triglycerides, decreases in high density lipids, and activation of free-radical lipid peroxidation. This creates conditions favoring deposits of plasma lipid on arterial walls and the development of arteriosclerosis.

P613

Table 1: Changes in concentration of various lipoprotein fractions in blood of young people adapting to prolonged emotional and physical stress

Table 2: Changes in renal excretion of epinephrine and norepinephrine in young people adapting to prolonged emotional and physical stress

Table 3: Changes in insulin and somatostatin in blood of young people adapting to prolonged emotional and physical stress

## MUSCULOSKELETAL SYSTEM

(See also: Space Biology: P592, Cr7, M117)

### PAPERS:

P596(14/87)\* Shibkova DZ, Fomin NA.

#### **Concentration of nucleic acids in the skeletal muscles of rats during hypokinesia and a recovery period.**

Kosmicheskaya Biologiya i Aviakosmicheskaya Meditsina.

21(4): 28-31; 1987.

[17 references; 1 in English]

Musculoskeletal System, Nucleic Acids

Rats

Immobilization; Psychology, Stress

**Abstract:** A total of 140 male Wistar rats were used in the experiment. Experimental rats were maintained in immobilization cages; control rats lived in normal vivarium conditions. Both groups received the same standard diet. Every 5 days animals in both groups were weighed. After 60 days of hypokinesia, experimental animals were placed in cages allowing normal freedom of movement. On days 3, 10, 20, 30, and 60 of hypokinesia, and 3, 10, 20, and 30 of recovery, a portion of the animals were sacrificed and the gastrocnemius muscle removed, cleaned of cartilage, weighed, and homogenized. A sample weighing 500 mg was removed from the homogenate and separated into nucleic acids. Quantity of DNA and RNA were determined spectrophotometrically.

Muscle weight decreased during month 1 of hypokinesia for the experimental group and then began to stabilize (graph shows slight increase), remaining below baseline and increasingly below control level until hypokinesia terminated. After treatment terminated, muscle weight increased at a rate 4 times that of control during the same period, remaining, however, below control level. In the control group, physiological growth was accompanied by increases in DNA and RNA. Two months of hypokinesia significantly depressed increase in nucleic acids, DNA had increased by only 18.4% on day 60, while RNA was below control level. At the end of 30 days of readaptation, DNA and RNA no longer differed from control levels. The fact that during hypokinesia, RNA decreased relative to DNA suggests inhibition of the transcription process. The rapid increase in RNA during adaptation led to a sharp increase in the RNA/DNA ratio, implying acceleration of transcription of DNA. It is important to note that throughout hypokinesia, concentration of DNA per gram tissue was more than 50% higher than for the control, while RNA concentration did not differ from that of the control. These data can be explained with reference to microscopic examination results indicating that during hypokinesia the number of nuclei in muscle fibers increases, leading to amitotic division. Multinucleated cells can be considered a functional reserve resulting from amitosis, and is a means of adaptation of tissue to adverse factors. The authors conclude that this leads to termination of growth of skeletal muscles and inhibition of the process of age-related nucleic acid accumulation in the gastrocnemius muscle. The concentration of the genetic DNA and RNA matrices is highly dependent on muscle activity. Restoration of normal motor activity activates genetic mechanisms for regulating biosynthesis, acceleration of

## MUSCULOSKELETAL SYSTEM

P596

reparation, and normalization of muscle tissue.

Table: Amount and concentration of nucleic acids in the gastrocnemius muscle of rats during 60 days of hypokinesia and a readaptation period

Figure 1: Changes in weight of gastrocnemius muscle

Figure 2: Changes in RNA/DNA ratio

## NEUROPHYSIOLOGY

(See also: Developmental Biology: P583; Space Biology: CR7, M117)

### PAPERS:

P621(14/87) Viru AA, Tendzegol'skis ZhL, Karel'son KM, Alev KP, Smirnova TA. **Relationship between changes in concentration of beta-endorphins and hormones in the blood during exercise.**

Voprosy Meditsinskoy Khimii.

33(3): 28-32; 1987.

[20 references; 15 in English]

Neurophysiology, Beta-endorphins; Endocrinology, Pituitary, Adrenal Cortex  
Humans, Athletes, Patients  
Physical Exercise

**Abstract:** Three groups of subjects participated in this experiment: group 1 contained 6 students, aged 18-23 years, who did not participate in physical training; group 2 contained 6 highly trained rowers (aged 17-22), and group 3, 10 men (aged 21-39) who had been engaging in physical training as a medical measure (medical conditions not specified). Before the beginning of the experiment maximum oxygen consumption was measured for each individual using graded physical exercise with a 1 minute finishing spurt. Maximum oxygen consumption per 1 kg body weight (in  $\text{ml}\cdot\text{min}^{-1}$ ) was 42-61, 50-62, and 40-71 in the three groups, respectively. In the morning, after breakfast, each individual exercised for 2 hours on a bicycle ergometer. Instructions were to attempt to maintain a level of work equal to 60% of that subject's maximum oxygen consumption. Oxygen consumption measured during minutes 29, 59, and 119 of exercise showed that this level was fairly well maintained. During exercise maximum oxygen consumption varied between 44-76% and heart rate between 150 and 180 bpm. In a baseline period and on minutes 30, 60, and 120 of the exercise (and 1 hour afterward for group 3) venous blood was taken from the cubital vein. Blood was centrifuged and concentration of beta-endorphins determined using radioimmune assay. In addition, hydrocortisone, corticotropin, and somatotropin were measured in all groups, while insulin and triiodothyronine were measured in group 1 only.

Individual differences in beta-endorphin levels were great during the baseline period, tending to be highest in the athletes. The only statistically significant difference noted during exercise was an increase in the athletes (group 2) at the end of the exercise period. Four reaction types were identified: 1) increased beta-endorphins during the first 30 minutes followed by a decrease to below baseline; 2) bimodal pattern, with maxima at minutes 30 and 120; 3) increased concentration only at the end of the exercise period; 4) decreased concentration throughout the period (or slight increase at the end). Athletes tended to show pattern 2; while pattern 1 was only seen in the relatively untrained groups. It was further discovered that individuals with a relatively high maximum oxygen consumption tended to show patterns 2 and 3 (sic., not confirmed by table), in which beta-endorphins increased at the end of the exercise period. The absence of an initial increase in beta-endorphins during exercise (patterns 3 and 4) was only observed when proportion of maximum oxygen capacity was less than 55%. Non-athletes who showed the bimodal pattern of beta-

P621

corticotropin during the first hour of exercise, and a subsequent decrease to below baseline. In all the remaining untrained subjects, no patterns of change in corticotropin could be discerned, while the concentration of hydrocortisone decreased throughout the exercise period. Where beta-endorphin showed patterns 1 and 2, level of hydrocortisone and corticotropin were elevated at minute 30. These data support the hypothesis that concentration of beta-endorphins in the blood and activity of the pituitary-adrenal cortex system are correlated in the stress reaction. This is demonstrated by the parallel increase in beta-endorphins and corticotropin in the initial stage of exercise, as well as the signs of decreased pituitary adrenal activity and parallel decrease in endorphins after prolonged exercise. The authors suggest that decreased synthesis of proopiomelanocortin or exhaustion of reserve sources is the source of this parallelism. The fact that some people do not demonstrate signs of activation of the pituitary-adrenal cortex system or of enhanced production of beta-endorphins even after 2 hours of exercise indicates that in some individuals these processes are relatively insensitive to physical exercise. In untrained subjects concentrations of somatotropin and decreased concentration of insulin were more pronounced when there was an initial increase in beta-endorphin. This association did not hold true in subjects undergoing an exercise program for medical reasons.

Table 1: Change in concentration of beta-endorphins in blood plasma during 2 hours of exercise on a bicycle ergometer

Table 2: Distribution of different patterns of changes in beta-endorphins in blood plasma in subjects in various groups and as a function of level of maximum oxygen consumption

Table 3: Change in concentration of beta-endorphins in certain hormones in the blood in untrained students during a 2-hour period of exercise

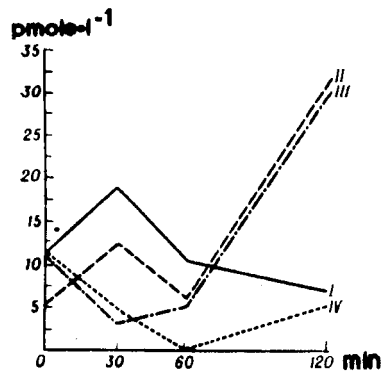

Figure: Four patterns of changes in the concentration of beta-endorphins in blood plasma (I, II, III, IV)



**NUTRITION:** See Metabolism: P606; Space Biology: M116  
**OPERATIONAL MEDICINE:** See Space Biology: CR7, M116, M117

## PERCEPTION

(See also: Space Biology: M117; CR7)

### PAPERS:

P609(14/87)\* Golobeva TI, Kuz'min MP.

**The effect of intermittent exposure to hypercapnia on visual functioning.**

Kosmicheskaya Biologiya i Aviakosmicheskaya Meditsina.

21(4): 78-80; 1987.

[4 references; none in English]

Perception, Visual Functioning; Adaptation

Humans

Hypercapnia

Abstract: Visual function was studied in 4 subjects during a 40-day period of exposure to an atmosphere with CO<sub>2</sub> concentration of 1.3%. During this period CO<sub>2</sub> rose to 4% on days 22 and 39 for 48 hours. Pressure increased over a 24-hour period in the first instance and a 48-hour period in the second. Dark adaptation was measured using a standard paradigm on days 3, 6, 8, 10, 12, 15, 17, 22, 25, 27, 30, 32, 35, and 39. An ophthalmological examination and measurement of intraocular pressure were performed before and after the treatment. Dark adaptation time fluctuated: between 28 and 97 seconds during moderate hypercapnia. A trend toward improvement in this parameter was noted as subjects adapted to hypercapnia. When CO<sub>2</sub> level was increased to 4% on day 22, dark adaptation time increased, but decreased to baseline level after hypercapnia was again reduced. When CO<sub>2</sub> pressure increased again on day 39, 2 subjects showed a significant slowing of dark adaptation and 2 showed no effect. The smaller effect of increased hypercapnia is attributed to the lower rate at which hypercapnia increased on day 39. Ophthalmological examination after hypercapnia showed distension of retinal arterioles and veins and increase in intraocular pressure. Visual acuity was unchanged. The authors conclude that the vascular system of the eye shows significant adaptive capacity.

**PERSONNEL SELECTION:** See Cosmonaut Training: M115; Space Biology: M116, CR7, M117

**PSYCHOLOGY:** See Cardiovascular and Respiratory Systems: P595; Cosmonaut Training: M115; Endocrinology: P618; Enzymology: P616; Metabolism: P606; P613; Musculoskeletal System: P596; Space Biology: CR7, M116, M117

### **RADIOBIOLOGY**

(See also: Botany: P607; Space Biology: CR7, M116, M117)

#### **PAPER:**

P611(14/87)\* Grigor'yev YuG, Stepanov VS, Batanov GB, Beskhlebnova LI, Mityayeva ZYa, Paramonov AA, Salimov RM.

**The combined effects of microwave and ionizing radiation.**

Kosmicheskaya Biologiya i Aviakosmicheskaya Meditsina.

21(4): 4-9; 1987.

[8 references; 3 in English]

Radiobiology, Bioeffects; Psychology, Behavior, Imprinting; Immunology  
Review Paper, Rats, Chicks  
Microwaves, Ionizing Radiation, Combined Effects

**Abstract:** This paper reviews a number of investigations of the effects of the combination of microwave and ionizing radiation on biological subjects. Such studies are of particular importance in development of safety standards for exposure to radiation on manned space flight. In one such experiment 18 female rats were exposed to an electromagnetic field of 9340 MHz (wavelength = 3.2 cm. density of 200 uW/cm<sup>2</sup>) for 30 minutes a day for 8 days. On day 9 experimental rats and 36 controls were subjected to gamma radiation of 5.5 Gy (dose rate of 0.01 Gy/sec) in a single session. Preliminary exposure to microwaves reduced mortality by a factor of 1.5 and increased survival time. Experiments with higher doses of microwaves, however, have found an additive effect with ionizing radiation. This same study considered the effects of microwaves and ionizing radiation on immunological parameters of lymphocyte blast transformation and plaque development. Blast transformation was increased by microwaves, decreased by ionizing radiation, and increased by the two factors combined to an extent greater than for microwaves alone. Addition of microwaves to ionizing radiation attenuated the effect of the latter on plaque development by a factor of 2, which was still higher than baseline.

Behavioral responses have been used in other studies in attempts to investigate very weak, nonspecific reactions to microwave and ionizing radiation. In one study, white rats were subjected to gamma-radiation in a dose of 0.34 Gy for 20 minutes. Control animals were not irradiated. Half of each group was subjected to microwave radiation (density 40 uW/cm<sup>2</sup>, duration 1 and 5 minutes) on the following day. Gamma radiation alone affected 1 of 4 motor activity parameters. Microwaves alone or microwaves combined with gamma irradiation led to no changes in motor activity. Because of previous scientific evidence that microwaves and ionizing radiation affect the nervous system, it was decided to use chick imprinting as a dependent variable. One group of chicks was irradiated in the egg 24 hours after the beginning of incubation with continuous microwaves (frequency=9240 MHz, density 40 uW/cm<sup>2</sup>); a second group was subjected to

P611

gamma radiation in a dose of 0.36 Gy; a third group to both factors, with microwaves first; and a fourth group to no irradiation. Imprinting training was given during the critical period and memory for the imprint object tested 24 hours subsequently. Animals subjected to gamma radiation, alone or combined with microwaves, showed no preference for the imprinted object 24 hours after imprinting; animals exposed to microwaves alone were no different than controls in preferring the imprinted object.

Table 1: Change in immunobiological parameters in response to the combined effects of microwaves and gamma-irradiation

Table 2: Characteristics of imprinting in chicks after exposure to microwave and ionizing radiation

P612(14/87) Fedorenko BS, Savchenko NYa, Vorozhtsova SV, Gerasimenko VN, Kabachenko AN, Portman AI.

**Biological effectiveness of helium ions and protons of relativistic energy.**

Radiobiologiya, XXVII(3): 339-343; 1987.

[5 references; none in English]

Authors' affiliation: Institute of Biomedical Problems

Radiobiology, Biological Effectiveness; Hematology, Lymphocytes; Cytology; Genetics, Chromosome Damage; Reproductive Biology, Spermatozoa  
Human Blood, Mice, Rats  
Helium Ions, Relativistic Energy

**Abstract:** Helium protons and neutrons were accelerated on a synchrotron. Gamma-quanta of  $Co^{60}$  or X-rays of 180 kW were used for comparative purposes. Doses ranged from 0.12 to 9.0 Gy, the dose rates of helium protons and ions were 2.0 and 1.5 cGy/sec., while those of gamma and X-rays were 2.0 and 5.0 cGy/sec., respectively. Lymphocytes of human peripheral blood in culture were examined. In addition, hybrid mice of both sexes and adult rats (5 to 60 per group) were used as subjects. The following parameters were studied: animal mortality, viability of cells from the spermatogenic epithelium of mice, proliferation activity, number of cells, frequency and nature of cell aberrations, and nature of chromosome breaks in human peripheral blood, frequency and latency of cataracts in mice, frequency and latency for development of and histological structure of neoplasms in rats, nature and degree of destructive changes in neurons of the cerebral cortex in rats. Results were tested statistically using t-tests and chi square. Relative biological effectiveness values were computed.

Comparative study of mortality of mice and rats in a 30-day postradiation period showed that accelerated, charged particles are more effective than gamma-quanta. The  $LD_{50}$  for helium ions for mice was 5.2 Gy, while that of gamma-quanta was 6.2; the corresponding figures for rats were 5.3 Gy, and 6.9 Gy.

The results of studies of cytogenetic damage in cultures of human peripheral lymphocytes showed that destruction of the nucleus is greater after exposure to accelerated charged particles. For all cytogenetic criteria it was found that the number of aberrant cells was greater for a given dose of helium ions than for the same dose of gamma radiation. Helium protons also caused more damage than the same dose of gamma radiation. Similar results were found with chromosomes: at doses of 1-4 Gy, damage induced by helium ions and protons was 2-2.5 times more frequent than that induced by gamma radiation. Analogous results were found when genetic damage was studied in the corneal epithelium and epidermis of mice. Recovery after irradiation was more rapid after exposure to gamma irradiation. Dose-effect curves for helium ions and protons showed virtually linear increases up to doses of 2 - 2.5 Gy, followed by a plateau at about 80% effectiveness. Number of mouse spermatogones surviving radiation decreased with dose for all types of radiation studied. Type B spermatogones were more sensitive to all types of radiation than Type A. When structural damage to the neurons of the cerebral cortex of rats was studied 1, 3, and 6 months after exposure to radiation, it was found that the extent of neuron damage after irradiation by helium protons and ions was 2-3 times that of gamma radiation at the same dose. Helium irradiation decreased the latency for mice to develop cataracts by 8-10 weeks compared to similar doses of gamma-

P612

irradiation. All forms of radiation were carcinogenic but significant differences were not found among different types of radiation. Depending on subjects and effect studied, RBE varied from 1.0 (frequency of aberrant epidermis cells 24 hours after irradiative, reproductive death of epidermis cell, viability of intermediate type spermatogenic epithelium) to 11.6 (for dystrophy of cerebral cortex neurons 6 months after irradiation) for protons and from 1.0 (same parameters) to 7.2 (same parameter) for ions. The authors note that the doses of radiation studied are significantly greater than those encountered in space.

Table 1: Parameters approximating dose-effect equations

Table 2: Frequency of formation of aberrant mitoses in cultures of human blood lymphocytes after irradiation by helium protons and ions and gamma-quanta

P612

Table 3: Experimental values of RBE coefficients for helium ions with energy of 4 HeV/nuclon and protons with energy of 9 GeV

Subject	Effect	RBE	
		protons	ions
Mice	CD <sub>50/30</sub>	--	1.2
Rats		1.3	--
Mice			
corneal epithelium	Frequency of aberrant mitoses		
	after 24 hrs 30% damage	1.9	2.7
	50% damage	1.8	2.6
	after 72 hrs 30% damage	2.1	2.2
	50% damage	1.5	1.6
	Decreased mitotic index		
	after 24 hours	1.8	2.5
	after 72 hours	1.3	1.5
skin epidermis	Decreased mitotic index		
	after 24 hours	1.6	1.6
	Frequency of aberrant mitoses		
	after 24 hours	1.0	1.0
	Reproductive death of epidermis cells	1.0	1.0
spermatogenic epithelium	Viability of spermatogenic epithelium (D <sub>37</sub> ):		
	Type A	1.1	1.0
	Intermediate type	1.0	1.0
	Type B	2.0	1.3
lens	Frequency of cataract after:		
	20 weeks	1.3	1.2
	30 weeks	1.9	2.2
	40 weeks	2.4	2.6
Rats			
neurons of cerebral cortex	Dystrophy after:		
	1 month	4.6	4.1
	3 months	8.2	6.5
	6 months	11.6	7.2
neoplasms	Frequency in mammary gland	1.7	1.3
Human lymphocytes in culture	Frequency of aberrant cells	1.4	1.6
	Frequency of chromosome aberration	1.6	1.7
	Number of paired fragments	1.3	1.4
	Number of dicentrics in a ring	1.4	1.8

Table 4: Number of remote dystrophic changes in neurons of the outer granular layer of the cerebral cortex of rats after irradiation

P612

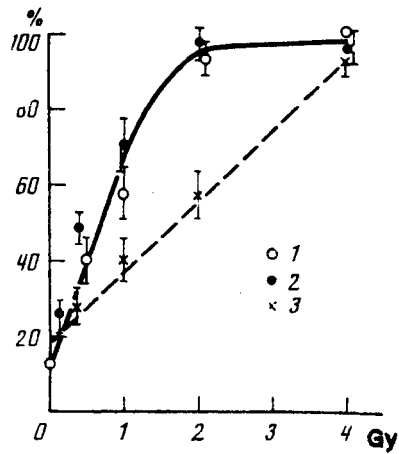

Figure: Frequency of cataracts in mice as a function of dosage 40 weeks after irradiation by helium ions (1), protons (2) and gamma quanta  $^{60}\text{Co}$  (3)  
Ordinate - frequency of cataracts; Abscissa - radiation dose

P615(14/87) Shubik VM, Levin MYa, Mashneva NI, Pul'kov.

**Combined effects of ionizing radiation and physical exercise on certain parameters of nonspecific protection and immunity.**

Radiobiologiya.

XXVII(4): 548-550; 1987.

[1 reference; none in English]

Authors affiliation: Leningrad Scientific Research Institute of Rational Hygiene, USSR Ministry of Health

Immunology, Non-specific Protection, Humoral, Cellular

Rats, Mice

Radiobiology, Ionizing Radiation; Physical Exercise

**Abstract:** This work investigated the effects of various types and intensities of exercise followed by external (X-rays) and internal ( $^{90}\text{Sr}$ ) irradiation on humoral and cellular parameters of non-specific immunity in laboratory animals. Subjects were a total of 110 male white rats and 300 mice. The rats were exposed to whole body X-ray irradiation in a dose of 3 Gy, with dose rate of 0.5 Gy/min. The mice received  $^{90}\text{Sr}$  daily with their drinking water in a dose of  $11.1 \cdot 10^5$  Bq/kg per day. The rats were divided into 4 groups. Group 1 animals swam in a pool for up to 90 minutes for total exercise period of 58.8 hours over a 3-month period (intense dynamic exercise). Group 2 spent a total of 6.2 hours swimming (moderate dynamic exercise). Group 3 were forced to cling to a vertical pole 3 times a week for 2-10 minutes (static exercise). Group 4, the control, did not exercise but was exposed to radiation. Immunological parameters were measured 1, 10, and 30 days after irradiation. Parameters measured were migrational properties of leukocytes in agar and capacity of lymphocytes to react with PHA in an inhibition of leukocyte migration reaction.

Groups of mice were also compelled to perform exercise differing in type and intensity. Groups 1, 2, and 3 swam for 30 minutes twice a week (intense with stress), ran in a revolving drum at 44 revolutions per minute (intense) or ran in a wheel (moderate); group 4 did not exercise. Three to 4 months after exercise began the animals were fed  $^{90}\text{Sr}$  for a period of 3 months. Total dose in skeleton was 10 Gy. At the end of this period the mice were sacrificed and the bactericidal response of blood serum to white staphylococci was measured. Lysozyme, beta-lysine and complement activity and concentration of autoantibodies in response to liver tissue were also studied.

In the rat experiment, it was found that moderate exercise (groups 2 and 3) increased the migrational properties of leukocytes before and after irradiation, strenuous exercise did not have this effect. After moderate exercise, decreased migration occurred only during the height of radiation sickness (i.e., 10 days after irradiation), while in the control and strenuous exercise group this effect was present on day 1 post irradiation. After 30 days, the animals in the moderate exercise groups showed higher values of this parameter than animals in the control and strenuous exercise groups. Combined effects of radiation and strenuous exercise sharply decreased inhibition of migration in the presence of PHA on days 1 and 10 post irradiation. After 30 days this parameter had returned to control value in group 1, and was elevated in the other 3 groups.



P615

The control group of mice displayed decreased bactericidal properties and lysozyme and complement activity and threefold increase in titer of autoantibodies after irradiation. Preliminary moderate exercise attenuated the increase in autoantibodies and normalized the other parameters. More strenuous exercise combined with stress depressed the bactericidal capacity of blood serum, indicative of nonspecific immunological protection. The authors conclude that moderate preliminary exercise decreases radiation damage to the immunological system occurring after external or internal irradiation. Very strenuous exercise, particularly if combined with stress, may have the opposite effect.

Table: Parameters of nonspecific immunity in irradiated and nonirradiated rats after various levels of exercise

P563(14/87)\* Popov AV, Bochenkov AA, Ivnitskiy YuYu, Volkovskiy YuV.  
**The effects of pyrocetam on mice's tolerance of hypoxic hypoxia 2-3 months after irradiation with X-rays.**

Kosmicheskaya Biologiya i Aviakosmicheskaya Meditsina.  
 21(4): 64-66; 1987.

[14 references; 4 in English]

Radiobiology, Hypoxia, Tolerance; Neurophysiology, Brain Bioenergetics  
 Mice, Male  
 Pharmacological Countermeasures, Pyrocetam

**Abstract:** This experiment investigated altitude toleration in mice during the recovery period after acute radiation sickness and the possibility of correcting intolerance with pyrocetam (2-Oxo-1-pyrrolidinylacetamide), which has a beneficial effect on the bioenergetic processes in the brain. Male mice were exposed to X-radiation of 4.75 Gy at a dose rate of 0.67 Gy/min. Two months later these mice were divided into 2 groups: one was injected intraperitoneally with 200 mg/kg of pyrocetam every day for the next 30 days; the second was injected with a saline solution. On day 90 after radiation 2 experiments were performed. In the first tolerance for high altitude hypoxia was tested by raising animals in a barochamber to a height of 11,000 m at rate of 15 m/sec. Time at which convulsions and apnea commenced was recorded. The second experiment exposed animals to a height equivalent of 7000 m for thirty minutes, after which they were sacrificed. Activity of succinate dehydrogenase in a brain homogenate, and of lactate dehydrogenase in a brain supernatant were measured. Control groups of animals never irradiated (with or without pyrocetam) were used for comparative purposes.

Administration of pyrocetam to non-irradiated animals increased their likelihood of surviving ascent to 11000 m, and lengthened the interval before convulsions and apnea occurred at that altitude. Previous irradiation decreased these parameters. Administration of pyrocetam to irradiated animals improved their survival probability to the level of non-irradiated animals given this drug. Pyrocetam also lengthened the time before irradiated animals suffered from convulsions and apnea, but these times remained significantly shorter than those of control animals. A 30-minute period of hypoxia equivalent to 7000 m increased succinate dehydrogenase activity in all groups but failed to significantly affect lactate dehydrogenase activity. Administration of pyrocetam heightened the increase in succinate dehydrogenase activity in response to moderate hypoxia in both untreated and irradiated animals. Succinate dehydrogenase activity increased more in untreated than in irradiated animals. The authors conclude that their data shows that tolerance of altitude hypoxia in mice is diminished during the period of residual effects of acute radiation sickness and is partially normalized by pyrocetam. They associate this effect with pathological changes in nerve tissue. Disruption of the compensatory activation of succinate dehydrogenase in the brain in response to hypoxia is associated with these changes.

Table 1: Tolerance of hypobaric hypoxia in mice

Table 2: Effect of hypobaric hypoxia on the activity of succinate and lactate dehydrogenase in the brain tissue of mice

## SPACE BIOLOGY AND MEDICINE

### PAPERS:

P592(14/87)\* Gizenko OG, Il'in YeA, Savina YeA, Serova LV, Kaplanskiy AS, Smirnov KV, Konstantinova IV.

**Experiments on rats flown on the "Cosmos-1667" biosatellite: Major goals, experimental conditions and results**

Kosmicheskaya Biologiya i Aviakosmicheskaya Meditsina.

21(4): 9-16; 1987.

[15 references; 1 in English]

Space Biology, Body Fluids, Endocrinology, Enzymology, Gastrointestinal System, Hematology, Immunology, Metabolism, Musculoskeletal System, Metabolism, Reproductive Biology

Rats

Space Flight, Short-term, Cosmos-1667; Adaptation, Weightlessness

**Abstract:** Ten healthy adult Wistar rats were flown on the "Cosmos-1667" biosatellite from 10-17 July 1985. The rats were housed in a "Biosvivariya" common cage, fed a pastelike food (55g/day for one animal), and allowed ad libitum access to water. The major goals of the flight experiments were: to establish the initial signs of structural and metabolic shifts in major physiological systems; to evaluate the processes occurring in mammals during the initial period of adaptation to weightlessness; and to juxtapose the results of short- and long-term flights in order to gain understanding of the dynamics of adaptation to weightlessness. The experiments called for postflight study of the animals using previously applied and new techniques. The most important of the new techniques were electron microscopic analysis of various portions of the brain, thyroid, and parathyroid glands, and study of hormone receptors in various parenchymatous organs. A synchronous control was conducted one month after the flight. Rats in this group were housed in a mock-up of the biosatellite with maintenance, launch, and reentry conditions simulated. The flight and synchronous groups were each compared to a matched group of animals maintained in ordinary laboratory conditions. Of the 10 rats in the flight group, 7 were decapitated 4-8 hours after reentry and 3 were used for study of the reproductive function during the postflight period. Control animals were sacrificed at comparable intervals.

Flight animals appeared to be generally healthy on reentry, although they were passive and did not resist handling. Neither weight loss nor any macroscopically evident changes in organs or tissues were noted. However, the weight of the majority of the muscles studied, and of the thymus and spleen decreased, while kidney weight increased compared to synchronous control animals. Flight animals displayed distension of the stomach and overfilling with food, not noted in synchronous controls dissected at a comparable interval after feeding. This suggests that short-term exposure to weightlessness affected the smooth musculature, slowing fecal evacuation. Clear structural, metabolic, and functional changes were noted in the musculoskeletal system, analysis of which showed that the rate of atrophy varied in different muscles and bones. The greatest dystrophic changes were observed in muscle, particularly in fibers with a high level of

P592

oxidative metabolism. No major changes were seen in energy metabolism in the muscles; however, all muscles studied showed accumulation of glycogen and increased phosphorylase A and B activity. The majority of muscles studied showed a slowing in contraction and the soleus muscles displayed decreased contractile strength as well.

Histomorphometric analyses of bones (tibia, iliac, and lumbar vertebrae) showed signs of osteoporosis which were most marked in the spongy bone of the tibia proximal metaphysis. Number and functional activity of osteoblasts were depressed in all bones observed. The issue of the effects of weightlessness on bone resorption remains unresolved since increased number and activity of osteoclasts were observed only in the spongy bone of the tibia. Analysis of mechanical properties of bone showed decreased maximum relative deformation and increased modulus of elasticity. To further elucidate the origin of bone changes, the authors performed morphological analyses of the pituitary, thyroid, and parathyroid glands, which participate in humoral regulation of the growth, calcium metabolism and remodeling of bones. Space flight appeared to depress the functioning of adenohypophysis somatotrophs, which produce growth hormones, and the C-cells of the thyroid, which process calcitonin. At the same time, the functioning of the parathyroid was enhanced. These changes could lead to osteoporosis as part of adaptation to decreased gravity loading. In spite of the changes outlined, there was no alteration in total calcium and parathyroid hormone in plasma, although phosphatemia did occur.

The 7-day space flight led to clear indications of depression of erythroid hemopoiesis in marrow and especially the spleen. In marrow, concentration of erythroid elements dropped to 28.2% (control level = 36.1%). Reticulocytes in peripheral blood were also depressed. Virtually no sites of erythroid hemopoiesis could be found in the spleen. These changes did not differ from those observed after long-term flights, suggesting that the blood system adapts to weightlessness during the first 7 days in space. Immunological studies revealed no changes in T- and B-lymphocytes in the spleen, while the quantity of T-lymphocytes increased significantly in bone marrow. T-lymphocytes displayed decreased proliferation and cytotoxic activity in normal killer lymphocytes. These results imply that the capacity of the T-immunity system has decreased as early as the first week of adaptation to space.

Study of a broad spectrum of gastric enzymes revealed similar but less pronounced changes than those induced by long-term flights. With the exception of phosphatemia, no changes were noted in the electrolyte composition of blood of flight animals. Kidneys of these animals displayed increased weight, and decreased potassium, sodium, and magnesium, while calcium was unchanged. Changes in concentration of these electrolytes, especially potassium, were also noted in the myocardium, skin, muscles, and bone. Direct evidence for hypohydration was found in the skeletal muscles and heart muscles. Evidence for decreased production of ADH-vasopressin (decreased concentration of ribonucleoproteids in cytoplasm, virtual absence of synthesis of neurosecretor granules in the perikaryon, and 15% decrease in the size of neuron nuclei) was also observed in the hypothalamus-pituitary system.

The issue of how many of the changes associated with space flight are mediated by stress cannot be answered by this study. However, some indication can be found through study of the lymphoid organs and, to a lesser extent, the adrenal gland. Flight animals displayed evidence of involution of lymphoid tissue only in the thymus, without noticeable changes in the area of lymphoid follicles or the concentration of T- and B-lymphocytes in the spleen. No weight changes or signs of hypertrophy were observed in the adrenal cortex or medulla. All this suggests that even the initial stage of adaptation to weightlessness is accompanied by only a moderate stress reaction, less pronounced than that evoked by hypokinesia. Flight rats also showed some signs of decreased norepinephrine secretion, but no signs of enhanced activity of the sympathetic adrenal system were found. On the contrary, there was a significant decrease in the number of beta-receptors in the heart and spleen, suggesting decreased sympathetic regulation.

Signs of acute gravitational stress associated with return to Earth were noted in the flight animals. Morphological criteria (e.g., structure of thymus, spleen, and adrenal cortex) indicated that such stress was less pronounced than after longer flights. However, a direct relationship between stress and flight duration was not noted in biochemical analyses. Gravitational stress was associated with metabolic changes in blood such as hyperglycemia and increased antioxidant activity. Accumulation of products of lipid peroxidation was noted in the liver and muscle, but not the myocardium and blood.

No effects of space flight were found in the reproductive behavior and capacity of male rats.

The authors conclude that rate of adaptation to space flight varies for different organs and tissues and even within the same organ or tissue. Most changes noted after 7 days in space are less pronounced than those found after longer-term flights, although this is not always the case. A characteristic feature of the early stage of adaptation is lack of significant changes in biochemical parameters of the blood, while structural and metabolic changes do occur in tissue. The authors interpret this to indicate that the mechanisms supporting homeostasis at the level of the whole organism have not yet been disrupted by 7 days of weightlessness.

Table 1: Weight of body and internal organs of rats flown on "Cosmos-1667"

Group	Body wt., g	Organ weights, mg						
		Heart	Liver	Kidneys	Spleen	Thymus	Adrenals	Testes
Flight	332	960	11,014	2460*	524*	193*	42.7	2410
Vivarium	334	967	10,545	2170	592	235	42.5	2360
Synchro- nous	349	994	12,857*	2329	633	199	46.7	2730
Vivarium	348	920	9,700	2219	614	189	44.4	2854

\* Difference between experimental and control group significant,  $p < 0.05$

P592

Table 2: Weight of skeletal muscles of rats flown on "Cosmos-1667"

Group	Muscle weight, mg							
	Soleus	Gastroc-nemius	Plantaris	Long Extensor of digits	Quadriceps femurs	Triceps brachii	Biceps brachii	Brachialis
Flight	122*	1653*	281*	152	2184	111*	182*	174*
Vivarium	158	1850	343	166	2324	171	207	206
Synchronous	172	1865	325	174	2357	167	222	208
Vivarium	169	1967	356	170	2534	171	212	206

\* Difference between experimental and control group significant,  $p < 0.05$

P592

ORIGINAL PAGE IS  
OF POOR QUALITY

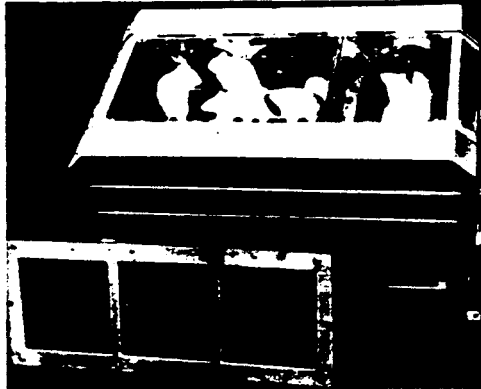

Figure: "Bios-vivaria". Overview.

## CONFERENCE REPORT:

CR7(14/87)\* Enes AE, Kovalev VYu.

**Eighth All-Union Conference on Space Biology and Aerospace Medicine.**

In: Kosmicheskaya Biologiya i Aviakosmicheskaya Meditsina.

21(4): 90-94; 1987.

**KEY WORDS:** Space Biology, Adaptation, Body Fluids, Botany, Cardiovascular and Respiratory Systems, Developmental Biology, Enzymology, Habitability and Environment Effects, Human Performance, Immunology, Life Support Systems, Metabolism, Microbiology, Musculoskeletal Systems, Neurophysiology, Operational Medicine, Perception, Personnel Selection, Psychology, Space Flight, Soyuz-T, Salyut-7, Biofeedback, Hypokinesia with Head-Down Tilt, Space Motion Sickness, LBNP, Physical Exercise, Acceleration

**Abstract:** The eighth All-union Conference on Space Biology and Aerospace Medicine was held 25-27 July in Kaluga and was organized by the USSR Academy of Sciences, the Scientific Council on Space Biology and Medicine, the Institute of Biomedical Problems of the Soviet Health Ministry, and the K.E. Tsiolkovskiy Museum of the History of Cosmonautics. Participants came not only from the USSR and socialist countries, but also from the United States, France, West Germany and West Berlin, Sweden, and India. The theme of the conference was the "Contribution of space biology and aerospace medicine to ecological science." The opening address was given by O.G. Gizenko.

The first session was titled "**Problems in ecology, habitability and hygiene.**" A number of the papers delivered were devoted to the results of toxicological and microbiological studies conducted on the "Soyuz-T" and "Salyut-7" space station and during other manned space flights. Results of study of the biological data on components of the life support systems demonstrated that the microclimate conditions met the major physiological needs of the cosmonauts. Molecular interactions of microfactors and biological substrate were identified as an area in particular need of further research. Short-term goals include a thorough evaluation of the effects of toxicants on various physiological systems. Planned study of the mechanisms by which human automicroflora mutate and vary will expand the range of pharmacological measures used and optimize their effectiveness in support of ecological equilibrium between macro- and microorganisms. Maintenance of immunological homeostasis on space flights continues to be an important area of research. Data presented at the conference concerning disruption of populations of lymphocytes with regulatory functions will serve as a basis for future studies in the area of space immunology.

The second session was devoted to "**Clinical physiological studies.**" Modern methods for selecting and conditioning pilots and cosmonauts are based on studies of the effects of ground simulations of specific flight factors on the human body. Papers delivered at this session discussed the potential for future use of LBNP, acceleration changing in sign, tests with graded physical exercise, and centrifugation for these purposes. This session also considered "Salyut-7-Soyuz" research on the effects of space flight factors on the cardiovascular, respiratory, vestibular, and musculoskeletal systems. A number of papers were devoted to space motion sickness. Recent results support theories based on hemodynamic and neuroreflex factors. Hemodynamic changes observed in weightlessness led to an alteration of the qualitative



CR7

and quantitative characteristics of afferent nerve impulses from mechanoreceptor vascular zones. According to scientists studying cardiovascular reactions in weightlessness, this is the reason for the development of specific processes disrupting the existing interactions of subsystems within the sensory system, leading to space motion sickness. On the other hand, results of study of vestibular responses by Soviet and American scientists confirm the dominance of vestibular and visual inputs. The functional changes that occur in weightlessness in the structure of neuron connections of the vestibular system are associated with alterations in afferent stimulation from the nonauditory portion of the labyrinth, and also visual and proprioceptive afferentation. The effectiveness of measures taken to prevent space motion sickness provides indirect evidence of the importance of visceral afferentation. Future trends in this area will include study of the interaction of multimodal afferentation at various levels of the central nervous system so as to identify prophylactic measures which prevent visceral symptoms.

A major portion of this session, as well as of the session focusing on **"Metabolism and its Regulation,"** was devoted to the results of simulation studies using hypokinesia with head-down tilt varying in duration. Data presented testified to the systemic nature of the changes occurring in bone tissue. In addition, mechanisms underlying disruption of processes at the subcellular level, as well as disturbances of metabolism and enzymes responsible for normal and neurological regulation of metabolic processes were discussed in detail. Much discussion was also devoted to countermeasures intended to correct fluid-electrolyte balance in space crews. As biochemical studies of crews have shown, the most promising direction is the use of drugs operating at the membrane-molecular level, combined with physical exercise.

The session entitled "Psychological aspects of performance" was devoted to psychological work capacity, measures to optimize it, questions involving flight certification examinations, and evaluation of the psychological states of crewmembers. The papers delivered provided detailed discussion of induction of a positive motivational structure in which the major motivation is goal attainment, ways to influence emotional state, the importance of personality variables, and the use of biofeedback and other self-regulation techniques. With respect to improved automation in biomedical investigation, one research trend cited involved the creation of measurement and information processing systems coordinated with a data bank on environmental factors, biophysical effects, physiological characteristics, etc.

Papers in the **"Biology"** session were devoted to the study of biological systems of plants and animals in space and ground-based simulations. One paper emphasized that all changes occurring in the circulatory system of animals in space may be considered part of a compensatory response serving to facilitate adaptation. The noted drop in the strength of animal bone tissue was attributed to decreased levels of crystal hydroxyapatite and accumulation of amorphous calcium phosphates. Changes in skeletal musculature in response to weightlessness are both systemic and differentiated and are caused by recruitment of an additional number of motor units to perform the same work (due to the decreased

CR7

contractile power of individual fibers); alteration of the central mechanisms for controlling movement and the activation sequence of motor units; and reduced circulation. In space, psychological stimuli constantly operate to alter secretion of biogenic amines, glucocorticoids and androgens in primates, and specific substrates in rodents, which may be accompanied by changes in the functional state of the central nervous system. This poses the problem of increasing tolerance of the nervous system to emotional stress. The most promising of the psychotropic drugs studied is pyrroxanum, (6-[Beta-(3'-phenylpyrrolidyl -1')propionyl]-benzodioxan-1,4 hydrochloride) which prevents the development of emotional stress and associated behavioral, visceral, and neuroendocrine effects. Administration of phenylinum (2-Phenylindandion) and piperidin ethylselenophen significantly increases the resistance of rats to audiogenic convulsions. Space flight factors did not affect fluid-electrolyte homeostasis in developing rat fetuses or radiation mutagenesis of female Drosophila. Effects of space flight factors on plants are of critical importance to the future of man's conquest of space. Temperature changes were found to have noticeable effects on physiological and genetic parameters of plants. Heavy ions in cosmic radiation decrease the reparative capacity of plant cells. All changes studied were found to be species-specific.

Many of the papers presented at the "Radiobiology" session concerned the effects of radiation on living organisms. One paper established the fact that, as is the case with other mammals, the UV-fluorescence of human leukocytes and bone marrow increases in space. Another paper presented evidence that cytogenic changes in the sex cells of mice and physical work capacity of rats depend strongly on radiation dose. The rate of recovery of spermatogenic parameters decreased as dose increased. It was argued in a third paper that adaptive responses evoked by changes in the environment increase tolerance of extreme factors. Specifically, breathing air with decreased partial pressure of oxygen decreases the effects of radiation. Data was discussed suggesting that the structural damage to plant cells from radiation is a linear function of absorbed dose. Secondary proton irradiation has a marked effect on plants, and anomalous changes are retained by the next generation.

**MONOGRAPHS:**

M116(14/87) Gazenko OG (editor).

Kosmicheskaya Biologiya i Meditsina: Rukovodstvo po Fiziologii [Space Biology and Medicine: A Physiological Manual]

Moscow: Nauka; 1987.

[320 pages; 35 illustrations; 18 tables]

Author's Affiliation: Institute of Biomedical Problems

**KEY WORDS:** Space Biology, Space Medicine, Adaptation, Botany, Cosmonaut Training, Developmental Biology, Habitability and Environment Effects, Life Support Systems, Microbiology, Nutrition, Operational Medicine, Personnel Selection, Psychology, Radiobiology, Countermeasures, Space Flight, Space Suits, EVAs, Insects

**Annotation:** This book contains detailed information about the effect of space flight factors on the human body, about life and work on board spacecraft, selection and medical conditioning of cosmonauts, support and psychological reliability of crewmembers, medical monitoring of their state and health, and means to protect cosmonauts from the adverse effects of weightlessness. The book discusses issues related to the vital functions and safety of cosmonauts wearing space suits during EVAs, their capacity for surviving on their own in various regions of the globe in the event of a forced landing, and the results of research performed on biosatellites. This book is intended for cosmonauts, engineers, and designers of space equipment, and anyone interested in the problems of cosmonautics.

**NOTE:** This book will be covered in more detail in a subsequent Digest issue.

**CONTENTS**

(Numbers in parentheses refer to page numbers in the original.)

Foreword (OG Gazenko, AG Kuznetsov) (3)

**PART 1: THE BODY AND SPACE FLIGHT FACTORS**

Chapter 1. Man in space flight (AV Yeregin, NM Rudnyy) (7)

Factors caused by flight dynamics --

Physiological and hygienic habitability factors (34)

Psychological factors (49)

Chapter 2. Weightlessness and its effects on the body --

Major mechanisms underlying the effects of weightlessness (A.I. Grigor'yev, et al.) --

Protecting the body from the adverse effects of weightlessness (A.I. Grigor'yev, et al.) (59)

Chapter 3. Psychological reliability of cosmonauts during space flight (VI Myasnikov, et al.) (88)

Cosmonauts' professional activity --

Psychological conditioning of cosmonauts (93)

Psychological support of cosmonauts in space (97)

M116

Chapter 4. Habitability of spacecraft cabins (102)

- Physiological and hygienic conditions in the cabins (SN Zaloguyev) --
- Nutrition (VP Bychkov) (108)
- Water supply (YuYe Sinyak) (115)
- Biological life support systems (GI Meleshko, YeYa Shelepev) (123)

Chapter 5. Cosmonaut performance in space suits (AS Barer, SN Filipenkov) (146)

- Physiological/hygienic and ergonomic aspects of space suit development --
- Medical support to cosmonauts wearing space suits (166)
- Biomedical results of EVAs (168)

Chapter 6. Ensuring radiation safety of the crew (YeYe Kovalev, VM Petrov) (176)

- Radiation conditions in space --
- Standards of radiation safety on space flights (185)
- Principles and methods of ensuring radiation safety (190)

Chapter 7. Crew survival after contingency landings (VG Volovich) (194)

- Survival in the arctic (200)
- Survival in the tayga (boreal forest) (207)
- Survival in the desert (210)
- Survival in the jungle (218)
- Survival under conditions of ditching in the ocean (224)

PART 2: MEDICAL SUPPORT OF COSMONAUTS

Chapter 8. Medical selection and cosmonaut conditioning (228)

- Medical selection (NN Gurovskiy, TN Krupina) --
- Conditioning cosmonauts for space flight (NN Gurovskiy) (232)

Chapter 9. Medical aid to cosmonauts (242)

- Medical monitoring of cosmonauts in space (NN Gurovskiy, et al.) --
- Means and methods of medical aid (VV Bogomolov, et al.) (255)
- Restoring the normal state of cosmonauts postflight (TN Basil'yeva, BM Fedorov) (270)

Part 3: BIOLOGICAL RESEARCH ON SPACE FLIGHTS

Chapter 10. Research on mammals (YeA Il'in) (286)

- Species of experimental animals (287)
- Selection and training of animals (290)
- Life support for animals on space flights (291)
- Major research results (294)

M116

Chapter 11. Research on microorganisms, cell cultures, fungi, plants and insects (GP Parfenov) (300)

Microorganisms (301)

Cell cultures and animal tissues (303)

Fungi (304)

Plants (305)

Insects (308)

Embryological research (308)

Biological research in space and the evolutionary significance of the force of gravity (311)

Conclusion (314)

M117(14/87) Gazenko OG (editor).

Kosmicheskaya Biologiya i Aviakosmicheskaya Meditsina: Tezisy dokladov VIII Vsesoyuznoy Konferentsii, Kaluga, 25-27 June 1986 [**Space Biology and Aerospace Medicine: Abstracts of papers delivered at the Eighth All-Union Conference, Kaluga 25-27 June 1986**]. See CR7, this Digest issue.

Moscow: Nauka; 1986.

[391 pages]

Affiliation (Conference): Scientific Council on "Space Biology and Physiology," USSR Academy of Sciences: Institute of Biomedical Problems, USSR Ministry of Health, KE Tsiolkovskiy State Museum on the History of Cosmonautics

**KEY WORDS:** Space Biology, Adaptation, Body Fluids, Botany, Cardiovascular and Respiratory Systems, Developmental Biology, Enzymology, Habitability and Environment Effects, Human Performance, Immunology, Life Support Systems, Metabolism, Microbiology, Musculoskeletal Systems, Neurophysiology, Operational Medicine, Perception, Personnel Selection, Psychology, Space Flight, Soyuz-T, Salyut-7, Biofeedback, Hypokinesia with Head-Down Tilt, Space Motion Sickness, LBNP, Physical Exercise, Acceleration

**Please note:** We will be translating many of these abstracts in future Digest issues. Readers are invited to request translations of particular abstracts.

**Annotation:** This collection contains abstracts of papers presented by Soviet and foreign scientists at the Eighth All-Union Conference on Space Biology and Aerospace Medicine (Kaluga, 25-27 June, 1986). The abstracts are divided into a number of areas: clinical-physiological research, psychophysiological aspects, metabolism and its regulation, problems of habitability, hygiene, and work capacity. The material in this collection should be of interest to specialists in space biology and aerospace medicine, including scientists working on ecological problems.

#### CONTENTS

(Numbers in parentheses refer to page numbers in the original.)

Foreword (3)

#### CLINICAL AND PHYSIOLOGICAL RESEARCH

Operational control of medical support during flight of visiting crew to "Salyut-7" OD Anashkin, et al. (5)

Diagnostic capabilities of the polarographic method for evaluating oxygen supply to tissues in patients suffering from acute myocardial infarction. AG Antropov, et al. (6)

A method for evaluating predisposition of the vascular system to spastic response. AG Antropov, YeA Kovalenko (7)

Correlation among values of stroke index, pulsation amplitudes in vessels of the lung, calf, digits and biochemical parameters measured using impedance plethysmography. AA Astakhov, et al. (9)

M117

Results of echocardiographic studies using a graded physical exercise test on a 237-day flight. OYu At'kov, GA Fomina (11)

State of central hemodynamics in members of the third prime crew of "Salyut-7" during an LBNP test. OYu At'kov, GA Fomina (11)

Mathematical analysis of cardiac rhythm as a means for evaluating the functional state of cosmonauts during EVA. RM Bayevskiy, et al. (12)

Investigation of mechanical cardiac activity in the initial period of adaptation to weightlessness using spatial ballistocardiography. RM Bayevskiy, et al.

Positive pressure breathing and physical conditioning for decreasing cardiovascular deconditioning in cosmonauts. U. Balldin (15)

Artificial increase in body hydration as a means of increasing human tolerance of  $+G_z$  acceleration. S. Baran'ski, et al. (17)

Development of means for optimizing protection of operators' heads from impact. AS Barer (18)

Cytogenetic studies of human blood during exposure to long-term hypokinesia. NN Bobkova, TN Krupina (20)

Experimental model for the study of physiopathologic aspects of the development of acute life-threatening states and development of reanimation techniques for use under specific circumstances. VV Bogomolov, et al. (21)

Measures taken to accelerate recovery after long-term flights in a health spa in the city of Kislovodsk. VV Bogomolov, VA Tkachenko (22)

Emergency medical care on manned space flights. VV Bogomolov (23)

Possibility of rehabilitating pilots with functional disorders using occupational provocative tests. VA Bodrov, VV Kharin. (25)

Results of impedance cardiographic measurements in space flight. F. Beysh (27)

Change in intracardiac hemodynamics in response to excess pressure in the lower body of humans. VV Bystrov, et al. (27)

Future prospects for use of long-term epidural anaesthesia on long-term space flights. AV Babishchevich (29)

External counterpulsation as a possible means for preventing orthostatic hypotonicity during the acute period of readaptation. TD Vasil'yeva, et al. (30)

The use of spiroergometric vita-maxima investigations in functional-medical examinations of flight crews. D. Virt, V. Papenfus (31)

M117

Pharmacological prevention of bone changes in hypokinesia and hypodynamia. AI Volozhin, et al. (31)

Effectiveness of rehabilitation measures in cardiovascular disease in civil aviation flight crews. BL Gel'man (33)

Cardiovascular responses in individuals differing in their tolerance of hypergravity. GD Glod, et al. (34)

Problems of ecological and gravitational biophysics. AA Glushko (35)

A method for evaluating thermal status in humans. LG Golovkin (36)

The effect of voluntary control of respiration on the functional state of the cardiovascular system under conditions of hypoxia. YeP Gora (38)

Study of parameters of the oxygen transport function of the blood in hemodialysis during a 14-day period of hypokinesia with head-down tilt (angle of  $-8^{\circ}$ ). IB Goncharov, VF Ivchenko (39)

Determining need for drugs during flights varying in duration. IB Goncharov, et al. (41)

The problem of homeostasis in space anthroecology. AI Grigor'yev, YA Kovalenko (42)

Evaluation of the effects of weightlessness on the work capacity of the muscle system of the arms. LS Grigor'yeva, et al. (45)

Experimental and theoretical studies of hemodynamics in weightlessness simulation. RD Grigoryan, et al. (46)

The effectiveness of hypokinesia as a simulation of space flight. P Groza, A Bordeyanu (48)

The effect of a 3-day period of immersion hypodynamia on maintenance of a vertical posture and vestibulomotor response in humans. VS Gurfinkel', et al. (48)

Physiometric evaluation of meteorotropic responses. VV Guzeyev, et al. (49)

Stress in pilot jobs under varying levels of automation in control of aircraft and helicopters. AB Vasil'yev, VYa Kolyagin (52)

Use of excess pressure for increasing pilot tolerance for  $+G_z$  acceleration. Yu. Domashchuk. (53)

Study of hemodynamic response to exercise tests in flight crews with cardiorespiratory disease. GI Dorofeyev, et al (54)

Changes in venous pressure during a 120-day period of hypokinesia. VG Doroshev (56).



M117

- The effect of flight across time zones on diurnal rhythms in human work capacity. SM Zhuzhgin, TM Semeshina (56)
- Skin sensitivity to medium-frequency ultraviolet radiation under conditions of fluid shifts to the upper body with varying levels of illumination. IV Zubkova, LV Gutorova. (57)
- Mechanisms underlying changes in major body functions in humans undergoing long-term exposure to weightlessness. AD Yegorov. (58)
- Space and biospheric aspects of medical-ecological monitoring in diseases of the respiratory organs. NR Ivanov, et al.. (60)
- Omega potential -- a reliable means for operational monitoring and tracking of the dynamics of human reserve capacities. MI Ivanus, et al. (62)
- Functional changes in the human cardiovascular system during exposure to head-down tilt at various angles. SL Il'ina, VV Sabayev (63)
- The potential use of ultraviolet irradiation of the blood in the practice of space medicine. VA Il'in, et al. (64)
- Quantitative evaluation of decompression air embolism. LR Iseyev, et al. (65)
- Investigation of the reactions of cosmonauts' circulatory systems to a two-stage bicycle ergometer provocative test during a 237-day flight. OG Itsekhovskiy, et al. (66)
- Evaluation of the pumping and contractile functions of the left cardiac ventricle in humans exposed to weightlessness simulations. RT Kazakova, VP Katuntsev (68)
- The recreational ecosystem -- from industrial design to space tourism. LA Kalinkin, et al. (69)
- Central circulation, acid-base balance and oxygenation of the blood in a healthy human during a 7-day period of immersion. VYe Katkov, et al. (70)
- The effect of electromyostimulation on certain muscle contraction parameters after immersion hypokinesia. VG Kozlova, YeA Il'inskaya (72)
- Characteristics of cardiac relaxation in upright position. VA Komissarov (73)
- The effect of altered mechanical factors on the body. VI Kopanev (75)
- The effect of weightlessness on vestibular and vestibulo-eye movement reactions. LN Kornilova, et al. (76)
- Study of bioelectric cardiac activity in members of "Salyut-7 - Soyuz" prime and visiting crews during insertion and reentry. AR Kotovskaya, et al. (78)

M117

Acceleration tolerance in older individuals with health problems before and after simulated weightlessness. AR Kotovskaya, et al. (79)

The role of the visual system in vestibular reactions. IS Krikun (80)

Characteristics of cardiovascular response to physical exercise in older individuals under normal conditions and after hypokinesia and immersion. TN Krupina, LA Fotina. (81)

Measurement of body temperature behind the ear -- an integral method for use in extreme conditions. YeI Kuznets (83)

Submaximal values of human body temperatures measured behind the ear under conditions of impeded heat exchange. YeI Kuznets, et al. (84)

Quantitative study of publications in aerospace medicine. VA Kurashvili, et al. (84)

The problem of vestibular physiology in aerospace medicine and prospects for its solution. EV Lapayev, OA Vorob'yev (85)

The function of immunologically competent cells which produce the osteoclast-activating factor in subjects undergoing long-term hypokinesia and patients with osteoporosis. AT Lesnyak, et al. (87)

Correction of the intestinal microflora of individuals exposed to extreme conditions. NN Liz'ko, et al (88)

Evaluation of the effects of barometric pressure on the action of carbon monoxide. VG Litau, VI Belkin (89)

Characteristics of blood circulation in humans exposed to long-term hypokinesia with head-down tilt. VI Lobachik, et al. (89)

Bioelectric activity of the brain in high altitude hypoxia. VB Malkin, NF Landukhova (91)

Investigation of older individuals' capacity to adapt to prolonged exposure to hypercapnia. GA Manovtsev (92)

Vestibular tolerance and susceptibility to motion sickness. SS Markaryan, YuA Korotkov (93)

Changes in the body induced by long-term exposure to vibration on the job. L Markevich (94)

Evaluation of the effectiveness of vestibular, optokinetic and optovestibular stimulation in the development of experimental motion sickness. EI Mantsev, et al. (95)

Immunological shifts in the course of adaptation to high altitude hypoxia. MM Mirrakhimov, et al. (96)

M117

The role of heightened production of thrombin in the mechanism underlying myocardial damage in hypokinesia. (97)

The effect of flights across several times zones on the functional states of flight crews in civil aviation. KK Nesteruk, et al. (98)

Prospects for use of sorption methods of detoxification in special conditions. IP Neumyvakin, et al. (100)

Principles for evaluating the results of dynamic electrocardiography in the readaptation period following space flight. GA Nikulin, et al. (101)

Body impedance as a criterion in evaluating functional capacities of the human body. VE Pal'chikov, AS Osenniy (102)

Perspiration as one of the parameters of human tolerance of redistribution of blood to the lower body. NE Panferova, et al. (104)

Use of mathematical models of the spinal column to predict tolerance of impact acceleration VKh Petlyuk, et al. (105)

The effect of psychotropic drugs on orthostatic tolerance. EB Petrova (106)

Mathematical analysis of cardiac rhythm in individuals differing in susceptibility to motion sickness. BI Polyakov, et al. (108)

The potential use of laser refractometry for selection of candidates for civil aviation academies. NA Prudkiy, et al. (109)

Determining type of autoregulation of the cardiovascular system of pilots in flight certification. NA Razsolov, LI Pokotilo (110)

Results of multifactor spirocardioergometric measurements in pilots varying in age. P. Remesh, et al. (111)

Characteristics of vestibulo-eye movement interactions under conditions of unilateral multipolar stimulation of the labyrinths by a galvanic current. AA Repin (112)

Change in the tonic component of the galvanic skin response in response to provocative tests. AA Repin, YuA Solv'yev (114)

Local hypothermia in treating acute illness of the organs of the abdominal cavity in the practice of space medicine. AN Romanov, IV Vladimirov (116)

Adaptive responses of the coagulation system under altered gas composition of the atmosphere. VS Sverchkova, GD Pak (117)

Local skin circulation in humans exposed to increasing hypoxia. VN Semenov, et al. (118)

M117

Effect of external factors on the immunoenzyme status of the body in normal individuals and those with nonspecific pulmonary diseases. VP Sil'vestrov, et al. (120)

Mechanism regulating relationships among intracranial fluid volumes under conditions of simulated and actual weightlessness. (121)

Methodological aspects of the theory of space gastroenterology. KV Smirnov (122)

Predicting the development of motion sickness in cosmonauts during space flight. FA Solodovnik (123)

Intracranial fluid dynamics under exposure to head-down tilt. VI Sokolov, AV Krasov (125)

Pharmacological correction of disturbances of cardiac rhythm. LL Stazhadze, et al. (126)

Ways to improve the system for providing medical aid on long-term space flights. LL Stazhadze (128)

Biorhythmic aspects of occult forms of motion sickness. SI Stepanova (128)

Reserve capacities of the statokinetic functional system in prevention of motion sickness in weightlessness. PI Syabro (130)

Energy aspects of functioning of biological systems in a gravitational field. MG Tairbekov (132)

Study of the effects of large  $+G_z$  acceleration on human performance. VM Tardov, et al. (133)

Antioxidants as a means of protection in exposure to hypobaric and other types of hypoxia. UM Tilekeyeva, et al. (135)

Tolerance of decompression of the lower body in women. YeP Tikhomirov, et al. (136)

Study of parameters of superslow activity of the human brain in emotional stress as applied to the goals of space medicine. VV Tkachev, GD Reushkina (138)

Changes over time in immunological blood parameters in healthy individuals during adaptation to high altitudes and physical exertion. VK Tobkan', et al. (139)

Ecological aspects of air transport processes. VF Tokarev, VM Kotlyar (140)

Effect of hypokinesia on bone tissue. LA Triftanidi (141)

Results of electrocardiographic examination of "Salyut-7 - Soyuz" prime crews. VD Turbasov, et al. (144)

M117

Retrospective study of the health of flight crews in civil aviation. AS Turetskaya et al. (144)

The effect of hypodynamia and hyperglycemia on hemodynamics. ND Ustimova (145)

Characteristics of cardiac biomechanics in flight crews. VN Fatenkov, et al. (146)

Hypodynamia - the leading risk factor in the development of arteriosclerosis. IV Fedorov (148)

The effect of "dry" immersion on the cardiovascular system of individuals with borderline arterial hypertension. IO Fomin, SM Belyayev (149)

The study of the functional capacities of the cardiorespiratory system in patients exposed to a 30-day period of hypokinesia with head-down tilt. LA Fotina, VA Gornago (149)

Prospects and trends in the development of space ecology. VI Fofanov (151)

Prelaunch physiological reactions in flight crews as a physiological index of their professional readiness. NI Frolov (152)

The study of the characteristics of decompression gas formation under conditions simulating weightlessness. VI Chadov, et al. (154)

Performance of yoga exercises on manned space flights. RS Chatterjee, et al. (155)

Use of contrasting thermal stimulation to improve pilot performance. VYu Cheprasov (156)

Age characteristics of postural stability under normal conditions and after hypokinesia with head-down tilt. KhKh Yarullin, MV Sazonova (158)

On the participation of the endogenous opioid system in the genesis of vestibuloautonomic disorders in motion sickness, VV Yasnetsov, VS Shashkov (159)

#### PSYCHOPHYSIOLOGICAL ASPECTS

Principal approaches to evaluating flight skills. BS Alyakrinskiy (161)

Prospective uses for a test containing myokinetic psychodiagnostics. NZ Bondareva (162)

Psychotherapeutic aspects of prevention and restoration of functional disturbances in a flight crew. LP Grimak, VM Zvonikov (163)

The effect of long-term sensory monotony on multilevel psychological processes. SV Yegorov, et al. (164)

M117

The Luscher test as a quick method for evaluating functional state. VA Yegorov, BS Frantsen (165)

Voluntary self-regulation as one of the factors in adaptation of professionals to special working conditions. OI Zhdanov, YuA Shpatenko (166)

The effect of a 36-hour period of continuous performance on sleep in an individual undergoing isolation. OP Zhukova, IP Ponomareva (168)

Psychophysiological aspects of performance motivation. GM Zarakovskiy, VI Savchenko (170)

Major requirements for methods and criteria in evaluating psychological work capacity. KK Ioseliani, et al. (171)

Effect of nootropic [new Soviet term for substances "activating the integrative mechanisms of the brain, stimulating learning, improving memory and cognitive function; improving cortico-subcortical linkages"] drugs on functional state during adaptation to stressful operator's work. VI Kalozha (173)

A new psychophysiological approach to evaluation of visual-cognitive reliability of pilots and cosmonauts. KH Kammel', V Papenfus (175)

Characteristics of aesthetic perception in adaptation to altered ecopsychological conditions. OP Kozerenko, IM Ragorodskaya (177)

An investigation of the structural characteristics of cooperative work. VV Kozlov, LT Landorenko (177)

Significance of psychological stability under conditions of prolonged emotional stress. GI Kozlov, et al., (178)

Diurnal periodicity of psychomotor reactions and speech parameters of individuals working on a non-24 hour schedule. TB Kolinichenko, et al. (179)

Use of the second-signal information processing model of flight activity in the practice of aviation medicine. GL Komendantov, et al. (180)

Psychophysiological evaluation of student performance during conduct of exercises on a simulator and the Mi-8 helicopter. FD Konnov, et al. (181)

Role of cholinergic systems in regulation of memory trace retrieval and brain function under conditions of hypoxic hypoxia. VA Krayz, et al (183)

Use of a systems approach in psychological evaluation of information display devices. VV Lapa, et al. (184)

Certain characteristics of visual perception of objects observed through the windows of flight vehicle cabins. AV Lekarev (186).

M117

Control of psychophysiological state of a pilot during job performance. SG Mel'nik, AV Shakula (187)

Psychological work capacity during hypokinesia with head-down tilt as a function of individual emotional characteristics. YeYu Medvedeva (188)

Cooperative activity and the dynamics of intergroup interactions in shared isolation. MB Miroshkhina, AD Sled' (189)

Performance efficiency of operators varying in age during short-term exposure to hypercapnia. VI MYasnikov, et al. (190)

On the potential of methods used to study psychological work capacity (based on results of research on "Salyut-7"). AP Nechayev, et al. (191)

Specifics of the effects of individual environmental factors on acoustic characteristics of speech. AV Nikonov. (193)

Future directions in improvement of professional selection of pilots. BL Pokorovskiy, VM Zvonikov (194)

GABA derivatives: types of action and methods of evaluation with respect to the goals and requirements of psychopharmacology. LG Polevoy. (195)

Individual style in performance of sensorimotor tasks under different thermal regimens. IE Ponomareva, et al. (197)

Psychophysiological characteristics of perception of information from a television screen while controlling a moving object. VA Ponomarenko, et al. (199)

On certain psychological mechanisms underlying spatial disorientation in the cabin of a flight vehicle. VA Ponomarenko (199)

Individual characteristics of psychological regulation of performance in a risk situation. AI Refyakin (201)

Psychological training of operators to increase their performance stability in emotionally charged situations. YuA Senkevich, et al. (202)

Development and prospects for further improvement of a system of psychophysiological occupational selection in civil aviation. GL Strongin (203)

Effect of background music on the psychophysiological state and performance level of an operator under conditions of isolation. IB Stupnikov (204)

Stimulation of adrenergic structures as a method for controlling the psychophysiological state of a human operator. SI Sytnik, et al. (205)

On the effects of stress on systemic and regional hemodynamics. BM Fedorov, et al. (207)

M117

Effect of space flight on the characteristics of pursuit tracking. LS Khachatur'yants, et al. (208)

Results of research on the psychological work capacity of Salyut-6 and -7 crewmembers in space. Ya Khideng, et al (209)

Mechanisms underlying mobilization of physiological reserve capacities under conditions of heightened motivation. TN Tsoneva, et al. (209)

Comparative evaluation of the effectiveness of certain therapeutic and prophylactic methods on the asthenic syndrome. Ye A Shaposhnikov, et al (211)

Phenomenon of group synchronization of biological rhythms in single and double work. AI Shchukin (212)

#### HABITABILITY AND HYGIENE

Prospects for using nontraditional sources of food in human biological life support systems. IA Abakumova, et al. (214)

Major goals in the study of biologically active trace components of the atmosphere. BV Anisimov (215)

Experimental investigation of the potential for increasing the autonomy of mass exchange in the higher plant component of an artificial ecological system. YuA Berkovich (217)

Maintaining the cleanliness of the skin of cosmonauts using regenerated water. AA Berlin, et al. (218)

Hygienic approaches to evaluating safety during performance of technological experiments in space. YuP Bizin, RI Bogatova (219)

Nutrition of cosmonauts on the three "Salyut-7" prime crews. VP Bychkov, et al. (220)

Medical significance of "human - microorganisms" ecological systems in hermetically sealed living spaces. AN Viktorov (221)

Comprehensive techniques for investigating the state of the oral cavity and skin of operators. AN Viktorov, et al. (222)

Conditions [leading to] the development of oxygen aggression? in evolution and multicellular pathology. AM Gerasimov, NV Delenyan (224)

The biological life support system as a tool for studying ecological links among living organisms. II Gitel'zon, et al. (225)

Principles governing formation of aerosol particles of anthropogenic origin in hermetically sealed living spaces. VP Gorshkov, et al. (226)



M117

Biological description of pathogenic staphylococci in interchange of microorganisms in humans living in hermetically sealed areas. VA Gorshkov, et al. (227)

Effect of various temperature regimens on gas emission of polymer materials. AI Gorshunova, et al. (228)

Characteristics of the microflora formation in inhabited hermetically sealed living spaces under conditions of altered gas composition of the atmosphere. YA Deshevaya, ND Novikova (230)

Effects of certain products of CELSS waste processing on the formation of microbial communities of higher plants. NA Drugova, et al. (232)

Larvae of house flies as utilizers of organic waste from CELSS. TV Yrofeyeva, et al. (232)

Ecological aspects of microflora formation in spacecraft cabins. SN Zaloguyev, et al. (233)

Certain aspects of changes in drug sensitivity of human automicroflora during space flight. VK Il'in, et al. (234)

Extreme ecological conditions and immunological homeostasis in healthy humans. IV Konstantinova, et al. (234)

Effect of a new sour milk product on the composition of intestinal microflora. SG Krivova, et al. (236)

Quantitative description of lactoflora of the digestive tract in "Salyut-7" crews. SG Jruviva, et al. (236)

Role of one-celled algae in the formation of the living environment in human CELSS. GI Meleshko, et al. (237)

Adaptive responses in different age groups to hypercapnia in hermetically sealed living quarters. LN Mukhamediyeva, et al. (239)

Experimental determination of the maximum acceptable concentration of carbon monoxide for humans during long-term (up to 12 hours) isolation in individual protection devices. LYu Nazarov, et al. (241)

Study of the conditions of mineral nutrition of spirulina with respect to closed life support systems for humans. YeK Nefedova. OG Livanskaya. (242)

Comprehensive Japanese study of the creation of closed life support systems. K. Nitta (243)

Significance of the problem of biostability of construction materials for closed living spaces. ND Novikova, et al. (245)

M117

Current use of electrifiability parameters to ensure safety of nonmetallic materials and ways to improve scientific approaches to this problem. AV Pavlov, TF Kharchenko (246)

Hygienic aspects of the development of systems for regenerating wash water. ZP Pakm et al. (247)

Hygienic standardization of chemical substances with dual effects. SS Pashin (249)

On the biological effects of atmospheric ions. FG Portnov, AB Shmidt (250)

Hygienic aspects of the gas composition of the atmosphere in hermetically sealed living spaces and human job performance. VP Savina, et al. (251)

Prospects for regulating the gas atmosphere of hermetically sealed environments. VP Savina (252)

Microclimate conditions during the flight of "Salyut-7." VP Savina, et al. (254)

Standardization of parameters of artificial human environments, taking account of changes over time. VI Savkin (255)

Increasing the hygienic reliability of regenerated water supply systems in spacecraft by monitoring water quality. VM Skuratov, et al. (257)

Sanitary-chemical aspects of microbiological destruction of polymer materials in hermetically sealed spaces. IN Surovezhin, YeA Deshevaya (258)

Effect of space flight factors on the functional activity of delayed T-lymphocyte-effector hypersensitivities. GP Teplinskaya (259)

Plant utilization of the liquid products of human waste processing in CELSS. YuI Shaydorov, et al. (260)

Effects of low temperatures on microflora regenerated from atmospheric condensate. (261)

## BIOLOGY

Functional, morphological, and anatomical changes in orchid shoots grown for 110 days in space. ZK Abilov, et al. (263)

Dynamics of central circulatory parameters and external respiration in monkeys during space flight. AM Badakva, et al. (263)

State of bone tissue in pregnant rats after a 5-day space flight on "Cosmos-1514" biosatellite, AV Bakulin, et al. (265)

Functional and morphological indicators of monkeys' adaptation to constant conditions of orthostatic position and walking upright. GS Belkaniya, et al. (266)

M117

- Regeneration in tritons in weightlessness. EN Grigoryan, et al. (268)
- Effect of weightlessness and hypergravity on the development of the skeleton of white rats in prenatal ontogenesis. LA Denisova, et al. (269)
- Reactions of rat cerebral neurocytes to exposure to vibration. VI Drobyshev, TP Stepanova (269)
- Use of higher plants for genetic monitoring during space flight. VP Zhvalikovakaya. (271)
- Prospects for the development of space biology. YeA Il'in, VV Antipov (273)
- Study of catecholamine levels and adrenergic receptors of rats after space flights on the "Cosmos" biosatellites. R Kvetnyanski, et al. (275)
- Biosynthesis of nucleic acids in spleen lymphocytes of rats during long-term exposure to extreme factors. GS Komolova, IA Yegorov (276)
- Effects of space flight conditions on developing plants. LN Kostina, et al. (277)
- Use of microwaves to normalize the permeability processes of serous membranes. LK Kotova, VN Golubev (278)
- Ultrastructure of the cerebellar cortex of rats exposed to altered gravitational force. IB Krasnov, et al. (279)
- Changes in blood pressure and blood flow rate in a monkey during space flight. VP Krotov, et al. (282)
- Effects of weightlessness on fluid-electrolyte homeostasis in pregnant rats and their offspring. YeA Lavrova, et al. (282)
- Composition of fecal lactoflora in monkeys. AA Lentsner, et al. (284)
- Concentration of nucleic acids and protein in the mother-fetus system in rats after space flight. VF Makeyeva, IA Yegorov (285)
- Effect of microgravity on morphological gravity receptors in Xenopus leavis. Y Noybert, et al. (286)
- Evaluation of the state of the skeletal muscles in monkeys exposed to weightlessness and its simulations. SA Ksuratova, et al. (287)
- Growth and development of Rana temporaria tadpoles after exposure to increased gravitational force. EA Oygenblik (288)
- Effect of gravity on animal cells and organisms. GP Parfenov (28(0
- Effects of space flight on organic components of connective tissue. I Pospishilova, M Pospishil (290)

M117

Comparative evaluation of hypoxic schedules as a short-cut conditioning device to increase thermal stability. SM Rasinkin, VM Dukhovic (291)

Morphological manifestations of adaptive responses in rats undergoing tail suspension as a simulation of weightlessness. AS Kaplanskiy, et al. (292)

Effects of short-term weightlessness on the functions of the skeletal muscles of pregnant rats and their offspring ("Cosmos-1514"). SA Skuratov, et al. (294)

Frequency of sex chromosome division failures under conditions of altered gravity. (AV Smirnova. (295)

Comparative analysis of the effects of phenamine (amphetamine) and derivative selenophen on "memory" and susceptibility to convulsions in animals. LL Stazhadze, et a. (296)

Study of population dynamics and age structure of chlorella after exposure to weightlessness. VN Sychev, TB Galkina (297)

Certain genetic effects in Drosophila exposed to space flight factors. LP Filatova (299)

Psychophysiology of emotions and psychopharmacology for correcting emotional stress in experiments on monkeys. AM Chirkov, et al. (300)

Certain accomodation changes in brain cells in response to acute hypoxia. MT Shaov (302)

Evaluation of the adaptive potential of higher nervous activity in monkeys as revealed by parameters of instrumental responses in experiments on "Cosmos" biosatellites. GG Shlyk, et al. (303)

#### RADIOBIOLOGY

Effect of multicharged galactic cosmic radiation ions on seeds of arabidopsis. VM Abrasoma, AM Mareniy (305)

Study of the effect of radiation factors on biological subjects (lettuce seeds) in flight experiments on "Salyut-6" and "-7." YuA Akatov, et al. (395)

Decrease in partial oxygen pressure in inhaled air and changes in radiation resistance in animals. IA Aleshin, et al. (307)

Cytogenetic damage in sex cells of mice irradiated with accelerated HZE particles. A. Bayrakova, et al. (308)

Preliminary results and future prospects in the study of the effects of microgravity on cell biology. M. Butey (309)

Evaluation of genetic radiation risk after exposure to photon irradiation. A V'glenov (309)

M117

Structural and metabolic analysis of certain radiation effects on the central nervous system of dogs under conditions of hypoxia and hyperoxia. BI Davydov (311)

Radio emission and microwaves: occupational and ecological risk. BI Davydov, VS Tikhonchuk (312)

Concept of radiation risk in setting radiation safety standards for space flight. YeYe Kovalev, VA Sakovich (314)

Possible mechanisms of energy transmission from galactic HZE tracks to biological tissue. YeYe Kovalev, OD Brill' (315)

Experimental studies of effects of impact waves on biological subjects as a means for estimating the radiation danger of HZE. YeYe Kovalev, et al. (316)

Study of the mutability of plants exposed to HZE in experiments on board "Salyut-6" and using an accelerator. LN Kostina, et al. (317)

Increased sensitivity of smooth musculature of the small intestine in a hypogeomagnetic environment. YeN Panasyuk, et al. (318)

Study of physical tolerance and activity of animals as a means of estimating physiological work capacity under exposure to radiation. NI Ryshov, et al. (319)

Radioelectric aspects of flights in low Earth orbit. VA Sakovich, et al. (321)

Mathematical modeling in setting radiation safety standards for space flights. VA Sakovich (322)

Recovery of parameters of peripheral blood and total number of cells in marrow after fractional gamma-irradiation. VA Ul'yanova, BA. Markalov (322)

Effect of the adaptation process on tolerance for extreme conditions. YuV Farber (324)

Remote biological effects of accelerated HZEs. BS Fedorenko (326)

Quantitative regularities in recovery processes in the spermatogenic epithelia of mice under conditions of repeated gamma-neutron irradiation. NL Fedorov, AV Shafirkin (327)

Possible role of the local radiation factor in space in development of the prerequisites for prebiotic evolution. SS Yurov, IG Akoyev (329)

Change in the level of ultraviolet fluorescence of human leukocytes in response to exposure to ionizing radiation. AS Yagunov. (329)

M117

## METABOLISM AND ITS REGULATION

Dynamics of EKG parameters and blood electrolytes in healthy individuals undergoing long-term hypokinesia. NP Artamanova, et al. (331)

Vitamin status in humans exposed to a 120-day period of hypokinesia with head-down tilt. MS Belakovskiy, et al. (332)

Quantitative and functional parameters of T-lymphocytes and activity of normal killer cells in subjects suffering from systemic osteoporosis or undergoing a 120-day period of hypokinesia with head-down tilt. NV Bozhikov, et al. (333)

Some approaches to development of biochemical criteria for tolerance of adverse factors of aircraft flight. SA Bugrov, et al. (334)

A case study in the use of mathematical models for evaluating the state of fluid-electrolyte metabolism. NG Vasil'yeva, et al. (336)

Some parameters of fluid-electrolyte metabolism in humans subjected to excess pressure on the lower body. LI Voronin, et al. (337)

Study of the link between change in bone mass and number of stemmed hemopoietic cells. ND Gol'dovskaya, VN Shvets (338)

Effect of diphosphonate on mineral metabolism and the state of bone tissue during long-term hypokinesia. AI Grigor'yev, et al. (339)

Biochemical parameters of adaptive physiological responses to various extreme factors. LG Yelkina (340)

Activity of a number of amino acid metabolic enzymes and the rate of gluconeogenesis processes in tissues of rats undergoing hypokinesia. SM Yershikov, et al. (341)

Erythrocyte metabolism in humans under conditions of long-term hypokinesia. SM Ivanova, et al. (342)

Effects of an artificial living environment in a hermetically sealed living space on certain metabolic parameters in humans. S Kalandarov, et al. (343)

Blood system reactions during adaptation to space flight. MP Kalandarova, et al. (344)

Investigation of the concentration of L-cystathionine in various locations in the brains of rats postflight in an experiment on the "Cosmos-1129" biosatellite. VYu Kovalev, AE Enes (345).

Role of food products and water in supplying trace elements to subjects living in a hermetically sealed environment. VA Kondratyuk (346)

Problems in space immunology. IV Konstantinova (348)

M117

Changes in volume of blood and liquid media in humans exposed to long-term hypokinesia with head-down tilt. VI Lobachik, et al. (349)

Evaluating the functional state of the musculoskeletal system in healthy men living in an isolated small group for a long period, as reflected in data on enzyme activity and mineral metabolism parameters. VV Makarovskiy, et al. (350)

Use of the drug "solism" to correct hydrolysis and lipid absorption in hypokinesia. IL Meckova, KB Smirnov (352)

Study of the effects of hypokinesia and stress on the fatty acid composition of erythrocytes. VP Naydina, et al. (353)

Fluid electrolyte metabolism and its hormonal regulation in long-term space flight. BV Afonin (354)

Role of ethan-1-hydroxy-1,1-diphosphoric acid in preventing osteoporosis in rats exposed to hypokinesia. AS Pankova, et al. (355)

Proteins and products of protein metabolism in blood under conditions of long-term hypokinesia. IA Popova, et al. (356)

Sulfur-containing amino acids in cosmonauts' blood plasma. IG Popov, AA Latskevich (357)

Criteria for evaluating the state of lipid metabolism in flight crews. VYe Potkin, et al. (358)

Physiological adaptation and correction of calcium metabolism under conditions simulating weightlessness. LB Prilipko (360)

Quantitative evaluation of mineralization of tubular bone in the calves of humans undergoing long-term hypokinesia with head-down tilt. AS Rakhmanov, et al (261)

Effects of an altered activity regimen on the state of nitrogen metabolism in humans. AK Sivuk, et al. (362)

Analysis of secretor processes in the gastrointestinal tract during long-term hypokinesia. KV Smirnov, et al. (362)

Predicting osteodystrophy resulting from long-term exposure to weightlessness. GP Stupakov, et al (364)

Carbohydrate and lipid metabolism parameters in rats repeatedly exposed to hypokinesia. NA Tikhomorova, PP Potabov (366)

Physiological mechanisms underlying the stages of adaptive erythropenic syndrome. AM Chayka, et al. (367)

Dynamics of blood volume, extra-cellular fluid, and serum protein weight in humans exposed to hypokinesia and immersion. AM Chayka, et al. (368)

M117

The nature of adaptive restructuring of neuroendocrine function in monkeys repeatedly exposed to emotional stress. AM Chirkov, et al. (370)

Activity of cytoplasmic NADP-dependent dehydrogenases in the liver and fatty tissue in rats during rehabilitation after a 15-day period of hypokinesia. TE Shilovskaya, PP Potapov (372)



**SPECIAL FEATURE:**  
**CHEMICAL NAMES OF SOVIET DRUGS REFERRED TO IN DIGEST ISSUES 1-13**

Soviet name: Cystamine dihydrochloride  
Chemical name: Bis-(beta-aminoethyl)-disulphide dihydrochloride  
General category: Radioprotector  
Digest Reference: Issue 2 Radiobiology: P89; Issue 9 Radiobiology: P398

Soviet name: Dibazol  
Chemical name: 2-Benzylbenzimidol hydrochloride  
General category: Spasmolytic, vasodilator, and hypotensive  
Digest Reference: Issue 2 Immunology: P79; Issue 6 Cardiovascular and Respiratory Systems: P240

Soviet name: Dihydroergotamin  
Chemical name: Dihydroergotamine Sulfonylmethane  
General category: Alpha-adrenoblocker  
Digest reference: Issue 10 Cardiovascular and Respiratory Systems: P434

Soviet name: Diprazin  
Chemical name: 10-(2-Dimethylaminopropyl)-phenothiazine hydrochloride  
General category: Antihistamine  
Digest Reference: Issue 4 Health and Medical Treatment: P169

Soviet name: Eufillin  
Chemical name: Theophyllin?? with 1,2-ethylenediamine (approximately 80:20)  
General category: Spasmolytic and vasodilator  
Digest Reference: Issue 4 Health and Medical Treatment: P169

Soviet name: Folicobalamin  
Chemical name: Cyanobalamin (50 ug) and folic acid (5 mg)  
General category: Vitamin  
Digest reference: Issue 11 Body Fluids: P450

Soviet name: Glivenol  
Chemical name: Ethyl-3,5,6-tri-O-benzyl-D-glucopyranoside  
General category: Sugar (antiinflammatory, antianaphylactic, analgesic, vasotonic)  
Digest reference: Issue 10 Cardiovascular and Respiratory Systems: P434

Soviet name: Imidazolin  
Chemical name: Identical to Phentolamine q.v.  
Digest Reference: Issue 6 Cardiovascular and Respiratory Systems P240

Soviet name: Indomethacin  
Chemical name: 1-(para-Chlorobenzoyl)-5-methoxy-2-methylindol-3-acetic acid  
General category: Nonsteroid antiinflammatory preparation  
Digest reference: Issue 4 Endocrinology: P146

Soviet name: Obzidan  
Chemical name: 1-1-Isopropylamino-3(1-naphthoxy)anol hydrochloride  
General category: Beta-blocker  
Digest Reference: Issue 3 Endocrinology: P96

Soviet name: Octadin  
 Chemical name: Beta-(N-Azacycloctyl)-ethylguanidine sulfate  
 General category: Beta blocker  
 Digest Reference: Issue 3 Endocrinology: P96

Soviet name: Phentolamin  
 Chemical name: 2-[N-para-tolyl-N-(meta-oxyphenyl)-aminomethyl]-imadозoline hydrochloride  
 General category: Alpha-Adrenoblocker  
 Digest reference: Issue 4 Health and Medical Treatment: P169

Soviet name: Propranolol  
 Chemical name: Identical to obzidan q.v.  
 Digest reference: Issue 5 Cardiovascular and Respiratory Systems: P206

Soviet name: Piracetam  
 Chemical name: 2-Oxo-pyrrolidinylacetamide  
 General category: Nootropic substance \*  
 Digest reference: Issue 10 Neurophysiology: P423

Soviet name: Potassium orotate  
 Chemical name: Potassium salt of urantsyl-4-carbonic acid  
 General category: Cholesterol/lipoprotein lowering substance  
 Digest reference: Issue 10 Neurophysiology: P423

Soviet name: Raunatin  
 Chemical name: Preparation containing all the alkaloids in the root of Rauwolfia plants.  
 General category: Neuroleptic  
 Digest Reference: Issue 4 Health and Medical Treatment: P169

Soviet name: Retabolil  
 Chemical name: 19-Nor-testosterone-17 beta-decanoat  
 General category: Anabolic  
 Digest reference: Issue 10 Musculoskeletal System: P422; Issue 11: Musculoskeletal System: P456

Soviet name: Sydnokarb  
 Chemical name: N-Phenylcarbamoyl-3-(Beta-phenylzopropyl)-sydnonimine  
 General category: Psychological stimulant  
 Digest reference: Cardiovascular and Respiratory Systems: Issue 5: P188; Issue 10 P434; Issue 11 Psychology: P456

\* Nootropic is a new Soviet term designating a class of drugs which "directly activate the integrative mechanisms of the brain, stimulating learning, improving memory and cognitive functioning, increasing the brain's tolerance of adverse stimuli, and improving cortico-subcortical linkages." As of 1984, piracetam was the only drug listed in this category. Nootropic substances have no noticeable influence on the spontaneous bioelectric activity of the brain, nor on motor reactions. They do not have soporific or analgesic effects. Even in large doses, they do not affect the peripheral nervous system. At the same time they affect a number of CNS functions; facilitating information transmission between the hemispheres, stimulating transmission of excitation in central neurons, improving brain blood supply and metabolism, and increasing tolerance of hypoxia.

CURRENT TRANSLATED SOVIET LIFE SCIENCE MATERIALS AVAILABLE TO OUR  
READERS

Translations and abstracts of recent Soviet publications, including those of interest to specialists in space life sciences, are published by Joint Publications Research Service (JPRS). There are three series of JPRS reports relevant to space life science: Series USB, Science & Technology, USSR: Space Biology and Aerospace Medicine includes a cover to cover translation of the Soviet journal Kosmicheskaya Biologiya i Aviakosmicheskaya Meditsina (8 issues per year); Series ULS, Science & Technology, USSR: Life Sciences, containing mainly short abstracts with some complete translations (20 issues per year); and Series USP, Science & Technology, USSR: Space, containing translations of newspaper reports, short abstracts, and translations (6 issues per year). Individual JPRS publications may be ordered from the National Technical Information Service (NTIS), 5285 Port Royal Road, Springfield, Virginia 22161. The phone number of NTIS is (703) 487-4600 and telephone orders are encouraged. Prices depend on number of pages; a recent issue of Space Biology and Aerospace Medicine, for example, cost \$16.00. When ordering, it is recommended that the JPRS number, title, date and author, if applicable, of publication be cited. An order takes 9-30 days to arrive. Rush orders are possible, but involve an additional charge. There is a significant and variable lag period between the time a JPRS publication is completed and the time it is orderable from NTIS.

As a service to our readers we will regularly provide publication information for relevant JPRS reports and cite the titles of articles selected as particularly relevant to NASA. Translations of titles are those of JPRS. JPRS entries marked with \* were previously abstracted by us. Readers should be aware that JPRS abstracts are considerably shorter and less detailed than Digest abstracts

JPRS REPORT  
SCIENCE AND TECHNOLOGY  
USSR: LIFE SCIENCES

JPRS-ULS-87-08      4 August 1987

Selected Contents:

Effects of Calcitonin and Retabolil on Rat Femur in Hypokinesia  
(Rogacheva, et al.; Abstract; 1 page)\* [Digest Issue 10]

Influence of Vibration and Hyperbaric Oxygenation on Brain Stem Reticular  
Formation in Animals (Nenashev, et al.; Abstract; 1 page)

Influence of High Temperature on Total Gas Metabolism of Animals with  
Limitation of Motor Activity (Kafizova; Abstract; 1 page)

Influence of Emotional-Pain Stress on Contractile Function of Myocardium  
During Long-Term Hypokinesia (Saulya; Abstract; 1 page)

Correction of Acute Hypoxia Induced Changes in Blood Coagulation in Rabbits  
(Balanskaya; Abstract; 1 page)

Systemic Hemodynamic Shifts in Hypoxia (Nurmatov, et al.; Abstract; 1 page)

Effects of Immobilization Stress on Megakaryocyte-Thrombocyte System in Mice (Meyerson, et al.; Abstract; 1 page)\* [Digest Issue 10]

JPRS REPORT  
SCIENCE AND TECHNOLOGY  
USSR: LIFE SCIENCES

JPRS-ULS-87-010

12 August 987

Selected Contents:

Effects of Ship's Rolling Motion on Fishermen's Sleep and Physiological Functions (Skrupskiy; Abstract; 1 page)

Individual Differences in Adaptation to Hypoxia and Cold Based on Emotional-Behavioral Criterion of Bodily Reactivity (Zagustina; Abstract; 1 page)

Effects of Bacterial Lipopolysaccharides on Hemopoiesis (Baranov; Abstract; 1 page)

ENGLISH REPORT ON SOVIET WORK ON PLANTS IN SPACE

An article entitled "Plants in Space," by Halstead and Dutcher, covering Soviet as well as Western work, was published in the "Annual Review of Plant Physiology," Volume 38, 1987. Requests for reprints should be addressed to F. Ronald Dutcher, Science Communications Studies, The George Washington University, Washington, DC 20037.



# Report Documentation Page

1. Report No. NASA CR-3922(16)		2. Government Accession No.		3. Recipient's Catalog No.	
4. Title and Subtitle USSR Space Life Sciences Digest - Issue 14				5. Report Date February 1988	
				6. Performing Organization Code	
7. Author(s) Lydia Razran Hooke, Ronald Teeter, Mike Radtke,* and Joseph Rowe,** Editors				8. Performing Organization Report No.	
				10. Work Unit No.	
9. Performing Organization Name and Address Lockheed Engineering and Management Services Co. 600 Maryland Avenue SW, Suite 600 Washington, DC 20024				11. Contract or Grant No. NASW-4292	
				13. Type of Report and Period Covered Contractor Report	
12. Sponsoring Agency Name and Address Office of Space Science and Applications National Aeronautics and Space Administration Washington, DC 20546				14. Sponsoring Agency Code EBM	
15. Supplementary Notes *RCA Government Services, Washington, DC **Library of Congress, Washington, DC					
16. Abstract  This is the fourteenth issue of NASA's USSR Space Life Sciences Digest. It contains abstracts of 32 papers recently published in Russian language periodicals and bound collections and of three new Soviet monographs. Selected abstracts are illustrated with figures and tables from the original. Also included is a review of a recent Soviet conference on Space Biology and Aerospace Medicine. Current Soviet life sciences titles available in English are cited. The materials included in this issue have been identified as relevant to the following areas of aerospace medicine and space biology: adaptation, biological rhythms, body fluids, botany, cardiovascular and respiratory systems, developmental biology, endocrinology, enzymology, equipment and instrumentation, gastrointestinal systems, habitability and environment effects, human performance, immunology, life support systems, mathematical modeling, metabolism, musculoskeletal system, neurophysiology, nutrition, operational medicine, perception, personnel selection, psychology, radiobiology, and space biology and medicine.					
17. Key Words (Suggested by Author(s)) space life sciences      flight simulations aerospace medicine      microgravity space biology psychology flight experiments				18. Distribution Statement  Unclassified - Unlimited  Subject Category 51	
19. Security Classif. (of this report) Unclassified		20. Security Classif. (of this page) Unclassified		21. No. of pages 110	22. Price A06

NASA FORM 1626 OCT 86 Available from the National Technical Information Service, Springfield, VA 22161

ORIGINAL PAGE IS  
OF POOR QUALITY

NASA-Langley, 19