

N88-16640

## RESULTS OF NASA/ARMY TRANSMISSION RESEARCH

John J. Coy  
Propulsion Directorate  
U.S. Army Research and Technology Activity - AVSCOM  
Lewis Research Center  
Cleveland, Ohio 44135

and

Dennis P. Townsend and Harold H. Coe  
National Aeronautics and Space Administration  
Lewis Research Center  
Cleveland, Ohio 44135

## SUMMARY

Since 1970 the NASA Lewis Research Center and the U.S. Army Aviation Systems Command have shared an interest in advancing the technology for helicopter propulsion systems. In particular, this paper outlines that portion of the program that applies to the drive train and its various mechanical components. The major goals of the program were (and continue to be) to increase the life, reliability, and maintainability, reduce the weight, noise, and vibration, and maintain the relatively high mechanical efficiency of the gear train. Major historical milestones are reviewed, significant advances in technology for bearings, gears, and transmissions are discussed, and the outlook for the future is presented. The reference list is comprehensive.

E-3422

## INTRODUCTION

Since 1970 the NASA Lewis Research Center and the U.S. Army Aviation Systems Command have shared an interest in advancing the technology for helicopter propulsion systems. In particular, this paper outlines the aspect of that program that applies to the drive train and its various mechanical components.

The NASA Lewis Research Center has had a strong research program for aircraft mechanical components since the early 1940's. A program for rolling element bearing technology for turbine engine application was built up during the 1950's and 1960's. Since many high-bypass turbine engines have a geared fan, in 1969 Lewis began a technology program for gear materials endurance. Meanwhile, during the period from the late 1940's to the late 1960's, the helicopter came into wide use as an Army air mobile vehicle. In 1970 the common interest of the Army and Lewis was recognized. The Army had a wide spectrum of helicopters in its inventory along with the requirement to increase their performance and NASA Lewis had established a capability in mechanical component research that could be applied to helicopter transmissions. A joint program was undertaken in 1970.

The major goals of the program were (and continue to be) to increase the life, reliability, and maintainability, reduce the weight, noise, and vibration, and maintain the relatively high mechanical efficiency of the gear train.

The purpose of this paper is to review and summarize the most significant results of the NASA/Army work on helicopter transmission technology. The major historical milestones are reviewed; significant advances in technology for bearings, gears, and transmissions are discussed; and the outlook for the future is presented. The reference list does not include every publication from the research that was completed, but it is comprehensive in that several of the cited references are themselves overview summary reports, and sources of complete listings of references at the time of their publication (refs. 1 to 5).

## PROGRAM OVERVIEW

### Mechanical Components Research

During the 1950's and 1960's NASA Lewis conducted research programs in mechanical components. Special attention was directed to bearings, seals, shafting, and lubricants for gas turbine engines, and space applications such as generators and launch vehicle components. Gear research began at NASA Lewis late in the 1960's and the Gear Fatigue Test Rigs were constructed. The work on gearing concentrated on materials and lubricants investigations and established a unique data base to be used for life prediction in aviation applications. In 1970 the Army Aviation Propulsion Laboratory of the Aviation Systems Command (AVSCOM) was established at NASA Lewis, and a joint NASA/Army program in mechanical components was initiated.

### NASA Helicopter Transmission Program

In 1977 NASA began a 6-yr, 7 million dollar program for helicopter transmission research for civilian and military helicopters. The program was coordinated with the Army and supported goals for major advances for transmissions in the following categories (fig. 1): (1) Life, Reliability, and Maintainability, (2) Weight, and (3) Noise and Vibration.

Significant achievements were made in advancing mechanical component and transmission system technology in the ensuing 6 yr. Advanced gear materials and lubricants were identified, unique test facilities for mechanical components and transmissions were constructed, a baseline of current technology was established, and existing designs were studied to determine power densities. Advanced technology for materials, lubricants, and components were integrated into an upgraded design for the OH-58 transmission to demonstrate the benefits inherent in such an approach. In addition, advanced transmission concepts were explored including traction drive, self-aligning bearingless planetary, and split torque. Several of those transmissions were built for test and evaluation using the NASA Lewis test stands.

During the 6-yr program on transmissions, an effort was begun in developing computer programs for component and system analysis for transmissions. The technical advances are discussed later in this paper.

### Current and Future Direction

Presently, the NASA program in helicopter transmission is emphasizing noise reduction technology. There is a small base effort in gearing

technology, consisting mainly of in-house research projects in lubrication, cooling, and materials. The noise reduction program is discussed in a companion paper presented in the session on helicopter noise.

An in-house and university grant effort continues to develop computer programs for analysis and design of transmission systems. The unique facilities and hardware resulting from the 6-yr program are being used to collect data to validate existing computer codes and subroutines for transmission system analysis is being assembled. The goal is to develop a comprehensive computer program library for transmission system modeling (fig. 2).

An important new initiative in transmissions by the Army will be conducted through the Propulsion Directorate, Aviation Research and Technology Activity (ARTA). A 5-yr program will begin in 1987 to develop advanced concept demonstrator transmissions for two categories of helicopters, the Advanced Cargo Helicopter (ACA), and the Future Attack Rotorcraft (FAX). The program will parallel the concept offered by engine demonstrator programs, and provide a way for the industry to develop advanced concepts and designs well in advance of critical needs. This is the first demonstrator program for transmissions. By request of the Assistant Secretary of the Army for Research, Development, and Acquisition, the program will address the issues of weight, noise, and reliability. The goals are to reduce weight by 25 percent, noise by 10 dB, and increase the meantime between removals (MTBR) to 5000 hr. The transmission program will build on the strong technology base from the joint NASA/Army programs as well as NASA's noise reduction research.

## SIGNIFICANT TECHNICAL ADVANCES

### Transmission Data Base Established

An extensive data base has been established for two sizes of helicopter transmissions (refs. 6 to 10). The Army's UH-60 Blackhawk transmission (fig. 3) has been run in the NASA Lewis test stand to determine thermal, vibration, stress, and efficiency information for a matrix of operating conditions. Figure 4 shows the measured efficiency as a function of input power, rotor speed, and oil inlet temperature. This information is being used to compare with computer code predictions for code validation and to provide a baseline from which to assess the promised advantages of future designs and concepts. Information of a similar nature and purpose was collected for the OH-58 transmission. The NASA Lewis test stands are currently operational and available for use in experimental transmission work.

### Gear Materials Technology

The heavy load and speed condition of helicopters and turboprop gearing require materials that have high strength and improved fatigue life at elevated temperatures. Several advanced gear materials and processes have been evaluated and they show promise for improved transmission (refs. 11 to 13).

Figure 5 shows the fatigue life obtained with four advanced materials or processes in comparison with baseline AISI 9310 gear steel. In each case a life improvement resulted.

The standard AISI 9310 gear fatigue life was improved by 60 percent (fig. 5) through shot peening of the gear flanks (ref. 11). The shot peening increased the subsurface residual compressive stress resulting in increased surface fatigue life.

Three high temperature materials have been evaluated for surface life and endurance at heavy test load and moderate speed conditions. The CBS 600 material maintains its hot hardness to 500 °F and has shown an improved fatigue life over that for AISI 9310 (ref. 12). The CBS 600 has good fracture toughness and is a good gear material for aircraft use.

The Vasco X-2 material retains its hardness to 600 °F and has shown improved fatigue life over AISI 9310 when it has been heat treated under very closely controlled conditions (ref. 12). Because the Vasco X-2 has a high chromium content it is very difficult to carburize and harden which means that high standards of quality control are required for aircraft applications. It also has a modest fracture toughness and can be subject to tooth breakage, precipitated at a fatigue spall.

The EX-53 gear material has shown the largest improvement in fatigue life (ref. 13). It has a fatigue life more than twice that of AISI 9310 and has very good fracture toughness. The EX-53 material has a temperature limit of 450 °F which limits its use for some high temperature applications.

#### Gear Lubricant Evaluation

Spur gear surface fatigue tests were conducted with five lubricants using a single lot of consumable-electrode vacuum melted (CVM) AISI 9310 spur gears. The gear were case carburized and hardened to Rockwell C 60. The gear pitch diameter was 8.89 cm (3.5 in.). The lot of gears was divided into five groups, each of which was tested with a different lubricant. The test lubricants can be classified as either a synthetic hydrocarbon, mineral oil, or ester-based synthetic lubricant. All five lubricants have similar viscosity and pressure-viscosity coefficients. Test conditions included a bulk gear temperature of 350 K (170 °F), a maximum Hertz stress of 1.71 GPA (248 000 psi) at the pitch line, and a speed of 10 000 rpm. A pentaerythritol base-stock without sufficient antiwear additives (lubricant C) produced a 10-percent surface fatigue life that was approximately 22 percent that of a pentaerythritol base stock of the same viscosity with chlorine and phosphorus type additives (fig. 4), (refs. 14 and 15). The presence of a sulfur type antiwear additive in the lubricant did not appear to affect the surface fatigue life of spur gears at the conditions tested. No statistical difference in the 10-percent surface fatigue life was produced, with four of the five lubricants having similar viscosity and pressure-viscosity coefficients and various antiwear additives.

These same lubricants and seven additional ones were run in an OH-58 transmission to determine the effect of lubricant type on mechanical efficiency. The efficiency varied between 98.3 and 98.8 percent (ref. 8). In a separate study, the chemical and physical properties were determined for the 11 lubricants used (ref. 16).

## Gear Thermal Behavior

Experimental testing and theoretical analysis have been conducted to determine optimum methods for gear lubrication and cooling. High-speed photography was used to study oil jet impingement depths for into-mesh, out-of-mesh, and radial oil jets (fig. 7). These were compared with analytical predictions of oil jet impingement depths. The analysis and tests show that there is limited impingement depth for into-mesh and out-of-mesh lubrication while radial jet lubrication with adequate oil jet pressure can provide maximum cooling and lubrication for gears (refs. 17 to 20). A thermal analysis was also performed and experimental verifications made which show the superior effect of radial oil jet lubrication and cooling.

## Gear Geometry

Gear geometry has been investigated (refs. 21 to 31). High contact ratio gears were examined as a means to improve the surface fatigue life, scoring load capacity, and power-to-weight ratio of transmissions. High contact ratio gears (HCRG) have at least two pairs of teeth in contact at all times, whereas standard (low) contact ratio gears (LCRG) have between one and two pairs in contact. Because the transmitted load is shared by at least two pairs of teeth, the individual tooth loading is less for HCRG than for LCRG designs, thereby enabling a higher power-to-weight ratio. HCRG, however requires finer pitches, or increased working depths; all of which tend to increase the tooth bending stress. In addition, it is expected that HCRG is more sensitive to tooth spacing errors and profile modifications because of the simultaneous tooth contacts. The basic problem to be resolved was whether the lower tooth loads occurring in the high contact ratio design more than offset the effects of the weakened tooth form, especially when run under dynamic load conditions. The investigation revealed that HCRG designs have twice the fatigue life of LCRG designs and slightly better scoring resistance. Therefore HCR gears can significantly increase life, reliability, and power-to-weight ratio for helicopter transmission (ref. 22).

Special attention has been directed to understanding the nature of the contact zone between gear teeth (fig. 8) (refs. 23 to 29). The contact between spiral bevel gears has been especially difficult to model because there are no equations with which one may represent the contact geometry; it must be developed numerically with a computer, based on the settings of the machine used to manufacture the gears. The contact geometry is essential to predicting the life, lubrication effects, and stress for spiral bevel gears. Kinematic errors have been identified as a contributor to gear mesh vibration (ref. 23). Kinematic errors are the time varying deviations from a constant gear ratio during gear rotation (fig. 9). A method for eliminating these errors has been developed (ref. 28) but the method still needs to be verified by experimental testing. These zero kinematical error gears have potential for reducing gear noise.

Straight and involute tooth shapes have been examined to determine the effect of speed on the stress and deflection of the teeth (ref. 30). The results of this analysis provide a criterion for defining the high-speed regime of operation for gears, where special analysis must be employed to predict dynamic loads. In reference 31, a procedure is given for designing minimum noise gears (spur gears), using a novel frequency domain approach.

## Bearing Technology

Progress in bearing technology is reported in references 32 to 41. Advances in materials and lubrication techniques have increased speed capacity, load capacity, and fatigue life.

The development of fracture tough bearing steels has increased the fatigue life of bearings (refs. 36 and 37). Without fracture tough steel, the hardened races of the bearings are too sensitive to crack propagation from fatigue nucleation sites. The M 50 NiL steel (ref. 37) is fracture tough but there is a continuing need for more corrosion resistance.

Lubrication techniques have been improved so that the bearing contacts are not starved and the bearing is properly cooled. This has lengthened the fatigue life and decreased wear as well as increased cooling of the bearing to enable high-speed operation (refs. 33 and 38 to 41).

The design and lubrication of large bore tapered-roller bearings for operation at speeds up to 2.4 million DN under combined radial and thrust loads has been demonstrated (ref. 41). (DN is a speed parameter equal to the product of shaft speed in rpm and diameter in millimeters.) The advanced bearing ran with less heat generation and ran cooler than the baseline bearing to which it was compared (fig. 10). It was also capable of higher speed operation--20 000 rpm compared to 15 000 rpm for the baseline bearing. In fatigue tests, four advanced bearings ran to 24 times rated catalog life without failure.

Tapered roller bearings offer advantages in reducing the total number of parts in a transmission. Often, several ball bearings and roller bearings can be replaced with tapered roller bearings (fig. 11). The reduction in parts count translates into increased reliability, but tapered roller bearings are sensitive to lack of adequate lubrication, especially at the roller ends that contact the ribs on the races. Research continues on tapered roller bearings to meet vulnerability resistance tests requiring 30 min of operation after loss of lubricant.

## Traction Drive Technology

During the years of the NASA Helicopter Transmission Technology program, there was significant progress in traction drives (refs. 3 and 42). A modern approach to life analysis was developed and applied to test models at NASA Lewis (fig. 12). Advanced materials and lubricants, combined with accurate analysis and prediction methods for life, efficiency, and traction coefficients made it possible to achieve high power transfer for experimental models. Traction drives are now capable of transmitting many horsepower, quietly and efficiently. Investigations showed that multiple, load-sharing contacts significantly benefit torque capacity and drive life. Torque capacity and drive life are proportional to size to the 2.8 and 8.4 power, respectively. Figure 12(b) shows the parametric variation of life with speed, torque, and power, where the life adjustment factors that come from lubricant film thickness as a function of speed have been factored in.

The drive shown in figure 12(a) was attached between a gas-turbine engine and a power absorption dynamometer and parametrically tested (ref. 42). Good

performance was achieved at speeds to 73 000 rpm and power to 180 kW. The peak efficiency was 94 to 96 percent, and there was only a 3.5 percent speed loss due to creep (microslip) of the rollers.

## ANALYTICAL DESIGN CODES

### Bearing Codes

The NASA/Army program has produced some very useful computer programs for designing and analyzing rolling element bearings (refs. 43 to 46). Generally, the computer programs can predict performance characteristics including Hertz stress, load distribution, lubrication film thickness, component kinematics, fatigue life, heat generation, operating temperature, and power loss as a function of input parameters such as bearing geometry, speed, and load. The programs permit better designs and eliminate much trial and error testing prior to selection of a final design. The various computer programs are for particular types of bearings as follows:

- (1) SHABERTH - Shaft bearing program, shaft load, and deflection with up to five bearings (ball, cylindrical roller, tapered roller) on shaft.
- (2) CYBEAN - Cylindrical roller.
- (3) PHERBEAN - Spherical roller.
- (4) PLANETSYS - Cylindrical or spherical roller in planetary system.

All of these programs are in the public domain and available through COSMIC (ref. 47).

A few examples will illustrate some of the capabilities of the bearing computer programs. In reference 48 the computer program SHABERTH was used to calculate the thermal performance of ball bearings for which sufficient test data were available to make a comparison over a range of test conditions. Three angular-contact ball bearings of differing sizes were selected. The variables used for comparison of experimental and calculated data were bearing temperatures, oil outlet temperatures, and bearing heat generation. The predicted bearing heat generation, inner and outer race temperatures, and oil outlet temperatures agreed very well with the experimental data obtained from three sizes of ball bearings (35, 120, and 167 mm bores) over a speed range from 1 to 3 million DN.

Figure 13 shows the comparisons as a function of shaft speed for the 120 mm bore bearing. The solid and dashed lines refer to two different assumptions for the amount of lubricant that enters the bearing cavity. Lubricant was supplied to the bearing cavity by feed holes at the split line of the inner race and to the running lands of the inner-race-riding cage. It was assumed that the minimum volume of oil in the cavity would result if none of the lubricant directed to the lands ever entered the bearing cavity, leaving the oil entering at the split line as the only source feeding the bearing cavity. At most it was assumed that only half of the lubricant supplied to the cage lands could enter the cavity. Hence the dashed lines and solid lines are an estimated maximum and minimum condition with respect to volume of oil in the bearing cavity.

In figure 13(d), the solid symbols represent power loss that was determined from a heat balance calculation on the oil flowing through the bearing. The open symbols represent power loss calculated by measuring the power used by the drive motor and subtracting a small amount of estimated tare loss. It is reported in reference 48 that the first method is the most accurate experimental method. Therefore, the solid symbols represent the better experimental measurements of power loss and the calculated power losses agrees well with the experimental data.

The good agreement of experimental and calculated data verifies the capability of computer program SHABERTH to calculate the thermal performance for ball bearings.

Computer program CYBEAN was used to calculate the thermal performance of a 118 mm bore cylindrical roller bearing with shaft speeds to 3 million DN (25 000 rpm), radial loads to 8900 N (2000 lb), and total lubricant flow rates to 0.0102 m<sup>3</sup>/min (2.7 gal/min). The calculations compared to the experimental data are shown in figure 14 (ref. 49).

Computer program PLANETSYS can simulate the thermo-mechanical performance of a multistage planetary transmission, including spherical roller bearings. SPHERBEAN can make calculations for outer-ring rotation and misalignment such as found in planetary transmission applications. These programs are useful for helicopter transmission applications where severe performance demands are placed on bearings that require analysis for outer ring rotation, for nonlubricated operation (dry friction) and for transient thermal performance. SPHERBEAN and PLANETSYS calculations were compared to data from parametric tests and loss-of-lubricant tests for an OH-58 transmission (ref. 50). Using both programs, calculations of temperatures at the output shaft and transmission case agreed with the data within 1-percent difference for steady-state operating conditions. Calculations to simulate the loss of lubricant compared well with data from an actual loss-of lubricant test on an OH-58 transmission (fig. 15).

#### Gear Codes

Analyses and/or computer codes have also been developed for gears to provide the following types of calculations (refs. 51 to 65): (1) power loss and efficiency, (2) bevel gear contact geometry, (3) gear dynamic analysis, (4) weight minimization, (5) life prediction, (6) lubrication, and (7) temperatures.

Figure 16 shows results of power loss calculations for high contact ratio gears compared to low contact ratio gears for two different sizes. The analytical method was developed from many existing methods and empirical data. It includes effects of sliding friction, elastohydrodynamic lubricant film thickness, windage, and rolling resistance. Using this method, the power loss and efficiency of spur gears and aircraft gear boxes may be predicted (refs. 51 and 52).

Computer program TELSGE (ref. 53) calculates dynamic loads, lubrication film thickness, stress, and temperature for spur gears. A similar program was developed for spiral bevel gears (ref. 54). Figure 17 (ref. 65) shows a sample calculation produced by TELSGE. The dynamic load is caused by the



interaction of the tooth stiffness and the mass of the gear. The figure compares the calculated dynamic load with the static load which is the load for very slow rotation of the gears.

Gear dynamic analysis computer programs have been developed for epicyclic gear systems (refs. 55 to 57).

Program PGT (ref. 55) calculates dynamic loads in a simple planetary assembly with three planet gears. A special feature of PGT is the determination of orbit motion for a floating sun gear.

The epicyclic gear program (refs. 56 and 57) is a multiple mesh/single stage, gear dynamics program. It is a versatile gear tooth dynamic analysis computer program which determines detailed geometry, dynamic loads, stresses and surface damage factors. The program can analyze a variety of both epicyclic and single mesh systems with spur and helical gear teeth including internal, external, and buttress tooth forms. The program includes options for flexible carrier or flexible ring gear, a floating sun gear, a natural frequencies option, and a finite element compliance formulation for helical gear teeth. The program can also determine maximum tooth loads as a function of speed which is useful for critical speed analysis. Figure 18 is a typical output of the program showing the sun planet dynamic loads for nine teeth passing through the contact zone.

At high speed, an important effect is the interaction of the gear tooth load with the mass and stiffness of the tooth itself. A computer code was developed to predict these effects (ref. 58). A computer code was also developed to consider the effect on dynamic load of the drive shaft stiffness and inertia of the connected loads (ref. 59).

Figure 19 shows the result of analysis for weight minimization (ref. 60). The problem was to determine the effect on weight of design parameters such as numbers and pitch of gear teeth. The weight of a spur gear pair is related to the center distance (fig. 19(a)); the smaller the center distance, the lighter the weight and for military applications, the smaller the size, the smaller is the vulnerability. The study produced a design chart (fig. 19(b)) which gives the allowable number of teeth on the pinion as a function of diametral pitch. Diametral pitch is the number of teeth per inch of diameter and is a measure of size. Smaller teeth have a large pitch number. The two design parameters cannot be selected without examining the limitations which are the criterion for pitting fatigue failure, bending failure and scoring. There is a geometry limitation also--involute interference, which is when the pinion teeth are badly undercut and involute action is lost. The figure shows that there is an allowed region for design (shaded area). The line C is the locus of designs which all have the same center distance, arrived at by different combinations of teeth number and pitch. The slope of the line is equal to the center distance. The minimum center distance design is on the lowest sloped line that has at least one point inside the shaded region.

Figure 20 shows results for life analysis of a planetary gear transmission. The analysis is based on rigorous statistical methods and is implemented in an interactive computer program (refs. 61 to 64). The program can analyze a variety of configurations composed of spiral bevel gear meshes

and planetary gear meshes. Spiral bevel reductions may have single or dual input pinions and gear shafts can be straddle mounted or overhung on the support bearings. The planetary reduction has the sun gear as input, the planet carrier as output, and the ring gear fixed. The planet gears may be plain or stepped and the number of planets may vary. The program determines the forces on each bearing and gear for a given transmission configuration and loading. The life of each bearing and gear is determined using the fatigue life model appropriate to that component. The transmission system life is determined from the component lives using Weibull statistical methods. The transmission life at a given reliability can then be found as shown in figure 20.

The life analysis has been integrated with a dynamic analysis (using computer program TELSGE), to determine the effect of speed on gear life (ref. 65). Figure 21 shows the result of the analysis, where the dynamic factor,  $C_v$ , represents the relative change in life due to dynamic loads. The static load, when applied in a quasi-static load cycle to the gear, will give a certain life which should be multiplied by  $C_v$  to get the life under dynamic load. There is a significant increase in life at speeds above the torsional natural frequency of the gear drive,  $\omega_n$ . Reference 65 gives design charts that may be used to calculate gear life for dynamic load conditions.

### ADVANCED TRANSMISSION DESIGN CONCEPTS

Based on the experimental, analytical, and design studies conducted under the transmission technology program, some advanced transmission concepts were evolved: The advanced 500 HP transmission (fig. 22), the bearingless planetary (fig. 23), the traction/gear hybrid transmission, (fig. 24), and the split torque transmission (fig. 25).

#### Advanced 500 HP Transmission

The design emphasis for the NASA/Bell Helicopter Textron (BHT) 500 HP advanced technology demonstrator transmission (fig. 22) was placed on designing a 500 HP version of the OH-58C, 317 HP, transmission that would have a long, quiet life with a minimum increase in the cost, weight, and space that usually increases along with power increases. This was accomplished by implementing advanced technology that has been developed during the last decade and making improvements dictated by field experience (ref. 66).

These advanced technology components, concepts, and improvements, and their effect on the 500 HP transmission are:

(1) High contact ratio planetary gear teeth reduce the noise level and increase life.

(2) Improved spiral bevel gears made of vacuum carburized gear steels, shot peened for increased gear tooth pitting fatigue life, as well as gear tooth bending fatigue strength, and lubricated with Aeroshell 555 oil save weight and space and increase transmission life.

(3) Improved bearings made of cleaner steels, and designed with improved analytical tools to save weight and space and increase the reliability.

(4) Improved design of the planet carrier made of two piece construction with straddle mounting of the planet gears for improved gear alignment and power capacity.

(5) The cantilever-mounted planetary ring gear has no working spline to generate wear debris; it isolates the meshing teeth from the housing to reduce noise; and it provides a flexible mount for a more uniform load distribution among the planets.

(6) The sun gear now has an improved spline (crown hobbled and hardened) running submerged in a bath of flowthrough oil which prevents the spline from wearing.

(7) The straddle-mounted bevel gear allows higher torque to be transmitted without detrimental shifting of the tooth contact pattern.

In summary, the improved 500 HP design has a weight/HP ratio of 0.26 lb/HP compared to 0.37 lb/HP for the 317 HP OH-58C transmission. This transmission is the basis for the transmission in the Army's improved OH-58D model helicopter.

#### Bearingless Planetary Transmission

One recent development in the area of high performance power transmissions is the self-aligning, bearingless planetary (SABP) (fig. 23). This transmission arrangement can be generically classified as a quasi-compound planetary which utilizes a sun gear, planet spindle assemblies, ring gears, and rolling rings.

The design study projects a weight savings of 17 to 30 percent and a reliability improvement factor of 2:1 over the standard transmission (ref. 67). The benefits of using a SABP transmission are most effective when one uses reduction ratios between 16:1 and 26:1. It permits high reduction in two compound stages of high efficiency, providing sufficient flexibility and self-centering to give good load distribution between planet pinions, while effectively isolating the planetary elements from housing deflections.

This new transmission concept offers advantages over transmissions that use conventional planetary gear: higher reduction ratio, lighter weight, increased reliability, and decreased vulnerability. Since it has no planet bearings, there is a weight savings and power losses and bearing failures commonly associated with conventional-design transmission are nonexistent.

In conventional-design transmissions, planet bearings are heavily loaded and are the weak link when the lubricant is interrupted. The SABP transmission has decreased vulnerability because of increased operating time after loss of lubricant since there are no planet bearings.

One SABP transmission with a 17.44:1 ratio is currently being tested in the 500 HP transmission facility at NASA Lewis, and another variant with a ratio of 101:1 is being fabricated for testing.

## Traction/Gear Hybrid Transmission

Two variants of this type of transmission have been fabricated as test models. The benefits of traction are combined with the benefits of gears in these novel transmission designs. In the version which simulates the OH-58 transmission (fig. 24), the hybrid transmission is only 22 percent heavier but transmits 58 percent more power. The transmission has advantages of increased power-to-weight ratio (0.27 lb/HP) and an estimated 300 percent increase in reliability. A high ratio variant, which eliminates a 40-lb gearbox on the engine offers an even higher advantage of 68 percent increase in power-to-weight ratio to 0.20 lb/HP.

## Split Torque Transmission

Advancements in transmissions can come from either improved components or improved designs of the transmission system. The split torque arrangement is in the second category. Figure 25 shows a split torque design which is compatible with the Black Hawk (UH-60A) helicopter. The fundamental concept of the split torque design is that the power from the engine is divided into two parallel paths prior to recombination on a single gear that drives the output shaft. Studies have shown that replacement of the planetary gear reduction stage with a split torque results in weight savings and increased reliability. There can be many pinions driving the output gear, but in the case of the UH-60A application it was found that four pinions gave the optimum design on the basis of least overall weight, reduced power losses, comparable total parts count compared to the existing UH-60 design, and least number (one) of nonredundant gears. The advantage of split torque over planetary is greatest for the larger sized helicopters.

The engineering analysis (ref. 68) showed that the following performance benefits can be achieved for a 3600 HP split torque transmission compared to the conventional transmission with a planetary gear stage:

- (1) Weight is reduced 15 percent.
- (2) Drive train power losses are reduced by 9 percent.
- (3) Reliability is improved and vulnerability is reduced because of redundant power paths.
- (4) The number of noise generation points (gear meshes) is reduced.

The transmission has potential for installation in the Black Hawk helicopter. The design study has carried the transmission to the detail design stage for a test model to be used for validation studies in the NASA Lewis 3000 HP helicopter transmission facility, but a test model has not been built. For the transmission to be used in the Black Hawk, a separate detail design and installation study would be required first.

## CONCLUDING REMARKS

The purpose of this paper has been to review significant developments in helicopter transmission technology as a result of the NASA/Army Transmission

Research Program of the last two decades. The helicopter demands an extremely light, long-lived and quiet drive system. The NASA/Army research, along with the helicopter builders' careful designs, has provided reliable and strong drive systems for civilian and Army helicopters. This paper has reviewed significant research in drive systems and their components.

The critical issues that were identified are: (1) to achieve significant advances in power-to-weight ratio, (2) to increase reliability, and (3) to reduce the transmission noise. New concepts to achieve these goals have been investigated. The advanced 500 HP transmission has explored an increased power-to-weight ratio using advanced design techniques, component improvements, and advanced materials. The value of this kind of research activity was realized during the upgrading of the Army's OH-58 helicopter, when the research on the advanced 500 HP transmission laid the groundwork for the transmission used in the D model. The split torque concept offers significant weight savings for large size helicopters. The bearingless planetary transmission with helical gears offers advantages in reliability and reduced noise. The traction/gear hybrid transmission has explored the advantage of noise reduction and reduced cost.

It is reasonable to expect that helicopters will continue to evolve in the future. To achieve the necessary advances in rotary wing flight capability, drive train technology must keep pace with advances in engines, controls, structures, and rotors. The current plan for NASA/Army Transmission Research calls for increased emphasis on noise reduction, an aggressive development of computer aided design codes for transmissions, and the design and construction of demonstrator transmissions in large and small size categories.

#### REFERENCES

1. Zaretsky, E.V.; Townsend, D.P.; and Coy, J.J.: NASA Gear Research and Its Probable Effect on Rotorcraft Transmission Design. NASA TM-79292, 1979.
2. Zaretsky, E.V.; Coy, J.J.; and Townsend, D.P.: NASA Transmission Research and Its Probable Effects on Helicopter Transmission Design. NASA TM-83389, AVRADCOM TR 83-C-3, 1983.
3. Advanced Power Transmission Technology. G.K. Fischer, ed. NASA CP-2210, AVRADCOM TR 82-C-16, 1983.
4. Weden, G.J.; and Coy, J.J.: Summary of Drive-Train Component Technology in Helicopters. NASA TM-83726, USAAVSCOM TR-84-C-10, 1984.
5. Coy, J.J.; Townsend, D.P.; and Zaretsky, E.V.: Gearing. NASA RP-1152, AVSCOM TR 84-C-15, 1985.
6. Townsend, D.P.; Coy, J.J.; and Hatvani, B.R.: OH 58 Helicopter Failure Analysis. NASA TM X-71867, 1976.
7. Lewicki, D.G.; and Coy, J.J.: Vibration Characteristics of the OH 58A Helicopter Main Rotor Transmission. NASA TP (in process), 1987.
8. Coy, J.J.; Mitchell, A.M.; and Hamrock, B.J.: Transmission Efficiency Measurements and Correlations with Physical Characteristics of the Lubricant, NASA TM-83740, USA AVSCOM TR 84-C-11, 1984.
9. Mitchell, A.M.; Oswald, F.B.; and Schuller, F.T.: Testing of YUH-61A Helicopter Transmission in NASA Lewis 2240-kW (3000 hp) Facility. NASA TP-2538, 1986.

10. Mitchell, A.M.; Oswald, F.B.; and Coe, H.H.: Testing of UH-60A Helicopter Transmission in NASA Lewis 2240-kW (3000 hp) Facility. NASA TP-2626, 1986.
11. Townsend, D.P.; and Zaretsky, E.V.: Effect of Shot Peening on Surface Fatigue Life of Carburized and Hardened AISI 9310 Spur Gears. NASA TP-2047, 1982.
12. Townsend, D.P.; and Zaretsky, E.V.: Endurance and Failure Characteristics of Modified VASCO X-2, CBS 600 and AISI 9310 Spur Gears. J. Mech. Des., vol. 103, no. 2, Apr. 1981, pp. 506-515.
13. Townsend, D.P.: Surface Fatigue Life and Failure Characteristics of EX-53, CBS 1000M, and AISI 9310 Gear Materials. NASA TP-2513, 1985.
14. Scibbe, H.W.; Townsend, D.P.; and Aron, P.R.: Effect of Lubricant Extreme-Pressure Additives on Surface Fatigue Life of AISI 9310 Spur Gears. NASA TP-2408, 1984.
15. Townsend, D.P.; and Zaretsky, E.V.: Effect of Five Lubricants on Life of AISI 9310 Spur Gears. NASA TP-2419, 1985.
16. Present, D.L., et al.: Advanced Chemical Characterization and Physical Properties of Eleven Lubricants. (AFLRL-166, Army Fuels and Lubricants Research Lab.; NASA Order C-67295-D), NASA CR-168187, 1983. (Avail. NTIS, AD-A131945.)
17. El-Bayoumy, L.E.; Akin, L.S.; and Townsend, D.P.: An Investigation of the Transient Thermal Analysis of Spur Gears. Journal of Mechanisms, Transmissions, and Automation in Design, vol. 107, no. 4, Dec. 1985, pp. 541-548.
18. Akin, L.S.; and Townsend, D.P.: Lubricant Jet Flow Phenomena in Spur and Helical Gears with Modified Center Distances and/or Addendums - for Out-of-Mesh Conditions. Journal of Mechanisms, Transmissions, and Automation in Design, vol. 107, no. 1, Mar. 1985, pp. 24-30.
19. Akin, L.S.; and Townsend, D.P.: Into Mesh Lubrication of Spur Gears with Arbitrary Offset Oil Jet. Part 1; For Jet Velocity Less than or Equal to Gear Velocity. Journal of Mechanisms, Transmissions, and Automation in Design, vol. 105, no. 4, Dec., 1983, pp. 713-718.
20. Akin, L.S.; and Townsend, D.P.: Into Mesh Lubrication of Spur Gears with Arbitrary Offset Oil Jet. Part 2; For Jet Velocities Equal to or Greater than Gear Velocity. Journal of Mechanisms, Transmissions, and Automation in Design, vol. 105, no. 4, Dec. 1983, pp. 719-724.
21. Townsend, D.P.; Baber, B.B.; and Nagy, A.: Evaluation of High-Contact-Ratio Spur Gears with Profile Modification. NASA TP-1458, 1979.
22. Frint, H. K.: Design and Evaluation of High Contact Ratio Gearing. NASA CR-174958, 1986.
23. Litvin, F.L.; and Coy, J.J.: Spiral Bevel Geometry and Gear Train Precision. Advanced Power Transmission Technology, G.K. Fischer, ed. NASA CP-2210, AVRADCOM-TR-82-C-16, 1983, pp. 335-344.
24. Litvin, F.L.; Rahman, P.; and Goldrich, R.N.: Mathematical Models for the Synthesis and Optimization of Spiral Bevel Gear Tooth Surfaces. NASA CR-3553, 1982.
25. Litvin, F.L., et al.: Synthesis and Analysis of Spiral Bevel Gears. Design and Synthesis, H. Yoshikawa, ed., North Holland, New York, 1985, pp. 302-305.
26. Litvin, F.L.; Tsung, W-J.; and Coy, J.J.: Generation of Spiral Bevel Gears with Zero Kinematical Errors and Computer Aided Simulation of their Meshing and Contact. Computers in Engineering 1985, R. Raghavan and S.M. Rohde, eds., vol. 1, ASME, New York, 1985, pp. 335-339.

27. Litvin, F.L., et al.: Method for Generation of Spiral Bevel Gears with Conjugate Gear Tooth Surfaces. ASME Paper 86-DET-3, 1986.
28. Litvin, F.L., et al.: Generation of Spiral Bevel Gears with Zero Kinematical Errors and Computer Aided Tooth Contact Analysis. NASA TM-87273, USAAVSCOM TR 86-C-2, 1986.
29. Litvin, F.L., et al.: New Generation Methods for Spur, Helical, and Spiral-Bevel Gears. USAAVSCOM TR-86-C-27, NASA TM-88862, 1986.
30. Lin, H.H.; Huston, R.L.; and Coy, J.J.: Dynamic Analysis of Straight and Involute Tooth Forms. ASME Paper 84-DET-226, Oct. 1984.
31. Mark, W.D.: The Transfer Function Method for Gear System Dynamics Applied to Conventional and Minimum Excitation Gearing Designs. NASA CR-3626, 1982.
32. Parker, R.J.: Present Technology of Rolling-Element Bearings. Advanced Power Transmission Technology, G.K. Fischer, ed., NASA CP-2210, AVRADCOM TR 82-C-16, 1983, pp. 35-48.
33. Hamrock, B.J.; and Anderson, W.J.: Rolling Element Bearings. NASA RP-1105, 1983.
34. Zaretsky, E.V.; and Anderson, W.J.: Effect of Materials - General Background. Interdisciplinary Approach to the Lubrication of Concentrated Contacts, P.M. Ku, ed., NASA SP-237, 1970, pp. 379-408.
35. Nahm, A.H.: Impact of NASA-Sponsored Research on Aircraft Turbine Engine Bearing Specifications. Advanced Power Transmission Technology, G.K. Fischer, ed., NASA CP-2210, AVRADCOM TR 82-C-16, 1983, pp. 173-184.
36. Bamberger, E.N.; and Kroeger, D.J.: Rolling Element Fatigue Life of a Carburized Modified M50 Bearing Steel. NASA CR-168295, 1984.
37. Bamberger, E.N.; and Nahn, A.H.: Improved Fracture Toughness Corrosion - Resistant Bearing Material. NASA CR-174990, 1986.
38. Zaretsky, E.V.; Schuller, F.T.; and Coe, H.H.: Lubrication and Performance of High-Speed Rolling-Element Bearings. Lubr. Eng., vol. 41, no. 12, Dec. 1985, pp. 725-732.
39. Schuller, F.T.: Lubrication of 35-mm - bore Ball Bearings of Several Designs to 2.5 Million DN. Advanced Power Transmission Technology, G.K. Fischer, ed., NASA CP-2210, AVRADCOM TR 82-C-16, 1983, pp. 221-238.
40. Morrison, F.R.; Gassel, S.S.; and Borenkerk, R.L.: Development of Small Bore, High-Speed Tapered Roller Bearing. NASA CR-165375, 1981.
41. Parker, R.J.: Large Bore Tapered Roller Bearing Performance and Endurance to 2.4 Million DN. Advanced Power Transmission Technology, G.K. Fischer, ed., NASA CP-2210, AVRADCOM TR 82-C-16, 1983, pp. 253-270.
42. Loewenthal, S.H.; Rohn, D.A.; and Anderson, N.E.: Advances in Traction Drive Technology. SAE Paper 831304, 1983.
43. Haddon, G.B., et al.: User's Manual for Computer Program SHABERTH. (SKF-AT81D040, SKF Technology Services; NASA Contract NAS3-22690.) NASA CR-165365, 1981.
44. Dyba, G.J.; and Kleckner, R.J.: User's Manual for SKF Computer Program CYBEAN. (SKF-AT81D049-vol-2, SKF Technology Services; NASA Contract NAS3-22690.) NASA CR-165364, 1981.
45. Kleckner, R.J.; Dyba, G.J.; and Ragen, M.A.: User's Manual for SKF Computer Program SPHERBEAN. (SKF-AT81D007, SKF Technology Services; NASA Contract NAS3-22807.) NASA CR-167859, 1982.
46. Haden, G.B., et al.: User's Manual for SKF Computer Program PLANETSYS. (SKF-AT81D044, SKF Technology Services; NASA Contract NAS3-22690.) NASA CR-165366, 1981.
47. COSMIC Software Catalog. NASA CR-176274, 1986.
48. Parker, R.J.: Comparison of Predicted and Experimental Thermal Performance of Angular-Contact Ball Bearings. NASA TP-2275, 1984.

49. Coe, H.H.; and Schuller, F.T.: Calculated and Experimental Data for a 118-mm Bore Roller Bearing to 3 Million DN. *J. Lubr. Technol.*, vol. 103, no. 2, Apr. 1981, pp. 274-283.
50. Coe, H.H.: Thermal Analysis of a Planetary Transmission with Spherical Roller Bearings Operating after Complete Loss of Oil. NASA TP-2367, 1984.
51. Anderson, N.E.; and Loewenthal, S.H.: Spur-Gear-System Efficiency at Part and Full Load. NASA TP-1622, AVRADCOM TR 79-46, 1980.
52. Anderson, N.E.; Loewenthal, S.H.; and Black, J.D.: An Analytical Method to Predict Efficiency of Aircraft Gearboxes. NASA TM-83716, USAAVSCOM TR 84-C-8, 1984.
53. Wang, K.L.; and Cheng, H.S.: Thermal Elastohydrodynamic Lubrication of Spur Gears. NASA CR-3241, 1980.
54. Chao, C. H.-C.: A Computer Solution for the Dynamic Load, Lubricant Film Thickness and Surface Temperatures in Spiral Bevel Gears. PhD Dissertation, Northwestern University, 1982.
55. August, R., et al.: Dynamics of Early Planetary Gear Trains. NASA CR-3793, 1984.
56. Boyd, L.S.; and Pike, J.: Multi-Mesh Gear Dynamics Program Evaluation and Enhancements. NASA CR-174747, 1985.
57. Pike, J.A.: Interactive Multiple Spur Gear Mesh Dynamic Load Program. NASA CR-165514, 1982.
58. Shuey, L.W.: An Investigation of the Dynamic Response of Spur Gear Teeth with Moving Loads. M.S. Thesis, Michigan Technological University, 1983.
59. Lin, H.-H.; and Huston, R.L.: Dynamic Loading on Parallel Shaft Gears. (UC-MIE-051586-19, Cincinnati University; NASA Grant NSG-3188.) NASA CR-179473, 1986.
60. Savage, M.; Coy, J.J.; and Townsend, D.P.: Optimal Tooth Numbers for Compact Standard Spur Gear Sets. *J. Mech. Des.*, vol. 104, no. 4, Oct. 1982, pp. 749-758.
61. Savage, M., et al.: Life and Reliability Modeling of Bevel Gear Reductions. ASME Paper 85-DE-7, Mar. 1985.
62. Lewicki, D.G., et al.: Fatigue Life Analysis of a Turboprop Reduction Gearbox. *Journal of Mechanisms, Transmissions, and Automation in Design*, vol. 108, no. 2, June 1986, pp. 255-262.
63. Savage, M.; and Brikmanis, C.K.: System Life and Reliability Modeling for Helicopter Transmissions. NASA CR-3967, 1986.
64. Savage, M.; Caldwell, R.J.; and Lewicki, D.G.: Gear Mesh Compliance Modeling. NASA TM-88843, USAAVSCOM TR 86-C-28, 1986.
65. Lewicki, D.G.: Predicted Effect of Dynamic Load on Pitting Fatigue Life for Low-Contact-Ratio Spur Gears. NASA TP-2610, AVSCOM TR 86-C-21, 1986.
66. Braddock, C.E.; and Battles, R.A.: Design of an Advanced 500 HP Helicopter Transmission. *Advanced Power Transmission Technology*, G.K., Fischer, ed., NASA CP-2210, AVRADCOM TR 82-C-16, 1983, pp. 123-140.
67. Folenta, D.J.: Design Study of Self-Aligning Bearingless Planetary (SABP). (TTC-80-01R, Transmission Technology Co.; NASA Contract NAS3-21604.) NASA CR-159808, 1980.
68. White, G.: 3600 HP Split Torque Helicopter Transmission, NASA CR-174932, 1985.



REQUIREMENT	GOAL	BENEFIT
LIGHTER STRONGER	DRIVE TRAIN SPECIFIC WEIGHT .3 TO .5 LB/HP (CURRENTLY .4 TO .6 LB/HP)	INCREASED RANGE AND PAYLOAD
MORE RELIABLE	5000 HR MTBO (CURRENTLY 500-2000 HRS)	LOWER OPERATING COST AND SAFER OPERATION
QUIETER	70-80 db IN CABIN (CURRENTLY 100-110 db)	GREATER USE FOR COMMERCIAL COMMUTER SERVICE INCREASED PASSENGER AND PILOT COMFORT

CD-84-15112

Figure 1. - Required technological advancements for helicopter transmissions in the 1990's.

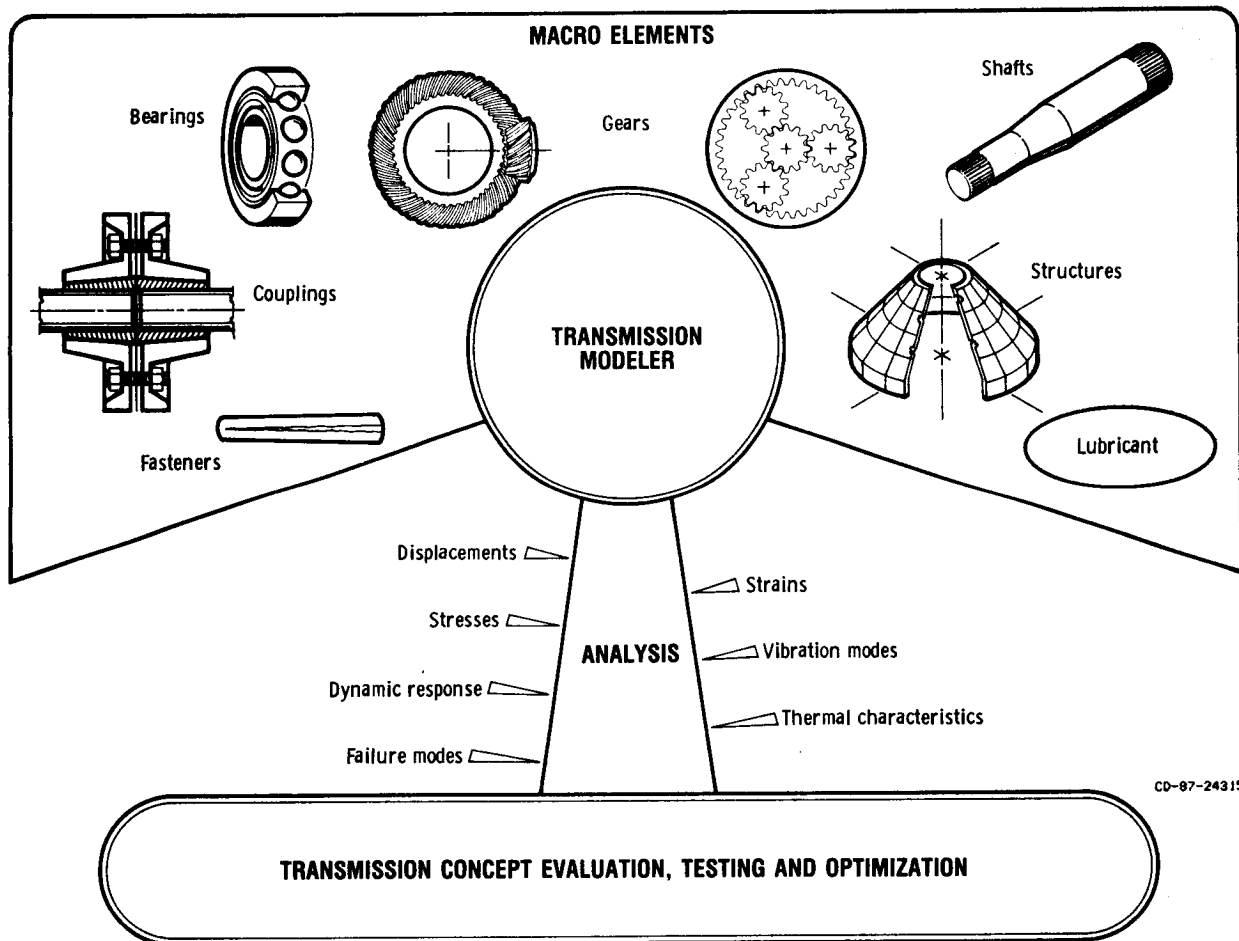

Figure 2. - Concept for a comprehensive computer program library for modelling and analysis of transmissions.

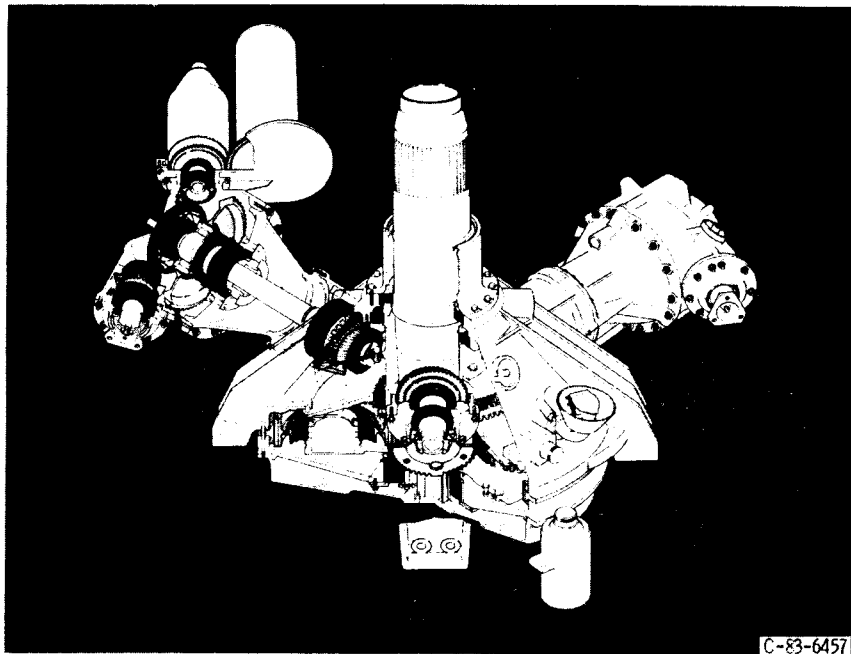

Figure 3. - Isometric section view of UH-60A helicopter transmission.

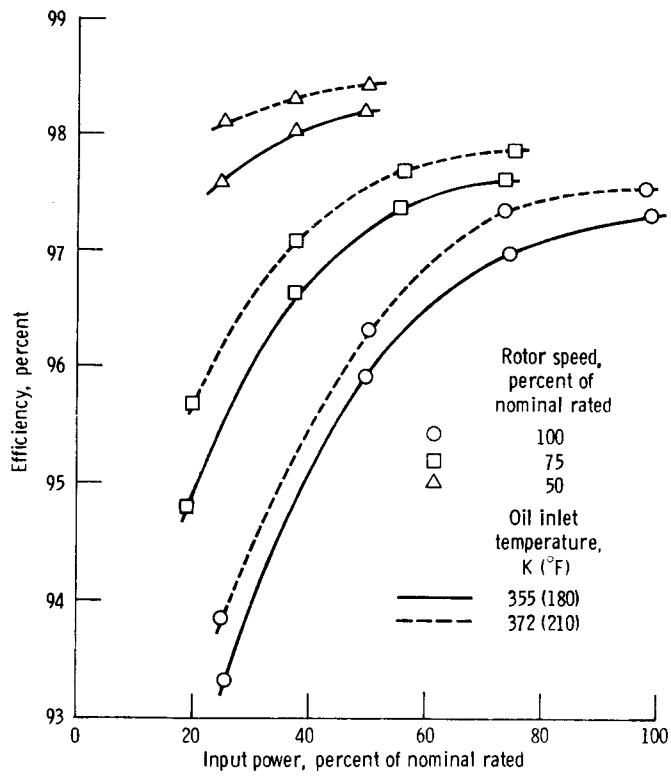

Figure 4. - Measured mechanical efficiency of UH-60A helicopter transmission plotted against input power, as a function of rotor speed and oil temperature.

ORIGINAL PAGE IS  
OF POOR QUALITY

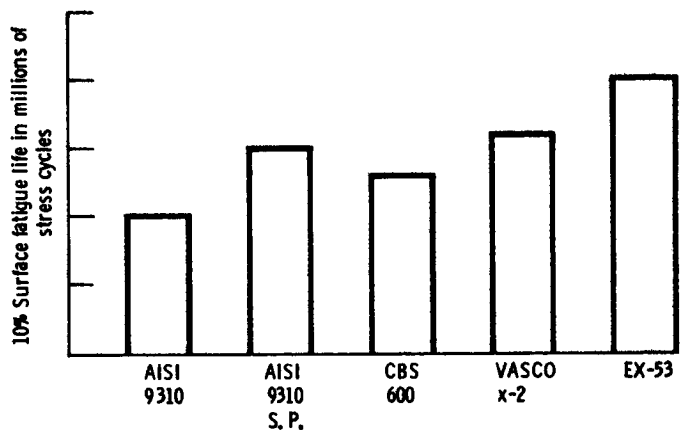

Figure 5. - Fatigue life for four gear materials compared to baseline AISI 9310 material. (S. P. - Shot Peened). Tests conducted on NASA Spur Gear Rig.

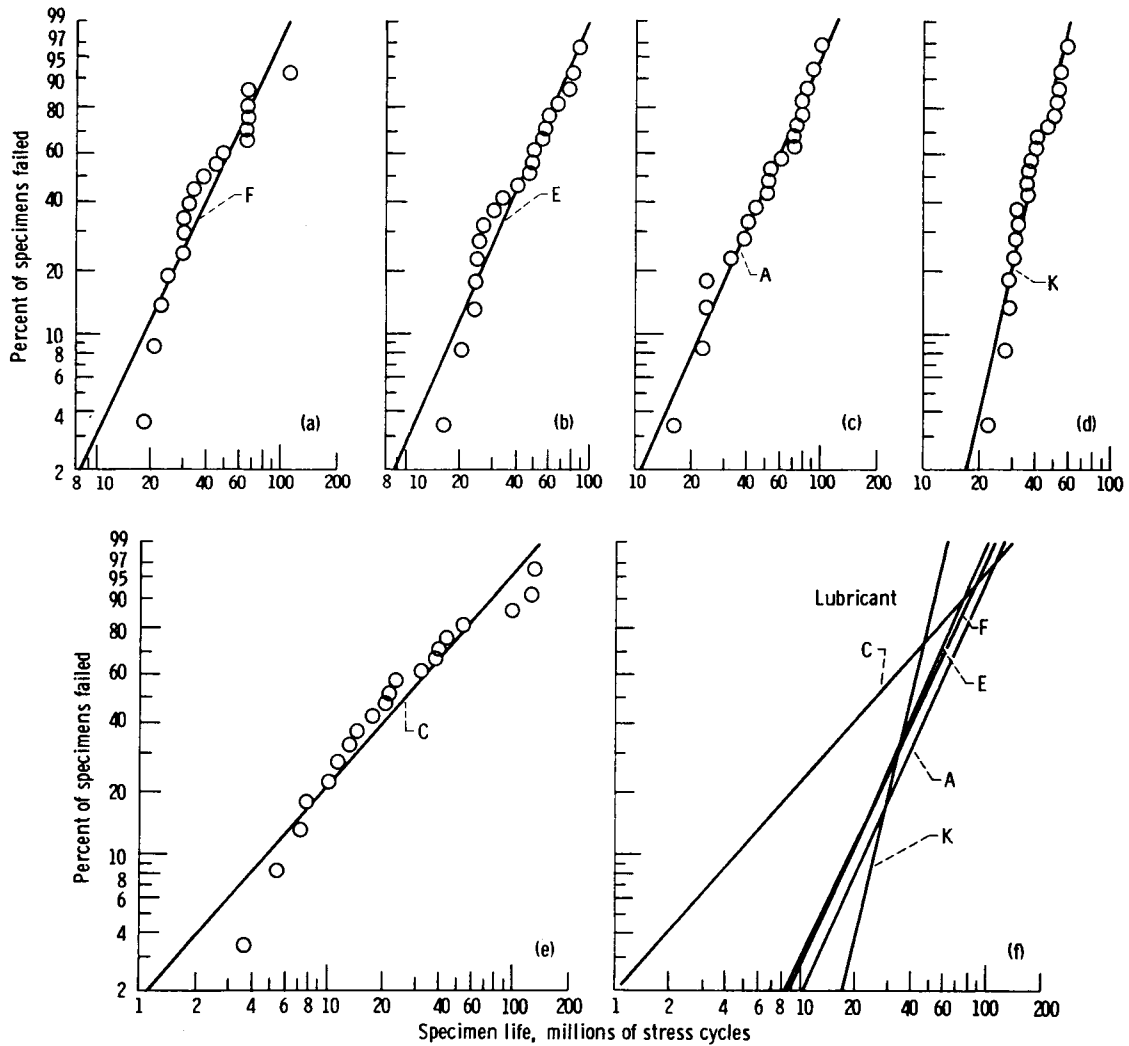

Figure 6. - Surface pitting fatigue life as affected by type of lubricant. Tests conducted on NASA Spur Gear Rig. Gear material - CVM AISI 9310, speed - 10 000 rpm, temperature - 350 K (170 °F), maximum Hertz stress - 1,7 MPa (248 000 psi). Lubricant types: A - Mobil ATF 220, C - Aeroshell 500, E - Syn Tech NS677, F - Mobil RL714, K - Aeroshell 555.

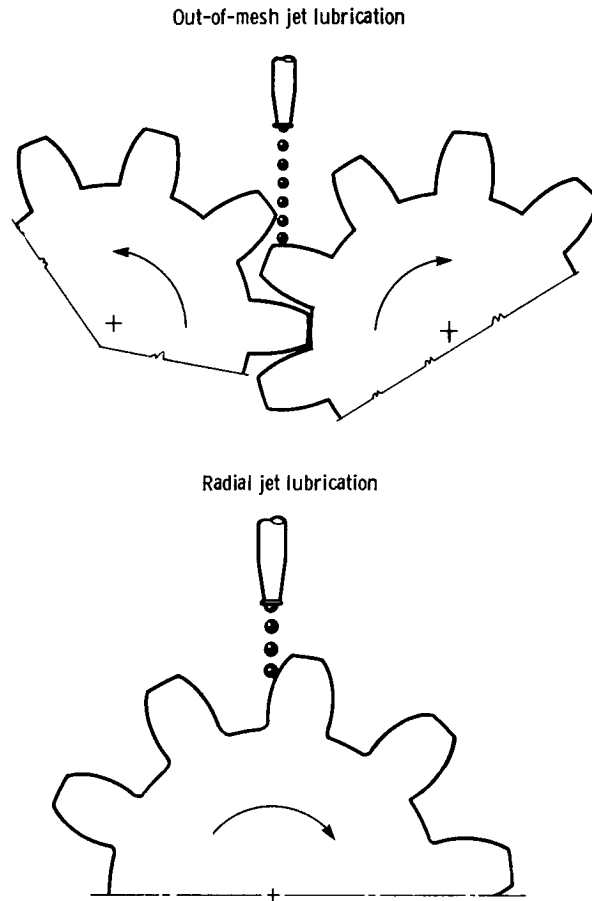

Figure 7. - Two ways of aiming the oil jets to lubricate gear teeth. Radially aimed jet penetrates further to better cool gear tooth. Out-of-mesh aimed jet has less power loss compared to into-mesh directed flow.

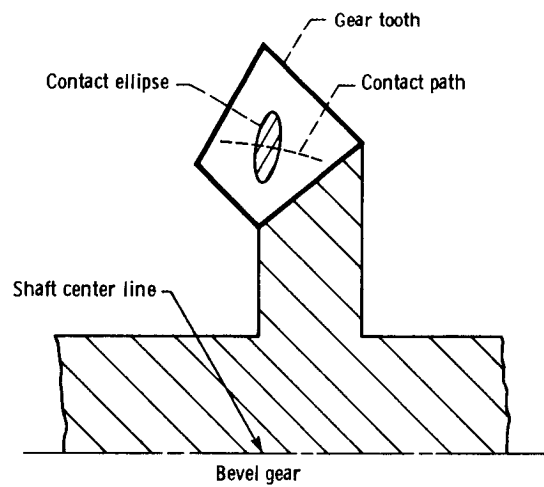

Figure 8. - Contact ellipse moves across the face of the gear tooth as the gear meshes with its mating gear (not shown).

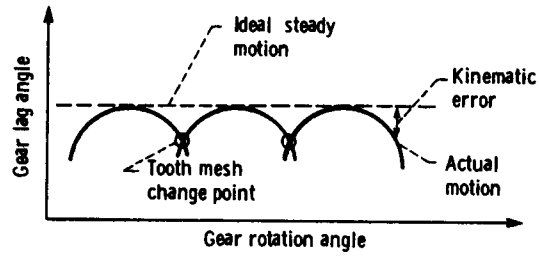

Figure 9. - Kinematic error function for the mesh of several gear teeth.

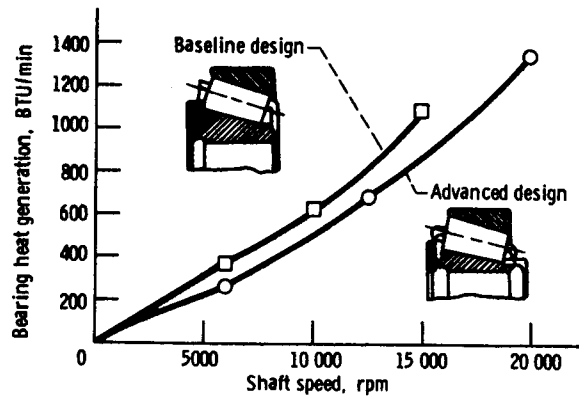
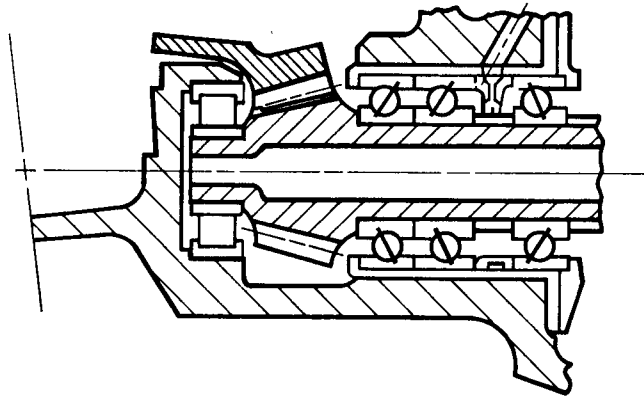
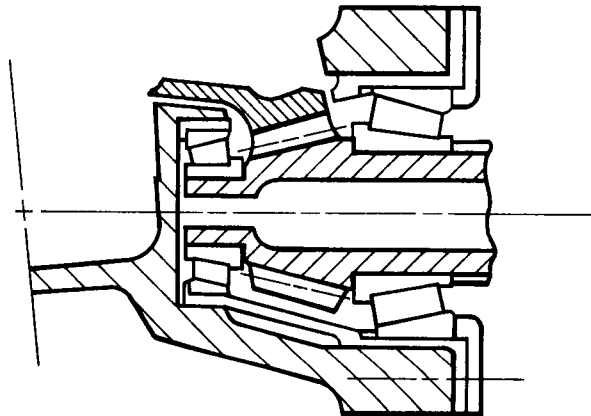

Figure 10. - Advanced design for tapered roller bearings provides cooler operation at high speed.



(a) Ball and roller bearings.



(b) Tapered-roller bearings.

Figure 11. - Tapered roller bearings replace ball and cylindrical roller bearings on input shaft for helicopter transmission.

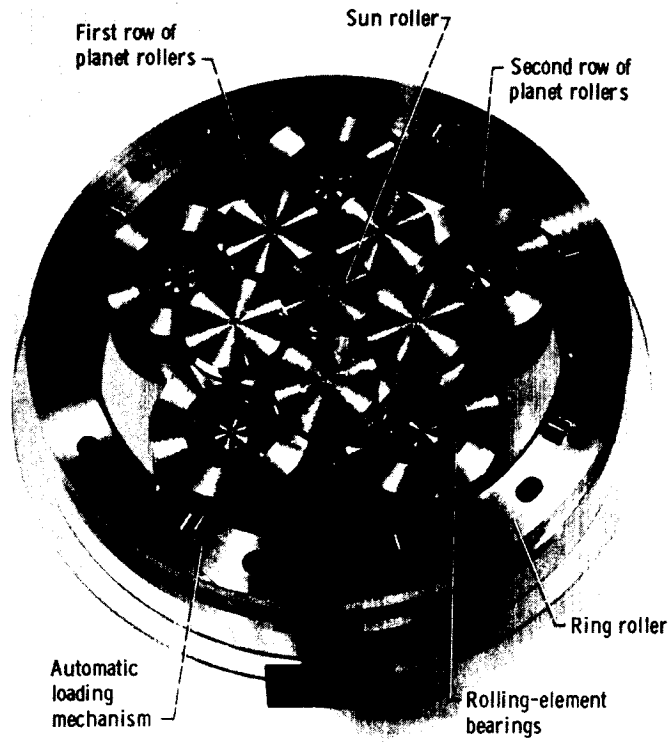

(a) Experimental traction drive transmission.

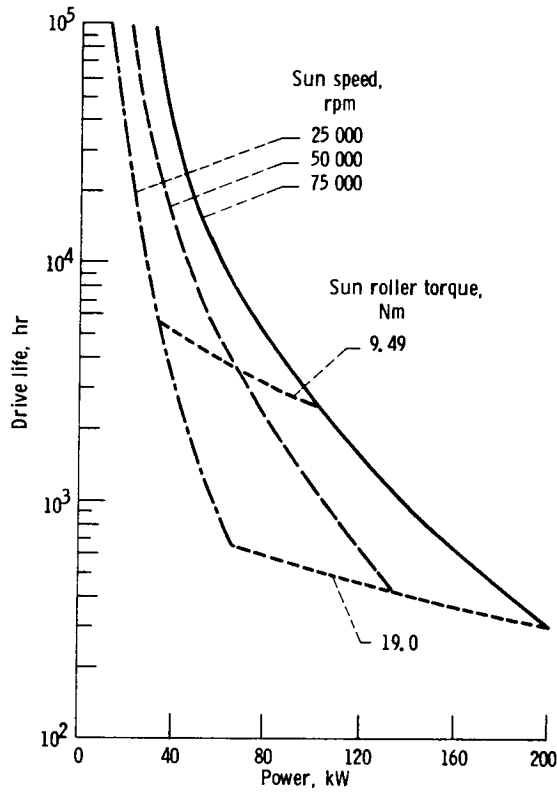

ORIGINAL PAGE IS  
OF POOR QUALITY

(b) Analytical results for drive life as a function of power, torque, and speed.

Figure 12. - Results of traction drive research.



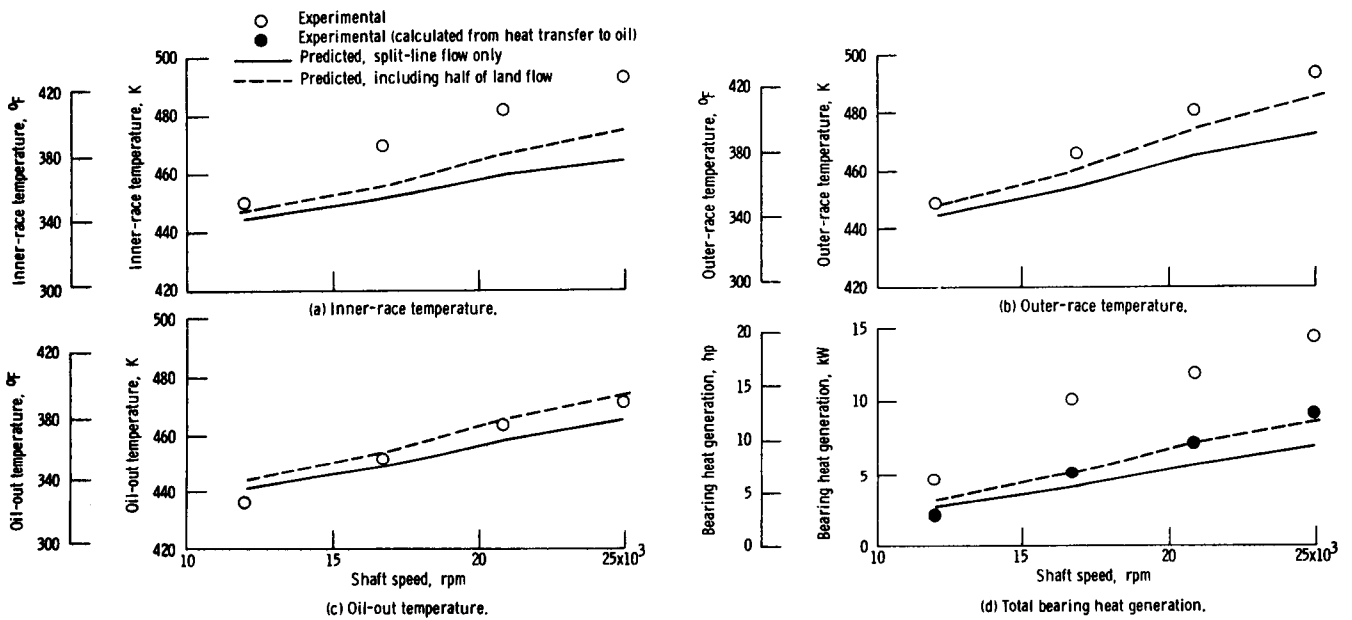
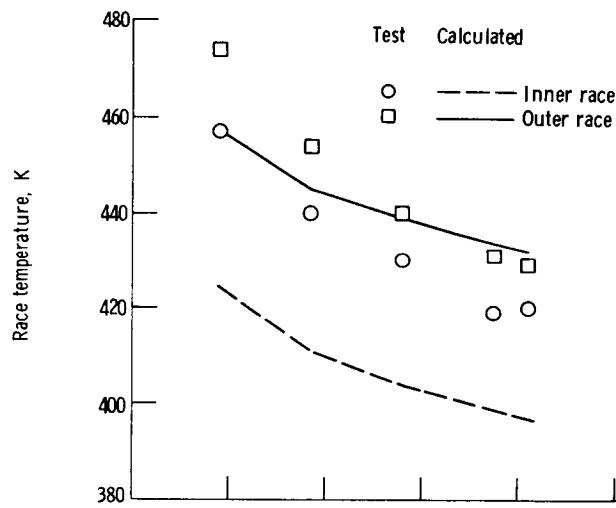
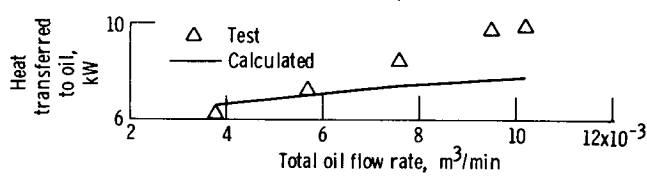

Figure 13. - Predicted and experimental thermal performance of 120 mm bore ball bearing as function of shaft speed. Thrust load, 22 240 N (5000 lb); oil-in temperature, 427 K (310 °F); total lubricant flow rate, 4740 cm<sup>3</sup>/min (1.253 gpm).



(a) Race temperatures.



(b) Heat transferred to lubricating oil.

Figure 14. - Comparison of calculated and experimental bearing data using a cold diametral clearance of 0.09 mm in the computer program. Shaft speed, 20 000 rpm; radial load, 8900 N (2000 lb); lubricant volume, 2 percent.

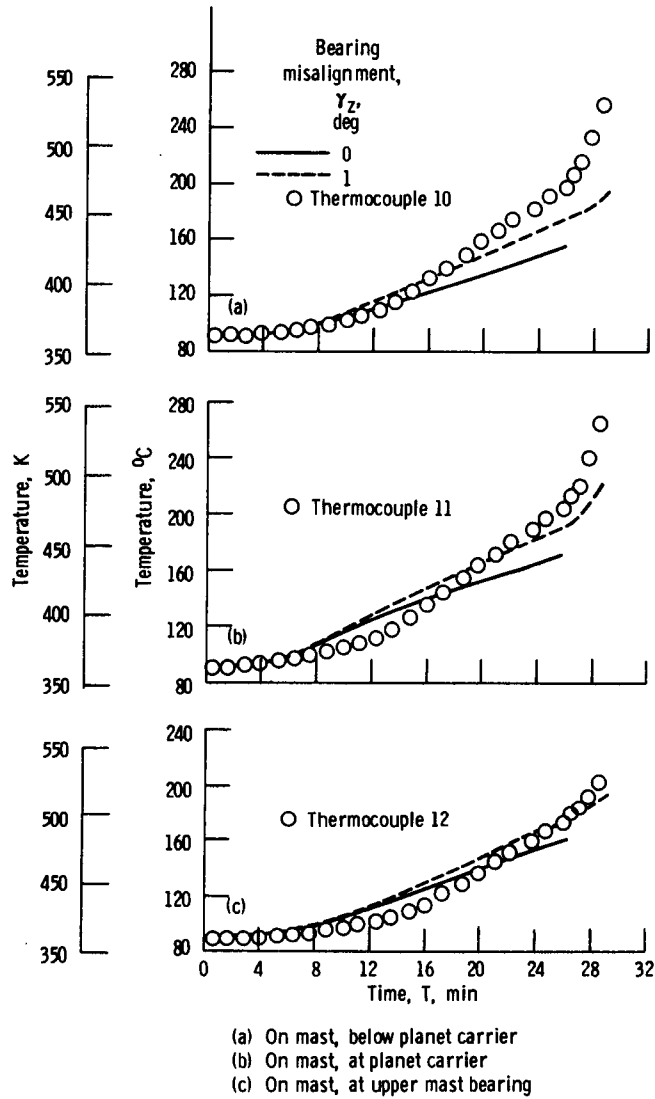

Figure 15. - Computer simulation of loss of lubricant in the OH-58 transmission. Predicted transient temperatures compared to experimental data, output shaft area. Drain plug removed at  $T = 0$ ; oil pressure to zero at  $t = 1.5$  minutes.

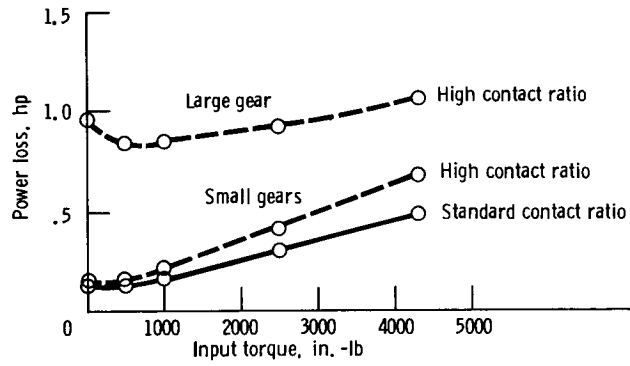

Figure 16. - Power loss predictions as a function of speed for gears, showing effect of size and contact ratio.

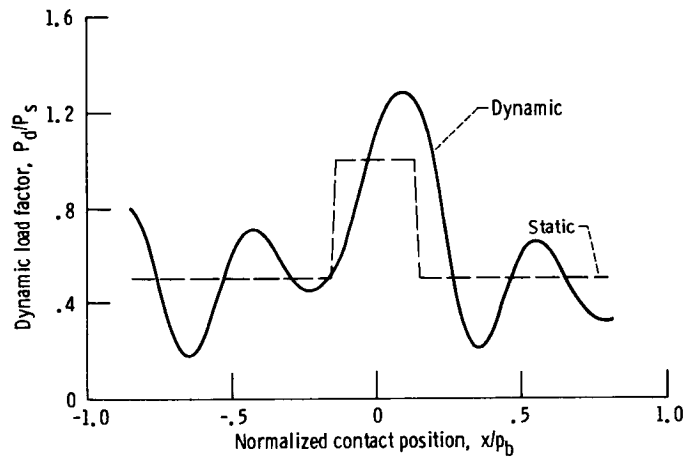

Figure 17. - Gear tooth dynamic load factor compared to static load as a function of position of the contact point.

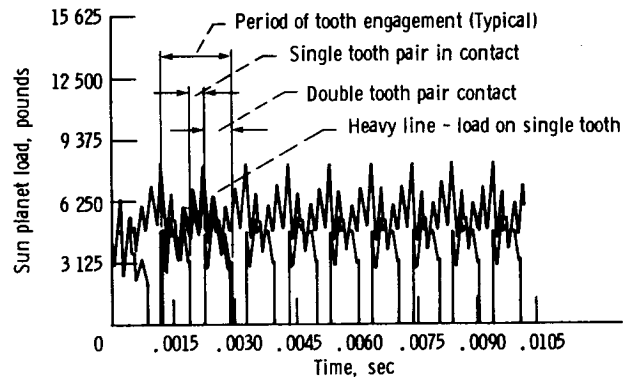
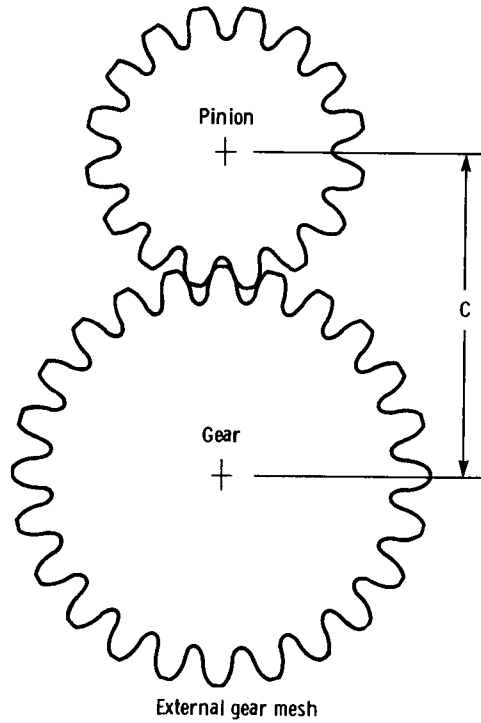
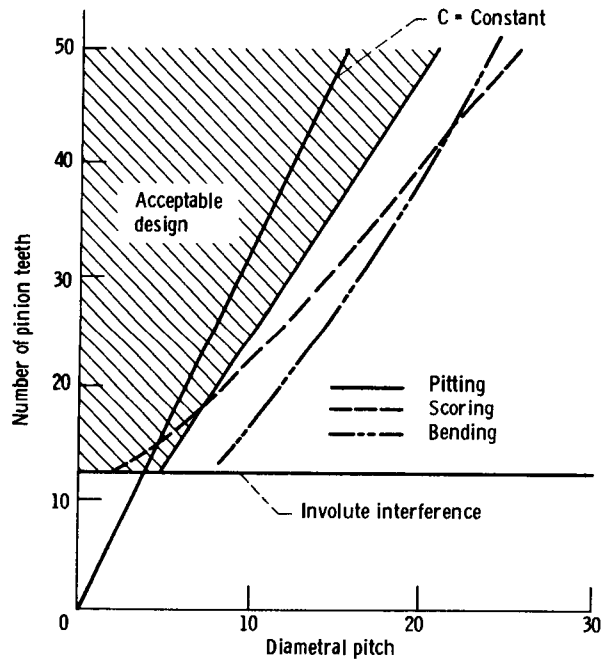

Figure 18. - Sun-planet dynamic load for 9 teeth engagements on 3000 hp helicopter transmission. Speed - 1200 rpm, Torque - 4500 in. -lb.



(a) Minimization of center distance reduces size and weight.



(b) In design space of number of pinion teeth versus diametral pitch, there is an allowable region of design. Line labeled "C = Constant" is locus of constant center distance designs. Minimum weight designs lie on the right hand edge of the shaded region.

Figure 19. - Results of weight minimization study for spur gears.

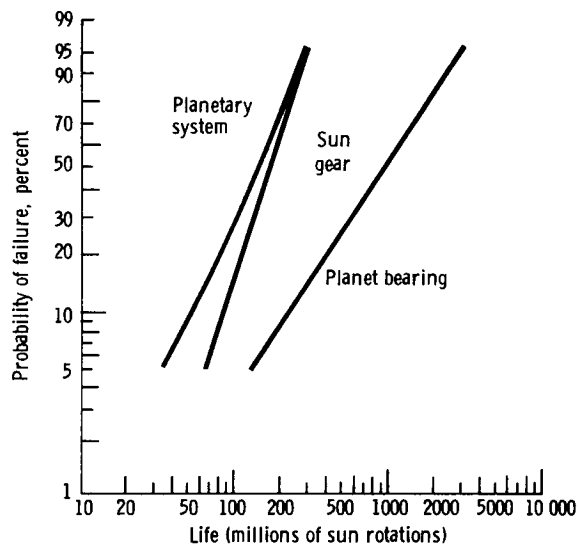

Figure 20. - Calculated Weibull distributions for sun gear, planet bearing, and complete planetary assembly of sun, bearings, planets, and gear.

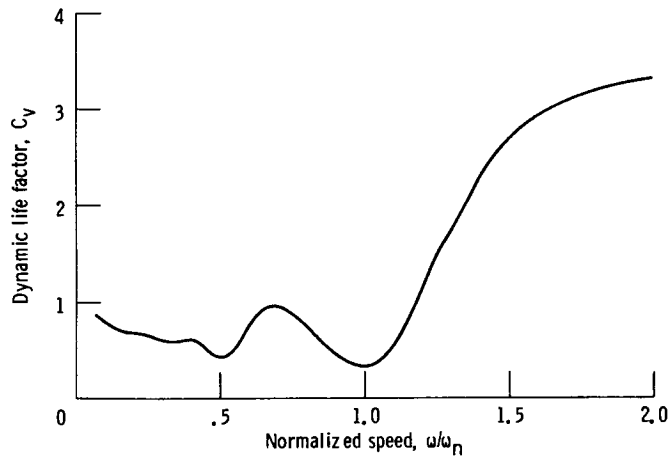

Figure 21. - Gear mesh life plotted against speed.

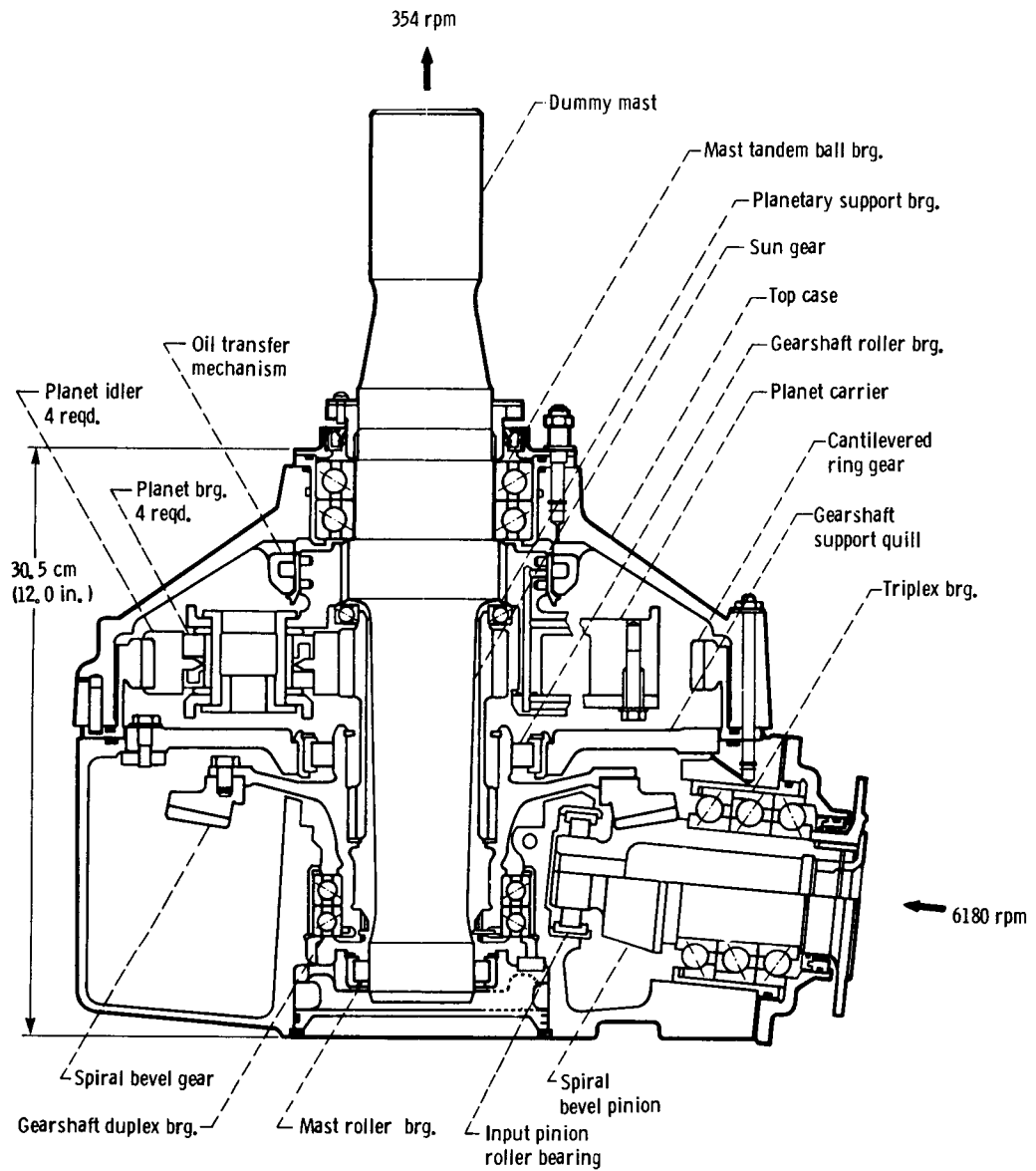
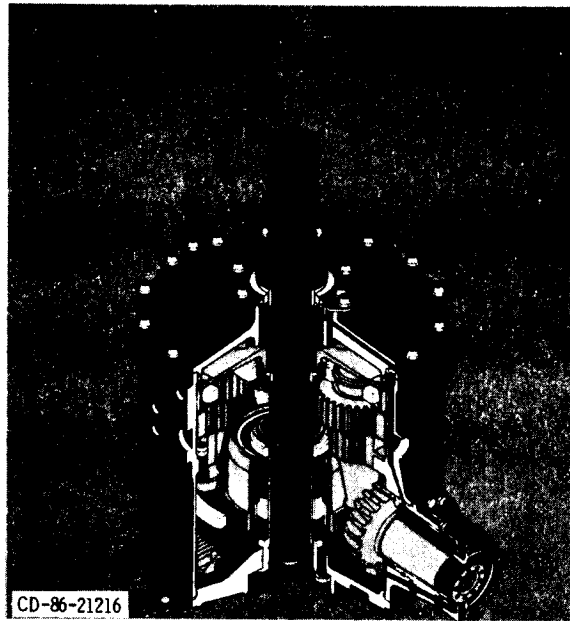
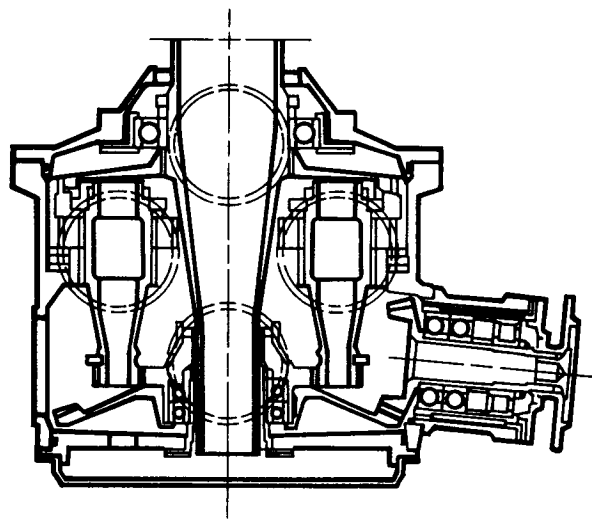

Figure 22. - Advanced 500 hp transmission.

ORIGINAL PAGE IS  
OF POOR QUALITY



(a) Isometric view.



(b) Cross section view.

Figure 23. - Self-aligning bearingless planetary transmission.



ORIGINAL PAGE IS  
OF HIGH QUALITY

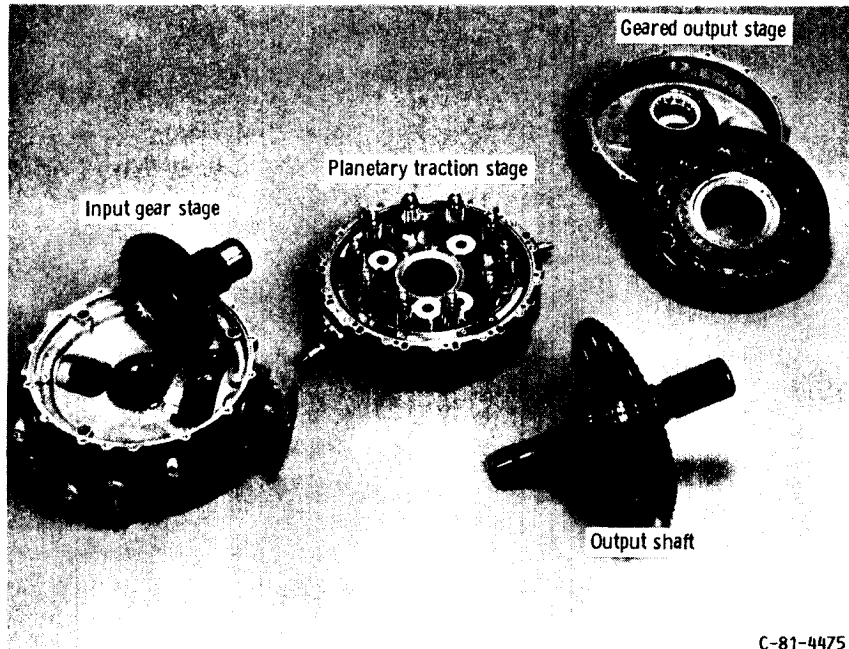

C-81-4475

Figure 24. - Traction hybrid transmission.

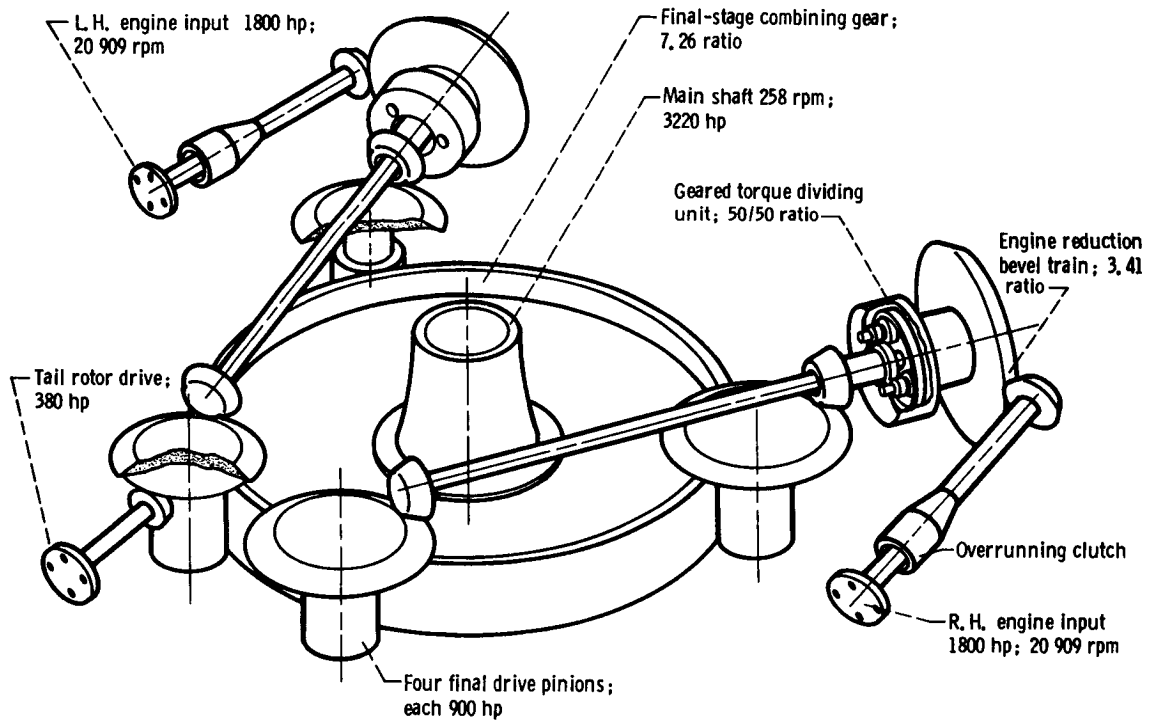

Figure 25. - Split-torque transmission generally configured for UH-60 Blackhawk helicopter.