

N88-16652

SYSTEM ANALYSIS IN ROTORCRAFT DESIGN THE PAST DECADE

Thomas L. Galloway

National Aeronautics and Space Administration
Ames Research Center

Abstract

Rapid advances in the technology of electronic digital computers and the need for an integrated synthesis approach in developing future rotorcraft programs has led to increased emphasis on system analysis techniques in rotorcraft design. System analysis may be described as "putting it all together." The task in systems analysis is to deal with complex, interdependent, and conflicting requirements in a structured manner so rational and objective decisions can be made. Whether the results are wisdom or rubbish depends upon the validity and sometimes more importantly, the consistency of the inputs, the correctness of the analysis, and a sensible choice of measures of effectiveness to draw conclusions. In rotorcraft design this means combining design requirements, technology assessment, sensitivity analysis and performance benefits to evaluate system effectiveness. This paper reviews techniques currently in use by NASA and Army organizations in developing research programs and vehicle specifications for rotorcraft. These procedures span simple graphical approaches to comprehensive analysis on large mainframe computers. Examples of recent applications to military and civil missions are highlighted.

Introduction

System analysis is not an invention of the past decade, but it is receiving more widespread use in all types of design problems due to the increased availability of new desktop computing power. Reference 1 is an early example of the system analysis technique applied to VTOL missions which dates back to the 1950's. The task of system analysis is still the same. That is dealing with complex and interdependent problems in such a manner so that decisions may be made rationally and objectively. Early definitions of system analysis emphasized mathematical means and efficiency. This was largely descriptive of the methodologies that were introduced into the U.S. Department of Defense decision making by the RAND Corporation in the early 1960's. Today, the field has developed to encompass non-mathematical means of analysis and a greater concern with effectiveness, rather than mere efficiency. The systems approach is a process which involves: (a) a systematic examination and comparison of those alternative actions which are related to the accomplishment of desired objectives; (b) comparison of alternatives on the basis of the costs and benefits associated with each alternative; and (c)

explicit consideration of risk.

The rapid advances in desktop computing power during the past decade has provided the tools necessary to encourage widespread use of the system analysis approach. Figure 1 illustrates the change in computer availability and processing capability over the past decade. Ten years ago, when the 8-bit personal computer was introduced in quantity, it provided access to a more user friendly tool than the mainframes but with limited computing power. Advances in operating systems and semi-conductor technology narrowed the gap in the user-friendly concepts of the mini-computer and the power of the mainframe. The continuing advances in 32-bit chip technology has created the current era of the modern graphics workstation with highly useful desktop computing power. Continued cost reductions in these workstations has also led to their increased utilization. Moreover, advancements in networking and database management provide the capability for multiple users to share information on complex projects as well as have access to powerful super-computers. In the future, the application of artificial intelligence technology through expert systems will continue to enhance the application of the system analysis process in aerospace design problems.

System Elements

All systems begin as a gleam in the eye of someone and undergo many different phases of analysis, testing, and development before being deployed, made operational, or marketed. This is true for weapon systems, transportation systems, or new products. The role of system analysis is to develop a systematic procedure for evaluating design options against measures of effectiveness to achieve the objectives. The three basic elements of system analysis have not changed over the years. They are: (a) establishing the objectives; (b) selecting the measures of effectiveness; and (c) developing a model to use in the analysis. These elements can be considered to form a pyramid as shown in Figure 2 with the foundation being the model of the system.

In recent years there have been several software programs developed for desktop personal computers that can provide assistance in developing project outlines and plans which can contribute to establishing objectives and measures of effectiveness. This paper will not address those tools. The focus of this paper is on the modeling concepts that are used in developing rotorcraft concepts and evaluating technological advances. With the increase in desktop computing power, the engineer can now explore many design options early in the design process. This does not mean that the engineer is being replaced by the computer but that his capability is being enhanced through more powerful tools which frees him to be more creative. Although the subject here is rotorcraft, the techniques are applied through out the aerospace industry.

System Models

For purpose of discussion the models used in the design analysis process will be divided into two major categories. One will deal with models used in the integrated analysis of a design. The other, addresses models used by specialists for analysis of a specific technical area. The models in both categories play key roles in analyzing the design options and evaluating the selected measures of effectiveness. Various levels of sophistication can be incorporated into the models that are part of the system or design analysis process. Many of the models originated 15 - 20 years ago but their utility has been enhanced with pre- and post- processors that take advantage of the more user-friendly computing environment of today. Some models are computerized versions of simple graphical approaches while others represent capability that resulted directly from the development of the modern graphical workstation.

The initial discussion will deal with models that are in the category of integration. These models are constructed so that the various technical disciplines are analyzed in such a manner so the interaction among disciplines results in a more balanced design. Figure 3 depicts the flow of information through a typical integration or synthesis model. The synthesis code estimates the vehicle performance based on input mission requirements and constraints for a given level of technology assumptions. Vehicle weight, power, and geometric characteristics are computed along with mission performance parameters. These analytical models and associated input data are generally calibrated using either experimental test results or predicted results from a more specialized analysis.

These models are useful for performing tradeoff studies, sensitivity analysis, concept comparisons and technology evaluations. They are used through out the rotorcraft and fixed wing industry. Some examples of those used by the government are listed in figure 3. References 2 and 3 describe the HESCOMP and VASCOMP models in more detail. These two models, a jointly developed Army and NASA tilt rotor model, and a Army helicopter model provided the tools necessary to perform the J VX Joint Technology Assessment study of 1982. In the initial two months of study 12,000 evaluations were performed in assessing two helicopter concepts, a tilt rotor, and a lift-fan operating over 19 different missions. In the final three months of study, 5000 evaluations were performed on the tilt rotor investigating alternate engines, rotors, wings and mission capability. These type of models coupled with the advances in computer utility are the only way the 100-125 evaluations per day could be achieved for the J VX study in that short amount of time. Being able to perform such a detailed assessment in only five months, meant a timely program, with definitive specifications, was developed to meet the services window of opportunity.

Most of these models can be run efficiently on the modern 32-bit workstations. On the other hand, using the powerful spreadsheets that have appeared on the market in recent years also provides an effective means to use simplified versions of synthesis models in the early stages of concept evaluation.

The models under the category of specialization are broken into two areas. One is classified here as configuration development, the other as specialized analysis. Figure 4 gives some examples of models in each area. The models listed under configuration development are mainly commercially available products that allow drafting type of functions to be accomplished in a very efficient and rapid manner. The modern graphics workstation is very effective in providing a user-friendly environment for these configuration development models.

The specialized analysis area refers to models that have been developed to perform detailed technical analysis of a specific discipline. As listed in figure 4 these cover the disciplines of structure and loads, aeromechanics, rotor design, and flow-field analysis. The computing power that is now available in workstations allow many of these models to be used interactively early in the design process.

There are some very natural links that can be made between the models described in the previous paragraphs. Some of these links can be automated while others still require the engineer in the loop. Figure 5 depicts the possible links. Under the specialization category there is a natural link for flow of geometric information from the configuration development model to the specialized models. The configuration tools can generate finite element grid type of input definition which is required by specialized models such as NASTRAN and VSAERO. There can be a two way flow of information between the synthesis model and the models in the specialization category. The synthesis model may contain a post-processor that can create a paneling of the resulting geometry to pass to both the configuration development area and the specialized analysis area. This eliminates considerable time in preparing the details usually required for the more complex models. Refined geometric dimensions will flow to the synthesis model from the configuration development model after the volume requirements for the various components have been packaged and the resulting vehicle envelope determined. As mentioned previously, information from the specialized analysis area can be used to calibrate the simplified techniques used in the synthesis model and also provide guidance in establishing the achievable technology levels.

Reference 4 presents the results of a study which utilized this multiple model approach to investigate the feasibility of high-speed tilting-prop-rotor aircraft. The aeromechanics calculations were performed using the Comprehensive Analytical

Model of Rotorcraft Aerodynamics and Dynamics (CAMRAD) of reference 5, a new wing airfoil was designed by a two-dimensional transonic, viscous-flow model (reference 6), the configuration definition utilized the ANVIL 4000 drafting package, and the vehicle synthesis was performed by the Army/NASA tilt rotor code. Figure 6 and 7 show three-view general arrangements of the resulting high-speed, civil transport and the high-speed, air-combat fighter designs. The civil design carries 46 passengers 600 nautical miles at 375 knots. The air-combat fighter is a single pilot design having a 200 nautical mile mission radius and a 400 knot speed capability.

Expert Systems

Although great strides have been made in the productivity and quality of the design process using the system analysis approach there still exists techniques to enhance the process in the future. Knowledge-based expert systems are being considered by many researchers in the aerospace industry to assist in the design procedure. Reference 7 provides some excellent background on how these systems can be used in aircraft conceptual design. Reference 8 describes a second generation expert system, that is currently under development, which will be used in the design of hypervelocity vehicles. The current development is structured around modules that reasons how to solve a design and analysis problem from the knowledge it has on relevant computerized models. It then manages the sequence it has drawn up to execute the models and controls the data input-output flow until the problem is solved. This "Expert Assistant" offers the potential for aiding the design process in a way that is similar to that of numerical optimization, except that it would address discrete, discontinuous, abstract, or any other non optimized aspect of vehicle design and integration. Other unique capabilities such as automatic discovery and learning in design may also be achievable. This could be developed into a tool that would allow the training of people in the system analysis process and also provide expanded analysis capability for junior-level engineers.

Concluding Remarks

The system analysis process has been significantly enhanced in the past decade because of the rapid advances in computer technology. The performance and relatively low cost of the modern workstation let small companies, small groups within an organization, and individual designers have computing power they can control right in their offices. The development of user-friendly interfaces allows existing models to be networked in an efficient manner. Engineering tasks that would take months to perform in the past can be accomplished in weeks. This increase in productivity can also allow the performance of broader trade studies to enhance the quality of the output. In the future the incorporation of expert systems will provide a "designer

assistant" that will increase the usefulness of junior engineers, make analysts of designers and vice versa, and offer the potential for further reductions in product development time and cost while increasing product quality.

References

1. Schnebly, F. David, "The Systems Approach to the Selection of VTOL Aircraft Design Specifications," Presented at the National Naval Aviation Meeting, August 5-10, 1957, San Diego, CA.
2. Davis, S.J., Rosenstein, H., Stanzione, K.A. and Wisniewski, J.S., "User's Manual for HESCOMP The Helicopter Sizing and Performance Computer Program," Boeing Vertol Company, Second Revision October 1979.
3. Schoen, A.H., Rosenstein, H., Stanzione, K.A. and Wisniewski, J.S., "User's Manual for VASCOMP II The V/STOL Aircraft Sizing and Performance Computer Program," Boeing Vertol Company, Third Revision, May 1980.
4. Johnson, Wayne, Benton, Lau H. and Bowles, Jeffery V., "Calculated Performance, Stability, and Maneuverability of High-Speed Tilting-Prop-Rotor Aircraft," Presented at the Twelfth European Rotorcraft Forum, September 22-25, 1986, Garmisch-Partenkirchen.
5. Johnson, Wayne, "A Comprehensive Analytical Model of Rotorcraft Aerodynamics and Dynamics," NASA TM 81182, 81183, and 81184, 1980.
6. Hicks, Raymond M., "An Assessment of a Modified Potential Flow Code for Calculating the Effect of Small Geometric Change on the Pressure and Forces of Supercritical Airfoils," NASA TM 84227, 1982.
7. Kidwell, George and Eskey, Megan, "Expert Systems and Their Use in Augmenting Design Optimization," AIAA Paper 85-3095, Colorado Springs, CO., October 1985.
8. Mitchell, Alan R., "Market Supremacy Through Engineering Automation," Aerospace America, Vol. 25, No. 1, January 1987.

COMPUTER TECHNOLOGY

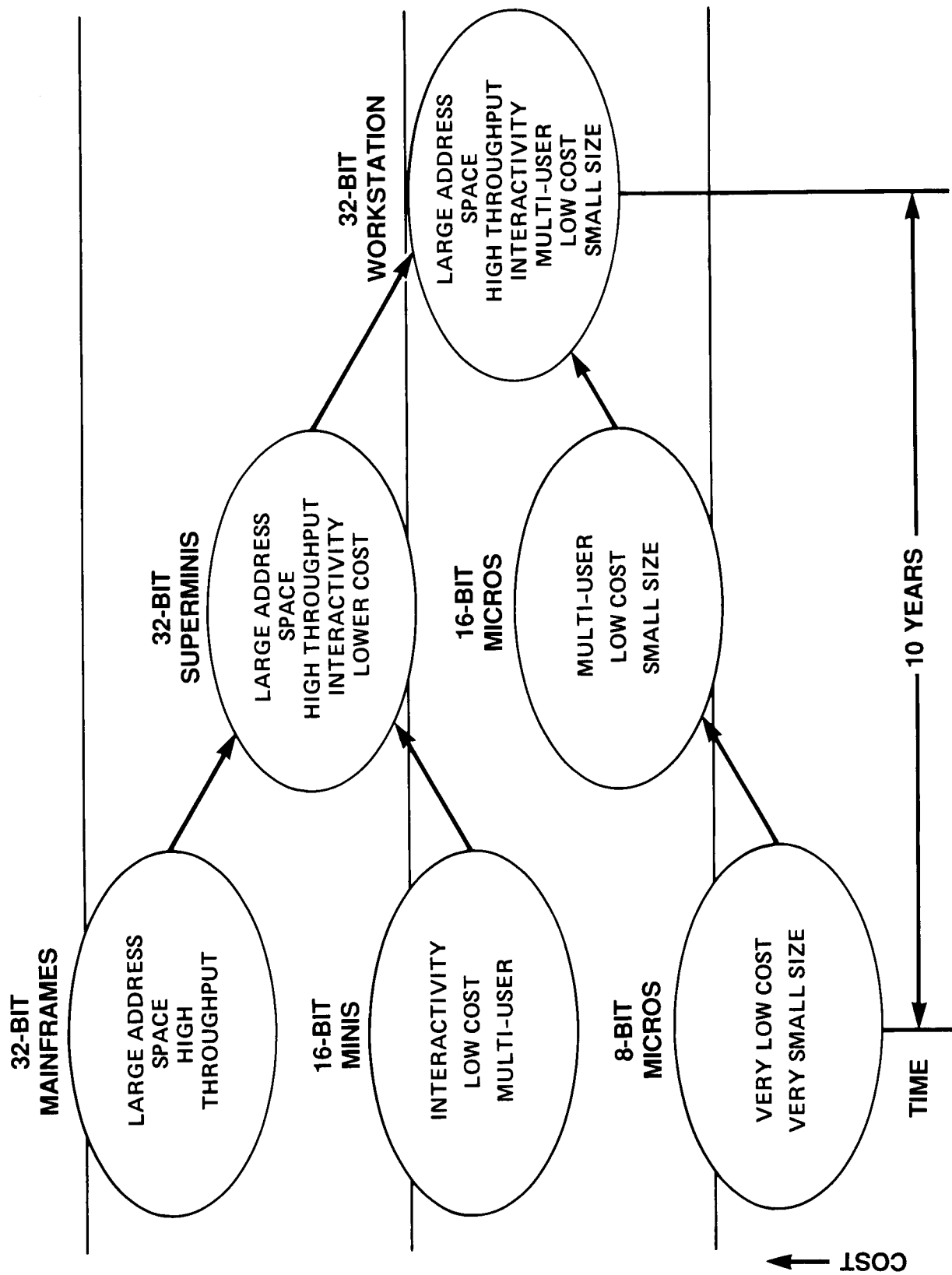

Figure 1.

MAJOR ELEMENTS OF SYSTEMS ANALYSIS

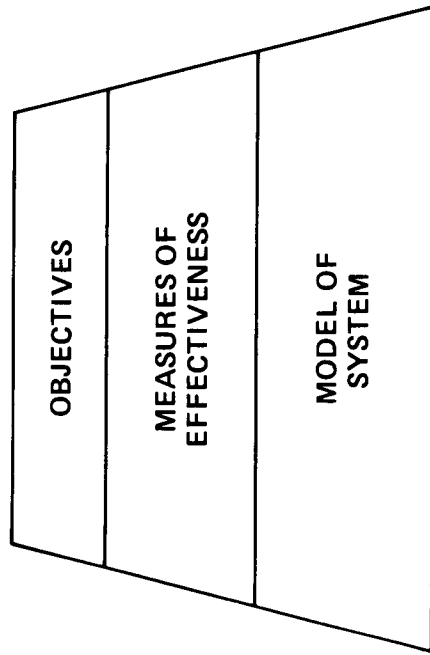

Figure 2.

INTEGRATION MODELS

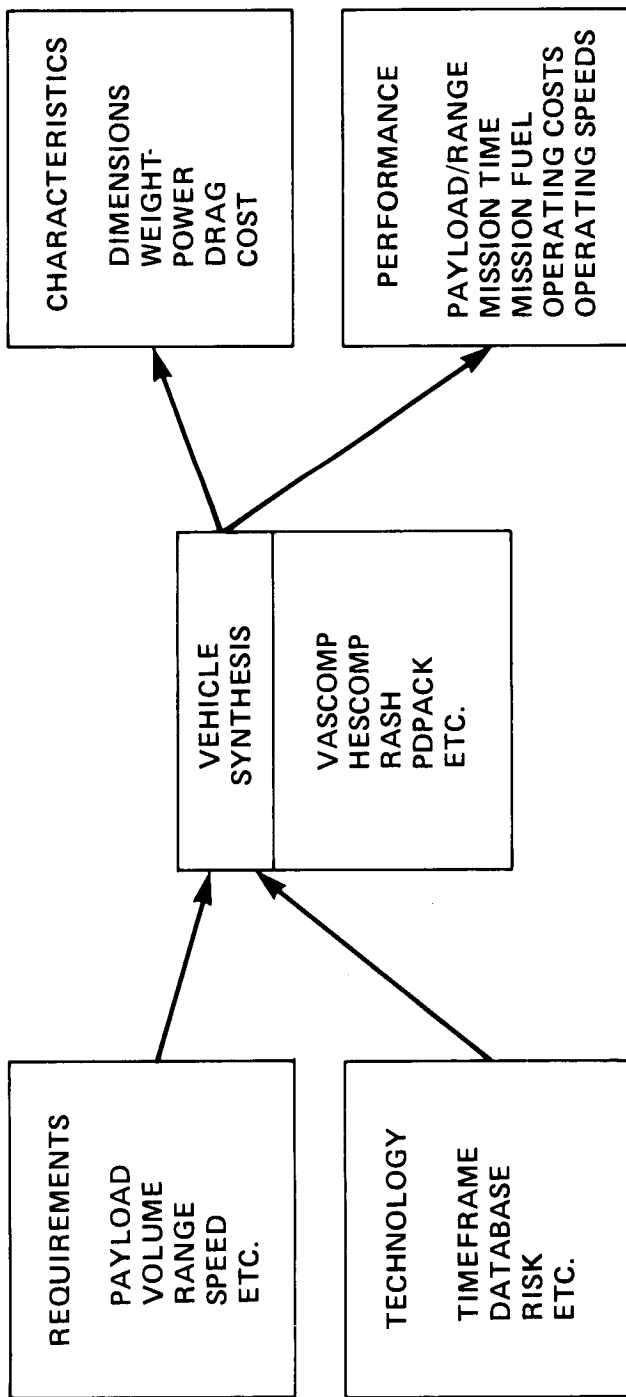

Figure 3.

SPECIALIZATION MODELS

CONFIGURATION DEVELOPMENT	SPECIALIZED ANALYSIS
CADAM CATIA ANVIL CDS ETC.	NASTRAN CAMRAD ROT22 VSAERO ETC.

Figure 4.

ROTORCRAFT SYSTEM ANALYSIS

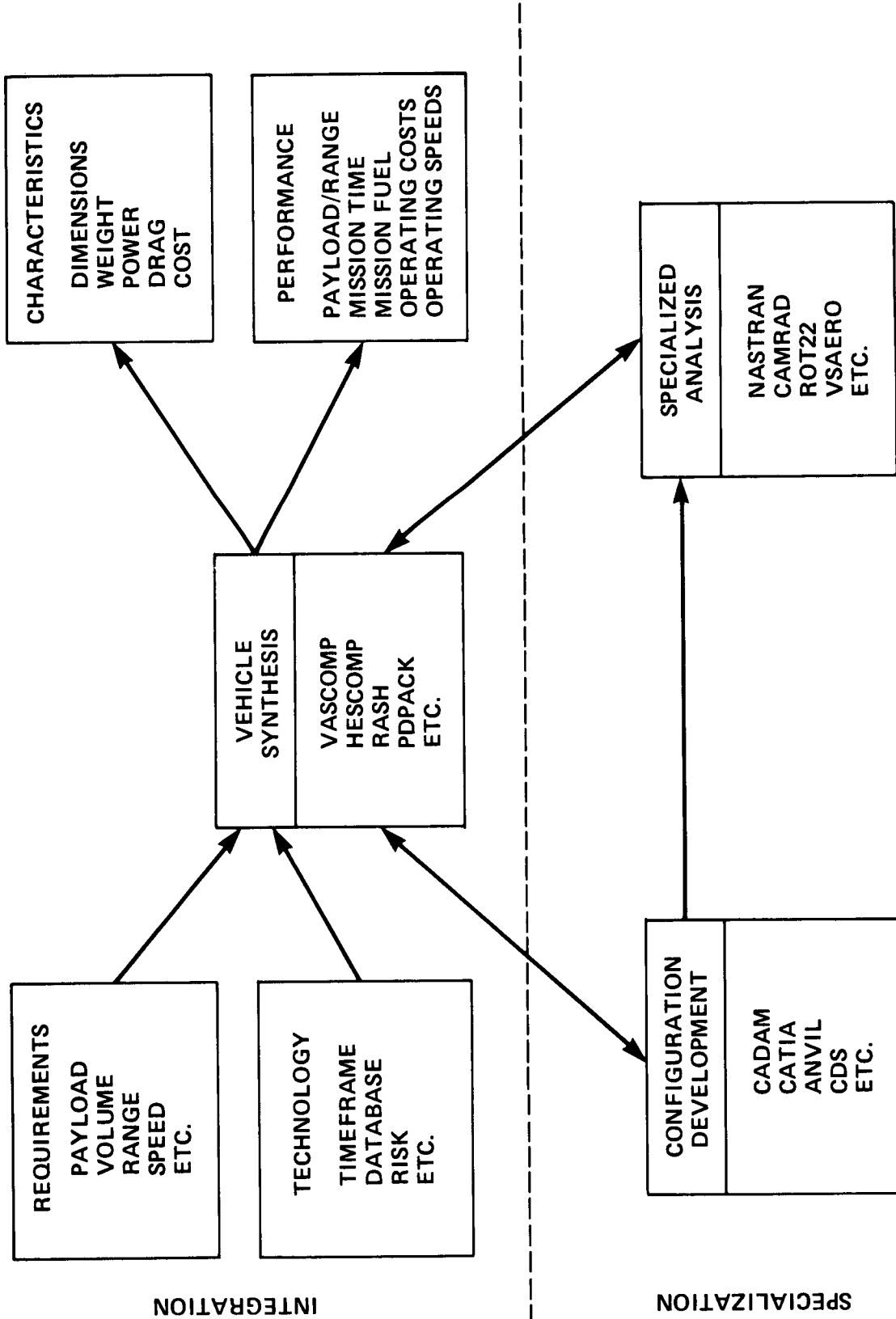

Figure 5.

HIGH SPEED CIVIL TRANSPORT DESIGN

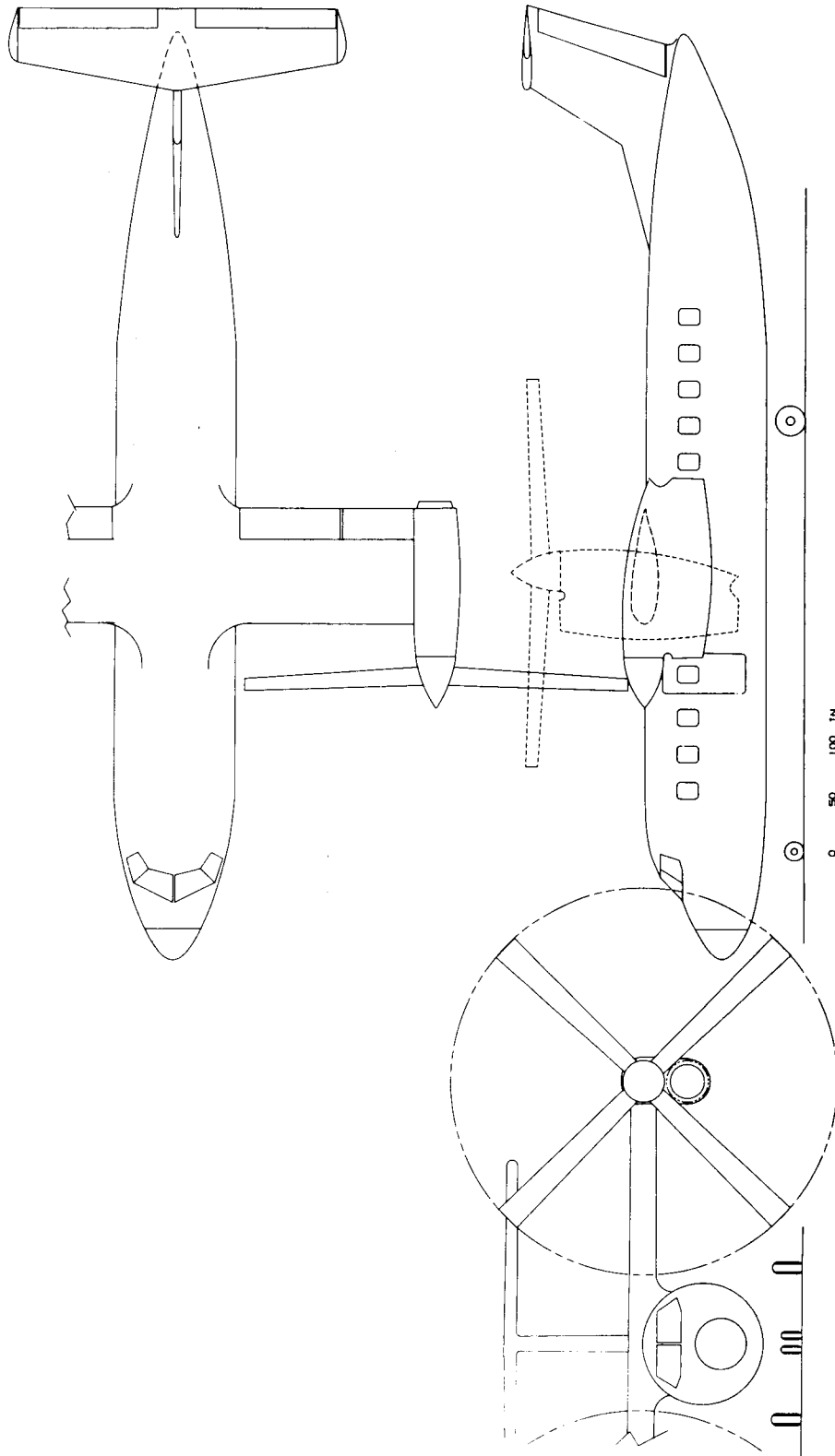

Figure 6.

HIGH SPEED AIR-COMBAT FIGHTER DESIGN

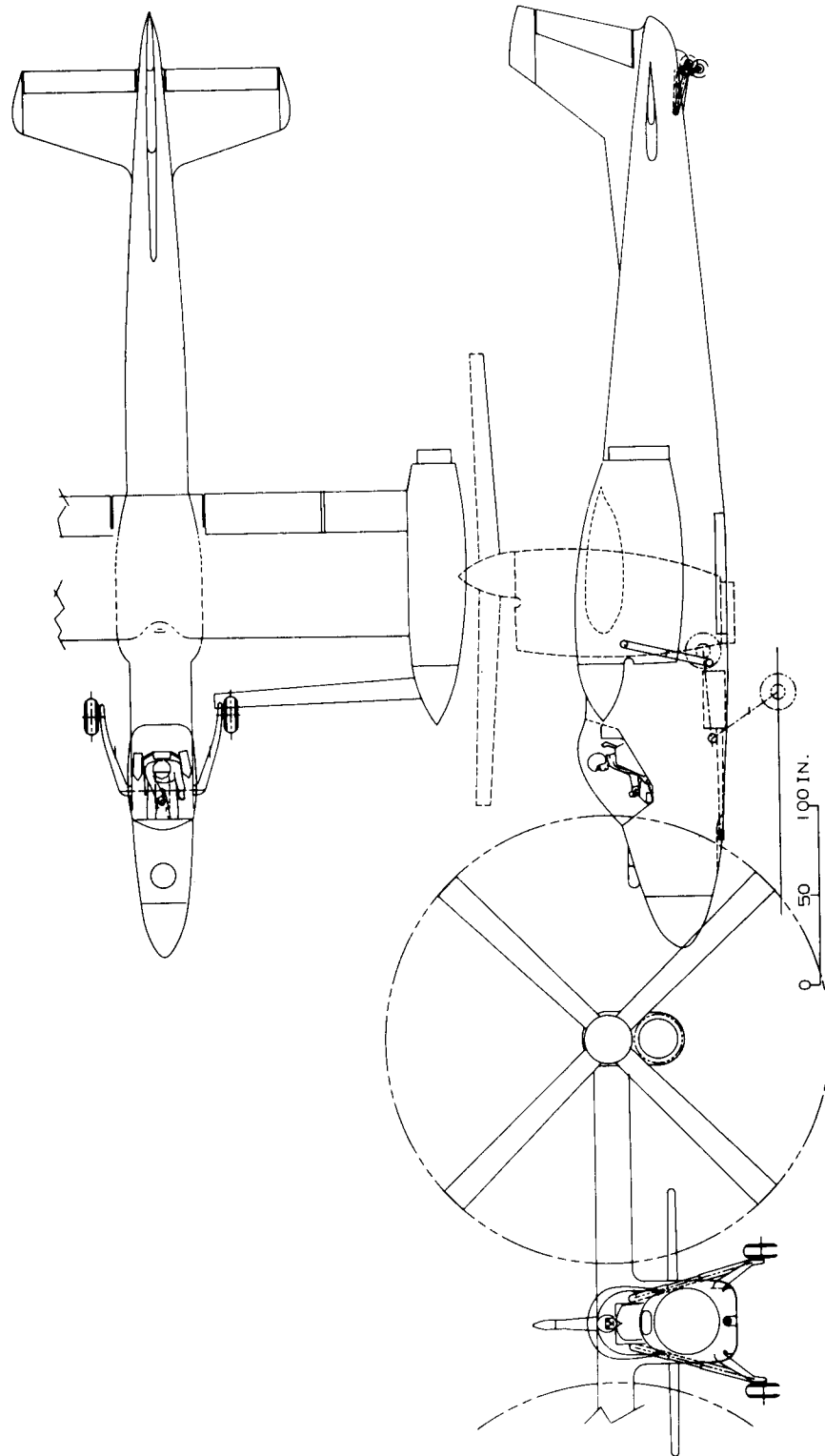

Figure 7.