

N88-17700

Protein-Crystal Growth Experiment  
(Planned)

S. Fujita, K. Asano,  
T. Hashitani, T. Kitakohji,

FUJITSU LABORATORIES LTD.  
10-1 Morinosato-Wakamiya,  
Atsugi 243-01, Japan

and

H. Nemoto and S. Kitamura

FUJITSU LIMITED  
1015 kamikodanaka, Nakaharaku  
Kawasaki 211, Japan

ABSTRACT

To evaluate the effectiveness of a microgravity environment on protein-crystal growth, we developed a system using 5-ft<sup>3</sup> Get Away Special (GAS) payload canister. In our experiment, protein (myoglobin) will be simultaneously crystallized from an aqueous solution in 16 crystallization units using three types of crystallization methods, i.e., batch, vapor diffusion, and free-interface diffusion. Each unit has two compartments: one for the protein solution and the other for the ammonium sulfate solution. Compartments are separated by thick acrylic or thin stainless steel plates. Crystallization will be started by sliding out the plates, then will be periodically recorded up to 120 hours by a still camera. The temperature will be passively controlled by a phase-transition thermal storage component and recorded in IC memory throughout the experiment. We can thereby evaluate microgravity environments for protein-crystal growth by comparing crystallization in space with that on earth.

INTRODUCTION

Recent advances in space transportation systems have opened the way to using environments in space, such as microgravity, ultra-high vacuum and cosmic radiation. Biotechnological use shows promise of being one of the most fruitful of the many application proposed thus far.

Determining the three-dimensional structure of protein is a basic and vital step in developing new technology, protein engineering, to improve some protein functions. X-ray diffraction analysis of protein crystals is

currently the most reliable way of determining protein structures, because it enables us to determine the absolute atomic coordinates of protein. The technique has significant problems, however, such as the nonreproducibility of nucleation and the difficulty in making well-ordered protein crystal enough for high resolution X-ray diffraction analysis.

Although, as yet, there is no effective way of controlling protein-nucleation, Littke and John<sup>1)</sup> recently reported that a microgravity environment accelerates crystal nucleation. Disorders caused by convection can conceivably be eliminated in a microgravity environment that is free of convection and sedimentation<sup>2)</sup>. It is here that working in space becomes of interest.

The G-459 payload, protein crystallization experiment system, was sponsored by The Mechanical Social Systems Foundation, and development was done by Fujitsu Limited in cooperation with Fujitsu Laboratories Ltd. The experiment in space will be done by Society of Japanese Aerospace Companies in cooperation with Fujitsu Limited.

## OBJECTIVES

The objectives of the project are to evaluate the usefulness of a microgravity environment in growing protein crystal and to determine which of the methods explored is most effective.

To achieve these objectives, we will attempt to crystallize protein, simultaneously, using three methods, and photograph nucleation and crystal-growth processes. We selected myoglobin because it crystallizes easily, has a brownish color that makes it easy to observe and is stable for months in an aqueous solution.

## PROCEDURES

Protein, as a polyionic electrolyte with a high molecular weight and a unique three-dimensional structure, can be crystallized from a moderately supersaturated aqueous solution by salting out. Supersaturation is achieved several ways including batch, equilibrium dialysis, temperature gradient, vapor diffusion, and free-interface diffusion. We have chosen three of these for the experiment: 1. batch, in which protein and ammonium sulfate solutions are thoroughly mixed, 2. vapor diffusion, in which solutions are separated by a gaseous diffusion layer, and 3. free-interface diffusion, in which solutions contact in what is called free interface.

## STRUCTURE AND FUNCTION

Figure 1 gives the structure and Figure 2 the block diagram of the system, which includes lead-acid batteries, a sequence controller, IC memory, a still camera, and the experiment module. The system can perform experiments simultaneously for up to 120 hours. We have chosen a new option, called Baroswitch, for the GAS system, to extend the life of the experiment to the maximum. Figure 3 shows the experiment module, in which 16 crystallization units with sliding plates are set radially around a mirror rotated by one stepping motor for sequential observation of each unit. Sliding plates are linked to a triangular plate, just over the units, that can be driven by another stepping motor and three synchronously rotating ball screws to slide

the plates out.

The three groups of crystallization units are the same size but have structures differing with the crystallization method, as shown in Table 1. The batch and free-interface diffusion units are nearly the same, except for the batch unit's small magnet used to mix the solution in the initial stage. The unit for vapor diffusion has thick acrylic plates, instead of thin stainless steel plates to form an air gap between two compartments.

Crystals will be photographed periodically up to 120 hours with a still camera having a motor-driven film winder and a 30-foot film attachment. A ring-flash light just beneath crystallization units flashes synchronously with the flipping of the camera shutter. A lens is attached to a cover plate of the experiment module.

## THERMAL CONTROL

Crystal solubility and growth rate generally depend on temperature, it desirable to control temperature as precisely as possible. Restrictions on electricity led us to choose passive thermal control consisting of foam thermal insulator and a thermal storage component that use the exo- and endo-thermic phase transition reaction of inorganic hydrates. This protects crystals from the thermal fluctuation of the external environment and the heat generation accompanying battery discharge. Table 2 gives an example of hydrate composition. The transition temperature is adjusted by changing hydrate composition.

## PRELIMINARY EXPERIMENT



A stand-by period for the GAS system that lasts more than a few months may be a factor critical to the experiment's success, because long-term storage of the protein solution at room temperature is abnormal and may denature the protein. This make it vital that we thoroughly examine the stability of the protein solution.

Figure 4 shows crystals grown in the crystallization unit by free-interface diffusion from a freshly prepared myoglobin solution.

## REFERENCES

- 1) W. Littke and C. John, *Science*, 225, 203-204 (1984)
- 2) L. J. DeLucas, F. L. Suddath, R. Snyder, R. Naumann, M. B. Broom, M. Pusey, V. Yost, B. Herren, D. Carter, B. Nelson, E. J. Meehan, A. McPherson, and C. B. Bugg, *J. Cryst. Growth*, 76, 681-693 (1986)

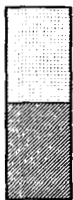
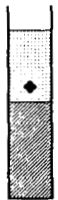
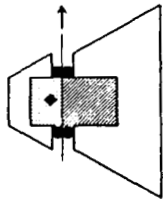
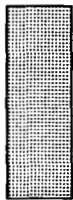
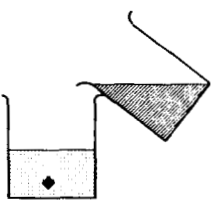
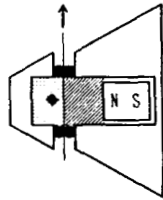
Table 1 Crystallization methods

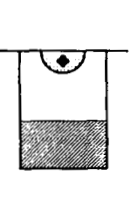
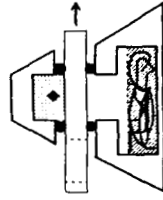
Method	Principle	On Earth	In Space
Free-interface diffusion			
Batch			
Vapor diffusion			

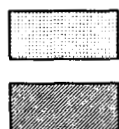

Protein solution

Precipitate solution



Mixture

Table 2 Thermal storage component composition

Hydrate	Content (wt%)	Transition Temperature (°C)
CaCl <sub>2</sub> · 6H <sub>2</sub> O	88	} 25 ± 0.5
MgCl <sub>2</sub> · 6H <sub>2</sub> O	9	
Ba(OH) <sub>2</sub> · 8H <sub>2</sub> O*1	3	

\*1: As nucleator

ORIGINAL PAGE IS  
OF POOR QUALITY

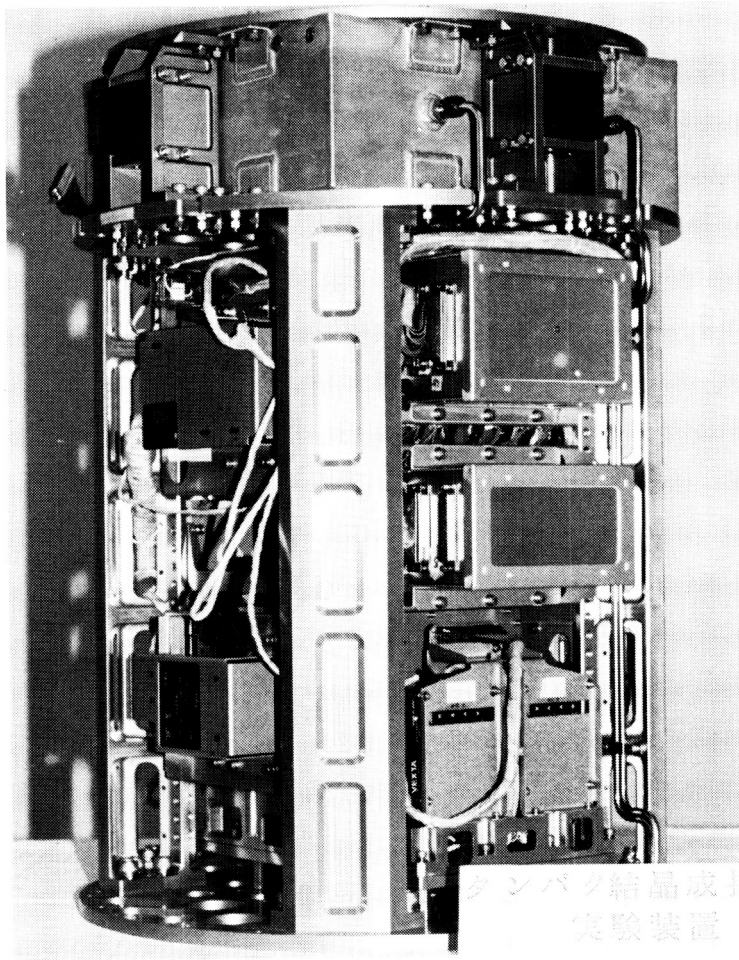

Figure 1  
G-459 payload

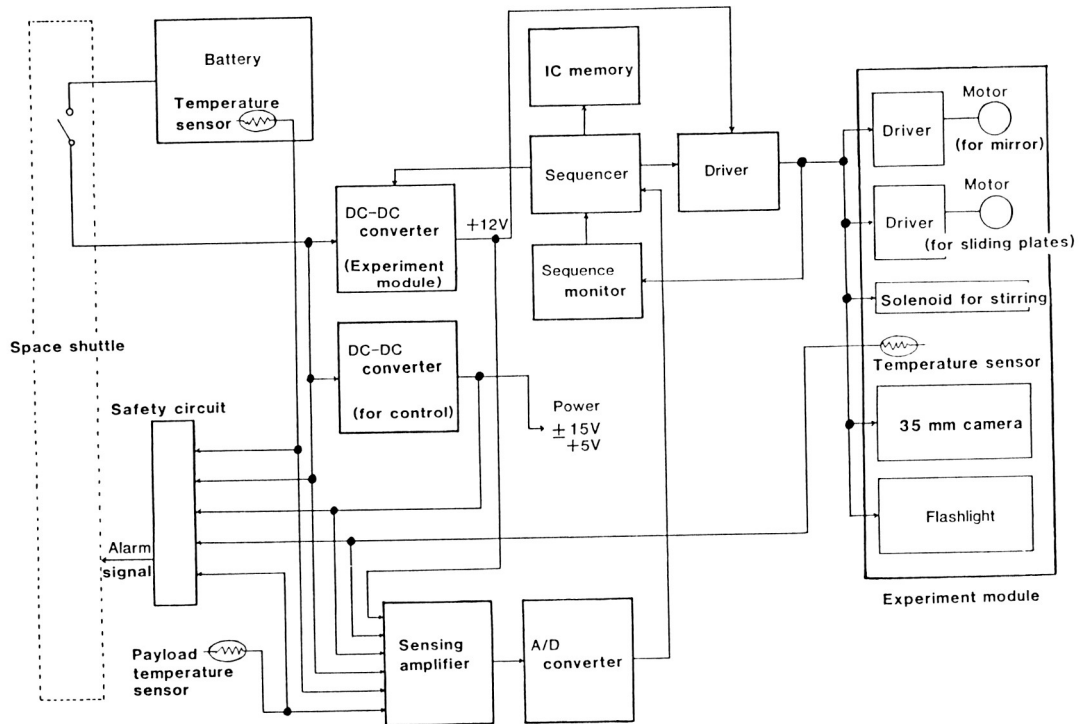

Figure 2 Block diagram

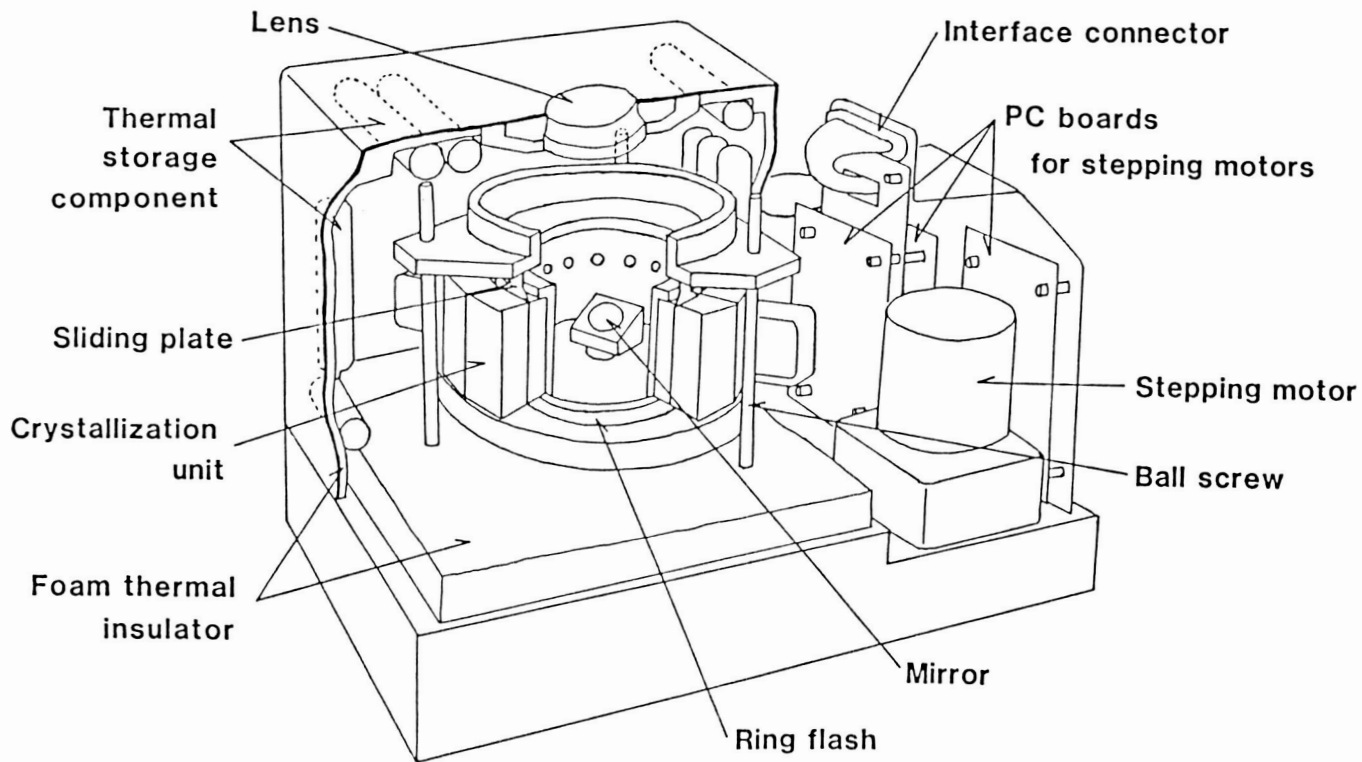

Figure 3 Experiment module

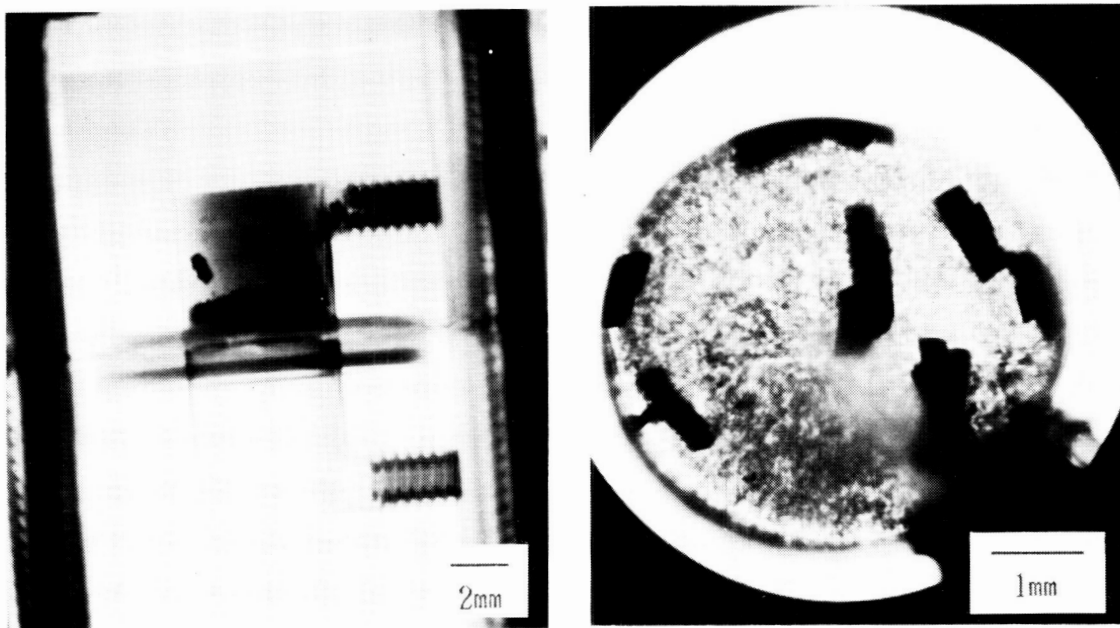

Figure 4 Crystals grown in the crystallization unit