

NASA Technical Memorandum 100696

Deformations in VLBI Antennas

(NASA-TM-100696) DEFORMATIONS IN VLBI
ANTENNAS (NASA) 96 P CSCL 20K

M88-18970

Unclas
G3/39 0129400

T. A. Clark and P. Thomsen

JANUARY 1988

The NASA logo, consisting of the word "NASA" in a bold, italicized, sans-serif font.

NASA Technical Memorandum 100696

Deformations in VLBI Antennas

T. A. Clark

*Goddard Space Flight Center
Greenbelt, Maryland*

and

P. Thomsen

*Interferometrics, Inc.
Vienna, Virginia*

NASA

National Aeronautics and
Space Administration

Goddard Space Flight Center
Greenbelt, Maryland 20771

1988

Contents

I	Structural Analysis with GIFTS on an Antenna	3
1	Introduction	3
2	Drawings	3
3	An overview of GIFTS	4
3.1	BEAMCS	6
3.2	EDITM	6
3.3	LOADBC	8
3.4	OPTIM	11
3.5	Macro EASY	12
3.6	RESULT	12
4	More useful features	13
5	Substructures	16
6	Program PARABOL	17
7	Program WINDLOAD	20
8	APPENDIX A: Listing of program PARABOL	23
9	APPENDIX B: A full run of PARABOL	30
10	APPENDIX C: Listing of program WINDLOAD	35
11	APPENDIX D: A full run of WINDLOAD	38
II	Path Length Changes in an Antenna	41
12	Introduction	41

13 The paraboloid	41
14 Changing the paraboloid	43
14.1 Estimation of α_R	44
14.2 Deviations from a paraboloid	46
15 Changes due to gravity	53
16 Changes due to temperature	55
III The Antenna at Fairbanks, Alaska	59
17 Introduction	59
18 Description of the antenna	59
18.1 Drawings	59
18.2 Material	60
18.3 The major structural parts of the antenna	60
19 Forces and deformations	66
20 Models	67
21 Calculated deformations	71
21.1 Gravity	71
21.1.1 The quadrupod	71
21.1.2 Results from the substructure model	75
21.1.3 The dish	80
21.1.4 Pointing corrections	85
21.2 Temperature	85
21.2.1 Substructures	87
21.2.2 The dish	87
21.3 Wind	90
22 Measurements	90
23 Conclusions for the Fairbanks antenna	94

Part I

Structural Analysis with GIFTS on an Antenna

1 Introduction

This is the first part in the report on the project that has studied antenna structures. The aim of the project has been to estimate deformations in the large antennas that are used in the VLBI project. As a test antenna the 85 foot dish in Fairbanks, Alaska was chosen.

It was immediately clear that a finite element code was needed. Such codes are now available for PCs. Several different packages exist and these were studied in detail, and it was easy to get free demos. The one I found most impressive was GIFTS. It's an interactive program and very easy to learn. The graphics is very nice and without it the task would have been much more difficult. GIFTS was installed on June 1, 1987. It's a program for both mainframes, such as IBM and DEC, and PCs. The version used in this project is installed on a PC - a COMPAQ/386. The micro processor is an Intel 80386 clocked at 16 MHz, and the coprocessor is a 80287. The PC also has a 70 Mb hard disk drive.

The aim of this part is to describe the use of GIFTS and especially its application on an antenna model and to communicate some tricks of the trade. However, to actually do work with GIFTS the GIFTS Users Reference Manual (Ref. 1.) will have to be consulted for the exact syntax of these commands. The part only presents the most used commands and when to use them. This means that a lot of the capabilities will go unmentioned. This report also describes some programs written especially for this project and how to use them.

2 Drawings

Good drawings are of such importance that a section on it is warranted. To make a model and an analysis of an existing antenna a lot of information

is needed. First one needs to know the material used in various parts of the antenna. The material is often steel and sometimes aluminum. A code for the material according to ASTM (American Society for Testing and Materials) is very useful: one can then use tables listing the properties of this particular steel. Secondly, one needs to know the dimensions of the structure. Furthermore, one needs to know the coordinates for every point where two beams are joined, the so called nodes. An antenna is a very complex structure with thousands of different beams joined together. All these beams have different crosssections according to their place in the antenna. Finally, one needs information on these crosssections.

The best source of information is the actual design drawings. However, the antennas are sometimes more than twenty years old and it can be very hard to obtain drawings on these. Furthermore, the antennas sometimes have undergone major renovations that have led to modifications of the structure. Drawings of these are then also needed.

The alternatives are to use photos, which will at least give approximate coordinates of the nodes, and measurements on the actual antenna. This will, however, result in a less accurate model, because a lot of information can not be obtained this way.

3 An overview of GIFTS

The GIFTS program consists of several different processors. Each processor performs a special task (e.g. applying loads to a structure or defining boundary conditions). These processors have to be run in a certain order in a complete analysis.

A brief description of an analysis of an antenna is as follows. From a detailed set of drawings crosssections of the different beams are defined. The coordinates of the nodes (the point where beams are joined together) are entered. The beams and their orientation with the correct crosssection are specified - in the language of finite element analysis: the elements are defined. Then boundary conditions are entered (e.g. nodes that are not moving because they are rigidly linked to the ground). Forces are applied. This can be for example gravity or thermal loads. GIFTS then solves a large matrix equation and the result is deformation (and stresses) at all

nodes.

Now all of the different steps described above are performed by a specific processor, some by the same. The analysis is simplified by the use of batch files that call different processors automatically. These batch files are easy to modify for the application that one is interested in. However, the actual specification of the model has to be done "by hand", but there are a lot of tricks that simplify this work.

Aside from calculating deformations there is also the possibility of doing dynamic analysis, extracting eigenfrequencies in the structure, calculating heat transfer and doing gap analysis. Larger models are made easier to handle by the use of substructures.

All relevant processors needed for the study of an antenna are installed on the D: drive in directory GIFTS. (There are still more processors on the floppy disks that contains the complete program, e.g. solid elements, but these are not installed to save disk space.) The work on models is recommended to be done in subdirectory JOBS to protect the program. Each job has many files with the same name - the jobname one chooses - but with different extentions (e.g. dish.blk, dish.ptr ...). To enter a processor one just types its name, and one will then be prompted for the name of the job one wishes to work on; to exit a processor one types QUIT.

There are two types of processors: interactive and computational. The interactive are used to build the model, define loads and boundary conditions; in each interactive processor there is a set of commands one can use. The computational processors do not accept commands from the user, they just perform a part of the calculation needed to compute the deflections. To some extent it's possible to go back and forth between the different interactive processors, but some require that certain tasks have been accomplished before they are used. The computational processors can only be run in a specified sequence.

A big model requires a lot of commands in the interactive processors. GIFTS has the capability of using what GIFTS calls "ON-LINE-BATCH", command OLB, which makes it possible to make a file (with for example EDLIN or WordStar) and then run it through the processor. These files should have the extension .SRC. It's a very nice feature; it's possible to insert comments about the model in these files which gives them structure and makes them easy to understand. The file also saves all the work one

has made on the model and can at a later time be changed and improved. In the following section the most used processors will be described.

3.1 BEAMCS

BEAMCS is a processor that one uses when one wants to specify the cross-sections of the beams in the antenna. In this connection it's useful to have a copy of the AISC (American Institute of Steel Construction) Steel Construction Manual that contains the dimensions and codes for all standard beam crosssections.

There are of course different types of crosssections. The most common in antennas have been tbeams, angles, ibeams and circular and rectangular tubes. The commands used are TBEAM, ANGLE, IBEAM, CIRCS, CIRCH and RECTS. Each crosssection one enters is identified with a number that later is used to refer to it. After the crosssection is defined it's useful to plot it, see Figure 1. Note the P and Q axes that define the principal axis of the moment of inertia. Also note the direction that helps to orient the crosssection in the model. For further discussion on this see the next section on EDITM. In the figure the point A which is the attachment point to the node. The attachment point can through special commands be moved to suit the use.

3.2 EDITM

The processor EDITM is the one that is used the most while working on an antenna model. With this processor one specifies the nodes and how they are connected with each other through different beams.

But first of all, it's important to know what coordinate system one uses. The global one - the one used if no commands specifying another are present - is a cartesian coordinate system. With the command LOCSYS it's possible to change the coordinate system to cylindrical, spherical or a different cartesian coordinate system with different orientation and origin. These coordinate systems can be used on different parts of the model and are a great help to simplify the work. For example, when working on an antenna dish a cylindrical coordinate system is excellent.

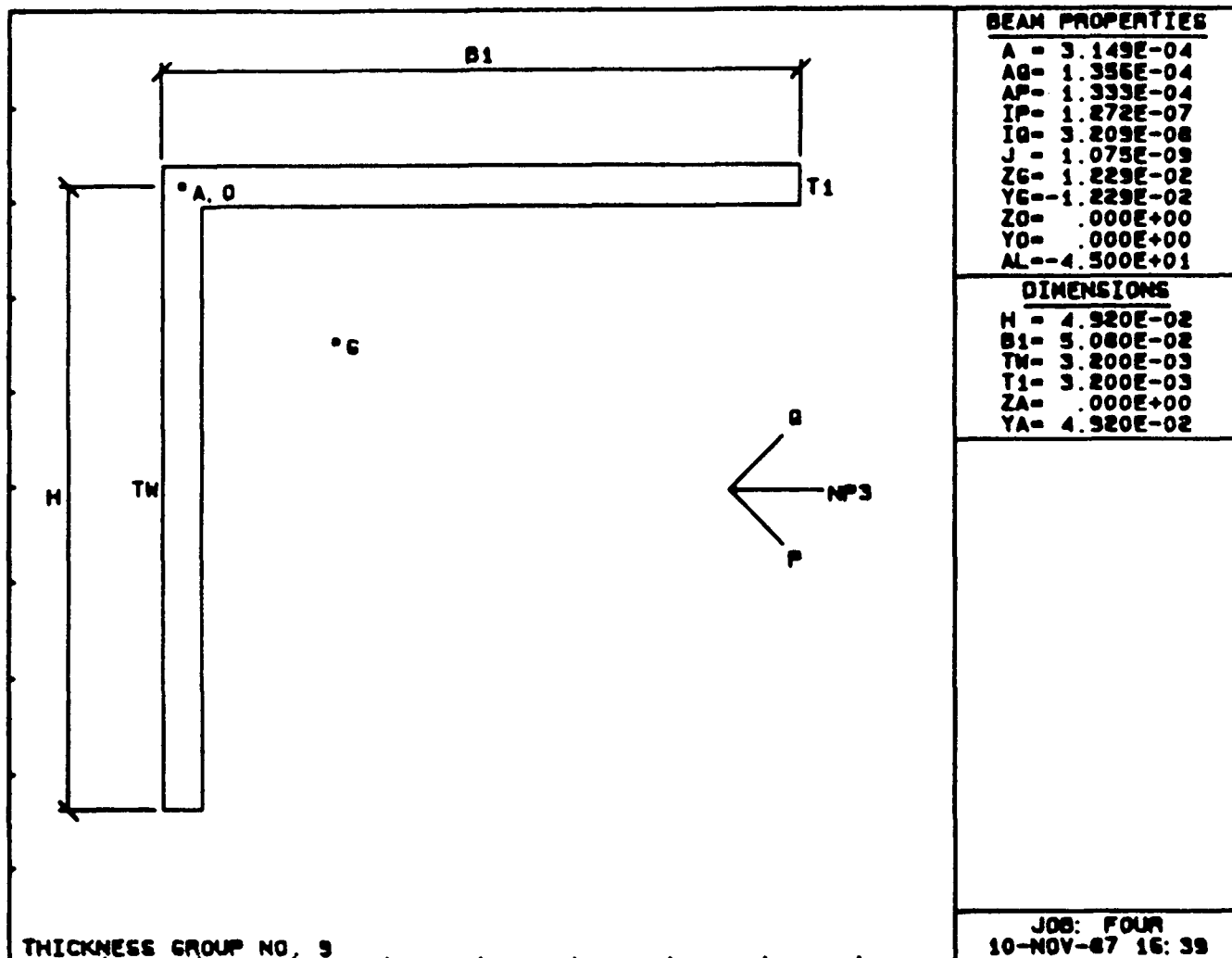

Figure 1: A plot of a crosssection (ANGLE) defined in processor BEAMCS. Note the principal axes P and Q and the direction NP3. The latter is important when one defines the orientation of the crosssection in the model. The table contains information on the dimensions and the mechanical properties.

After a suitable system has been chosen the nodes can be specified. This is done with the command POINT. Each point is defined by a number that is used to refer to it and the coordinates. Command POINT/11/1,2,3/ defines point 11 at (1,2,3). One can also use a repetitive command

POINT/11,13,3/1,2,3/3,6,9/

which defines points 11, 12 and 13 at (1,2,3), (2,4,6) and (3,6,9). This is very useful in a dish defined in a cylindrical coordinate system where there is a lot of repetition around the axis of symmetry.

It's also important how one numbers the nodes, see Figure 2. for a useful way to number nodes in a dish. The trick is to have some logic or system in the numbering that makes it easy to remember where different nodes belong. Believe me, when the number of points gets large it gets really hard to keep track of them. Preferably, one should also keep some notes for later reference on how the numbering was done.

When all nodes are specified it's time to start connecting them with beams. First one chooses the material in the beam with the command PTRM and the cross-section with the command PTRTH. Finally, the command BEAM2 is used to specify the beam. BEAM2/1,2,3/ defines a beam between nodes 1 and 2 with the reference point in the cross-section NP3 in the plane spanned by nodes 1, 2 and 3. See Figure 3. and note the orientation of the beam cross-section and the command sequence.

The command PLOT plots the model and it's possible to plot different cross-sections in different colours. WI lets the user zoom in on a desired point. There are commands that rotate the model ROTV and introduce perspective (VDIST). All these are wonderful when one wants to check the model.

3.3 LOADBC

After one is finished with BEAMS and EDITM the model is ready for application of loads and boundary conditions. This is done in processor LOADBC.

Certain points in the model have to be attached rigidly to the reference frame, i.e. their deflections are prescribed to be zero. If not, the matrix in

ORIGINAL PAGE IS
OF POOR QUALITY.

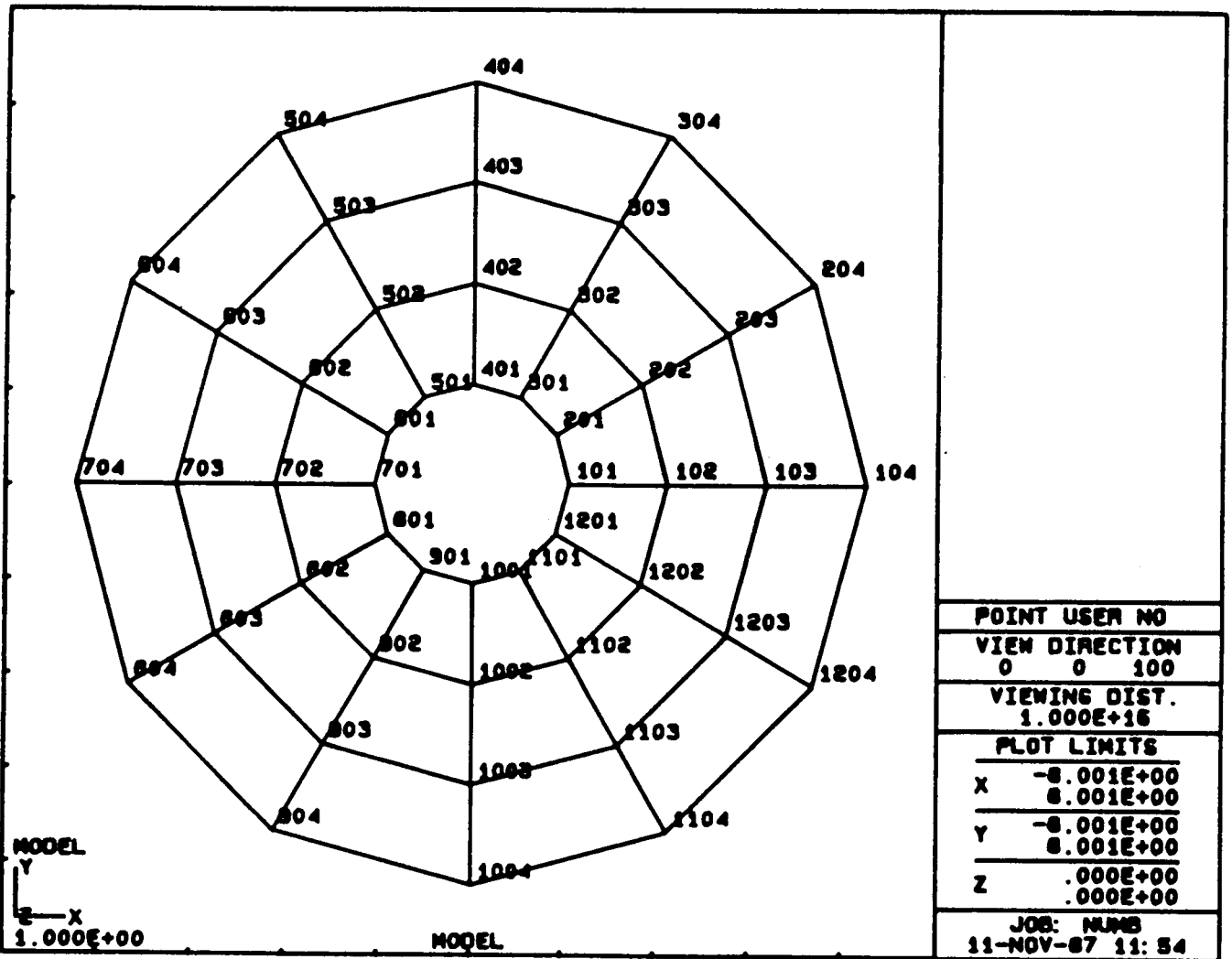

Figure 2: This is a useful way to number the nodes in an antenna dish. (One is looking into the dish from the receiver.) It's important to have some system in the numbering; it makes it easier to remember where different nodes belong.

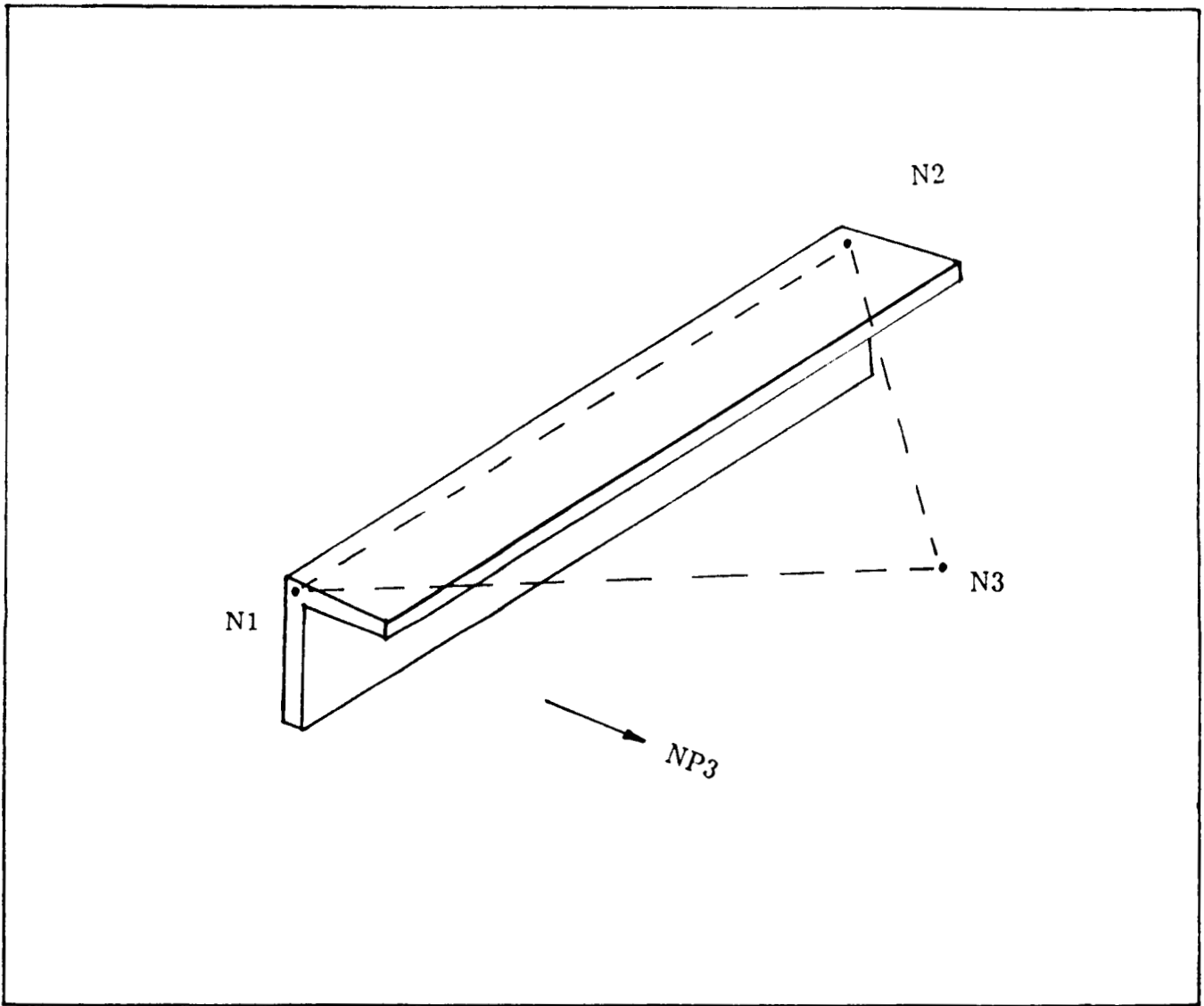

Figure 3: There is an important relationship between the command sequence `BEAM2/N1,N2,N3/` and how the beam is oriented. This is illustrated in the figure. The beam is connected between nodes N1 and N2 and the direction NP3 (see Figure 1.) points towards node N3.

the equation is singular. This means that the model collapses or that it is possible to rotate or translate the whole or some part of the model without resistance. The points that are chosen to be fixed are suppressed with the command SUPP. Other more selective commands that only suppress some of the six degrees of freedom in the nodes (three rotations and three translations) also exist.

Gravity loads are applied by using the command TRANACC that applies an acceleration of specified magnitude and direction to the model. Before this is done the mass of the model has to be calculated, done with command MASS. This command uses the density in the specified material and the lengths and crosssections in the beams. It's also possible to apply point masses with command PMASS.

Loads due to changes in temperature are applied in two steps. The command PTEMP specifies the temperature in the nodes. The beam between two temperatures is assumed to have the average of the two temperatures. To get the actual loads in the structure one has to exit LOADBC and use processor THERLD which calculates the forces due to the thermal expansion.

Finally, the command LOADP makes it possible to directly apply a load at a desired node.

3.4 OPTIM

As mentioned before the deformations in the structure is calculated by solving a matrix equation. Let's write it

$$F = K\delta \tag{3.1}$$

where δ is a vector of the deformations that one wishes to calculate, K the matrix representing the stiffness of the model - called the stiffness matrix - and F a vector containing the loads applied to the model. The purpose of OPTIM is to reduce the time it takes to solve this equation to a minimum.

The time it takes to solve Eq. 3.1 is proportional to the square of the matrix bandwidth and to the number of unknowns. The number of unknowns is the number of nodes times the number of degrees of freedom of deformation at each node (as mentioned before: three rotations and three translations). The number of unknowns cannot be changed. However, it's

possible by renumbering the nodes in a smart way to reduce the bandwidth, and this is exactly what OPTIM does.

The bandwidth of a matrix is small when the nonzero elements are close to the diagonal. One achieves this by numbering nodes that are connected to each other with numbers that are close. OPTIM requires a starting "wavefront" a set of nodes to start renumbering from. Then OPTIM works its way through the model like a wave to the connecting nodes and renumbers them sequentially.

Trial and error is the best way to minimize the bandwidth; one can enter several wavefronts in OPTIM and then OPTIM chooses the best one. One general rule one can use is that wavefronts at short edges of the model are generally good.

3.5 Macro EASY

EASY is a batch file that calls the processors ADSTIF,ELSTFF and STASS that calculates the stiffness matrix \mathbf{K} . Then it calls DECOM the processor that inverts the matrix, and finally it calls the processor DEFL that calculates the deflections. All these processors are computational.

There is the possibility of using other macros, e.g. MSTATIC that in addition the above also calculates the stresses in the beams.

3.6 RESULT

This processor is used to view the results of the calculation. One uses the same plotting commands mentioned in the section about EDITM. The structure is plotted with the deformations exaggerated but still in scale. PLOT,1 plots the deformed structure with the undeformed structure outlined, and INF DN lists the deflections at desired nodes.

A nice feature when studying antennas is the possibility of making contour plots of deformation in the dish surface. This is done with the command CONTOUR. This requires however that one has specified plate elements, e.g. TB3, in the surface, because these are needed to calculate the contours.

4 More useful features

This section contains comments on some more processors and commands that are useful.

After a complete analysis all the files can take up a lot of disk space, sometimes the whole disk. If one wants to save the results for later use one can use the processor DBCOND that compresses the files (e.g. 20 Mb to 1Mb).

In EDITM, where as mentioned before the major part on the antenna is done, there are some more useful commands. When the model gets large it's sometimes useful to plot the outline of the structure. These lines are defined with the command PLOTLINE. One can switch between plotting lines or elements with the commands LINES and ELE. Another way to get a better view of the model is to use the command sequence ELE,25 that shrinks the elements 25 percent in the plots.

In LOADBC there are also a variety of useful commands. When the model has symmetry it's not necessary to model the complete structure. It's sufficient to use just one part of the model, see Figure 4. The command SYM or ASYM applies the correct boundary conditions at the cut. Which one one should use depends on the loads. In the situation in Figure 4. one should use SYM because the forces are also symmetric with respect to the cut. If the forces were horizontal then one should use ASYM. Another very useful command is LDCASE. This makes it possible to switch to a different loading case and to calculate the deflections due to different load situations in the same analysis. The results can then later be combined. For example, an antenna dish moves through different elevations. If one defines load case 1 to be when the antenna points at the zenith and load case 2 to be when it points at the horizon, see Figure 5, then forces at different elevations are a linear combination of these two cases. And because Eq. 1 is a matrix equation, the deflections are also the same linear combination of the calculated deflections for the two loading cases. The combination of the deflections from the different load cases is done in RESULT with command COMP.

One can plot the models and print information with special commands. To plot a model one selects a nice view of the model and then types HCON. One is then prompted for a name of the output file; let's call it PIC. Then

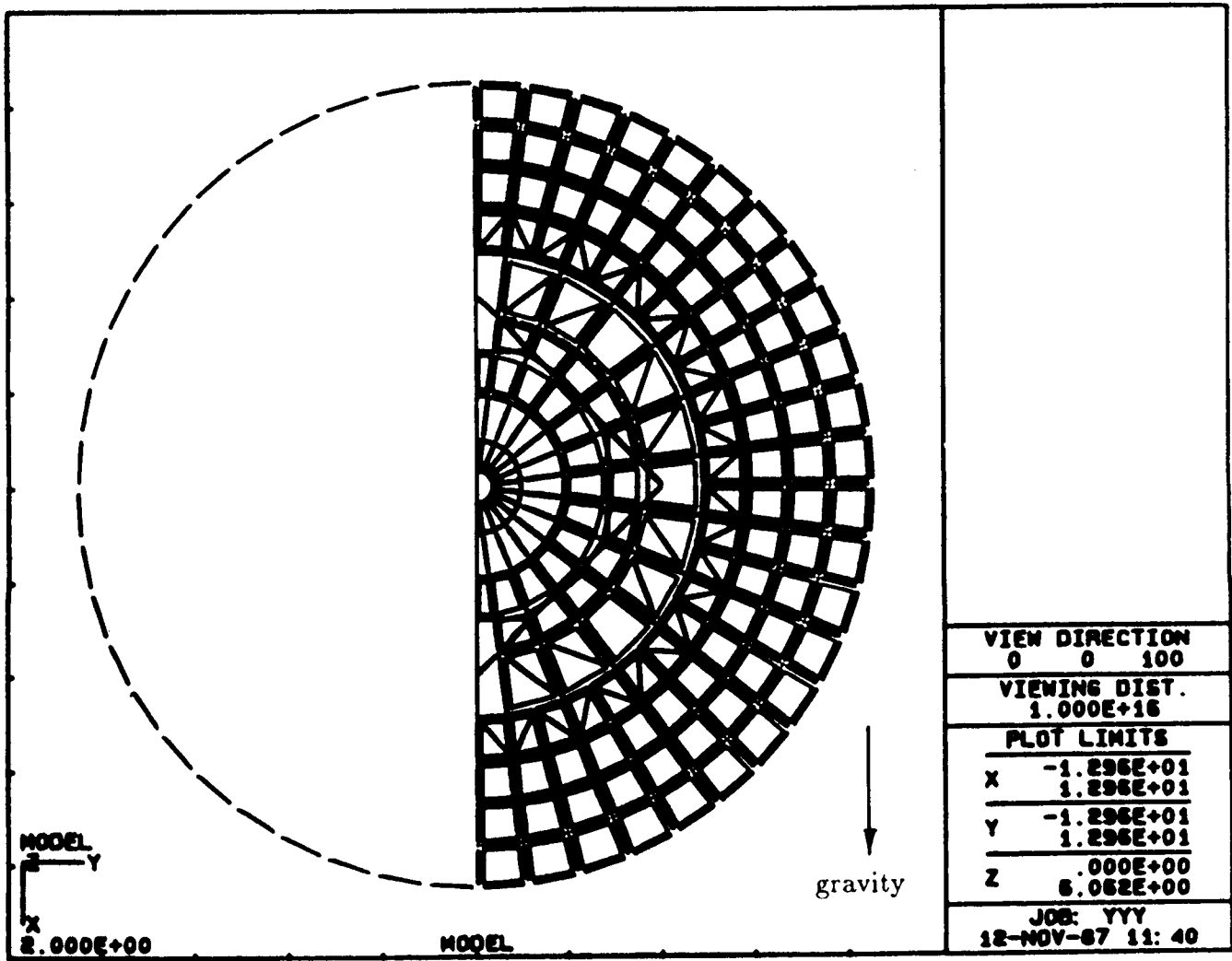

Figure 4: When there is symmetry in the model only part of it needs to be modeled. It's enough to model just half an antenna dish. The gravity loads, direction downward, are also symmetric around the cut, and boundary conditions are applied along the cut with command SYM.

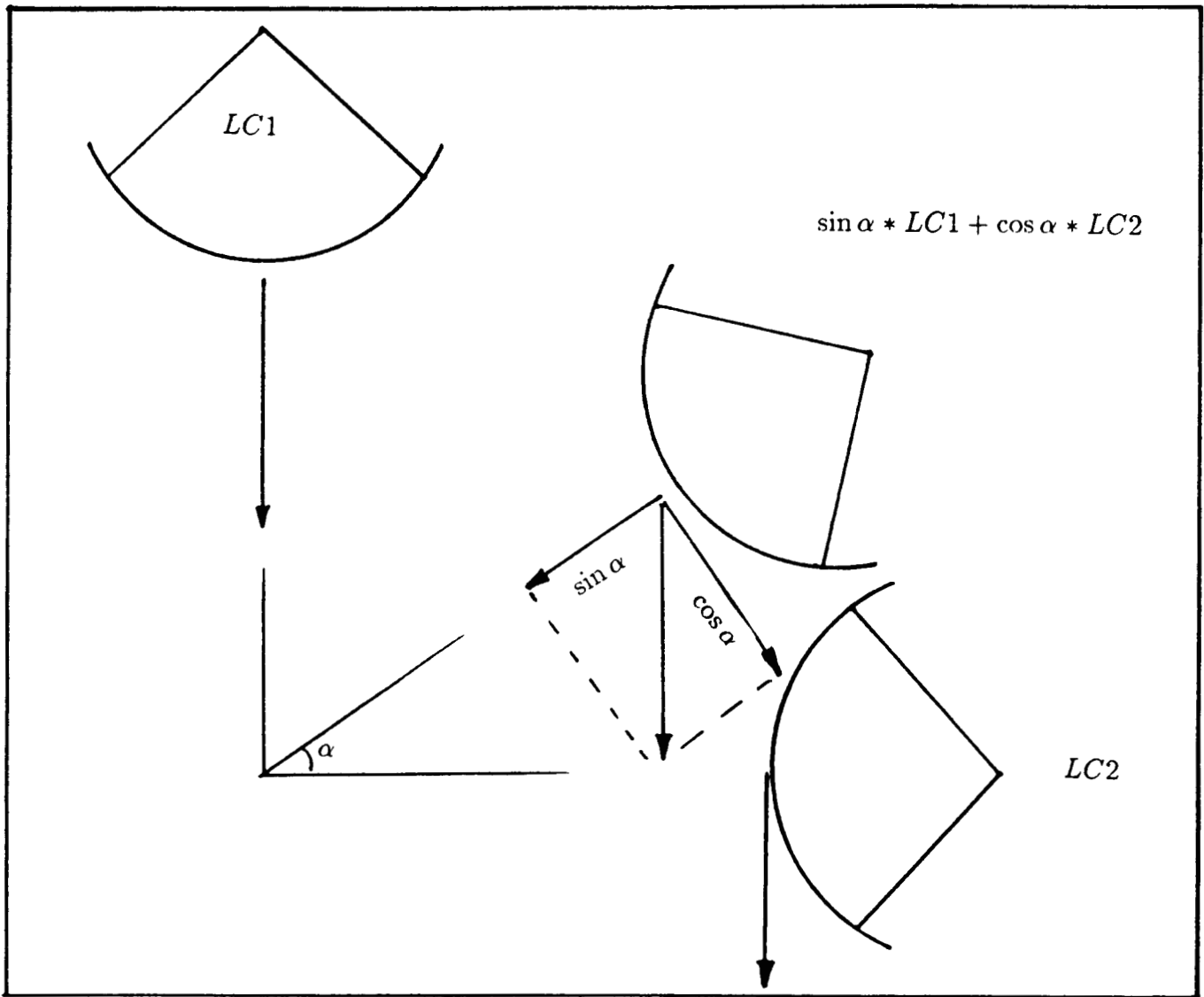

Figure 5: The forces due to gravity in an antenna at different elevations are a combination of two load cases. The force at α elevation is $\sin \alpha * LC1 + \cos \alpha * LC2$. Call the deflections calculated for the two load cases $DF1$ and $DF2$. Then the deflection at α elevation is $\sin \alpha * DF1 + \cos \alpha * DF2$.

one types PLOT and the information is written to PIC.HCY. When one is finished one types HCOFF. GIFTS has several processors that transform PIC.HCY into a file PIC.P01 that can be sent to a plotter. DRHP is used for the HP 7475 in the computer room; DRHI is used for the Houston Instruments DMP-40 in Bill Boyers office. Copy PIC.P01 on a floppy and put it in drive A of the computer that is connected to the desired plotter. To send the file to the plotter type: COPY A:PIC.P01 COM2.

If one wants to list information to the printer type LPON. All the commands thereafter that list information will send the information to the printer connected to the COMPAQ. When one is finished one types LPOFF.

5 Substructures

The model of the Fairbanks antenna was done in several steps. Each major part of the antenna (pedestal, x-wheel, y-wheel, dish and quadrupod) was modeled separately. It's possible to use some of these src-files in the same job - the files have to be carefully done so there are no overlapping numbering of points or crosssections, and the coordinate systems have to be carefully chosen. This is like running a very large src-file in small steps. The model becomes quite big, sometimes too big for the PC to handle.

The other alternative is building the total model with substructures. The substructure idea is to make the inversion of matrix K in several minor steps, or to consider the major parts (consisting of a lot of elements) as one big element. Take for instance the x-wheel; it's connected to the pedestal at two points and to the y-wheel at another two points. It can be thought of as an element having four points where it can be connected to nodes. Calculating the properties of this element is nearly the same as doing a part of the big matrix inversion.

Suppose the model of the x-wheel is finished and that one wants to make a substructure out of it. Here's the way. Build the model with BEAMCS and EDITM. Apply loads *but no boundary conditions*. Run OPTIM and then DEFCS; this is the correct order and not mentioned in the manuals. This processor allows one to give the substructure a name, e.g. xwheel, and to define the external points. External points are those points one later wants to connect to other elements. Then calculate the stiffness matrix and

decompose it. Finally run REDCS. This processor calculates the properties of the substructure and transformations between the reduced properties and the full model. This makes it possible, when one knows the deformations in the external nodes, to calculate the deformations in the whole structure of the x-wheel.

The substructure can now be used as a regular element in other models. Figure 6. shows a plot of the antenna consisting of several substructures. The substructures are plotted with lines between their external points. Instead of BEAM2 one uses the command COSUB to define the position of the substructure - element. Gravitational loads and masses should be computed before the substructure is calculated, otherwise the results get very strange. In the main model where the substructure is used the forces are transferred to it with the command LOADCS.

When the main model is finished and all forces and boundary conditions applied it is analysed as a regular model. As a result one gets the deflections in the external nodes. If one wants to examine the substructure in more detail one can use the processor LOCAL that calculates the deflections in the internal points. These are then examined in the processor RESULT.

The one major difficulty is keeping track of the orientation of the substructures and the numbering of the external points. Detailed notes are the best help.

6 Program PARABOL

Program PARABOL is a program that fits a paraboloid to a deformed antenna dish. The code was originated at JPL by S. Katow (Ref. 2-3). A listing of this program adapted in BASIC for the COMPAQ/386 is found in Appendix A, and in Appendix B there is a listing of a full run of the program. The program is installed in the same directory as GIFTS (drive D:, directory GIFTS). PARABOL.EXE contains the executable file and PARABOL.BAS contains the code. In addition to the code for the best fit paraboloid, code has been added to manage files and to calculate the change in average pathlength to the receiver.

To calculate the best fit paraboloid PARABOL needs the calculated deformations at the nodes that lie at the dish surface. This is done in two

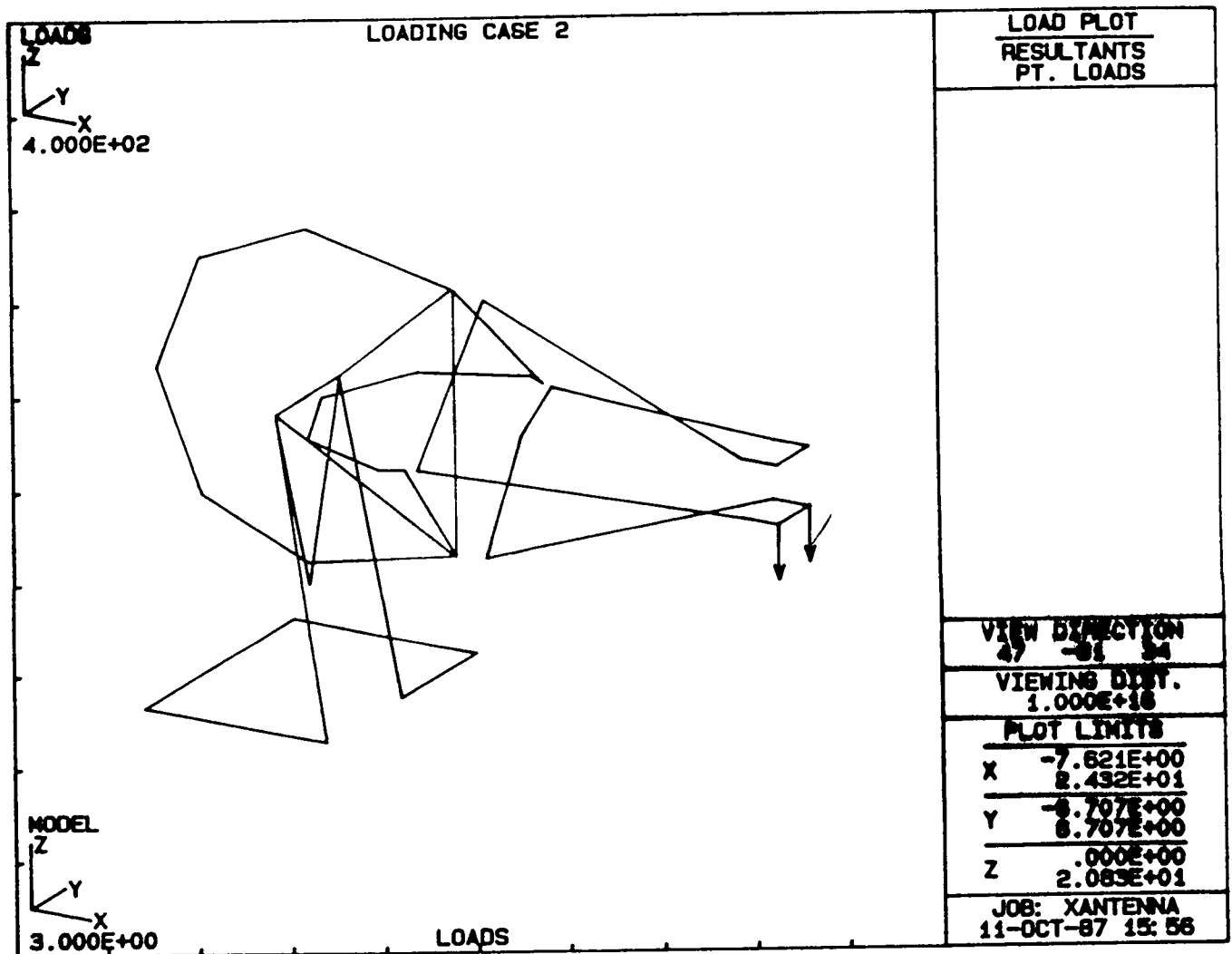

Figure 6: This is a plot of a model consisting of four substructures (pedestal, x-wheel, y-wheel and quadrupod). These substructures internally consist of many elements. They are plotted with lines connecting their external nodes - the nodes that can be connected to other elements and substructures. Note the forces plotted as arrows.

steps. First one has to use the processor GFTOUT in the GIFTS package. GFTOUT is a processor that writes data from the GIFTS files to ASCII files. It's possible to select a lot of different data and formats with the processors commands. Program PARABOL is written in such a way that it requires the following steps in GFTOUT. First the nodes have to be sorted in sequential order according to their numbering. This is done with the command SORT/POINT/1. Then these need to be written to the ASCII file together with the global coordinates of the points, command PW/NU,XC,YC,ZC/5,-2,10,-2,10,-2, 10/ where the string of numbers formats the output. Finally, the deformations are written to the file with the command DNSW/NU,XD,YD,ZD/5,-2,10,-2,10,-2,10/. All these data are written in the same file name JOBNAME.OUT, where JOBNAME is the name of the model and job one is working on.

This file may need some editing (e.g. with WordStar). As mentioned above the file contains first the coordinates of the points in sequential order followed by the deflections. Now, GFTOUT has the feature that it lists all the points, but it only lists the deflections of those points that are not suppressed in LOADBC. For PARABOL to work the coordinates of the these points have to be deleted. This is easy, just look at the deflections and note which are missing and then delete these in the coordinate listing.

The program is run by typing PARABOL. The first time it is used on a job one has to chose the options NEW JOB and NEW AREAS.

For PARABOL it's also important that the nodes at the dish surface are numbered in a certain way, see Figure 2. The first rib in the dish should be numbered in the 100's, 101,102,103,... and then the following rib 200 and so on. This is needed because in PARABOL one needs to know which nodes are on the surface. Suppose the model contains 25 ribs and that points 101,201,...,2501 are on the surface and so on for all points up to 110,210,...,2510. Then this is specified in PARABOL with the boundaries 1,10 and maximum point 2600. These numbers are asked for when the program is run. PARABOL then ignores all points less than 100 or greater than 2600 and only takes into account those that end with 01,...,10. The program can handle the two first loading cases. These are written into the files JOBNMAME.DF1 and JOBNAME.DF2. The selected coordinates are written into JOBNAME.COR

The program also asks for the last point number in the listing of the

points and the focal length of the undeformed dish. The program then asks for the areas at the nodes that are of interest. These have to be calculated in advance, and weighted with the illumination over the dish, i.e. how the receiver responds to the different parts of the dish surface. This information is written into file JOBNAME.DAT .

At a later time, if one saves the above files, it's possible to run PARABOL and use option OLD JOB, then one doesn't have to enter all this information again.

The program is then ready to calculate the best fit paraboloid. This is done by minimizing the integrated square of the surface error over the dish. The parameters that are optimized are: focal length, vertex position and rotation about the x and y-axis. The original paraboloid is assumed to have its focus on the z-axis and the vertex in the origin. There is the possibility suppressing some of these parameters. Suppose the model is half a dish, see Figure 4., using the symmetry in the calculations of the deflections with the part that has negative y-coordinates cut away, and the deflections as a result of forces parallel to the xz-plane. Then one doesn't expect the vertex to move in the y-coordinate and any rotation around the x-axis, these two parameters have to be set to zero. In addition to the calculation of the best fit paraboloid the surface rms error is also calculated and presented. The two different load cases can be combined to yield the deflections at different elevations, and thus the corresponding best fit paraboloid.

The other calculation the program can do is to calculate the change in average pathlength to the receiver compared to the undeformed dish. This is also called time delay in the program and is calculated by dividing the change in path length with the speed of light (metric units used, $c = 3 \cdot 10^8 m/s$). The deflected position of the receiver has to be entered. Again the load cases can be combined. The change is presented in two different ways of calculation: linearized and "exact". They usually differ in the third digit.

7 Program WINDLOAD

The program windload calculates forces due to wind. It uses results from wind tunnel tests performed at JPL (Ref. 4.). These tests have resulted

in pressure coefficients over the antenna dish for different elevations of the dish. These pressure coefficients are in files WINDXXX.PRS where XXX is the elevation in degrees. Appendix C contains a list of this program; Appendix D contains the coefficient files and a listing of a run with this program. The program is installed in the same directory as GIFTS and PARABOL. WINDLOAD.EXE is the executable file and WINDLOAD.BAS contains the code.

The program assumes half a dish oriented as in Figure 4., note the coordinate system in the lower left corner. To run this program one again has to use GFTOUT; this time it's sufficient to list only the coordinates of the nodes in a sorted sequence. The commands are SORT/POINT/1/ and PW/NU,XC,YC,ZC/5,-2,10,-2,10,-2,10/. One has to select one of the above files and also, as in program PARABOL, select the nodes at the surface. The program needs the air density, the wind speed and the areas at the selected nodes. The program calculates the wind forces (normal to the surface) at the nodes and writes them to file WINDLOAD.SRC. This file can then be used in LOADBC together with the OLB command to apply the wind loads to the structure.

The program uses the following formula to calculate the wind pressure p :

$$p = C \frac{\rho}{2} v^2 \quad (2)$$

where C is the pressure coefficient (depends upon the surface position of the node), v the wind speed and ρ the air density. The pressure coefficients are interpolated from the values in the files and the coordinates of its position. It's thus important that one has used a consistent set of units.

The program only calculates the forces on the dish surface. The loads on the backup structure or the different beams are not taken into account. Neither is the influence of these on the wind flow taken into account. The coefficient from the wind tunnel measurement are for a dish with no backup structure and $f/D = 0.33$. The antenna at Fairbanks has a large backup structure and $f/D = 0.42$. Thus the calculated forces are rather approximate in this case.

References

- [1] CASA/GIFTS Inc. *Users Reference Manual* 7474 Greenway Center Drive, Greenbelt, MD 20770
- [2] Katow M. S. and Smele L. W. *Antenna Structures: Evaluation Techniques of Reflector Distortions*. Supporting Research and Advanced Development Space Programs Summary 37-40, Vol. IV, p. 176. JPL Laboratory. Pasadena, Calif., August 31, 1966.
- [3] Katow M. S. *Antenna Structures: Evaluation of Reflector Surface Distortions* JPL Technical Report 32-1526, VOL. 1, p. 76. JPL Laboratory, Pasadena, Calif.
- [4] Fox N. L. *Load Distribution on the Surface of Paraboloidal Reflector Antennas* Aerodynamics Facilities, Sec 373, Internal Memorandum CP-4, JPL, Pasadena, Calif., July 1962.

8 APPENDIX A: Listing of program PARABOL

```
1000 OPTION BASE 1
1010 DIM A$(6,6),B$(6),AR$(100): FOR M=1 TO 100: AR$(M)=1#: NEXT M
1020 DIM R$(100),N$(100),A(100),B(100),NCO(100)
1030 CLS:PRINT:PRINT "=====
1040             PRINT "                      PROGRAM PARABOL"
1050             PRINT "          FITS A PARABOLOID TO A DEFORMED DISH"
1060             PRINT "          OR CALCULATES AVRERAGE TIME DELAY TO RECEIVER"
1070             PRINT "=====
1080             PRINT "                      NEW JOB:      1"
1090             PRINT "                      OLD JOB:      2"
1100             PRINT "                      NEW AREAS:    3"
1110             PRINT "                      FIT A PARABOLOID: 4"
1120             PRINT "                      AVERAGE TIME DELAY: 5"
1130             PRINT "                      END:          6"
1140             PRINT "-----"
1150 INPUT R
1160 IF R<1 OR R>6 THEN GOTO 1150
1170 ON R GOSUB 1400,1980,2220,2360,3890,1210
1180 '
1190 '
1200 '
1210 'Subroutine updates JOBNAME.par and ends program
1220 OPEN JN$+".PAR" FOR OUTPUT AS 5
1230 PRINT #5,F#
1240 PRINT #5,D
1250 FOR I=1 TO D
1260     PRINT #5,A(I),B(I)
1270 NEXT I
1280 PRINT #5,MAX
1290 PRINT #5,MP
1300 FOR I=1 TO D
1310     FOR J=A(I) TO B(I)
1320         PRINT #5,AR$(J)
1330     NEXT J
1340 NEXT I
1350 CLOSE #5
1360 END
1370 '
1380 '
1390 '
1400 'Subroutine edits JOBNAME.out from GIFTS
1410 CLS:PRINT:PRINT "=====
1420             PRINT "                      NEW JOB"
1430             PRINT "=====
1440             PRINT "          NAME OF GIFTS JOB": INPUT JN$
1450             PRINT "=====
1460             PRINT "          ORIGINAL FOCAL LENGTH":INPUT F#
1470             PRINT "=====
1480             PRINT "          BOUNDARIES FOR NODAL POINTS      MIN,MAX      (0,0=S
1490 I=0
1500 I=I+1:INPUT A(I),B(I)
1510 IF A(I)=0 AND B(I)=0 THEN I=I-1 : GOTO 1540
1520 IF A(I)<0 OR B(I)<0 OR A(I)>B(I) THEN I=I-1:PRINT "TRY AGAIN"
1530 GOTO 1500
1540             PRINT "          AND LESS THAN":INPUT MAX
```

```

1550          PRINT "-----"
1560          PRINT "  MAXIMUM NUMBER FOR NODAL POINT":INPUT MP
1570 D=I
1580          PRINT "-----"
1590 OPEN JN$+".OUT" FOR INPUT AS 1
1600 OPEN JN$+".COR" FOR OUTPUT AS 2
1610 OPEN JN$+".DF1" FOR OUTPUT AS 3
1620 OPEN JN$+".DF2" FOR OUTPUT AS 4
1630 'reading coordinates
1640 INPUT #1,NU,X#,Y#,Z#
1650 NUR=NU-100*INT(NU/100)
1660 FOR J=1 TO I
1670   IF NU<100 OR NUR<A(J) OR NUR>B(J) OR NU>MAX THEN GOTO 1690
1680   PRINT #2,NU,X#,Y#,Z#
1690 NEXT J
1700 IF NU=MP THEN GOTO 1720
1710 GOTO 1640
1720 CLOSE #2
1730 INPUT #1,Q$:INPUT #1,Q$:INPUT #1,Q$
1740 K=0
1750 INPUT #1,NU,DX#,DY#,DZ#
1760 NUR=NU-100*INT(NU/100)
1770 FOR J=1 TO I
1780   IF NU<100 OR NUR<A(J) OR NUR>B(J) OR NU>MAX THEN GOTO 1800
1790   PRINT #3,NU,DX#,DY#,DZ#
1800 NEXT J
1810 IF NU=MP THEN GOTO 1830
1820 GOTO 1750
1830 INPUT #1,Q$:INPUT #1,Q$
1840 K=0
1850 INPUT #1,NU,DX#,DY#,DZ#
1860 NUR=NU-100*INT(NU/100)
1870 FOR J=1 TO I
1880   IF NU<100 OR NUR<A(J) OR NUR>B(J) OR NU>MAX THEN GOTO 1900
1890   PRINT #4,NU,DX#,DY#,DZ#
1900 NEXT J
1910 IF NU=MP THEN GOTO 1930
1920 GOTO 1850
1930 CLOSE #1,#3,#4
1940 FOR M=1 TO 20000: NEXT M: RETURN 1030
1950 '
1960 '
1970 '
1980 'Subroutine reads parameters from JOBNAME.par
1990 CLS:PRINT:PRINT "-----"
2000          PRINT "                                OLD JOB"
2010          PRINT "-----"
2020          PRINT "  NAME OF OLD JOB": INPUT JN$
2030          PRINT "-----"
2040 OPEN JN$+".PAR" FOR INPUT AS 5
2050 INPUT #5,F#
2060 INPUT #5,D
2070 FOR I=1 TO D
2080   INPUT #5,A(I),B(I)
2090 NEXT I

```

```

2100 INPUT #5,MAX
2110 INPUT #5,MP
2120 FOR I=1 TO D
2130     FOR J=A(I) TO B(I)
2140         INPUT #5,AR#(J)
2150     NEXT J
2160 NEXT I
2170 CLOSE #5
2180 FOR M= 1 TO 20000: NEXT M:RETURN 1030
2190 '
2200 '
2210 '
2220 'Subroutine reads areas
2230     CLS:PRINT "=====
2240         PRINT "                      NEW AREAS"
2250     PRINT "=====
2260 FOR J=1 TO D
2270     FOR K=A(J) TO B(J)
2280         PRINT "  NODE",K: INPUT AR#(K)
2290     NEXT K
2300 NEXT J
2310     PRINT "-----
2320 FOR M=1 TO 20000: NEXT M: RETURN 1030
2330 '
2340 '
2350 '
2360 'Subroutine fits paraboloid to deformed dish
2370     CLS:PRINT "=====
2380         PRINT "                      LEAST SQUARE FIT"
2390     PRINT "=====
2400         PRINT "  CASE TITLE":INPUT T$
2410     PRINT "-----
2420         PRINT "  COMPOSITE LOAD    A*(LDCASE 1) + B*(LDCASE 2)
2430 INPUT AL#,BE#
2440     PRINT "-----
2450         PRINT "  PARAMETERS TO BE CONSTRAINED    (YES/NO)  1/0  "
2460         PRINT "  X0,Y0,Z0 ":INPUT NCO(1),NCO(2),NCO(3)
2470         PRINT "  ROTATION ABOUT X AND Y-AXIS":INPUT NCO(5),NCO(6)
2480         PRINT "  FOCAL LENGTH":INPUT NCO(4)
2490     PRINT "-----
2500 'zeroing A#(6,6) and B#(6)
2510 FOR I=1 TO 6
2520     B#(I)=0#
2530     FOR J= 1 TO 6
2540         A#(I,J)=0#
2550     NEXT J
2560 NEXT I
2570 'reading files
2580 OPEN JN$+".COR" FOR INPUT AS 1
2590 OPEN JN$+".DF1" FOR INPUT AS 2: OPEN JN$+".DF2" FOR INPUT AS 3
2600 IF EOF(1) THEN CLOSE: GOTO 2860
2610 INPUT #1,NP,X#,Y#,Z#: NPR=NP-100*INT(NP/100)
2620 INPUT #2,MP,U1#,V1#,W1#: INPUT #3,OP,U2#,V2#,W2#
2630 'compute partials and gradient
2640 U#=-AL#*U1#+BE#*U2#:V#=-AL#*V1#+BE#*V2#:W#=-AL#*W1#+BE#*W2#

```

```

2650 Z#=(X#*X#+Y#*Y#)/(4#*F#)
2660 T#=SQR(X#*X#+Y#*Y#+4#*F#*F#)
2670 R#(1)=-X#/T#
2680 R#(2)=-Y#/T#
2690 R#(3)=2#*F#/T#
2700 WT#=AR#(NPR)*R#(3)*R#(3)
2710 R#(4)=R#(3)*Z#
2720 R#(5)=Y#*R#(3)-Z#*R#(2)
2730 R#(6)=Z#*R#(1)-X#*R#(3)
2740 'computing matrix A and vector B
2750 FOR I=1 TO 6
2760     FOR J=1 TO 6
2770         A#(I,J)=A#(I,J)+WT#*R#(I)*R#(J)
2780     NEXT J
2790 NEXT I
2800 WT#=WT#*(R#(1)*U#+R#(2)*V#+R#(3)*W#)
2810 FOR I=1 TO 6
2820     B#(I)=B#(I)+WT#*R#(I)
2830 NEXT I
2840 GOTO 2600
2850 'constraining equations
2860 FOR J=1 TO 6
2870     IF NCO(J)=0 THEN GOTO 2920
2880     FOR L=1 TO 6
2890         A#(J,L)=0#: A#(L,J)=0#: A#(J,J)=1#
2900         B#(J)=0#
2910     NEXT L
2920 NEXT J
2930 'solve A(6,6)X(6)=B(6); X put in B
2940 SING#=.00001
2950 RMIN#=1.00001
2960 FOR I=2 TO 6
2970     IF A#(I,I)=0# THEN PRINT "MATRIX SINGULAR": PRINT "-----"
2980     ASAVE#=A#(I,I)
2990     M=I-1
3000     FOR L=1 TO M
3010         C#=A#(L,I)/A#(L,L)
3020         FOR J=I TO 6
3030             A#(I,J)=A#(I,J)-C#*A#(L,J)
3040         NEXT J
3050     NEXT L
3060     RATIO#=A#(I,I)/ASAVE#
3070     IF RATIO#<SING# THEN RMIN#=RATIO#
3080     FOR J=I TO 6
3090         A#(J,I-1)=A#(I-1,J)/A#(I-1,I-1)
3100     NEXT J
3110 NEXT I
3120 IF RMIN#<SING# THEN PRINT "MATRIX SINGULAR": PRINT "-----"
3130 'forward substitution
3140 FOR I=2 TO 6
3150     M=I-1
3160     FOR J=1 TO M
3170         B#(I)=B#(I)-A#(I,J)*B#(J)
3180     NEXT J
3190 NEXT I

```

```

3200 'backward substitution
3210 B#(6)=B#(6)/A#(6,6)
3220 FOR I=5 TO 1 STEP -1
3230     SUM#=0#
3240     M=I+1
3250     FOR J=M TO 6
3260         SUM#=SUM#+A#(I,J)*B#(J)
3270     NEXT J
3280     B#(I)=(B#(I)-SUM#)/A#(I,I)
3290 NEXT I
3300 B1=B#(1):B2=B#(2):B3=B#(3):B4=B#(4):B5=B#(5):B6=B#(6):F=F#
3310 '
3320 'computation of rms errors
3330 RMS#=0: ATOT#=0#
3340 OPEN JN$+".COR" FOR INPUT AS 1
3350 OPEN JN$+".DF1" FOR INPUT AS 2: OPEN JN$+".DF2" FOR INPUT AS 3
3360 IF EOF(1) THEN CLOSE:GOTO 3670
3370 INPUT #1,NP,X#,Y#,Z#: NPR=NP-100*INT(NP/100)
3380 INPUT #2,MP,U1#,V1#,W1#: INPUT #3,OP,U2#,V2#,W2#
3390 U#=AL#*U1#+BE#*U2#: V#=AL#*V1#+BE#*V2#: W#=AL#*W1#+BE#*W2#
3400 'compute normal errors
3410 FF#=F#/(1#+B#(4)): Z#=(X#*X#+Y#*Y#)/(4#*F#)
3420 T#=SQR(X#*X#+Y#*Y#+4#*FF#*FF#)
3430 D1#=-X#/T#
3440 D2#=-Y#/T#
3450 D3#=2#*FF#/T#
3460 CX1#=-D1#*B#(1)
3470 CY2#=-D2#*B#(2)
3480 CZ3#=-D3#*B#(3)
3490 CFOC#=-B#(4)*D3#*Z#
3500 TT#=SQR(X#*X#+Y#*Y#+4#*F#*F#)
3510 DD1#=-X#/TT#
3520 DD2#=-Y#/TT#
3530 DD3#=2#*F#/TT#
3540 CXX#=B#(6)*Z#
3550 CX#=D1#*(U#-CXX#)+DD1#*CXX#
3560 CYY#=-B#(5)*Z#
3570 CY#=D2#*(V#-CYY#)+DD2#*CYY#
3580 CZZ#=B#(5)*Y#+B#(6)*X#
3590 CZ#=D3#*(W#+CZZ#)+DD3#*CZZ#
3600 CXR#=B#(5)*(Z#+DD2#-Y#+DD3#)
3610 CYR#=B#(6)*(X#+DD3#+Z#+DD1#)
3620 'G# total normal error at each node
3630 G#=CX#+CY#+CZ#+CFOC#+CXR#+CYR#+CX1#+CY2#+CZ3#
3640 H#=G#*D3#
3650 RMS#=RMS#+AR#(NPR)*H#*H#: ATOT#=ATOT#+AR#(NPR)
3660 GOTO 3360
3670 RMS=SQR(RMS#/ATOT#): ATOT=ATOT#
3680 'presentation of results
3690 CLS:PRINT:PRINT "=====
3700     PRINT " RESULTS OF " T$
3710     PRINT "=====
3720     PRINT " VERTEX COORDINATES X0:",B1
3730     PRINT " YO:",B2
3740     PRINT " ZO:",B3

```

```

3750 PRINT "-----"
3760 PRINT " ROTATION ABOUT X-AXIS:",B5
3770 PRINT " Y-AXIS:",B6
3780 PRINT "-----"
3790 PRINT " NEW FOCAL LENGTH:",F/(1+B4)
3800 PRINT " CHANGE:",-F*B4/(1+B4)
3810 PRINT "-----"
3820 PRINT " RMS ERROR:",2*RMS
3830 PRINT " TOTAL AREA:",ATOT
3840 PRINT "-----"
3850 RETURN 1080
3860 '
3870 '
3880 '
3890 'Subroutine computes average time delay change
3900 CLS:PRINT "=====
3910 PRINT " COMPUTATION OF AVERAGE TIME DELAY"
3920 PRINT "-----"
3930 PRINT " CASE TITLE":INPUT T$
3940 PRINT "-----"
3950 PRINT " DEFORMATION OF FEED SUPPORT"
3960 PRINT " CHANGE IN RECIEVER POINT DX,DY,DZ": INPUT FX#
3970 PRINT "-----"
3980 PRINT " DEFORMATION OF DISH"
3990 PRINT " COMPOSITE LOAD A*(LDCASE 1) + B*(LDCASE 2)
4000 INPUT AL#,BE#
4010 PRINT "-----"
4020 TFL#=0#:TLL#=0#:ATOT#=0#
4030 'reading files
4040 OPEN JN$+".COR" FOR INPUT AS 1
4050 OPEN JN$+".DF1" FOR INPUT AS 2: OPEN JN$+".DF2" FOR INPUT AS 3
4060 IF EOF(1) THEN CLOSE: GOTO 4290
4070 INPUT #1,NP,X#,Y#,Z#: NPR=NP-100*INT(NP/100)
4080 INPUT #2,MP,U1#,V1#,W1#: INPUT #3,OP,U2#,V2#,W2#
4090 'compute partials and gradient
4100 U#=AL#*U1#+BE#*U2#:V#=AL#*V1#+BE#*V2#:W#=AL#*W1#+BE#*W2#
4110 Z#=(X#*X#+Y#*Y#)/(4#*F#)
4120 T#=SQR(X#*X#+Y#*Y#+(F#-Z#)*(F#-Z#))
4130 N#(1)=-X#/T#
4140 N#(2)=-Y#/T#
4150 N#(3)=(F#-Z#)/T#
4160 'full computation
4170 FL#=-W#-Z#+((X#+U#)*(X#+U#)+(Y#+V#)*(Y#+V#))/(4#*F#)
4180 XF#=(F#+Z#)*N#(1)-U#+FX#
4190 YF#=(F#+Z#)*N#(2)-V#+FY#
4200 ZF#=(F#+Z#)*N#(3)-W#+FZ#
4210 FL#=AR#(NPR)*(FL#+SQR(XF#*XF#+YF#*YF#+ZF#*ZF#)-F#-Z#)
4220 TFL#=TFL#+FL#
4230 'linearized computation
4240 LL#=-W#+(2#*X#*U#+2#*Y#*V#)/(4#*F#)
4250 LL#=AR#(NPR)*(LL#+N#(1)*(-U#+FX#)+N#(2)*(-V#+FY#)+N#(3)*(-W#+FZ#))
4260 TLL#=TLL#+LL#
4270 ATOT#=ATOT#+AR#(NPR)
4280 GOTO 4060
4290 FL=TFL#/ATOT#:LL=TLL#/ATOT#:ATOT=ATOT#

```

```

4300 'presentation of results
4310 CLS:PRINT:PRINT "-----"
4320 PRINT " RESULTS OF " T$
4330 PRINT "-----"
4340 PRINT " FULL CALCULATION OF CHANGE"
4350 PRINT " PATH LENGTH:",FL
4360 PRINT " TIME DELAY:",FL/3E+08
4370 PRINT "-----"
4380 PRINT " LINEARIZED CALCULATION OF CHANGE"
4390 PRINT " PATH LENGTH:",LL
4400 PRINT " TIME DELAY:",LL/3E+08
4410 PRINT "-----"
4420 PRINT " TOTAL AREA:",ATOT
4430 PRINT "-----"
4440 RETURN 1080

```

9 APPENDIX B: A full run of PARABOL

```
D:\GIFTS\JOBS>GFTOUT
GFTOUT  VER. 6.2.2
```

```
TYPE JOB NAME:  STOR
```

```
* SORT/POINT/1/
* FW/NU, XC, YC, ZC/5, -2, 10, -2, 10, -2, 10/
* DNSW/NU, XD, YD, ZD/5, -2, 10, -2, 10, -2, 10/
*
```

Comment. Run GFTOUT and write coordinates and deflections to file STOR.OUT. Exit with QUIT and then run PARABOL.

```
=====
                    PROGRAM PARABOL
          FITS A PARABOLOID TO A DEFORMED DISH
          OR CALCULATES AVERAGE TIME DELAY TO RECEIVER
=====
          NEW JOB:   1
          OLD JOB:   2
          NEW AREAS: 3
          FIT A PARABOLOID: 4
          AVERAGE TIME DELAY: 5
          END:       6
=====
? 1
```

Comment. Select NEW JOB by entering 1.

```

=====
                          NEW JOB
=====
NAME OF GIFTS JOB
? STOR
-----
ORIGINAL FOCAL LENGTH
? 10.9728
-----
BOUNDARIES FOR NODAL POINTS      MIN,MAX      (0,0=STOP)
? 1,10
? 0,0
AND LESS THAN
? 2600
-----
MAXIMUM NUMBER FOR NODAL POINT
? 31301

```

Comment. Enter data about the dish and select nodes at the dish surface.

```

=====
                          PROGRAM PARABOL
FIT A PARABOLOID TO A DEFORMED DISH
OR CALCULATES AVREAGE TIME DELAY TO RECEIVER
=====
NEW JOB: 1
OLD JOB: 2
NEW AREAS: 3
FIT A PARABOLOID: 4
AVERAGE TIME DELAY: 5
END: 6
-----
? 3

```

Comment. Select NEW AREAS.

=====

NEW AREAS

=====

NODE	1
? .566	
NODE	2
? 1.067	
NODE	3
? 1.268	
NODE	4
? 1.454	
NODE	5
? .688	
NODE	6
? .706	
NODE	7
? .899	
NODE	8
? .945	
NODE	9
? .639	
NODE	10
? .159	

Comment. Enter areas (weighted with the illumination over the dish).
Then select FIT A PARABOLOID from the menu.

=====

LEAST SQUARE FIT

=====

CASE TITLE
? HORIZON

COMPOSITE LOAD $A*(LDCASE\ 1) + B*(LDCASE\ 2)$ A,B
? 1,-1

PARAMETERS TO BE CONSTRAINED (YES/NO) 1/0
X0,Y0,Z0
? 0,1,0
ROTATION ABOUT X AND Y-AXIS
? 1,0
FOCAL LENGTH
? 0

Comment. Select composite load and constraints.

```

=====
RESULTS OF HORIZON
=====
      VERTEX COORDINATES X0: -7.671075E-02
                          YO:  0
                          ZO:  1.490902E-03
-----
      ROTATION ABOUT X-AXIS:  0
                          Y-AXIS:  1.618997E-03
-----
      NEW FOCAL LENGTH:  10.96856
      CHANGE: -4.240478E-03
-----
      RMS ERROR:  1.495526E-03
      TOTAL AREA:  150.018
-----
      NEW JOB:  1
      OLD JOB:  2
      NEW AREAS:  3
      FIT A PARABOLOID:  4
      AVERAGE TIME DELAY:  5
      END:  6
-----

```

? 5

Comment. The result of the calculation of the best fit paraboloid. Select AVERAGE TIME DELAY.

```

=====
      COMPUTATION OF AVERAGE TIME DELAY
=====
      CASE TITLE
? HORIZON
-----
      DEFORMATION OF FEED SUPPORT
      CHANGE IN RECIEVER POINT    DX,DY,DZ
? .01,0,0
-----
      DEFORMATION OF DISH
      COMPOSITE LOAD    A*(LDCASE 1) + B*(LDCASE 2)    A,B
? 1,-1

```

Comment. Enter the new position of the receiver and the composite load.

```

=====
RESULTS OF HORIZON
=====
FULL CALCULATION OF CHANGE
      PATH LENGTH: -3.628727E-03
      TIME DELAY: -1.209576E-11
-----
LINEARIZED CALCULATION OF CHANGE
      PATH LENGTH: -3.647771E-03
      TIME DELAY: -1.215924E-11
-----
TOTAL AREA: 150.018
-----
NEW JOB: 1
OLD JOB: 2
NEW AREAS: 3
FIT A PARABOLOID: 4
AVERAGE TIME DELAY: 5
END: 6
-----

```

? 6

Comment. The result of the calculation. Exit by entering 6.

10 APPENDIX C: Listing of program WINDLOAD

```

'Program WINDLOAD computes windforces on a parabola
,
'Description.
'Run GFTOUT on the job. Use: SORT/POINTS/1 and PW/NU,XC,YC,ZC/5,-2,10,..
'Run WINDLOAD.
'Program reads preasure coefficients from file <file name>.prs.
'This file should contain on the first line the number of radial data an
'the number of angular data.
'Thereafter should follow radius/diameter,angle and preasure coeffcient;
'lowest radius first with increasing angle.
'   Example:   2       2
'               0.1   15   1.31
'               0.1   45   1.41
'               0.3   15   1.35
'               0.3   45   1.42
'Program then interpolates the coefficients for the selected nodes.
'WINDLOAD.SRC contains the forces. In LOADBC OLB/WINDLOAD.
'End of description.
,
pi=3.14159265
dim pla(10,20),plr(10,20),cof(10,20),a(10),b(10),ar(99)
cls:print "=====
print "                PROGRAM WINDLOAD"
print "      computes windloads on a antenna dish"
print "=====
print " Name of preasure coefficient file ?": input wn$
print " Windspeed and air density ?": input v,ro
print "-----"
print " Name of GIFTS job ?": input jn$
print " Focal length and diameter of antenna": input foc,diam
print " Boundaries for nodal point      min,max      (0,0=stop)"
,
'Selecting nodes
i=0
100 i=i+1: input a(i),b(i)
    if a(i)=0 and b(i)=0 then i=i-1: d=i: goto 200
    if a(i)<0 or b(i)<0 or a(i)>b(i) then i=i-1: print "Try again"
    goto 100
200 print " And less than": input max
    print "-----"
,
'Reading areas
print " Area at"
for i=1 to d
    for j=a(i) to b(i)
        print " node",j: input ar(j)
    next j
next i
print "-----"
,
'Reading presure coefficients
open wn$+".prs" for input as 1
input #1,imax,jmax
for i=1 to imax
    for j= 1 to jmax

```

```

        input #1,plr(i,j),pla(i,j),cof(i,j)
    next j
next i
close
,
'Reading coordinates
open jn$+".out" for input as 1
open "windload.src" for output as 2
300 if eof(1) then print #2,"END":close: end
    input #1,nu,xc,yc,zc: nur=nu-100*int(nu/100)
    for i=1 to d
        if nu>max then print #2, "END": close: end
        if nu<100 or nur<a(i) or nur>b(i) then goto 400
        gosub force
400 next i
    goto 300
end
,
force:
'Subroutine calculates wind force at nodes
'Calculating gradient
    t=sqr(xc*xc+yc*yc+4*foc*foc)
    r1=xc/t
    r2=yc/t
    r3=-2*foc/t
    rad=sqr(xc*xc+yc*yc)/diam
    ang=90
    if xc>0 and abs(xc)>0.0001 then ang=180*(1-atn(yc/xc)/pi)
    if xc<0 and abs(xc)>0.0001 then ang=-180*atn(yc/xc)/pi
,
'Get interpolated coefficient
    gosub interpol
,
'Print forces to src file
    frc=ro*v*v/2*coff*ar(nur)
    print #2,"LOADP,1/",NU,"/",frc*r1,"/"
    print #2,"LOADP,2/",NU,"/",frc*r2,"/"
    print #2,"LOADP,3/",NU,"/",frc*r3,"/"
    return 300
,
interpol:
'Subroutine interpolates pressure coefficient
'Finding surrounding coordinates
    i=2
50 if plr(i,1)<rad or plr(i,1)=rad then i=i+1
    if i=imax or plr(i,1)>rad then goto 60
    goto 50
60 ih=i: il=ih-1
,
    j=2
70 if pla(ih,j)<ang or pla(ih,j)=ang then j=j+1
    if j=jmax or pla(ih,j)>ang then goto 80
    goto 70
80 jh=j: jl=jh-1
,

```

```

'Interpolation
  cl=(cof(ih,j1)-cof(il,j1))*(rad-plr(il,j1))
  cl=cl/(plr(ih,j1)-plr(il,j1))+cof(il,j1)
  ,
  ch=(cof(ih,jh)-cof(il,jh))*(rad-plr(il,jh))
  ch=ch/(plr(ih,jh)-plr(il,jh))+cof(il,jh)
  ,
  coff=cl+(ch-cl)*(ang-pla(il,j1))/(pla(il,jh)-pla(il,j1))
'Diagnostics section to be turned on
  print
  print nu,rad,ang
  print plr(ih,j1),plr(il,jh)
  print cof(ih,j1),cof(il,j1),pla(ih,j1)
  print cof(ih,jh),cof(il,jh),pla(ih,jh)
  print cl,ch,coff
  print frc*r1,frc*r2,frc*r3
  ,
  return

```

11 APPENDIX D: A full run of WINDLOAD

FILESPEC.EXT	BYTES	ATR	-LAST	CHANGE-
WIND000 .PRS	977		09/22/87	12:57
WIND060 .PRS	871		09/22/87	13:02
WIND090 .PRS	939		09/22/87	13:05
WIND120 .PRS	1056		09/22/87	13:28
WIND180 .PRS	985		09/22/87	13:32

Comment. The available files with pressure coefficients. WIND060.PRS contains the coefficients for the antenna at 060 degrees elevation.

```
=====
                        PROGRAM WINDLOAD
                        computes windloads on a antenna dish
=====
```

```
Name of preasure coefficient file ?
```

```
? wind090
```

```
Windspeed and air density ?
```

```
? 10,1.29
```

```
-----
Name of GIFTS job ?
```

```
? stor
```

```
Focal length and diameter of antenna
```

```
? 10.9728,26
```

```
Boundaries for nodal point      min,max      (0,0=stop)
```

```
? 1,10
```

```
? 0,0
```

```
And less than
```

```
? 2600
```

```
-----
Area at
node      1
? .5658
node      2
? 1.112
node      3
? 1.409
node      4
? 1.730
node      5
? .882
node      6
? 1.038
node      7
? 1.605
node      8
? 1.817
node      9
? 2.060
node     10
? 1.134
```

Comment. A full run of the program. The units used are metric. The forces are written to file WINDLOAD.SRC and can be used in processor LOADBC.

Part II

Path Length Changes in an Antenna

12 Introduction

This part contains some basic facts about how an antenna deforms. Section 14 identifies some important parameters that can be used to characterize the behaviour of the dish; Section 15 tries to characterize the behaviour of the antenna when it deforms due to gravity loads; and Section 16 studies the effects of temperature. In this report the *average path length* to the receiver is used to estimate the time delay experienced in the antenna; a more detailed analysis would use diffraction theory.

13 The paraboloid

The equation for a paraboloid in a cartesian coordinate system with the vertex at $(0, 0, 0)$ and the focus at $(0, 0, f)$ is

$$z = \frac{x^2 + y^2}{4f} \quad (13.1)$$

or if we put $x^2 + y^2 = r^2$

$$z = \frac{r^2}{4f} \quad (13.2)$$

In Figure 7 there is a reference plane through $(0, 0, a)$. If one traces a ray parallel to the z -axis from this plane and reflects it in the paraboloid, it passes through the focal point. What's more, the distance from the plane to the focal point is constant. The distance from A a point on the reference plane to P a point on the parabola is

$$a - \frac{r^2}{4f}$$

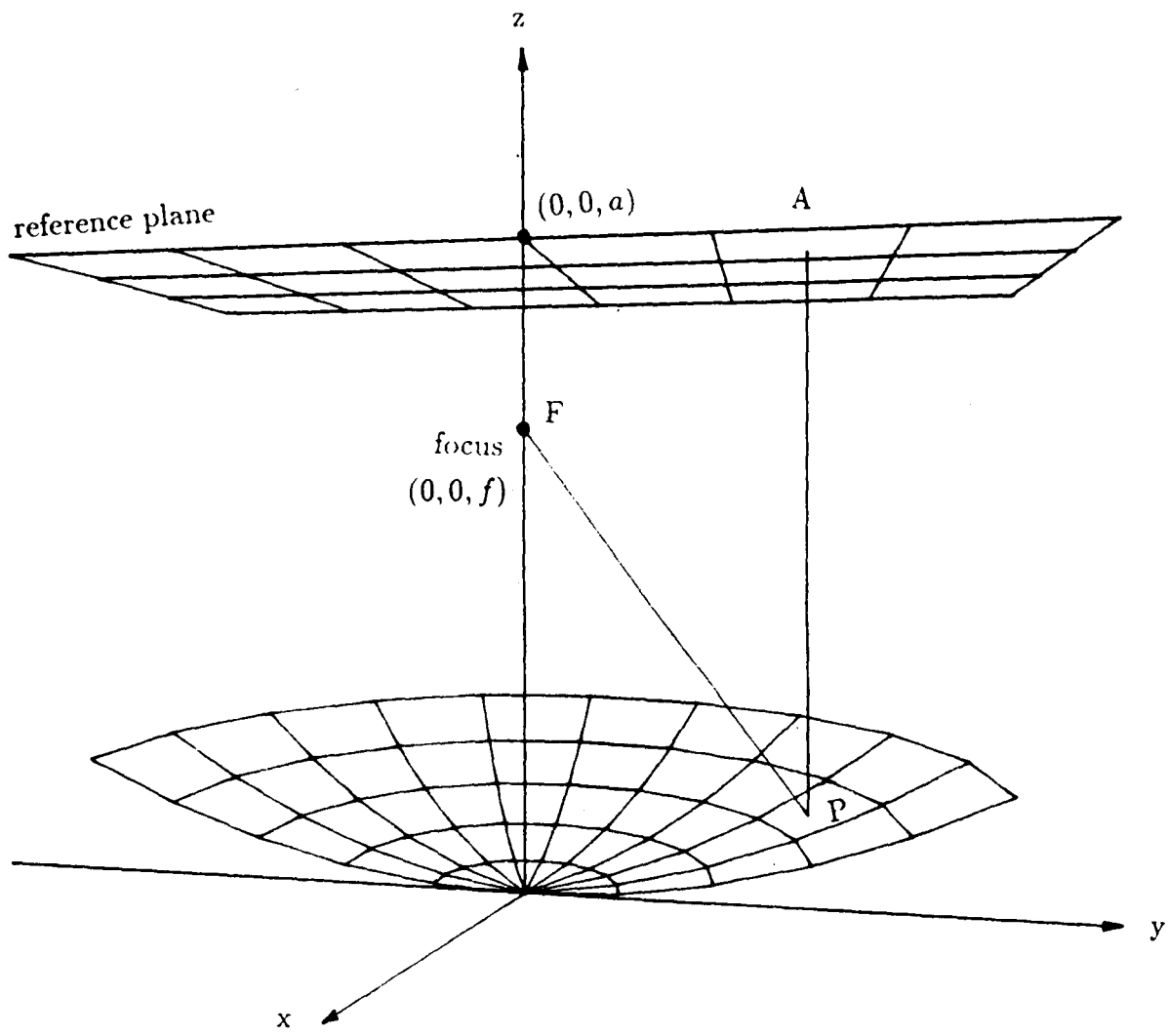

Figure 7: In the figure the paraboloid is cut along the y-axis. A ray is traced from the reference plane parallel to the z-axis and passes through the focus when reflected in the paraboloid. The equation for the paraboloid is $z = (x^2 + y^2)/4f$, where f is the focal length.

and the square of the distance from P to F is

$$r^2 + \left(f - \frac{r^2}{4f}\right)^2 = r^2 + f^2 + \frac{r^4}{16f^2} - \frac{r^2}{2} = \left(f + \frac{r^2}{4f}\right)^2$$

and thus the sum of these two distances is $a + f$, independent of r .

14 Changing the paraboloid

Now if the antenna deforms due to external forces the paraboloid changes shape, position and orientation. The receiver also changes position. Then the average path length to the receiver from the reference plane changes. See Ref. 1. Call this change ΔL . Let the change in focal length be Δf and the change in the position of the vertex in z -coordinate be ΔV . The changes in x and y -coordinates do not change the path length because they are parallel to the reference plane; assume these coordinates to be unchanged. Let the rotation about the x and y -axis be θ and ϕ and the change in the position of the receiver be ΔP , ΔQ and ΔR . Then ΔL is a function of these variables; call this function F .

$$\Delta L = F(\Delta f, \Delta V, \theta, \phi, \Delta P, \Delta Q, \Delta R)$$

The changes in the variables are small and $F(0, \dots, 0) = 0$ so to first order

$$\Delta L = F'_{\Delta f} \Delta f + F'_{\Delta V} \Delta V + F'_\theta \theta + F'_\phi \phi + F'_{\Delta P} \Delta P + F'_{\Delta Q} \Delta Q + F'_{\Delta R} \Delta R$$

where the partial derivatives are taken at $(0, \dots, 0)$. It's obvious that

$$F(0, 0, \theta, 0, 0, 0, 0) = F(0, 0, -\theta, 0, 0, 0, 0)$$

from the symmetry of the geometry. (The illumination over the dish is assumed to depend only on r .) Thus $F'_\theta = 0$ and in the same way $F'_\phi = 0$. The same argument also shows that $F'_{\Delta P} = 0$ and $F'_{\Delta Q} = 0$. Now put $F'_{\Delta f} = \alpha_f$, $F'_{\Delta V} = \alpha_V$ and $F'_{\Delta R} = \alpha_R$. Then we have

$$\Delta L = \alpha_f \Delta f + \alpha_V \Delta V + \alpha_R \Delta R \quad (14.1)$$

There exist, some simple relations between the different coefficients in this equation. For example, if the paraboloid is translated along the the z -axis

a distance d towards the reference plane and the receiver is moved to the new focus, then $\Delta L = -d$, $\Delta f = 0$, $\Delta V = d$ and $\Delta R = d$. From this one gets

$$\alpha_V + \alpha_R = -1 \quad (14.2)$$

If the paraboloid changes focal length $\Delta f = l$, the vertex is kept fixed $\Delta V = 0$ and the receiver is moved to the new focus $\Delta R = l$, then $\Delta L = l$. Now we get

$$\alpha_f + \alpha_R = 1 \quad (14.3)$$

14.1 Estimation of α_R

Ref 1. shows how to estimate changes in a Cassegrainian antenna. A similar technique is used below. According to Figure 1, the vector from P to F , call it \mathbf{PF} , is

$$\mathbf{PF} = \left(-x, -y, f - \frac{r^2}{4f}\right)$$

or if we normalize and call this vector \mathbf{n} and put $r/2f = t$ then

$$\mathbf{n} = \left(\frac{-x/f}{1+t^2}, \frac{-y/f}{1+t^2}, \frac{1-t^2}{1+t^2}\right)$$

From Figure 8, we see that the change in pathlength due to a change in the receiver position ΔR to first order is

$$\mathbf{n} \cdot \mathbf{e}_z \Delta R = \frac{1-t^2}{1+t^2} \Delta R$$

This is just the change for one ray and to get α_R we have to average $\mathbf{n} \cdot \mathbf{e}_z$ over the dish. We assume that the illumination over the dish only depends on the radial distance r (or t). Call this function I . The illumination usually has a maximum in the center and decreases towards the rim. If we normalize this function so that

$$\int_0^{r_0} I 2\pi r dr = 1$$

where r_0 is the radius of the dish, then the function can be used for averaging. To estimate α_R we choose the function to be constant: $I = 1/\pi r_0^2$.

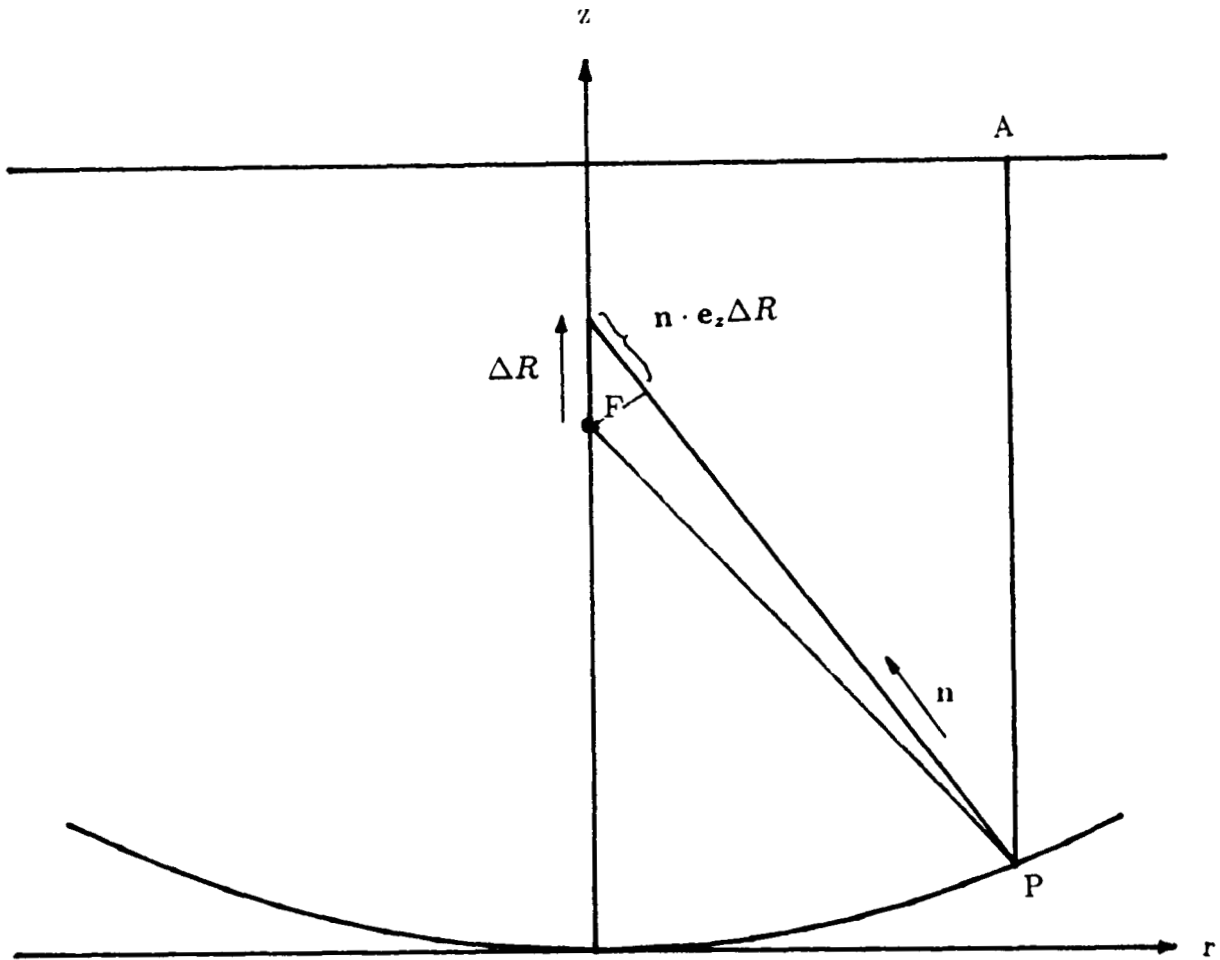

Figure 8: In the figure the receiver is moved along the z -axis a distance ΔR . This changes the path length, and one sees that this change is $\mathbf{n} \cdot \mathbf{e}_z \Delta R$, where \mathbf{n} is a unit vector along the reflected ray and \mathbf{e}_z is a unit vector along the z -axis.

Finally we get

$$\alpha_R = \int_0^{r_0} \frac{1-t^2}{1+t^2} I 2\pi r dr = \frac{4f^2}{r_0^2} \int_0^{t_0} \frac{1-t^2}{1+t^2} 2t dt$$

Evaluation of the integral yields

$$\alpha_R = \frac{2}{t_0^2} \ln(1+t_0^2) - 1 \quad (14.4)$$

where $t_0 = r_0/2f$. The parameter t_0 is easy to relate to an actual dish, because $t_0 = D/4f$ and f/D is well known parameter for all dishes. Eq. 14.4 is plotted in Figure 9.

A typical value, $f/D = 0.4$, yields $\alpha_R = 0.7$. Calculations on a computer for a more realistic illumination function with the illumination at the rim one tenth of the value at the center yields $\alpha_R = 0.8$. What happens is that the central part, which is more heavily illuminated and where the change is greater, has more influence. Using this value we can now use Eqs. 14.2-3 and get $\alpha_f = 0.2$ and $\alpha_V = -1.8$.

14.2 Deviations from a paraboloid

The discussion so far has assumed a perfect paraboloid. When a dish deforms due to external forces its shape will not be that of a paraboloid. We can however fit a paraboloid to the deformed dish in such a way that the rms error in path length to the best fit focus is minimum. See Ref. 2. Figure 10 defines this error δ . It is a function of x, y and some set of parameters \mathbf{q} that determines the change in the paraboloid to achieve the best fit. A choice of parameters is the change in focal length, the change in position of the vertex and the rotations about the x and y-axis. Thus we have

$$\delta = \delta(x, y; \mathbf{q})$$

The function $R(\mathbf{q}) = \int \delta^2(x, y; \mathbf{q}) I dx dy$, where I is the the illumination as before, is minimized to yield the values \mathbf{q}_0 for the best fit paraboloid. This means that $R'_{q_i} = 0$ for $\mathbf{q} = \mathbf{q}_0$. In the following let the partial derivatives be evaluated at this point. An important result is that

$$\int \delta(x, y; \mathbf{q}_0) I dx dy = 0 \quad (14.5)$$

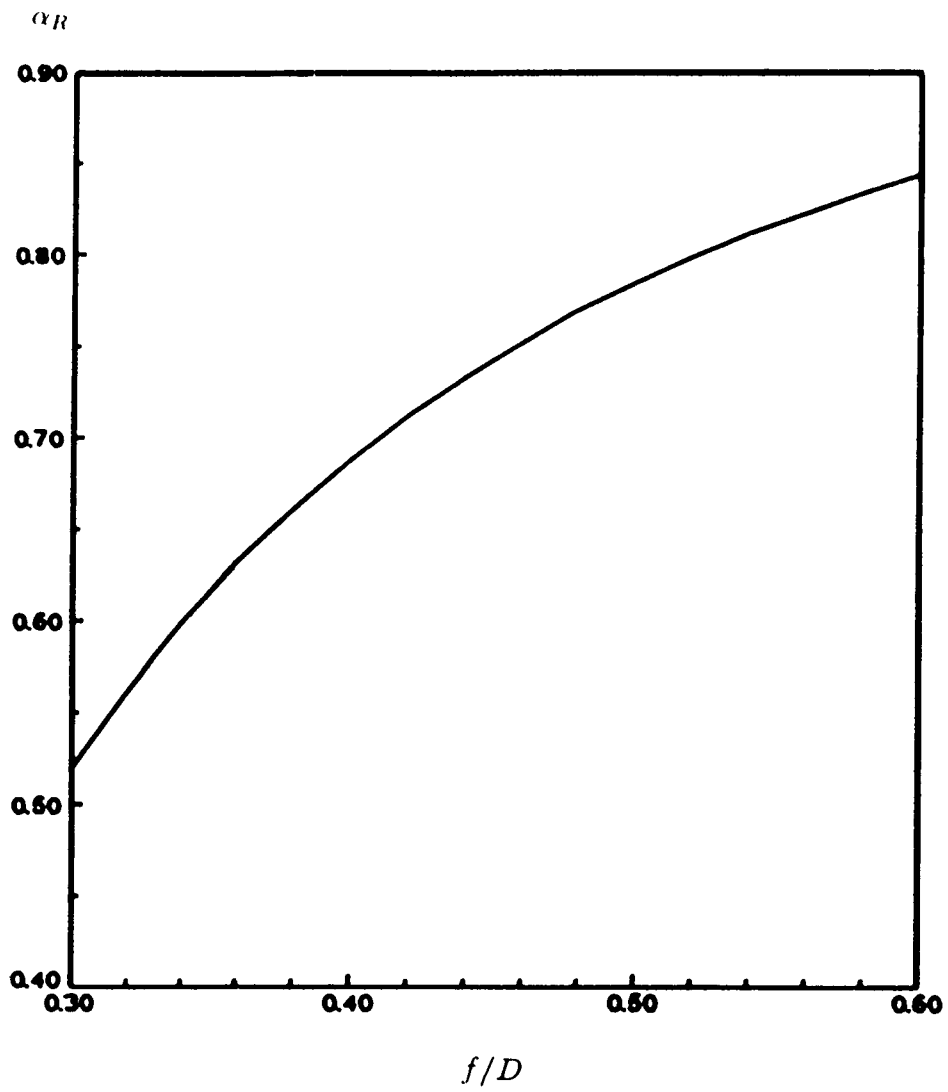

Figure 9: α_R as a function of f/D according to Eq. 14.4.

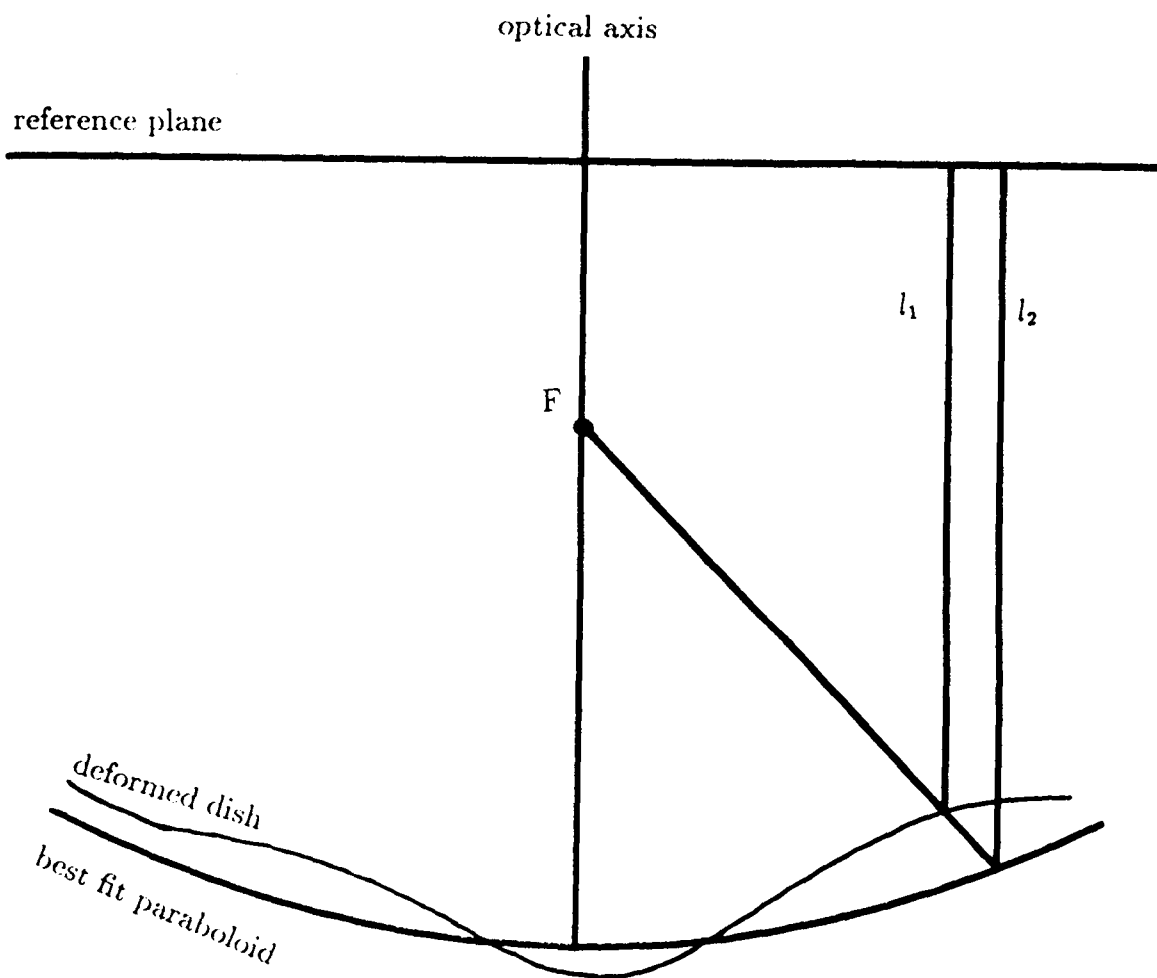

Figure 10: Definition of the error δ : $\delta = l_1 - l_2$. This error is minimized when calculating the best fit paraboloid. Both l_1 and l_2 run from the reference plane to the paraboloid and the deformed dish and finally to the focus. Note that the reference plane is orthogonal to the optical axis of the paraboloid one wishes to fit.

This means average path length to the best fit focus is the same for the deformed dish as for the best fit paraboloid. To see this, note that

$$R'_{q_i} = \int 2\delta'_{q_i} \delta I dx dy = 0$$

and then for a set of constants a_i

$$\sum a_i R'_{q_i} = \int 2(\sum a_i \delta'_{q_i}) \delta I dx dy = 0$$

Now if $\sum a_i \delta'_{q_i}$ is independent of x and y for some choice of a_i then Eq. 14.5 is true. From Figure 11 we have that

$$\delta(x, y; f_0, z_0) = l_1 - l_2$$

$$\delta(x, y; f_0 + \Delta f, z_0 - \Delta f) = l_1 - l_3$$

and this means that

$$\delta(x, y; f_0 + \Delta f, z_0 - \Delta f) - \delta(x, y; f_0, z_0) = l_2 - l_3 = -2\Delta f$$

and we then have $\delta'_f - \delta'_z = -2$, independent of x and y just as required.

But the receiver is not necessarily at the best fit focus. We have to study the difference in path length to the receiver between the deformed dish and the best fit paraboloid. (The difference to the best fit focus is as just shown zero). We assume as before that the deformations in the antenna are small. This means that the difference in position between the best fit focus and the receiver ΔR and the error from the best fit paraboloid Δd are small. See Figure 12. Then a simple calculation shows that the change in $l_1 - l_2$ is on the order of $\Delta d \Delta R / f$, where f again is the focal length. Here Δd and ΔR are much less than f and thus the error from the deformed dish is negligible compared to the changes calculated in Section 14. (on the same order as ΔR). Furthermore, this error should be averaged over the dish which will reduce it even further. As an example: with GIFTS and PARABOL, mentioned in Part I, typical calculated values for the Fairbanks antenna are $\Delta L \sim 10^{-2}m$, $\Delta R \sim 10^{-2}m$ and $\Delta d \sim 10^{-2}m$; for this antenna $f \sim 10m$; this yields an error of $10^{-5}m$ or 0.1 percent of the calculated change.

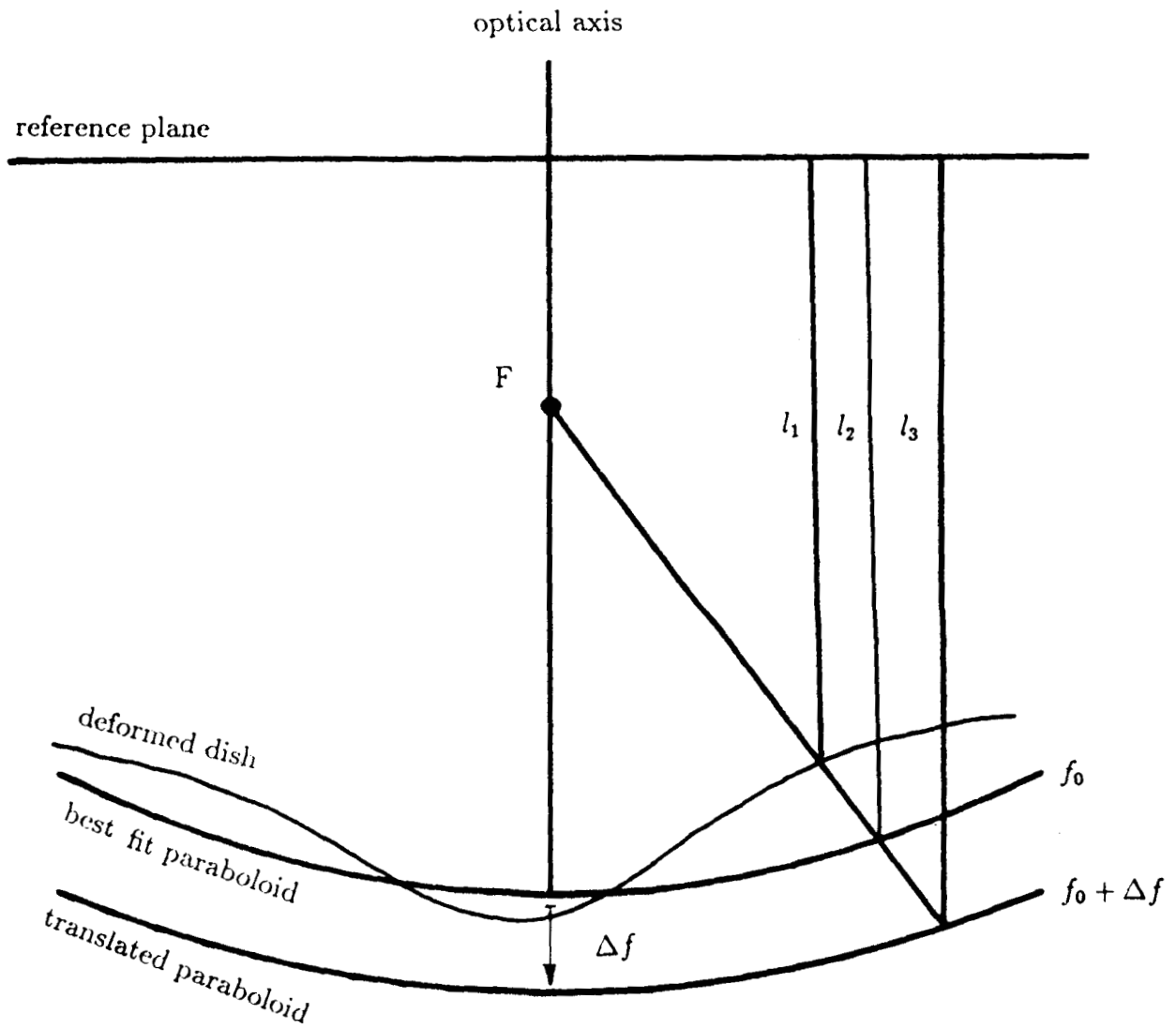

Figure 11: In the figure l_2 is reflected in the best fit paraboloid, and l_3 is reflected in a paraboloid with longer focal length but translated along the optical axis in such a way that l_3 also passes through the best fit focus.

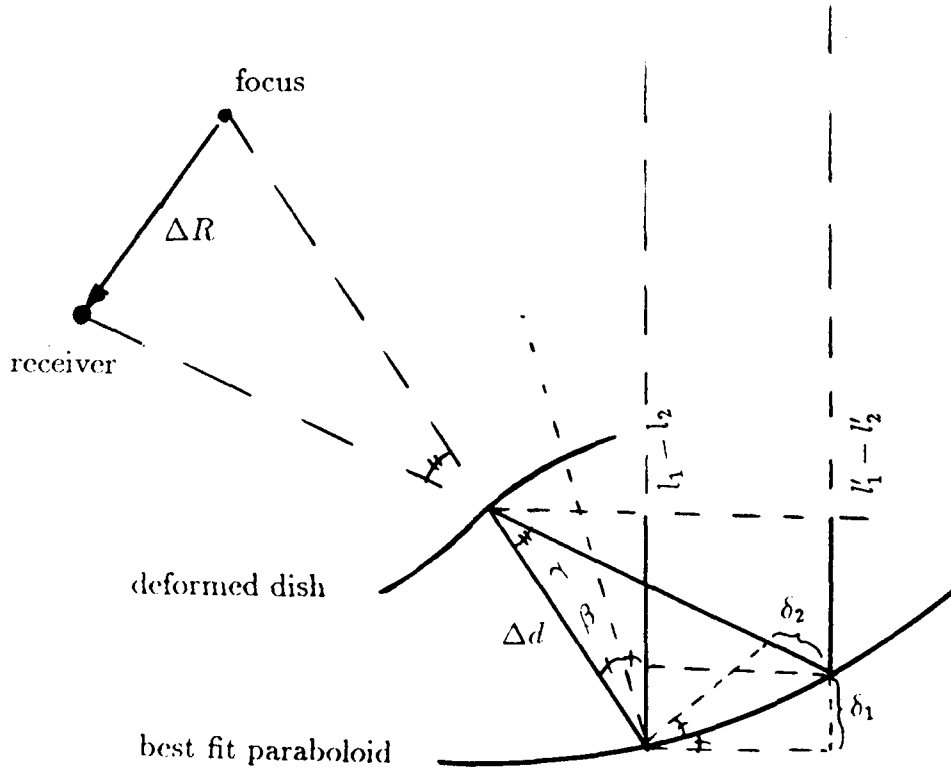

Figure 12: When the receiver is moved $l_1 - l_2$ changes. From the figure one sees that the change is $\delta_2 - \delta_1$. One also gets $\gamma \approx \Delta R/f$. Furthermore, $\delta_1 < \Delta d \tan \gamma \approx \Delta d \gamma \approx \Delta d \frac{\Delta R}{f}$ and $\delta_2 \approx \Delta d \tan \gamma \tan \beta \approx \Delta d \gamma \tan \beta$. By taking the derivative of Eq. 13.2 we get $\tan \beta = r/2f < 1$. To sum it up: the change is on the order of $\Delta d \Delta R/f$.

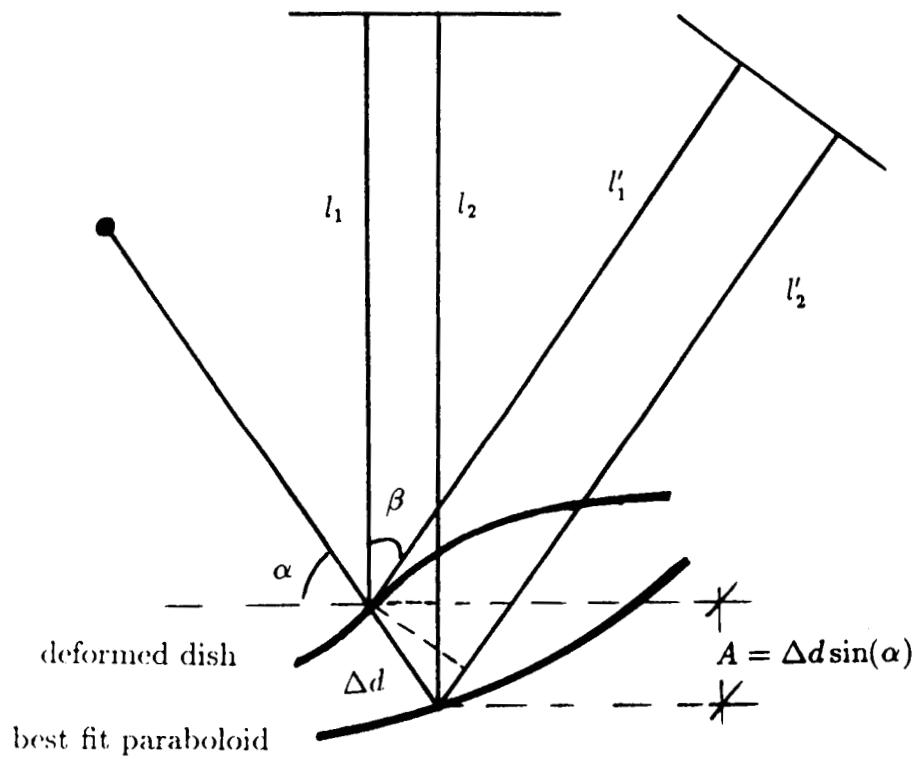

Figure 13: The incoming wave front - the reference plane - is not orthogonal to the optical axis. The angle is β . From the figure one sees that $A = \Delta d \sin(\alpha)$ and thus $\Delta A \approx \Delta d \cos(\alpha) \beta$.

Furthermore, the incoming wavefront does not have to be orthogonal with the optical axis. This error is illustrated in Figure 11. And the calculation yields an error on the order of $\Delta d \cos(\alpha)\beta$. A typical value for β is $10^{-2}rad$ and thus an error of $10^{-4}m$ or about 1 percent of the calculated change.

To sum it up: the changes in the average path length to the receiver when a dish deforms can be approximated with the change to the receiver from the best fit paraboloid. This change, to first order Eqs. 14.1-3, is much greater than the error made in the approximation.

15 Changes due to gravity

The deformations in an antenna due to gravity depend upon the position of the antenna. These deformations change the path length to the receiver. Numerical results will be given in Part III of this report; this section tries to motivate the behaviour of the change at different positions of the antenna. Again call the change in path length ΔL .

For an AZ-EL antenna ΔL by symmetry depends only on the elevation EL:

$$\Delta L = G(EL)$$

The function G can be expanded in a Fourier series

$$\Delta L = a_0 + a_1 \cos EL + b_1 \sin EL + \dots \quad (15.1)$$

where the sine and cosine terms are closely related to the components of the gravity vector shown in Figure 14. The component along the optical axis is proportional to $\sin EL$. This component also determines the deflection in this direction, and thus this term should dominate in the series.

For a X-Y mounted antenna:

$$\Delta L = H(X, Y)$$

with the obvious symmetries for H

$$H(X, Y) = H(-X, Y) = H(X, -Y) = H(-X, -Y)$$

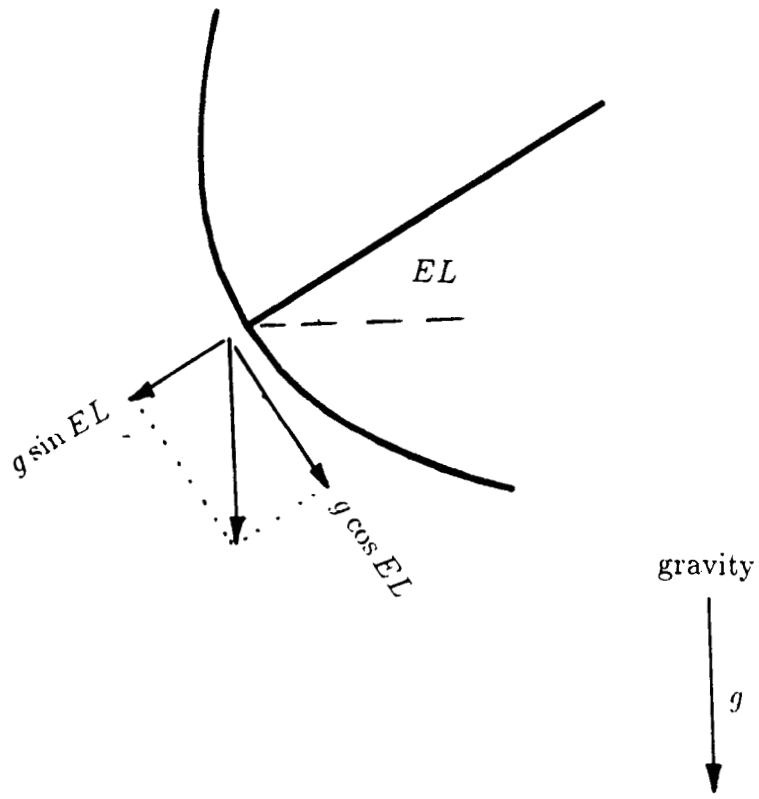

Figure 14: The components of the gravity vector. The forces along the optical axis are proportional to $\sin EL$.

Expanding this function into a two variable Fourier series and using the symmetries yields only terms with cosines

$$\Delta L = \sum_{n,m=0}^{\infty} a_{nm} \cos nX \cos mY$$

and if we write the first few terms

$$\Delta L = a_{00} + a_{10} \cos X + a_{01} \cos Y + a_{11} \cos X \cos Y + \dots \quad (15.2)$$

Here we note that $\cos X \cos Y = \sin EL$. See Ref. 3. The same argument can be used to show that ΔV , ΔR and ΔF (deformations along the optical axis defined in Sec. 14) should have the same type of expansion.

The same argument that was used to motivate the $\sin EL$ term in the AZ-EL antenna can be used again. However, the distance between the X- and Y-axis will also change. The component of the gravity vecto along this distance is proportional to $\cos X$, and then also the change in the distance D. See Figure 15. From the figure we see that the change in distance the wave front has to travel to the reference point is again proportional to $\cos X \cos Y$ or $\sin EL$. And again this term should dominate in the series.

16 Changes due to temperature

For a beam with original lenth l the change in length Δl due to a change in temperature ΔT is

$$\Delta l = \alpha \Delta T l \quad (16.1)$$

where α is the thermal expansion coefficient for the material in the beam.

Thus the parameters ΔV , Δf and ΔR also should be proportional to ΔT . The same is true for ΔD , the change in distance between x and y-axis. The first three gives rise to a change in path length through the antenna that is proportional to ΔT according to Eq. 14.1, and the last one to a change that is also proportional to $\cos Y$ according to Figure 15.

And thus the change in average path length through the antenna to the reference point should be

$$\Delta L = \Delta T(c_1 + c_2 \cos Y) \quad (16.2)$$

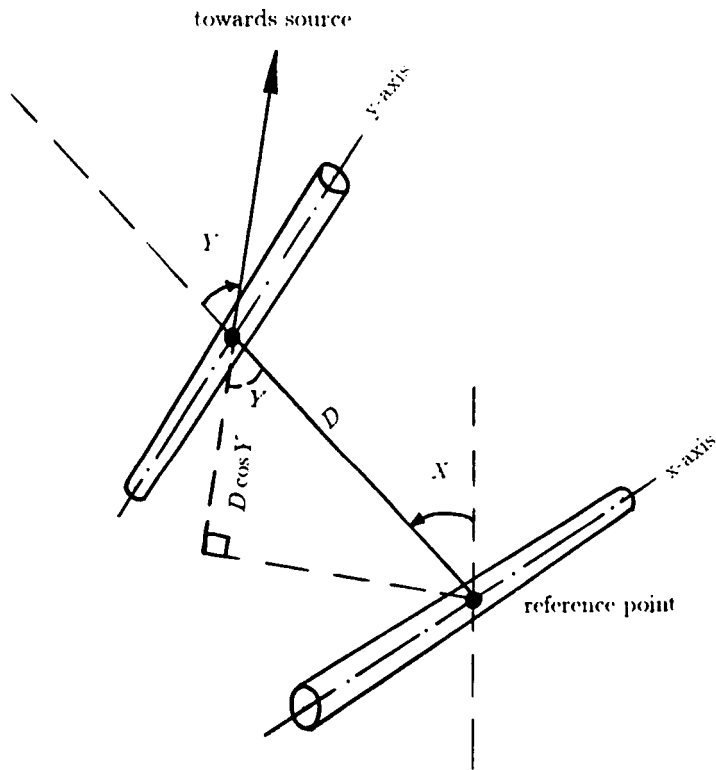

Figure 15: The geometry of the X-Y antenna. The distance between the two axes is D . The distance the incoming wavefront has to travel from the Y-axis to the reference point is $D \cos Y$.

where c_1 and c_2 are constants if we assume that ΔV , Δf , ΔR and ΔD are independent of X and Y . Calculations presented in Part III will confirm this.

References

- [1] Cha A. G. *Phase and frequency stability of Cassegrainian antennas* Radio Science, Vol. 22, Number 1, p. 156, 1987
- [2] Katow M. S. *Antenna Structures: Evaluation of Reflector Surface Distortions* JPL Technical Report 32-1562, VOL. 1, p. 76, JPL Laboratory, Pasadena, Calif.
- [3] Salzberg I. M. *Mathematical Relationships of the MFOD Antenna Axes* Goddard Space Flight Center (X-553-67-213), Greenbelt, Maryland, May 1967

Part III

The Antenna at Fairbanks, Alaska

17 Introduction

This part presents the numerical results, calculated deformations in the VLBI antenna at Fairbanks, Alaska. It also presents the results from measurements of these deformations as a comparison, and gives a presentation of the different models used and how the calculations were performed on these models.

Many of the ideas and calculations presented were prompted by my discussions with Dr. Lee King at NRAO in Socorro, New Mexico during my visit there. I am grateful for his help. The actual data on the antenna structure was collected during several visits to Bendix Field Engineering in Columbia and on a visit to the station in Alaska. During the latter visit several measurements were also made.

The focus of the part is on deformations that affect the accuracy of the VLBI experiments: the movement of the reference point is studied; the time delay through the antenna to the receiver is also studied. The latter was discussed in Part II of this report. The forces acting on the antenna are gravity, temperature and wind loads.

18 Description of the antenna

18.1 Drawings

The antenna was built in the beginning of the 60's by Rohr Corporation. At the same site a similar antenna was built by Blaw Knox Company a short time before. The engineers that built this antenna left Blaw Knox, keeping the drawings, made modifications on these and built the antenna that is of interest for us. Let us call it Fairbanks II. Both companies still exist but neither are involved with building antennas anymore. The companies have

since long lost track of their drawings of these antennas. At Goddard Space Flight Center there was a division that used to keep a set of drawings of this antenna, but the set together with a lot of other drawings was transferred to the archives at Bendix Field Engineering in Columbia, MD. An additional set complementing the first exists at the station itself. The drawings are marked Rohr Corporation and have the drawing numbers in the range of 930 to 980.

18.2 Material

Nearly all of the material used in the antenna is steel A-203. The exceptions are the surface panels of the dish and some few beams in the quadrupod. Neither has great influence on the stiffness of the structure. The code A-203 is according to ASTM (American Society for Testing and Materials) and with the help of material tables one gets the properties of the steel. The relevant properties are Young's Modulus $E = 2.0 \cdot 10^{11} N/m^2$, Poisson's ratio $\nu = 0.3$, density $\rho = 7900 kg/m^3$ and thermal expansion coefficient $\alpha = 1.2 \cdot 10^{-5} K^{-1}$. These are fairly constant for different types of steels.

18.3 The major structural parts of the antenna

The antenna is by its design naturally divided into five major parts: pedestal, x-wheel, y-wheel, dish and quadrupod. See Figures 16-20.

The pedestal rises in two pyramid shaped towers to 13m above the ground. About 3m up under the southern tower there is a house that contains hydraulic motors that drive the x-wheel. The x-wheel rests at the top of the two towers and its axis is oriented in the south to north direction. Because of the house and the weight of the hydraulic motors there is additional structural support under the house. However, above the floor of the house the two towers are identical.

The x-wheel has a radius of 7.6m and the two arms that hold the y-axis have a height of 7.3m. At the rim of the wheel large blocks of lead are attached that balance the wheel and the structure it supports around the x-axis. Just below the axis there is a platform that contains the hydraulic drives for the y-wheel. Throughout the wheel there are other platforms and ladders but these have little effect on the structure.

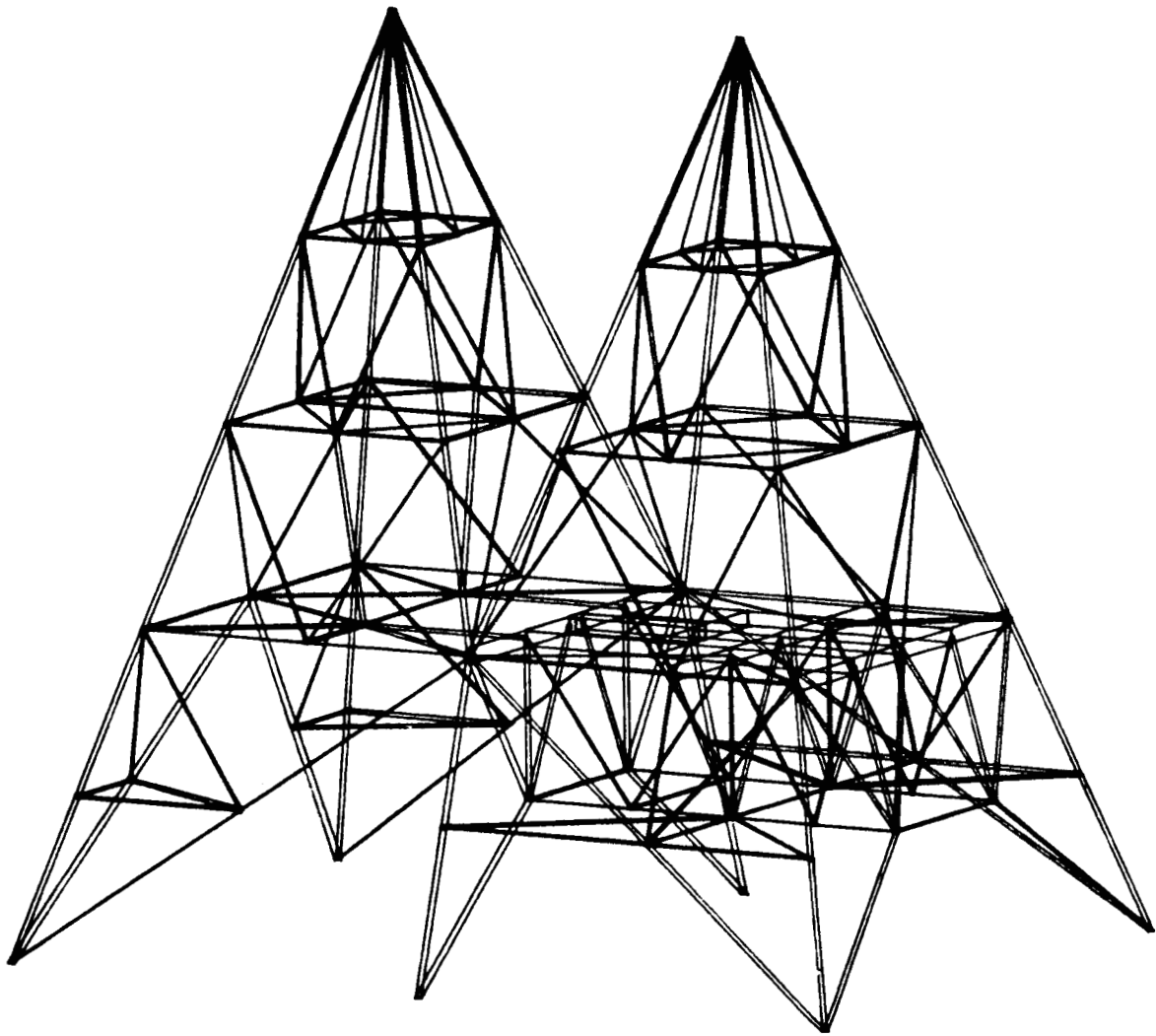

Figure 16: The pedestal. Note the additional structure in the southern tower. It supports the house (not in the figure) that contains the hydraulic drive for the x-wheel.

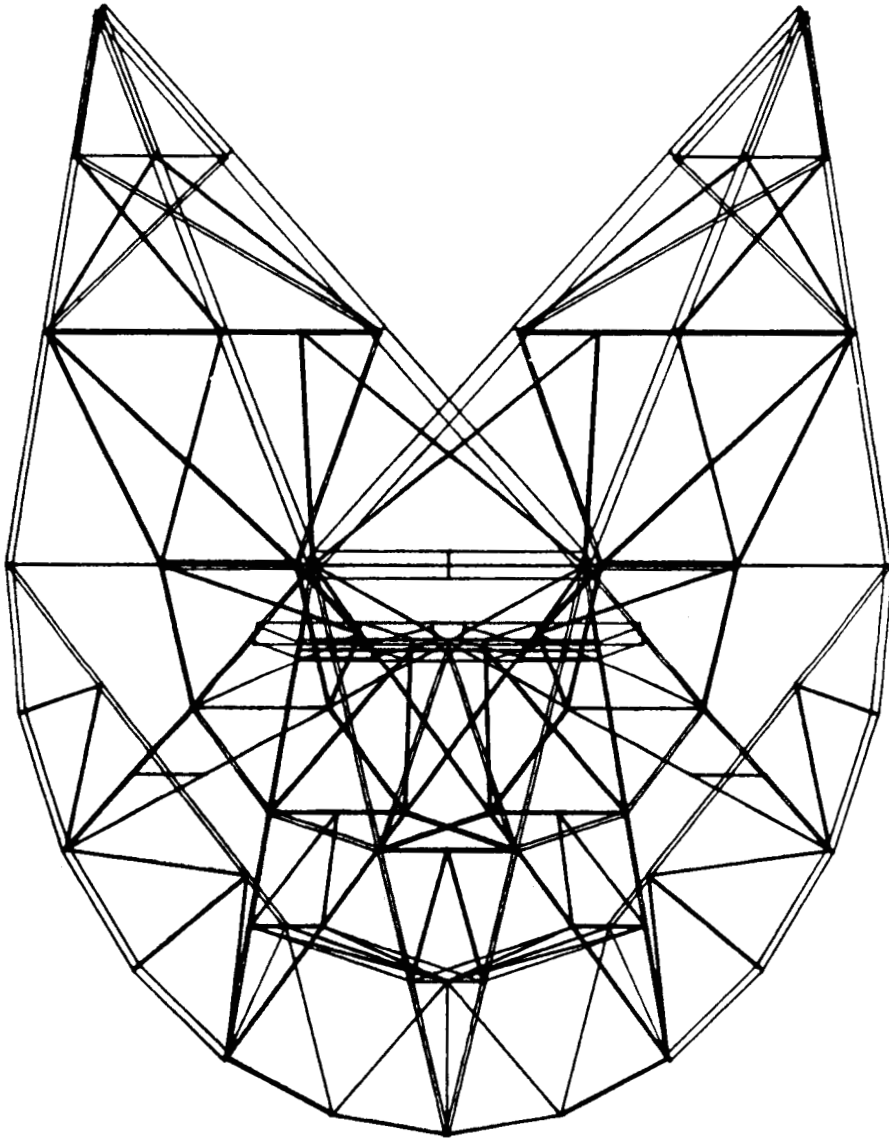

Figure 17: The x-wheel. The axis rests between the two towers of the pedestal in Figure 16. Note the platform under the axis. It contains the drive for the y-wheel.

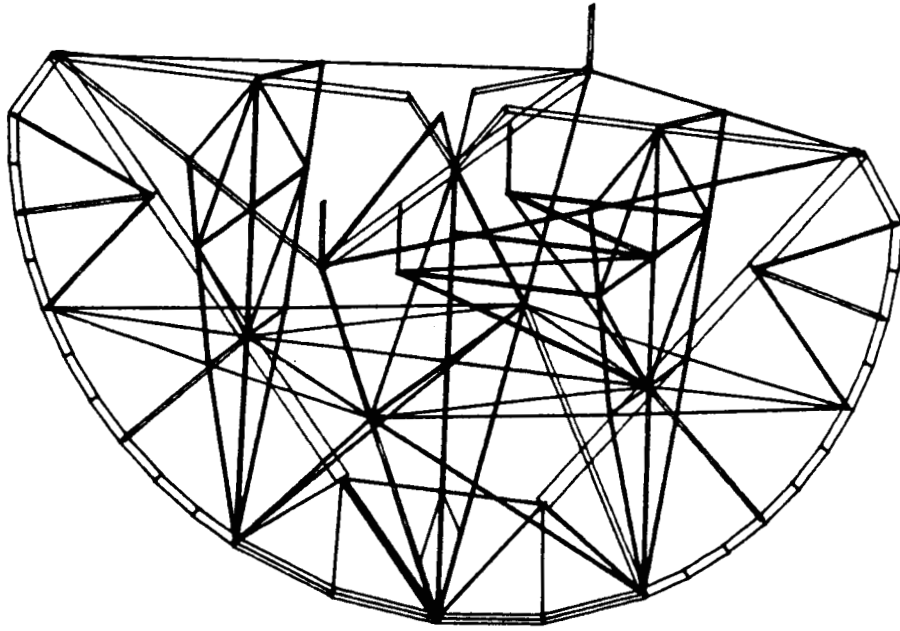

Figure 18: The y-wheel. The axis is attached to the two arms in the x-wheel. It is also attached to the dish in the square structure just above the axis.

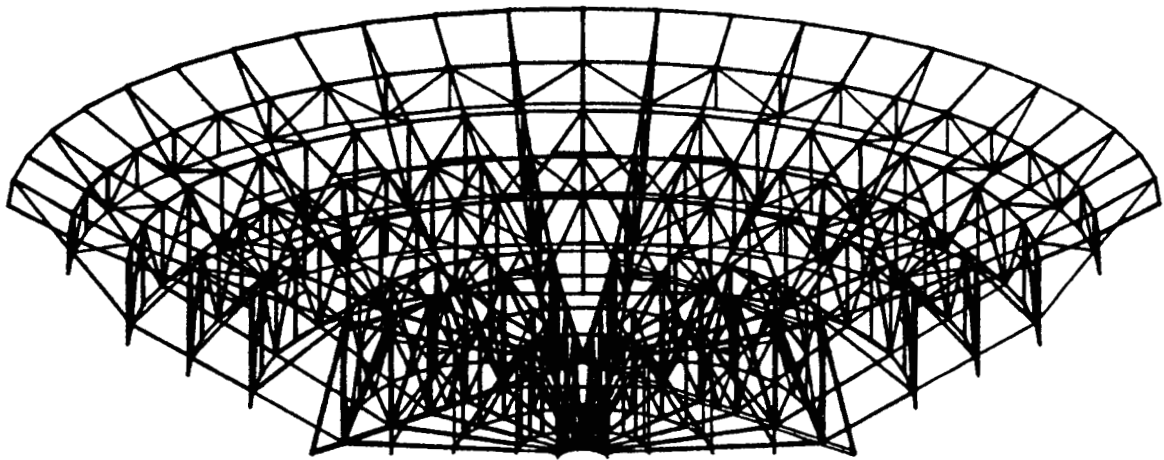

Figure 19: The dish. Only half of it is modeled to save time and disk space. The use of symmetry commands make it possible to do calculations as if a full model was constructed.

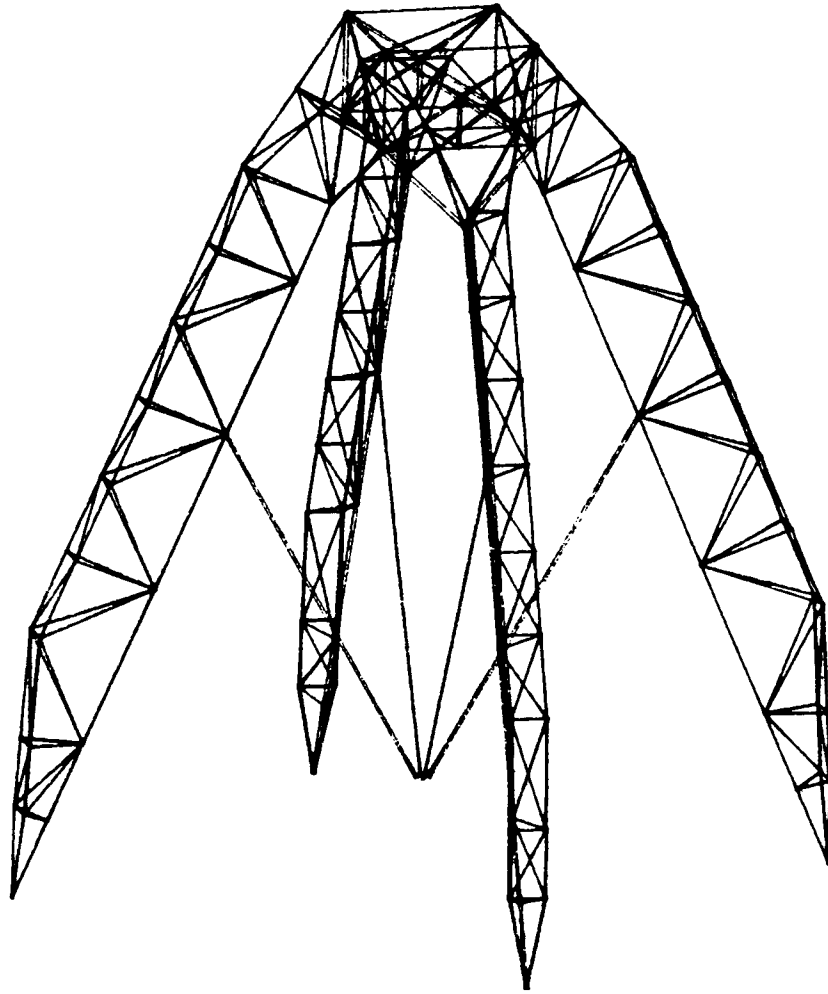

Figure 20: The quadrupod. It is attached to the dish and holds the receiver at its top in the focus of the dish.

The y-wheel has a radius of 6.7m and is in the same way as the y-wheel balanced around its axis. The axis is oriented east to west when the antenna points at the zenith. The y-wheel is shaped as a square just above its axis with the diameter as a diagonal in the square. This square structure is then attached to the dish.

The dish is built around a square structure to which the y-wheel is attached; it is called the square girder. It supports radial ribs that shape the dish in to a paraboloid with a focal length of 11m and a diameter of 26m, thus $f/D=0.42$. There are three kinds of ribs: in the drawings called A, B and C-ribs. In the dish there are eight of each rib and thus a total of 24 ribs. Connecting the ribs are beams outlining circles around the center. The surface is covered with aluminum panels adjusted to paraboloidal shape. This has been done several times with the help of theodelites.

From the four corners of the square girder the quadrupod rises 15m. The receiver is located in the box at the top. Halfway up along the legs four circular beams are attached to the center of the dish.

19 Forces and deformations

Three different kinds of forces act on the antenna that are of interest: gravity, thermal and wind loads.

Gravity is the easiest to handle because it has a constant magnitude and direction independent of time, whereas the other two depend on the season, the weather and the time of day. Gravity can be studied with good accuracy and the deformation depends only upon where the antenna is pointing. For the other two, values of deformation can be given only if additional parameters are given, such as temperature and wind speed.

The weather at Fairbanks reaches lows around -30 degrees Celsius during the winter and highs around 30 degrees in the summer. Figure 21 shows a plot of the lowest and highest temperature during the day for the last two years. Furthermore, temperature differences in the antenna have to be taken into account. Some parts may be in the sun whereas others are in the shadow.

Then there is the wind that has an even more random nature. For Fairbanks II the station crew say that the wind speeds are generally low

(less than 10m/s). The station is located in a valley running east to west which are also the most common wind directions. However, more precise data is not available because the wind meter is presently disconnected.

All these forces give rise to deformations in the antenna and it is important to sort out those deflections that are of interest and influence the accuracy in the VLBI measurements.

The VLBI reference point of the antenna is located in the center of the x-axis, deflections at this point are of interest. But there is also a time delay associated with the time it takes the incoming wave front to reach the receiver. Part II of this report discussed this and noted that deformations along the optical axis for the receiver and vertex of dish were of interest in this context, and so was also the change in focal length and the distance between the x and y-axis. This is the bare minimum that has to be studied. Other items such as pointing errors in the antenna will also be touched upon.

20 Models

The model of the antenna closely follows the five major parts described in Section 18. They can of course be analysed separately but to get more accurate results they have to be joined together. Figure 22 shows the x-wheel, y-wheel and dish joined together. The model is cut along the x-axis and can be used for different elevations of the y-wheel. Figure 23 shows the same parts joined together but now cut along the y-axis. This model is used to study the antenna at different X angles with the Y angle zero.

Calculations with these models requires 16-18 Mb of disk space. The quadrupod has not been added because it cannot be cut along the same boundaries as the other parts. (There are diagonal beams in the legs that crosses the boundary.) The absence of the quadrupod introduces an error but the stiffness that the quadrupod should add is much less than the stiffness in the massive square girder that supports the dish and the quadrupod. Furthermore, the calculated deformations in the square girder at the points that are attached to the quadrupod can be transferred to the quadrupod model as boundary conditions. This would then give higher accuracy in the calculated deformations in the quadrupod.

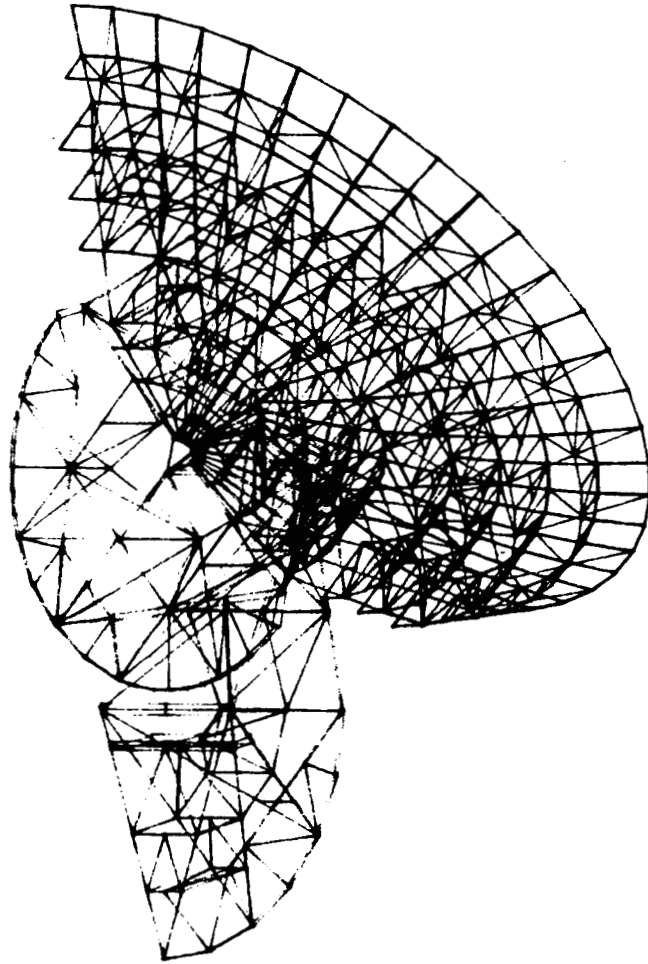

Figure 22: The x-wheel, y-wheel and dish joined together. The model is cut along the x-axis and is used to study different Y angles.

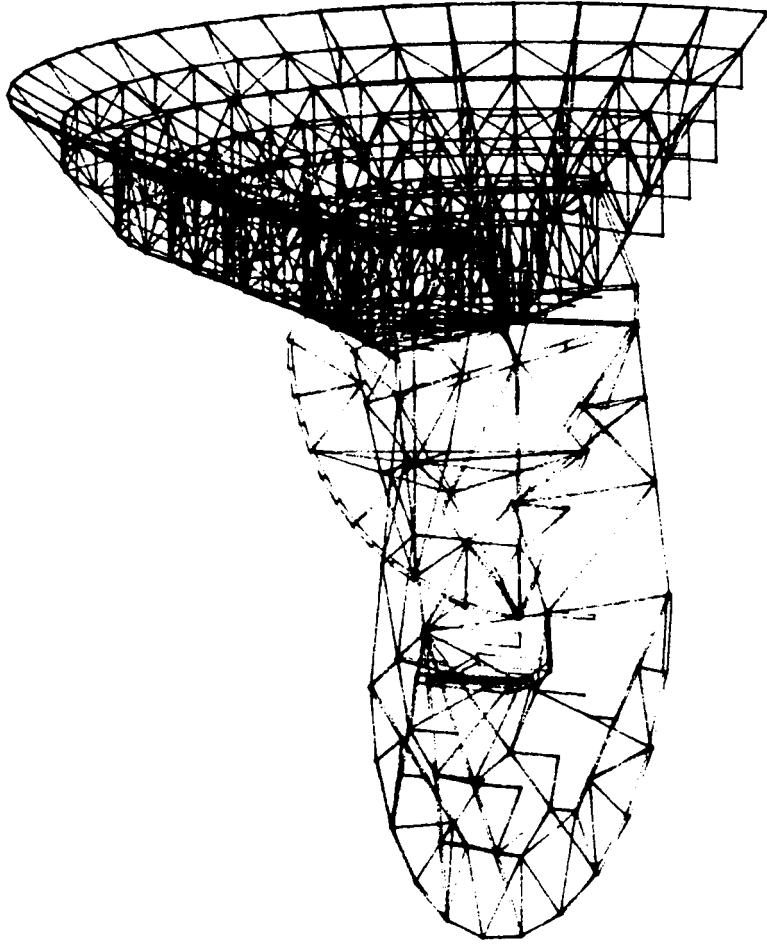

Figure 23: The same parts as in Figure 7. but this time the model is cut along the y-axis. The model is used to study different X angles.

Another way to assemble the parts is to use substructures. In Figures 24-26 the different substructures of the pedestal, x and y-wheel and the quadrupod are assembled at different X and Y angles. In these models the dish has been included as loads at the y-wheel. The model of the dish is too large for the COMPAQ to make a substructure that is useful.

21 Calculated deformations

21.1 Gravity

When presenting deformations calculated for gravity one has to take into account that the gravity forces are always acting on the antenna (they cannot be turned off like wind loads). This is especially important for the dish, it was adjusted to a paraboloid when pointing at zenith *with gravity acting on it*. This means that the deformations one is interested in are changes in the shape at other configurations relative to the zenith configuration. (Technically this is done by calculating deflections at different configurations and from them subtracting the deformations calculated at zenith; thereby the relative deformation at zenith becomes zero, just as required.) Thus what is of interest is changes in deformation from one configuration to another, not the absolute deformations from when the beams lay on the ground before they were put up in the structure.

21.1.1 The quadrupod

The quadrupod can be analysed by itself. The boundary condition then have to be that the ends of the four legs and the points at the center at the end of the four beams supporting the legs are not allowed to move. This is of course not correct but the analysis tells us about the stiffness in this structure. In Figure 27 the value of the deformation along the optical axis away from the dish is plotted at different elevations; in Figure 20 this is in the negative z direction. The deformation can be approximated by $0.15(1 - \sin EL)$ mm where EL is the angle of elevation. This is discussed in Part II, Sec. 15. Figure 28 shows the deflections orthogonal to the optical axis at different elevations. At zero elevation the feed box drops about 4.3 mm towards the ground with these boundary conditions. This time the

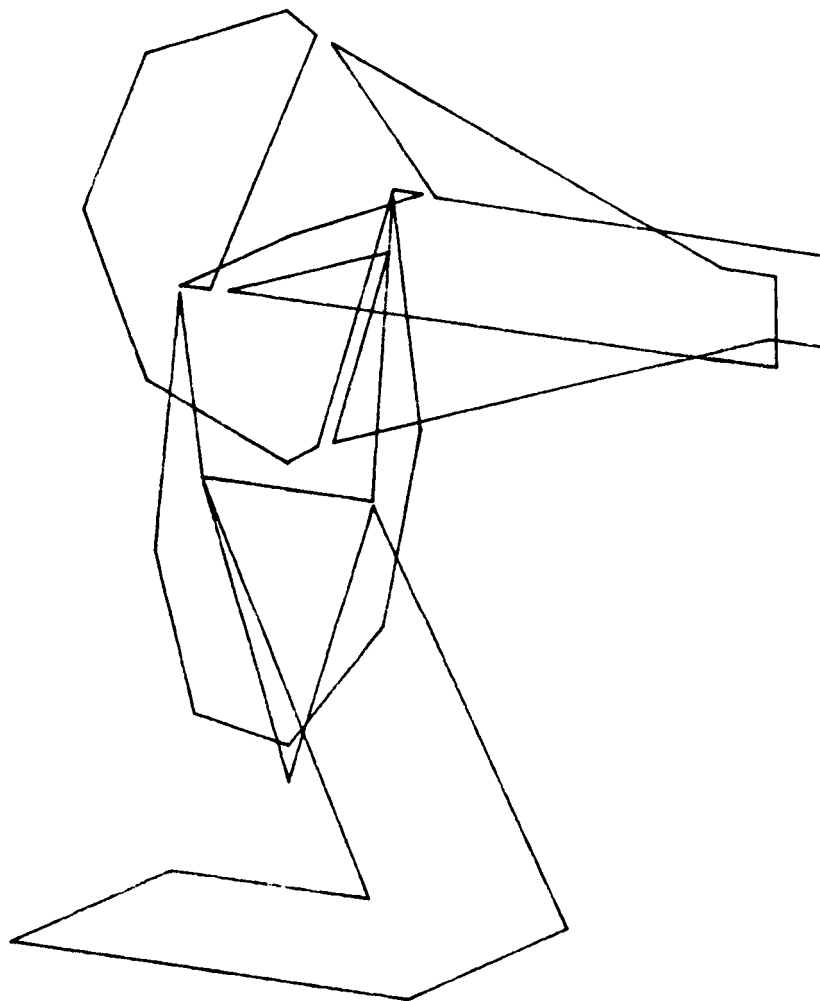

Figure 24: The pedestal, x-wheel, y-wheel and quadrupod assembled as substructures. The angles are: $X=0$ and $Y=90$.

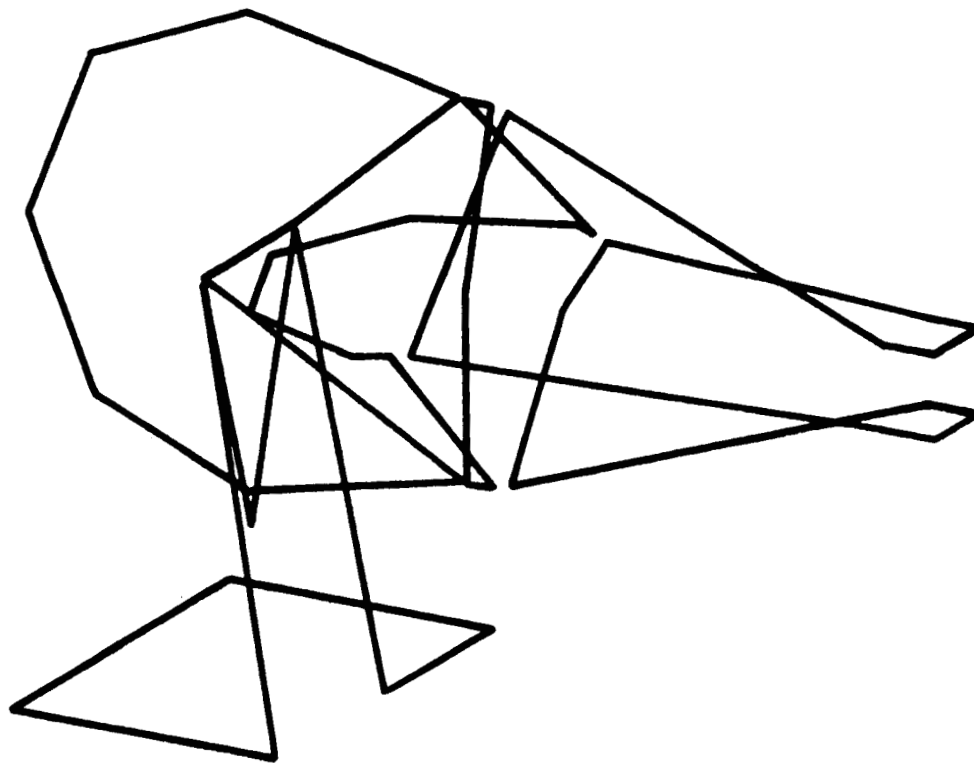

Figure 25: The substructures assembled with $X=90$ and $Y=0$.

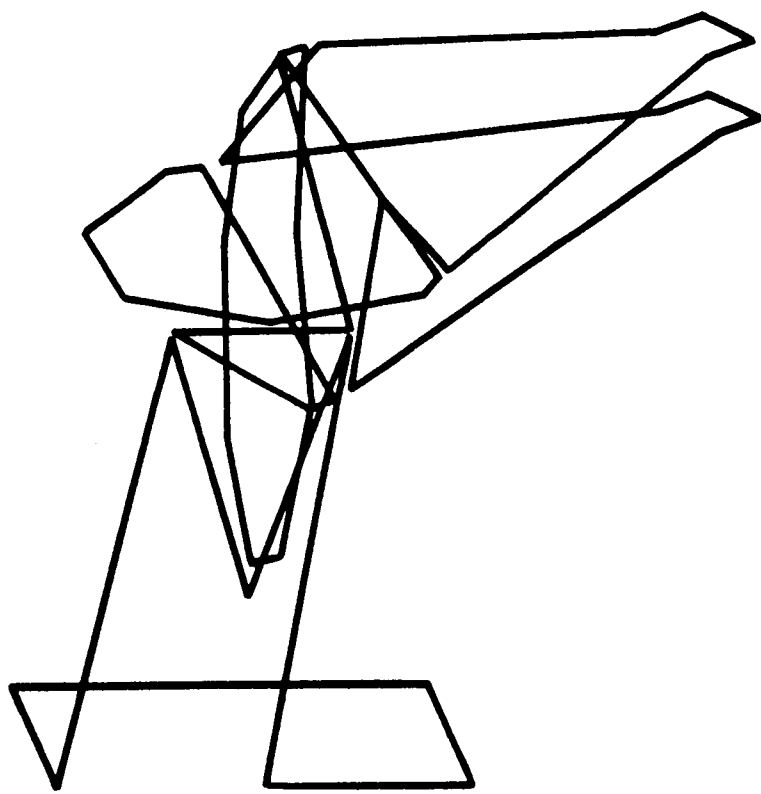

Figure 26: The substructures assembled with $X=45$ and $Y=45$.

deformation goes like the cosine of the elevation. Both these calculations were made with the gravity vector in the xz -plane in Figure 20. Figure 29 shows the deflection orthogonal to the optical axis (as in Figure 28) at the horizon when the gravity vector has different angles to this plane. The calculated value of it is nearly constant at 4.3 mm.

21.1.2 Results from the substructure model

The substructures have been assembled and analysed for the antenna pointing at different X and Y angles with the increment of 45 degrees. This means a total of three times three, that is nine, different structures that have to be analysed. As mentioned earlier, changes in the position of the reference point and distance between the x and y -axis are of interest. The reference point does not move very much due to the fact that the antenna is well balanced around the x -axis. The counterload is a few hundred pounds more than needed, so that the antenna will move to stowed position if the drive fails. This small force is negligible compared to other forces and results in deformations much less than 1mm. So the net effect of the antenna on the pedestal is approximately two vertical and identical loads in the two towers.

But the distance between the x and y -axis changes and so does the distance to the receiver. Table 1 summarizes the results for different X and Y angles. Here we note that the distance between x and y axis is 0.7mm shorter at $X=0$ than at $X=90$. Here the deformation is not set to zero at zenith. This way it is easier to see the behaviour of the deformations. There is also some dependence in Y angle but much less than compared to the above deflections. In Part II, Sec. 15 it was argued that the deflection should mainly be proportional to cosine of the X angle. This agrees reasonably with the results.

Also in Table 1 is the change in distance from the square girder to the feed/receiver. At zenith it is 0.15 mm shorter than when the antenna points at the horizon. Part II, Sec. 15 noted that this deflection should mainly be proportional to $\cos X \cos Y$ and again the calculated values agree well with this.

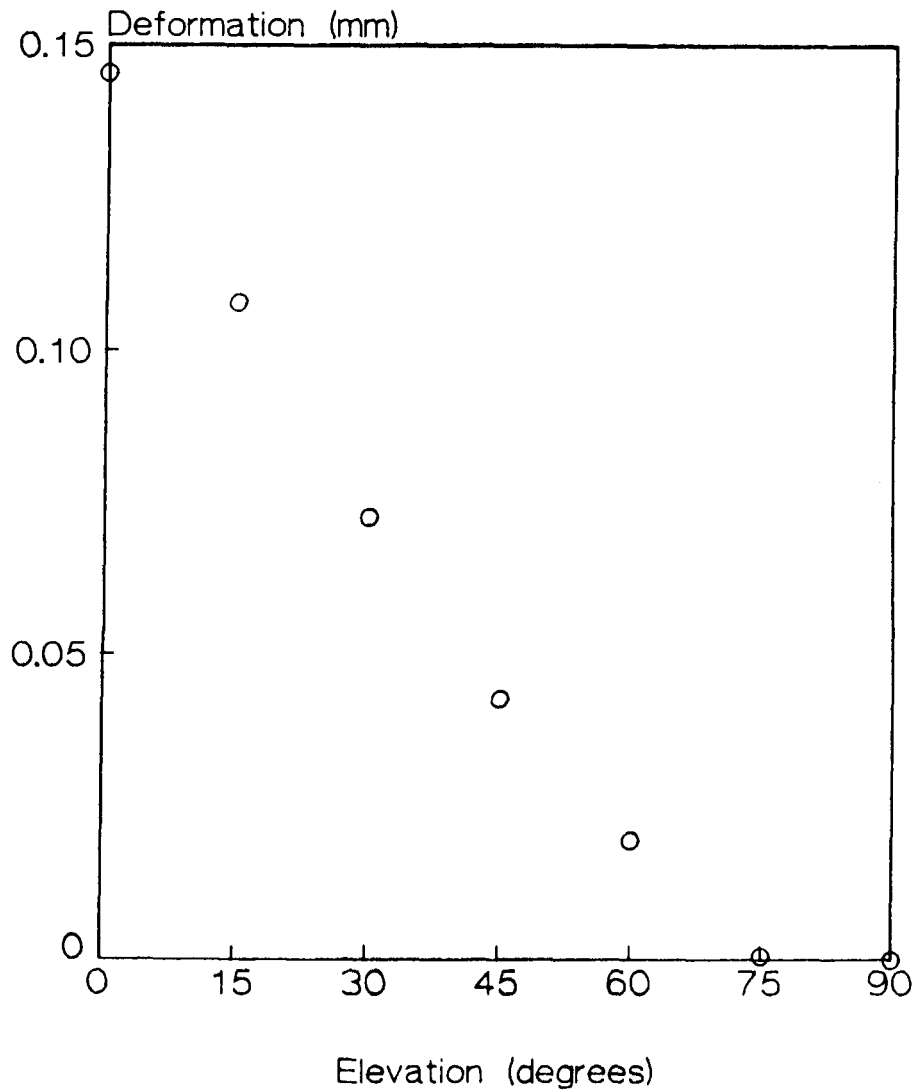

Figure 27: The deflection of the feed box away from the dish at different elevations. Note that the deflection at zenith is set to zero and that it moves away from the dish at lower elevations.

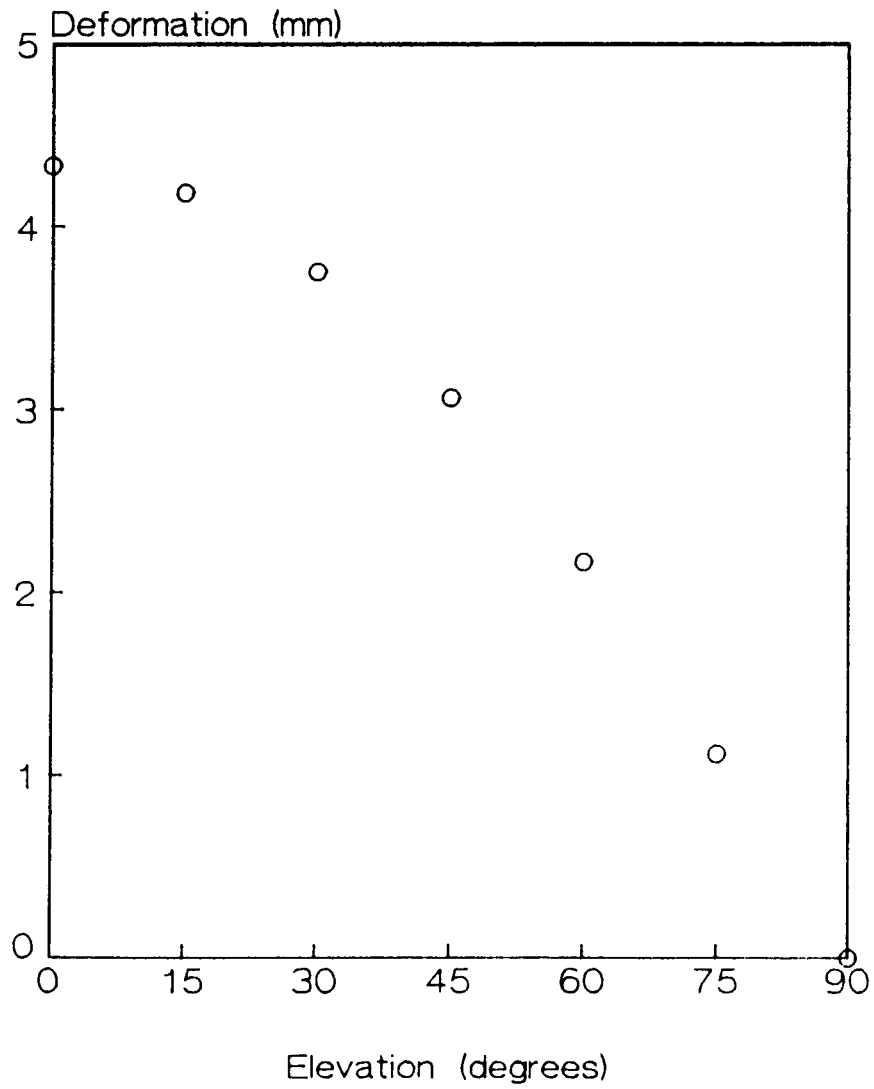

Figure 28: Deflection orthogonal to the optical axis in the feed box at different elevations. When the antenna points at the horizon the feed box drops 4.3 mm towards the ground.

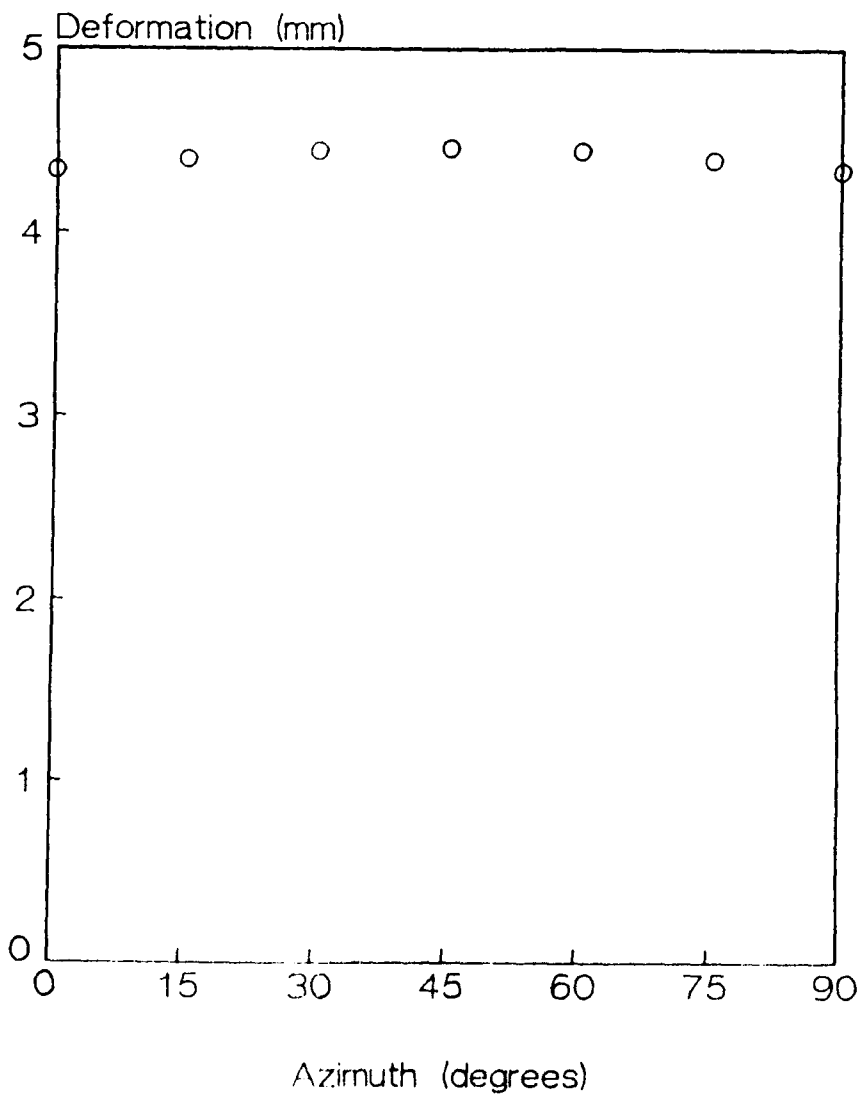

Figure 29: Deflections towards the ground in the feed box when the antenna points at the horizon. The deflections are given for different values of the angle between the gravity vector and the x-axis (see Figure 20). The gravity vector is orthogonal to the z-axis when the antenna points towards the horizon.

Y \ X	0	45	90
0	-6.8	-4.1	0.0
45	-6.4	-4.6	0.0
90	-7.6	-5.1	0.0

x to y axis

Y \ X	0	45	90
0	-0.16	-0.10	0.04
45	-0.12	-0.10	0.00
90	0.00	-0.02	0.00

feed to square girder

Table 1: The change in distance between x and y-axis, and the distance to the receiver from the square girder as a function of X and Y angle. Deformations given in millimeters.

21.1.3 The dish

To study the effects on the dish the models presented in Figures 22-23 were used. In this context the program PARABOL presented in Part I can be used to calculate the best fit paraboloid and changes in the average path length to the receiver.

The model presented in Figure 22 was used to study the deformation in the antenna with $X=0$ and different Y angles. The results are presented in Figure 30. We see that the focal length at horizon is 4.5 mm shorter than it was at zenith. We also note that the change follows the sine of elevation pretty well, just as mentioned in Part II. In the same figure the change in the position of the best fit vertex along the optical axis is also presented. It follows the same behaviour as the change in focal length, but with opposite sign.

In Figure 31 the same data is presented but now for $Y=0$ but X changing. Again the focal length is 4.5 mm shorter at the horizon than at zenith.

In Table 2 there is a comparison between the change in average path-length at different X and Y angles with the results presented in Part II, Sec. 14. According to this section the change should be

$$\Delta L = \alpha_V \Delta V + \alpha_f \Delta f + \alpha_R \Delta R \quad (21.1)$$

The comparison uses the results in Figures 30-31, and thus do not take into account the change in the receiver position. If one uses $\alpha_V = -1.8$ and $\alpha_f = 0.2$ the agreement is very good. If we as boundary conditions in the quadrupod model use the calculated deformations in the square girder, we find that the receiver has moved away 1.3mm along the optical axis at the horizon. (The distance to the dish has still increased by 0.15mm because the dish has also moved.) The movement of the receiver follows the same behaviour as in Figure 27. If we use the above data and correct the data in Table 2 with $\alpha_R = 0.8$ we get the results presented in Table 3. We see that the change is approximately $-2.4(1 - \cos X \cos Y)$ mm, that is $-2.4(1 - \sin EL)$ mm.

+ focal point Δ vertex

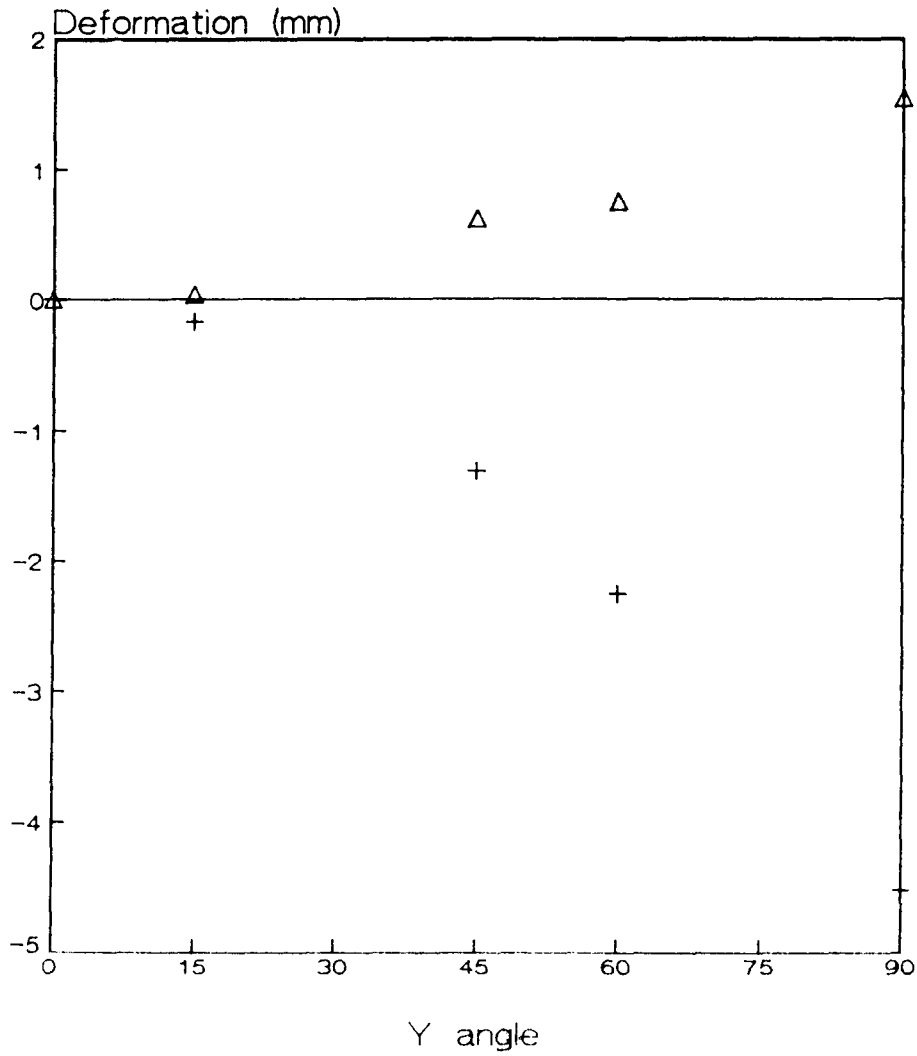

Figure 30: The change in focal length and position of the best fit vertex along the optical axis as a function of the Y angle when X=0.

+ focal point Δ vertex

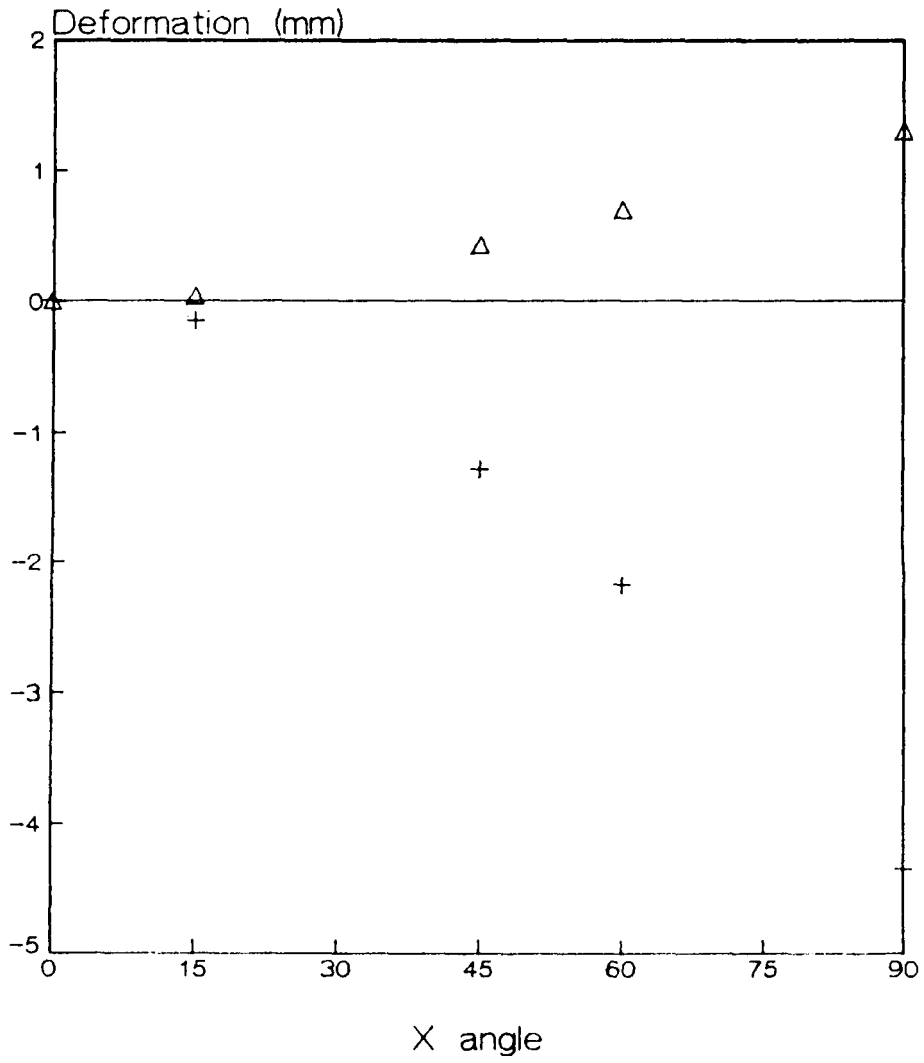

Figure 31: The change in focal length and position of the best fit vertex along the optical axis as a function of the X angle when $Y=0$.

Y \ X	0	45	90
0	0	-1.07	-3.33
45	-1.48	—	—
90	-3.80	—	—

PARABOL

Y \ X	0	45	90
0	0	-1.03	-3.20
45	-1.43	—	—
90	-3.67	—	—

$$\Delta L = -1.8\Delta V + 0.2\Delta f$$

Table 2: Comparison between the calculated average path length change (in mm) with PARABOL and $\Delta L = -1.8\Delta V + 0.2\Delta f$. Here the change in receiver position along the optical axis ΔV and change in focal length Δf are taken from Figures 30-31. Note that the change in distance between x and y-axis is included in the change of vertex position.

Y \ X	0	45	90
0	0	-0.8	-2.3
45	-1.1	-	-
90	-2.6	-	-

Table 3: The results in Table 2 adjusted for the movement of the receiver.

21.1.4 Pointing corrections

Due to deformations in the dish and the structure that supports the receiver corrections in the X and Y angle have to be added to get the optimum pointing on a source. Ed Himwich (Interferometrics Inc./GSFC, Code 621.9) has the literature and knows a lot about pointing and we have discussed the results in this section. The presented pointing parameters have been determined by Ed.

The terms in the correction that corrects for deformation are for the X angle $-0.00968 \sin X \sec Y$. This is the value that should be added in degrees to the angle to point on source. For Y angle the term is $0.153 \cos X \sin Y$. From this we see that when $X=0$ and $Y=90$ the correction in X angle is 0 and the correction in Y angle is 0.153 degrees. For the opposite situation $X=90$ and $Y=0$ the correction in X angle is -0.00968 and for Y angle 0.

Figure 32 illustrate how the correction Δ can be calculated. From the figure we get that $\Delta = (V + R)/f - 2\alpha$. We get V and α from the program PARABOL and R is calculated by transferring the deflections in the connection points in the dish to the quadrupod calculated with the models in Figures 22-23 and applying gravity.

For $X=0$ and $Y=90$ the calculated values are $V = 6.16 \cdot 10^{-2}\text{m}$, $R = 2.62 \cdot 10^{-2}\text{m}$ and $\alpha = 2.97 \cdot 10^{-3}\text{rad}$. With $f = 10.97\text{m}$ this gives $\Delta = 2.07 \cdot 10^{-3}\text{rad}$, that is 0.12deg. This agrees well with the experimental value.

For $X=90$ and $Y=0$ the calculated values are $V = 6.09 \cdot 10^{-2}\text{m}$, $R = 1.60 \cdot 10^{-2}\text{m}$ and $\alpha = 3.05 \cdot 10^{-3}\text{rad}$. This gives a correction $\Delta = 0.051\text{deg}$, which has the opposite sign of the experimentally determined correction. But note that we subtract two values of equal magnitude to calculate the correction and thus errors have great influence.

21.2 Temperature

When metal is heated or cooled it expands or contracts. The basic relationship for a simple beam is

$$\Delta L = \alpha \Delta T L \quad (21.2)$$

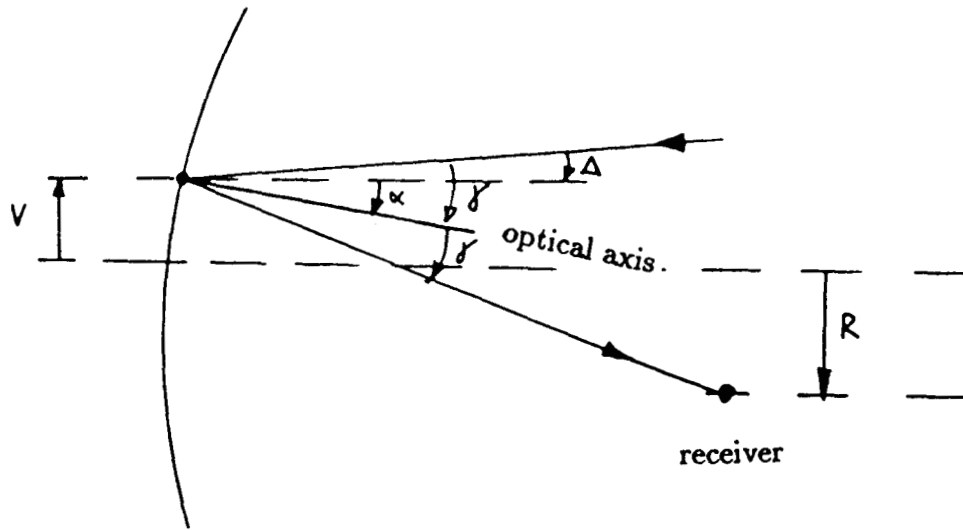

Figure 32: The figure illustrates the pointing correction. The vertex moves V , the receiver moves R and the optical axis is rotated an angle α . If gravity were turned off all of these would be zero and the antenna would point at the horizon. But with gravity the antenna has to add Δ to its zenith angle for a wavefront coming from the horizon to reach the receiver. From the figure we get $\alpha + \gamma = (V + R)/f$ and $\Delta = \gamma - \alpha$. Thus we have $\Delta = (V + R)/f - 2\alpha$.

where ΔL is the change in length, α the thermal expansion coefficient, ΔT the change in temperature and L the length of the beam. The calculated deformations agree with this formula and indicate that metal is metal and that changes in height and distances do not depend to a high degree on the structure when it comes to changes in the temperature.

21.2.1 Substructures

The model consisting of four substructures has been used to calculate the effect of a 10 K temperature rise. This has been done for the nine combinations of the x and y-wheel mentioned in Sec. 21.1.2. It turns out that the change in height of the pedestal is 1.8mm, the distance between x-axis and y-axis is 0.8mm and the distance from the feedbox to the square girder is 1.6mm independent on the configuration of the antenna. Table 4 summarizes these results. The values one gets if one uses Eq. 21.2 and the rough dimensions in the antenna (13m, 7.6m and 13m) are 1.6mm, 0.9mm and 1.6mm. Furthermore, the change for any other temperature is easy to calculate because the deformations are proportional to the change in temperature. For example, if the change is 20 degrees Celsius the distance between the x and y-axis should change $2 * 0.8 = 1.6$ mm. For seasonal changes of 50 K the change in height of the pedestal, the distance between x and y-axis, and height of quadrupod should be 9mm, 4mm and 8mm.

The effects of differential heating of the pedestal when parts of it are in the shadow and other parts of it are in the sun has also been studied. The pedestal tilts away from the sun and a rough calculation with a temperature difference of 5 degrees between sun and shadow results in a maximum tilt of 1.2mm. The result is schematically presented in Figure 33.

21.2.2 The dish

The same models as used in Section 21.1.3 were used to study the effects of a 10 K temperature rise in the structure. The results for the focal length are presented in Table 5. We see that the change in focal length is independent of either X or Y angle. The change in distance between vertex and y-axis is 0.4mm. And if we combine this with the change in height of

Y \ X	0	45	90
0	0.90	0.90	0.90
45	.90	0.89	0.89
90	0.90	0.90	0.89

x to y axis

Y \ X	0	45	90
0	1.6	1.6	1.6
45	1.6	1.6	1.6
90	1.6	1.6	1.6

feed to square girder

Table 4: Changes in the antenna for different X and Y angles for a 10 K rise in temperature. Deflections are in millimeters.

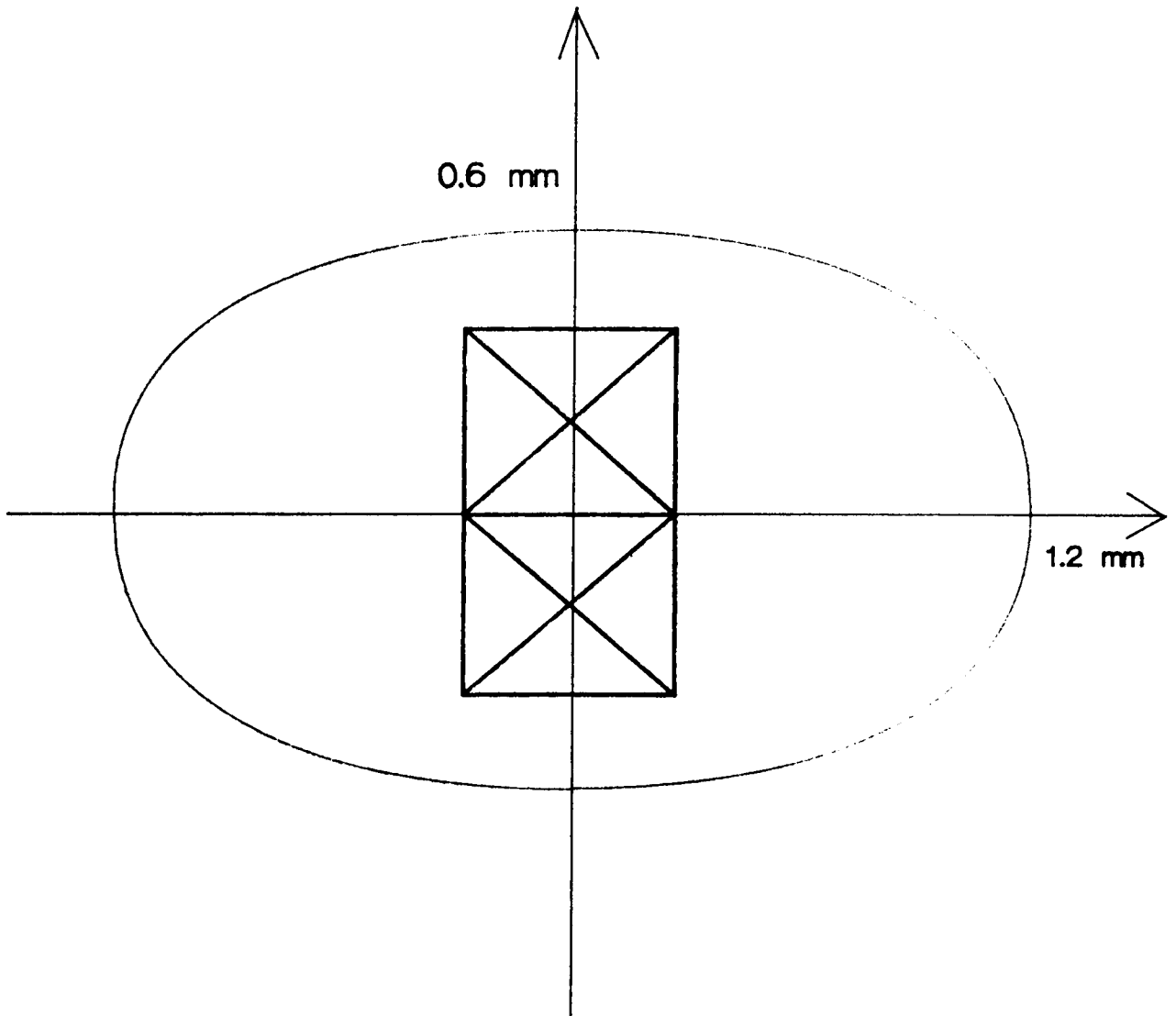

Figure 33: The pedestal tilts away from the sun; a differential temperature of 5 K is assumed. The figure schematically presents the behaviour in relation to the orientation of the pedestal.

the quadrupod we can calculate the change in path length through the dish with Eq. 21.1 and the same values for the coefficients as in Sec. 21.1.3: $\Delta L = -1.8 \cdot 0.4 + 0.2 \cdot 1.3 + 0.8 \cdot 1.6 = 0.8mm$. Here the change in distance between x and y-axis is not included.

21.3 Wind

When studying the wind loads the program WINDLOAD, described in Part I, Sec. 7, was used. Only wind forces acting on the dish surface are taken into account. The deformation were calculated with the models presented in Figures 22-23 with a wind of 10 m/s. Note that the forces are proportional to the square of the wind speed, and thus also the deformations. In Table 6 the changes in focal length in the antenna at different configurations are presented.

We see that the maximum change is around 60 degree elevation with the wind blowing into the dish. This has to do with the fact that the dish at this elevation has the leading edge nearly parallel to the ground and acts as a wing. Around this elevation the wing stalls and pressure maximas occur.

The change in the position of the vertex along the axis is at most 0.1 mm and can for an accuracy in millimeters be neglected. Likewise, changes in the position of the center of the x-axis are on the same order.

22 Measurements

Two different measurements have been done to verify that the calculated measurements agree with actual deformations. At Fairbanks it is possible to optimize the position of the receiver by moving it along the optical axis. Figure 34. shows the result of these measurements. The optimum position is 7mm closer to the dish at the horizon. The calculated value is 4.5mm. The fitted curve is proportional to $\sin EL$ just as expected.

The other measurement is a good test of the substructure model. When the antenna was in service position, the configuration presented in Figure 25, it was loaded with 175 lb in the receiver box at the top of the quadrupod. With a 5 arcsec level the deformation was measured to be 0.14 mm. The calculated value is 0.19mm.

X \ Y	0	45	90
0	1.32	1.32	1.32
45	1.32	—	—
90	1.31	—	—

focal length

Table 5: The change in focal length (in mm) at different X and Y angles for a 10 K rise in temperature.

Y \ X	0	30	90
0	-0.3	3.2	2.6
30	3.2	-	-
90	2.6	-	-

WIND 10 M/S; FRONT

Y \ X	0	30	90
0	-0.3	-0.7	-1.5
30	-0.8	-	-
90	-1.6	-	-

WIND 10 M/S; BACK

Table 6: The changes in focal length (in mm) for a 10 m/s wind blowing at the antenna into the dish (front) and from behind (back). Note the maximum around 60 degrees of elevation when the wind blows into the dish.

△ test 1 ○ test 2 ● test 3

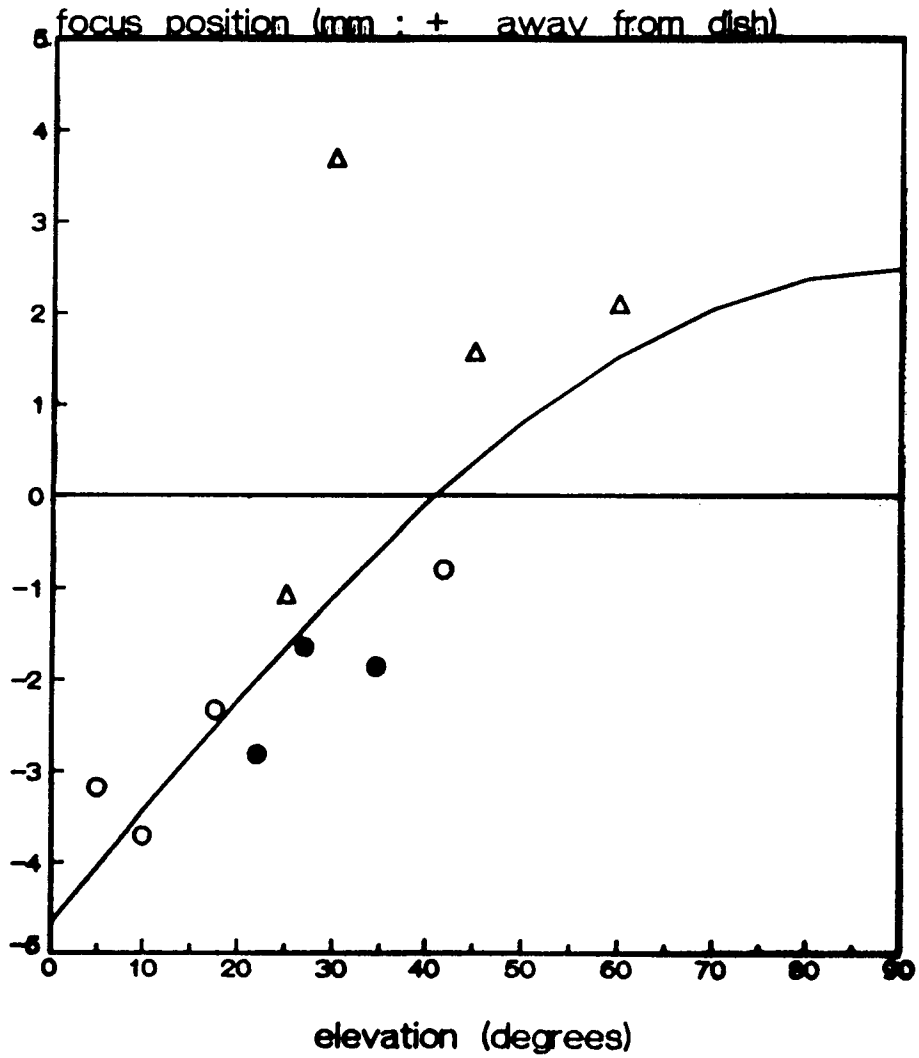

Figure 34: The measured optimum focus position as a function of zenith angle.

Discrepancies between calculated and measured values can be explained by inaccuracies in the models. First some structural data might not be correct. When I visited Fairbanks, I made measurements of the dimensions in the antenna, but this just covered a small part of the antenna. During the work on the models just notes taken from the drawings were available and all details were in no way covered. There is a possibility for errors. Furthermore, it is known that the bolted joints in an antenna start to loosen up and members start to be able to move in the joints when the antenna has been moved back and forth a couple of years. Bolts then have to be replaced.

23 Conclusions for the Fairbanks antenna

The deformations in the VLBI antenna at Fairbanks are on the order of a few millimeters. The calculated values agree reasonably well with the measured values. At present these deformations are smaller than the errors that the present VLBI measurements have. But if millimeter accuracy - which is the stated goal - is to be achieved these deformations have to be taken into account.

The importance of the various deformations are in decreasing order: temperature, gravity and wind. A first rough model of the change in path length through the antenna is

$$\Delta L = \Delta T(a_0 + a_1 \cos X) + a_2(1 - \cos X \cos Y) \quad (23.1)$$

where ΔT is the change in temperature from some reference temperature. Here $\Delta L = 0$ at zenith for $\Delta T = 0$. The change in distance between x and y-axis was 0.8 mm for 10 K. This means that a_1 is on the order of -0.1 mm/K. From Section 21.2.2 we can in the same way see that a_0 , the change through the dish, should be on the order of .1 mm/K and from for example Table 3 we see that a_2 should be on the order of -2mm.

Furthermore the height of the pedestal changes with temperature, about 0.2mm per K.

If the VLBI measurements reaches millimeter accuracy these effects should be visible and thus these coefficients could be determined experimentally. This also requires some sort of temperature sensor on the antenna.

Several sensors may make it possible to predict the tilt from differential heating.



Report Documentation Page

1. Report No. NASA TM-100696		2. Government Accession No.		3. Recipient's Catalog No.	
4. Title and Subtitle Deformations in VLBI Antennas			5. Report Date January 1988		
			6. Performing Organization Code 621.0		
7. Author(s) T. A. Clark and P. Thomsen			8. Performing Organization Report No. 88B0090		
			10. Work Unit No.		
9. Performing Organization Name and Address Goddard Space Flight Center Greenbelt, Maryland 20771			11. Contract or Grant No.		
			13. Type of Report and Period Covered Technical Memorandum		
12. Sponsoring Agency Name and Address National Aeronautics and Space Administration Washington, D.C. 20546-0001			14. Sponsoring Agency Code		
			15. Supplementary Notes P. Thomsen is affiliated with Interferometrics, Inc., Vienna, Virginia, 22180; T. A. Clark is affiliated with Goddard Space Flight Center, Greenbelt, Maryland, 20771.		
16. Abstract The authors present a study of deformations in antennas with the emphasis on the influence on VLBI measurements. GIFTS structural analysis program has been used to model the VLBI antenna in Fairbanks, Alaska. The report identifies key deformations and studies the effect of gravity, wind and temperature. Estimates of expected deformations are given.					
17. Key Words (Suggested by Author(s)) Structural analysis Deformation Antennas VLBI measurements			18. Distribution Statement Unclassified - Unlimited Subject Category 39		
19. Security Classif. (of this report) Unclassified		20. Security Classif. (of this page) Unclassified		21. No. of pages	22. Price