

NASA Contractor Report 180854

Study of Industry Requirements That Can Be Fulfilled by Combustion Experimentation Aboard Space Station

(NASA-CR-180854) STUDY OF INDUSTRY REQUIREMENTS THAT CAN BE FULFILLED BY COMBUSTION EXPERIMENTATION ABOARD SPACE STATION Final Contractor Report (Priem Consultants) 62 p

N88-19377

CSCL 22A G3/85

Unclas
0125888

Richard J. Priem
Sverdrup Technology, Inc.
Lewis Research Center
Cleveland, Ohio

March 1988

Prepared for
Lewis Research Center
Under Contract NAS3-24105



National Aeronautics and
Space Administration

TABLE OF CONTENTS

I. EXECUTIVE SUMMARY	1
I.1 Approach Used in Study	1
I.2 Survey of Interests	2
I.3 Findings	3
I.4 Recommendations	4
II. INTRODUCTION	4
III. INDUSTRIAL INTEREST IN MICROGRAVITY COMBUSTION EXPERIMENTS	7
III.1 Fire Safety for Terrestrial Applications	7
III.2 Fire Safety for Space Applications	8
III.3 Propulsion and Power Applications	9
III.4 Industrial Burners	10
III.5 Pollution Control	11
IV. MICROGRAVITY COMBUSTION EXPERIMENTS	12
IV.1 No Flow System with Liquid or Solid Fuels	13
IV.1a Requirements for No Flow Experiments with Solids and Liquids	14
IV.2 Homogeneous Mixtures of Fuel and Oxygen	15
IV.2a Requirements for Homogeneous Mixture Experimental Apparatus	15
IV.3 Low Flow System with Solid or Liquid Fuels	16
IV.3a Requirements for Low Flow with Solid and Liquid Experiments	17
IV.4 Low Flow System With Gaseous Fuels	17
IV.4a Requirements for Low Flow with Gaseous Fuel Experiments	18
IV.5 High Pressure Combustion Systems	19
IV.5a Requirements for High Pressure Combustion Experiments	19
IV.6 Special Burner Systems	20
IV.6a Fire Safety Modeling of Space Station	20
IV.6b Requirements for Fire-Safety Modeling of Space Station	21
IV.6c Standard Dust Explosion Tester	22
IV.6d Fluidized Beds	22
V. DISCUSSION OF INDUSTRIAL INTERESTS AND EXPERIMENTS	22
VI. SPACE STATION FACILITY REQUIREMENTS	24
VII. ACCOMMODATION IN SPACE STATION	25
VII.1 Disposing of Combustion Products	26
VII.2 Providing a Laboratory Environment	26
VII.3 General Use of Diagnostic Equipment	26
VIII. SUMMARY OF FINDINGS	27
IX. RECOMMENDATIONS	28
APPENDIX A. List of contracts made during this study giving name, company affiliation, address, phone number, experimental area, and type of interest	30

STUDY OF INDUSTRY REQUIREMENTS THAT CAN BE FULFILLED BY COMBUSTION
EXPERIMENTATION ABOARD SPACE STATION

Richard J. Priem
Priem Consultants Inc.
Cleveland, Ohio

I. EXECUTIVE SUMMARY

This study was directed at determining the interest in microgravity combustion experiments in Space Station and identifying the future requirements for commercially motivated combustion experiments on Space Station.

I.1 Approach Used in Study

The objectives were accomplished by contacting 181 individuals from 113 organizations. The contacts were divided equally among:

- (1) Commercial organizations involved in producing a product
- (2) Universities
- (3) Government organizations or industrial organizations totally devoted to performing research

The interest of the commercial sector in Space Station combustion experiments can be divided into five interest groups:

- (1) Fire safety for terrestrial applications
- (2) Fire safety for space applications
- (3) Propulsion and power
- (4) Industrial burners
- (5) Pollution control

The various types of experiments that may be considered for microgravity combustion studies in Space Station were arbitrarily divided into six categories:

- (1) No flow system with solid or liquid fuels
- (2) Homogeneous mixtures of fuel and air
- (3) Low flow system with solid or liquid fuels
- (4) Low flow system with gaseous fuel
- (5) High pressure combustion systems
- (6) Special burner systems

With these categories it was possible to describe the general requirements for each type of experiment without going into special equipment needs, etc., that would be unique to individual experiments or individual experimenters.

I.2 Survey of Interests

The results of the survey showed that the organizations consulted had varying interests in microgravity combustion experiments in Space Station. The amount of actual involvement in experiments would depend on the facilities provided and limitations imposed on experiments performed in Space Station.

Everyone stated the desire for a laboratory environment in which a series of tests could be performed with time between test series to analyze the data and modify the test conditions for the next series of conditions. Without this type of environment it is believed that the time, effort, and cost required to develop an experiment would exceed the value of the experiment. For many experiments the laboratory environment is the major advantage in conducting experiments in Space Station. Without the laboratory environment many experimental packages would have to be taken to space to obtain the data required in one program. Using several flights would increase the cost and total duration of the program. Using prepackaged experiments many of the programs could be conducted with other facilities with similar increase in costs and duration of the program. The need for a laboratory environment requires Space Station to have a supply of air for experimental use and a means of disposing of combustion products. The desire to change the test conditions after reviewing the data will also represent a problem that must be addressed to permit NASA to have the controls needed to assure the safety and usability of the Space Station.

The strongest interest in all types of experiments was from the Fire Safety with Terrestrial Applications, Propulsion and Power, and Pollution Control groups. The Fire Safety with Space Applications group had major interests in several experiment types while the interests of the Industrial Burner group were concentrated in a few experiment types.

The liquid or solid fuels experiments involving no flow or low flow had the highest interest. Homogeneous mixtures and gaseous fuel experiments had medium interest with all the groups. High pressure combustion and special burner experiments had generally low interest, although they were of importance in a few specific applications.

Requirements for the combustion facility and individual experiments are provided. All of the tests could be performed in a combustion facility that fits into the double rack Space Station layout. Combining the most severe conditions from each experiment type (but not including the high power requirements for the high pressure experiments) that could be conducted in the combustion facility results in the following estimated requirements for a typical test program as indicated by the technical interviews:

Frequency of tests - number	60 (in a program)
Frequency of tests - number of series	3 to 4
Frequency of tests - time for a series	5 hr maximum
Frequency of tests - length of individual test	1 hr maximum
Total weight of facility and experimental apparatus	200 kg
Mass of the air used in experimental program	100 kg
Volume of air used in experimental program	100 m ³
Mass of fuel used in experimental program	10 kg
Volume of fuel used in experimental program	30 m ³

Power requirements - maximum	2 kW
Power requirements - energy	0.5 kWh
Thermal load - maximum	0.5 kW
Thermal load - combustion energy	1 kWh

The most difficult problem within these requirements is the need to dispose of the 100 m³ of warm combustion products created in a 5-hour test series. The use of fire extinguishing and fire suppressant materials in some of these studies means the combustion products could contain toxic and/or corrosive gases. The corrosiveness would impose additional problems regarding the materials used in the exhaust system (stainless steels may require a teflon coating).

The survey indicated that it would be difficult to justify and support a microgravity combustion experiment by one organization. Lack of ability to justify programs indicates a need to combine experiment needs of different groups into one experiment.

The survey results indicated a desire to have developed modular diagnostic equipment that are external to the combustion facility. These include:

- (1) Video system
- (2) Temperature measuring system (using lasers)
- (3) Species and particle measuring system (using lasers and mass spectrometer)

With the equipment being modular and external it could be used on different experiments (including noncombustion experiments that have the same needs) and for Space Station operations.

I.3 Findings

The commercial sector has a definite interest and need to conduct certain microgravity combustion experiments in Space Station. The main motivation for these interests is to use microgravity as an idealized non-convective environment for experiments aimed at obtaining a better understanding of combustion phenomena associated with new and/or better products.

Interest in microgravity combustion experiments covers all aspects of combustion and all types of organizations. Many individuals and organizations want to perform the same type of experiments, which can be accomplished in the same program with one set of equipment. None of the individuals or organizations were concerned about proprietary data as everyone is interested in basic information.

Individual organizations do not have sufficient resources or interest to completely undertake a microgravity combustion experiment alone. A commercial organization has difficulty initiating and supporting a program that will require 5 to 10 years to complete.

Equipment requirements to meet the majority of the future needs are simple. Using a general combustion facility with several specific pieces of

apparatus to perform different types of experiments will meet most future needs.

Everyone interested in microgravity combustion experiments expressed a need to have a laboratory environment facility in Space Station. This means the capability of performing a series of tests with time between series to analyze the data and change the test matrix or test procedures for the following series.

I.4 Recommendations

To obtain the maximum involvement of the private sector in Space Station the following recommendations are made:

(1) Design and develop a combustion facility for Space Station with a laboratory environment that allows multiple usage for all categories of combustion test techniques. A laboratory environment would permit a series of tests to be conducted with time to analyze the data between series and change test conditions for the next series of tests.

(2) Develop a technology plan that has the commercial sector involved in every experiment from its initial planning until the tests are completed on Space Station. Involving the commercial sector will reduce the cost to each group and increase the value of the experiments.

(3) Provide support (development funds or flight expenses) for experiments or programs that include tests to meet the needs of several groups and have financial involvement and interest from the different organizations (at least one of which must be commercial). Provide modular diagnostic units for measuring and recording combustion phenomena that are external to the combustion facility. These units can be used in other experiments (including non-combustion experiments) and Space Station operations.

II. INTRODUCTION

Microgravity combustion has been a growing field of interest since the initial studies were conducted by Kumagai and Isoda at the University of Tokyo in the 1950's. Since then major research facilities for conducting microgravity combustion experiments have been developed. These include the Space Shuttle, Space Lab, sounding rockets, aircraft flying parabolic trajectories, drop towers, and drop tubes. In these facilities it is possible to obtain low gravity conditions for seconds (in drop tubes or towers) to days in the Space Shuttle or Spacelab. In the 1990's another facility will be available for conducting microgravity combustion experiments--the Space Station--and the time will be expanded to months. A major part of the Space Station program is directed at involving the private sector in the U.S. national space program. This is to be accomplished by providing laboratory testing and servicing capabilities to meet the needs of the private sector in the 1990's and 2000's.

Studies to identify future requirements for experiments in Space Station were initiated by NASA through the Lewis Research Center. The first study

involved all types of microgravity experiments and was conducted by Wyle Laboratories (the results were reported in CR-175038, (ref. 1)). The second study concentrated on combustion experiments. This report presents the survey results and recommendations of the study conducted for the Lewis Research Center to determine industry requirements for microgravity combustion experiments aboard Space Station.

Before attempting to establish requirements for conducting experiments in a scientific field as broad and diversified as combustion, it is important to define the various interests in microgravity combustion. One method of categorizing combustion experiments is to segregate the efforts into the classical types of: basic research, applied research, technology development, and applications or product development. The important component of microgravity combustion experiments is basic understanding where the microgravity environment offers ideal, non-convective conditions for combustion experiments. Commercial organizations as well as basic researchers must understand, or overcome as necessary, basic combustion phenomena.

Another method for categorizing combustion experiments is by defining the combustion phenomena involved in the investigation. Discussing experiment requirements using these categories involves defining the details of each experiment. The needs of the commercial sector are not well identified by these categories. A commercial organization will be interested in many of these categories and must understand and/or resolve problems associated with various categories to improve and/or develop a product. For this study the categories of combustion experiments will be defined in terms of physical systems of interest to the commercial sector. The set of experiments will be defined later.

The information needed to establish experimental requirements for combustion studies in Space Station was obtained by contacting various individuals and organizations in the combustion community. A total of 181 individuals from 113 organizations was contacted. The contacts included visits (30 individuals at 12 organizations), phone calls (127 individuals at 83 organizations), and conversations at technical meetings or conferences (24 individuals from 18 organizations). These individuals and organizations were selected as those with potential interest or application for Space Station combustion experiments.

The contacts were equally divided among groups or individuals in three classes:

- (1) Commercial organizations involved in producing a product
- (2) Universities
- (3) Government organizations or organizations totally devoted to performing research

We did not contact all potential users (an impractical task), but by interviewing a large sample from various user areas it is viewed that this survey represents the interests that could be expected for work to be performed 10 or more years in the future. In critical areas or where more specific information was required, second contacts were made to obtain more details to identify design requirements.

The interests of the commercial sector in Space Station combustion experiments can be divided into five interest groups:

- (1) Fire safety for terrestrial applications
- (2) Fire safety in space applications
- (3) Propulsion and power
- (4) Industrial burners
- (5) Pollution control

The first two topics are concerned with the destructive nature of combustion. The third and fourth topics involve the use of combustion in commercial ventures. The fifth category, pollution control, overlaps some of the other areas. Pollution control is a very important area and has several special concerns. Therefore, it is assigned as an additional topic. These topics are used in this study to aid in defining experimental requirements for combustion studies in Space Station. Section III provides a description of the industrial interest, for each of the five interest groups identified above.

Section IV gives a description of the various experiments that have been identified for microgravity studies in Space Station. Six general categories of experimental combustion techniques were identified:

- (1) No flow system with solid or liquid fuel
- (2) Homogeneous mixtures of fuel and air
- (3) Low flow system with solid or liquid fuel
- (4) Low flow system with gaseous fuel
- (5) High pressure combustion system
- (6) Special combustion systems

For each category a representative experiment is defined along with a general description of the experiment and the purpose or objectives of the experiment. The requirements for conducting each category of experiment in Space Station is also provided in this section.

Section V contains discussions aimed at identifying the overall interest in microgravity combustion experiments and the different groups, organizations, individuals, etc., interested in conducting the same types of experiments. For each interest group the relative interest in each type of experiments is assessed.

The overall Space Station facility requirements are provided in Section VI. The requirements that NASA is seeking at this time are estimates of:

- (1) Physical size
- (2) Mass
- (3) Power requirements
- (4) Thermal loads
- (5) Data communications
- (6) Crew involvement
- (7) Servicing
- (8) Safety issues
- (9) Frequency, duration, and number of experiments
- (10) General characteristics of experiments and programs

While these requirements will vary between experiments and experimenters, representative values are provided based on the requirements for individual experiments that are presented in Section III so that Space Station can provide the maximum capability to meet future needs. The requirements for conducting microgravity combustion experiments in Space Station are compared with present plans for Space Station in Section VI. The most severe requirements are discussed in detail in Section VII. A summary of findings follows in Section VIII. Recommendations are given in Section IX.

A list of contacts made during this study, organized alphabetically by organization, is provided in Appendix A. For each contact a cross referencing index is provided to show the interest groups and experiment category determined from the survey to apply to the individual or organization. While these assignments are judgments of the author, and the list is not exhaustive, it is intended that the list will provide an indication of depth and overlap of interests and serve as a catalyst in helping various individuals and groups to work together in planning and conducting combustion experiments on Space Station to obtain maximum benefits.

III. INDUSTRIAL INTEREST IN MICROGRAVITY COMBUSTION EXPERIMENTS

This section contains a description of the needs and applications in combustion that have been identified for each of the interest groups:

- (1) Fire safety for terrestrial applications
- (2) Fire safety in space applications
- (3) Propulsion and power
- (4) Industrial burners
- (5) Pollution control

The objective for this section is to provide the foundation required to judge the needs and type of interest that exist for microgravity combustion experiments.

III.1 Fire Safety for Terrestrial Applications

This interest group is concerned with preventing, detecting, controlling, fighting, and suppressing unwanted fires. Many manufacturers have an interest in this area because of possible fire or explosion hazards. This group includes codes, standards, and regulatory agencies that must provide the information needed to achieve the desired level of fire safety. Also included are the insurance organizations that establish the level of risk involved in fire safety. This group expressed a very strong need for a better understanding of combustion phenomena. Test procedures, standards, codes, etc., that are being used were developed over a long period of time and are very empirical. While these measures are considered adequate it is also realized that a high level of margin has been introduced to insure safety which results in higher costs. This group realizes that a better understanding of the combustion is needed so that new products can be produced safely and economically.

The major specific needs of this interest group concerning microgravity combustion experiments are:

(1) Understanding of and a test method for dust explosions. Microgravity provides an ideal environment for dust-cloud experimentation where a known homogeneous mixture will persist for a long period of time.

(2) Understanding and evaluating fire suppression and/or extinguishing materials. Because of the complexity of the combustion process, there is considerable disagreement over the mechanism of suppression. Microgravity experiments would provide the ideal test conditions needed to determine how the suppressant interacts with the fire. Microgravity would also provide the test bed for evaluating new and different suppressants. Individuals working in this area want to end every microgravity combustion test by introducing a fire suppressant.

(3) Determining signatures of different types of fires. Fire detection is currently based on detecting smoke particles, a temperature rise, or radiant energy. Investigations of fire signatures in the simplified transport environment of microgravity would greatly aid in understanding the needs for fire detection.

(4) Determining ignition requirements for different combustion conditions. Many fire safety features are involved with controlling the ignition mechanisms. While considerable data are available on ignition requirements, the understanding of ignition makes extrapolating the data to new conditions and materials difficult. The simplified energy transport that exists in microgravity will isolate the importance of energy transport in ignition.

(5) Determining fire safety in aircraft, ships, and submarines. Fire safety in these applications have many similarities to the closed environment of Space Station. This analogous knowledge obtained in the idealized environment of space would be of great value in determining the fire safety factors and/or requirements in these terrestrial applications.

III.2 Fire Safety for Space Applications

Fire safety problems in space applications have many unique aspects. Interest was found outside of NASA. Insurance organizations were very concerned about the fire safety aspects in space applications. Lack of knowledge about fires in space limits the ability to determine risk factors. Organizations that would be interested in providing fire detection devices, fire suppression or extinguishment devices, fire fighting equipment, and materials for use in space are limited in the products they can develop because of the lack of data to verify assumed models of microgravity combustion. Hence, all of these groups expressed an interest in microgravity combustion experiments to aid in product development.

Organizations involved in fire safety considerations in space are in a quandry regarding the interest shown in performing microgravity experiments. To be technically competitive each organization must demonstrate an understanding of microgravity combustion and fire safety in space. Therefore, this group has not been very forceful in stating its needs for microgravity combustion experiments. This group has some of the strongest needs in performing microgravity combustion experiments in Space Station, some of which are aimed at solving the immediate problems of Space Station.

Major specific needs of this group involving microgravity combustion experiments are:

(1) Characteristics of fires in microgravity with very low convection velocities encountered in space applications. The major concern is determining the level of convection that will sustain different size fires in microgravity.

(2) Effective fire fighting techniques for space applications. Fire fighting techniques for terrestrial applications rely strongly on gravity to aid in controlling the fire and are not applicable in space. Almost all techniques for fire fighting in space are based on assumptions that cannot be proven or tested without microgravity combustion experiments.

(3) Ignition requirements in space applications. Extensive data, rules, practices, etc., are available for minimizing the onset of fires in terrestrial applications which are not applicable in space. The procedures, materials, etc., that should be used to prevent fires are a major concern for manufacturers involved with space applications.

(4) Influence of flame characteristics on fire detection methods for space applications. Flame detection methods based on using convection flow will not work in space. Optical techniques that can be used for fire detection are very dependent on the flame characteristics. To develop fire detection methods for space requires a general knowledge of flame phenomena and fire characteristics. When a product is developed or is to be used it will be impossible to test and/or demonstrate the product without microgravity combustion experiments.

(5) Effectiveness of fire extinguishing and suppression agents in space. Fire safety problems in space (and special applications for terrestrial use) have provided the impetus to develop new products to control fires. It is important to know and demonstrate how the agents will control real fires in space. This can only be accomplished with microgravity combustion tests of reasonable size and duration.

III.3 Propulsion and Power Applications

This interest group includes those organizations using advanced technology to obtain the maximum efficiency and performance from the combustion processes involved in internal combustion engines, power generating boilers, gas turbines, and rocket engines. Considerable research and technology advancements have been accomplished by or supported by organizations in these fields. This group is looking at microgravity combustion as a means of understanding combustion phenomena to obtain a breakthrough in technology that can lead to improved future products.

The best example of the application of microgravity combustion experiments is that of the investigation of soot formation. In practical systems it is difficult to obtain the detailed information required to understand and control soot formation. Simplified experiments are conducted to obtain data for extrapolation to real conditions. Microgravity combustion provides an ideal test for examining soot formation.

The major needs of this interest group involving microgravity combustion experiments are:

(1) Simplified experiments under the ideal conditions provided by microgravity are needed to obtain the basic understanding of combustion phenomena involved in pollution and soot formation.

(2) High pressure combustion experiments in microgravity to control convection flow so that the formation of soot can be determined. To achieve higher performance many of the applications are relying on higher combustion chamber pressures where soot formation is a major problem.

(3) New technology that can lead to innovative ideas for future development efforts. With a better means of analysis and modeling achieved through microgravity experiments it might be possible, for example, to control fuel preparation in an optimum manner for the desired combustion characteristics.

III.4 Industrial Burners

Industrial burners are used in chemical processing, materials processing, industrial furnaces, incineration, heating, and cooking. In these applications the combustion system is not a major factor in the final product. Changes in the product are made slowly, and reliability is more important than performance.

With industrial burners the major challenges are in making burners for new processes. Generally this is accomplished by modifying existing burners or reapplying the technology. As new technology becomes more predominant the need for improved burner technology is more noticeable. The industry expressed an interest in microgravity combustion experiments but could not provide definitive needs or areas where work is most needed. The most important need now is related to pollution control.

The major needs of this interest group involving microgravity combustion experiments are:

(1) The industry needs more information about the controlling parameters in the formation of NO_x and soot. While they meet the current requirements placed on them for pollution control the industry is concerned that future requirements would be difficult to accomplish with present technology. Most of the burners use gaseous fuel (with simple premixed or bunsen burners) or oil, and any fundamental data obtained with microgravity would help in meeting future requirements.

(2) Understanding combustion phenomena in new types of burners. The industry is starting to use new burners such as infrared and catalytic, which rely on different technology than used previously. Understanding combustion phenomena over a wide range of conditions as would be obtained with microgravity combustion experiments would be of value to the industry in extrapolating old technology and developing new approaches for new types of burners.

III.5 Pollution Control

The industrial burners and the propulsion and power interest groups are directly involved with pollution control problems. These interests are directed at controlling the pollution generated by the combustion process. Pollution is an indication of inefficient or non-ideal combustion. Therefore, to control pollution, it is important to understand the smallest detail of combustion. Microgravity combustion experiments offer this interest group unique opportunities for conducting tests to investigate the details of the combustion process under very controlled conditions. Many of the current microgravity combustion experiments are directed at obtaining this type of information. Indications are that the interest in this area will be maintained and expanded with the opportunities presented by Space Station.

The fire safety group is concerned about pollution generated by some fire extinguishing and suppression materials. Many of these materials generate toxic or harmful combustion by-products. These toxic by-products are also the concern of regulatory agencies that are investigating new materials. Many of the fire fighting materials were selected on the basis of effectiveness without an understanding of how this effectiveness is achieved. Understanding and demonstrating how these materials influence the combustion process will have a large impact on the development of new materials. In addition to the by-products, the fire extinguishing materials themselves often present pollution problems, from discharges in testing or in leakage.

The major needs of this interest group in microgravity combustion experiments are:

(1) Understanding how fire extinguishing and suppressant materials control fires. Different theories are presented by various disciplines in the combustion community. Most theories are based on assumptions that are dependent on fire conditions, type of fire, etc. Information used in designing fire extinguishers is very empirical and is not concerned with how the material controls the fire. Application to new types of fires, fires in space, fires in confined living spaces (like airplanes or submarines), or new materials is difficult. The understanding of combustion phenomena through testing these materials in microgravity combustion experiments is an important goal to this interest group.

(2) This interest group is interested in understanding the mechanism of soot formation in flames. Recent investigations have shown that soot is produced in very localized areas that involve almost all aspects of the combustion phenomena. While the knowledge of soot formation is growing rapidly, critical experiments are needed to determine and control the various competitive processes in flames. Microgravity combustion offers this unique capability. Many of the current microgravity combustion programs are directed at providing a better understanding of soot formation. Because of the complexity of combustion and the concern or interest in controlling soot formation it is safe to say that this interest will extend into the use of Space Station for microgravity combustion experiments.

(3) Another concern is the influence of flame characteristics on NO_x and SO_x production. The chemistry of NO_x and SO_x formation is reasonably well understood for most combustion systems, but means of reducing or controlling

the chemical formation by changes in system design are actively being pursued. This interest group hopes that with improved knowledge from microgravity combustion experiments a major breakthrough in the production of these pollutants could be achieved.

IV. MICROGRAVITY COMBUSTION EXPERIMENTS

After reviewing the interests of various individuals and groups in microgravity combustion, during this survey, it became apparent that the various experiments could be placed into six categories of experiments:

- (1) No flow system with solid or liquid fuel
- (2) Homogeneous mixtures of fuel and air
- (3) Low flow system with solid or liquid fuel
- (4) Low flow system with gaseous fuel
- (5) High pressure combustion systems
- (6) Special burner systems

Each of these categories includes many different experiments that would be dependent on the specific objective of the program and the individual experimenter. However, all of the different experiments within a category would have the same requirements for the Space Station facility. Each experiment would be conducted with some equipment that is unique to that experiment and supplied by the principal investigator, but each experiment could be designed to use the general equipment for that category of experiments.

Almost all groups contacted during this study indicated that the major requirement for microgravity combustion studies on Space Station is to provide a laboratory environment, regardless of the nature of the experiment. Microgravity combustion tests normally require less than minutes to perform an experiment. Setting up the experimental conditions required for the experiment normally requires considerably more time. Without a laboratory environment, for microgravity combustion tests in Space Station, experimenters would need several experimental packages transported into space to obtain the desired test results. Multiple test packages would increase the cost of the experiments and extend the program over a longer period of time. For many experiments using multiple test packages the program could be conducted using other facilities with similar increases in cost and program duration.

The investigators will want to conduct multiple tests over a wide range of conditions. In a typical test program, initial tests would be conducted to calibrate the apparatus. Initial test results would be analyzed, probably with the aid of a computer model, and a new test plan prepared to obtain the maximum information. A test series followed by analysis and another series of tests could be repeated several times, depending on the specific experiment and experimental results. This flexibility is needed to use the full capability of Space Station.

To obtain a laboratory environment Space Station will have to provide a supply of air for use in the experiments and a method for disposing of the exhaust products. The fuel supply would normally be a unique part of each experimental program and carried up to Space Station for that experiment.

Since fire-safety investigators would be using the same apparatus to investigate fire extinguishing and suppressing materials the exhaust product could be toxic, corrosive, and polluting. Therefore the exhaust system will have special design requirements (i.e., stainless steel might be used with special coatings of teflon to withstand the corrosive atmosphere).

All categories of experiments have the same laboratory environment requirement, so they will not be repeated for each experiment. Only unique features will be mentioned. In the following sections a description of the various types of experiments that could be conducted within each category listed above is given. Also included are the objectives of the various experiments and the justification for the use of Space Station. To indicate the level of effort required to conduct experiments in each category the duration of a typical experiment is included. After describing each experiment the Space Station requirements for that category of experiment are provided. Requirements involving data processing and crew involvement are similar for each category and are therefore only listed in the overall facility requirements of Section VI.

IV.1 No Flow System with Solid or Liquid Fuel

This category represents the general class of experiments where small quantities of fuel are placed in a quiescent atmosphere, ignited, and allowed to burn to completion. Various shapes of fuel could be used as indicated below:

- (1) Liquid drop
- (2) Solid sphere
- (3) Array of liquid drops
- (4) Array of solid spheres
- (5) Liquid cylinder (wetted surface)
- (6) Solid cylinder
- (7) Flat liquid (wetted surface)
- (8) Flat or rectangular solid

With each of these shapes a unique symmetry feature is being used to represent an ideal system that can be modeled. The main objective for programs in this experiment class is to compare the results to theoretical models for the purpose of understanding the combustion phenomena and providing a validated model that can be used in other applications. A secondary objective is to observe new phenomena that have not been seen before and/or have not been explained or predicted by theory.

Investigators are interested in this type of experiment as it offers the opportunity to obtain data in a system that matches theoretical models that must include symmetry. With no flow in the system all convective forces disappear and the combustion process is stretched over a greater distance, which permits measurements of the most intricate parts of the combustion phenomena. Microgravity combustion experiments have been conducted with this type of apparatus and are providing a better understanding of the combustion phenomena. The investigators contacted all agreed that more extensive testing is needed to fully realize the benefits of microgravity and that Space Station is the ideal place to do this testing.

A typical program would involve testing over a range of conditions (size of fuel, fuel properties, atmospheres surrounding the fuel, and initial conditions). Each test would involve igniting the fuel and then observing the combustion phenomena to determine temperature and composition profiles in the combustion zone as a function of time. Visual observations would be made to describe the flame shape and speed at different times.

Sketches of possible experimental arrangements for spherical drops or particles and cylindrical or flat fuel samples are shown in figures 1(a) and (b), respectively. The spherical system would normally be a cube with the fuel concentrated around the center of the cube to avoid any wall effects. With cylinders or flat fuel samples the system would be rectangular to allow for a greater length of the burning sample in one direction. To observe the flame phenomena and flame shape, windows are located on all six sides of the equipment. Each experiment would have unique features involving the introduction of the fuel samples. Ignition could be by a point igniter as shown or other means to provide data on ignition requirements.

IV.1a Requirements for no flow experiments with solids and liquids. - The apparatus for spherical drops or particles shown in figure 1(a) has lower requirements than needed for cylindrical or flat samples (fig. 1(b)). Therefore only the requirements for the cylindrical or flat samples are given here.

Physical size	50 by 25 by 25 cm
Frequency of use	60 tests in a program 3 to 4 series of tests Each series has 10 to 20 tests
Maximum test duration	15 min
Minimum test duration	5 sec
Average test duration	1 min
Test series duration	5 hr
Mass experimental apparatus	50 kg
Air	10 kg 10 m ³ at std conditions
Fuel	1 kg 1000 m ³
Power	
Maximum	1 kW
Average	0.1 kW
Energy	0.1 kWh
Thermal load	0.1 kW
Energy, combustion	0.1 kWh

IV.2 Homogeneous Mixtures of Fuel and Air

Experiments in this category involve using homogeneous mixtures of solid or liquid particles in a gaseous atmosphere (aerosols and dust clouds) or a mixture of gases. Truly homogeneous mixtures can only be obtained in micro-gravity since solid and liquid particles do not settle (the major problem in conducting these experiments in a gravitational field). Elimination of convective flows produces the ideal flame that is modeled by various theories. The time element between preparing the mixture and conducting the tests is greatly enhanced, which allows one to make detailed measurements of the mixture before the flame is initiated.

The approach used in these experiments is to prepare the mixture to a prescribed (or measured) set of conditions. An ignition source is used to start the process. Since the flame characteristics are very dependent on the ignition system, fire safety people are interested in varying the ignition to determine what is required to start different types of fires. After ignition a flame or detonation wave travels through the combustible medium. The movement of the flame or detonation front is observed with time along with the spatial characteristics as determined by temperature, pressure, and concentrations. These are normally made with nonperturbing measuring techniques. Some experiments do use thermocouples and/or gas sampling. The flame characteristics are determined over a range of conditions (fuel type, size, atmospheric composition, quantity of fuel, and initial temperature).

A sketch of a possible apparatus to conduct these experiments is shown in figure 2. A long length to diameter tube is usually used for these experiments, with ignition occurring at one end. Different experimenters will prefer different lengths and diameters, but a meter cylinder will meet the needs of most investigators. Windows are located around the cylinder to verify that it is symmetrical. The major measurements are along the cylinder. A mixing or stirring mechanism is used to obtain the desired homogeneity of the mixture before the tests are conducted and then removed.

IV.2a Requirements for homogeneous mixture experimental apparatus. - The specific requirements for the experimental apparatus shown in figure 2 are:

Physical size	100 by 10 cm diameter
Frequency of use	60 tests in a program 3 to 4 series of tests Each series has 10 to 20 tests
Maximum test duration	15 sec
Minimum test duration	0.001 sec
Average test duration	1 sec
Test series duration	5 hr

Mass experimental apparatus	50 kg
Air	2 kg 2 m ³ at std conditions
Fuel	1 kg 1000 m ³
Power	
Maximum	1 kW
Average	0.1 kW
Energy	0.1 kWh
Thermal load	0.1 kW
Energy, combustion	0.2 kWh

IV.3 Low Flow System with Solid or Liquid Fuel

Microgravity experimenters are interested in conducting tests in a low flow environment to obtain a known velocity profile around the fuel and thereby simulate conditions under which most fuels burn (with a convective or forced flow field). The same fuels and shapes indicated for the no-flow experiment apply to this experiment. The main objective for the experimental programs is to compare the results with theoretical models that have the same boundary conditions as used in the experiment and with test conditions that match the assumptions used in the model. New and unusual phenomena that have not been observed previously or predicted by theory could also be investigated with this class of experiment.

A typical program would involve testing over a range of flow conditions with different geometrical sizes of fuel, fuel properties, and flow composition. Each test would involve placing the fuel sample in the test chamber, establishing flow conditions, and then igniting the fuel. Data would be taken as the flame establishes a steady state condition. If sufficient fuel is available the flow field could be changed during the test sequence. Major measurements are temperature and composition within the flame and observations of the flame to determine shape and burning rates. Some thermocouple measurements could be made in the fuel sample, flame zone, and flow field. Some investigators would want to remove gas samples from strategic locations in the flame.

Sketches of possible experimental arrangements for spherical drops or particles and cylindrical or flat fuel specimens are shown in figures 3(a) and (b), respectively. The spherical droplet system could be small in cross section because the drops and particles do not occupy much space. Sufficient length must be allowed to complete the burning process and allow the flow to stabilize before reaching the fuel. To observe the flame phenomena and shape of the flame, windows are located on the four walls for the entire straight portion of the test section. Heating elements are located in the corners of the rectangular test section to provide radiant heating of the fuel if required to simulate a large flame.

Many of the tests with solid samples of reasonable size would require minutes to conduct. Therefore it would be impossible to conduct these tests in

drop towers or on airplanes. Therefore this is a class of testing that needs the capabilities of Space Station to conduct. Since most combustion applications involve flow, the low flow experiment is a better representation of actual combustion phenomena and of most interest to commercial organizations. This experimental system is of the most interest to organizations and individuals contacted in this study.

IV.3a Requirements for low flow with solid and liquid fuel experiments. - For the two different pieces of apparatus shown in figures 3(a) and (b) the apparatus for testing two-dimensional fuel samples has higher requirements than the apparatus for testing drops or particles. Therefore, only the requirements for the two-dimensional fuel sample experiments are given here:

Physical size	100 by 25 by 25 cm
Frequency of use	60 tests in a program 3 to 4 series of tests Each series has 10 to 20 tests
Maximum test duration	15 min
Minimum test duration	5 sec
Average test duration	1 min
Test series duration	5 hr
Mass experimental apparatus	50 kg
Air	100 kg 100 m ³ at std conditions
Fuel	10 kg 10 000 m ³
Power	
Maximum	2 kW
Average	0.5 kW
Energy	0.5 kWh
Thermal load	0.5 kW
Energy, combustion	1 kWh

IV.4 Low Flow System with Gaseous Fuels

Low flow microgravity experiments with gaseous fuel are conducted to investigate combustion phenomena in the following configurations:

- (1) Bunsen diffusion flame
- (2) Premixed flat flame
- (3) Opposed jet diffusion flame
- (4) Cylindrical diffusion flame

All configurations require a modest flow of air (or oxidizing environment) and gaseous fuel. The air and fuel are either mixed to study premixed flame phenomena or introduced separately to study diffusion flames. These

flame configurations are very good representations of many commercial combustion systems. Microgravity combustion experiments eliminate the secondary convective flow which distorts the flame and/or produce quenching effects that are difficult to model theoretically.

Programs generally require testing over a range of air and fuel flows, burner size, and fuel properties. A given test involves starting the air and fuel, followed by an ignition. The flame is allowed to stabilize and measurements of temperature, composition, and flame shape are made with nonperturbing measuring devices. Occasionally thermocouples are used and gas samples are frequently taken in the exhaust products to determine concentrations of intermediate or byproduct species. Flow rates are changed to a new condition and the process is repeated. Usually the test is continued until a blow out (flame extinguishment) point is determined.

A sketch of possible apparatus used with the bunsen or premixed burner experiment is shown in figure 4(a). Windows are located around the flame to permit viewing and measuring from four sides. Apparatuses for the opposed jet diffusion flame and cylindrical diffusion flame are illustrated in figures 4(b) and (c). These systems consist of cylindrical reactors with the fuel entering into the center of the cylinder. Air enters from the center or outer diameter. Exhaust products flow out of the apparatus from the outside diameter. Windows are located on both ends of the cylinder to permit measuring and viewing of the flame profile. These two burners provide the ideal cylindrical symmetry desired in modeling flames and they stretch the combustion process to facilitate detailed measurements required within the flame.

A typical test program would involve setting up the burner and adjusting the flow-burner system to obtain the desired flame conditions. After the burner is adjusted the test series involving air and fuel flow is conducted with different fuels, burner size, or flow conditions (i.e., turbulence levels). Measurements involve temperature and composition surveys in the flame, flame shape, and flow conditions at which the flame extinguishes. While the actual time to make measurements at one series of flow conditions is seconds the duration of a normal experiment, involving setup and changing flow conditions, may be an hour. With drop towers or aircraft flights, it is impossible to adjust the flame at the beginning of the test and obtain a series of tests at different flow conditions without interrupting the experiment. These are important considerations that can easily be achieved in Space Station.

IV.4a Requirements for low flow with gaseous fuel experiments. - Of the different pieces of apparatus to test two-dimensional diffusion burners, opposed jet burner, and cylindrical diffusion burner shown in figures 4(a) to (c) the two-dimensional diffusion burner system has the highest requirements; only it will be described here.

Physical size	50 by 15 by 15 cm
Frequency of use	60 tests in a program 3 to 4 series of tests Each series has 10 to 20 tests

Maximum test duration	5 min
Minimum test duration	5 sec
Average test duration	1 min
Test series duration	2 hr
Mass experimental apparatus	50 kg
Air	100 kg 100 m ³ at std conditions
Fuel	10 kg 30 m ³ at std conditons
Power	
Maximum	1 kW
Average	0.1 kW
Energy	0.1 kWh
Thermal load	0.1 kW
Energy, combustion	1 kWh

IV.5 High Pressure Combustion Systems

Many combustion systems operate at high pressures (greater than 1 MPa or 10 atm) and hence are difficult to model and simulate at low pressures. Space Station therefore may offer the opportunity to investigate these systems through the simplification of the non-convective environment.

Experiments to investigate high pressure phenomena in combustion are very specific in the techniques used to create the high pressure. These investigations generally involve high temperatures and pressures which make the design of equipment very difficult. Generally the experiment involves the transient behavior of the combustion process as it moves from ignition to steady state, which means the time period to conduct the experiment is very short. These investigations require using ingenious techniques to achieve the desired combustion conditions, methods which certainly will be improved in the next 10 to 20 years.

The major problem with doing microgravity combustion experiments at high pressure is the safety considerations involved with high pressure phenomena. The special equipment built for these experiments is designed to accommodate the highest possible pressure. An enclosure surrounding the special test apparatus will also be used to prevent any leaks from entering the Space Station environment.

IV.5a Requirements for high pressure combustion experiments. - As described there will be special pieces of equipment that will be designed for accomplishing the specific objectives of the program. Based on other high pressure experiments that have been conducted and a knowledge of those that might be proposed, the following is a list of requirements that should cover the majority of experiments that might be proposed in this area.

Physical size	75 by 50 by 50 cm
Frequency of use	30 tests in a program 2 to 3 series of tests Each series has 10 to 20 tests
Maximum test duration	10 sec
Minimum test duration	0.1 sec
Average test duration	1 sec
Test series duration	4 hr
Mass experimental apparatus	100 kg
Air	1 kg 1 m ³ at std conditions
Fuel	0.1 kg 10 m ³ at std conditons
Power	
Maximum	10 kW
Average	1 kW
Energy	1 kWh
Thermal load	1 kW
Energy, combustion	0.01 kWh

IV.6 Special Combustion Systems

In any research program as broad as combustion, investigators will always want special systems that are unique to that investigation. In this survey three such systems were identified:

- (1) Fire safety modeling of space station
- (2) Standard dust explosion tester
- (3) Fluidized bed experiments

Each of these will be defined separately to indicate the types of requirements that would be needed in Space Station.

IV.6a Fire safety modeling of Space Station. - Modeling of Space Station to determine fire-safety requirements evolves from the use of models for normal-gravity fires to predict how fires would ignite and spread in real conditions. Standards and fire-control organizations have developed standard methods for conducting these tests at 1/10 scale. With the use of computer models it is then possible to predict the fire characteristics and safety requirements for actual fires. These techniques have been developed and verified for normal-gravity fires. In microgravity most of the controlling parameters (convection terms) are absent, and it is difficult to extrapolate the data and/or computer model analyses to this environment.

The fire-safety group is very interested in conducting experiments in a 1/10 scale model of Space Station to determine and/or verify the fire safety

aspects of fires in space. A representation of such a model is shown in figure 5. Scaling a typical module of Space Station is accomplished by using a box with short sections of the connecting links between modules. A typical test includes simulating whatever flow would be expected in the module due to movement of the astronauts and ventilation. Modeling would include the influence of equipment in Space Station as indicated by the control panel in figure 5. The spread of typical fires would be observed through windows. Temperatures are measured throughout the module (including surfaces) by thermocouples or nonperturbing measuring devices, velocities are measured by probes or nonperturbing measurements, and gas samples are taken at various positions to determine the composition of the combustion products.

Tests are performed using various types of ignition systems, initial burnable material, shape of the module, and initial environmental conditions. The data are analyzed with the use of computer models and conditions that could be more severe fire hazard conditions are predicted. These more severe conditions are then retested and compared to the predicted results. The computer model is then used to determine fire safety requirements for the actual conditions expected in Space Station or any other microgravity field. A typical experiment could require minutes to hours (if a smoldering fire was started) to complete.

Modeling tests of fire safety in Space Station can best be accomplished in Space Station. Because of the size requirements and test times the experiments cannot be conducted in drop towers, drop tubes, or airplanes. Space Shuttle could be used for an individual test, but it would be very costly to obtain the series of tests required to validate the models. Tests using sounding rockets could be used to obtain data for fires that spread rapidly (minutes), but it would be impossible to obtain the slow burning, smoldering fire data that is most needed for space applications.

IV.6b Requirements for fire-safety modeling of Space Station. - The requirements for the apparatus to perform fire-safety modeling experiments of Space Station are not well defined. From discussions with the modelers and a general view of Space Station dimensions the following requirements based on the model shown in figure 5 are reasonable estimates:

Physical size	90 by 50 by 30 cm
Frequency of use	30 tests in a program 2 to 3 series of tests Each series has 10 to 20 tests
Maximum test duration	1 hr
Minimum test duration	10 sec
Average test duration	10 min
Test series duration	4 hr
Mass experimental apparatus	50 kg
Air	100 kg 100 m ³ at std conditions
Fuel	1 kg 1000 m ³ at std conditons

Power	
Maximum	1 kW
Average	0.1 kW
Energy	1 kWh
Thermal load	0.1 kW
Energy, combustion	1 kWh

IV.6c Standard dust explosion tester. - The terrestrial fire safety group is very interested in conducting tests in microgravity using the "Standard Dust Explosion Tester." Currently two different dust explosion testers are used by the industry to determine explosion hazards and safety requirements with different types of dusts. The two testers do not give the same results, and the industry is worried that neither tester is providing the data required to identify true explosion hazards and safety requirements.

The major unknown in these testers is the composition of the dust mixture when the explosion is initiated. In both units a known quantity of solid material (dust) is introduced into the tester. Different techniques are used to produce the dust-air mixture. Because of gravity and the limited time to produce the mixture before settling occurs in normal-gravity, it is impossible to determine the uniformity of the mixture and/or composition of the mixture. Both of these parameters influence the explosion hazard and safety requirements.

Experiments with the no flow homogeneous experiments described in Section IV.2 will be of great value to the fire safety interest group. However, the industry needs to calibrate the standard tester in order to correlate the findings with previous techniques and experience. On the basis of the microgravity test results, a new "Standard Tester" could be developed which the industry would want to verify in microgravity.

IV.6d Fluidized bed. - During the survey it was mentioned that fluidized bed testing might be desired to help understand fluidized bed phenomena of interest to the power group. It is conceivable that sometime in the future this group would be interested in conducting such experiments in Space Station to lower the velocity required to fluidize the bed. This permits testing in a very different Reynolds number range, etc., and could uncover new phenomena that would enhance the combustion process and possibly permit the development of a new type of burner. A normal test would require hours to come to equilibrium and observe the different transient phenomena that occur with fluidized beds.

V. DISCUSSION OF INDUSTRIAL INTERESTS AND EXPERIMENTS

To determine the future requirements for conducting microgravity combustion experiments on Space Station, it is necessary to understand the relative interests in the various types of experiments. Each experiment category is not limited to one interest group, and each interest group could be involved with several types of experiments.

Table I shows the relative interest in the six categories of experiments:

- (1) No flow with solid and liquid fuels
- (2) Homogeneous mixtures of fuel and air
- (3) Low flow with solid and liquid fuels
- (4) Low flow with gaseous fuel
- (5) High pressure combustion
- (6) Special combustion systems

Table I also shows the relative interest for each of the interest groups:

- (1) Fire safety for terrestrial applications
- (2) Fire safety for space applications
- (3) Propulsion and power
- (4) Industrial burners
- (5) Pollution control

An assessment of the relative interest for future development has been given to each experiment in the Table I matrix as follows:

- "High" The interest group is very involved in these experiments and has a definite need for technology derived from these experiments.
- "Medium" Interest group shows a definite interest for being involved in these experiments and has an interest in technology derived from these experiments.
- "Low" Interest group has a minor but identifiable interest in the experiments and has a general interest in technology derived from these experiments.
- "None" Interest group has no specific needs for space experiments but may have a general interest in results.

The liquid and solid fuel experiments involving no or low flow had the most "High" interest ratings. Homogeneous mixtures and gaseous fuel experiments had mostly "Medium" and "Low" interest ratings. High pressure combustion systems and special combustion systems had mostly "None" interest ratings with a few exceptions of "Medium" and "High" interest. Requirements for microgravity combustion studies in Space Station should therefore emphasize liquid and solid experiments and not be overly concerned about the high pressure experiments and special types of burners.

The broad interest in certain experiment categories as shown in table I indicates that efforts should be made to obtain the data required by the different interest groups with the same experiment. Sharing an experiment and/or data raises the question of proprietary data. None of the individuals or organizations contacted expressed a concern about proprietary data as all were interested in basic understanding which is not considered proprietary. An experimental program should not be structured to meet the needs of only one group, experimenter, etc. An example of the desirable approach would be an experiment involving the burning of flat sheets of paper to determine the burning rate at various flow rates in microgravity versus normal gravity. This experiment needs an ignition source, and the fire safety groups and investigators involved with ignition would like to see this experiment conducted with different levels of ignition energies and possibly different types of igniters.

Similarly for fire detection technology the experiment should investigate the radiation levels exhibited by the fire, including the frequency spectrum. Pollution control groups would want to know contamination levels in the combustion products, where contamination is formed and what mechanism controls contamination. Finally at the conclusion of the experiment, the experiment should investigate requirements to extinguish or control the fire. One approach would be to coat part of the paper with fire suppressing material or add a fire extinguishing agent (water, CO₂, halogens, etc.) to see the relative effects of these materials on the fire. This example illustrates the ability of one experiment to meet the needs and interests of different groups. Similar examples can be given for other experiments and other interest groups.

By combining interest groups into one experiment the overall cost in time and monies to obtain the same data would be reduced significantly. One experiment, facility design, safety review, and principal investigator could meet the needs of all interest groups. The combining of experiments would also increase the value, interest, and priority given to one experiment. In discussing experiments with individual experimenters it became obvious that most experimenters are unable, not interested, or unwilling to commit the time and monies required to conduct a microgravity experiment in a manned space vehicle, providing another strong argument for combining experiments.

The need to combine microgravity combustion experiments for Space Station introduces an important requirement. Space Station must devise a way by which experimenters get together to plan combined experiments before a specific program is defined. This planning can be accomplished by workshops in which various groups discuss needs and approaches to derive a plan by which various needs can be accomplished with the same hardware. Formation of formalized NASA/industry/university technical working groups to implement the plans would also aid achieving combined microgravity combustion experiments.

VI. SPACE STATION FACILITY REQUIREMENTS

To meet all the safety requirements of Space Station the individual experiments discussed in Section IV would have to be contained within a separate facility as shown in figure 6. This is to assure that any leaks, spills, failures, etc. will not permit flammable fuels or toxic materials to contaminate Space Station. The facility would fit in a double rack as currently envisioned for Space Station. The facility would contain standard connections for supplying air and removing exhaust products. Controls, standard instrumentation, and data recording would be integral parts of the combustion facility. The unit shown in figure 6 is large enough to contain each experimental apparatus described in Section IV. A major limitation in space experiments is the availability of electrical power. Only the high pressure experiment indicated a large power requirement (10 kW maximum). The overall facility requirements, excluding the power for the high pressure experiment, are:

Physical size	1 by 1 by 1 m
Frequency of use	3 to 4 times for 2 to 3 days each for each experimental program

Weight	100 kg (estimated)
Power requirements	2 kW (maximum)
Energy requirement	0.5 kWh (maximum)
Thermal loads	0.5 kW (maximum)
Combustion energy	1 kWh
Servicing	Would be stored and used only as required to meet individual experiment needs
Crew involvement	Trained technician to conduct experiment and set up facility or install apparatus
Data communications	Main requirements are for a high speed video system and the laser system to measure temperature and concentration
Safety	Designed to protect Space Station within two vessels to prevent leaks, etc.
General characteristics	Windows on all six sides for viewing. One or two removable sides to permit installation of experiment. Standard connections for air supply, instrument cables, controls, exhaust system, gas sampling lines. Storage inside for fuels, fire extinguishing material, waste fuel.

The general construction requirements for the facility are minimum. Expected pressures are low as the test apparatus will provide containment of the fuel, combustion, and combustion products. Because the facility will not be used continuously it is assumed that between test periods it will be stored and moved out into a test area. During tests the facility should be accessible on all six sides to permit maximum flexibility to data taking and observations. Symmetry is a key factor in most of the test programs discussed above so it is important that observations can be made to demonstrate this symmetry. Combustion experiments would be conducted by placing the different pieces of equipment required to contain each experiment inside the combustion facility.

VII. ACCOMMODATION IN SPACE STATION

The facility requirements for conducting microgravity combustion experiments in Space Station given in Section V indicates that they are compatible with present plans for Space Station. The most severe requirement is the disposing of combustion products.

VII.1 Disposing of Combustion Products

Collection of the combustion products can be accomplished easily, as all the experiments are contained within two vessels (experimental apparatus surrounded by the facility). The maximum volume of combustion gas generated in a series of tests (5 hr duration) would be 40 m³ at standard conditions (possibly 100 actual m³ at average combustion gas temperatures). Methods for effectively storing this gas for future use and disposal would have to be provided. Different means for disposing and/or reusing this gas can be considered and would have to be studied to determine the most effective means of meeting this requirement.

Disposing of the combustion gases would be further complicated with the use of fire suppressants and extinguishing agents. As discussed in Section IV the fire safety interest groups would want to use these materials to determine how they control fires. Unfortunately, many of the extinguishing agents create toxic and/or corrosive combustion products which present special safety and handling problems. Some of the combustion products are so corrosive that stainless steel must be protected by coating the components with teflon.

VII.2 Providing a Laboratory Environment

A major requirement for microgravity combustion experiments in Space Station is to provide a laboratory environment where a series of tests can be accomplished. Associated with this requirement is the ability to change the test matrix and test procedures. To maintain the safety and control required for a manned--expensive--vulnerable Space Station means that procedures will have to be developed to permit experimenters to change test conditions within a range of conditions as compared to specified conditions that are approved for self-contained experiments. NASA will have to address this problem in order to attract industrial and commercial interests into using the Space Station for microgravity combustion experiments.

VII.3 General Use Diagnostic Equipment

Several pieces of diagnostic equipment have been identified for development for use in microgravity combustion experiments. All of them should be external to the combustion experiment to maximize the ability to make measurements at various locations in the experiment. Being external also means that the diagnostic equipment does not have to be involved with the development of an experiment.

As part of the survey of equipment for microgravity combustion experiments on Space Station the following diagnostic equipment requirements were identified.

Video system:	
Pixels	200 by 200 to 400 by 400
Resolution	5 to 10 μ m
Image size	1 to 200 mm
Exposure time	10 ⁻⁹ to 10 ⁻³ sec

Focal length	5 to 100 cm
F number	2 to 30
Temperature measuring system (laser):	
Accuracy	25 to 100 °C
Range	200 to 3,000 °C
Size of element	
Diameter	0.3 to 1.0 mm
Length	3 to 10 mm
Time	10 ⁻⁶ to 10 ⁻³ sec
Species concentration measuring system (laser and/or mass spec):	
Size of element	
Diameter	0.3 to 1.0 mm
Length	3 to 10 mm
Time	10 ⁻⁶ to 10 ⁻³ sec
Accuracy	
For major reacting species, (CO ₂ , H ₂ O, hydrocarbons, etc.)	10 percent over range of 100 to 10 000 ppm
Intermediate species, (O ₂ , OH, H ₂ , No. 2, etc.)	20 percent over range of 10 to 1,000 ppm
Toxic species, (From chlorides, cyanides, etc.)	10 percent over range of 0.1 to 10 ppm
Dust particles	10 percent over range of 10 to 1,000 μm

Development of a video system, nonperturbing temperature measuring system, and species concentration measuring system should be considered as equipment being developed for Space Station rather than for microgravity combustion experiments. For example the requirements specified for a video system should meet those of almost every experiment planned for Space Station. A video system could also be used for observing Space Station activities. Similarly temperature measurements are very common requirements in most experiments. Therefore a portable laser temperature measuring system would be very useful in other experiments.

The species concentration requirements for low level toxic species (normally accomplished by a mass spectrometer) would be a requirement for inspections in Space Station. The mass spectrometer is about the most reliable method for finding leaks, pollution problems, etc. Therefore, a portable mass spectrum or one that could analyze samples obtained throughout Space Station would be invaluable in maintaining a safe environment. Laser measurements of species concentrations could be used in other experiments and for measuring inerts or quality of the gaseous environment in Space Station. The instrument would be invaluable in determining if leaks of inert or other gases were present in Space Station.

VIII. SUMMARY OF FINDINGS

Definitions of experiments and requirements for future microgravity combustion experiments were obtained from consultations with university, government, and private research groups. Some of the survey group had individuals currently involved with microgravity experiments, but many are not involved

and would like to become involved in future programs. From an assessment of this survey the following findings were made.

1. The commercial sector has a definite interest and need to conduct certain microgravity combustion studies in Space Station, but the commercial sector has difficulty in defining experiments and requirements resulting from these interests and needs. The main motivation for these interests are in using microgravity as an idealized low-convection environment for experiments aimed at a better understanding of the combustion process for application and development of new and improved products.

2. The interests of the commercial sector cover all aspects of combustion, from ignition to extinguishment, and involve all types of organizations, from insurance and safety codes groups interested in fire safety to manufacturers of combustion devices. Each has unique interests but is after similar results and understanding.

3. Many investigators, interest groups, organizations, etc., want to perform experiments of the same type, all of which can be accomplished in the same program with one set of equipment. Equipment requirements to meet the majority of the need for future experiments are simple. A general combustion facility with various pieces of experimental apparatus within the facility can be used to meet different requirements. Five to ten pieces of apparatus should meet the majority of future needs.

4. Individual organizations or investigators have insufficient resources or interest to undertake a microgravity combustion study alone. This includes the total time from inception of the program to completion as well as the physical resources for development of equipment to perform the experimental investigation. A commercial organization, especially, has difficulty initiating and supporting a program that will require 5 to 10 years to complete.

5. Everyone interested in microgravity combustion experiments expressed a desire to have a laboratory environment in which a series of experimental tests can be performed. Changes in the test plan, matrix, and procedures would be made on the basis of the experimental data obtained. A series of tests would be made with time between series used to examine the data and compare results to theoretical predictions.

6. Conducting a series of tests requires that a means be provided to collect and dispose of the products of combustion. These products may be toxic and/or corrosive which could create severe problems in developing a system to meet this requirement.

IX. RECOMMENDATIONS

The following recommendations, directed at obtaining the maximum involvement of the private sector in Space Station combustion experiments, were derived on the basis of the survey results and conclusions drawn from these results.

(1) Design and develop a combustion facility, with a laboratory environment, so that all categories of combustion test apparatus can be used to conduct a series of tests. The laboratory environment would provide time between test series to analyze data, compare the data to theory, and then change the next test series. The combustion facility would have standard connections for air supply, exhaust of combustion products, windows, instrumentation cables, and controls.

(2) Develop a technology plan that has the commercial sector INVOLVED IN EVERY EXPERIMENT. The involvement should begin with the initial planning of the experiment. This involvement can be accomplished by having workshops to indoctrinate various groups on needs and interests of the commercial sector while explaining the types of experiments that are being considered.

(3) Provide support (development funds, flight expenses, etc.) for those experiments or programs that include tests to meet the needs of several groups and have both financial and personnel commitment of different groups and organizations, of which one must be from the private sector. This will minimize the cost in time and monies to develop and conduct the experiments while maximizing the value and interest in the experiment.

(4) Provide modular diagnostic units, external to the combustion facility, for measuring and recording the combustion phenomena. The modular units can be used for many different experiments (including non-combustion experiments) and for Space Station operation. This will minimize the development time and costs of individual pieces of equipment to conduct different experiments and will minimize the weight and volume of the equipment that must be transported to Space Station.

APPENDIX A - CONTACT LIST FOR COMBUSTION INDUSTRY REQUIREMENTS FOR
SPACE STATION SURVEY WITH AREAS OF INTEREST AND EXPERIMENT INTERESTS

Code for Areas of Interest:

FS Fire Safety for Terrestrial Applications
 SP Fire Safety for Space Applications
 PP Propulsion and Power
 IN Industrial Burners
 PC Pollution Control

Code for Experiment Interests:

1 No Flow System with Liquid or Solid Fuels
 2 Homogeneous Mixtures of Fuel and Oxygen
 3 Low Flow System with Solid or Liquid Fuel
 4 Low Flow System with Gaseous Fuels
 5 High Pressure Combustion Systems
 6 Special Burner Systems

Organization Address Name Title Telephone Number	Interests
ADVANCED FUEL RESEARCH INC. P.O. Box 18343 East Hartford, Conn. 06118 Dr. Peter Solomon President (203) 528-9806	PP,PC - 3
AEROJET TECHSYSTEMS CO. P.O. Box 1322 Sacramento, CA 95813 Marvin Young (916) 355-2064	PP - 5,3
AEROJET PROPULSION RESEARCH INSTITUTE P.O. Box 13502 Sacramento, CA 95853-4502 Dr. David T. Pratt (916) 355-3872	PP - 5,3
AEROSPACE CORP. P.O. Box 92957 Los Angeles, CA 90009 Dr. Norman Cohen M5/747 (213) 336-7427 Ron Cohen M5/754 (213) 336-5946	PP - 3 PP,SP,FS - 3,1,2

A.F.O.S.R. / NA
Bolling AFB
Washington D.C. 20332
Dr. Julian Tishkoff PP,SP,FS, - 3,1,5,2,6
(202) 767-4935

AEROCHEM CORP.
P.O. Box 12
Princeton, NJ 08542
Hartwell F. Calcote FS,PC,IN - 4,1,2
President

ALUMINUM COMPANY OF AMERICA
Alcoa Building
Pittsburgh, PA 15219
Mr. T.L. Carter IN
(412) 553-4545

ALZETA CORPORATION
2343 Calle Del Mundo
Santa Clara, CA 95054
Bob Kendall IN,PC,PP - 4,3
(408) 727-8282

AMOCO OIL COMPANY
P.O. Box 400
Naperville, IL 60566
Dr. Keith W. McHenry Jr IN
V.P., Research & Dev. Dept.
(312) 420-5111

APPLIED PHYSICS LAB
John Hopkins Rd.
Laurel, Maryland 20810
Robert Fristrom FS,PC,PP - 2,3,1
(301) 953-6221

ARMSTRONG WORLD INDUSTRIES INC.
Research & Development Dept.
P.O. Box 3511
Lancaster, PA 17604
James L. Jackson FS - 1

U.S. ARMY BALLISTIC RESEARCH LAB
SLCBR-IBD
Aberdeen Proving Ground
Maryland 21005
Martin Miller PP - 2
(301) 278-6156

ATLANTIC RESEARCH CORPORATION

5390 Cherokee Avenue
Alexandria, VA 22312

E.T. McHale PP,PC,FS - 2,1
(703) 642-4088
Merrill King PP,FS - 2,1
(703) 642-4217

BABCOCK & WILCOX

1562 Beeson Street
Alliance, OH 44601

Tom Modrack PP,PC, - 6,3
(216) 821-9110

BATTELLE

Columbus Laboratories
505 King Ave.
Columbus, OH 43201

Ronald A. Cudnik IN,FS - 4,1,3
Manager, Energy & Thermal Tech.
(614) 424-7316
Jim Saunders FS,IN - 1,2,4
(614) 424-3271
Jim Reuther FS,IN - 2,1,3
(614) 424-7916
Bob Giammar PP,PC,IN - 3,1,4
Manager, Combustion Tech.
(614) 424-7701

THE BOC GROUP INC.

100 Mountain Ave.
Murray Hill
New Providence, NJ 07974

N.W. Marinelli IN
(201) 771-6311

BRIGHAM YOUNG UNIVERSITY

Provo, Utah 84602

Dr. L. Douglas Smoot PP,PC,IN - 3,1
270 Clyde Building
(801) 378-4326
Dr. Merrill Beckstead PP,PC - 5,4,3,1
Chemical Engr. Dept.
(801) 378-2586

BROOKHAVEN NATIONAL LAB

Bldg. 120
Upton 1, NY 11973

C.R. Krishna FS,IN - 1,3
(516) 282-4025

BROWN UNIVERSITY

Div. of Engineering

Box D

Providence, Rhode Island 02912

Prof. Merwyn Sibulkin FS,SP,IN - 3,1,2

Mechanical Engr.

(401) 863-2867

BUREAU OF MINES

Pittsburgh Research Center

P.O. Box 18070

Pittsburgh, PA 15236

Dr. Robert F. Chaiken PP,PC,IN - 1,3,4

(412) 675-6541

Dr. Martin Hertzberg FS,PP,PC - 4,2

(412) 675-6625

Phil Goldberg FS,PP,PC - 3,4,1

(412) 675-5882

CABOT CORPORATION

Concord Rd.

Billerica, MA 01821

Dr. Jim Bittner IN

General Manager,

Carbon Black Technology Div.

(617) 663-3455

UNIVERSITY OF CALIFORNIA BERKELEY

Dept. of Mechanical Engineering

Berkely, California 94720

Prof. A.K. Oppenheim PC

(415) 642-0211

Prof. Robert F. Sawyer PP,PC - 3,1

(415) 642-5573

Prof. John W. Daily PC,PP - 3,2

(415) 642-0238

Prof. A. Carlos Fernandez Pello FS,PC,PP - 1,3,2

(415) 642-6554

UNIVERSITY OF CALIFORNIA DAVIS

Department of Mechanical Engr.

Davis, California

Prof. C.K. Law PP,PC,IN - 3,1,4,2

(916) 752-8928

Ian Kennedy IN - 2

UNIVERSITY OF CALIFORNIA IRVINE

School of Engineering

Irvine, CA 92717

Prof. William Sirignano PP,PC - 1,3,4

Office of the Dean

(714) 856-6002

UNIVERSITY OF CALIFORNIA LaJOLLA
LaJolla, CA 92093
Prof. Abe. L. Berlad FS,SP - 2,1,4,3
(619) 756-4458

CALIFORNIA INSTITUTE OF TECHNOLOGY
Pasadena, CA 91125
Dr. Anatol Roshko PP
(818) 356-4531

CARNEGIE MELLON UNIVERSITY
Pittsburga, PA 15213
Dr. Edward S. Rubin IN
Director, Center for Energy Studies
(412) 268-2491
Prof. Norman Chigier PP,IN,PC - 3,1
Dept. of Mechanical Engr.
(412) 268-2498

CASE WESTERN RESERVE UNIVERSITY
Mechanical & Aerospace Engr.
Cleveland, OH 44106
Prof. James S. Tien FS,PC,PP - 3,4,1
(216) 368-4581

CHEVRON RESEARCH COMPANY
576 Standard Ave.
P.O. Box 1627
Richmond, CA 94802-0627
Dick A. Kohler IN
(415) 620-4048

CIBA GEIGA
Toms Rivers, NJ
Tom Hoppe FS - 1,3,6
(201) 349-5200

THE CLOROX COMPANY
P.O. Box 493
Pleasanton, CA 94566
Robert C. Cook IN
Manager, Grill Products
(415) 847-6226

UNIVERSITY OF COLORADO
Boulder, CO 80309
Dr. Melvyn C. Branch PP,PC - 1,6,3
(303) 492-6318

COMBUSTION POWER COMPANY
 1020 March Rd., Suite 100
 Menlo Park, CA 84025
 Dr. Jerry Cooper PP - 6
 Manager, Process Engr.
 (415) 324-4744

UNIVERSITY OF CONNETICUT
 Dept. of Mechanical Engr.
 Storrs, Conneticut 06268
 Prof. Eli. K. Dabora PP,IN,FS - 2,1
 (203) 486-2415

CORNELL UNIVERSITY
 Ithaca, NY 14853
 Prof. Fred Gouldin PP,IN,PC - 3,4
 Upson Hall

CUMMINS ENGINE COMPANY
 Columbus, IN 47201
 Dr. S.M. Shahed PP,PC - 5,1,3
 (812) 377-7330

D.O.E.
 Gaithersburg, Maryland
 Chuck Garrett FS,PP,PC - 1,3,4
 (301) 353-2819
 Al Laufer PC,PP - 4,2
 (301) 353-5820

DOW CHEMICAL
 Analytical Lab
 Midland, Michigan 48674
 Bruce Powers FS,IN - 1,3,5
 Manager, Reactive Chemicals Testing
 (517) 636-1000

DREXEL UNIVERSITY
 MEM Dept.
 Philadelphia, PA 19104
 Prof. A.M. Mellor PP,IN - 1,2,3

E.I. DuPONT DeNEMOURS CO.
 Haskill Lab
 P.O. Box 50, Elkton Road
 Newark, Delaware 19711
 Rudolph Valentine IN
 (302) 366-5315

E.P.A.
 401 M St., SW
 Washington D.C. 20460
 Steven Anderson PC - 1,2,3,4
 MS ANR 445
 (202) 475-9403

ELECTRIC POWER RESEARCH INST.

3412 Hillview Ave.

P.O. Box 10412

Palo Alto, CA 94303

Jim Kesselring IN,PP,PC - 4,2
(415) 855-2000

Shelten Ehrlich PP,PC - 4,2
(415) 855-2444

Dr. John Stringer PP,PC - 2,4
(415) 855-2472

ETHYL PETROLEUM ADDITIVES

125 LAFAYETTE

St. Louis, MO 63104

Aubrey Burrows PP,PC
(314) 421-3930

EXXON RESEARCH & ENGINEERING

Route 22 East

Ammendale, NJ 08801

Dr. Anthony M. Dean IN,PC
(201) 730-2727

P.O. Box 101

Florham Park, NJ 07923

Dr. Charles Benson PC,PP - 4,3
(201) 765-1250

FACTORY MUTUAL RESEARCH

1151 Boston Providence Turnpike

Norwood, Mass. 02062

John DeRis FS,SP,PC - 1,3,4,6
(617) 762-4300

Robert G. Zalosh FS,SP - 6,1,3,2
Asst. Mgr., Applied Research

FENWALL INC.

400 Main St.

Ashland, Mass. 01721

Bill Garvey FS,SP - 1,3,4
Protection Systems Div.
(617) 881-2000

FIKE CORPORATION

704 South 10th St.

Blue Springs, Missouri 64015

Dr. Eian Swift FS,SP - 2
Technical Director
(816) 229-3405

UNIVERSITY OF FLORIDA
 Combustion Laboratory
 Gainesville, FL 32611
 Dr. Charles L. Proctor FS,SP,IN - 2,1
 Director
 (904) 392-7555

FORD MOTOR COMPANY
 Dearborn, MI 48121
 Dr. George A. Lavoie PP,PC,FS - 5,3,1
 Engineering & Research Staff
 (313) 323-1408

FOSTER WHEELER CORP.
 12 Peach Tree Hill Rd.
 Livingstn, NJ 07039
 Mr. Tom Taylor PP,IN,PC - 4,3,6
 (201) 533-3675

GAS RESEARCH INSTITUTE
 8600 West Bryn Mawr Ave.
 Chicago, Illinois 60631
 Dr. Jim Kezerle PP,PC - 4,2,3
 (312) 399-8331

GEORGE WASHINGTON UNIVERSITY
 Washington D.C. 20052
 Prof. Houston Miller FS,PC - 1,2
 Dept. of Chemistry

GENERAL ELECTRIC RESEARCH & DEVELOPMENT CENTER
 Schenectady, NY 12301
 Dr. Sanjay M. Correa PP,PC - 3,1

GENERAL MOTORS RESEARCH LABS
 Warren, Michigan 48090-9055
 Bruce Peters PP,PC - 5,1,3
 (313) 986-0032
 James C. Holzworth PP,PC
 Director of Interdepartment Programs

GEORGIA INSTITUTE OF TECHNOLOGY
 Atlanta, Georgia 30332
 Prof. Warren C. Strahle PP,PC - 1,3,5
 School of Aeronautical Engr.
 Prof. Ben T. Zinn PP - 3,5
 School of Aeronautical Engr.

B.F. GOODRICH TECHNICAL CENTER
 P.O. Box 122
 Avon Lake, OH 44102
 Dr. Marcela M. Hirschler FS - 1,3
 (216) 933-1780

GRINELL - PYROTECTOR INC.

333 Lincoln St.
Hingham, Mass.

John Jordan FS,SP - 1,3,6
Aerospace Marketing Mgr.
(617) 749-3466

GRINELL CORPORATION

Research & Development Ctr.
1467 Elmwood Ave.
Cranston, RI 02910

Jerome S. Pepi FS,SP,IN,PC - 1,3,4
Vice President
(401) 456-5770

GRUMMAN AEROSPACE CORP.

Research & Development Ctr.
Bethpage, NY 11714

Dr. Michael W. Slack SP,PP - 1,3,5
Head, Chemical Physics
(516) 575-2229
John W. Cox SP,PP - 1,5

FRANK B. HALL

89 Broad St.
Boston, Mass. 02110

John Ganger FS,SP
(617) 482-3100

HARVARD UNIVERSITY

Cambridge, Mass

Prof. Howard W. Emmons FS
(617) 495-2487

HONEYWELL

Physical Sc. Center
10701 Lyndale Ave., S.
Bloomington, MN 55420

Ulrich Bonne FS,SP - 1,3
(612) 887-4477

3660 Technology Dr.
Minneapolis, MN 55418

Jerry Wood SP,FS - 1,3
(612) 782-7063

Jim Wood PC
(612) 542-6773

I.C.I. AMERICAS INC.

Specialty Chem. Div.
Wilmington, Del. 19897

John Mossel FS,SP - 1,2
(302) 575-3535

UNIVERSITY OF ILLINOIS

144 MEB

1206 W. Green St.

Urbana, Illinois 61801

Prof. Roger A. Strehlow FS,SP,PP - 1,2,4

Dept. of Aeroengineering

(217) 333-3769

Prof. Herman Krier PP,PC - 1,3

Dept. of Mechanical Engr.

(217) 333-0529

Prof. Jim Peters PP,PC - 1

Dept. of Mechanical Engr.

(217) 333-3237

ILLINOIS INSTITUTE OF TECHNOLOGY

Chicago, Illinois 60616

Dr. Hal Wakely IN - 4

(312) 567-4705

INDUSTRIAL RISK INSURERS

85 Woodland St.

Hartford, CT 06102

Jim A. Lambert FS,SP

V.P., Loss Prevention

(203) 520-7300

INSTITUTE OF GAS TECHNOLOGY

3424 South State St.

Chicago, Illinois 60616

Robert Macriss IN,PC - 4,3,2

(312) 890-6444

RALPH JENSEN ASSOCIATES

104 Wilmot Rd.

Deerfield, IL 60015

Steve Moran FS,SP

(312) 948-0700

THE M.W. KELLOGG COMPANY

Three Greenway Plaza East

Houston, Texas 77046

Dr. R.E. Levy IN - 4,3

V.P., Technology Development

(713) 960-2601

UNIVERSITY OF KENTUCKY

Dept. of Mechanical Engr.

Lexington, KY 40506

Prof. Robert B. Altenkirch FS,SP,PC - 1,3,6

(606) 257-2663

ARTHUR D. LITTLE INC.

Acorn Park
Cambridge, Mass 02140
(617) 864-5770

Paul A. Croce FS,SP,PP,PC - 1,3,4,6
Edwin L. Field " " " "
Paul B. Monaghan " " " "
R.P. Wilson Jr " " " "

LOUISIANA STATE UNIVERISTY

Baton Rouge, LA 70803
Dept. of Mechanical Engineering
Ceba Bldg., Rm 2508

Prof. Thomas W. Lester FS,PC - 2,3
(504) 388-5792
Tina Cheng FS - 2
(504)388-5823

LUBRIZOL CORP.

29400 Lakeland Blvd.
Wickliffe, OH 44092

Dr. G.R. Hill IN - 3
V.P., Research & Development
(216) 943-4200

MASSACHUSETTS INSTITUTE OF TECHNOLOGY

Dept. of Chemical Engr.
Cambridge, MA 02139

Prof. J.M. Beer PP,PC,IN - 3,4,2,1
(617) 253-6661
Prof. Jack B. Howard PP,PC,IN - 1,2,3
(617) 253-4574
Prof. John B. Heywood PP,PC,FS - 5,1,3
(617) 253-2243
Prof. John P. Longwell FS,PC,PP - 1,3,4
(617) 253-4534
Prof. Adel F. Sarafim PC,FS,PP - 3,1,2
(617) 253-4587
Prof. Glen C. Williams PC,FS,PP - 2,4,1
(617) 253-4587

McDONNELL DOUGLAS RESEARCH LABS

P.O. Box 516
St. Louis, MO 63166

James M. Madcon PP,PC - 1,3

UNIVERSITY OF MICHIGAN

Aerospace Engr.
Ann Arbor, Michigan 48109
(313) 764-7200

Prof. Martin Sichel FS,PP,PC - 1,2,5
Prof. Gerald M. Faeth PP,PC - 1,3,5
Prof. William Kaufman FS,PC,PP - 1,2,5,3

MICHIGAN TECHNOLOGY UNIVERSITY

Dept. of Mechanical Engr.
Houghton, MI 49931

Prof. John H. Johnson PP,PC - 5,3
Chairman
(906) 487-2576

MOBILE RESEARCH & DEVELOPMENT CORP.

Central Research Div.
P.O. Box 1025
Princeton, NJ 08540

Dr. Ralph Powell IN
(609) 737-3000

MORGANTOWN ENERGY TECHNOLOGY CTR.

Morgantown, West Virginia

Dr. Paul Wieber PP,PC - 1,3,2,6
Office of Technical Management
Deputy Assoc. Dir.
(304) 291-4364

Dr. Daniel Maloney PP,PC - 1,3,6

NALCO CHEMICAL CO.

1 NALCO Center
Naperville, IL 60566

Paul Colombo IN
Technical Director, Research
(312) 961-9500, Ext. 2060

NATIONAL BUREAU OF STANDARDS

Bldg. 224
Center for Fire Research
Gaithersburg, MD 20899

Dr. Richard G. Gann FS,SP,PP,PC,IN - 3,6,1,4
Chief Fire Research Div.
(301) 976-6866

Takashi Kashiwagi " " " "
Rm B-258
(301) 975-6699

David Evans " " " "
Rm A-345
(301) 975-6897

George Mulholand " " " "
Rm B-258
(301) 975-6695

NAVAL RESEARCH LAB

Washington D.C. 20375

Homer Carhart FS,SP,PP - 1,3,6
(202) 767-2262

Fred Williams FS,SP,PP - 1,3,6
(202) 767-2476

Elaine Oran FS,SP - 1,3
(202) 767-2960

UNIVERSITY OF NEW MEXICO

New Mexico Engineering Research Inst.
Campus Box 25
Albuquerque, NM 87131

Dr. Robert E. Tapscott FS,SP - 4,3,6
Acting Manager, APT Div.
(505) 844-4644

UNIVERSITY OF NORTH DAKOTA

Energy Research Center
P.O. Box 8213
Grand Forks, ND 58201

Dr. H. Peter Hombach PP,PC - 3,1
(701) 777-5147

OAK RIDGE NATIONAL LAB

Post Office Box Y
Oak Ridge, TN 37381

C. Stewart Daw FS,PP,PC - 2,1
Bldg. 9108
(615) 574-0373

OHIO STATE UNIVERSITY

Columbus, OH 43210

Prof. Robert H. Essenhigh PP,PC - 3,1
206 West 18th Ave.
Director, Fuels & Combustion Lab.
(614) 292-0403

Prof. Lawrence R. Kennedy FS,PP,PC - 2,4
Dept. of Mechanical Engineering

OREGON STATE UNIVERISTY

Mechanical Engineering Dept.
Corvallis, OR 97331

Dr. A.M. Kanury PC,PP - 1,2
(503) 754-4902

UNIVERSITY OF OKLAHOMA

Norman, Oklahoma 73069

Prof. S.R. Gollahalli PP,IN - 3,1
Aerospace & Nuclear Engineering
(405) 325-7241

Dr. Sleipcevich IN,FS - 1,3
Flame Dynamics Lab
1215 Westheim
(405) 325-7263

PENN STATE UNIVERSITY

Dept. of Mechanical Engr.
University Park, PA 16802

Prof. Anil K. Kulkarni FS,PC - 1,3
(814) 865-4542

Prof. Kenneth K. Kuo FS,PP,PC - 3,1

Prof. Howard Palmer FS,SP,PC - 3,1,6
(814) 865-2516

PHYSICAL SCIENCES INC.

Research Park
Andover, MA 01810

(617) 475-9030

Dr. Arthur A. Boni FS - 1,3

Terry Parker FS - 3,1

PITTSBURGH ENERGY TECHNOLOGY CENTER

D.O.E.

P.O. Box 10940

Pittsburgh, PA 15236

Jim Hickerson FS,PP,PC - 1,2

MS 922

(412) 675-5721

Phil Goldberg FS,PC

(412) 675-5882

P.P.G. INDUSTRIES

Director, Research & Development, Glass

P.O. Box 11472

Pittsburgh, PA 15238

Mr. D. Emhizer IN

(412) 665-8515

Fiberglass Research Center

Manager of Engineering & Processes, Fiberglass

P.O. Box 28444

Pittsburgh, PA 15230

Mr. Vincent Gullotta IN

(412) 782-5130

PURDUE UNIVERSITY

West Lafayette, IN 47907

Prof. Winfred Phillips PP,PC

Head, Mechanical Engineering

(317) 494-5688

Prof. Arthur H. Lefebvre PP,IN,PC - 3,1

Mechanical Engineering

(317) 494-1516

Prof. Norman Laurendeaur PP,PC

(317) 494-2713

RESEARCH INDUSTRIES INC.

123 North Pitt St.

Alexandria, VA 22300

John Grove IN

Vice President

(703) 548-3667

R.J. REYNOLDS TOBACCO CO.

Bowman Gray Tech. Ctr.

Winston Salem, NC 27102

David E. Townsend PC - 1,3

(919) 773-4965

ROCKETDYNE

6633 Canoga Ave.
Canoga Park, CA 91304
Dr. Allen Ferrenberg PP - 5,3
FB 47
(818) 700-4300

SANDIA NATIONAL LABORATORIES

Livermore, CA 94550
Dr. William J. McLean PC,PP,FS,IN - 3,4,1,2
(415) 422-2687

SCIENCE APPLICATIONS INTERNATIONAL CORP.

Chatsworth, California
Ray Edelman PC,PP,IN - 4,2,3
(818) 709-5222

SOUTHERN CALIFORNIA GAS CO.

810 South Flower St.
Los Angeles, CA 90017
Mr. Watkins IN,PC - 4
Manager of Research M.L. 731D
(215) 689-2955

SOUTHERN CALIFORNIA UNIVERSITY

Dept. of Mechanical Engineering
Los Angeles, CA 90089-1453
Prof. P.R. Choudhury PP,PC - 4,1
(213) 743-6088
Prof. Melvin Gerstein PC,PP - 4,2
(213) 743-8914

SOUTHWEST RESEARCH INSTITUTE

Post Office Drawer 28510
San Antonio, TX 78284
Dr. Cliff Moses PC,IN
(512) 522-2370
Tom Ryan IN
(512) 522-2370

SRI INTERNATIONAL

Menlo Park, CA 94025
Dr. David R. Crosley IN
Molecular Physics Dept.
(415) 859-2395
John McCarty IN - 3
AG 218
(415) 859-2332

STANFORD UNIVERSITY

Dept. of Mechanical Engineering
Stanford, CA 94305

Prof. Craig T. Bowman PC,PP - 3,4
(415) 723-1745

Prof. Charles H. Kruger PC
(415) 723-4023

STEVENS INSTITUTE OF TECHNOLOGY

Dept. of Mechanical Engineering
Castle Point Station
Hoboken, NJ 07030

Dr. Richard S. Magee IN
(201) 420-5560

UNIVERSITY OF TEXAS ARLINGTON

Arlington, Texas 76019

Prof. Albert Y. Tong FS - 1,3

TRW

1 Space Park
Redondo Beach, CA 90278

Jack Kroppe PP
R1-2154
(213) 535-3451

Nahum Gat PP - 3
R1-1028
(213) 536-1694

UNDERWRITERS LAB, INC.

333 Pfingsten Rd.
Northbrook, IL 60062

Robert F. Skala FS,SP
(312) 272-2800

UNITED TECHNOLOGIES RESEARCH CTR.

Silver Lane

E. Hartford, CT 06108

(203) 727-7000

Dan Seery PP,PC,FS - 3,4,1

Manager, Combustion Sciences

(203) 727-7150

Joseph J. Santgiovanni PP,PC,FS - 4,3,1

(203) 727-7328

Paul Bopnczyk PP,PC - 4,3

(203) 727-7162

Med Colket PC,PP - 3,4

(203) 727-7481

Bob Hall PP,PC - 4,3

(203) 727-7348

Jan Kennedy PP,PC - 3,4

(203) 727-7582

Brian Knight PP,PC - 3,4

(203) 727-7293

Dave Liscinsky PP,PC - 3,4

(203) 727-7293

Bill Proscia PC,PP - 4,3

(203) 727-7679

UNIVERSITY OF UTAH

310 Park

Salt Lake City, Utah 84112

Prof. David W. Pershing PP,PC - 3,1

(801) 581-6925

UNIVERSITY OF VERMONT

C.E.M.E. Dept.

Burlington, VT 05405

Prof. Clark E. Hermance PP,PC - 3,1

UNIVERSITY OF WISCONSIN

Madison, WI 53706

Prof. Gary L. Borman PP,PC - 5,1,3

1500 Johnson St.

Director of Internal Combustion Lab

(608) 263-1616

Prof. Ken Ragland PP,IN,PC - 3,1

Dept. of Mechanical Engr.

(608) 263-5963

Prof. P.S. Myers PP,PC - 3,1,5

Dept. of Mechanical Engr.

WORCESTER POLYTECHNIC INST.
Center for Fire Safety Studies
100 Institute Road
Worcester, Mass. 01609

Prof. Richard Custer FS,SP - 1,2,3,4
Director
(617) 793-5562
Prof. Craig L. Beyler FS,SP - 1,3
(617) 793-5124
Prof. William Dorgin SP - 1
Head, Aeronautics & Space Dept.

YALE UNIVERSITY
Yale Station
P.O. Box 2159
New Haven, Connecticut 06511

Prof. John B. Fenn PC

REFERENCES

1. "Accommodation Requirements for Microgravity Science and Applications Research on Space Station." NASA CR-175038. Wyle Laboratories Interim Report for NASA Contract NAS3-24654, December 1985.

TABLE I. - INTEREST IN EXPERIMENTS

Experiment category	Interest group				
	Fire safety terrestrial	Fire safety space	Propulsion and power	Industrial burners	Pollution control
No flow liquid solid	High	Medium	High	Low	High
Homogeneous mix. fuel-air	High	Low	Medium	Low	Low
Low flow solid and liquid	High	High	Low	Medium	High
Low flow gaseous fuel	Low	Low	Low	High	Medium
High pressure combustion	None	None	High	None	Medium
Special burners	Low	Medium	Low	None	None

Definition of interests:

High Very involved and with a definite need for technology.
 Medium Interested in experiments and derived technology.
 Low Minor interest in experiments and general technology.
 None No specific needs but may have interest in technology.

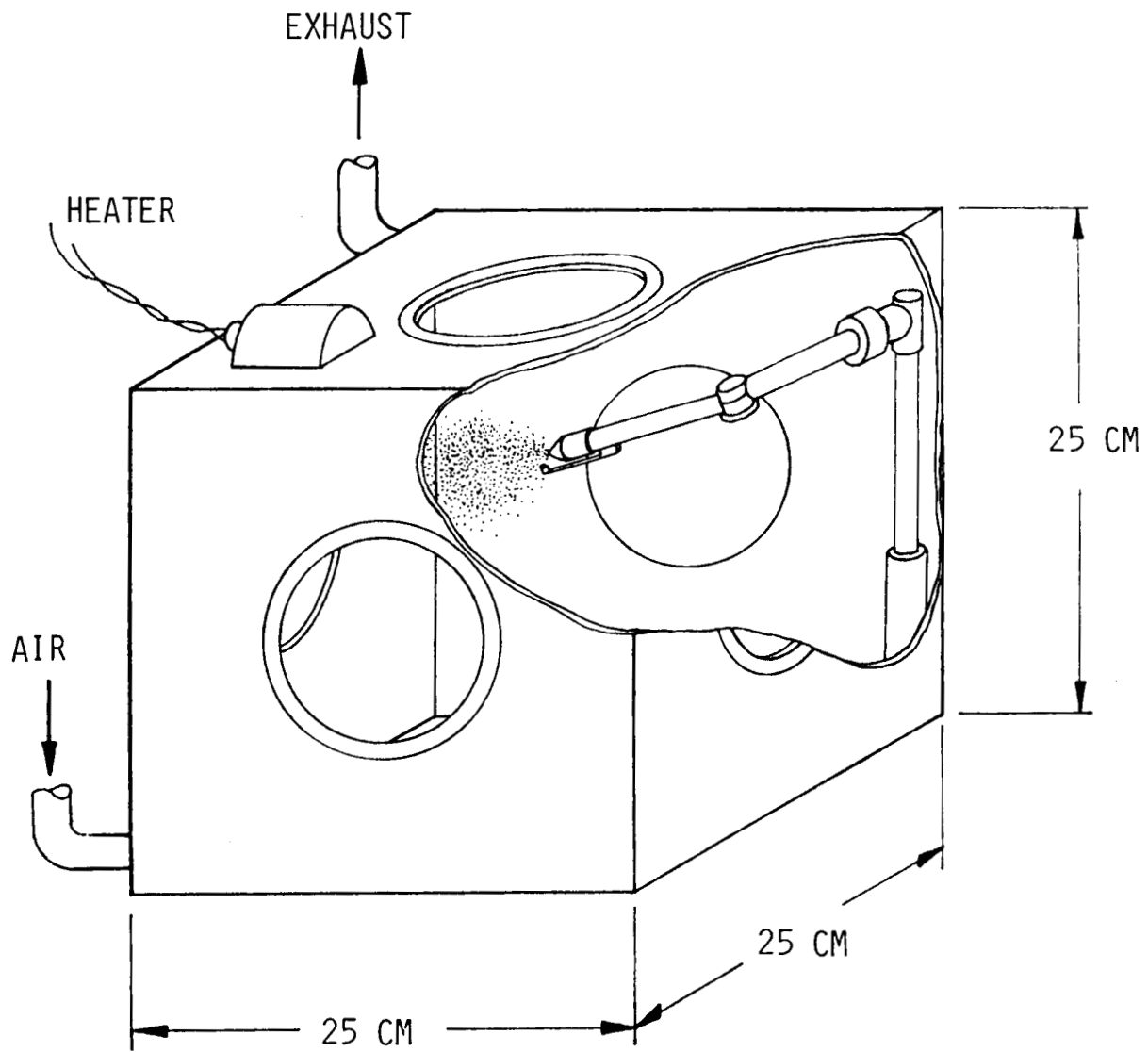

FIGURE 1a
EXPERIMENTAL APPARATUS FOR TESTING
SPHERICAL FUEL PARTICLES WITH NO FLOW

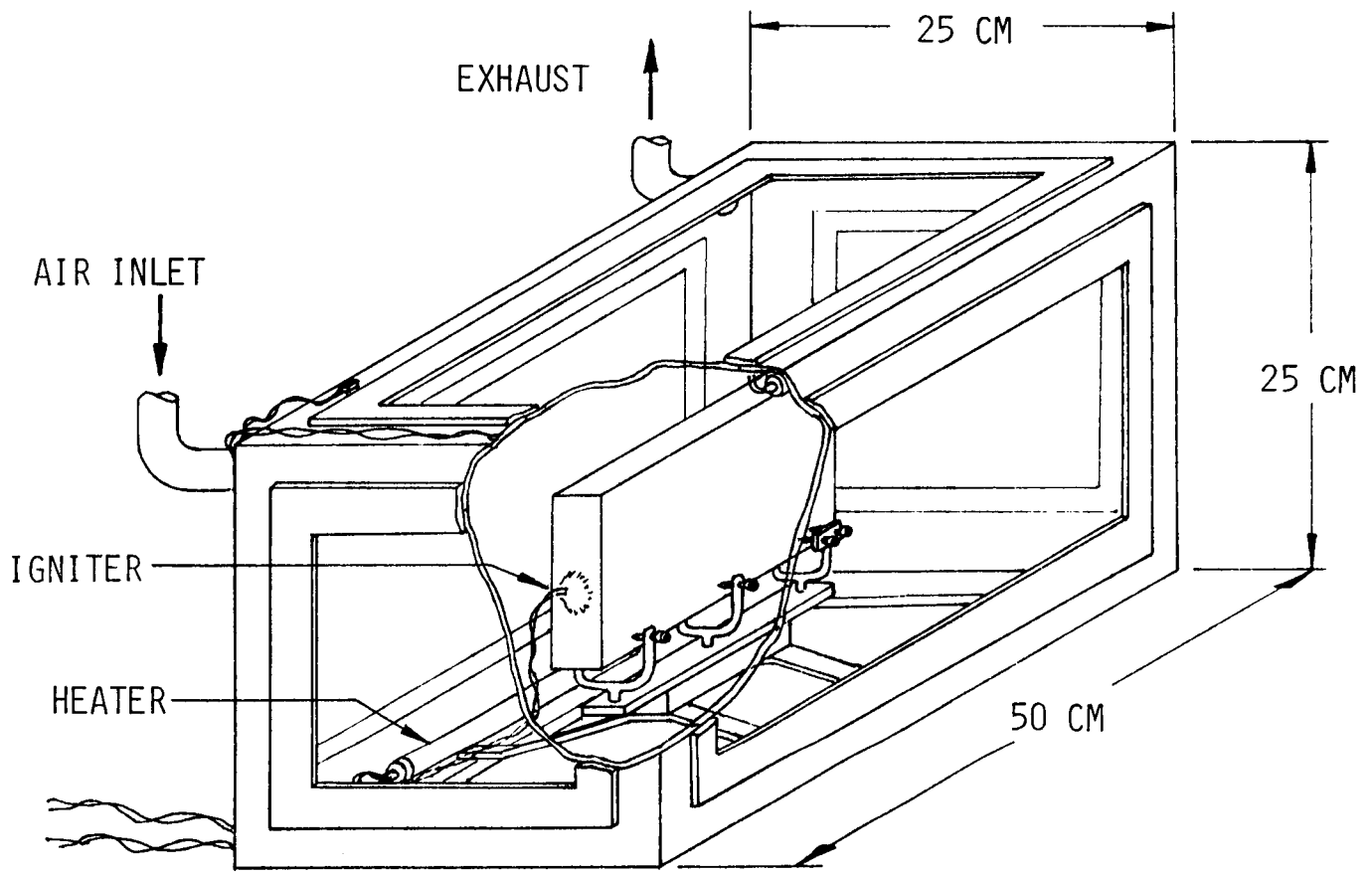

FIGURE 1b
EXPERIMENTAL APPARATUS FOR TESTING
CYLINDRICAL OR FLAT FUEL SAMPLES WITH NO FLOW

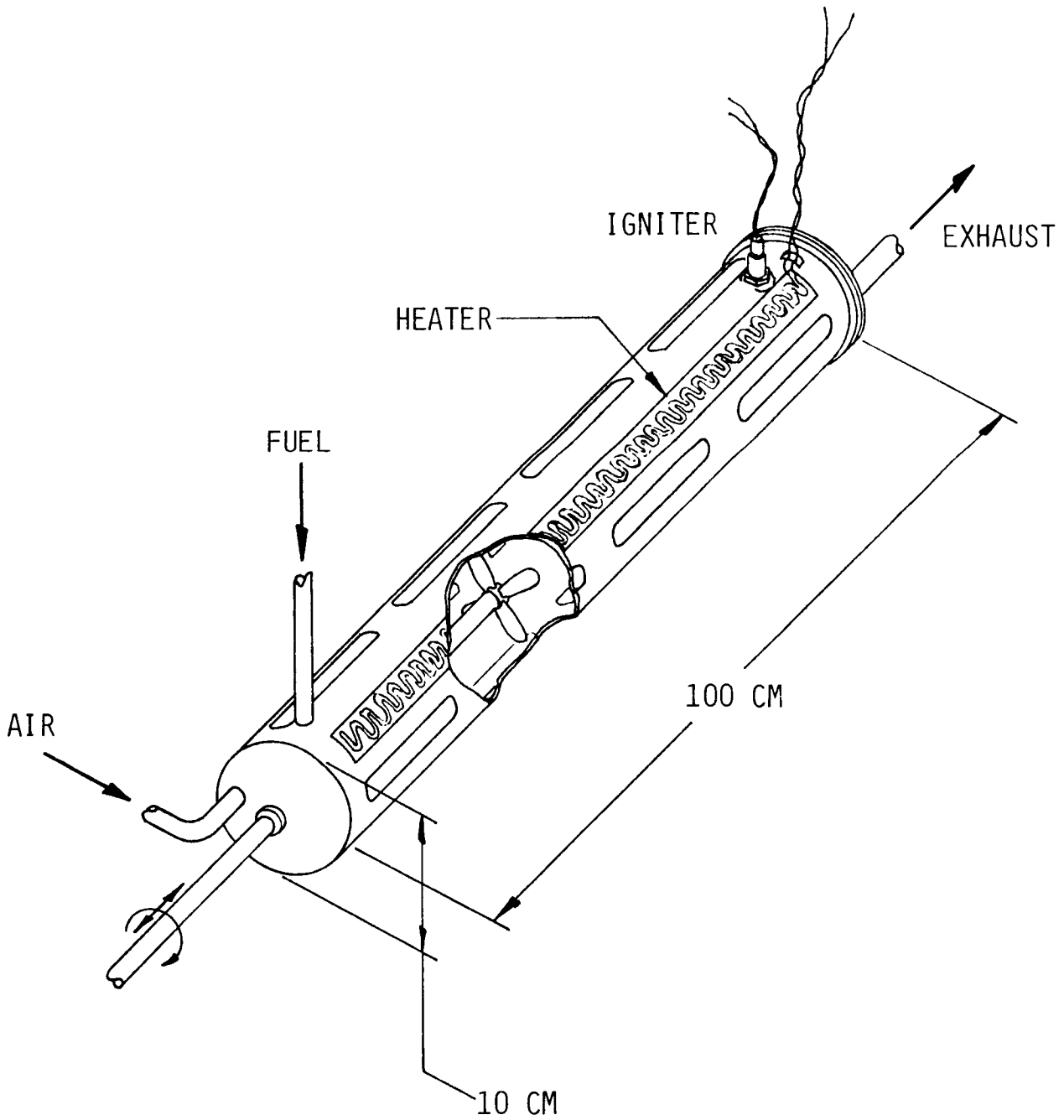

FIGURE 2
APPARATUS FOR HOMOGENEOUS FUEL-AIR MIXTURE EXPERIMENTS

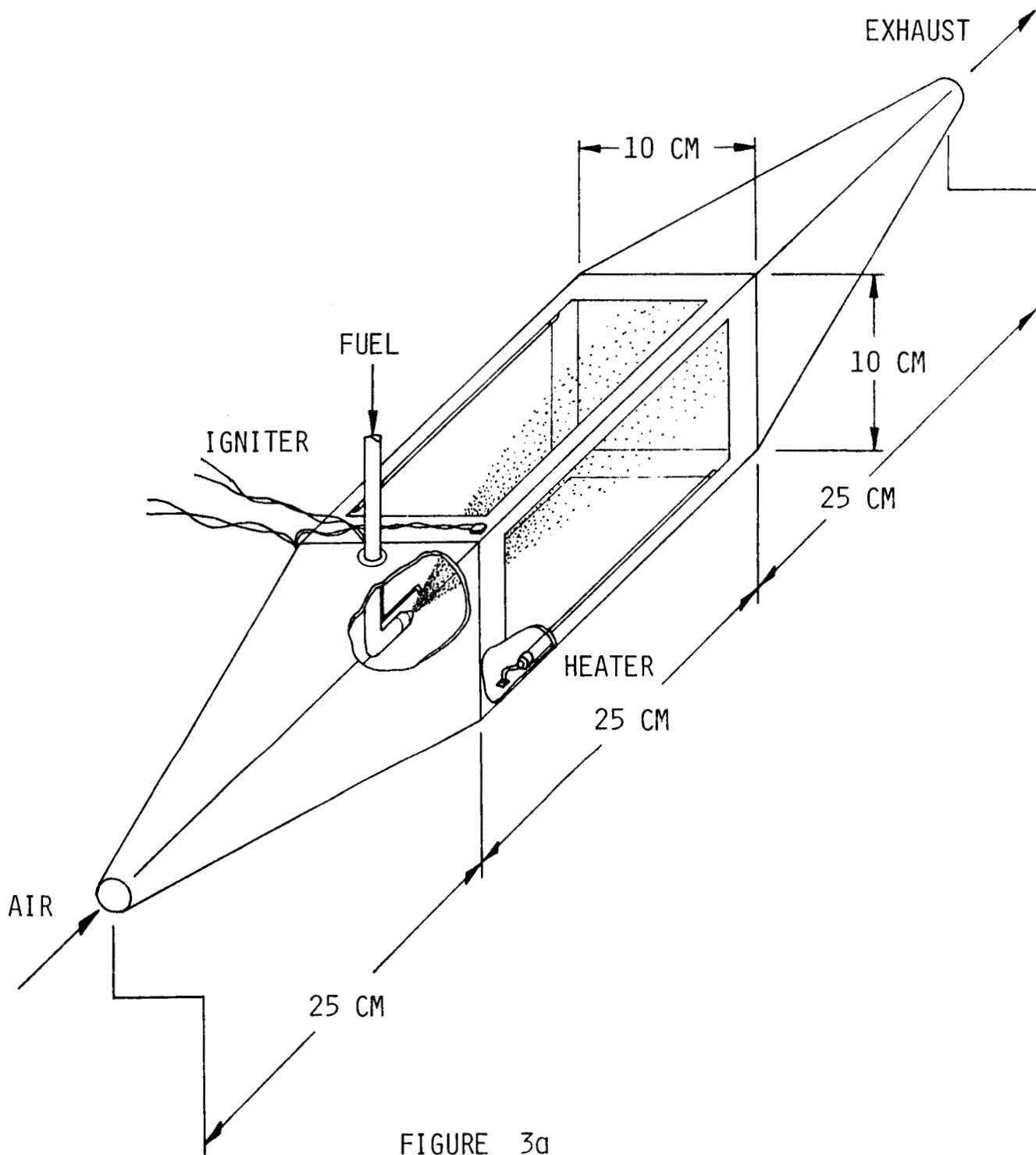

FIGURE 3a
 EXPERIMENTAL APPARATUS USING
 LOW FLOW WITH DROPS OR PARTICLES

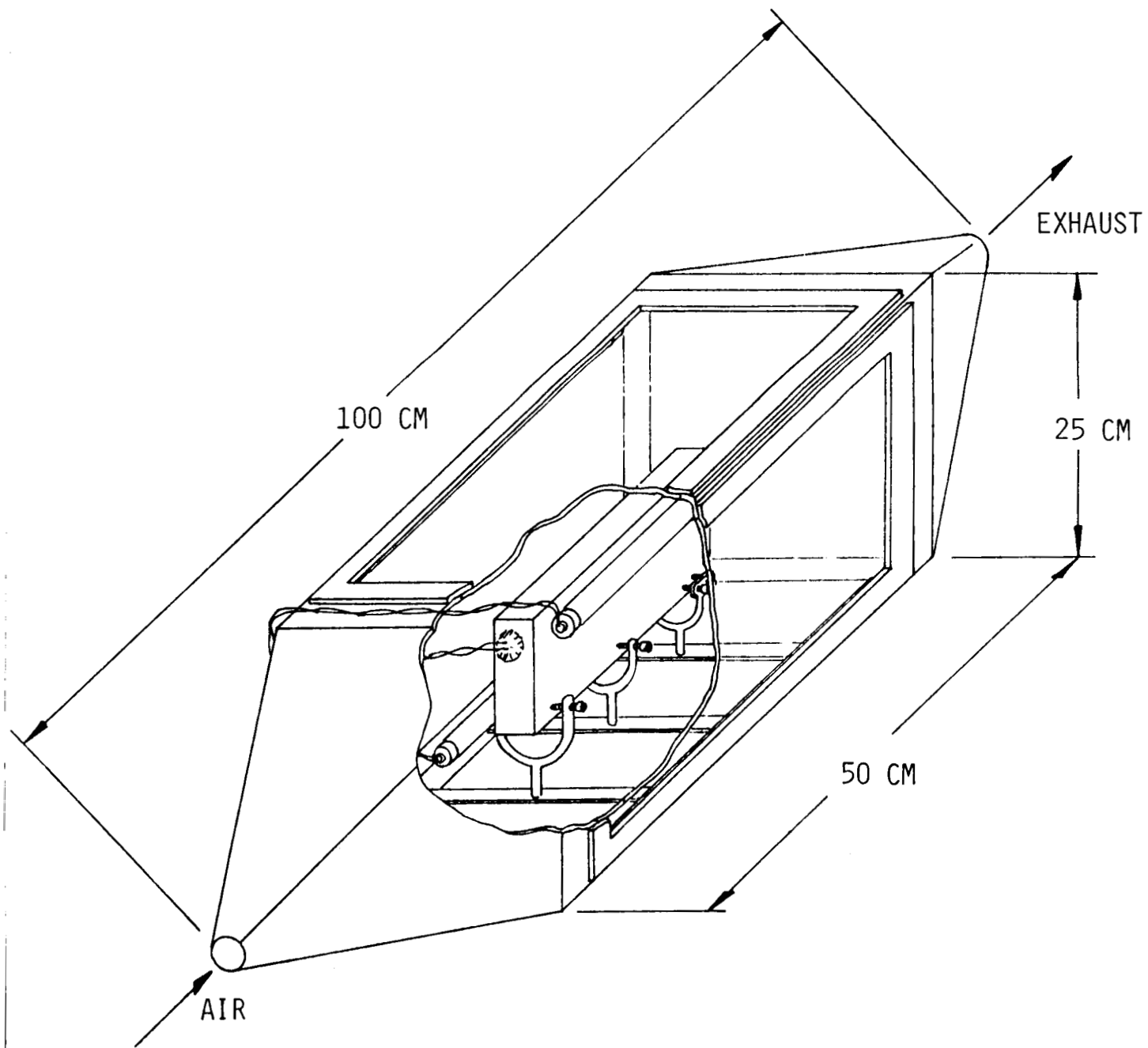

FIGURE 3b
EXPERIMENTAL APPARATUS USING
LOW FLOW WITH TWO DIMENSION FUEL SAMPLES

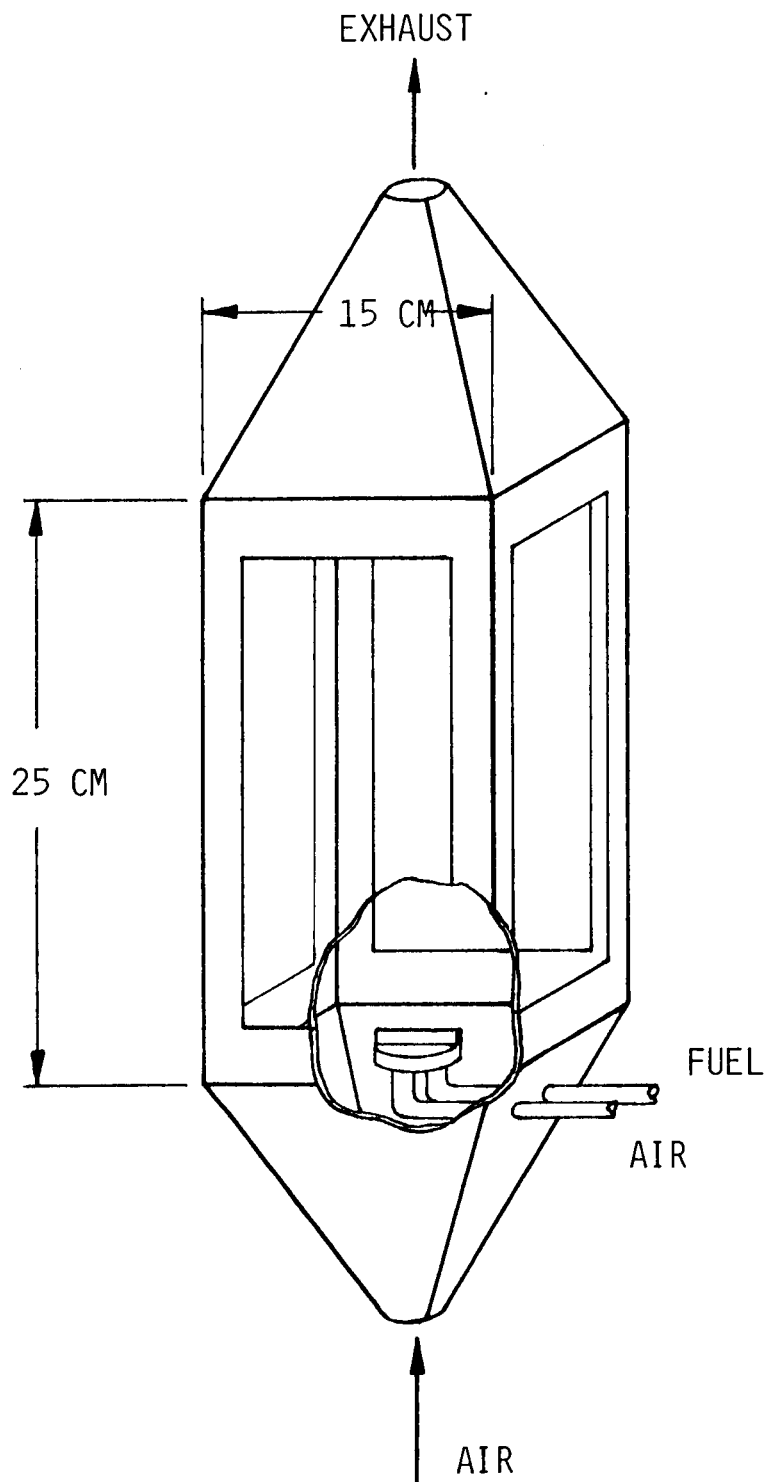

FIGURE 4a
SCHEMATIC OF APPARATUS USED
WITH GASEOUS FUEL-AIR BURNERS

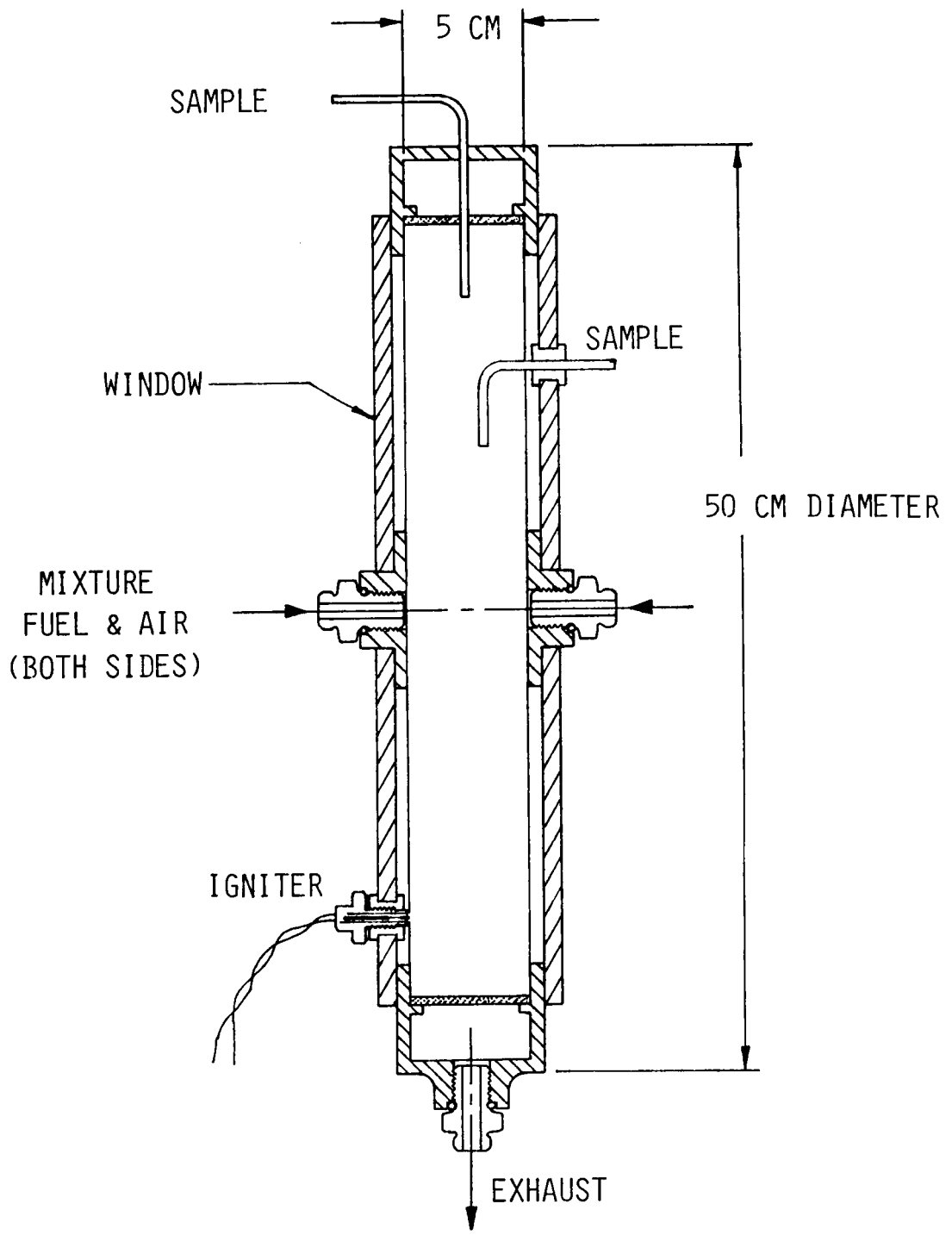

FIGURE 4b
 SCHEMATIC OF OPPOSED JET FUEL BURNER

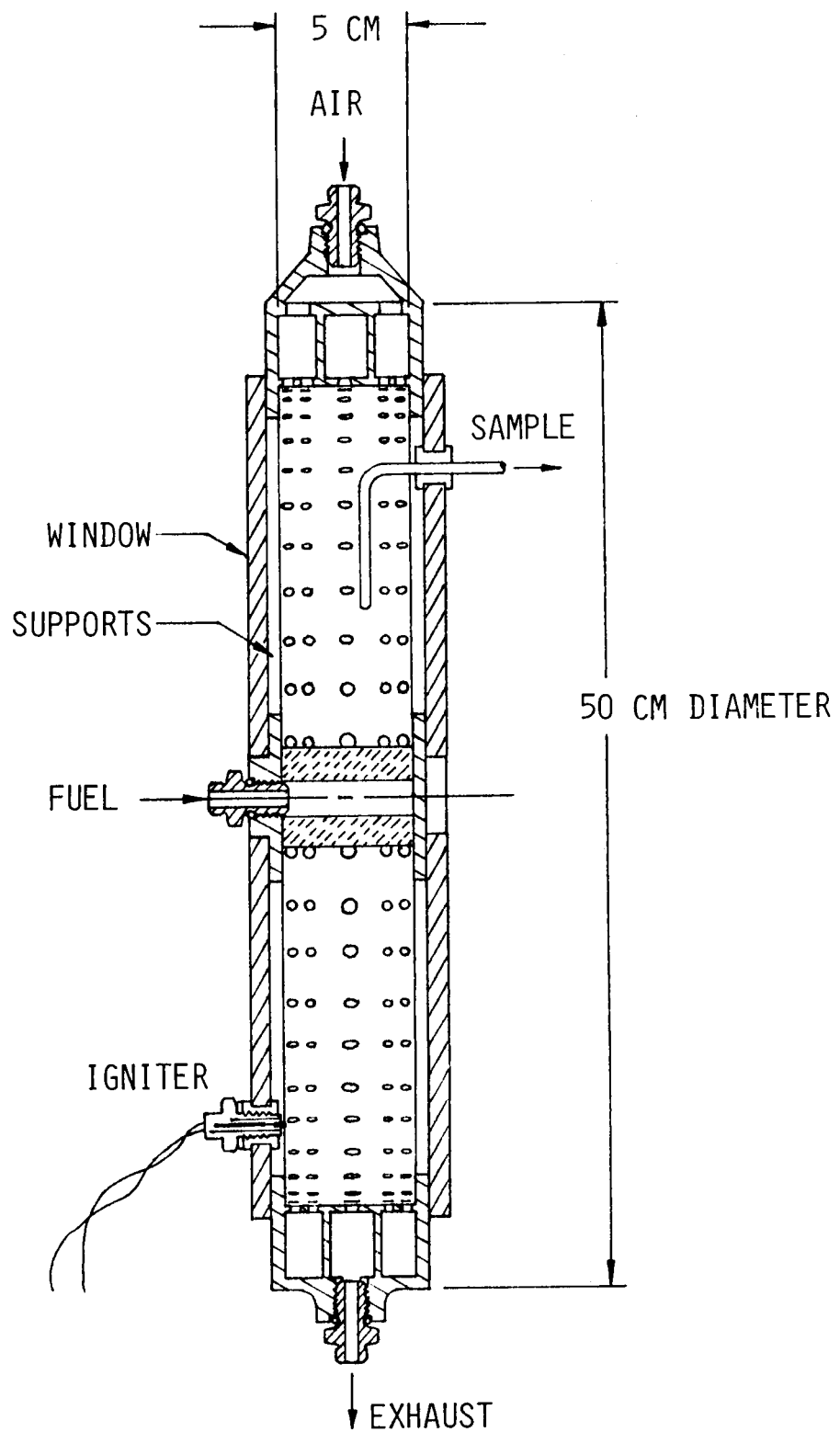

FIGURE 4c
 SCHEMATIC OF CYLINDRICAL GASEOUS FUEL
 DIFFUSION FLAME BURNER

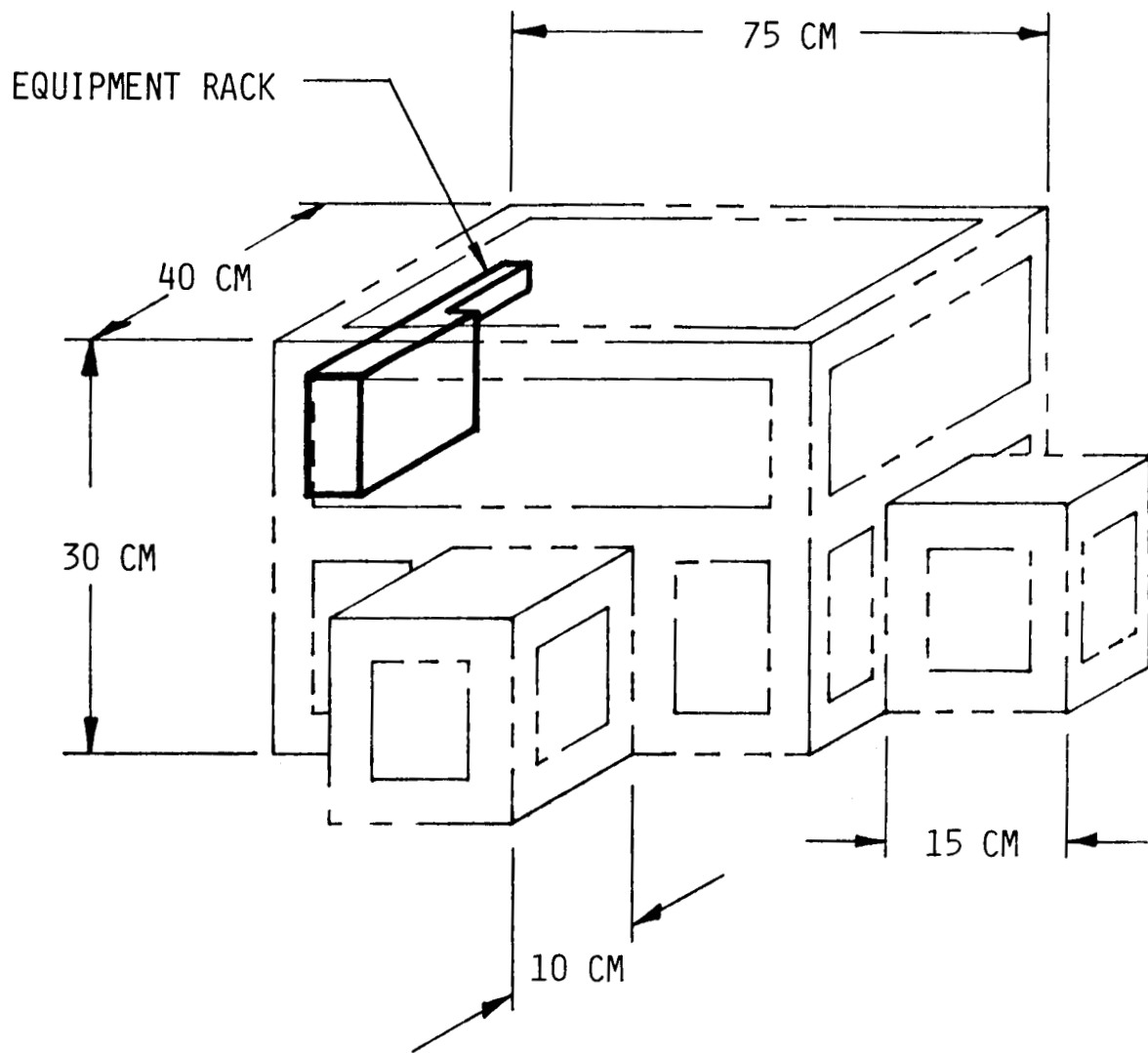

FIGURE 5
SCHEMATIC OF APPARATUS FOR
FIRE SAFETY MODELING OF SPACE STATION

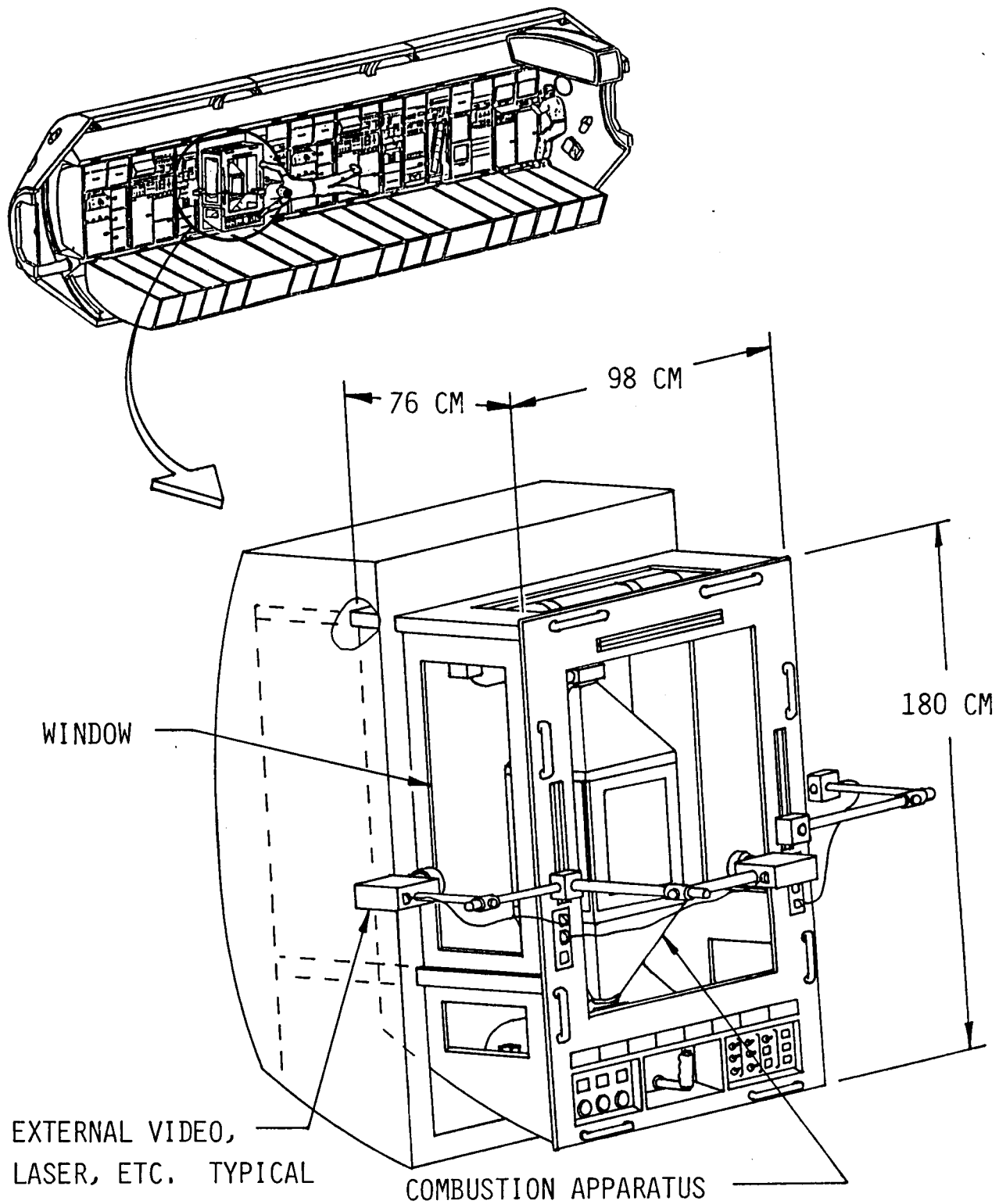

FIGURE 6
SCHEMATIC OF MICROGRAVITY COMBUSTION FACILITY

1. Report No. NASA CR-180854		2. Government Accession No.		3. Recipient's Catalog No.	
4. Title and Subtitle Study of Industry Requirements That Can Be Fulfilled by Combustion Experimentation Aboard Space Station				5. Report Date March 1988	
				6. Performing Organization Code	
7. Author(s) Richard J. Priem				8. Performing Organization Report No. None (E-3901)	
				10. Work Unit No. 480-21-02	
9. Performing Organization Name and Address Sverdrup Technology, Inc. Lewis Research Center Cleveland, Ohio 44135-3191				11. Contract or Grant No. NAS3-24105	
				13. Type of Report and Period Covered Contractor Report Final	
12. Sponsoring Agency Name and Address National Aeronautics and Space Administration Washington, D.C. 20546-0001				14. Sponsoring Agency Code	
15. Supplementary Notes Project Manager, Gilbert J. Santoro, Space Experiments Division, NASA Lewis Research Center. Richard J. Priem, Priem Consultants Inc., subcontractor to Sverdrup Technology, Inc. (Subcontract No. 5509-80, Jack Grobman, Monitor.)					
16. Abstract <p>The purpose of this study is to define the requirements of commercially motivated microgravity combustion experiments and the optimal way for Space Station to accommodate these requirements. This was accomplished by contacting 181 individuals representing 113 commercial organizations, universities, or government agencies. Interests in and needs for microgravity combustion studies are identified for commercial/industrial groups involved in fire safety with terrestrial applications, fire safety with space applications, propulsion and power, industrial burners, or pollution control. From these interests and needs experiments involving (1) no flow with solid or liquid fuels, (2) homogeneous mixtures of fuel and air, (3) low flow with solid or liquid fuels, (4) low flow with gaseous fuel, (5) high pressure combustion, and (6) special burner systems are described and Space Station resource requirements for each type of experiment are provided. Critical technologies involving creating a laboratory environment and methods for combining experimental needs into one experiment in order to obtain effective use of Space Station are discussed. Diagnostic techniques for monitoring and recording combustion process parameters that need development for efficient use of Space Station are identified.</p>					
17. Key Words (Suggested by Author(s)) Combustion; Space Station; Microgravity combustion; Spacecraft fire safety			18. Distribution Statement Unclassified - Unlimited Subject Category 85		
19. Security Classif. (of this report) Unclassified		20. Security Classif. (of this page) Unclassified		21. No of pages 60	22. Price * A04