

NGT-80001  
IN-07-CR  
128711  
66

**ADVANCED PROPFAN ANALYSIS  
FOR THE FAMILY OF COMMUTER AIRPLANES**

NGT-21-020-080

**PREPARED FOR:** NASA GRANT NGT-~~0001~~ NGT 80001

**PREPARED BY:** GERALD A. SWIFT  
  
UNIVERSITY OF KANSAS  
AE 790 DESIGN TEAM  
MAY 1987

**TEAM LEADER:** TOM CREIGHTON

**TEAM MEMBERS:** RAPHAEL HADDAD  
LOUIS HENDRICH  
DOUG HENSLEY  
LOUISE MORGAN  
MARK RUSSELL  
GERALD SWIFT

**FACULTY ADVISOR:** DR. JAN ROSKAM

(NASA-CR-182566) ADVANCED PROPFAN ANALYSIS  
FOR THE FAMILY OF COMMUTER AIRPLANES  
{Kansas Univ.} 66 p CSCL 21E

N88-19468

Unclas  
G3/07 0128711

ADVANCED PROPFAN ANALYSIS  
FOR THE FAMILY OF COMMUTER AIRPLANES

PREPARED FOR: NASA GRANT NGT-8001

PREPARED BY: GERALD A. SWIFT

UNIVERSITY OF KANSAS  
AE 790 DESIGN TEAM  
MAY 1987

TEAM LEADER: TOM CREIGHTON

TEAM MEMBERS: RAPHAEL HADDAD  
LOUIS HENDRICH  
DOUG HENSLEY  
LOUISE MORGAN  
MARK RUSSELL  
GERALD SWIFT

FACULTY ADVISOR: DR. JAN ROSKAM

## Table of Contents

	<u>Page</u>
Table of Symbols	iv
1. Introduction	1
2. Propulsion System Selection	2
2.1. V2500 High Bypass Ratio SuperFan	2
2.2. General Electric Unducted Fan (UDF)	3
2.3. Contra-Rotating Integrated Shrouded Propfan (CRISP)	4
2.4. Pratt/Whitney-Allison 578-DX Demonstrator Propfan	4
2.5. Propulsion System Selected	5
3. Propeller Design and Performance	6
4. Engine Design and Performance	9
4.1. Design Specifications	9
4.2. Engine Component Description	10
4.2.1. Inlet	10
4.2.2. Compressors	11
4.2.3. Axial Combustor	12
4.2.4. Turbines	13
4.2.5. Nozzle	13
4.3. Engine Accessories	15
4.4. Engine Outline Drawing	15
4.5. Gearbox Design	15
4.6. Installed Performance	19
4.7. Weight	19
4.8. Costs	19
5. Integration and Commonality	42

<b>6. Noise</b>	<b>48</b>
6.1. Sources	48
6.2. Noise Characteristics	48
6.3. Cabin Noise Reduction	51
<b>7. Conclusions and Recommendations</b>	<b>60</b>
7.1. Conclusions	60
7.2. Recommendations	60
<b>8. References</b>	<b>61</b>

### Table of Symbols

<u>Symbol</u>	<u>Definition</u>	<u>Dimension</u>
A	Aspect ratio	-----
BPR	Bypass ratio	-----
C/D	Clearance between fuselage and propeller	ft.
C <sub>Do</sub>	Zero-lift drag coefficient	-----
db	Decibels	db
D <sub>prop</sub>	Propeller diameter	ft.
e	Oswald's efficiency factor	-----
GR	Gearing ratio	-----
K <sub>fsp</sub>	Specific fuel weight	lbs/gal
K <sub>osc</sub>	Oil system constant	-----
L <sub>nac</sub>	Nacelle length	ft.
M	Mach number	-----
N <sub>e</sub>	Number of engines	-----
N <sub>t</sub>	Number of fuel tanks	-----
P <sub>avl</sub>	Power available	hp
P <sub>req</sub>	Power required	hp
ROC	Rate of climb	fpm
RPM	Rotational speed	rpm
s <sub>fc</sub>	Specific fuel consumption	lb/hp/hr
shp	Shaft horsepower	hp
TSFC	Thrust specific fuel consumption	lb/hp/hr
W <sub>e</sub>	Engine weight	lbs
W <sub>F</sub>	Fuel weight	lbs
W <sub>fs</sub>	Fuel system weight	lbs
W <sub>gb</sub>	Gearbox weight	lbs
W <sub>n</sub>	Nacelle weight	lbs
W <sub>osc</sub>	Oil system weight	lbs
W <sub>prop</sub>	Propeller weight	lbs

#### Greek

$\alpha$	Angle of attack	degrees
$\eta_{NET}$	Net efficiency	-----
$\eta_p$	Propeller efficiency	-----
$\theta$	Sideline angle	degrees
$\Lambda$	Sweep angle	degrees
$\pi$	Pi	3.1416

#### Acronyms

AMADS	Aircraft mounted accessories drive system
AWST	<u>Aviation Week and Space Technology</u>
CR	Counter-rotation
HP	High pressure
LP	Low pressure

## 1. Introduction

This report is the fifth in a series of seven dealing with the design of a family of commuter airplanes for NASA Grant NGT-8001. The main emphasis behind the family of commuters is to achieve high commonality over a broad spectrum of passenger ranges (25 to 100 passengers). This could allow for a cooperation between an airline and airframe manufacturer that could revolutionize the commuter market. This report focuses on the propulsion system incorporated throughout the proposed family.

Advanced propfans have been selected to be used throughout the family of commuters. These propulsion systems offer a 25-28% fuel savings over comparably sized turbofans operating in the 1990's. The engines used in this study are derivatives of the,

PD436-11  
Turboprop Engines

NASA CR-168115  
Allison Gas Turbine Division

The engines will be mounted in aft pylons extending from the tailcone sections. The family of commuters concept requires two versions of this engine be used:

- (1) 5,500 shp engine
- (2) 11,000 shp engine

The technology included in these propulsion systems is verifiable in the late 1980's and is appropriate for production in the mid-1990's.

Chapter 2 provides a brief study of the propulsion systems available for the family of commuters and justifies the selection of the advanced turboprops.

Chapters 3 and 4 deal with propeller and engine designs and performance. In Chapter 5, these designs are integrated and examined.

Chapter 6 addresses noise considerations and constraints due to propfan installation.

## 2. Propulsion System Selection

The family of commuters will incorporate a propulsion system appropriate for production by the mid-1990's. Currently, several engine concepts are being proposed by leading propulsion manufacturers which also meet this timeframe. The following is a brief summary of some of the recent designs which are applicable to the family of commuters.

### 2.1. V2500 High Bypass Ratio SuperFan

This concept, shown in Figure 1, has been proposed by International Aero Engines. The following are some of the engine characteristics:

Diameter: 108 - 118 inches (9 - 10 feet)  
Bypass Ratio: 18-20:1  
Thrust: 25,000 - 30,000 pounds

Although engine testing began in 1985, a number of test failures and incidents have occurred. The engine's specific fuel consumption is predicted to be comparable to unducted propfans; however, the program is experiencing difficulty. According to Aviation Week and Space Technology (April 13, 1987), Airbus has decided to cancel its proposal for incorporating the SuperFan on the new A340's.

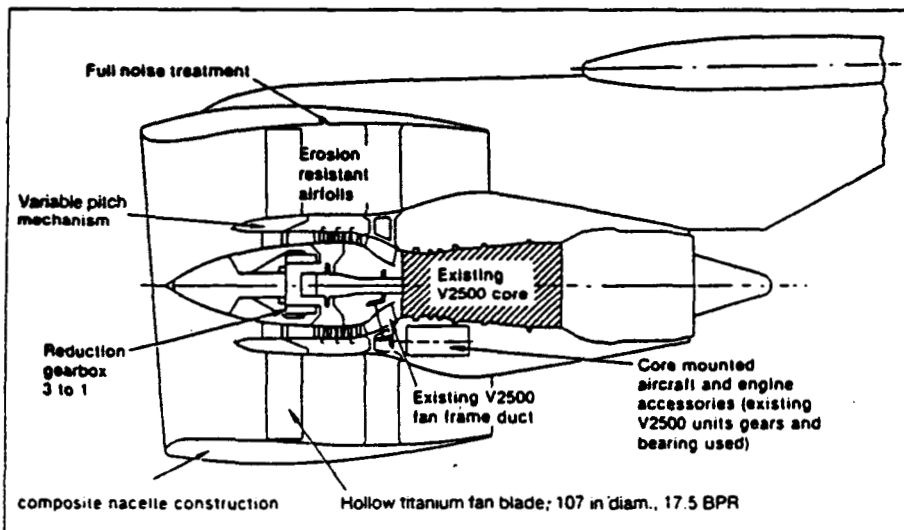

International Aero Engines' V2500 SuperFan ultrahigh bypass ratio engine rated at 30,000 lb. thrust has been selected to power the A340. Cutaway drawing shows the engine's latest configuration. CFM International also is considering offering a 30,000-lb.-thrust version of its CFM56 engine for the A340. Range of the A340-300 with V2500 SuperFans is estimated at 7,000 naut. mi. with a payload of 295 passengers and luggage (AW&ST July 7, 1986, p. 26).

Figure 1. International Aero Engines' V2500 SuperFan.

## 2.2. General Electric Unducted Fan (UDF)

This concept is shown in Figure 2. As of April 1987, the UDF had undergone 42 hours of flight tests and 58 hours of ground tests. The following is a brief summary of the UDF:

- \* 25% decrease in fuel consumption over the best turbofans of the 1990's
- \* 21,000 - 25,000 lb. thrust powerplant
- \* Designed to cruise at Mach 0.72, 35,000 feet
- \* Scheduled to be used on the Boeing 7J7 and MD-80
- \* Expecting initial deliveries by 1992
- \* Predicting a 6,000 engine market
- \* Carbon fiber composite blades with nickel alloy leading edges
- \* Counterweight-base blade overspeed protection system which automatically increases blade pitch to prevent overspeeds if control actuation is lost.

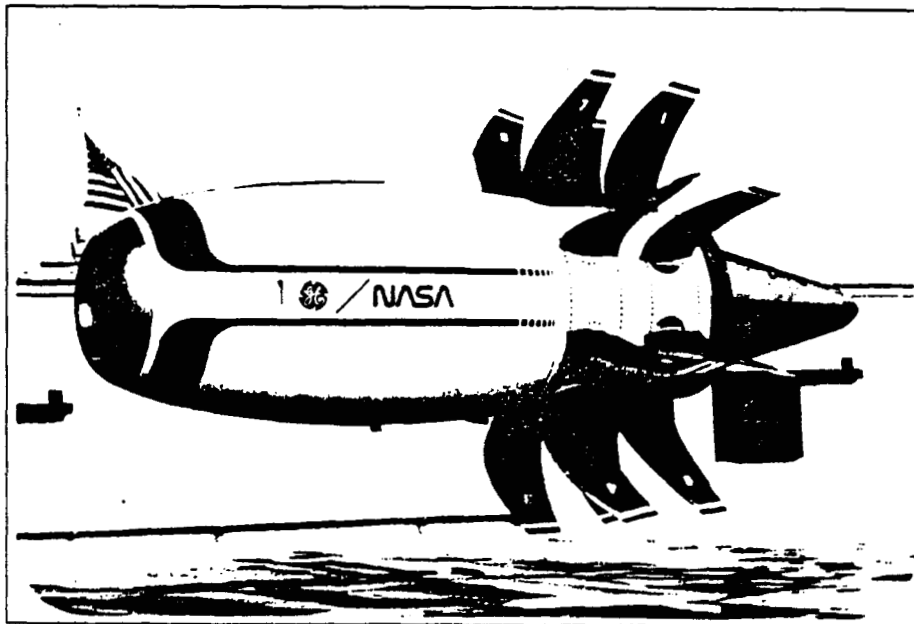

GENERAL ELECTRIC  
U.S.A.

Unducted Fan Engine (UDF™)

Figure 2. General Electric Unducted Fan Engine.



ORIGINAL PAGE IS  
OF POOR QUALITY

### 2.3. Contra-Rotating Integrated Shrouded Propfan (CRISP)

This concept, shown in Figure 3, is currently being studied by Motoren- und Turbinen-Union (MTU) of West Germany. Some of its characteristics are as follows:

- \* Bypass ratio of 20-30:1
- \* Shroud can be used for noise damping and blade containment
- \* Cannot obtain specific fuel consumption of an unducted propfan
- \* Shroud drag needs to be worked out.

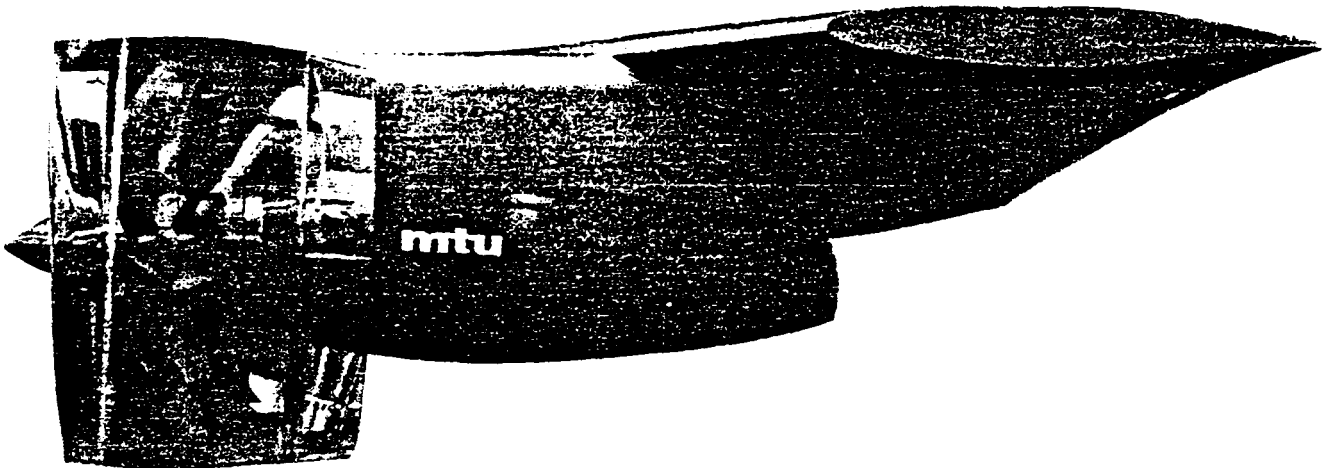

Figure 3. MTU Contra-Rotating Integrated Shrouded Propfan.

### 2.4. Pratt/Whitney-Allison 578-DX Demonstrator Propfan

This design will be tested on a demonstrator MD-80 this year. This engine is basically the proof-of-concept version of the engines incorporated in the K.U. Family of Commuters. The following are some of the design's characteristics:

- \* 10,400 shp demonstrator engine
- \* Two 11.6 ft. diameter, 6-blade propfans designed by Hamilton Standard
- \* Bypass ratio of 35-40:1

- \* Electronic engine flow
- \* Compression system variable geometry blades
- \* Expected gearbox efficiency of 99% with mean time between unscheduled removals (MTBUR) to be 30,000 hrs. (compared to 8,000 hrs. with old technology).
- \* Engine exhausts circumferentially around the engine upstream of the propfan plane
- \* A hub exhaust concept is being examined
- \* Expect a production engine development program in 1988.

## 2.5. Propulsion System Selected

The propulsion system selected for the family of commuters was unducted propfans taken from the Advanced Propfan Engine Technology (APET) report by Allison Gas Turbine Division (Reference 7). The main reasons why the propfan was chosen over the other concepts suggested are as follows:

1. In ungeared systems, the fan and turbine are directly connected and run at the same speed. The result is that fan speed is too low to achieve optimum propulsive efficiency. However, this loss may be compensated for by the weight savings achieved by gearbox elimination. (AWST April 13, 1987)
2. A geared system allows an engine's propfan to be mounted at the front of the engine in a tractor configuration, or at the rear of the engine for a pusher configuration; something that can't be done in a gearless system. (AWST April 13, 1987)
3. The APET concept can be designed for various applications over a range of 6,000 to 18,000 shp. It is not known if the GE UDF concept has proposed entering into the lower horsepower market.

### 3. Propeller Design and Performance

Counter-rotating propfans based on Reference 8 were chosen for the family of commuters. Single rotating propfans were studied, but counter-rotation offered the following advantages (based on propfans of similar horsepower, tip speed, and loading):

\* Counter-rotation delivers 7.9% more total thrust at 7.5% less thrust specific fuel consumption (TSFC) in a maximum climb configuration to 0.7 Mach, 35,000 ft.

\* Counter-rotation operates at 7.6% less TSFC at 0.7 Mach, 35,000 ft.

The geometries of the propfans chosen for the two engine configurations are given in Table 1.

Table 1. Propfan Geometries.

5,500 shp engine: 120 inch diameter fan  
11,000 shp engine: 172 inch diameter fan

Counter Rotation	Aft Tip Sweep = 40 degrees
Blades = 12 (6x6)	Tip Speed = 750 fps
Disk Spacing = 0.18D	Max. Nacelle Diameter = 0.25D
Activity Factor = 180	Integrated Camber = 0.31

Table 2 lists the counter-rotation propfans' performance summary. Figure 4 shows how the efficiency for the various designs compare at Mach = 0.70, 30,000 ft.. Table 3 provides a weight summary of the counter-rotation blades.

Table 2. Counter-Rotation Performance Summary.

Pass.	Flight Condition	Engine shp	Propfan Diameter ft.	Power Loading shp/ft <sup>2</sup>	Cruise $\eta_{NET}$ %
25	1	3,029	10.0	30.29	87
	2	2,790	10.0	27.90	
	3	2,116	10.0	21.16	
36	1	3,519	10.0	35.19	88
	2	3,241	10.0	32.41	
	3	2,458	10.0	24.58	
50	1	4,302	10.0	43.02	89
	2	3,963	10.0	39.63	
	3	3,006	10.0	30.06	
75	1	8,612	14.3	41.92	89
	2	7,933	14.3	38.61	
	3	6,020	14.3	29.30	
100	1	8,612	14.3	41.92	89
	2	7,933	14.3	38.61	
	3	6,020	14.3	29.30	

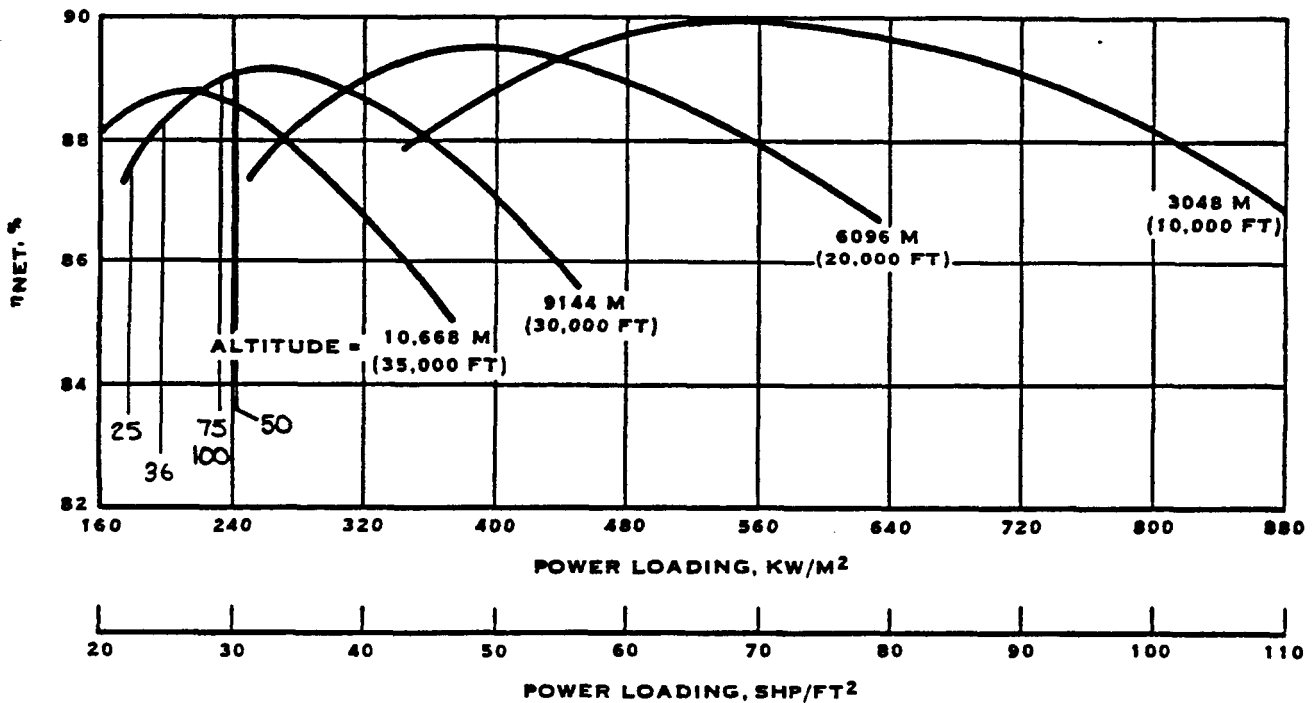

EFFICIENCY AT MACH = 0.70, STD. DAY (NASA CR-168258)

Figure 4. Propfan Efficiencies at Cruise.

Table 3. Propeller Weight Summary.

5,500 shp Fan Weight: 930 lbs.  
11,000 shp Fan Weight: 2,218 lbs.

This weight includes:

* blades	* hub
* retention actuator	* controls
* spinner	* deicing

#### 4. Engine Design and Performance

Two engine cores were developed for the family of commuters: a 5,500 shp core and an 11,000 shp core. This was the best way to meet the performance requirements over the broad spectrum of power settings required for the family. Each airplane has two aft-mounted engines due to commonality considerations. Their power configurations are given in Table 4.

Table 4. Power Configurations for the Family of Commuters.

Airplane	Engines
25 Passenger	2 x 5,500 shp -- derated 30%
36 Passenger	2 x 5,500 shp -- derated 20%
50 Passenger	2 x 5,500 shp
75 Passenger	2 x 11,000 shp
100 Passenger	2 x 11,000 shp

The 25 and 36 passenger engines were derated for stability and control reasons. However, they still meet all performance requirements (including a 3,000 fpm rate of climb at sea level).

The information in this chapter is based on data in Reference 7. The overall engine design, performance, weight and cost are addressed.

#### 4.1. Design Specifications

The engines selected are PD436-11 turboprop engines presented in Reference 7. The design specifications of these engines are outlined in Table 5.

Table 5. Design Specifications of the APET PD436-11 Turboprop Engines.

Size - shp	5,500	11,000
Overall Pressure Ratio	32.5:1	32.5:1
Turbine Temperature - °F	2200 cruise 2500 takeoff	2200 cruise 2500 takeoff
Compressor	Axial/Axial	Axial/Axial
Turbine	HP/LP/Power	HP/LP/Power
Number of Stages:		
LP Compressor	6	6
HP Compressor	7	7
LP Turbine	1	1
HP Turbine	1	1
Power Turbine	3	3

Figure 5 shows the engine general arrangement drawing.

ORIGINAL PAGE IS  
OF POOR QUALITY.

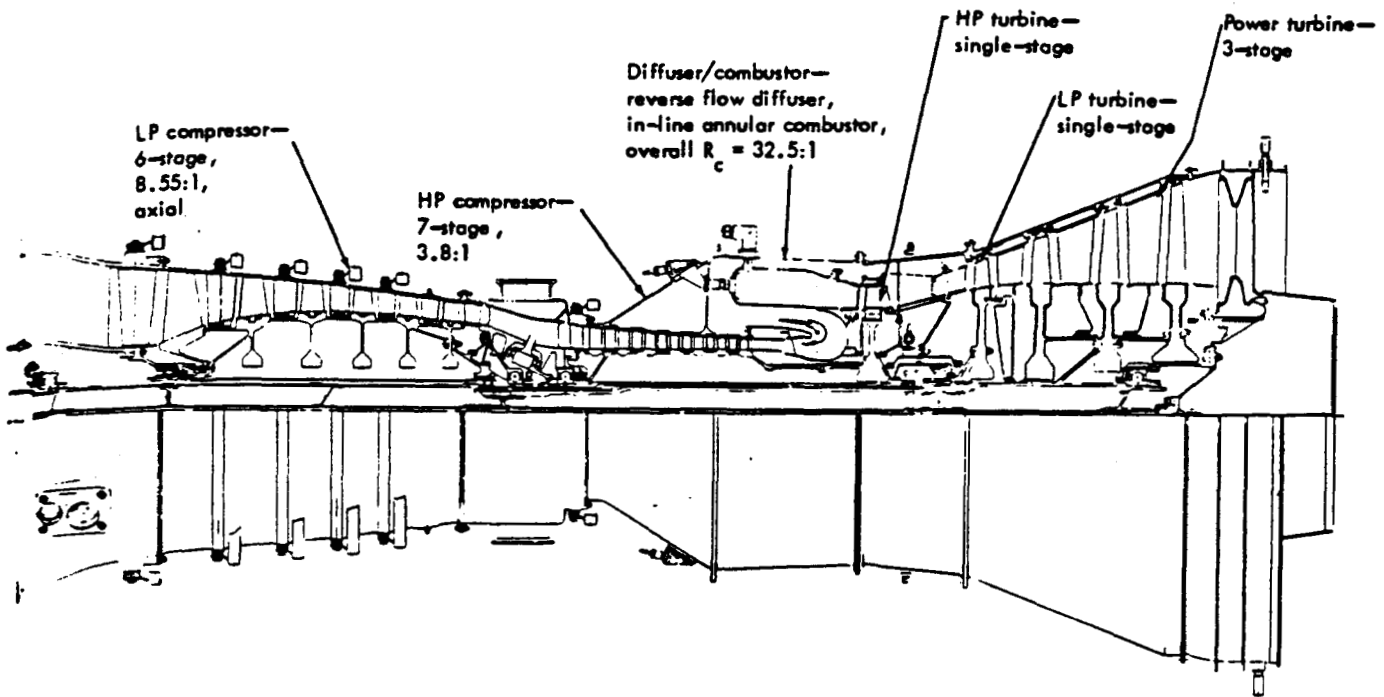

Figure 5. PD436-11 Engine General Arrangement (NASA CR-168115).

#### 4.2. Engine Component Description

The following is a brief description of the engine inlet, compressors, combustor, turbines, and nozzle.

##### 4.2.1. Inlet

The inlets were sized by assuming the total pressure remains constant from inlet to compressor face. A total pressure recovery coefficient of 0.6 was assumed. Table 6 gives the preliminary design specifications of the inlet.

Table 6. Inlet Preliminary Design Specifications.

Engine - shp	5,500	11,000
Compressor face diameter - in.	17.6	24.9
Compressor inlet area - sq. in.	265	446
Inlet area - sq. in.	167	281
Inlet diameter - in.	14.6	18.9
Inlet length - in.	24.6	34.6

#### 4.2.2. Compressors

Figure 6 gives a schematic of the low pressure (LP) axial compressor for the PD436-11 engines. The design goals of the LP compressor are as follows:

- \* corrected flow = 8.8 lb/sec
- \* pressure ratio = 8.55:1
- \* adiabatic efficiency = 86.7%
- \* polytropic efficiency = 90%
- \* hub/tip ratio = 0.52

Figure 7 shows the PD436-11 high pressure (HP) axial compressor. The design goals are as follows:

- \* corrected flow = 8.8 lb/sec
- \* pressure ratio = 3.8:1
- \* adiabatic efficiency = 85.7%
- \* polytropic efficiency = 88.1%
- \* hub/tip ratio = 0.74

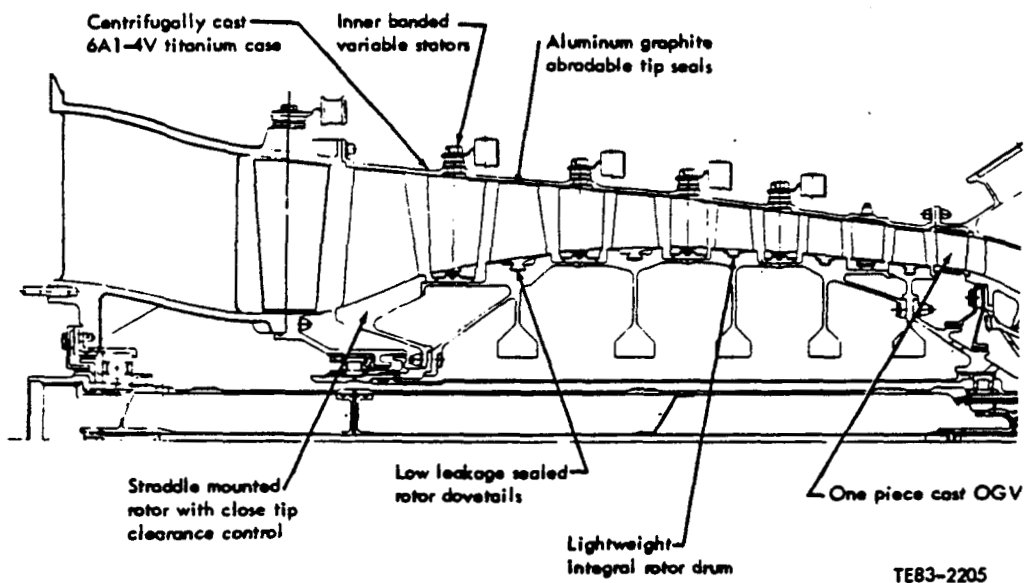

Figure 6. PD436-11 Low Pressure Axial Compressor (NASA CR-168115).



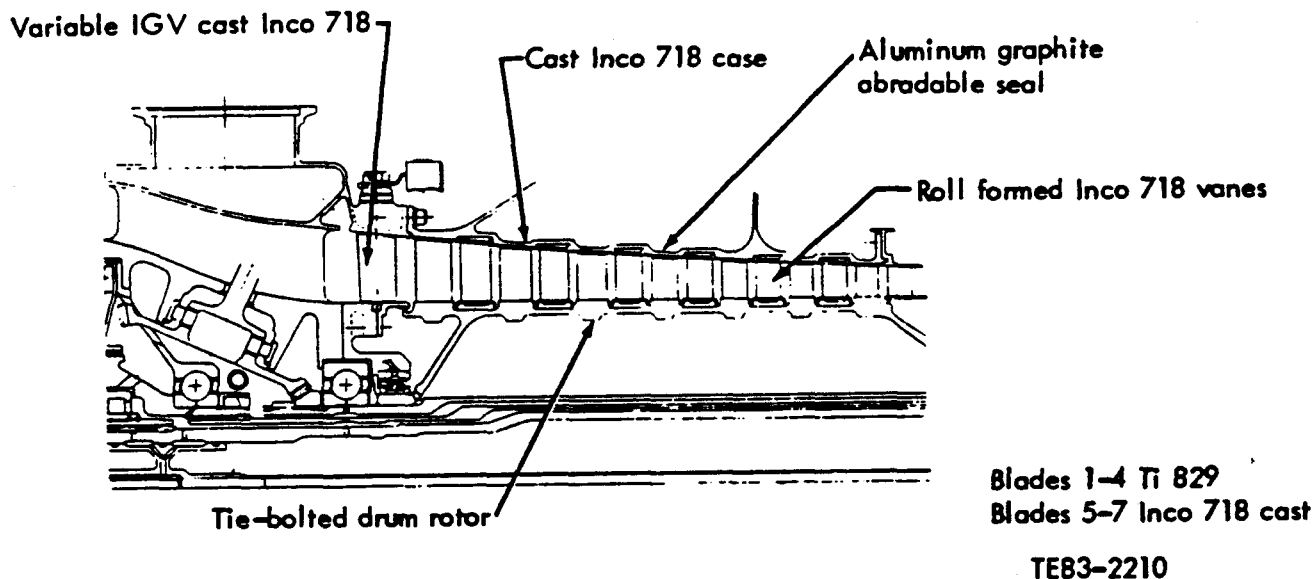

Figure 7. PD436-11 High Pressure Axial Compressor (NASA CR-168115).

#### 4.2.3. Axial Combustor

The axial combustor used for the PD436-11 engine is shown in Figure 8. Notice the combustor has a reverse diffuser to turn the compressor flow 180 degrees before it enters the combustor inlet plenum. This ensures the combustor is supplied with low velocity, high static pressure air. The design goals are:

- \* corrected flow = 43.1 lb/sec
- \* inlet temperature = 1060 °F
- \* burner outlet temperature = 2558 °F
- \* fuel to air ratio = 0.024
- \* pressure change = 5.0%
- \* heat release =  $5.7 \times 10^6$  Btu/ft<sup>3</sup> - atmos - hr
- \* efficiency = 99.9%

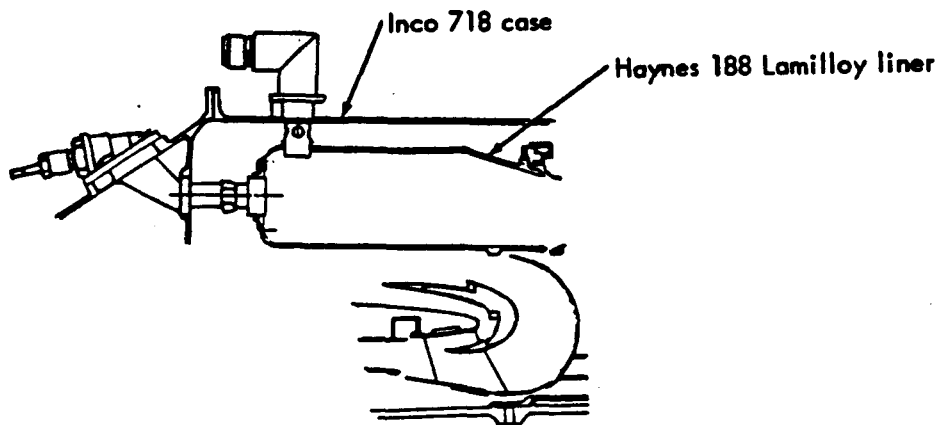

Figure 8. PD436-11 Axial Combustor (NASA CR-168115).

#### 4.2.4. Turbines

The PD436-11 has high pressure, low pressure, and power turbine sections which run the high pressure compressor, low pressure compressor, and propfan respectively. Table 7 outlines their aerodynamic design point conditions for 0.72 Mach, 32,000 ft.

Table 7. Turbine Aerodynamic Design Points.

0.72 Mach, 32,000 ft.

##### High Pressure Turbine

Single stage	
Turbine inlet temperature - °F	2200
Turbine inlet total pressure - psia	173.7
Rotational speed - rpm	2700
Expansion ratio	2.31
Goal efficiency	0.870

##### Low Pressure Turbine

Single stage	
Turbine inlet temperature - °F	1768
Turbine inlet total pressure - psia	75.0
Rotational speed - rpm	17,500
Expansion ratio	2.42
Goal efficiency	0.882

##### Power Turbine

Three stages	
Turbine inlet temperature - °F	1384
Turbine inlet total pressure - psia	31.0
Rotational speed - rpm	10,750
Expansion ratio	5.93
Goal efficiency	0.915

The high and low pressure turbine blades are air cooled. Figure 9 shows a schematic of each of the turbine sections.

#### 4.2.5. Nozzle

The nozzles for this design will be annular. The exhaust gases will be mixed with the airflow ahead of the propfan plane of rotation. The main reason for this selection is it allows the exhaust to pass outside the gearbox without increasing nacelle diameter. It is proposed that the following exhaust areas will be required:

5,500 shp engine:	178 sq. in.
11,000 shp engine:	358 sq. in.

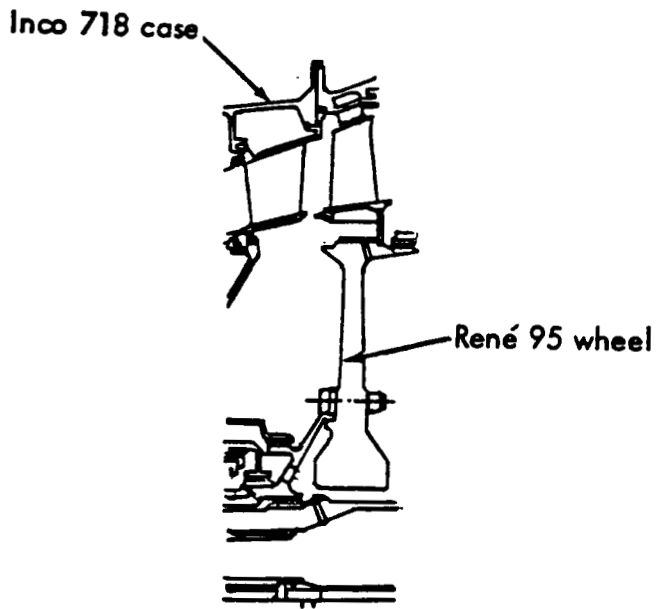

a) Low Pressure Turbine

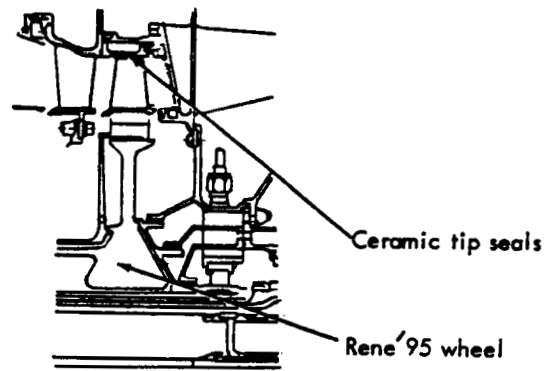

b) High Pressure Turbine

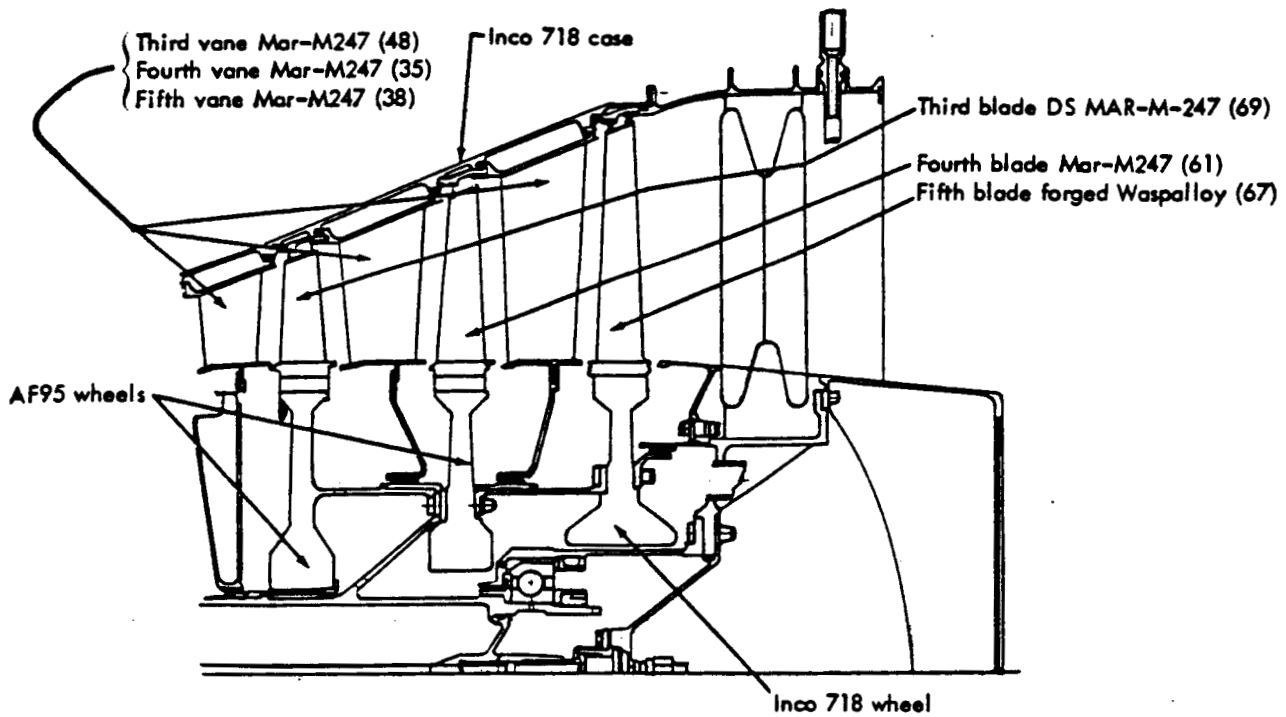

c) Power Turbine

Figure 9. PD436-11 Turbine Sections (NASA CR-168115).

### 4.3. Engine Accessories

The PD436-11 engine is designed to accommodate the engine and aircraft accessories outlined in Table 8.

Table 8. Engine and Aircraft Accessories.

Accessories driven by the power section gearbox:

- \* fuel module
- \* oil pump
- \* permanent magnet generator
- \* starter
- \* air/oil separator

Accessories driven by the propfan gearbox:

- \* oil pump
- \* prop regulator
- \* two aircraft hydraulic pumps
- \* aircraft mounted accessories drive system (AMADS)
- \* prop brake
- \* aircraft alternator

The propfan propulsion system utilizes a full authority digital electronic control.

### 4.4. Engine Outline Drawing

Figures 10 and 11 present the outline drawings for the PD436-11 5,500 shp and 11,000 shp engines respectively. These layouts differ from those proposed in Reference 2; the gearbox has been placed behind the engine core to allow for a pusher configuration.

### 4.5. Gearbox Design

The counter-rotation gearboxes were designed to provide a gearing ratio of approximately 8.1. The power section rotational speed will be 10,750 rpm and the propfan rotational speed will be approximately 1330 rpm. Efficiencies of 98.8% to 99.3% are estimated for the gearboxes at take-off conditions.

The gearboxes shown in Figures 10 and 11 resemble those proposed for single rotation configurations. The counter rotation designs are slightly longer but more compact. Figure 12 is an example. The actual gearbox design is yet to be determined. For preliminary design purposes, the larger gearbox was chosen to ensure the gearbox space required is provided for in the layout; therefore, there is a good possibility the nacelle diameter could be reduced with advanced gearbox technology. Weight and costs may also be reduced.

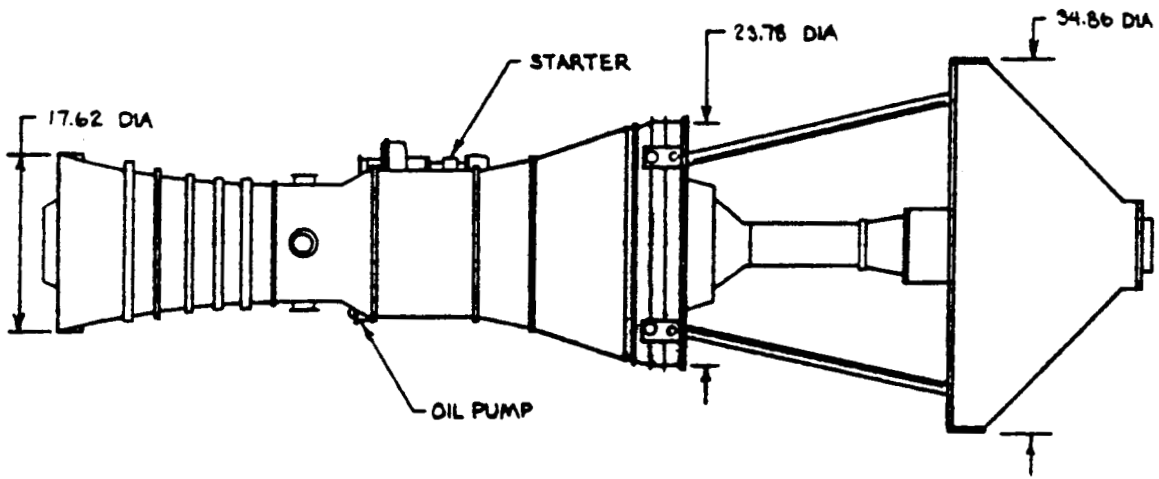

TDP

NOTE: ALL DIMENSIONS IN INCHES.

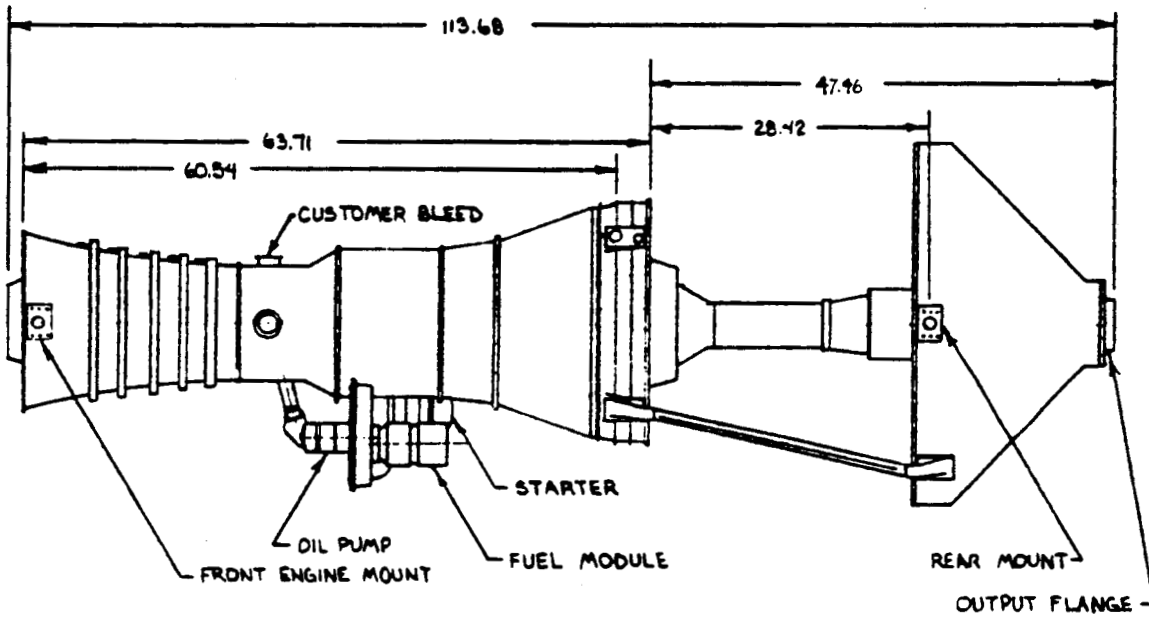

LEFT SIDE

Figure 10. 5,500 shp PD436-11 Derivative Outline Drawing.

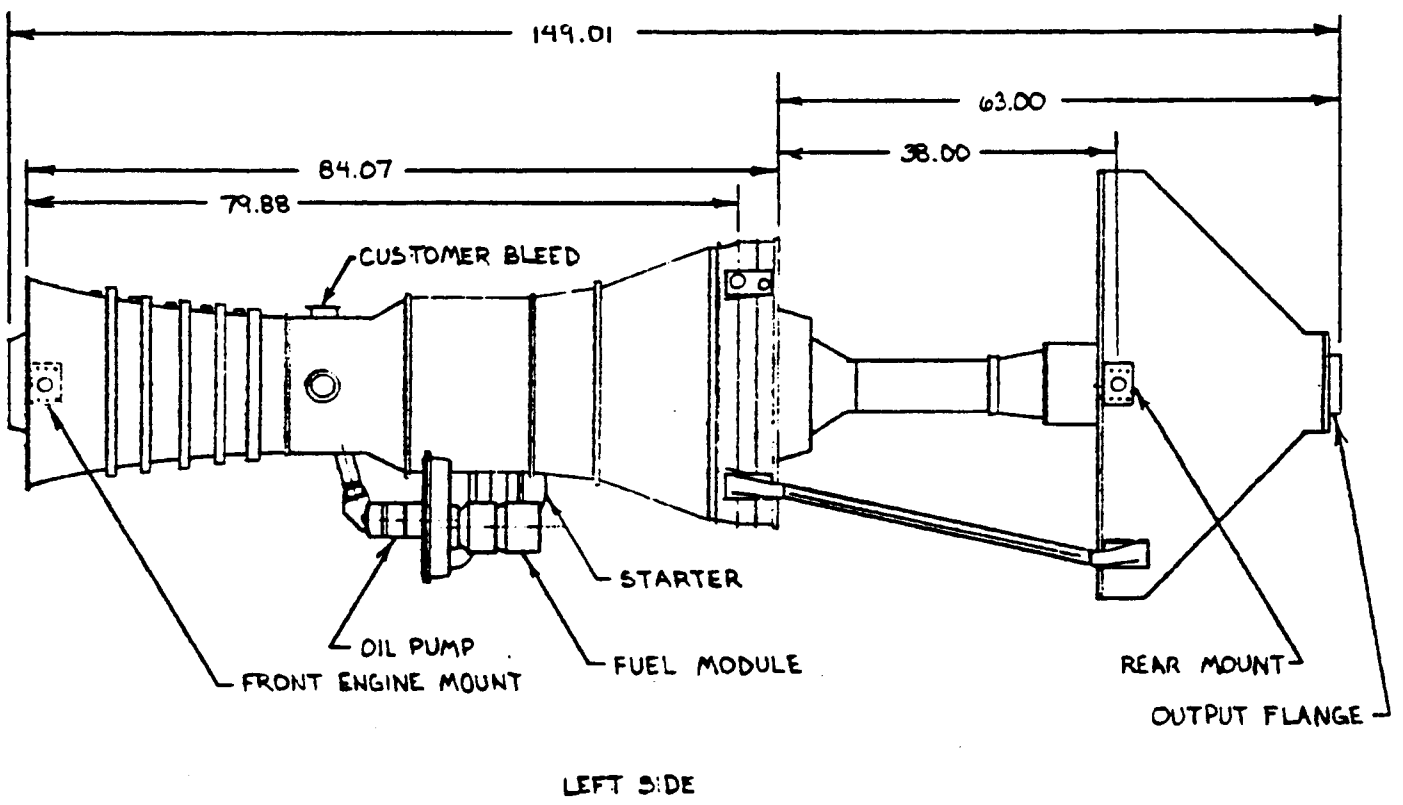
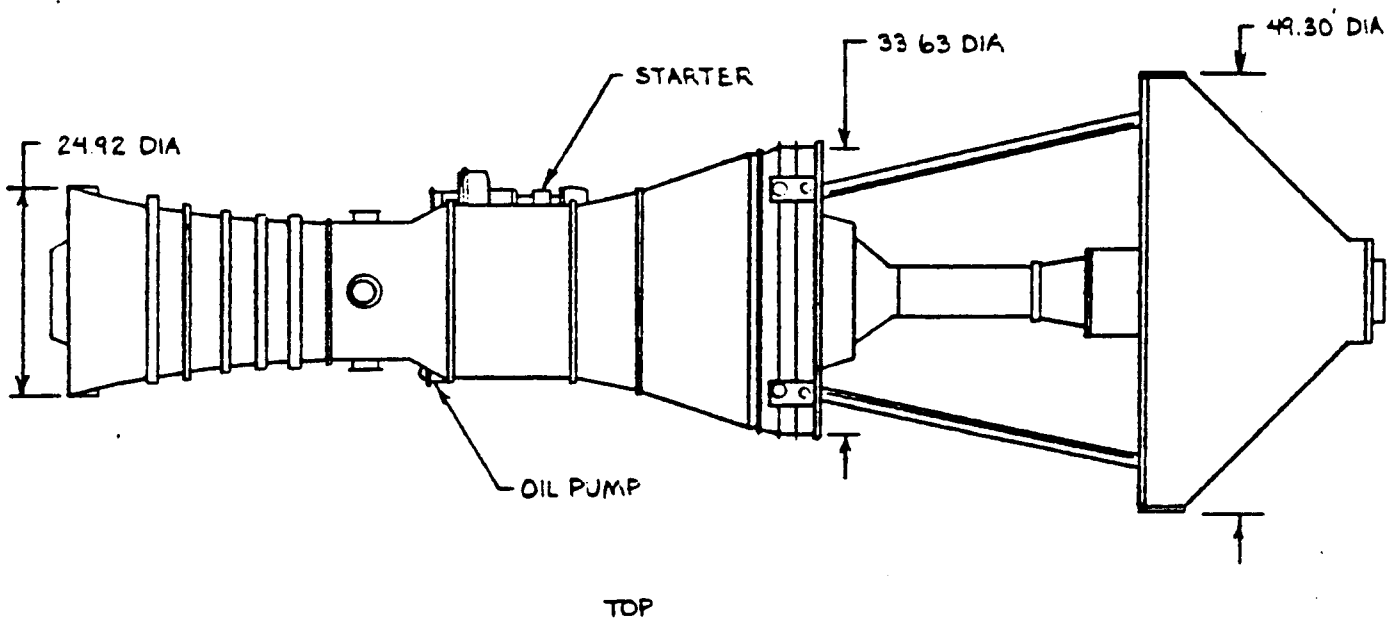

Figure 11. 11,000 shp PD436-11 Derivative Outline Drawing.

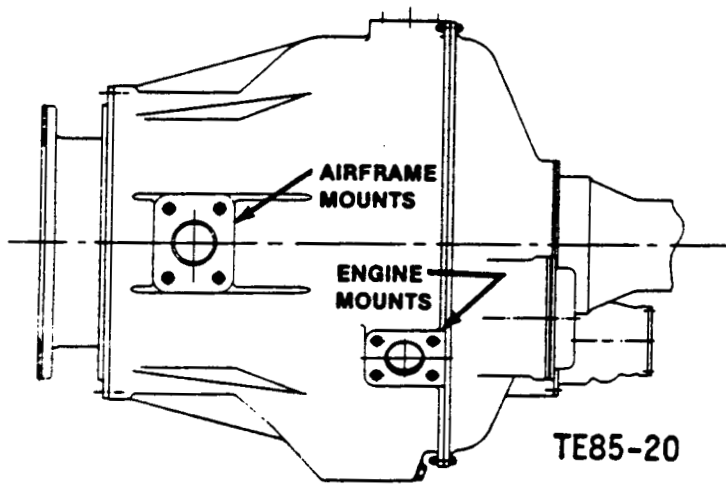

Figure 12. Counter-Rotation Gearbox (NASA CR-168115).

#### 4.6. Installed Performance

Tables 9 - 13 summarize the installed performance characteristics of the family of commuters. Figures 13 - 22 are the related graphs. The 25 and 36 passenger engines were derated 30% and 20% respectively for stability and control reasons. Derating may be achieved by providing a throttle regulator in the electronic engine controls. The cockpit layout will not be altered. An advantage to derating the 25 and 36 passenger engines is that their service life will be increased. Table 14 is a short summary of the design point performances.

#### 4.7. Weight

Tables 15 - 19 provide a component breakdown of the engine weights. Figure 23 locates the propulsion system center of gravity.

#### 4.8. Costs

The proposed costs for the propulsion system are given in Table 20.



Table 9. 25 Passenger Installed Performance Summary.

INSTALLED POWER FOR  
THE  
25.00 PASS.

INPUTS:

T.O. Weight: 28,506.00 lbs.  
 Fuel Weight: 3,767.00 lbs.  
 Wing Area: 592.00 sq. ft.

DRAG POLAR:

	Landing	Climb	Cruise
Cdo:	1.61E-01	1.29E-02	1.29E-02
1/(p)Ae:	3.08E-02	3.09E-02	3.09E-02

POWER AVAILABLE:

At Sea Level:

At 30,000 ft.:

Speed (kts)	Preq-L (shp)	Pavl-L (shp)	Speed (kts)	Preq-cr (shp)	Pavl-cr (shp)
0.10	1,121.27	7,618.75	0.50	1,562.96	3,849.20
0.20	3,347.34	6,057.65	0.60	2,300.96	4,028.60
0.30	10,282.06	6,176.73	0.70	3,381.65	4,231.66
0.40	23,967.35	6,341.62	0.75	4,064.60	4,339.29
			0.80	4,850.64	4,451.51

At 10,000 ft.:

0.20	685.49	5,316.41
0.30	884.28	5,426.34
0.40	1,525.99	5,579.78
0.50	2,676.18	5,772.91



ORIGINAL PAGE IS  
OF POOR QUALITY

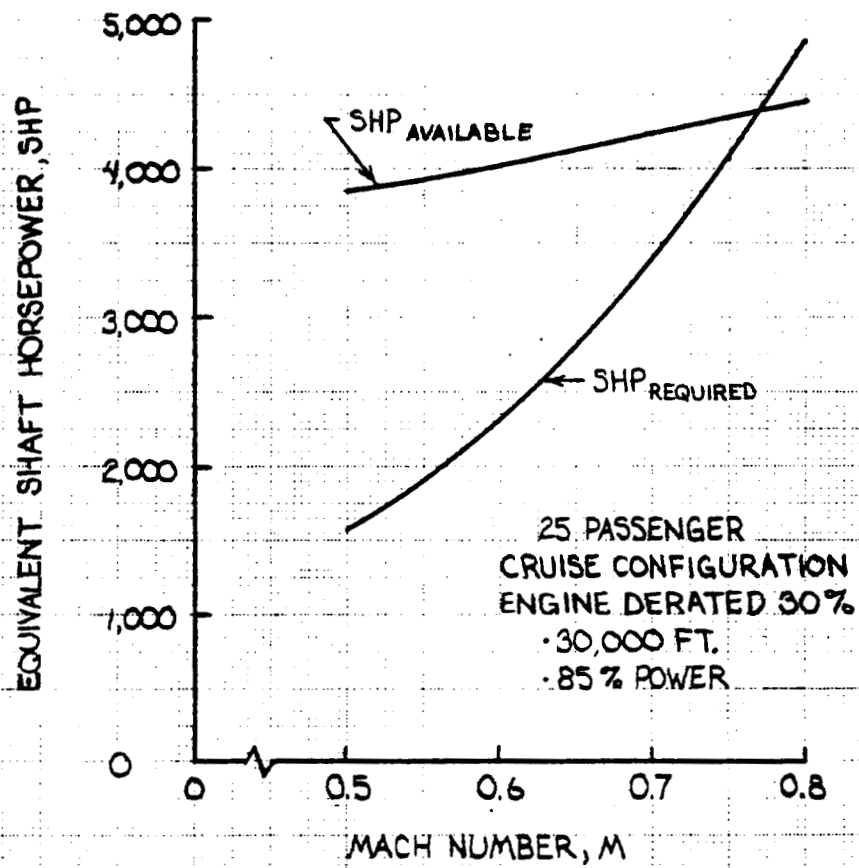

<table border="1"> <tr> <td>CALC</td> <td>G. SWIFT</td> <td>4-29</td> <td>REVISED</td> <td>DATE</td> </tr> <tr> <td>CHECK</td> <td></td> <td></td> <td></td> <td></td> </tr> <tr> <td>APPD</td> <td></td> <td></td> <td></td> <td></td> </tr> <tr> <td>APPD</td> <td></td> <td></td> <td></td> <td></td> </tr> </table>	CALC	G. SWIFT	4-29	REVISED	DATE	CHECK					APPD					APPD					<p>FIGURE 14. 25 PASSENGER CRUISE POWER CURVE.</p>	<p>AE 790</p>
CALC	G. SWIFT	4-29	REVISED	DATE																		
CHECK																						
APPD																						
APPD																						
<p>ROSKAM AVIATION AND ENGINEERING CORPORATION</p>		<p>PAGE 22</p>																				

Table 10. 36 Passenger Installed Performance Summary.

INSTALLED POWER FOR  
THE  
36.00 PASS.

INPUTS:

T.O. Weight: 35,954.00 lbs.  
 Fuel Weight: 5,620.00 lbs.  
 Wing Area: 592.00 sq. ft.

DRAG POLAR:

	Landing	Climb	Cruise
Cdo:	1.69E-01	1.60E-02	1.60E-02
1/(pi)Ae:	3.08E-02	3.09E-02	3.09E-02

POWER AVAILABLE:

At Sea Level:

Speed (kts)	Preq-L (shp)	Pavl-L (shp)
0.10	1,581.95	8,850.00
0.20	3,710.71	7,037.11
0.30	10,908.61	7,175.40
0.40	25,213.27	7,366.89

At 30,000 ft.:

Speed (kts)	Preq-cr (shp)	Pavl-cr (shp)
0.50	2,076.93	4,472.46
0.60	2,969.21	4,680.79
0.70	4,293.14	4,916.60
0.75	5,133.61	5,041.60
0.80	6,102.79	5,171.91

At 10,000 ft.:

0.20	1,035.19	6,176.32
0.30	1,220.09	6,303.97
0.40	1,985.19	6,482.16
0.50	3,393.29	6,706.44

ORIGINAL PAGE IS  
OF POOR QUALITY

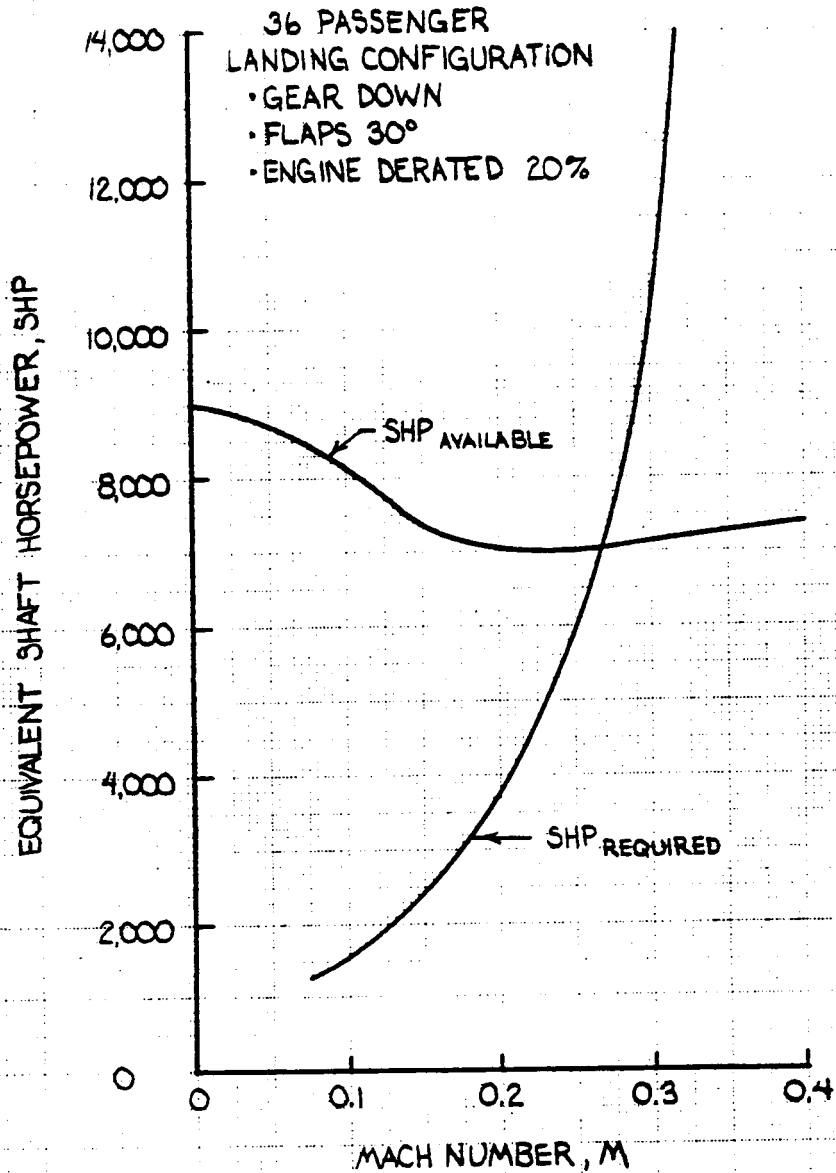

<table border="1"> <tr> <td> <table border="1"> <tr> <td> <table border="1"> <tr> <td>CALC</td> <td>G. SWIFT</td> <td>4-29</td> <td>REVISED</td> <td>DATE</td> </tr> <tr> <td>CHECK</td> <td></td> <td></td> <td></td> <td></td> </tr> <tr> <td>APPD</td> <td></td> <td></td> <td></td> <td></td> </tr> <tr> <td>APPD</td> <td></td> <td></td> <td></td> <td></td> </tr> </table> </td> <td colspan="4">                 FIGURE 15. 36 PASSENGER LANDING POWER CURVE.             </td> <td>AE 790</td> </tr> <tr> <td colspan="5">                 ROSKAM AVIATION AND ENGINEERING CORPORATION             </td> <td>PAGE 24</td> </tr> </table> </td> </tr> </table>	<table border="1"> <tr> <td> <table border="1"> <tr> <td>CALC</td> <td>G. SWIFT</td> <td>4-29</td> <td>REVISED</td> <td>DATE</td> </tr> <tr> <td>CHECK</td> <td></td> <td></td> <td></td> <td></td> </tr> <tr> <td>APPD</td> <td></td> <td></td> <td></td> <td></td> </tr> <tr> <td>APPD</td> <td></td> <td></td> <td></td> <td></td> </tr> </table> </td> <td colspan="4">                 FIGURE 15. 36 PASSENGER LANDING POWER CURVE.             </td> <td>AE 790</td> </tr> <tr> <td colspan="5">                 ROSKAM AVIATION AND ENGINEERING CORPORATION             </td> <td>PAGE 24</td> </tr> </table>	<table border="1"> <tr> <td>CALC</td> <td>G. SWIFT</td> <td>4-29</td> <td>REVISED</td> <td>DATE</td> </tr> <tr> <td>CHECK</td> <td></td> <td></td> <td></td> <td></td> </tr> <tr> <td>APPD</td> <td></td> <td></td> <td></td> <td></td> </tr> <tr> <td>APPD</td> <td></td> <td></td> <td></td> <td></td> </tr> </table>	CALC	G. SWIFT	4-29	REVISED	DATE	CHECK					APPD					APPD					FIGURE 15. 36 PASSENGER LANDING POWER CURVE.				AE 790	ROSKAM AVIATION AND ENGINEERING CORPORATION					PAGE 24
<table border="1"> <tr> <td> <table border="1"> <tr> <td>CALC</td> <td>G. SWIFT</td> <td>4-29</td> <td>REVISED</td> <td>DATE</td> </tr> <tr> <td>CHECK</td> <td></td> <td></td> <td></td> <td></td> </tr> <tr> <td>APPD</td> <td></td> <td></td> <td></td> <td></td> </tr> <tr> <td>APPD</td> <td></td> <td></td> <td></td> <td></td> </tr> </table> </td> <td colspan="4">                 FIGURE 15. 36 PASSENGER LANDING POWER CURVE.             </td> <td>AE 790</td> </tr> <tr> <td colspan="5">                 ROSKAM AVIATION AND ENGINEERING CORPORATION             </td> <td>PAGE 24</td> </tr> </table>	<table border="1"> <tr> <td>CALC</td> <td>G. SWIFT</td> <td>4-29</td> <td>REVISED</td> <td>DATE</td> </tr> <tr> <td>CHECK</td> <td></td> <td></td> <td></td> <td></td> </tr> <tr> <td>APPD</td> <td></td> <td></td> <td></td> <td></td> </tr> <tr> <td>APPD</td> <td></td> <td></td> <td></td> <td></td> </tr> </table>	CALC	G. SWIFT	4-29	REVISED	DATE	CHECK					APPD					APPD					FIGURE 15. 36 PASSENGER LANDING POWER CURVE.				AE 790	ROSKAM AVIATION AND ENGINEERING CORPORATION					PAGE 24	
<table border="1"> <tr> <td>CALC</td> <td>G. SWIFT</td> <td>4-29</td> <td>REVISED</td> <td>DATE</td> </tr> <tr> <td>CHECK</td> <td></td> <td></td> <td></td> <td></td> </tr> <tr> <td>APPD</td> <td></td> <td></td> <td></td> <td></td> </tr> <tr> <td>APPD</td> <td></td> <td></td> <td></td> <td></td> </tr> </table>	CALC	G. SWIFT	4-29	REVISED	DATE	CHECK					APPD					APPD					FIGURE 15. 36 PASSENGER LANDING POWER CURVE.				AE 790								
CALC	G. SWIFT	4-29	REVISED	DATE																													
CHECK																																	
APPD																																	
APPD																																	
ROSKAM AVIATION AND ENGINEERING CORPORATION					PAGE 24																												

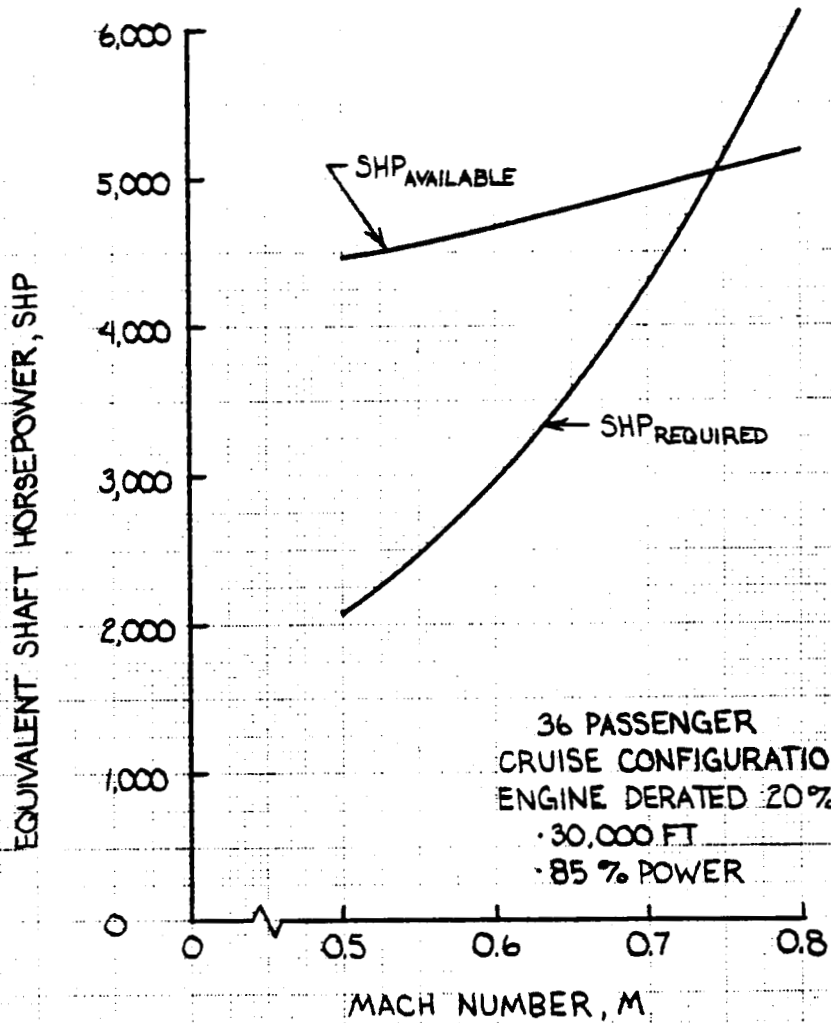

<table border="1"> <tr> <td>CALC</td> <td>G. SWIFT</td> <td>4-29</td> <td>REVISED</td> <td>DATE</td> </tr> <tr> <td>CHECK</td> <td></td> <td></td> <td></td> <td></td> </tr> <tr> <td>APPD</td> <td></td> <td></td> <td></td> <td></td> </tr> <tr> <td>APPD</td> <td></td> <td></td> <td></td> <td></td> </tr> </table>	CALC	G. SWIFT	4-29	REVISED	DATE	CHECK					APPD					APPD					FIGURE 16. 36 PASSENGER CRUISE POWER CURVE.	AE 790
CALC	G. SWIFT	4-29	REVISED	DATE																		
CHECK																						
APPD																						
APPD																						
ROSKAM AVIATION AND ENGINEERING CORPORATION		PAGE 25																				

Table 11. 50 Passenger Installed Performance Summary.

INSTALLED POWER FOR  
THE  
50.00 PASS.

INPUTS:

T.O. Weight: 43,141.00 lbs.  
 Fuel Weight: 6,913.00 lbs.  
 Wing Area: 592.00 sq. ft.

DRAG POLAR:

	Landing	Climb	Cruise
Cdo:	2.03E-01	1.56E-02	1.56E-02
1/(pi)Ae:	3.08E-02	3.09E-02	3.09E-02

POWER AVAILABLE:

At Sea Level:

Speed (kts)	Preq-L (shp)	Pavl-L (shp)
0.10	2,184.50	10,820.00
0.20	4,597.66	8,604.24
0.30	13,191.87	8,773.27
0.40	30,342.16	9,007.30

At 30,000 ft.:

Speed (kts)	Preq-cr (shp)	Pavl-cr (shp)
0.50	2,342.68	5,469.68
0.60	3,159.71	5,724.30
0.70	4,412.72	6,012.51
0.75	5,217.05	6,165.28
0.80	6,148.76	6,324.56

At 10,000 ft.:

0.20	1,399.48	7,552.16
0.30	1,449.70	7,708.19
0.40	2,130.64	7,925.97
0.50	3,464.52	8,200.10

ORIGINAL PAGE IS  
OF POOR QUALITY

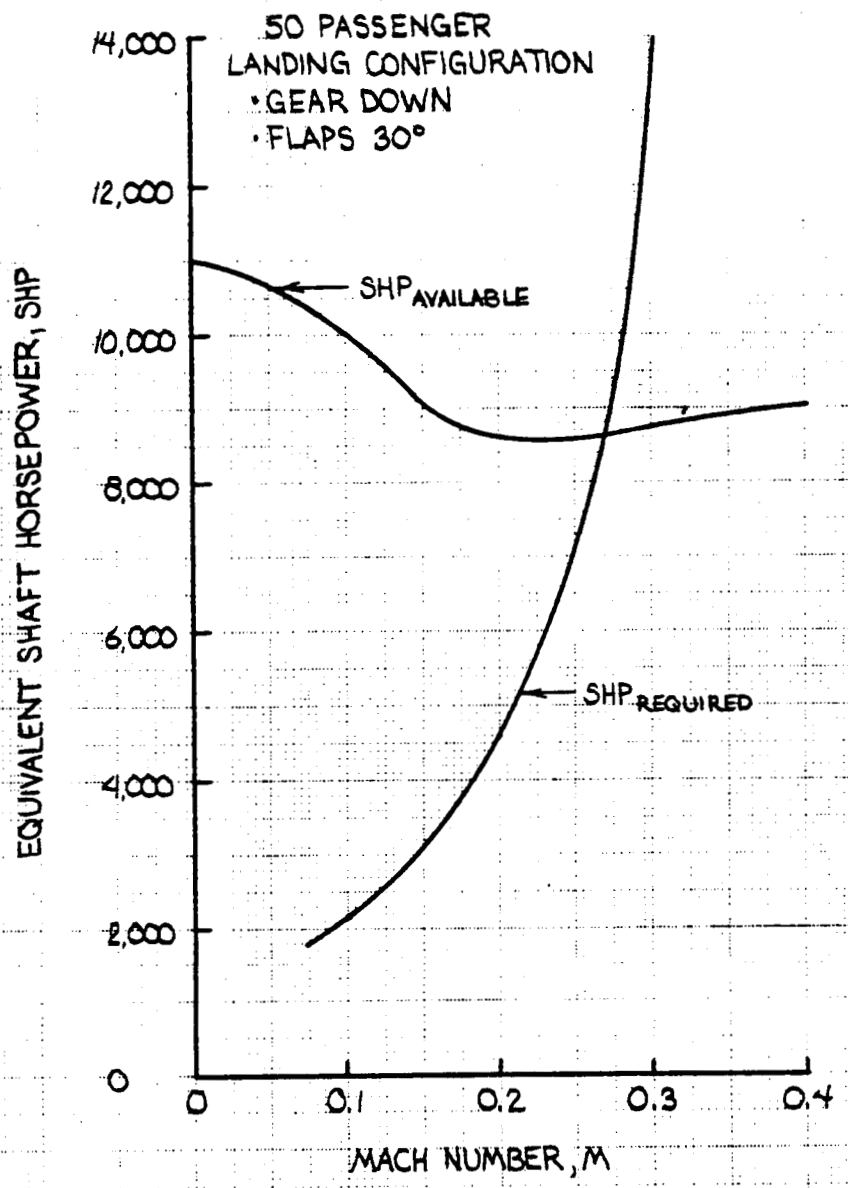

CALC	G. SWIFT	4-29	REVISED	DATE
CHECK				
APPD				
APPD				

FIGURE 17. 50 PASSENGER  
LANDING POWER CURVE.

ROSKAM AVIATION AND ENGINEERING CORPORATION





Table 12. 75 Passenger Installed Performance Summary.

INSTALLED POWER FOR  
THE  
75.00 PASS.

INPUTS:

T.O. Weight: 71,419.00 lbs.  
 Fuel Weight: 11,240.00 lbs.  
 Wing Area: 1.182.00 sq. ft.

DRAG POLAR:

	Landing	Climb	Cruise
Cdo:	2.22E-01	1.39E-02	1.39E-02
1/(pi)Ae:	2.40E-02	2.53E-02	2.53E-02

POWER AVAILABLE:

At Sea Level:

At 30,000 ft.:

Speed (kts)	Preq-L (shp)	Pavl-L (shp)
0.10	2,859.46	21,655.00
0.20	9,101.37	17,223.49
0.30	28,230.08	17,561.54
0.40	65,923.77	18,029.61

Speed (kts)	Preq-cr (shp)	Pavl-cr (shp)
0.50	3,520.58	10,954.35
0.60	5,081.96	11,463.60
0.70	7,388.16	12,040.02
0.75	8,849.92	12,345.57
0.80	10,534.43	12,664.12

At 10,000 ft.:

0.20	1,697.82	15,119.33
0.30	2,051.14	15,431.38
0.40	3,394.54	15,866.94
0.50	5,846.76	16,415.19

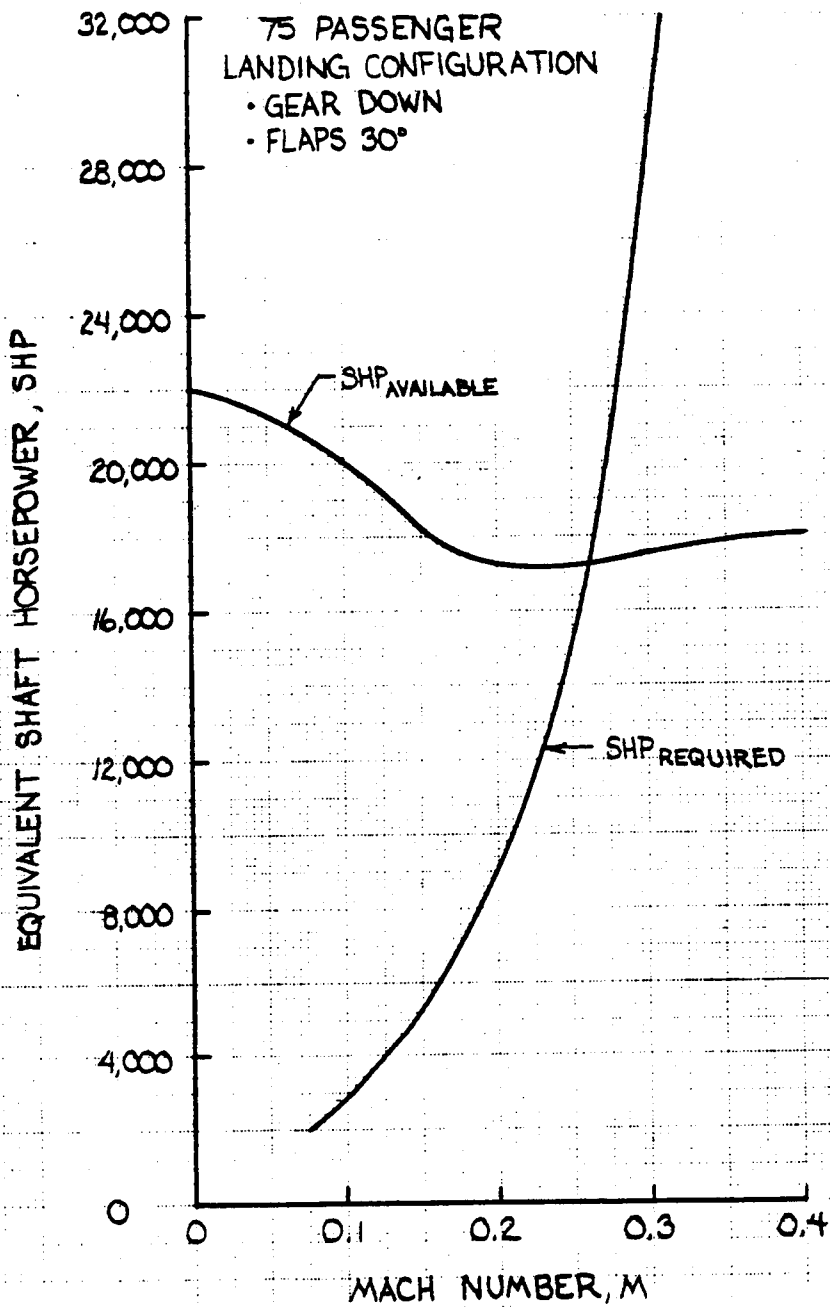

<table border="1"> <tr> <td> <table border="1"> <tr> <td> <table border="1"> <tr> <td>CALC</td> <td>G. SWIFT</td> <td>4-29</td> <td>REVISED</td> <td>DATE</td> </tr> <tr> <td>CHECK</td> <td></td> <td></td> <td></td> <td></td> </tr> <tr> <td>APPD</td> <td></td> <td></td> <td></td> <td></td> </tr> <tr> <td>APPD</td> <td></td> <td></td> <td></td> <td></td> </tr> </table> </td> <td colspan="4">           FIGURE 19. 75 PASSENGER LANDING POWER CURVE.         </td> <td>AE 790</td> </tr> <tr> <td colspan="5">           ROSKAM AVIATION AND ENGINEERING CORPORATION         </td> <td>PAGE 30</td> </tr> </table> </td> </tr> </table>	<table border="1"> <tr> <td> <table border="1"> <tr> <td>CALC</td> <td>G. SWIFT</td> <td>4-29</td> <td>REVISED</td> <td>DATE</td> </tr> <tr> <td>CHECK</td> <td></td> <td></td> <td></td> <td></td> </tr> <tr> <td>APPD</td> <td></td> <td></td> <td></td> <td></td> </tr> <tr> <td>APPD</td> <td></td> <td></td> <td></td> <td></td> </tr> </table> </td> <td colspan="4">           FIGURE 19. 75 PASSENGER LANDING POWER CURVE.         </td> <td>AE 790</td> </tr> <tr> <td colspan="5">           ROSKAM AVIATION AND ENGINEERING CORPORATION         </td> <td>PAGE 30</td> </tr> </table>	<table border="1"> <tr> <td>CALC</td> <td>G. SWIFT</td> <td>4-29</td> <td>REVISED</td> <td>DATE</td> </tr> <tr> <td>CHECK</td> <td></td> <td></td> <td></td> <td></td> </tr> <tr> <td>APPD</td> <td></td> <td></td> <td></td> <td></td> </tr> <tr> <td>APPD</td> <td></td> <td></td> <td></td> <td></td> </tr> </table>	CALC	G. SWIFT	4-29	REVISED	DATE	CHECK					APPD					APPD					FIGURE 19. 75 PASSENGER LANDING POWER CURVE.				AE 790	ROSKAM AVIATION AND ENGINEERING CORPORATION					PAGE 30
<table border="1"> <tr> <td> <table border="1"> <tr> <td>CALC</td> <td>G. SWIFT</td> <td>4-29</td> <td>REVISED</td> <td>DATE</td> </tr> <tr> <td>CHECK</td> <td></td> <td></td> <td></td> <td></td> </tr> <tr> <td>APPD</td> <td></td> <td></td> <td></td> <td></td> </tr> <tr> <td>APPD</td> <td></td> <td></td> <td></td> <td></td> </tr> </table> </td> <td colspan="4">           FIGURE 19. 75 PASSENGER LANDING POWER CURVE.         </td> <td>AE 790</td> </tr> <tr> <td colspan="5">           ROSKAM AVIATION AND ENGINEERING CORPORATION         </td> <td>PAGE 30</td> </tr> </table>	<table border="1"> <tr> <td>CALC</td> <td>G. SWIFT</td> <td>4-29</td> <td>REVISED</td> <td>DATE</td> </tr> <tr> <td>CHECK</td> <td></td> <td></td> <td></td> <td></td> </tr> <tr> <td>APPD</td> <td></td> <td></td> <td></td> <td></td> </tr> <tr> <td>APPD</td> <td></td> <td></td> <td></td> <td></td> </tr> </table>	CALC	G. SWIFT	4-29	REVISED	DATE	CHECK					APPD					APPD					FIGURE 19. 75 PASSENGER LANDING POWER CURVE.				AE 790	ROSKAM AVIATION AND ENGINEERING CORPORATION					PAGE 30	
<table border="1"> <tr> <td>CALC</td> <td>G. SWIFT</td> <td>4-29</td> <td>REVISED</td> <td>DATE</td> </tr> <tr> <td>CHECK</td> <td></td> <td></td> <td></td> <td></td> </tr> <tr> <td>APPD</td> <td></td> <td></td> <td></td> <td></td> </tr> <tr> <td>APPD</td> <td></td> <td></td> <td></td> <td></td> </tr> </table>	CALC	G. SWIFT	4-29	REVISED	DATE	CHECK					APPD					APPD					FIGURE 19. 75 PASSENGER LANDING POWER CURVE.				AE 790								
CALC	G. SWIFT	4-29	REVISED	DATE																													
CHECK																																	
APPD																																	
APPD																																	
ROSKAM AVIATION AND ENGINEERING CORPORATION					PAGE 30																												

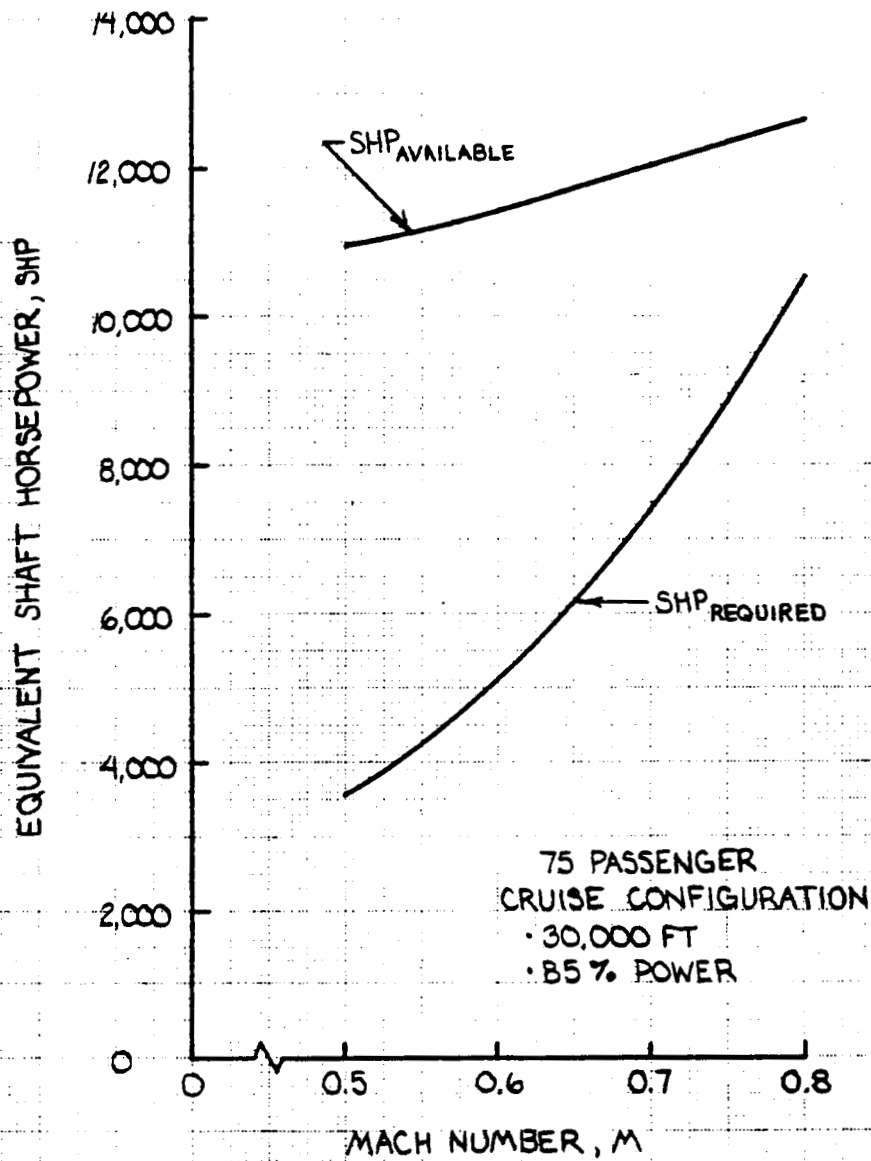

<table border="1"> <tr> <td> <table border="1"> <tr> <td>CALC</td> <td>G. SWIFT</td> <td>4-29</td> <td>REVISED</td> <td>DATE</td> </tr> <tr> <td>CHECK</td> <td></td> <td></td> <td></td> <td></td> </tr> <tr> <td>APPD</td> <td></td> <td></td> <td></td> <td></td> </tr> <tr> <td>APPD</td> <td></td> <td></td> <td></td> <td></td> </tr> </table> </td> <td colspan="3">           FIGURE 20. 75 PASSENGER CRUISE POWER CURVE.         </td> <td>AE 790</td> </tr> <tr> <td colspan="4">           ROSKAM AVIATION AND ENGINEERING CORPORATION         </td> <td>           PAGE 31         </td> </tr> </table>	<table border="1"> <tr> <td>CALC</td> <td>G. SWIFT</td> <td>4-29</td> <td>REVISED</td> <td>DATE</td> </tr> <tr> <td>CHECK</td> <td></td> <td></td> <td></td> <td></td> </tr> <tr> <td>APPD</td> <td></td> <td></td> <td></td> <td></td> </tr> <tr> <td>APPD</td> <td></td> <td></td> <td></td> <td></td> </tr> </table>	CALC	G. SWIFT	4-29	REVISED	DATE	CHECK					APPD					APPD					FIGURE 20. 75 PASSENGER CRUISE POWER CURVE.			AE 790	ROSKAM AVIATION AND ENGINEERING CORPORATION				PAGE 31
<table border="1"> <tr> <td>CALC</td> <td>G. SWIFT</td> <td>4-29</td> <td>REVISED</td> <td>DATE</td> </tr> <tr> <td>CHECK</td> <td></td> <td></td> <td></td> <td></td> </tr> <tr> <td>APPD</td> <td></td> <td></td> <td></td> <td></td> </tr> <tr> <td>APPD</td> <td></td> <td></td> <td></td> <td></td> </tr> </table>	CALC	G. SWIFT	4-29	REVISED	DATE	CHECK					APPD					APPD					FIGURE 20. 75 PASSENGER CRUISE POWER CURVE.			AE 790						
CALC	G. SWIFT	4-29	REVISED	DATE																										
CHECK																														
APPD																														
APPD																														
ROSKAM AVIATION AND ENGINEERING CORPORATION				PAGE 31																										

Table 13. 100 Passenger Installed Performance Summary.

INSTALLED POWER FOR  
THE  
100.00 PASS.

INPUTS:

T.O. Weight: 85,044.00 lbs.  
 Fuel Weight: 13,878.00 lbs.  
 Wing Area: 1,182.00 sq. ft.

DRAG POLAR:

	Landing	Climb	Cruise
Cdo:	2.52E-01	1.45E-02	1.45E-02
1/(pi)Ae:	2.40E-02	2.53E-02	2.53E-02

POWER AVAILABLE:

At Sea Level:

Speed (kts)	Preq-L (shp)	Pavl-L (shp)
0.10	3,761.82	21,655.00
0.20	10,563.24	17,223.49
0.30	32,124.46	17,561.54
0.40	74,740.28	18,029.61

At 30,000 ft.:

Speed (kts)	Preq-cr (shp)	Pavl-cr (shp)
0.50	4,082.14	10,954.35
0.60	5,642.65	11,463.60
0.70	7,999.64	12,040.02
0.75	9,504.99	12,345.57
0.80	11,245.15	12,664.12

At 10,000 ft.:

0.20	2,280.21	15,119.33
0.30	2,479.08	15,431.38
0.40	3,795.62	15,866.94
0.50	6,302.78	16,415.19



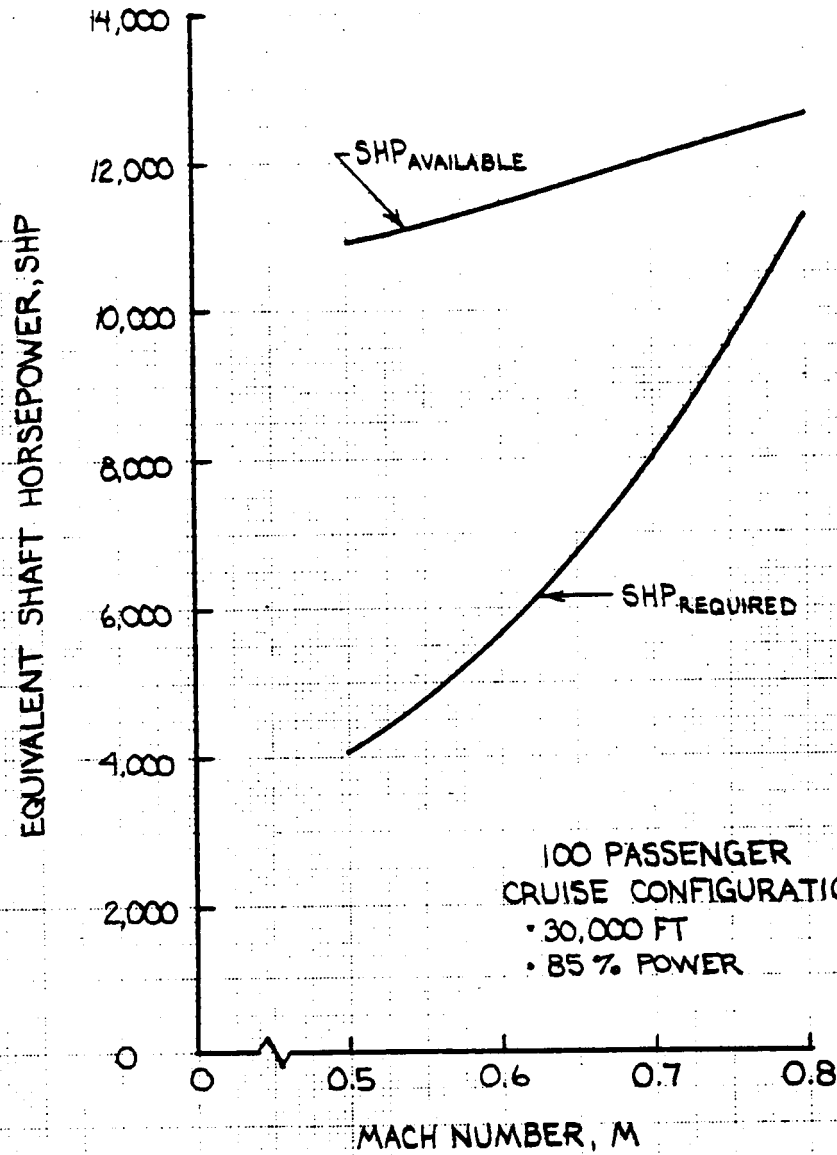

<table border="1"> <tr> <td> <table border="1"> <tr> <td> <table border="1"> <tr> <td>CALC</td> <td>G. SWIFT</td> <td>4-29</td> <td>REVISED</td> <td>DATE</td> </tr> <tr> <td>CHECK</td> <td></td> <td></td> <td></td> <td></td> </tr> <tr> <td>APPD</td> <td></td> <td></td> <td></td> <td></td> </tr> <tr> <td>APPD</td> <td></td> <td></td> <td></td> <td></td> </tr> </table> </td> <td colspan="3">           FIGURE 22. 100 PASSENGER CRUISE POWER CURVE.         </td> <td>AE 790</td> </tr> <tr> <td colspan="4">           ROSKAM AVIATION AND ENGINEERING CORPORATION         </td> <td>           PAGE 34         </td> </tr> </table> </td> </tr> </table>	<table border="1"> <tr> <td> <table border="1"> <tr> <td>CALC</td> <td>G. SWIFT</td> <td>4-29</td> <td>REVISED</td> <td>DATE</td> </tr> <tr> <td>CHECK</td> <td></td> <td></td> <td></td> <td></td> </tr> <tr> <td>APPD</td> <td></td> <td></td> <td></td> <td></td> </tr> <tr> <td>APPD</td> <td></td> <td></td> <td></td> <td></td> </tr> </table> </td> <td colspan="3">           FIGURE 22. 100 PASSENGER CRUISE POWER CURVE.         </td> <td>AE 790</td> </tr> <tr> <td colspan="4">           ROSKAM AVIATION AND ENGINEERING CORPORATION         </td> <td>           PAGE 34         </td> </tr> </table>	<table border="1"> <tr> <td>CALC</td> <td>G. SWIFT</td> <td>4-29</td> <td>REVISED</td> <td>DATE</td> </tr> <tr> <td>CHECK</td> <td></td> <td></td> <td></td> <td></td> </tr> <tr> <td>APPD</td> <td></td> <td></td> <td></td> <td></td> </tr> <tr> <td>APPD</td> <td></td> <td></td> <td></td> <td></td> </tr> </table>	CALC	G. SWIFT	4-29	REVISED	DATE	CHECK					APPD					APPD					FIGURE 22. 100 PASSENGER CRUISE POWER CURVE.			AE 790	ROSKAM AVIATION AND ENGINEERING CORPORATION				PAGE 34
<table border="1"> <tr> <td> <table border="1"> <tr> <td>CALC</td> <td>G. SWIFT</td> <td>4-29</td> <td>REVISED</td> <td>DATE</td> </tr> <tr> <td>CHECK</td> <td></td> <td></td> <td></td> <td></td> </tr> <tr> <td>APPD</td> <td></td> <td></td> <td></td> <td></td> </tr> <tr> <td>APPD</td> <td></td> <td></td> <td></td> <td></td> </tr> </table> </td> <td colspan="3">           FIGURE 22. 100 PASSENGER CRUISE POWER CURVE.         </td> <td>AE 790</td> </tr> <tr> <td colspan="4">           ROSKAM AVIATION AND ENGINEERING CORPORATION         </td> <td>           PAGE 34         </td> </tr> </table>	<table border="1"> <tr> <td>CALC</td> <td>G. SWIFT</td> <td>4-29</td> <td>REVISED</td> <td>DATE</td> </tr> <tr> <td>CHECK</td> <td></td> <td></td> <td></td> <td></td> </tr> <tr> <td>APPD</td> <td></td> <td></td> <td></td> <td></td> </tr> <tr> <td>APPD</td> <td></td> <td></td> <td></td> <td></td> </tr> </table>	CALC	G. SWIFT	4-29	REVISED	DATE	CHECK					APPD					APPD					FIGURE 22. 100 PASSENGER CRUISE POWER CURVE.			AE 790	ROSKAM AVIATION AND ENGINEERING CORPORATION				PAGE 34	
<table border="1"> <tr> <td>CALC</td> <td>G. SWIFT</td> <td>4-29</td> <td>REVISED</td> <td>DATE</td> </tr> <tr> <td>CHECK</td> <td></td> <td></td> <td></td> <td></td> </tr> <tr> <td>APPD</td> <td></td> <td></td> <td></td> <td></td> </tr> <tr> <td>APPD</td> <td></td> <td></td> <td></td> <td></td> </tr> </table>	CALC	G. SWIFT	4-29	REVISED	DATE	CHECK					APPD					APPD					FIGURE 22. 100 PASSENGER CRUISE POWER CURVE.			AE 790							
CALC	G. SWIFT	4-29	REVISED	DATE																											
CHECK																															
APPD																															
APPD																															
ROSKAM AVIATION AND ENGINEERING CORPORATION				PAGE 34																											

Table 14. Design Point Performances.

Altitude ft.	Mach	SFC lb/hp/hr	PREQ hp	PAV hp	R.O.C. fpm
-----					
25 Passenger Configuration (Derated 30%)					
0	0.2	0.411	3,347	6,058	3,138
10,000	0.4	0.390	1,526	5,580	4,693
30,000	0.7	0.361	3,382	4,232	984
36 Passenger Configuration (Derated 20%)					
0	0.2	0.411	3,711	7,037	3,053
10,000	0.4	0.390	1,985	6,482	4,128
30,000	0.7	0.361	4,293	4,917	573
50 Passenger Configuration					
0	0.2	0.411	4,598	8,604	3,064
10,000	0.4	0.390	2,131	7,926	4,433
30,000	0.7	0.361	4,413	6,013	1,224
75 Passenger Configuration					
0	0.2	0.411	9,101	17,223	3,753
10,000	0.4	0.390	3,395	15,867	5,763
30,000	0.7	0.361	7,388	12,040	2,150
100 Passenger Configuration					
0	0.2	0.411	10,563	17,223	2,584
10,000	0.4	0.390	3,796	15,867	4,684
30,000	0.7	0.361	8,000	12,040	1,568



Symbol Chart for Tables 15 through 19.

<u>Symbol</u>	<u>Definition</u>
shp	Shaft horsepower
Nt	Number of fuel tanks
Ne	Number of engines
WF	Weight of fuel
Kfsp	Specific fuel weight, lbs/gal
Kosc	Oil system constant
Lnac	Length of engine nacelle, ft
GR	Gearing ratio
Dprop	Diameter of propfan, ft
We	Engine weight, lbs
Wgb	Gearbox weight, lbs
Wn	Nacelle weight, lbs
Wprop	Propeller weight, lbs
Wfs	Fuel system weight, lbs
Wosc	Oil system weight, lbs

Table 15. 25 Passenger Engine Installation Weights.

Data:	shp:	5,500.00	Ne:	2.00
	Nt:	2.00	WF:	3,767.00
	Kfsp:	5.87	GR:	8.99
	Kosc:	0.07	Dprop:	10.00
	Lnac:	17.83		

We:	805.40		
Wgb:	265.58		
Wn:	744.62	Wpwr:	5,856.53
Wprop:	845.00		
Wfs:	422.58		
Wosc:	112.76		

Table 16. 36 Passenger Engine Installation Weights.

Data:	shp:	5,500.00	Ne:	2.00
	Nt:	2.00	WF:	5,620.00
	Kfsp:	5.87	GR:	8.99
	Kosc:	0.07	Dprop:	10.00
	Lnac:	17.83		

We:	805.40		
Wgb:	265.58		
Wn:	744.62	Wpwr:	5,882.55
Wprop:	845.00		
Wfs:	448.60		
Wosc:	112.76		

Table 17. 50 Passenger Engine Installation Weights.

Data:	shp:	5,500.00	Ne:	2.00
	Nt:	2.00	WF:	6,939.00
	Kfsp:	5.87	GR:	8.99
	Kosc:	0.07	Dprop:	10.00
	Lnac:	17.83		

We:	805.40		
Wgb:	265.58		
Wn:	744.62	Wpwr:	5.897.72
Wprop:	845.00		
Wfs:	463.77		
Wosc:	112.76		

Table 18. 75 Passenger Engine Installation Weights.

Data:	shp:	11,000.00	Ne:	2.00
	Nt:	3.00	WF:	11,240.00
	Kfsp:	5.87	GR:	8.99
	Kosc:	0.07	Dprop:	14.33
	Lnac:	23.33		

We:	1,622.01		
Wgb:	751.16		
Wn:	1,396.18	Wpwr:	12,837.60
Wprop:	2,215.00		
Wfs:	641.81		
Wosc:	227.08		

Table 19. 100 Passenger Engine Installation Weights.

Data:	shp:	11,000.00	Ne:	2.00
	Nt:	3.00	WF:	13,878.00
	Kfsp:	5.87	GR:	8.99
	Kosc:	0.07	Dprop:	14.33
	Lnac:	23.33		
We:	1,622.01			
Wgb:	751.16			
Wn:	1,396.18	Wpwr:	12,861.01	
Wprop:	2,215.00			
Wfs:	665.22			
Wosc:	227.08			

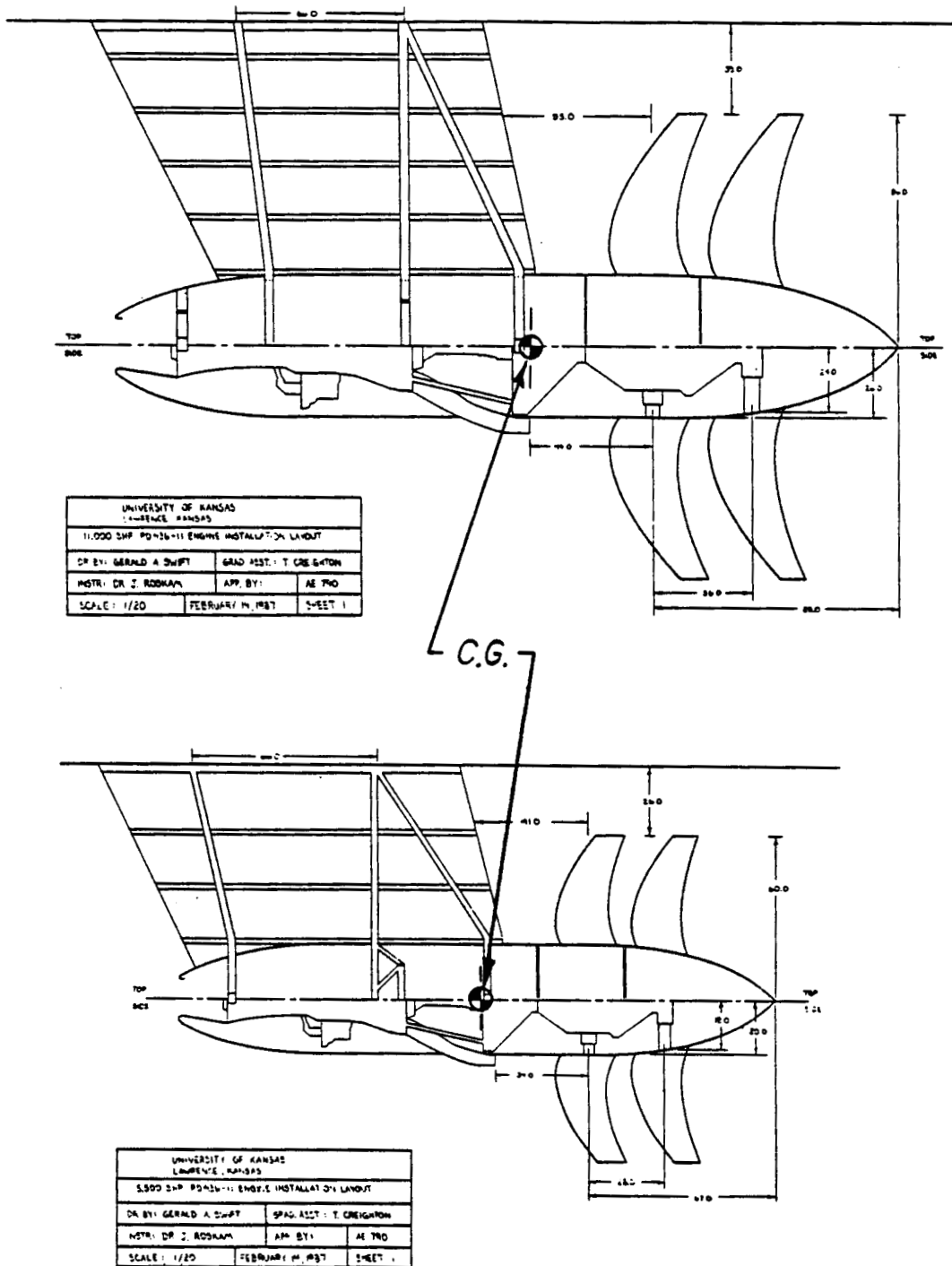

ORIGINAL PAGE IS  
OF POOR QUALITY

Figure 23. Propulsion Systems Centers of Gravity.

Table 20. Propulsion System Costs Summary.

Propeller Cost Estimation (NASA CR-165499)

5,500 shp derivative: \$339,781 per engine  
11,000 shp derivative: \$667,590 per engine

Engine Cost Estimation (NASA CR-168115)

5,500 shp PD436-11 derivative: \$1,183,241 per engine  
11,000 shp PD436-11 derivative: \$2,060,143 per engine

\*\* For a detailed cost breakdown, see Reference 4 \*\*

## 5. Integration and Commonality

Aft mounted engines were the best way to achieve commonality throughout the family of commuters. This choice was made not from an engine point of view, but from a configuration and handling qualities perspective. For each aircraft, the tailcones, empennage, and wing torque boxes are the same. Therefore, engine placement and numbers had to be the same throughout the family. The twin body configurations still use the same pylon-fuselage mounts as all single body configurations. Consequently, the tail cone frames will need to be sized to support the 11,000 shp engines and subsequent loading. Figure 24 illustrates the general layout of the family.

Figures 27 and 28 show the 5,500 shp and 11,000 shp engine installation layouts. The fuselage-eylon attachment points are 66 inches apart throughout due to the tailcone frame spacing of 22 inches. The layouts vary slightly due to:

(1) the engine attachment points are at different spacings for the two engines,

(2) the fuselage-to-blade tip clearance for both layouts is 0.20 times the fan diameter. This ratio is dependent on both acoustic and stability constraints.

Figures 27 and 28 show the conceptual frames for the two engines. These frames will facilitate both engine removability and accessibility.

Additional restraints have been made on the design due to the propfan installation. They are as follows:

1. Redundant empennage control cables had to be routed along separate lines to protect against loss of control due to blade penetration.
2. The cabin aft pressure bulkhead is located forward of the blades' plane of rotation to prevent the possibility of rupture due to blade separation.
3. Additional structure (and weight) has been added to the tailcone and empennage surfaces to protect against sonic fatigue and to enhance noise reduction in the passenger cabin. This topic will be discussed in more detail in the following chapter.

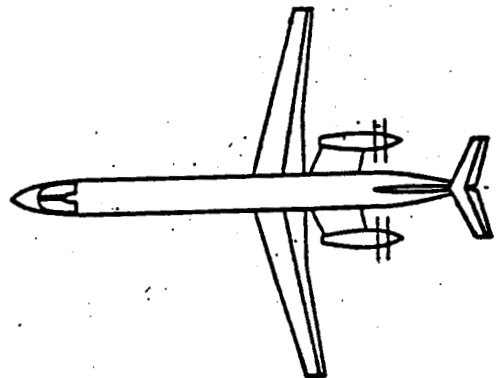
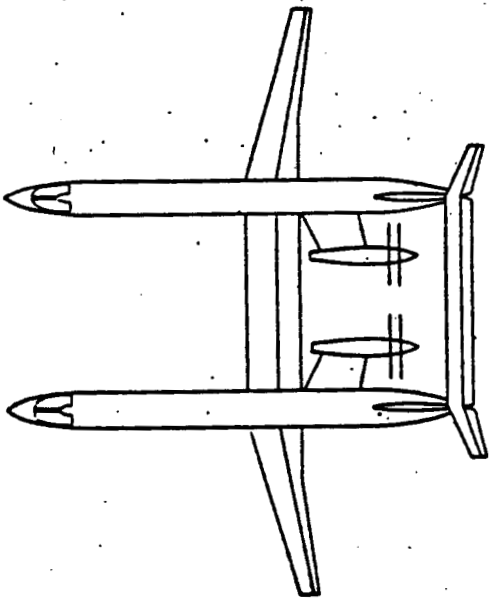
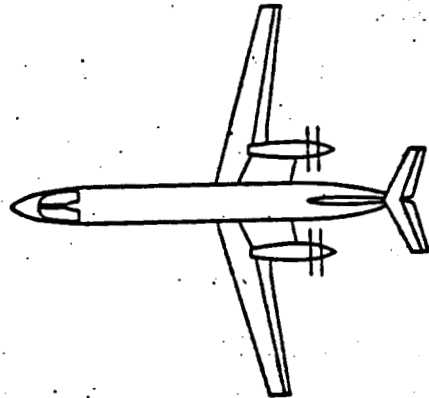
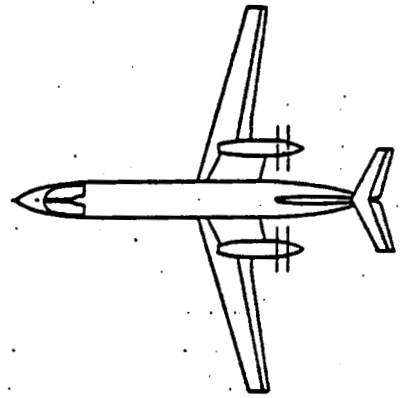
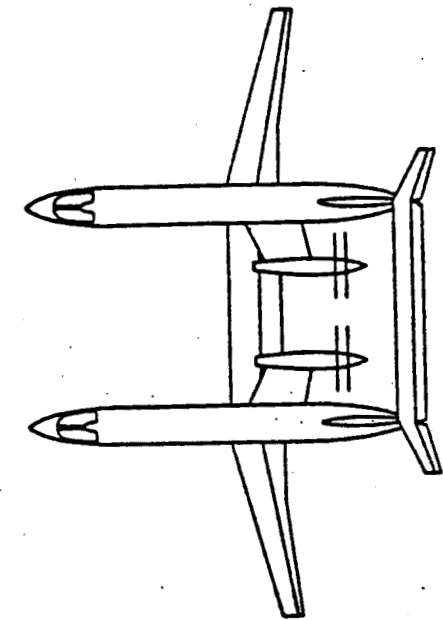
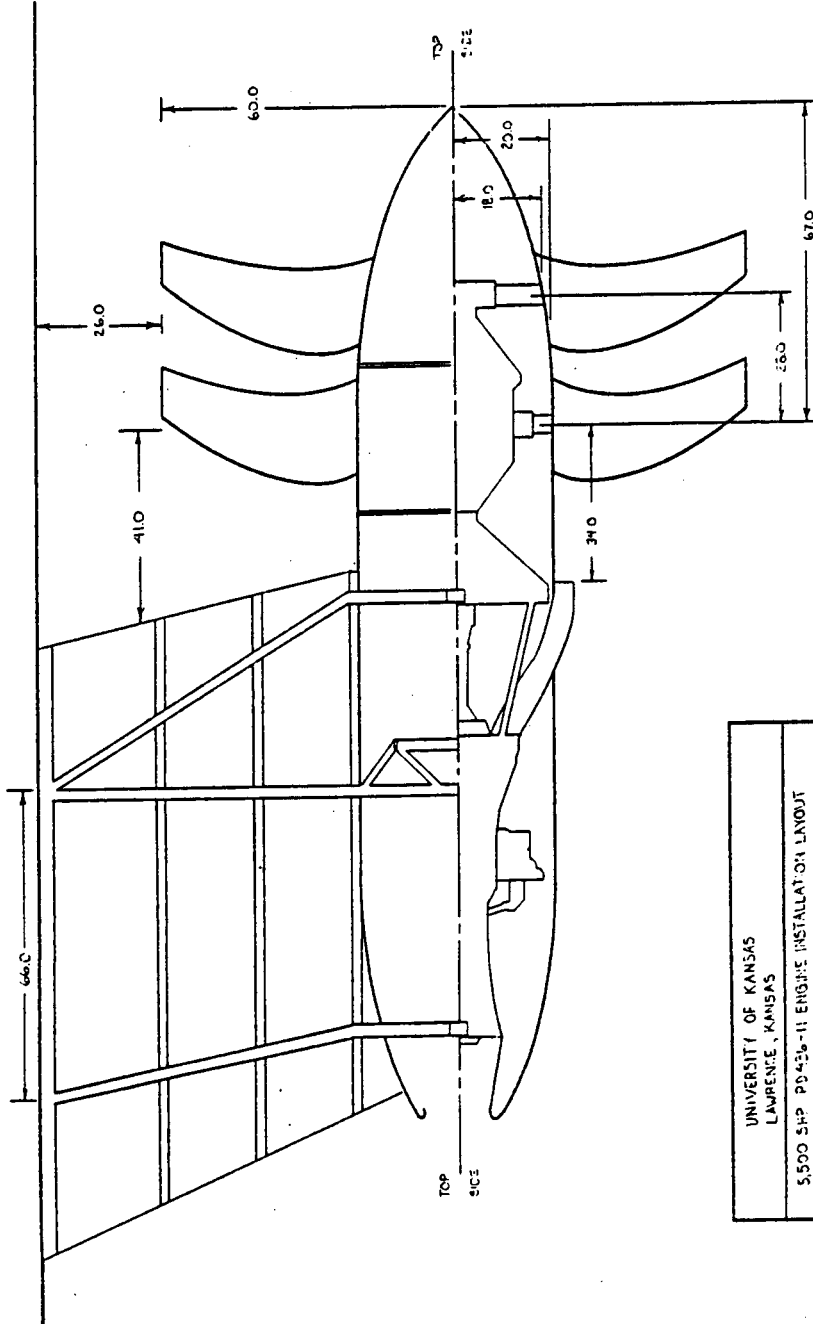

Figure 24. Overview of Propulsion System Layout.



ORIGINAL PAGE IS  
OF POOR QUALITY



UNIVERSITY OF KANSAS LAWRENCE, KANSAS			
5,500 SHP PD-426-11 ENGINE INSTALLATION LAYOUT			
DR BY: GERALD A. SWIFT	GRAD. ASST.: I. CREIGHTON		
INSTR: DR. J. ROSKAM	APP. BY:	AE 790	
SCALE: 1/20	FEBRUARY 14, 1957		SHEET 1

Figure 25. 5,500 shp Engine Installation.

ORIGINAL PAGE IS  
OF POOR QUALITY

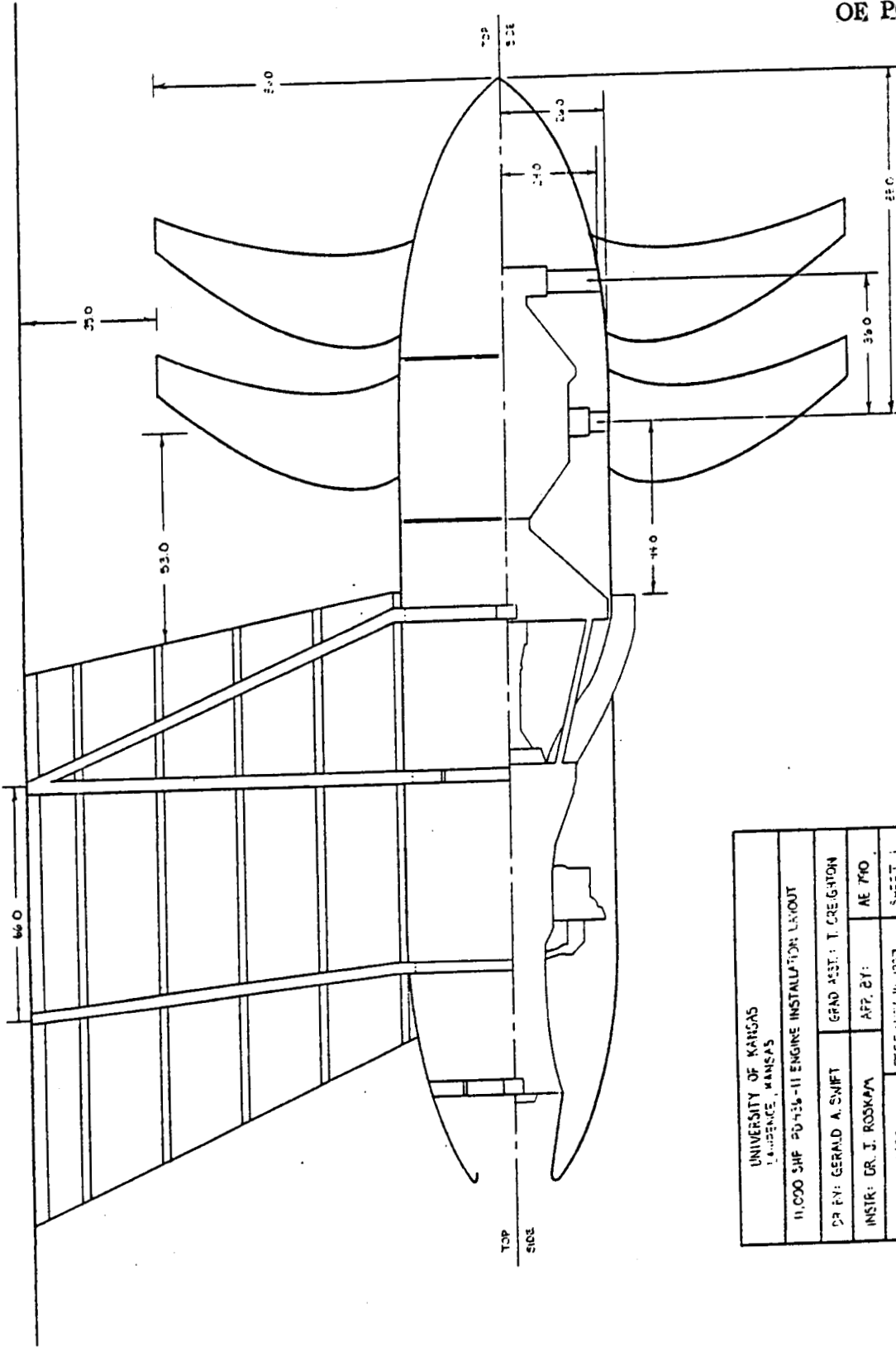

UNIVERSITY OF KANSAS LAWRENCE, KANSAS	
11,000 SHP P-51B-11 ENGINE INSTALLATION LAYOUT	
DR BY: GERALD A. SNIFF	GRAD ASST: T. CREIGHTON
INSTR: DR. J. ROSKOPF	APP. BY: AE 710
SCALE: 1/20	REVISION: 10, 1957 SHEET 1

Figure 26. 11,000 shp Engine Installation.

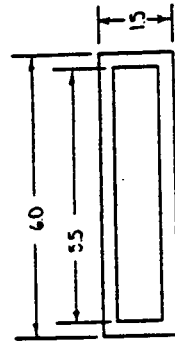
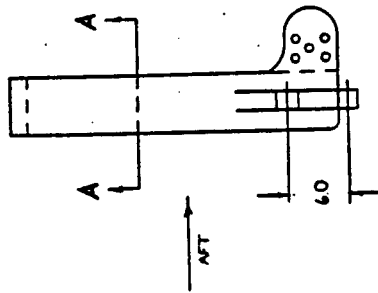
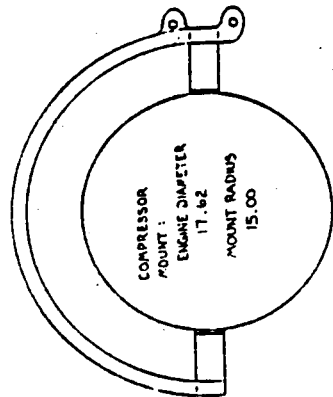
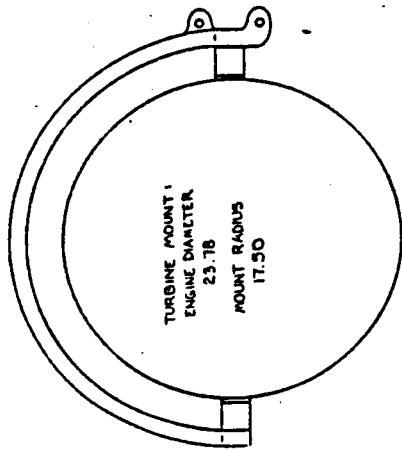
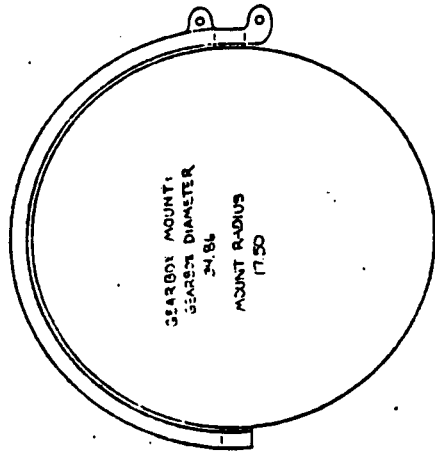

SECTION A-A

UNIVERSITY OF KANSAS LAWRENCE, KANSAS		
5,500 SHP ENGINE MOUNT		
DESIGNED BY: GERALD A. SWIFT	DATE: 12 7 37	
5 MARCH 1937	SCALE: 1:10	75.

Figure 27. 5,500 shp Engine Frames.

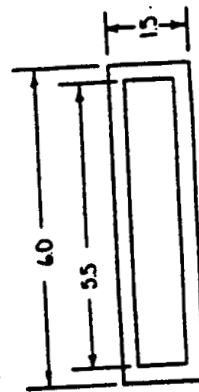
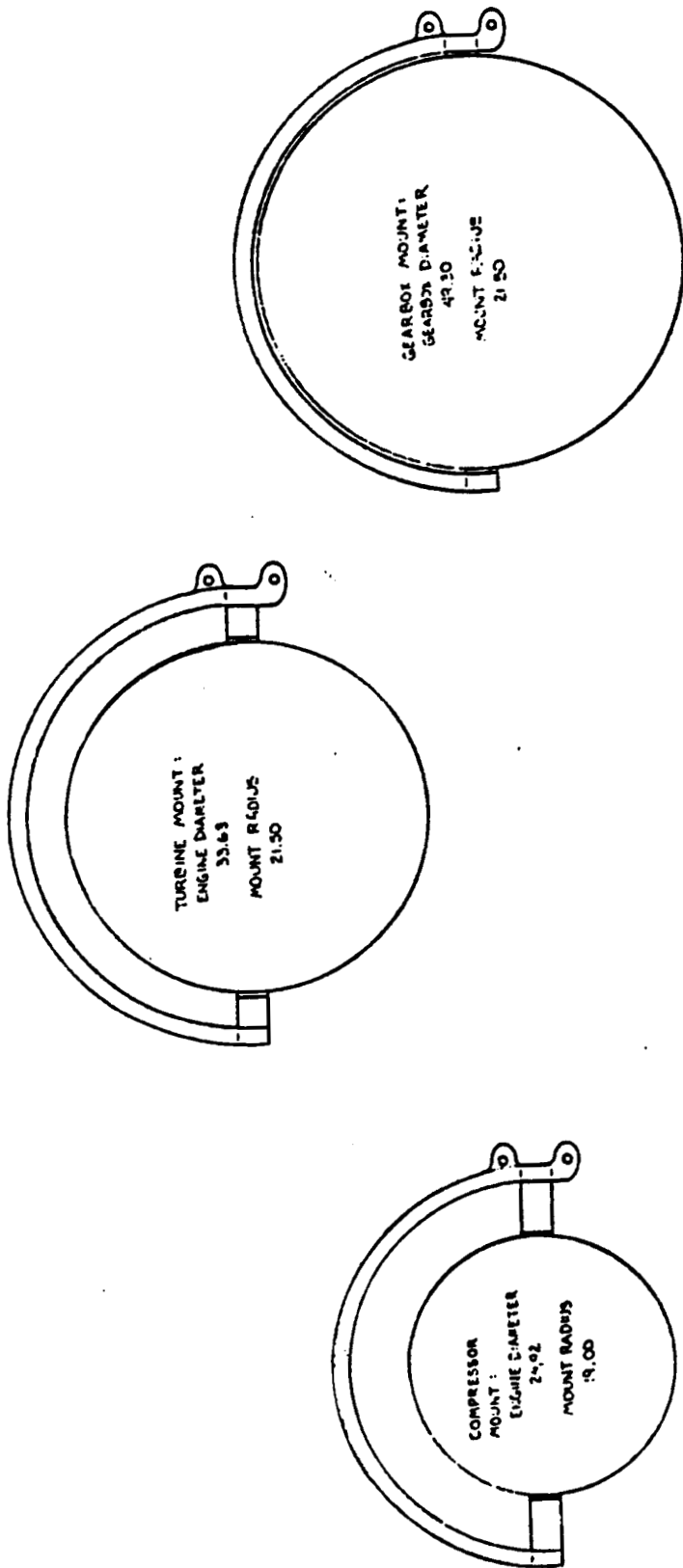

SECTION A-A

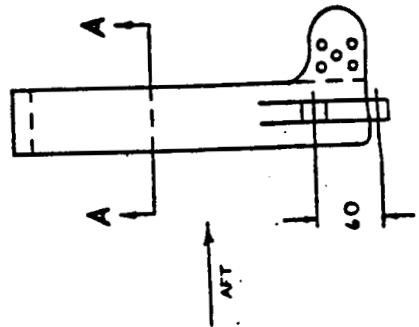

ORIGINAL PAGE IS  
OF POOR QUALITY

UNIVERSITY OF KANSAS LAWRENCE, KANSAS		
11,000 SHP ENGINE MOUNT		
DR. BY: GERALD A SWIFT	AE 1790	
5 MARCH 1967	SCALE: 1:10	PG.

Figure 28. 11,000 shp Engine Frames.

## 6. Noise

The major disadvantage of counter-rotation propfans over advanced turboprops is in the area of noise. This chapter addresses counter-rotation noise sources, characteristics, and methods for reduction.

### 6.1. Sources

Counter-rotation propfans have several mechanisms from which noise is generated. Figure 29 provides a general overview. During low speeds at high power settings such as at take-off and climb, the high blade loadings are the chief contributor to noise. The propeller wake and vortices generated by the upstream propeller interact with the downstream propeller causing fluctuations in loading and generating higher noise levels. Figure 30 illustrates this. Also, high angles of attack cause uneven blade loadings on the propfan plane. During cruise the blade loading is reduced but tip Mach numbers are greatly increased. Propfan tip speeds may reach as high as Mach 1.1 to 1.2 (Reference 10) and the abrupt pressure differences caused by the shock waves create high noise levels. The propfan is relatively quiet during descent when blade loading and tip speeds are low.

Other sources of propfan noise include basically installation effects:

- \* non-uniform flow from fuselage or engine nacelle boundary layer separation,
- \* slipstream turbulence from the engine pylon or from the wings at high angles of attack,
- \* exhaust flow passing through the propeller hubs.

### 6.2. Noise Characteristics

Counter-rotation noise levels are typically 15 to 20 db higher than single rotation levels. Even more, counter-rotation directivity patterns show higher noise levels over a wider area. Figure 31 illustrates this. Consequently, a larger section of the fuselage both fore and aft of the propfan plane are exposed to higher noise levels with counter-rotation propellers.

It was mentioned that during low speed operation, angle of attack effects propfan noise levels. Figure 32 shows the significance of this. Although this figure is for single rotation, the trends for counter-rotation will be similar. Therefore, for a 10 degree increase in angle of attack, a 5 to 7 db increase in noise in the plane of rotation can be expected. This may increase in front of the propeller plane.

# Noise Source Mechanisms

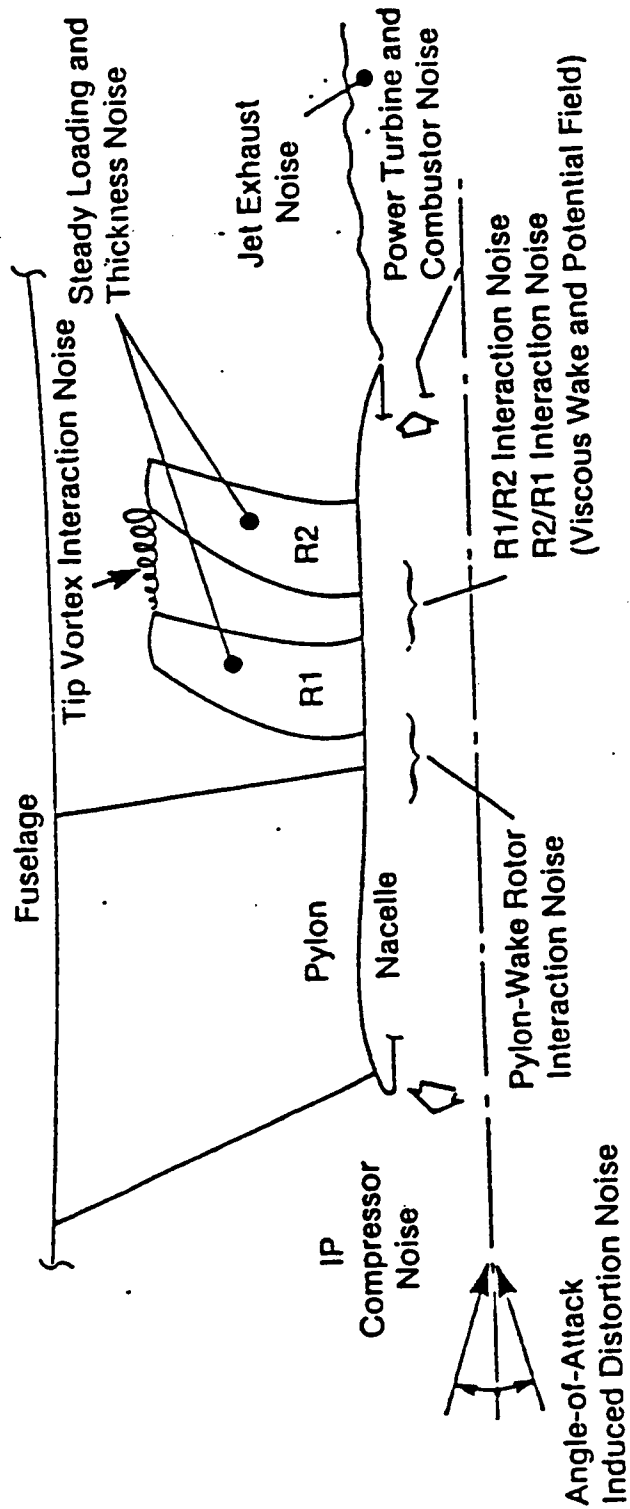
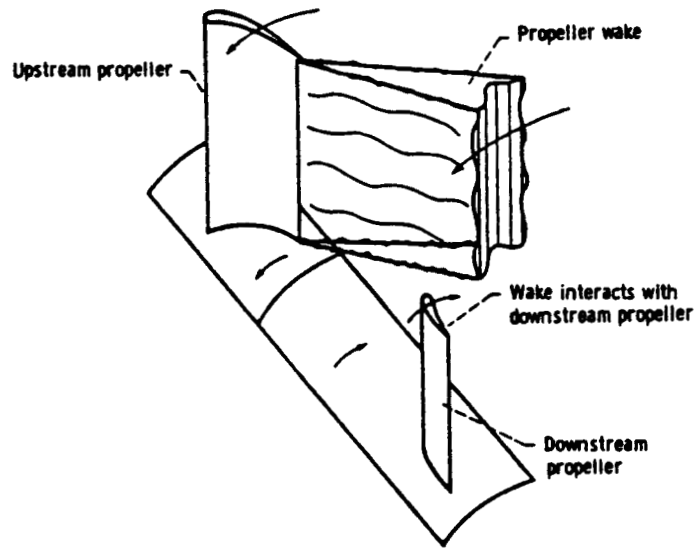
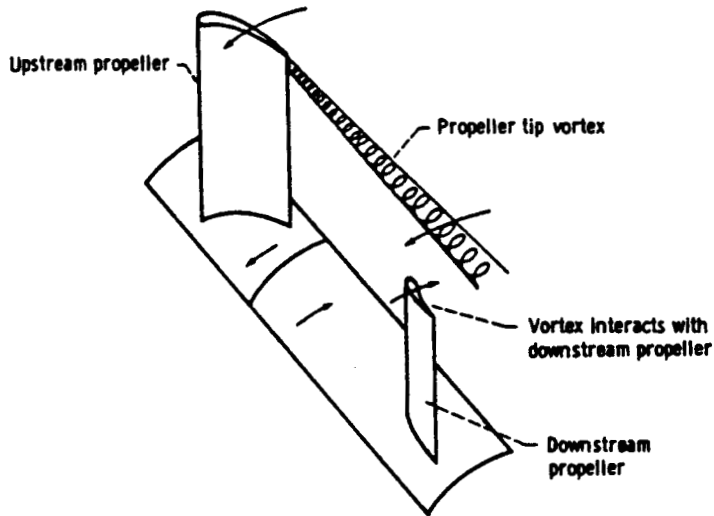

Figure 29. General Overview of Propfan Noise Generating Mechanisms.



(a) Wake interaction.



(b) Vortex interaction.

Figure 30. Propfan Noise Sources due to Blade Interaction.  
(NASA TM-87099)

At cruise a 155 to 160 db noise level can be expected on the fuselage surface in the propeller plane. This is shown in Figure 33. These high noise levels can be expected to remain as far as 30 degrees in front and 20 degrees aft of the propeller plane. Therefore, the tailcone for the family of commuters will have to be designed radically different than the fuselage sections due to acoustic impingement effects.

### 6.3. Cabin Noise Reduction

The aft pressure bulkheads throughout the entire family are located at the aft pylon mount as shown in Figure 34. This location is just over 40 degrees in front of the propeller plane of rotation. From Figure 33, airborne noise drops below 145 db at this location. Therefore, the aft mount design has an advantage in cabin noise reduction due to engine placement.

The tailcone section will have to be structurally designed to withstand the high level, long duration acoustic fatigue levels. Reference 10 stated that the MD-80 is typically exposed to 120 db for 2,000 hours over its nominal 75,000-hour lifetime; however, the MD-91X (proposed counter-rotation version) may be exposed to 150 db for 50,000 hours. This indicates large structural weight penalties. Table 21 gives the proposed acoustic weight penalties for the 5,500 shp and 11,000 shp engines based on methods given in Reference 8. However, McDonnell Douglas claims that current technology may reduce the figures given in Table 21 by 75 percent (AWST April 13, 1987).

Table 21. Acoustic Weight Penalties.

Noise Level on Tailcone in Propfan Plane:	155 db
Clearance Between Propeller and Fuselage:	0.20 Fan Diameter
5,500 shp Acoustic Weight Penalty:	2,200 lbs/airplane
11,000 shp Acoustic Weight Penalty:	5,200 lbs/airplane

To understand the methods used to reduce cabin noise, the paths along which noise enters the cabin must be examined. Figure 35 illustrates these paths. They are:

- (1) from the propfan through the air to the tailcone and along the structure into the cabin,
- (2) from mechanical vibration through the engine pylon into the fuselage,
- (3) from the propellers through the air directly to the cabin skin.



# Comparison of OASPL-Directivity of Single and Counterrotating Rotors

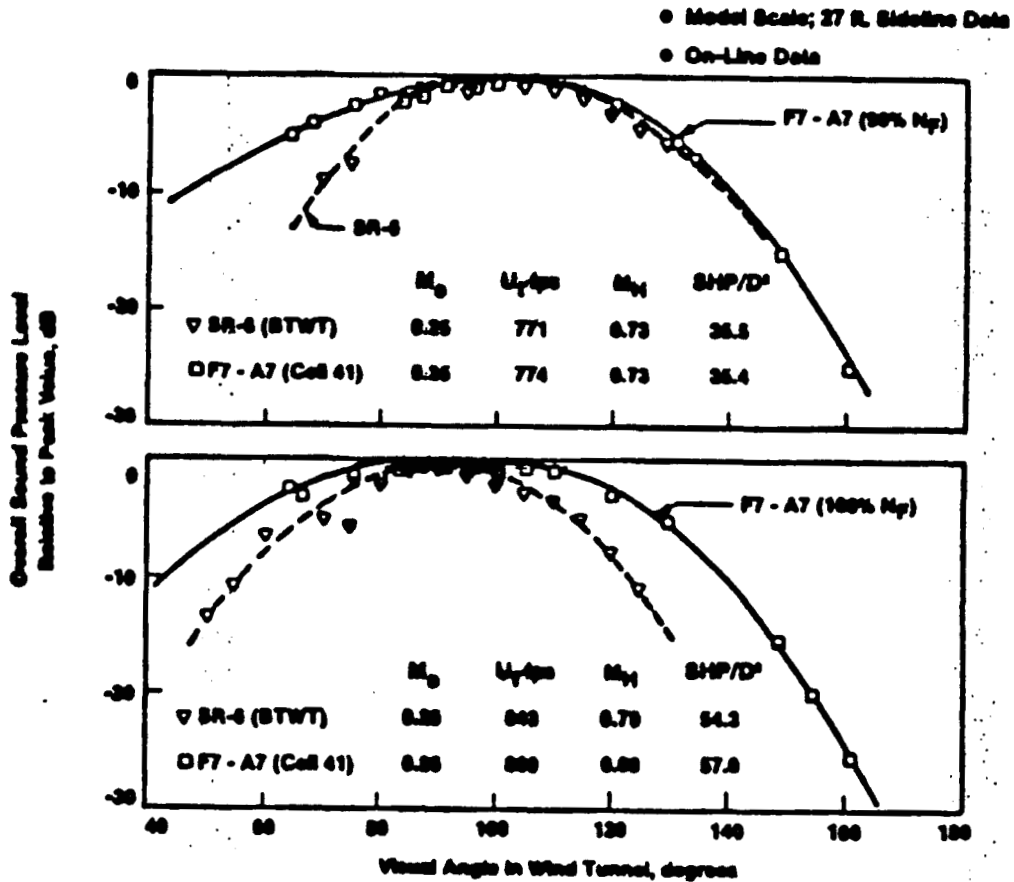

Figure 31. Comparison of Single and Counter-Rotation Directivity Patterns.

# EFFECT OF ANGLE OF ATTACK ON FLYOVER NOISE

SR-7A, 9 X 15

BASELINE CONFIGURATION -- NO WING  
 BLADE FUNDAMENTAL TONE  
 TAKEOFF BLADE ANGLE (37.8 DEG.)  
 800 FT./SEC TIP SPEED  
 0.2 TUNNEL MACH

ORIGINAL PAGE IS  
 OF POOR QUALITY

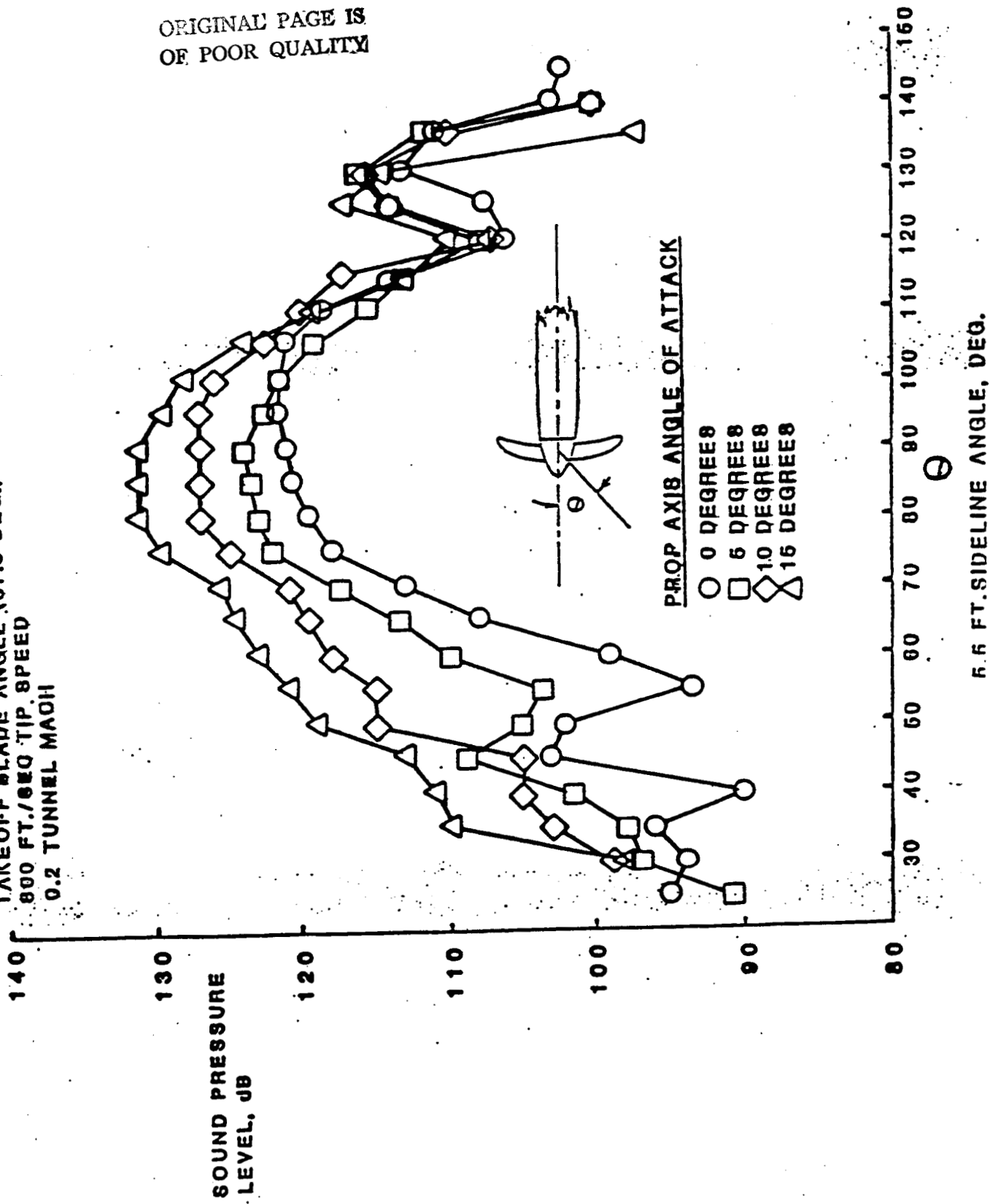

Figure 32. Effect of Angle of Attack on Flyover Noise for a Single Rotation Configuration. (Compliments of NASA-Lewis)

CR NOISE DIRECTIVITY AT M=.72 CRUISE

100% SPEED, 0.3 DIA. SIDELINE

8x6 WIND TUNNEL

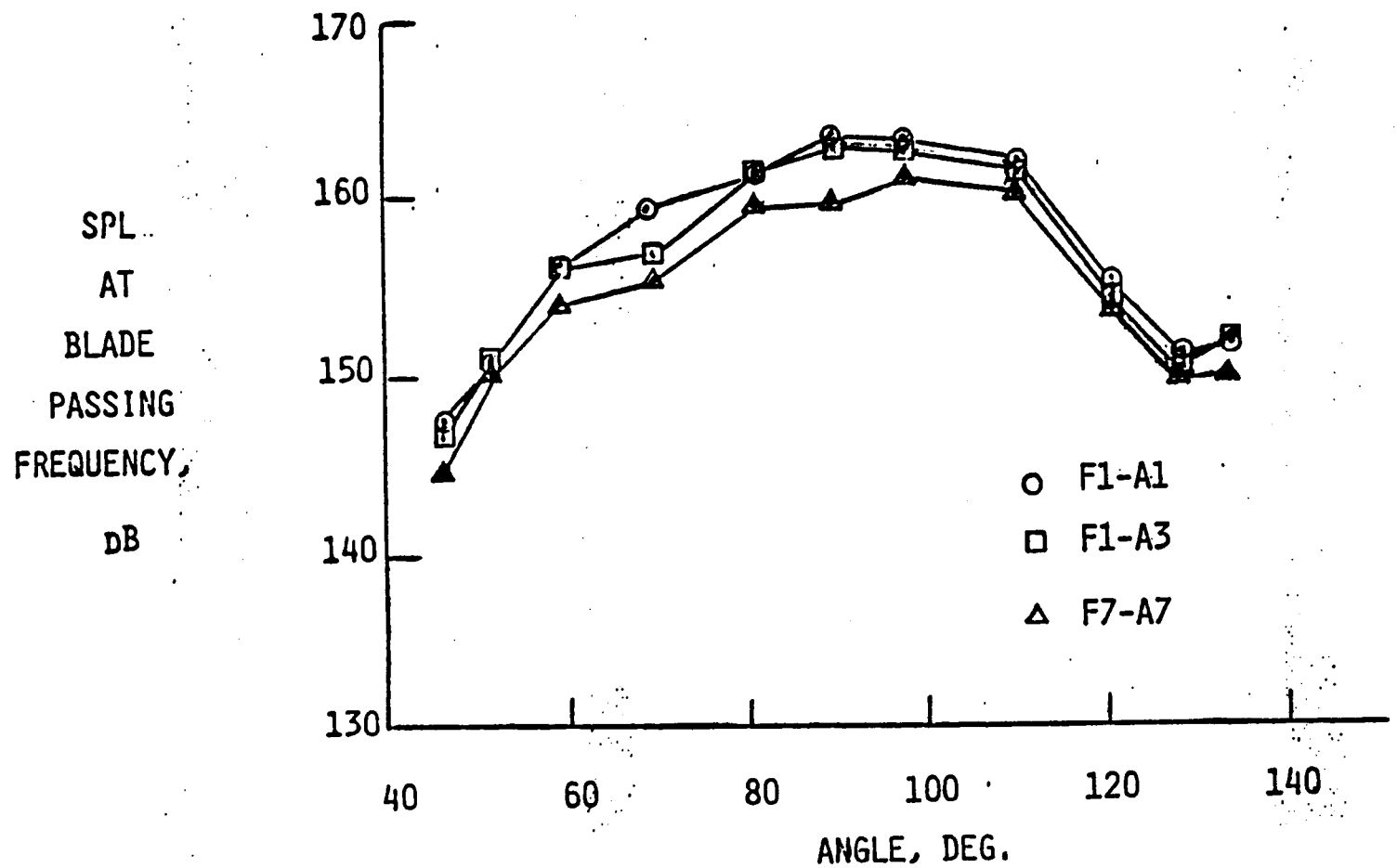

Figure 33. Counter-Rotation Cruise Noise Levels. (Compliments of NASA-Lewis)

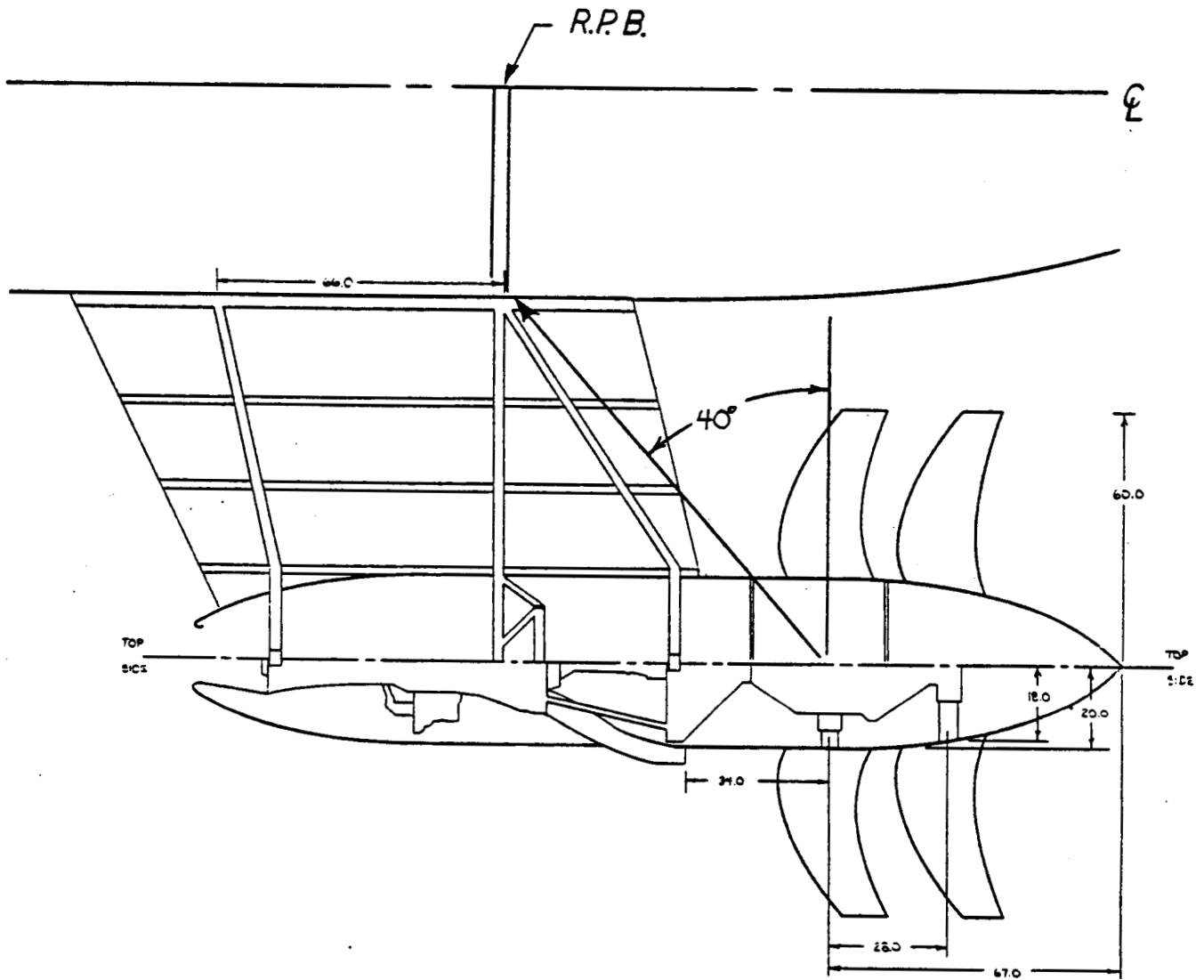

Figure 34. Aft Pressure Bulkhead Location for the Family of Commuters.

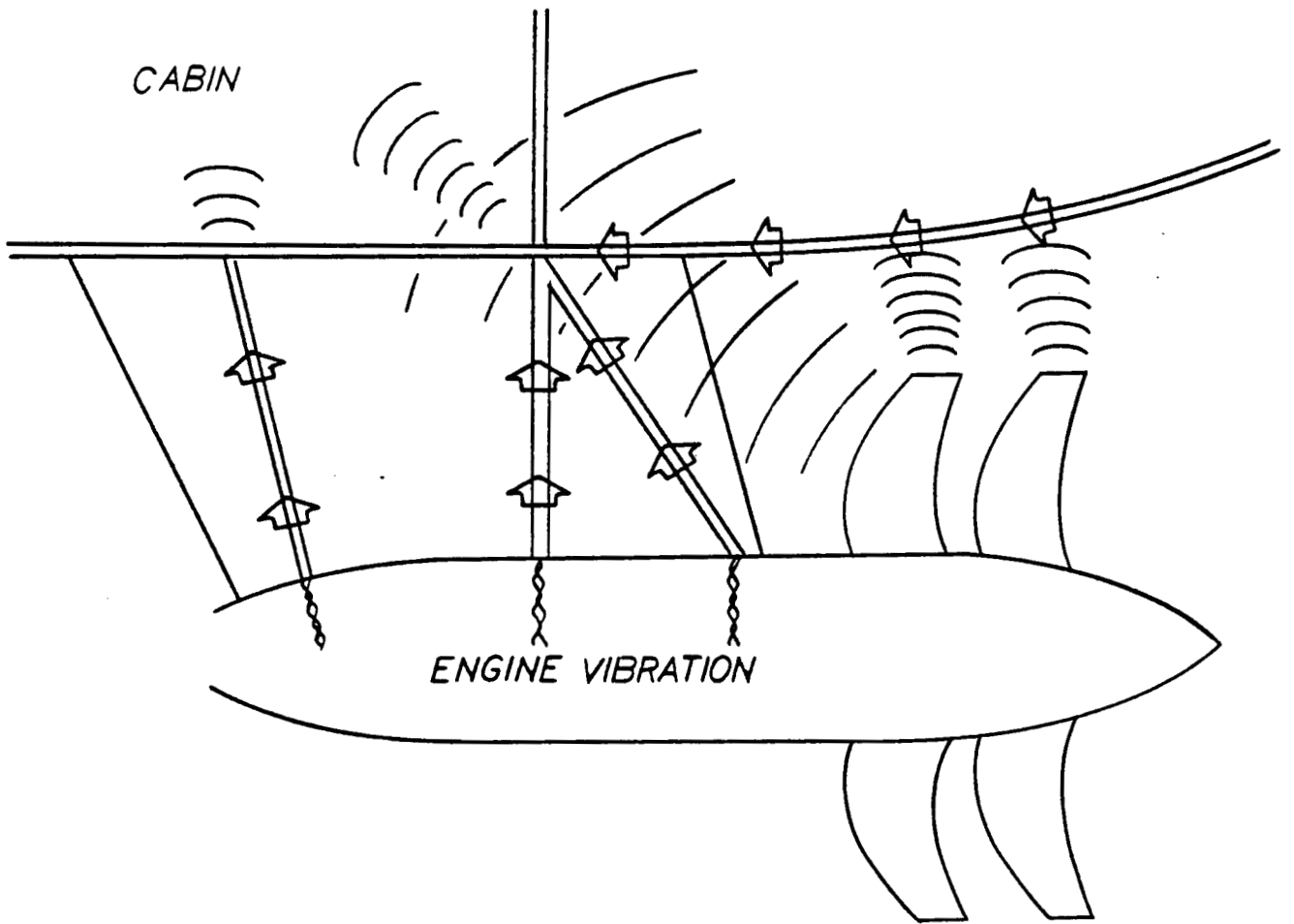

Figure 35. Transmission Paths of Cabin Noise.

There are several methods proposed that are currently being studied to reduce cabin interior noise.

1. Double wall fuselage design is the method traditionally proposed. Figure 36 is an illustration.
2. Rubber backed adhesive metal foil lining is currently being studied by McDonnell Douglas to damp out high frequencies.
3. Tuned vibration absorbing weights located in the fuselage or engine structure may reduce noise. For example, the DC-9 used tuned mechanical absorbers in the engine mounts to reduce noise to acceptable levels.

Acoustic weight treatment does have its limitations. Figure 38 shows this conceptually. There comes some point during the addition of acoustic weight treatment when the added noise reduction is not effective compared to the increase in weight. This is due to structural borne noise.

Environmental noise levels are currently being analyzed in flight testing. One of the purposes of the current NASA Propfan Test Assessment (PTA) and GE UDF demonstrator aircraft is to prove that the advanced propulsion systems will meet FAR 36 noise limitations. There are methods that can be used to reduce airborne noise. They are:

- (1) reduce blade loading by increasing fan diameter.
- (2) reduce diameter of the second blade row in the counter rotation configuration. As shown in Figure 39, this would take the blades out of the vortex flow of the upstream propellers.
- (3) move the exhaust from in front of the propfan plane of rotation. Hub exhaust considerations have been examined.

The May 1987 issue of Aerospace America stated that "Flight testing of the General Electric's advanced fan propulsion system confirmed that results of model tests agree with full scale results. Wind tunnel data show that the unducted fan performs better than federal noise regulations require." Therefore, it has been assumed that the noise requirements for the K.U. Family of Commuters will meet FAR 36 requirements.

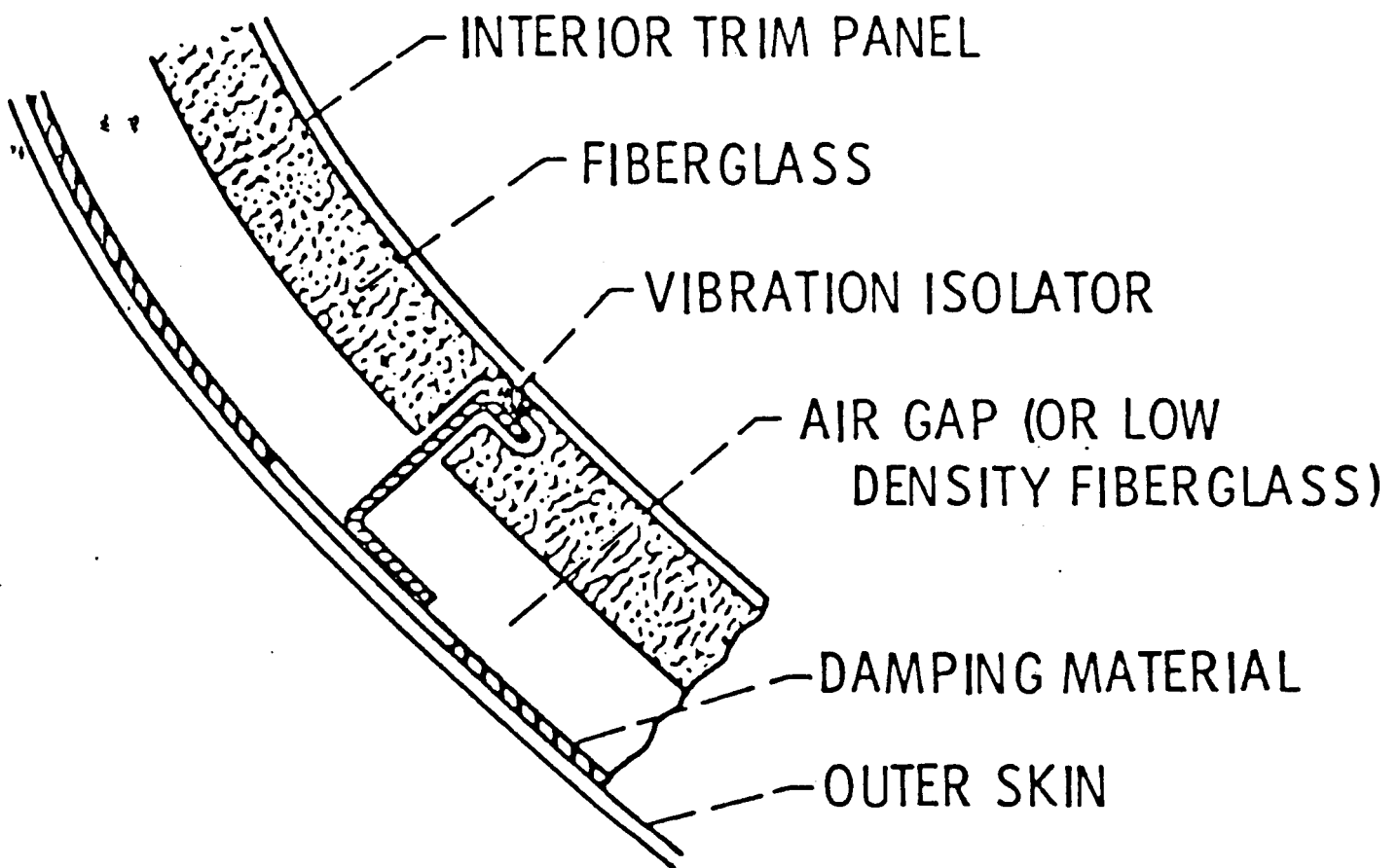

DOUBLE WALL CONCEPT USES OPTIMUM COMBINATION OF MASS, DENSITY, STIFFNESS, AND DAMPING

Figure 36. Double Wall Fuselage Design Concept. (Compliments of NASA-Lewis)

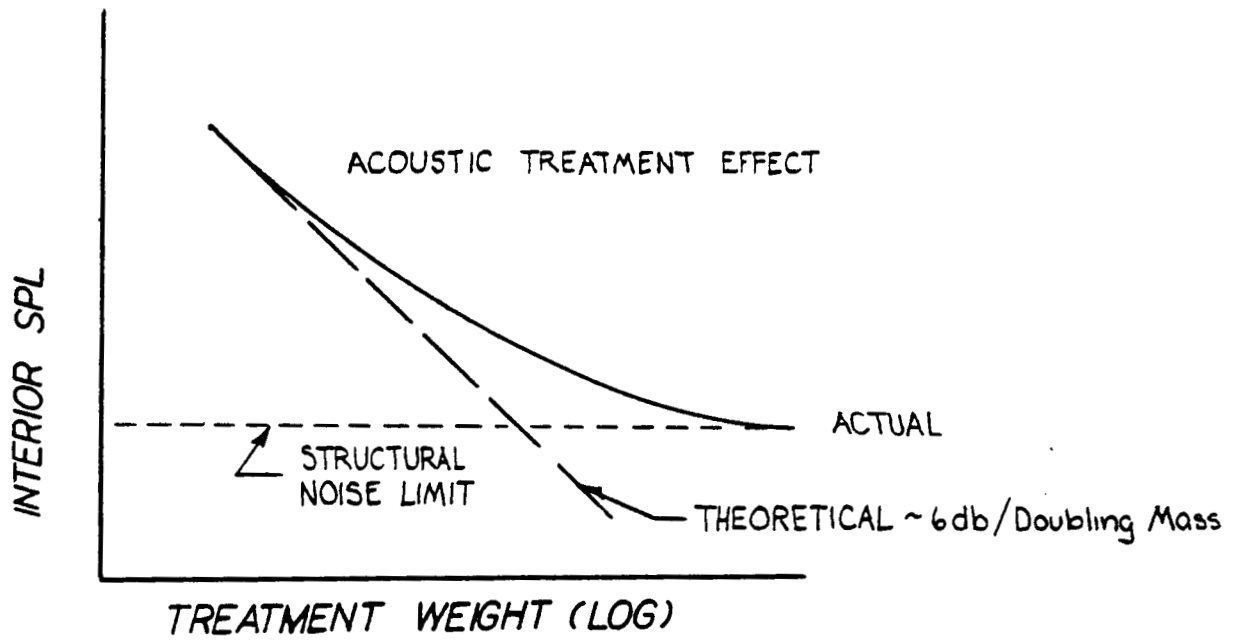

Figure 37. Acoustic Weight Treatment Effectiveness.

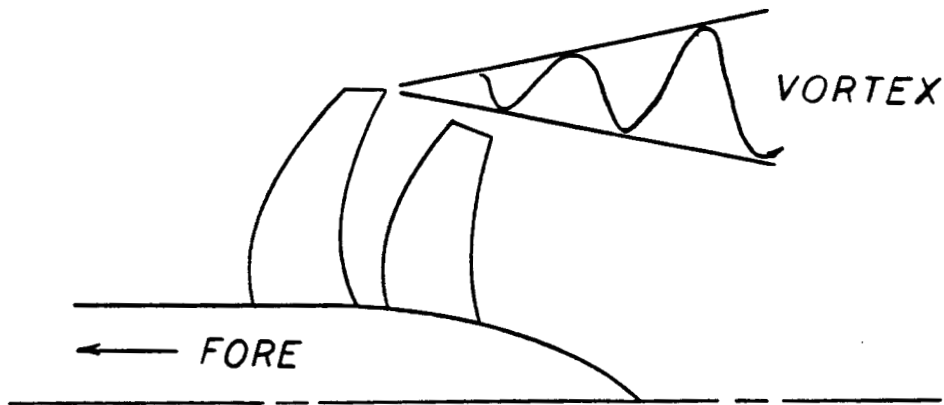

Figure 38. Downstream Bladerow Diameter Reduction.



## 7. Conclusions and Recommendations

### 7.1. Conclusions

1. Two engine cores, both derivatives of the APET PD436-11 designs, were needed for the family of commuters: a 5,500 shp core for the 25, 36, and 50 passenger configurations and an 11,000 shp core for the 75 and 100 passenger configurations.
2. Counter-rotating propfans were chosen for propulsion. The counter-rotation propfan for the 5,500 shp core has a diameter of 120 inches; the counter-rotation propfan for the 11,000 shp core has a diameter of 172 inches.
3. The 25 and 36 passenger engine cores have been derated 30 and 20 percent respectively due to stability and performance considerations. This will increase the service life of these engine cores.
4. From preliminary results of current unducted fan demonstrator flight testing, it is predicted that propfans will meet and possibly exceed FAR 36 noise requirements. Cabin interior noise levels are yet to be determined.
5. The MD91-X Demonstrator Airplane is basically the proof of concept for the K.U. proposal. The MD91-X has similar configuration and engine integration as the K.U. design. Flight testing is scheduled to begin later this year.
6. Aft mounted propfans allowed the family of commuters to achieve a high degree of commonality especially in wing torque box, fuselage tailcone, and control system designs.

### 7.2. Recommendations

1. Inlet and nozzle designs were sized using preliminary methods. More detail is needed in this area. A hub exhaust concept should also be studied.
2. The gearbox design can be enhanced with recent technology. Since the K.U. design began in August of 1986, great strides have been made in this area and will continue with the proposed demonstrator engines.
3. Currently, there is no clear-cut methodology for predicting propfan noise. With the current demonstrator airplanes, data will be available for numerical acoustical analysis of the proposed propfan design.
4. Acoustic treatment weight can be reduced with new technology. McDonnell Douglas has proposed 75% weight reductions over methods proposed four years ago.

## 8. References

1. University of Kansas AE 790 Design Team; Class I Designs of a Family of Commuter Airplanes; University of Kansas, 1986.
2. Morgan, L.K., University of Kansas AE 790 Design Team; A Cost Analysis for the Implementation of Commonality in the Family of Commuter Airplanes; University of Kansas, April, 1987.
3. University of Kansas AE 790 Design Team; A Class II Weight Assessment for the Implementation of Commonality an Preliminary Structural Designs for the Family of Commuter Airplanes; University of Kansas, 1987.
4. University of Kansas AE 790 Design Team; Class II Design Update for the Family of Commuter Airplanes; University of Kansas, 1987.
5. Russell, M., and Haddad, R., University of Kansas AE 790 Design Team; Presentation of Structural Component Designs for the Family of Commuter Airplanes; University of Kansas, 1987.
6. Hensley, D., University of Kansas AE 790 Design Team; Flight Control Design and Handling Quality Commonality by Seperate Surface Stability Augmentation for the Family of Commuter Airplanes; University of Kansas, 1987.
7. Anderson, R.D., Advanced Propfan Engine Technology (APET) Definition Study, Single and Counter-Rotation Gearbox/Pitch Change Mechanism, Allison Gas Turbine Division, July 1985. (NASA CR-168115)
8. Weisbrich, A.L., Godston, J., and Bradley, E., Technology and Benefits of Aircraft Counter Rotation Propellers, Hamilton Standard, Pratt and Whitney, Lockheed-Georgia, December 1982. (NASA CR-168258)
9. Roskam, J., Airplane Design Part VI: Preliminary Calculation of Aerodynamic, Thrust and Power Characteristics, Roskam Aviation and Engineering Corporation, Rt. 4, Box 274, Ottawa, Kansas 66067, 1985.
10. Aviation Week and Space Technology, April 13, 1987, pp. 52-93.
11. Dittmar, J.H., Some Design Philosophy for Reducing the Community Noise of Advanced Counter-Rotation Propellers, NASA-Lewis Research Center, Cleveland, Ohio, August 1985. (NASA TM-87099)