

NASA Technical Memorandum 100864

## Power Transmission Studies for Tethered SP-100

(NASA-TM-100864) POWER TRANSMISSION STUDIES  
FOR TETHERED SP-100 (NASA) 16 p CSCL 10B

N88-21251

Unclas  
G3/20 0140058

David J. Bents  
*Lewis Research Center*  
*Cleveland, Ohio*

Prepared for the  
23rd Intersociety Energy Conversion Engineering Conference  
cosponsored by the ASME, AIAA, ANS, SAE, IEEE, ASC, and AIChE  
Denver, Colorado, July 31—August 5, 1988

**NASA**

## POWER TRANSMISSION STUDIES FOR TETHERED SP-100

David J. Bents  
National Aeronautics and Space Administration  
Lewis Research Center  
Cleveland, Ohio 44135

### ABSTRACT

The tether/transmission line connecting the SP-100 to space station presents some unorthodox challenges in high-voltage engineering, power transmission, and distribution. Although it is believed that relatively straightforward application of terrestrial HV technology can answer most of these challenges there are several new issues, problems unique to this concept which require further study. The line, which doubles as a structural element of this unusual spacecraft, will convey HVDC from SP-100 to the platform in low-earth orbit, an environment where the local plasma is sufficient to cause breakdown of exposed conductors at potentials of only a few hundred volts. Its anticipated several years operation, and continuously accumulating exposure to meteoroids and debris, raises an increasing likelihood that mechanical damage, including perforation, will be sustained in service. The present concept employs an array of gas insulated solid wall aluminum coaxial tubes; a conceptual design which showed basic feasibility of the SP-100 powered space station. Practical considerations of launch, deployment and assembly have lead to investigation of reel-deployable, dielectric insulated coaxial cables, versus automated stacking/assembly for the tubes. To be competitive the dielectric would have to operate reliably in a radiation environment under electrical stresses exceeding 50 kV/cm. The SP-100/transmission line/platform high-voltage interfaces are also considered. Starting from the source (SP-100), whose power output is low voltage, a high-frequency inverter and its connections are used to simultaneously provide voltage boost, circuit switching, and fault protection.

### DISCUSSION

The SP-100 nuclear space power system can be used to provide power to a manned LEO platform such as space station when it is tethered high enough above the platform to reduce reactor attributable astronaut radiation dosage to low levels (1). In this installation method, SP-100 is tethered some 1 to 5 km above the platform, allowing an instrument-rated shield design to serve as a man-rated configuration for all locations near the

space station. The advantage of this method is that reactor shield mass is traded for separation distance, resulting in greatly reduced overall system mass for this installation. The resulting concept requires power to be transmitted from the power source to the manned platform over a distance of 1 to 5 km. Since the SP-100 employs thermoelectric conversion its output is 200 VDC, higher voltage than most of the platform loads but not high enough for reasonable transmission line mass. For reasonable conductor mass high-voltage transmission is necessary. Previous work (2,3) has shown that it is possible to connect the SP-100 to the platform with an array of coaxial tubes which serve as fully enclosed high-voltage conductors completely isolated from the space plasma environment. Although the SPEAR experiment (4,5) has shown that it may be possible to expose high voltages to that environment without breakdown, plasma behavior is actually dependent on local gradient - for example, in SPEAR, great care was taken in design of the spacecraft to ensure that the voltage gradients actually seen by the plasma were moderate, less than 400 v/cm. For the conductor sizes and cross-sections typically associated with economical HV power transmission, however, much higher gradients are present. The coaxial tube array also used high gradients (20 to 100 kV/cm) but avoids the space plasma exposure/interaction problem by employing the spacecraft hull as a Gaussian shell, with the jacket wall of each tube an extension of that surface.

By fully enclosing the high-voltage conductors within tubes, the plasma environment is removed from consideration but since perforation of a tube by meteoroid impact will cause the tube to fail, the meteoroid environment is not removed from consideration. Due to surface exposure along its length over prolonged periods of time the coaxial array will be subject to meteoroid strikes. In the design process, great care is taken with respect to array layout geometry, bumping and dimensions, and number of redundant tubes so that a particle large enough to cause perforation has low probability of impact, and that, in the event of tube perforation, there will remain a sufficient number of tubes surviving to continue the mission. The design

procedure for meteoroid resistance, previously discussed in Refs. 2 and 3 is adapted from the "minimum weight two sheet aluminum barrier" armoring method developed by Lundberg, Stern, and Bristow (6); the meteoroid environment characterization assumed is that of NASA SP 8013 (7).

Since this transmission line is integrated with a nuclear reactor that is not heavily shielded, the radiation environment is increased compared with the natural LEO environment; i.e., near the reactor, the tube assemblies are subject to greatly increased bombardment of high-energy ionizing radiation. The coaxial tube geometry, with a locally grounded tube surrounding an energized center conductor bombarded by high-energy particles, is similar to a Geiger counter tube. If the radiation induced ionizing current is low enough, and the ion energy is dissipated within the tube assembly at a faster rate than it is imparted, avalanche breakdown can be avoided. The radiation environment in the vicinity of SP-100 is not insignificant. For components in a dosage plane 25 m behind the shield the accumulated radiation dosage specification is:

Fast neutrons  $1.0 \times 10^{13}$  nvt

Operating gammas  $5 \times 10^5$  rad Si

over a 7 year period. Assuming a rad conversion factor of  $1 \times 10^{-8}$  for 2 to 10 MeV neutrons, this is equivalent to 1.6 rad/hr and 8.2 rad/hr respectively; yielding an ionizing current less than 0.001 pA/cc enclosed volume. Closer to the reactor this value would still be less than 1 pA/cc (immediately behind the shield).

#### COAXIAL TUBE ARRAYS

Even though the transmission environment differs from terrestrial practice, the objective of array and tube design is to transmit power at the allowed loss level with minimum line mass. To reduce the amount of conductor material and minimize vulnerable area, tube dimensions are kept as small as possible consistent with the electric field strength that can be withstood within the tube.

Tube diameter relationships are fixed by minimum E field (voltage gradient) considerations and equal conductor cross sections for forward and return paths (3). Conductor cross section is determined by current requirements and allowable loss as per terrestrial practice. As a result the transmission line parameters are expressible as a function of jacket wall thickness, the variable which links electrical design of the array to design of the meteoroid bumper which encloses it.

Because of minimum tube dimensions, field strengths within the annular gap are high; it is desirable to maximize the field strength that can be withstood within the tube without breakdown. The "working gradient" field strength used for design, namely, voltage applied across the gap (dc or rms ac) divided by gap dimension, is more a measure of overall electrical stress than a localized value. The actual gradient seen within the vicinity of standoffs, local surface discontinuities, etc. will be slightly higher; detailed field calculations have not yet been performed to quantify these peak values. The "working gradient" values selected may at first glance seem conservative, but transmission line practice is to operate normally at less than 1/2 to 1/3 BIL for reasons that have to do with statistics of extrapolation from small area electrode breakdown data to larger electrode area systems (8,9). For long transmission lines where large numbers of individual standoffs are used the "working voltage" selected for design must be significantly less than the

capability of any individual standoff or tested short length of cable. For example Jutniewicz (10), using the Weibull distribution methodology, has correlated test data showing that, for large numbers of individual elements, the working value must be reduced to less than 50 percent of the individual standoff's capacity to avoid line breakdown.

Further description of coaxial tubes, tube arrays, array design, and philosophy are given in Refs. 2 and 3. The array tubes are hollow, depending upon a vacuum or gas-filled gap for their isolation. For any given amount of conductor cross section and working gradient allowed, the hollow coaxial tube provides the least mass transmission since most of the tube's cross section is empty space. For the range of tube sizes and dimensions considered for tethering (power levels 10 to 100 kWe, separation distances 1 to 10 km), it is convenient to enhance standoff capacity by filling the gap with pressurized gas. Since the array has more than one tube it is also possible to make the annulus serve as a duct, conveying and circulating the gas as part of a cooling loop.

#### GAS-COOLED ARRAY

An illustration of the gas-cooled array is shown in Fig. 1. This would be the most likely form of high-voltage connection between SP-100 and the manned platform. It is similar to terrestrial CGIT except the gas is actively circulated to promote heat transfer and further suppress arcing. Freon or compressed air could be used, but sulfur hexafluoride provides the greatest dielectric strength. The gas flows in the annular void and around the spacers which are shielded. For circulation at least two tubes must be used: one for forward flow and one for return. The gas is pumped from the platform to the power source and back - in addition to transmission line cooling and insulation the flow can also be used to cool SP-100 power conditioning. Meteoroid penetration of any individual tube will cause that tube to fail; therefore, if spare capability is desired at least one extra tube must be provided. The array shown in Fig. 1 has four tubes. Two of them can fail before the array fails. Isolation valves and manifolding are provided in the gas circulation loop to ensure that in the event of a puncture, gas flow can be maintained in the remaining tubes. This array was characterized for tethering the SP-100 to a manned platform, according to the requirements given in Table I. Two power levels (100 and 300 kWe) were considered, for transmission line lengths 1 to 7 km. For purposes of the characterization study, two values of working gradient were examined: 25 and 50 kV/cm. Mass of tube array versus length for the entire array including meteoroid bumper, standoffs, and supports is depicted in Fig. 2.

The overriding advantage of the gas-cooled array is that despite a multiplicity of tubes it is the lightest for its electrical cross section, and could, due to the electrical and thermal equilibrium promoted by circulating the gas, potentially be capable of recovery from faults or arcing. Its chief disadvantage is that it is not mechanically flexible (like a cable) and so cannot be deployed from a reel or canister. It would have to be assembled in sections on site. Although the construction process would appear amenable to automation, the pertinent issues have not been studied to date. To prevent early breakdown from particle contamination, high standards of cleanliness would be required during its fabrication and subsequent assembly. Afterwards, extensive conditioning of the line would probably be required before being put into service.

## POLY-FILLED ARRAY

It would be desirable to make the hollow coaxial tube more like a cable. Instead of a stiff solid wall tube, a flexible tube, similar to coaxial transmission cables used for RF transmission might be used. With its coaxial gap filled with "solid" polymer insulation material, this flexible tube could be wound around a reel for easier deployment. An array of these tubes could be fully assembled and tested before being deployed. Furthermore, replacing gas insulation by filling the annulus with polymer insulating material of high-dielectric strength permits higher working gradients than are allowable with pressurized gas. For equivalent power level and transmission loss, this would permit reductions in tube diameter, cross section. It would also eliminate the pressurized gas system. Then it would be possible to meet the "fully redundant" design philosophy (one allowable failure) of Table I with only two tubes instead of three or four. A cross section of such a poly-filled array is shown in Fig. 3, alongside an equivalent gas-cooled array for comparison.

A family of poly-filled array designs was characterized for tethering the SP-100 to a manned platform according to the same requirements given in Table I. Two power levels (100 and 300 kWe) were considered, for transmission line lengths 1 to 7 km. For purposes of the characterization study, two values of working gradient were examined: 50 and 100 kV/cm. Mass of tube array versus length for the entire array including meteoroid bumper and supports is shown in Fig. 4. A specific gravity of 2 was assumed for the annulus filler.

The figure shows that the expected reduction in tube size and number of tubes does not necessarily translate to an overall reduction in array mass. Although the solid dielectric permits reduced tube size and conductor cross section, addition of the poly fill increases tube assembly mass by about 240 percent. This is due to minimum field geometry, yielding an annular void cross section which is about 76 percent of tube overall cross section. Filling this void with dielectric material almost triples tube mass. Reducing the tubes does not decrease the amount of meteoroid bumping that is required. With two tubes instead of four, the poly-filled array requires a higher level of protection than the four-tube array. Reduction of tube size does result in less vulnerable area but, due to the decreased wall thickness used to cause this reduction, the vulnerable area that remains must have increased protection, in the form of greater bumper thickness and spacing, to keep it from being punctured.

Table II gives a representative breakdown of the two array types. Shown are two 300 kWe arrays that are nearly equivalent in mass: a gas-cooled array at 25 kV/cm and a poly-filled array at 100 kV/cm, shown at a source-to-platform separation distance of 2 km. The comparative mass breakdown from this table is also illustrated by Fig. 5.

Figures 6 and 7 depict the comparison with gas-cooled arrays at 100 and 300 kWe respectively, over the range of separation distances 1 to 7 km. Due to higher working gradient and having only two tubes, the poly-filled array requires less than one-third the conductor mass. But this savings is negated by the annulus fill weight and larger meteoroid bumper that is required.

Over the 1 to 7 km distances considered, specific mass of both array types varied from about 1.5 to 60 kg/kWe. For the 2-km lines compared in Table II it is about 3 kg/kWe; a value that lies within the apparent mass range of other space power conditioning components. Since there is no apparent mass advantage for

the poly-filled array its comparison to a gas-cooled array must depend on other attributes such as simplicity, ease of deployment versus the perceived degree of difficulty for on-orbit assembly.

The radiation environment in the vicinity of SP-100 could exert some influence on the comparison. Although the metal and ceramic components of the gas-insulated line are relatively insensitive to this amount of radiation, there is a good deal of uncertainty over the long-term radiation tolerance of polymer dielectric materials to ionizing radiation under heavy electrical stress. If a poly-filled tube arcs once it fails permanently.

## DISCUSSION OF POWER CONDITIONING OPTIONS

The GES-derived SP-100 will employ static thermoelectric conversion, producing dc at up to 200 V. For tethering, a voltage boost is necessary to transmit power to the platform at reasonable weight. Minimum power conditioning required aboard the tethered SP-100 will be a "valved" inverter bridge with step-up transformer which operates at high frequency to minimize transformer core mass and limit the energy dissipated per cycle during a fault. Since the SP-100 source and its power conditioning cannot be serviced once operation begins and random failures must be expected, a key consideration is redundancy; ability of the SP-100/transmission network to transmit power over remaining elements when individual elements fail. The SP-100 delivers power through four regulated output ports that are parallel and independent. The coaxial tube array provides redundancy through its multiple tubes. The transmission line connection, or bus, enables the SP-100 to transmit power from any output through any tube. The resulting transmission network can be operated as either dc or single-phase ac.

## DC POWER TRANSMISSION

A schematic of the transmission network embodied as a dc power transmission line for tethering SP-100 is shown in Fig. 8. Power is processed through the network in three steps, viz: dc/dc conversion at high frequency (typically 20 kHz) to HV at the source (SP-100), transmission through coaxial tubes to the platform, and inversion at high frequency to user voltage. Two inverter stages are required; a ring bus is employed on each side of the transmission line to route HVDC current from one or more parallel converters through each coaxial tube to one or more parallel inverter units on the user side, so that failed converters or transmission tubes can be isolated. In the event of a fault the affected inverters are momentarily interrupted; the slower acting ring bus breakers reconfigure the transmission path. User interface is taken to be at the platform's inverter transformer.

DC operation appears to have many advantages. DC minimizes transmission line weight because it allows the most power to be transmitted per unit mass of transmission line at a given level of loss. The dc line mass is theoretically lower than the ac line by a factor of 1.41 (the square root of 2); a direct consequence of the peak to RMS voltage ratio. For the 2-km line presented in Table II that amounts to a savings of 257 kg. DC operation appears more amenable to modularizing with many independent parallel elements, since network synchronization requirements are much less rigorous. Reactive power compensation, stability, and synchronization problems are avoided - the inverter units can operate asynchronously and at different frequencies. However, dc requires more components to implement, particularly the rectifiers and capacitive

filtering which must operate in close proximity to the reactor.

#### AC POWER TRANSMISSION

Under some conditions operating the coaxial array as a redundant single-phase ac line may result in lower overall system mass. Tube mass is higher by a factor of 1.41 over the dc transmission but, for shorter lines that penalty might be low compared with the additional system weight from the components needed to make dc. A schematic of the transmission network embodied as an ac power transmission line is shown in Fig. 9. Power is processed through the network in two steps: inversion at high frequency to HVAC at the source (SP-100), ac transmission through coaxial tubes to the platform, and transformer stepdown to user voltage. One inverter stage is required, like the dc case a ring bus is employed on each side of the transmission line to route current from one or more parallel inverters through each coaxial tube to one or more parallel stepdown transformer units on the user side, so that failed inverters or transmission tubes can be isolated. One synchronous single phase is used to maximize redundancy and, in the event of tube or inverter failure, inter-operability through surviving components. Although the inverter bridges are separate units they are phase locked so that two outputs can be combined. For stability, the inverter switching frequency is reduced to 10 kHz, which corresponds to roughly  $\lambda/10$  for a 3-km line. Again, the user interface is taken to be at the platform transformers. There is good system incentive for ac operation since single-phase ac reduces to a minimum the number of components residing in the vicinity of the reactor. If capacitor KVAR is needed to stabilize the network, these components can reside below, aboard the relatively more benign environment of the manned platform. But network synchronization and fault response at high frequencies is more difficult.

A third variation of this network is presented in Fig. 10. It may be possible to further reduce the number of switching components at the power source by combining the parallel inverter units onto a common transformer and using that transformer as a splitter/combiner energy distribution bus. This would eliminate the need for a ring bus on both sides of the array. This approach requires each transformer tap to be breaker-protected and assumes that transformer windings are much less likely to fail than an individual inverter bridge or coaxial tube.

The three power conditioning/transmission network options discussed are summarized in Table III. Although individual components, their ratings, and mass are strongly influenced by the configuration chosen, no definitive mass estimate is available yet to discriminate between them. Selection will depend on the outcome of further definition and study.

#### CONCLUSIONS

For the range of working gradients considered reasonable with gas or polymer insulation over the coaxial tube dimensions involved, we have shown that the solid poly tube must have a breakdown strength more than four times that of the gas-filled tube for equivalent array mass. Over the 1 to 7 km distances considered, specific mass of both array types varied from about 1.5 to 60 kg/kWe. There is no apparent mass advantage for the poly-filled array; therefore its comparison to a gas-cooled array must depend on other attributes such as simplicity, ease of deployment versus the perceived degree of difficulty for on-orbit assembly.

Although individual components, their ratings, and mass are influenced by which network configuration is chosen, no definitive mass estimate is available yet to discriminate between the three power conditioning/transmission options discussed. Selection will depend on the outcome of further definition and study.

#### REFERENCES

1. Bloomfield, H.S., and Heller, J.A., 1986, "A Feasibility Assessment of Nuclear Reactor Power System Concepts for the NASA Growth Space Station," Advancing Toward Technology Breakout in Energy Conversion (21st IECEC), Vol. 3, American Chemical Society, Washington, D.C., pp. 1924-1932.
2. Bents, D.J., 1985, "Tethered Nuclear Power for the Space Station," Energy for the Twenty-First Century (20th IECEC), Vol. 1, Society of Automotive Engineers, Warrendale, PA, pp. 1.210-1.227. (NASA TM-87023).
3. Switzer, C.A., and Bents, D.J., 1987, "Coaxial Tube Array Space Transmission Line Characterization," NASA TM-89864. (To be published in the 22nd IECEC).
4. Raitt, W.J., Berkey, F.T., Burt, D.A., Tarbert, R., Kelley, M.C., Pickett, J., and Jost, J., 1988, "SPEAR-1: A Sounding Rocket Payload to Study High Voltage Current Collection from the Ionosphere at Low Earth Orbit (LEO) Altitude," AIAA Paper 88-0427.
5. Foley, T.M., 1987, "SDI Suborbital Launch Yields Data for High Power Platform Design," Aviation Week & Space Technology, Vol. 127, No. 25, Dec. 21, pp. 26-27.
6. Lundberg, J.F., P.H. Stern, and R.J. Bristow, 1965, "Meteoroid Protection for Spacecraft Structures," Boeing Co., Seattle, WA, D2-24056 (NASA CR-54201).
7. Cour-Palais, B.G., 1969, "Meteoroid Environment Model 1969 (Near Earth to Lunar Surfaces)," NASA SP-8013.
8. Cooke, C.M., and Cookson, A.H., 1978, "The Nature and Practice of Gases as Electrical Insulators," IEEE Transactions on Electrical Insulation, Vol. EI-13, No. 4, pp. 239-248.
9. Brookes, A.S., 1974, "The Weibull Distribution: Effect of Length and Conductor Size of Test Cables," Study Committee 21 of CIGRE, Electra, No. 33, pp. 49-61.
10. Juchniewicz, J., Mazurek, B., and Tyman, A., 1979, "The Effect of the Number of Spacer Insulators on the Breakdown Voltage of Vacuum Insulation," IEEE Transactions on Electrical Insulation, Vol. EI-14, No. 2, pp. 107-110.

TABLE I. - REQUIREMENTS SPECIFICATION USED FOR DESIGN STUDY

Power, kWe . . . . .	100 and 300
Transmission distance, km . . . . .	1 to 7
Allowable loss, percent . . . . .	2 BOL
No greater than . . . . .	5 EOL
Meteoroid survival probability . . . . .	$\geq 0.999$
Over a period of, years . . . . .	10
Number of catastrophic failures allowed . . .	>1 tube failure
Radiation environment	
Fluence:	
Neutron, nvt . . . . .	10 exp 5
Gamma, rad . . . . .	5x10 exp 5
Exposure, years . . . . .	7

TABLE II. - TWO-300 kWe, 2-km TRANSMISSION LINES

	Gas-cooled	Poly-filled
Working gradient used, kV/cm	25	100
Transmission voltage, kV	5.4	12.8
Number of tubes surviving EOL	2	1
Out of number tubes BOL	4	2
Tube OD, mm	12.46	7.42
Tube wall thickness, mm	0.383	0.228
Density of annular fill, g/cm <sup>3</sup>	0	2
Spacer assemblies per tube	595	0
Bumper wall thickness, mm	0.119	0.086
Bumper circle diameter, mm	157	386
Bumper minimum gap, mm	63	185
Mass of largest meteoroid armored against, g	0.0051	0.006
Electrical resistance, $\Omega$ /km	1.95	5.49
Electrical capacitance, pF/km	55	120
Electrical inductance, $\mu$ H/km	254	254
Array mass summary		
Conductor (tube core + jacket)	628	111
Annulus fill	0	263
Spacer assemblies	0.75	0
Meteoroid bumper + supports	345	652
Total, kg	974	1026

TABLE III. - THREE POWER CONDITIONING/TRANSMISSION CASES

Source side power conditioning		
DC transmission	AC transmission	AC transformer-combined
Inverter low voltage asynchronous switching modules 20 to 50 kHz	Inverter low voltage phase-locked switching modules 10 kHz	Inverter low voltage phase-locked switching modules 10 kHz
Step-up transformers 20 to 50 kHz	Step-up transformers 10 kHz	Step-up splitter/combiner transformer, multiple windings and taps 10 kHz
Bridge rectifiers	-----	-----
Smoothing filters	-----	-----
Transmit station switching/protection ring bus	Transmit station switching/protection ring bus	Step-up transformer tap breakers
4-tube coaxial array dc transmission line	4-tube coaxial array one-phase ac transmission line	4-tube coaxial array one-phase ac transmission line
Platform side power conditioning		
-----	KVAR compensation (if required)	KVAR compensation (if required)
Receive station switching/protection ring bus	Receive station switching/protection ring bus	Stepdown transformer tap breakers
Inverter high voltage asynchronous switching modules 20 to 50 kHz	-----	-----
Step-down transformers 20 to 50 kHz	Step-down transformers 10 kHz	Step-down splitter/combiner transformer, multiple windings and taps 10 kHz
User interface at transformer output	User interface at transformer output	User interface at transformer output

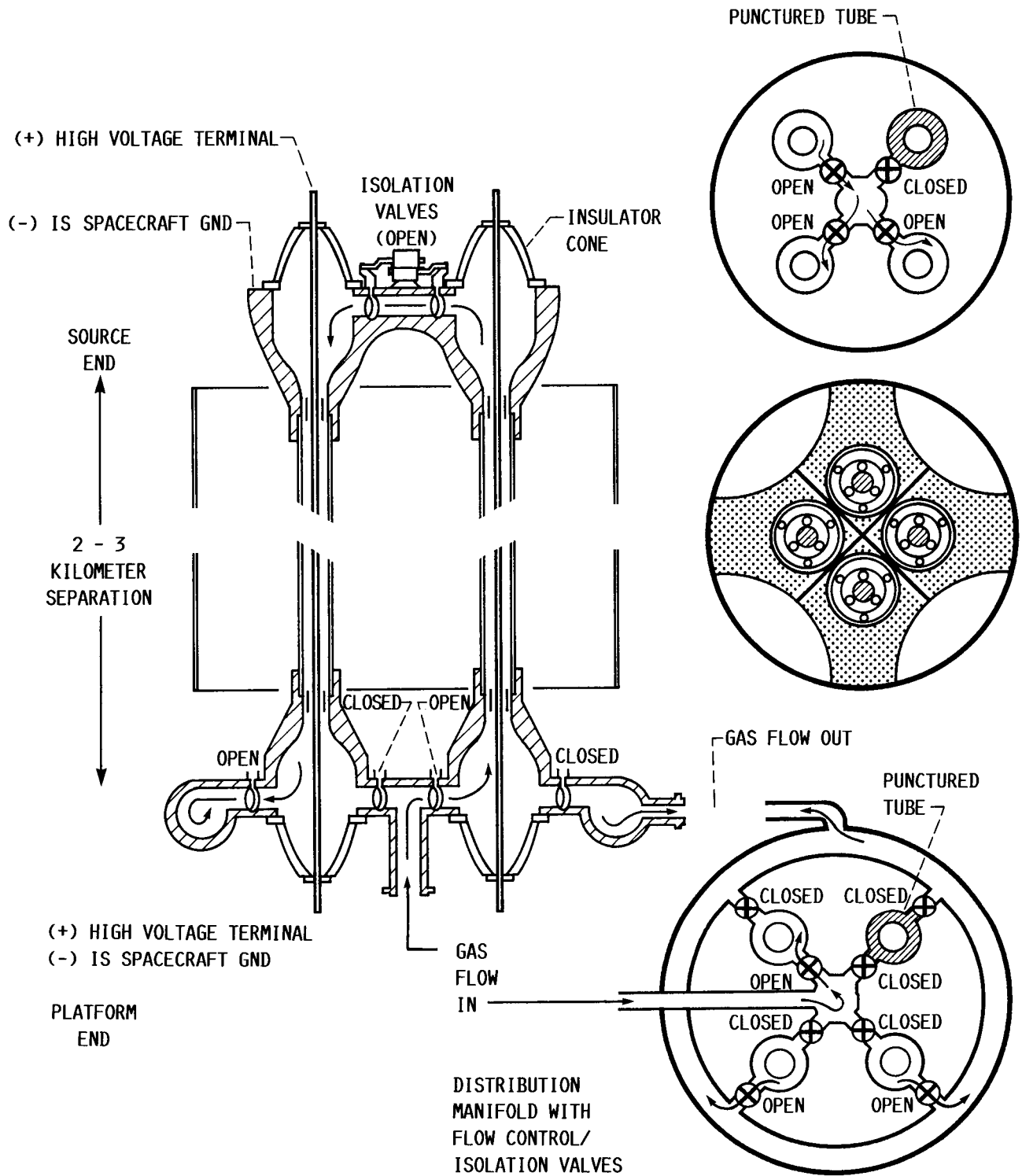

FIGURE 1. - GAS-COOLED COAXIAL ARRAY SPACE TRANSMISSION LINE.



MASS OF COAXIAL TUBE ARRAY  
 SPACE TRANSMISSION LINE:  
 GAS-COOLED HVDC  
 WORKING GRADIENT 25 AND 50 KV/CM  
 100 AND 300 KWE

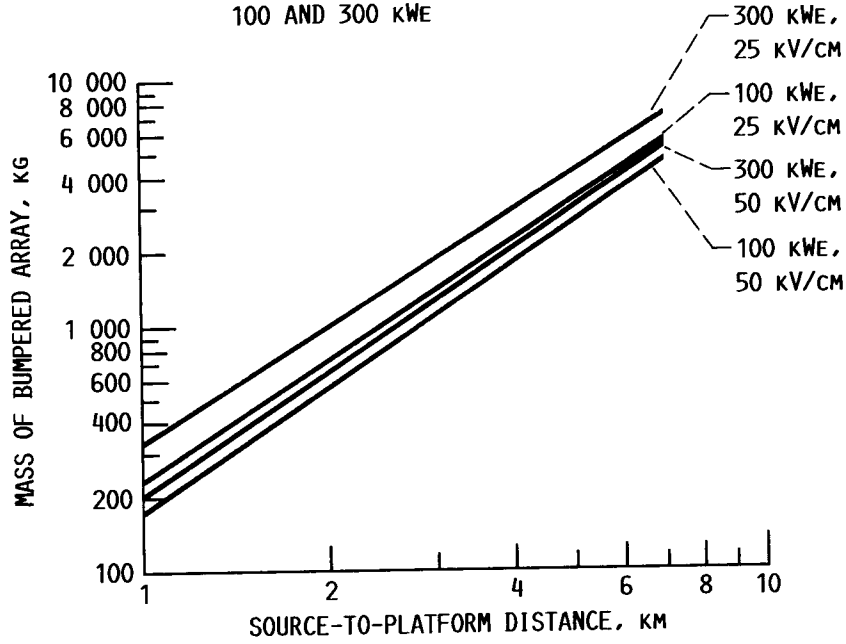

FIGURE 2. - GAS-COOLED ARRAYS.

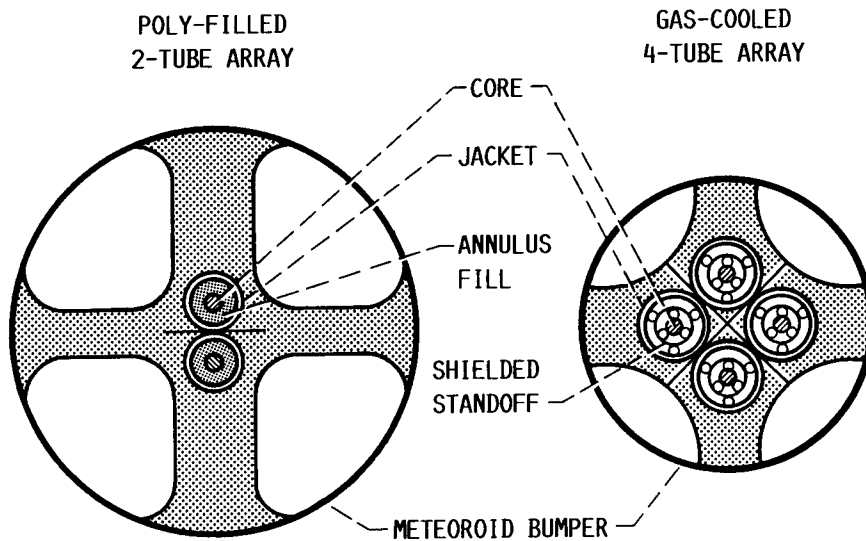

FIGURE 3. - SOLID POLYMER INSULATION-FILLED (POLY-FILLED) COAXIAL TUBE ARRAY (A GAS-COOLED ARRAY OF EQUIVALENT RATING IS SHOWN ALONGSIDE FOR COMPARISON).

MASS OF COAXIAL TUBE ARRAY  
 SPACE TRANSMISSION LINE:  
 POLY-FILLED HVDC  
 WORKING GRADIENT 50 AND 100 kV/cm  
 100 AND 300 kWE

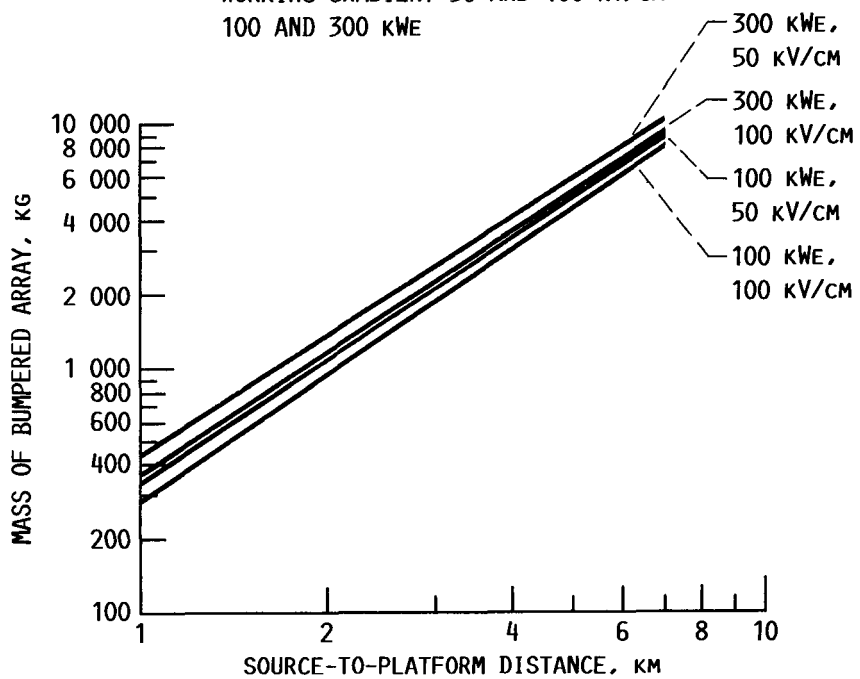

FIGURE 4. - POLY-FILLED ARRAYS.

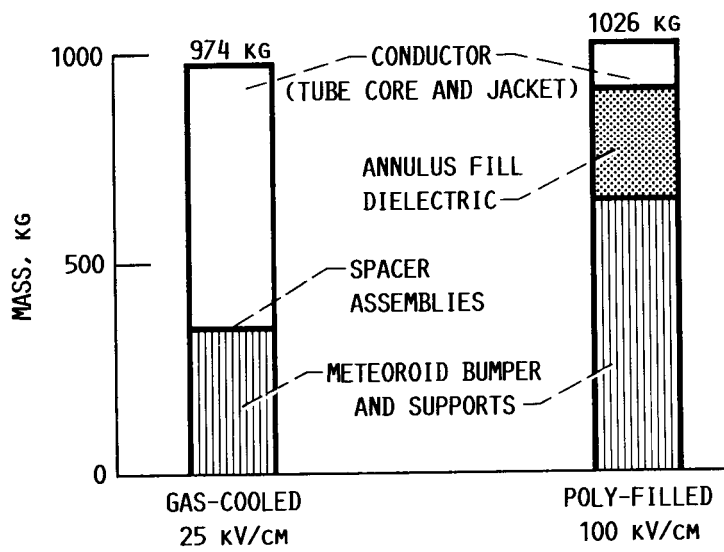
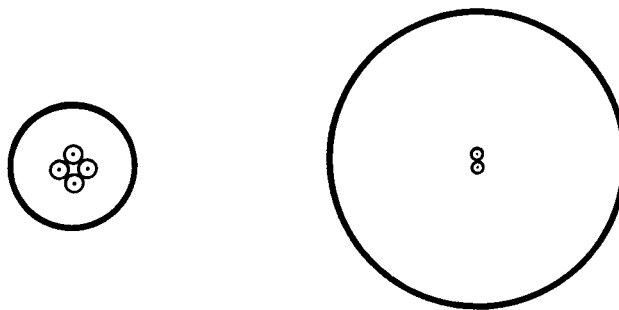

FIGURE 5. - MASS BREAKDOWN OF EQUIVALENT 2 KM GAS-COOLED AND POLY-FILLED ARRAYS (300 KWE, FROM TABLE II).

COMPARISON AT 100 kWE, 2% LOSS

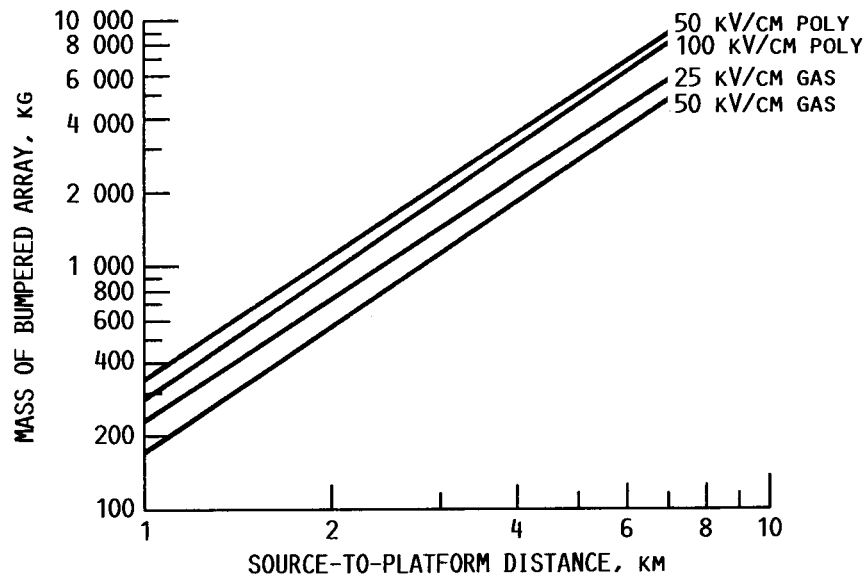

FIGURE 6. - GAS-COOLED VERSUS POLY-FILLED AT 100 kWE.

COMPARISON AT 300 kWE, 2% LOSS

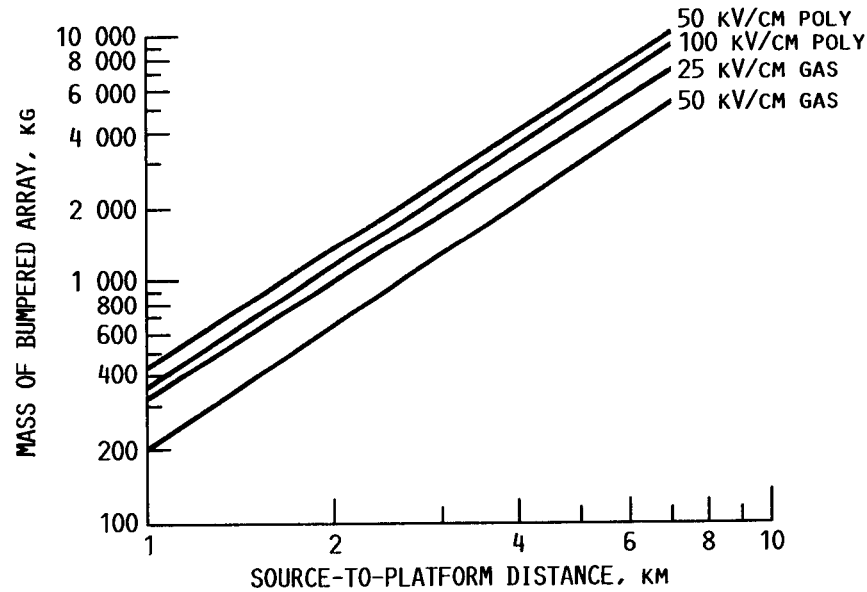
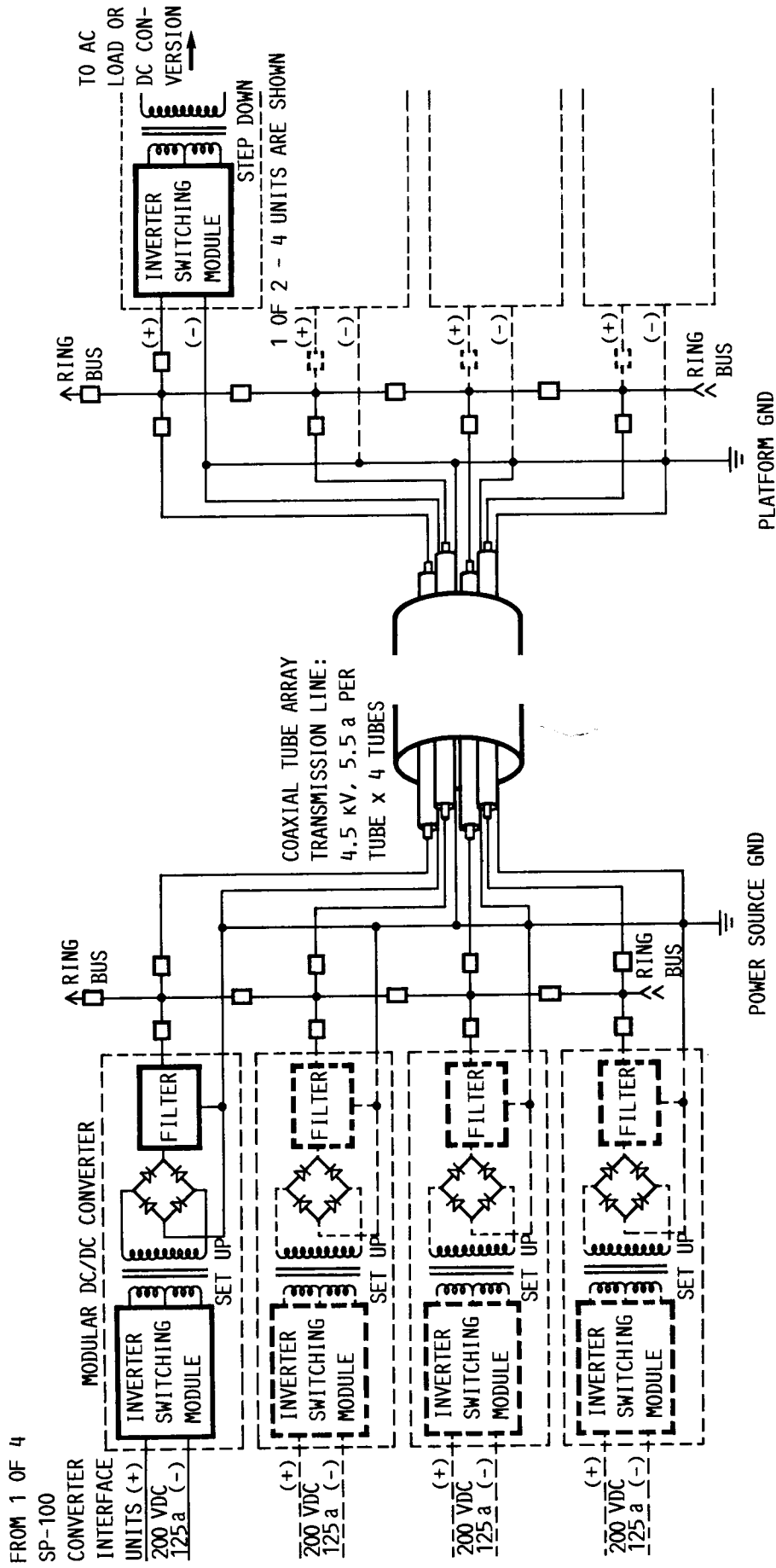

FIGURE 7. - GAS-COOLED VERSUS POLY-FILLED AT 300 kWE.

TETHERED NUCLEAR POWER



PLATFORM INTERFACE

SP-100 INTERFACE

FIGURE 8. - DC POWER TRANSMISSION.

TETHERED NUCLEAR POWER

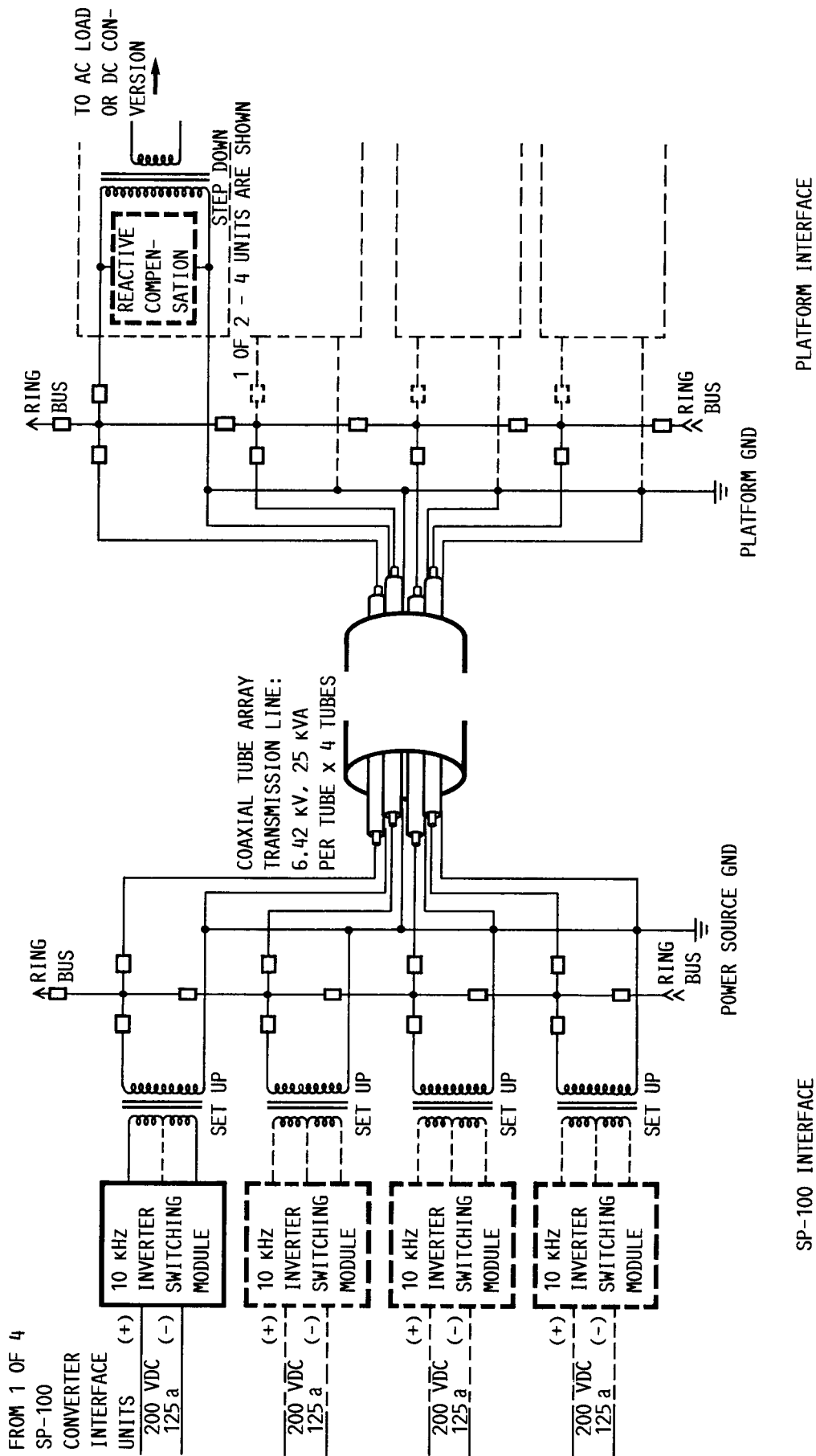
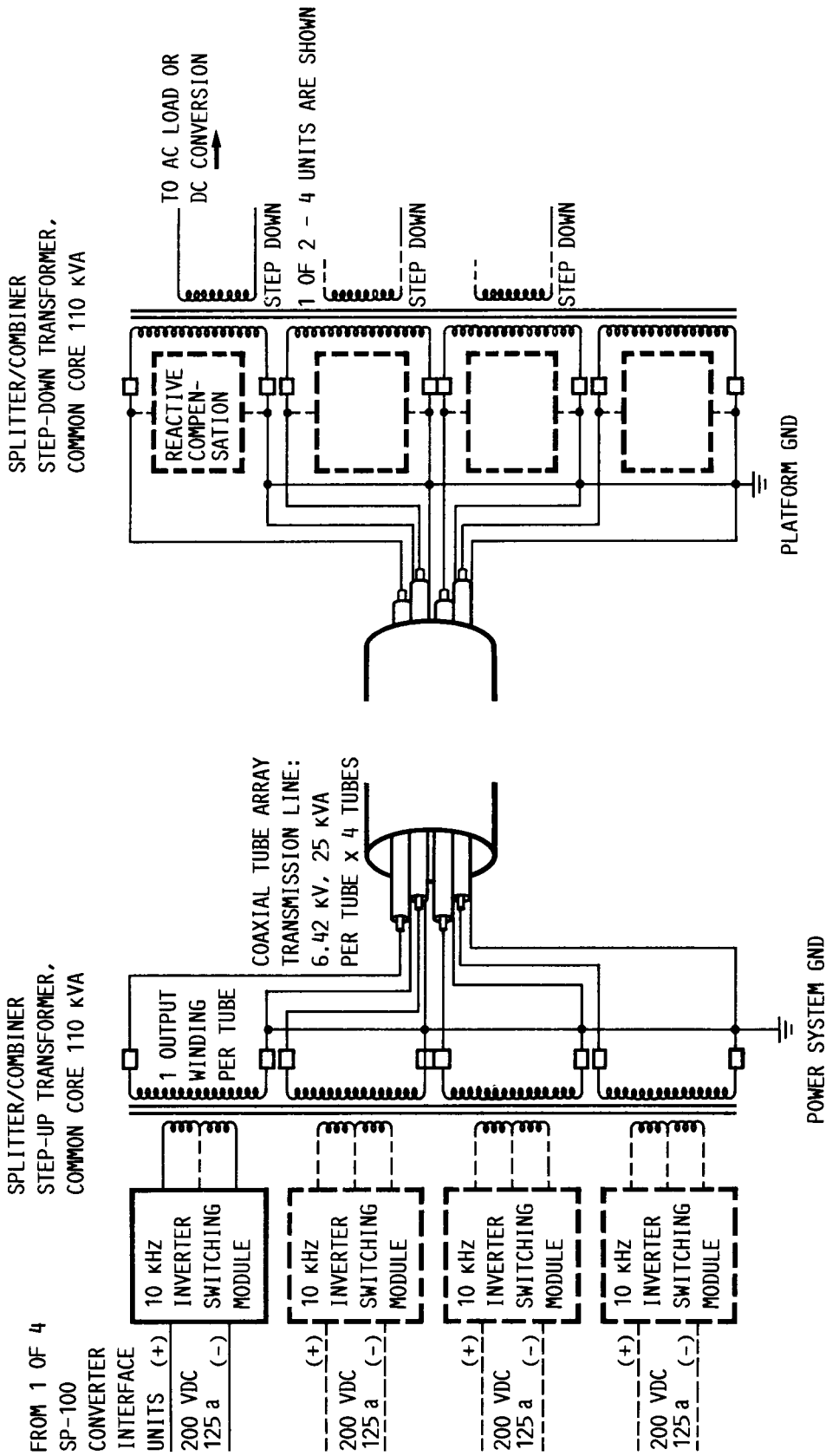

FIGURE 9. - AC POWER TRANSMISSION.

TETHERED NUCLEAR POWER



SP-100 INTERFACE

PLATFORM INTERFACE

FIGURE 10. - AC POWER TRANSMISSION - TRANSFORMER COMBINED.

1. Report No. NASA TM-100864		2. Government Accession No.		3. Recipient's Catalog No.	
4. Title and Subtitle Power Transmission Studies for Tethered SP-100				5. Report Date	
				6. Performing Organization Code	
7. Author(s) David J. Bents				8. Performing Organization Report No. E-4081	
				10. Work Unit No. 586-01-11	
9. Performing Organization Name and Address National Aeronautics and Space Administration Lewis Research Center Cleveland, Ohio 44135-3191				11. Contract or Grant No.	
				13. Type of Report and Period Covered Technical Memorandum	
12. Sponsoring Agency Name and Address National Aeronautics and Space Administration Washington, D.C. 20546-0001				14. Sponsoring Agency Code	
15. Supplementary Notes Prepared for the 23rd Intersociety Energy Conversion Engineering Conference, cosponsored by the ASME, AIAA, ANS, SAE, IEEE, ASC, and AIChE, Denver, Colorado, July 31 - August 5, 1988.					
16. Abstract The tether/transmission line connecting the SP-100 to space station presents some unorthodox challenges in high-voltage engineering, power transmission, and distribution. Although it is believed that relatively straightforward application of terrestrial HV technology can answer most of these challenges there are several new issues, problems unique to this concept which require further study. The line, which doubles as a structural element of this unusual spacecraft, will convey HVDC from SP-100 to the platform in low-earth orbit, an environment where the local plasma is sufficient to cause breakdown of exposed conductors at potentials of only a few hundred volts. Its anticipated several years operation, and continuously accumulating exposure to meteoroids and debris, raises an increasing likelihood that mechanical damage, including perforation, will be sustained in service. The present concept employs an array of gas insulated solid wall aluminum coaxial tubes; a conceptual design which showed basic feasibility of the SP-100 powered space station. Practical considerations of launch, deployment and assembly have lead to investigation of reel-deployable, dielectric insulated coaxial cables, versus automated stacking/assembly for the tubes. To be competitive the dielectric would have to operate reliably in a radiation environment under electrical stresses exceeding 50 kV/cm. The SP-100/transmission line/platform high-voltage interfaces are also considered. Starting from the source (SP-100), whose power output is low voltage, a high-frequency inverter and its connections are used to simultaneously provide voltage boost, circuit switching and fault protection.					
17. Key Words (Suggested by Author(s)) Space power tethers Nuclear space power Power cables Electrical power transmission			18. Distribution Statement Unclassified - Unlimited Subject Category 20		
19. Security Classif. (of this report) Unclassified		20. Security Classif. (of this page) Unclassified		21. No of pages 16	22. Price* A02