

N88-21477

DEVELOPMENT OF A MOTORIZED CRYOVALVE FOR THE CONTROL
OF SUPERFLUID LIQUID HELIUM

K. R. Lorell, J-N. Aubrun, D. F. Zacharie, and D. J. Frank*

ABSTRACT

Recent advances in the technology of infrared detectors have made possible a wide range of scientific measurements and investigations. The Infrared Astronomy Satellite (IRAS), the Cosmic Background Explorer (COBE), the Space Infrared Telescope Facility (SIRTF), and the Infrared Space Observatory (ISO) are all examples of this new generation of instruments. One of the requirements for the use of sensitive IR detectors is that the entire instrument be cooled to temperatures approaching absolute zero. The cryogenic cooling system for these instruments is commonly designed as a large dewar containing liquid helium which completely surrounds the apparatus. Thus, there is a need for a remotely controlled, motorized cryovalve that is simple, reliable, and compact and can operate over extended periods of time in cryo-vac conditions. This paper describes the design, development, and test of a motorized cryovalve with application to a variety of cryogenic systems currently under development at Lockheed.

INTRODUCTION

Recent advances in the technology of infrared detectors have made possible a wide range of scientific measurements and investigations. The Infrared Astronomy Satellite (IRAS), the Cosmic Background Explorer (COBE), the Space Infrared Telescope Facility (SIRTF), and the Infrared Space Observatory (ISO) are all examples of this new generation of instruments. One of the requirements for the use of sensitive IR detectors is that the entire instrument be cooled to temperatures approaching absolute zero. The cryogenic cooling system for these instruments is commonly designed as a large dewar containing superfluid liquid helium (SFHe), which completely surrounds the apparatus. SFHe is capable of providing cooling to temperatures as low as 1.5 K.

Because these experiments are typically flown in space and because many layers of insulation as well as a vacuum shell are required to keep heat leaks to a minimum, the valves that control the filling, venting, and routing of the cryogen are inaccessible. Thus, there is a need for a remotely controlled, motorized cryovalve which is simple, reliable, compact,

*Lockheed Palo Alto Research Laboratory, Palo Alto, California

and can operate over extended periods of time in a vacuum at temperatures in the range 1 K to 400 K. In addition, valve operation must produce minimal thermal energy, because any heat input to the cryogen will significantly shorten the useful lifetime of the instrument.

This paper describes the design and test of a 1/4-in.-diameter motorized cryovalve with an orifice of 4.4 mm for the Lockheed Independent Development (ID) SFHe dewar. This dewar, shown in Figure 1, has a 200-L SFHe tank that surrounds the experiment volume and is capable of cooling the enclosed instrument to temperatures as low as 1.6 K. In addition, the dewar uses a special toroidal tank containing normal-boiling-point helium that acts as a thermal guard during extended ground-hold periods. Figure 2 is a plumbing schematic of the system and shows the location of the motorized cryovalves.

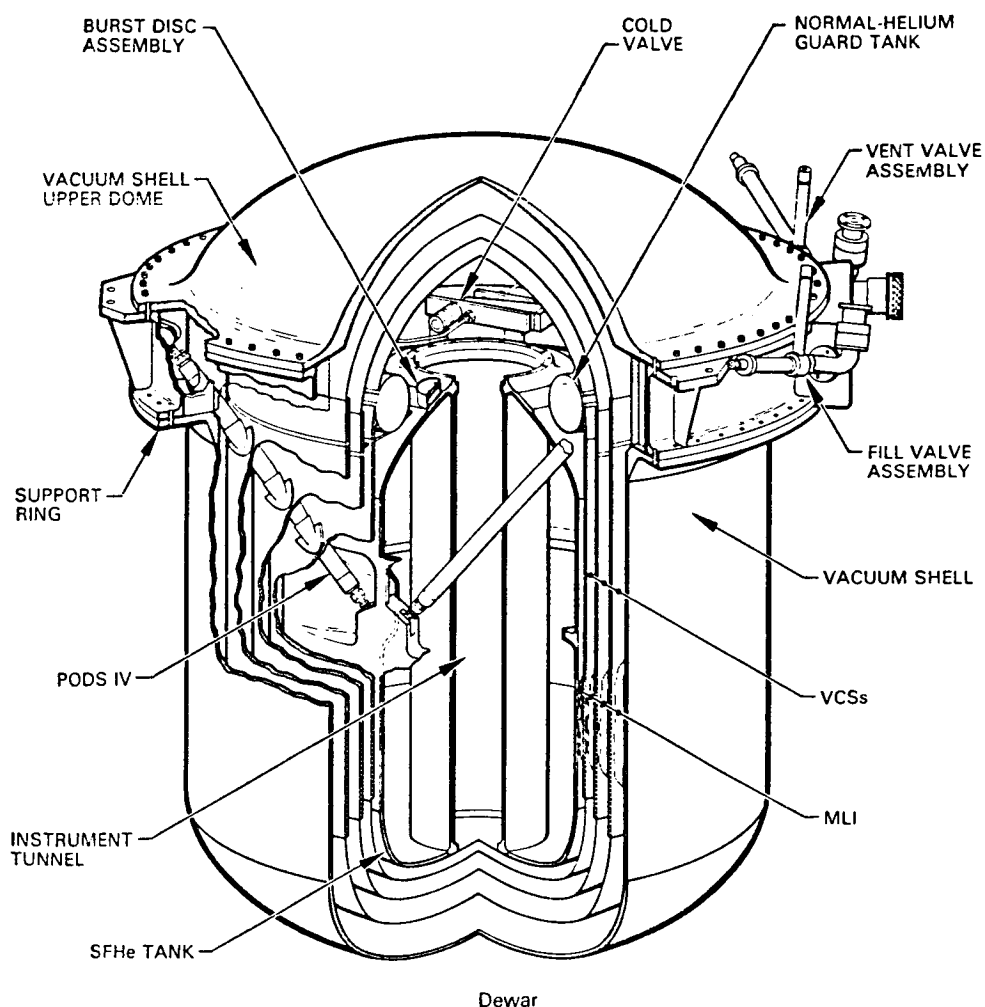

Figure 1 Cross Section of the Lockheed ID SFHe Dewar

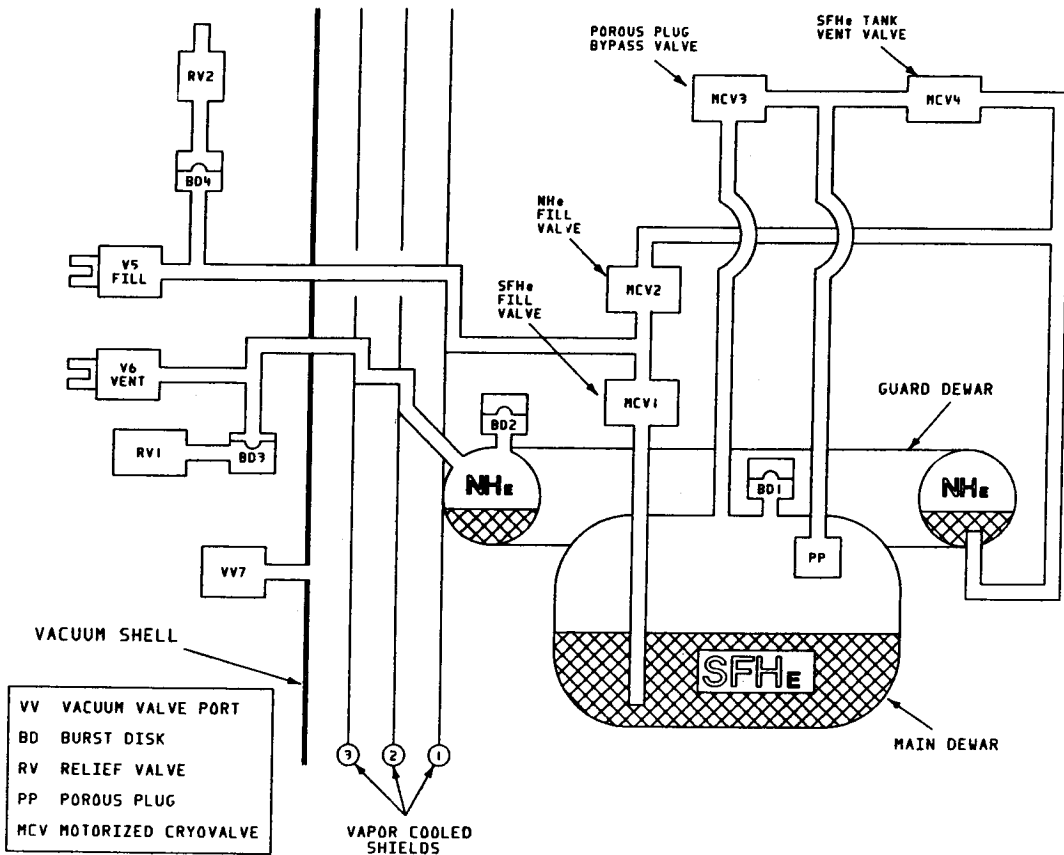

Figure 2 Plumbing Schematic for the Lockheed ID Dewar

CRYOMECHANISMS

This section describes some of the design considerations for electromechanical devices which must be operated in cryo-vac conditions.

Mechanical

Mechanical design considerations for cryomechanisms center around two primary concerns: (1) absolute and relative (between mating parts) dimensional changes as the mechanism is cooled from room temperature to operating temperature and (2) lubrication (or friction reduction) for rotating parts. These two problems can interact when a bearing is pressed into an aluminum housing and the differential in coefficients of thermal contraction between the steel race and the aluminum housing can cause the bearing to seize when cold. The use of gearboxes is especially critical, because they involve lubrication, rotating parts, and close dimensional tolerances.

Electrical

Electrical components for use in cryo-vac must be selected to minimize the impact of the severe operating environment. For example, motors must have the appropriate mechanical properties and preferably be of the brushless or stepper design, because brushes have been shown to be unreliable in a vacuum. In addition, motor sizing must be conservative because of substantial increases in friction related to ineffective (or nonexistent) lubrication, and dimensional changes. Sealed switches can be a problem because the hermetic seal usually involves pressurizing the device with nitrogen gas, which freezes at liquid-helium temperatures. The size, current-carrying capacity, and number of wires required to communicate with the mechanism are critical because wires represent a thermal leak from the outside and because incorporating wires in the dewar complicates the thermal design and arrangement of the insulation blankets.

Thermal

The two primary thermal concerns in the design of cryomechanisms are (1) thermal energy generated by the operation of the mechanism and (2) thermal leaks, which are most often related to the electrical connections to the outside. The energy generated by the mechanism can usually be minimized by careful sizing of the actuation device. Because the wires leading to the outside of the dewar represent a continuous source of thermal input, minimizing the number of required wires is essential. In addition, the lower the current the wire is required to carry, the smaller the diameter and resultant heat leak. Thus, the sizing of the actuation device should be heavily weighted in favor of the minimum current configuration capable of meeting the requirements.

Reliability

The reliability of a cryomechanism is a critical issue, even for devices that are not flight hardware. Virtually all such mechanisms become components of a much larger, more complex system and are usually located in the most isolated part of a cryogenic system, inside a vacuum shell and numerous layers of insulation and cooled shields. The dewar is often required to remain cold for long periods of time before launch or use in an experiment. This dormant period can last from several days to many months. In addition, the cryomechanism is often in the critical path for successful operation of the experiment; for example, cryomechanisms are typically used to position optical elements and to operate cryogen fill and vent valves.

Magnetic Fields

Although the usual reason for cooling an apparatus to cryogenic temperatures has to do with increasing the sensitivity of measurements in the infrared, a novel NASA/Stanford University/Lockheed experiment (Gravity Probe-B) utilizes the quantized property of magnetic fields in a film of superconducting lead niobate to provide an extremely sensitive readout of the orientation of the axis of rotation of a gyroscope. Cryomechanisms

located near the section of the dewar that is sensitive to magnetic fields must therefore operate with a minimum of stray flux. This dictates the use of the smallest, simplest actuation device which meets the basic mechanical requirements, so that the flux around the mechanism can be minimized.

REQUIREMENTS FOR THE SFHe CONTROL VALVE

In addition to the concerns discussed in the previous section, additional constraints and requirements were addressed in the design of the SFHe control valve.

Mechanical Requirements

Mechanical design is driven by two main concerns: (1) the valve sealing mechanism itself must be leak-proof to superfluid helium, and (2) the mechanism that opens and closes the valve must be precise in both position and force exerted on the seal and must operate reliably near absolute zero.

The conventional approach to the first problem is to apply a large force (in the case of a 1/4-in. valve, about 1000 N) to push the stem against the valve seat. This may produce plastic deformation of the stem and of the seat, and it is thus essential to carefully control the amount of force exerted by the drive mechanism in order to prevent permanent damage and loss of sealing performance. This mechanism must be able to function at ordinary temperature as well as the specified operating temperature to allow preflight checks. Thus dimensional change due to temperature variation and differences in coefficients of thermal expansion between the various materials can be severe, and the design must be as insensitive to these changes as possible.

Producing such a large seat force requires some kind of gear reduction system to minimize the size of the drive motor and to prevent back driving when no power is applied to the motor. This is a critical design problem because it involves lubrication, rotating parts, and close dimensional tolerances. The required force may be obtained by directly closing the valve with the gear/drive-motor system. However, it is then difficult to produce the exact force level because, as soon as there is contact between stem and seat, the relationship between current in the motor and force on the seat depends strongly on such factors as friction, compliance of the gear train and stem/seat assembly, and the angular position of the motor shaft.

Electrical Requirements

Besides the general problems posed by using electrical components in a cryo-vac environment, the design of the cryovalve had to meet additional requirements specific to the ID dewar application. Reducing the cryogen losses was especially important; most of these losses result from the thermal conductivity of the wires carrying signals and drive current to the

motor across the dewar interface. The low temperature prevents the use of certain electronic components. For instance, brushless motors that use semiconducting Hall-effect detectors for commutation cannot be used because these devices cannot operate at cryogenic temperatures. Similarly, most of the electronic components have to be situated in a warmer part of the spacecraft and lead wires must be used to communicate with the mechanism sensors and actuators.

Sealing Requirements

The valve must be able to effectively seal against SFHe down to temperatures of 1 K. The maximum allowable leak rate across the seat is 10^{-6} scc/s* with no detectable leakage through the valve body.

Design Optimization

The various requirements are obviously coupled, and trade-offs have to be considered between power dissipation, opening/closing time, gear ratio and gear-box complexity and reliability, and motor-drive system complexity. Additional constraints are the size and weight of the device. Since no lubrication is possible, reducing the number of bearings and bushings is important as well as reducing the transverse loads applied to these bearings and bushings to minimize friction and stiction.

CRYOVALVE DESIGN

Compression Spring

The approach taken for Lockheed cryo valve is very similar to that used for the valves on automotive engines. The valve seat force is provided by a compressed spring and valve opening is accomplished using a lever-and-pivot arrangement. Figure 3 shows the principle of operation and the location of the spring and lever mechanism relative to the valve. This concept has the advantage that the seat force is constant, predictable, and repeatable. While designs using motor torque to drive the stem into the seat may be more compact, the drive unit is more highly stressed and the seat force, which is critical to a good seal in the case of superfluid helium, is much less predictable. Belleville washers were used because they provided the required force in a relatively compact package. In addition, the spring constant was such that the increase in force over the range of motion of the stem was minimal.

Spindle/Tape Drive

The difficulty in implementing a motor-driven valve was in developing enough force with a small motor to be able to compress the seat spring in order to open the valve. Even at room-temperature conditions using a conventionally lubricated drive unit, the force/motor-size problem is difficult to solve. Figure 4 illustrates how the drive unit is connected to the lift arms so that the small motor/gearbox combination produces the

*scc - standard cubic centimeter per second

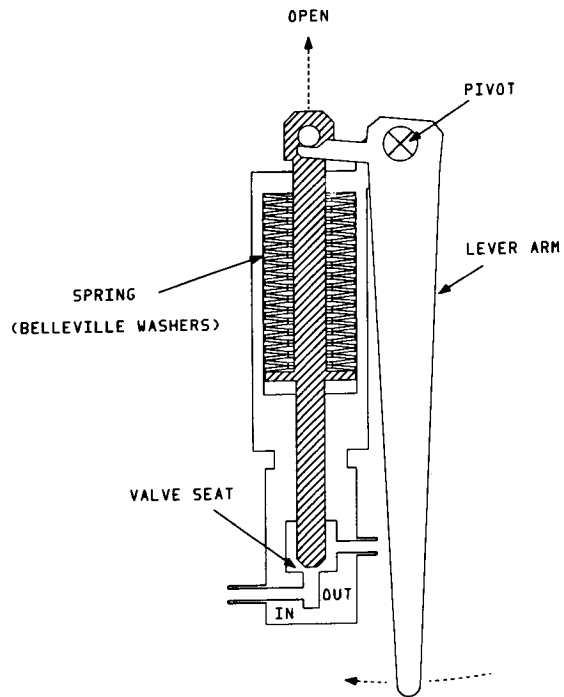

Figure 3 Valve Actuation Showing Spring and Lever Mechanism

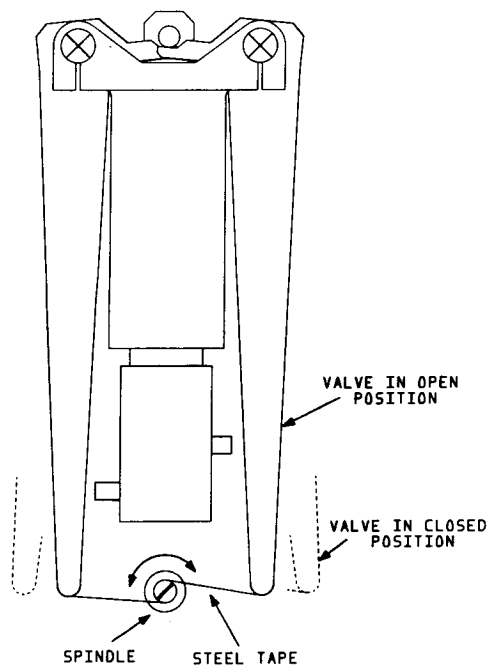

Figure 4 Spindle and Steel-Tape Drive for Lift-Arm Actuation

required actuation torque. The lift arms are designed to have a 6-to-1 lever ratio, thereby reducing the required actuation force from 956 N to 160 N (or 80 N per arm).

The spindle and tape arrangement shown in Figure 4 has several advantages. It is a simple and direct way of translating rotary motion into linear motion. It requires no pivots or gears and attaches directly to the lift arms. Finally, because the tape pulls on the spindle from both sides, there is zero net side force on the gearbox output shaft. This is especially important because the gearbox must run without lubrication and the friction losses through the gearbox are a noticeable part of the motor torque requirement.

The other aspect of the spindle and tape drive is the means of balancing the forces on each of the lift arms. If the tape were attached directly to each of the arms, even a slight decentering of the spindle with respect to the arms will cause the arms to have very different engagement forces at the lift pin. This problem was solved as shown in Figure 5. Instead of being directly attached to the arm, the metal tape is made as a continuous loop, and thus the tension force of each arm is automatically balanced.

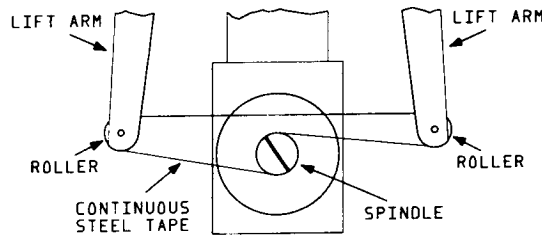

Figure 5 Continuous Steel-Tape Drive

Motor/Gearbox

The torque required to actuate the valve mechanism is provided by a stepper-motor/gearbox combination as seen in Figure 6. The motor is a four-pole stepper with a nominal output torque of 0.007 N-m. The 500:1 planetary gearbox combined with the 1.25-cm-diameter spindle generates a maximum theoretical tension force in the tape of 285 N, which is approximately 3 times the calculated required force. However, because of the high friction losses in the gearbox, which are especially apparent at cryogenic temperatures, a conservative design philosophy was used to size the motor. It was subsequently determined that the motor need not run at maximum current, due primarily to the extra torque capability.

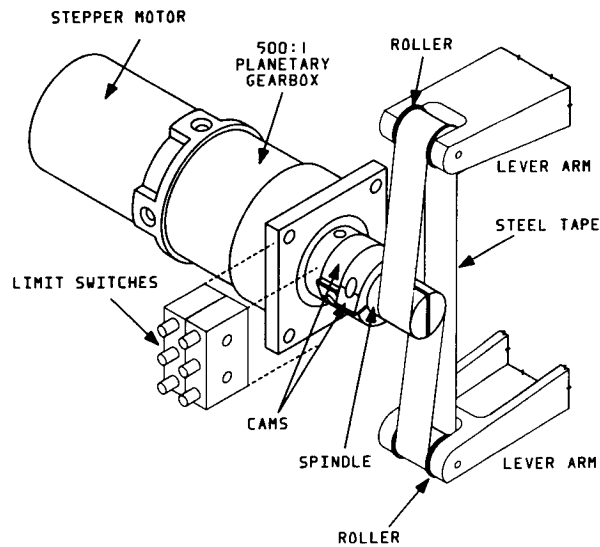

Figure 6 Motor and Gear-Box Drive Mechanism Detail

Because lubrication has been a continuous source of difficulty on previous cryomechanism designs, the motor and gearbox operate completely free of lubricant. Before integration, both units are completely disassembled and thoroughly cleaned. The planetary gearbox utilizes only two ball bearings, located on the output shaft. The remaining components turn on bushings. The motor has two Bar-Temp bearings, both of which are also cleaned. Since the speed of operation is so low, the total number of duty cycles in the lifetime of a given unit is limited, and the motor has excess torque capability, no operational problems caused by the lack of lubricant have developed.

The motor is controlled by an off-the-shelf motor drive integrated circuit, which is integrated into an electronics package and designed to control up to five valves. Completion of the open and close cycles is controlled by two limit switches that are actuated by cams located just behind the spindle and the gearbox output shaft. The cams and limit switches are shown in Figure 6. A schematic diagram of the control electronics is shown in Figure 7.

Valve

The valve itself is a commercially available sealed-stem unit manufactured by Nupro. Because the valve body is stainless steel and the bellows surrounding the valve stem are hermetically sealed to the body, essentially no modification was required for use in a cryogenic system. The valve body acts as the central structure for the attachment of the actuation mechanism. The drawing in Figure 8 and the photograph of Figure 9 show the assembled cryo valve.

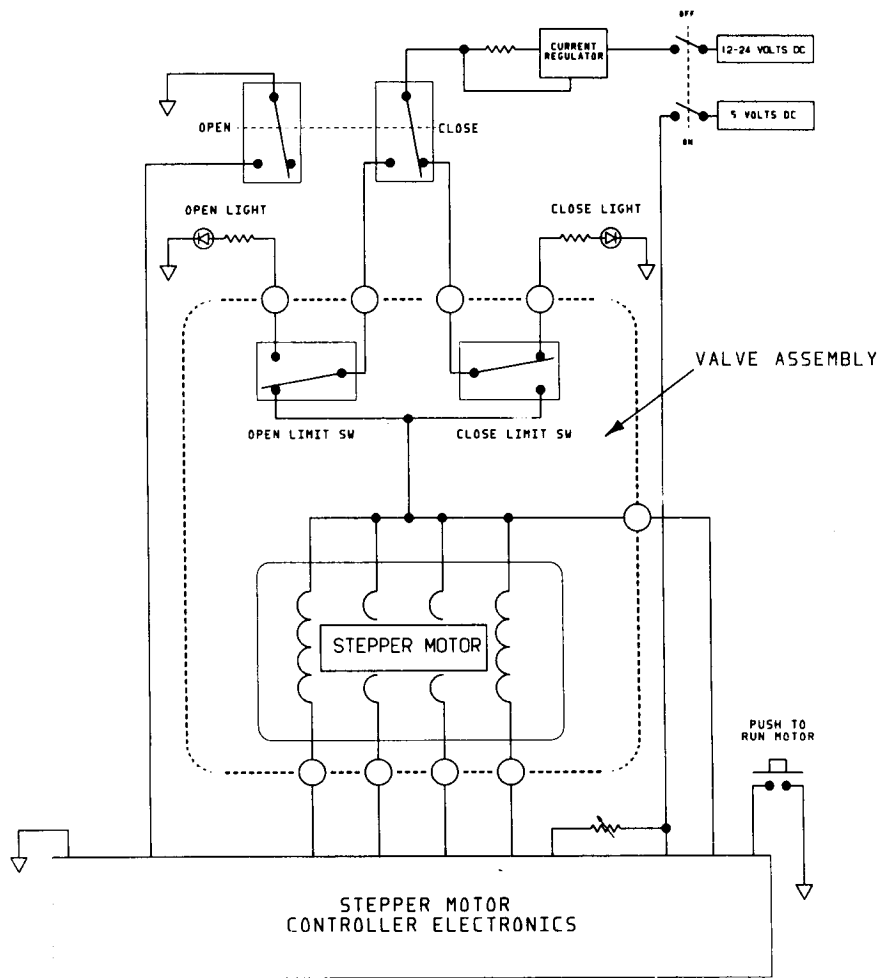

Figure 7 Motor Drive Electronics Schematic

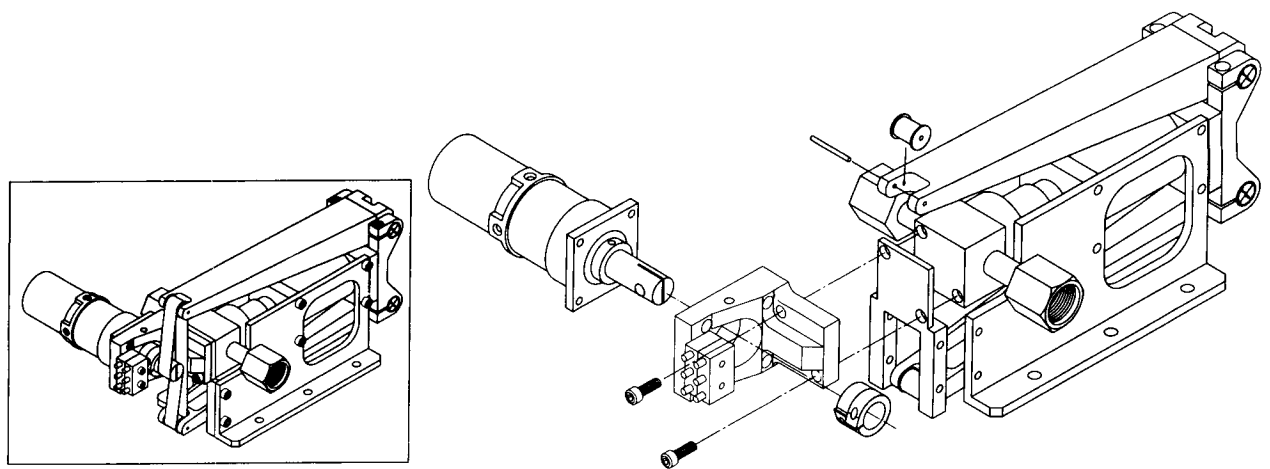

Figure 8 Cryovalve Assembly

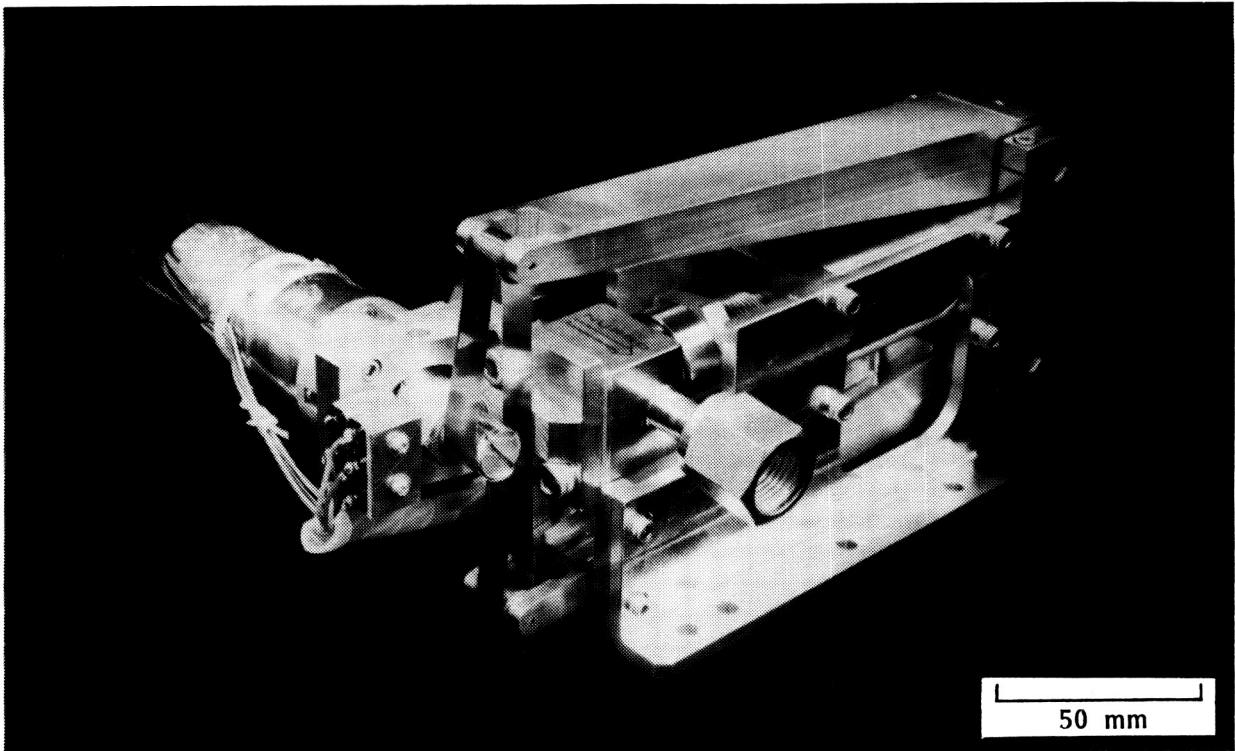

Figure 9 Lockheed Cryovalve

TESTING/PERFORMANCE EVALUATION

Objective

The primary objective of the tests was to determine whether or not the basic goal of an electrically driven mechanism to actuate a valve capable of sealing a cryogenic liquid had been met. However, a number of other objectives associated with the operation of the valve and the mechanism were also explored by the test program. These objectives are:

- Measurement of leak rate and degradation of leak rate as a function of number of operation cycles
- Measurement of leakage from the valve body assembly
- Determination of the minimum current required to operate the motor under increased load (friction) conditions at cryogenic temperatures
- Determination of thermal energy (approximate) dissipated to cryogen
- Observation of behavior of the stainless steel tape drive and potential embrittlement at cryogenic temperatures

Although the operational environment is SFHe at or below a temperature of 2.1 K, tests on the cryovalve were performed using liquid nitrogen (LN₂) at 77 K and LHe at 4.2 K. All cryogenic testing is time consuming and expensive, but using LN₂ and LHe is considerably simpler and less

expensive than testing with SFHe. Test results described by Siebert indicate that leak-tight performance at LN₂ temperatures is directly correlated with leak-tight performance under SFHe conditions (Ref. 1).

Test Apparatus

An apparatus was designed and fabricated to perform ambient and cold cycling of the cryo valve assemblies. The test setup included instrumentation to measure temperatures at various locations on the valve assembly and to measure leak rates both at the valve seat and from the valve body. Each of the valves to be used in the ID dewar was subjected to a minimum of 50 cycles at LN₂ with leakage rates measured every 10 cycles. Leak rates were also measured following each cooldown or warmup of the valve assembly. One of the valves was tested at LHe temperature as well.

The test apparatus is shown schematically in Figure 10. The valve assembly can be seen located inside of an evacuated container which is submerged in either LN₂ or LHe. Access to the valve is obtained by separating the upper and lower halves of the container, which remain sealed during a test. Because the valve is in a vacuum, valve cooling takes place primarily though conduction by the support bracket. The container was

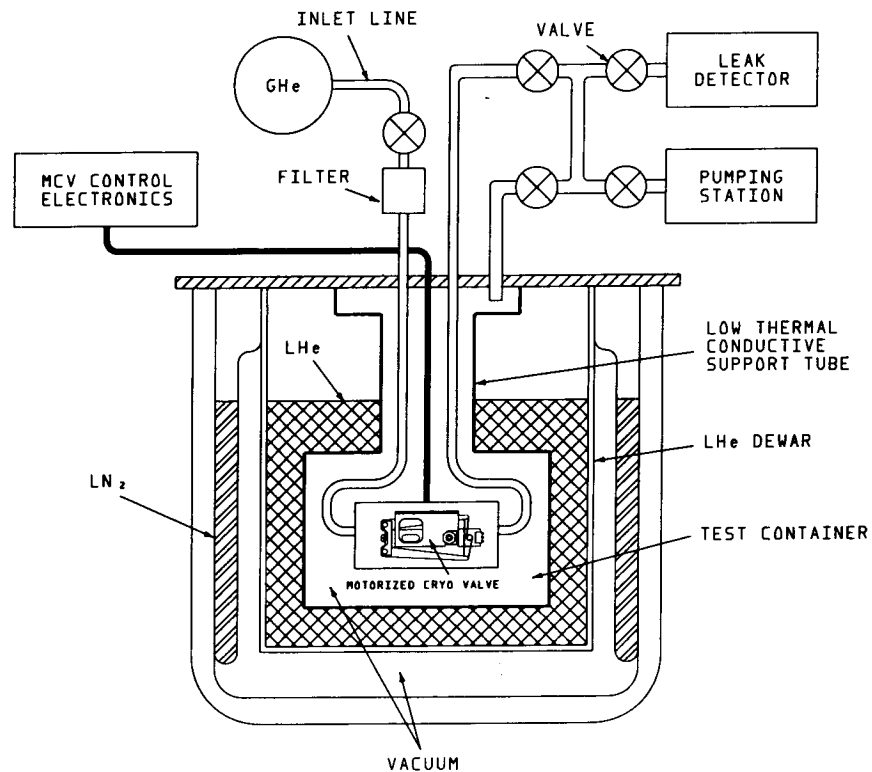

Figure 10 Cryo Valve Test Apparatus

backfilled with gaseous He to improve the cooldown rate and to help condense He in the lines at the valve seat during leak checking at LHe temperature.

Temperature sensors were installed at three locations: the support bracket, the valve body, and the case of the motor. The motor temperature measurement was of special interest because continued cycling of the valve at LN₂ resulted in a noticeable temperature rise in the motor. Under actual operating conditions, this phenomenon is not important because (1) the valve is cycled very infrequently, and (2) the amount of heating at SFHe temperatures is about a factor of 10 less than at 77 K because the resistance of the motor windings has decreased by that amount. Nevertheless, during the LN₂ tests, the cycle rate was controlled so that the motorcase temperature did not exceed 100 K. Figure 11 shows a valve installed in the test container before the vacuum seal is applied and Figure 12 shows the test setup in the laboratory.

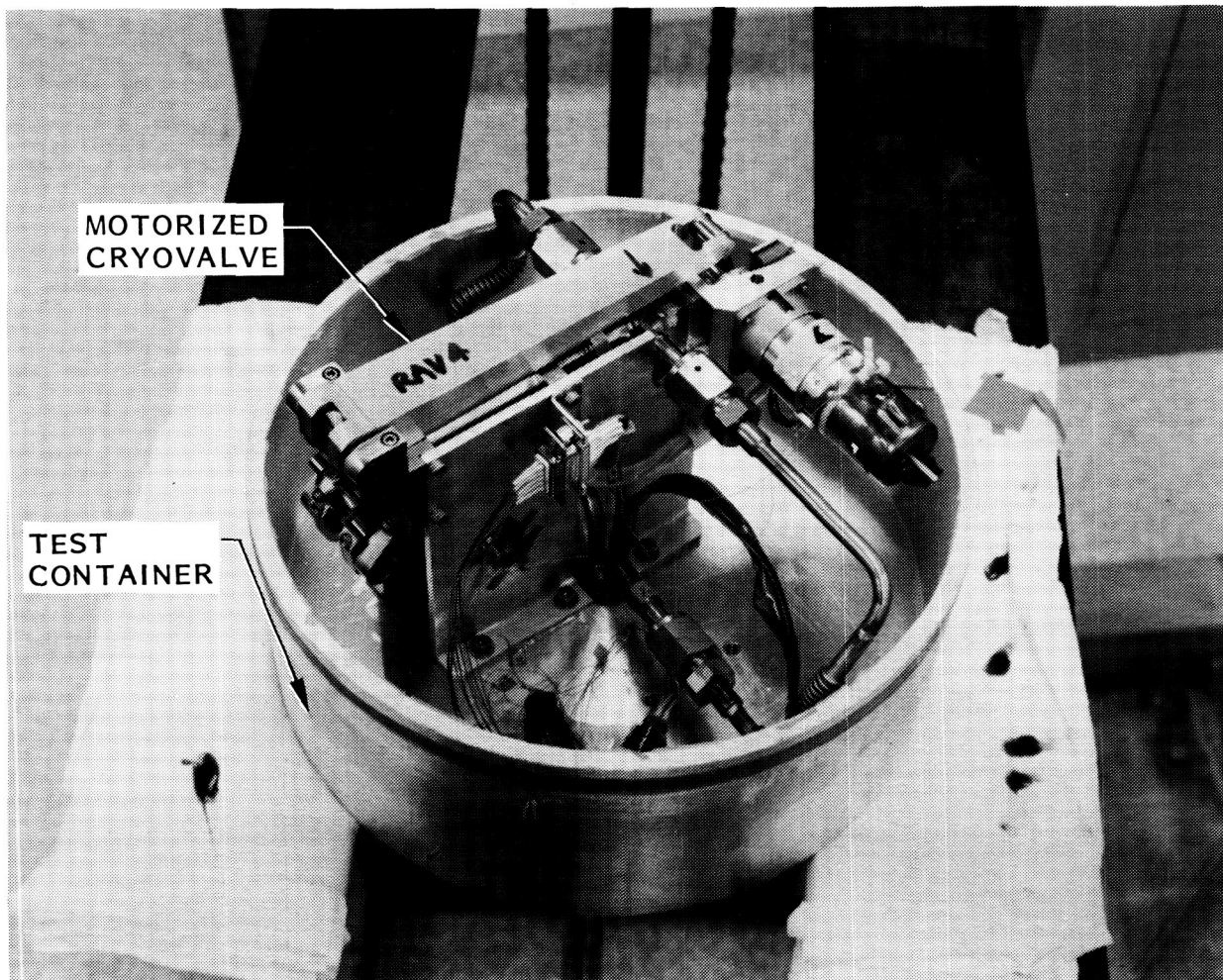

Figure 11 Cryo valve Mounted in Test Container

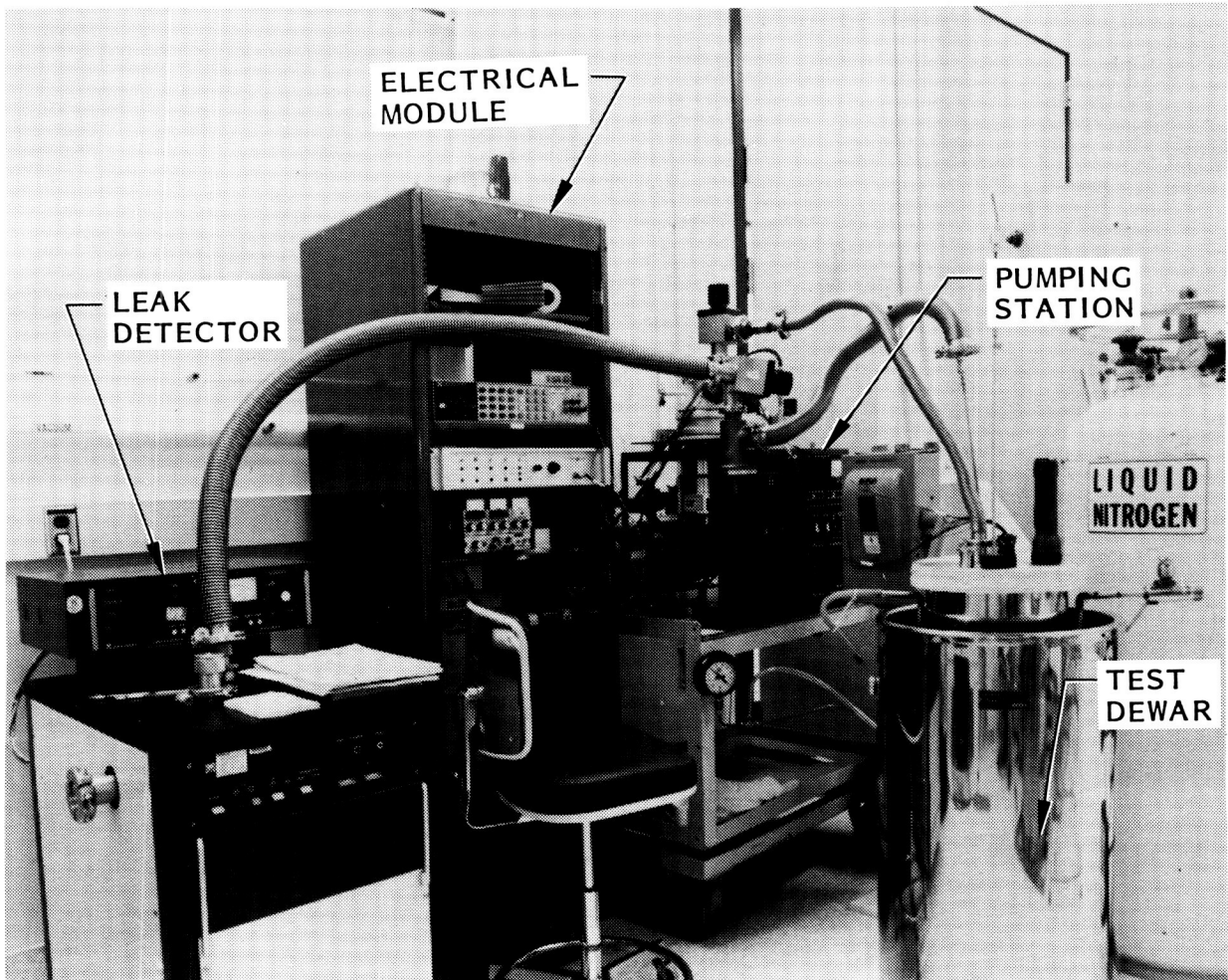

Figure 12 Laboratory Arrangement of Test Apparatus

Leak Checking

A leak detector with a sensitivity of 10^{-10} scc/s was used for all tests. The valve-seat seal was tested by first evacuating both the inlet and outlet lines with the valve open, then closing the valve. The input line was then pressurized with 20-psig gaseous He, and measurements of the leak rate were made at 1 min intervals for 3 min.

Leak checking of the hermetic seal between the bellows and the valve body required opening the valve and pressurizing the valve inlet and outlet lines with gaseous He. Leaks from the valve body into the evacuated test container were then examined with the leak detector. The same three leak rate measurements at 1 min intervals were used.

Background levels of gaseous He in the 10^{-8} scc/s range were found. They were due primarily to residual helium from the most recent leak check which was not completely pumped out of the lines. This was intentional in that the time required to pump to the 10^{-10} level would have been prohibitive. Since the acceptable leak rate is in the 10^{-6} scc/s range, a background of 10^{-8} is sufficiently small.

Test Results

Five valves were tested; all were tested at ambient and LN_2 temperatures, but only one was tested at LHe temperature. None of the valves had detectable leaks in the valve body. Leak rates through the valve seats at LN_2 temperature ranged from not measurable (below 10^{-8} scc/s) to a high of 10^{-6} scc/s. One of the unexplained phenomena observed during LN_2 cold cycling was the variability of the leak rate. When a valve exhibited a high leak rate (that is, a 10^{-6} scc/s range), cycling the valve one or more times would cause the leak rate to return to the 10^{-8} scc/s range or lower. One possible explanation is that the 1000-N seat force may have been detrimental to the copper valve stem. Deformation of the stem was observed on posttest disassembly, indicating that the seat force was excessive. If the stem did not locate itself on the seat in exactly the same way during each close cycle, it is possible that a small leak could develop.

A modification was made to the lift rod and the spring housing on the valve that was tested at LHe temperature so that the stem relative to the seat could be better controlled. When this valve was retested at LN_2 , only one of the leak rates was larger than 10^{-8} scc/s, the high leak rate excursion being 8×10^{-7} scc/s.

Tests at LHe temperature showed no detectable leakage (i.e., a leak rate at or below the background 10^{-8} scc/s rate) with the exception of one cycle. Measurements during this cycle indicated no detectable leakage for the first minute. By the third minute, the leak rate had increased to 1.5×10^{-5} scc/s (slightly out of specification); however, on the subsequent and all later cycles, the leak rate returned to its previous low value. The leakage behavior was very different during this cycle. Typically, when one of the valves had a detectable leak, the leakage appeared as soon as the helium was introduced upstream of the valve and remained constant throughout the 3-min period.

Conclusions and Comparisons

On the basis of these test results, the valve design was considered acceptable for laboratory testing of the ID dewar. As previously mentioned, four units were required. Figure 13 shows the units installed during fit-checking of the plumbing.

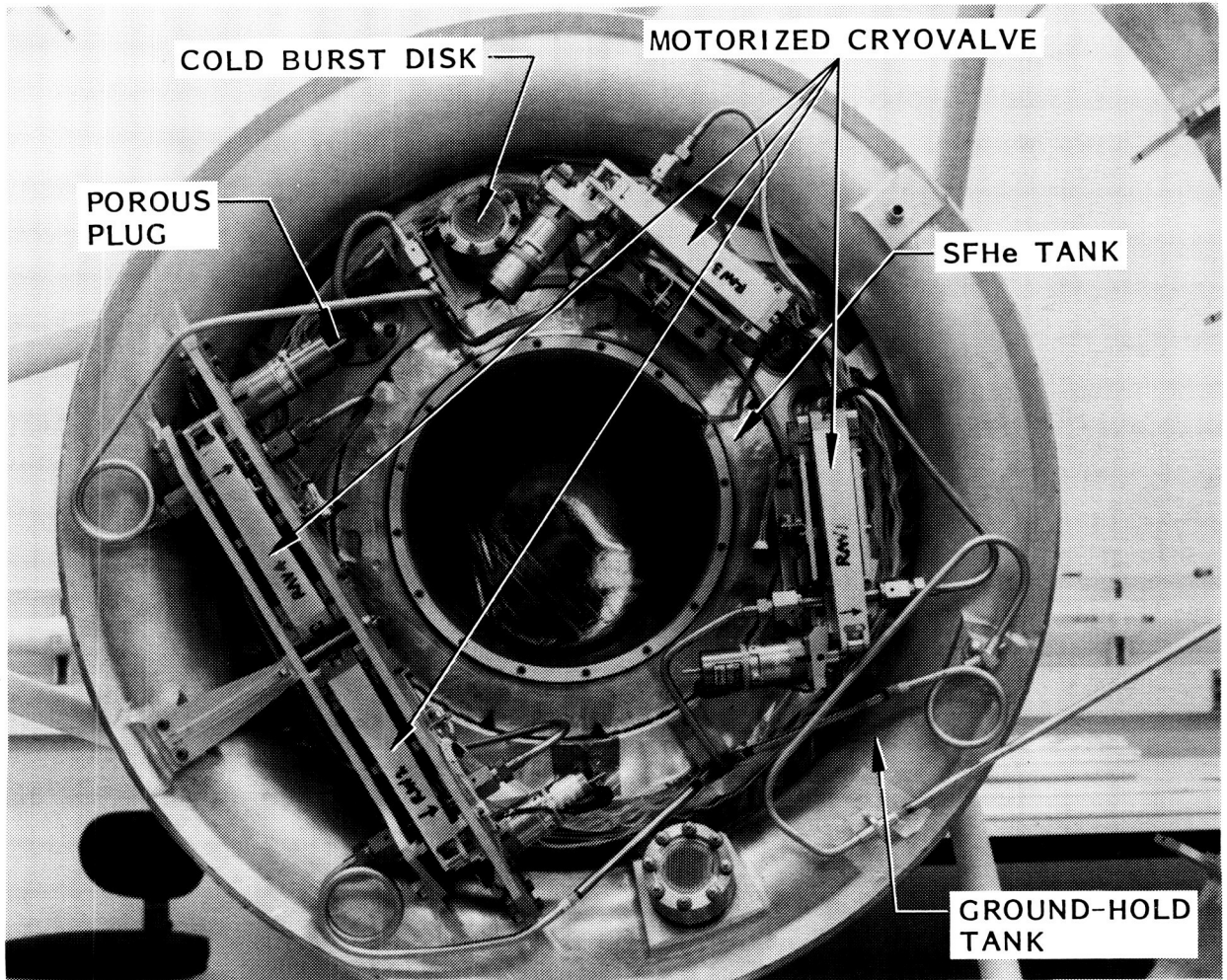

Figure 13 Motorized Cryovalve Installed on ID Dewar

A number of other valve assemblies have been developed or are in the development stage for various NASA or European Space Agency (ESA) programs. Table 1 shows some of the features of these valves and the one described in this paper. The unit developed by Ball Aerospace Division (BASD) (Ref. 2) has been qualified for space and has been used on IRAS and COBE. The units by Utah State University (USU) (Ref. 3) are in the development stage and the characteristics shown in the table will most likely change by the time they are produced for NASA for the Superfluid On-Orbit Transfer Experiment to be flown on the Shuttle. All of these units (BASD and USU) use Nupro bellows valves, as does the Lockheed unit. The unit built for ESA is also shown (Ref. 4).

ORIGINAL PAGE IS
OF POOR QUALITY

Table 1 VALVE CHARACTERISTICS

	LMSC	BASD	USU	USU	MBB
Valve Orifice Diameter (mm)	4.4	7.9	7.9	15.9	9.0
Assembly Weight (kg)	1.3	1.6	0.9	2.6	0.9
Envelope					
Length (cm)	8.6	16	7.6*	9.7*	9.1
Width (cm)	1.4	10.9	7.6*	11.4*	7.6
Height (cm)	19.3	10.9	2.5*	5.8*	5.0
Open/Close Time (s)	30.0	8.0	8.0	2.7	.06
Seat Force (N)	957	1669	1335	4005	205
Valve Throw (mm)	2.5	2.5	3.2	5.1	2.4
Current (A)	0.33	?	0.3	0.6	0.42

*Driving mechanism only

Acknowledgement

The authors want to thank Mr. W. W. Lee of the Lockheed Palo Alto Research Laboratory for his assistance in assembling the valves' electrical module, and for a number of important design modifications.

REFERENCES

1. J. F. Siebert et al. "Experimental Comparison of Helium Leak Rates and Detection Techniques at Temperatures Above and Below the λ -Point," Proceedings of the Space Cryogenics Workshop, p.89 (1984).
2. J. F. Siebert et al., "Development of a Launchworthy Motor-Operated Valve for Containment of Superfluid Helium," Proceedings of ICEC9, p.182 (1982).
3. Superfluid Helium On-Orbit Transfer Preliminary Design Review, Vol. 1, 1987.
4. F. Fuchs and A. Seidel, "Directly Operated Valve for Space Cryostats," Cryogenics Vol. 27, p. 15 (1987).