

EXPERIENCE WITH DUPLEX BEARINGS
IN NARROW ANGLE OSCILLATING APPLICATIONS

D.D. Phinney,* C.L. Pollard,* and J.T. Hinricks*

INTRODUCTION

Duplex ball bearings are matched pairs on which the abutting faces of the rings have been accurately ground so that when the rings are clamped together, a controlled amount of interference (preload) exists across the balls.

Because duplex ball bearings have no internal clearance and no freedom for the rings to shift relative to each other, they are vulnerable to

- Radial temperature gradients (inner rings hotter or colder than outer rings) that change the preload and can cause it to disappear or become excessive.
- Blocking in oscillating applications
- Increased sensitivity to contamination

Experience with the last two problem areas on a gimbal that used duplex bearings at both ends of its inner axis is discussed. Motion on this axis would consist of rotation to a pointing direction, followed by narrow angle oscillation (less than ± 0.3 deg) at a six cycle per minute rate that could last as long as several years in one position. This is considered a difficult lubrication problem because the low speed and narrow angular range prevent formation of significantly thick lubricant films. The bearings operate continuously with boundary lubrication. Although bearings with one BASD space lubricant demonstrated their ability to operate successfully for many years in a narrow-angle dithering mode, a different lubricant with improved properties was to be used for the gimbal application. Consequently, it was decided that an accelerated thermal vacuum life test should be conducted.

This paper describes the test apparatus and results and presents the rationale for reducing a multi-year life test on oil-lubricated bearings to less than a year. Of the five bearing sets tested, two performed very well, one was marginal, and two were unacceptable. The diagnostic effort on one of these latter sets and the results of additional tests demonstrating the validity of the findings are described herein. Finally, details of the actual gimbal bearing installation and some of our experiences with it are covered.

DESCRIPTION OF TEST APPARATUS

Five life test duplex bearing sets were made by SBB⁺. They were taken from a standard production lot and matched by SBB into face-to-face (DF) duplex sets with a very light preload. The only special provision was that they were lubricated for SBB tests with oil provided by BASD, to avoid potential lubricant incompatibility problems. The characteristics of these inch-series bearings were:

- SBB part number: 3TAR37-46 SUDF 3/5
- Ball and race material: 440C

*Ball Aerospace Systems Division (BASD), Boulder, Colorado.
+Split ball bearing (SBB).

- Separator material: Cotton cloth phenolic laminate
- Inside diameter: 58.74 mm (2.3125 in.)
- Outside diameter: 73.025 mm (2.875 in.)
- Number of balls 48
- Ball diameter: 3.18 mm (0.125 in.)
- Raceway conformities: 0.52-0.528 (inner and outer)
- Contact angle: 18-25 deg
- Raceway surface finish: $\leq 0.05 \mu\text{m}$ (2 $\mu\text{in.}$) AA
- Ball grade: 5
- ABEC tolerance class: 7T (SBB Super Ultra)
- Preload: 13.3-22.2N (3-5 lb)

Bearing sets were installed in the test cartridges shown in Figure 1. As the hub and housing were dimensioned, inner ring fits varied from line-to-line to 0.0125 mm (0.5 mil) loose; outer rings varied from 0.0025 to 0.015 mm (0.1 to 0.6 mil) loose. Deliberate gaps at the flanges of the inner and outer race clamp plates were provided to assure positive clamping. As shown in Figure 1, contact surfaces between the plates and bearing rings were located behind the raceway grooves to minimize race distortion from clamping force. The bearing mounts were made of cold rolled steel and were electroless nickel plated, except for the bearing mounting diameters. These diameters were specified for 0.4 μm (16 $\mu\text{in.}$) surface finishes.

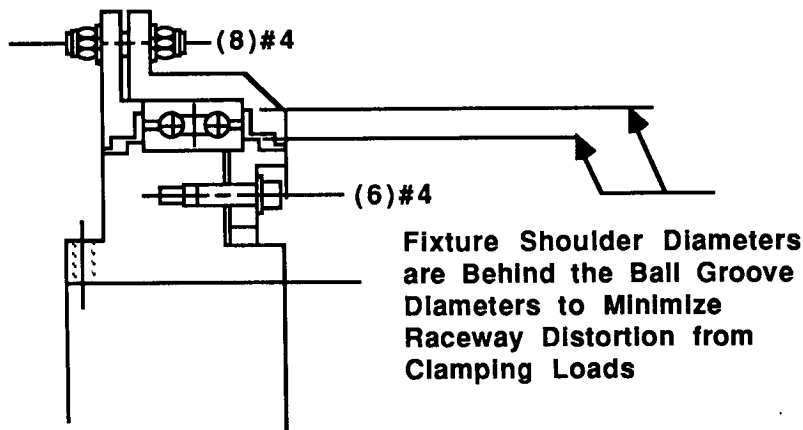

A/N 8505/MD76.8

Figure 1. Life test bearing sets were mounted in steel cartridges with plates clamping the races.

Figure 2 shows the test assembly before installation in the vacuum chamber. The five test cartridges were mounted on a single 25.4 mm steel shaft suspended top and bottom on Bendix flexures. The shaft was oscillated by a lever which was driven by a small bearing. This bearing was on an eccentric so that ± 0.3 deg (0.6 deg total) of test cartridge oscillation occurred with each rotation of the eccentric shaft. The eccentric shaft was mounted on dry-lubed ball bearings inside the vacuum chamber and driven from outside with a magnetic feedthrough.

ORIGINAL PAGE IS
OF POOR QUALITY

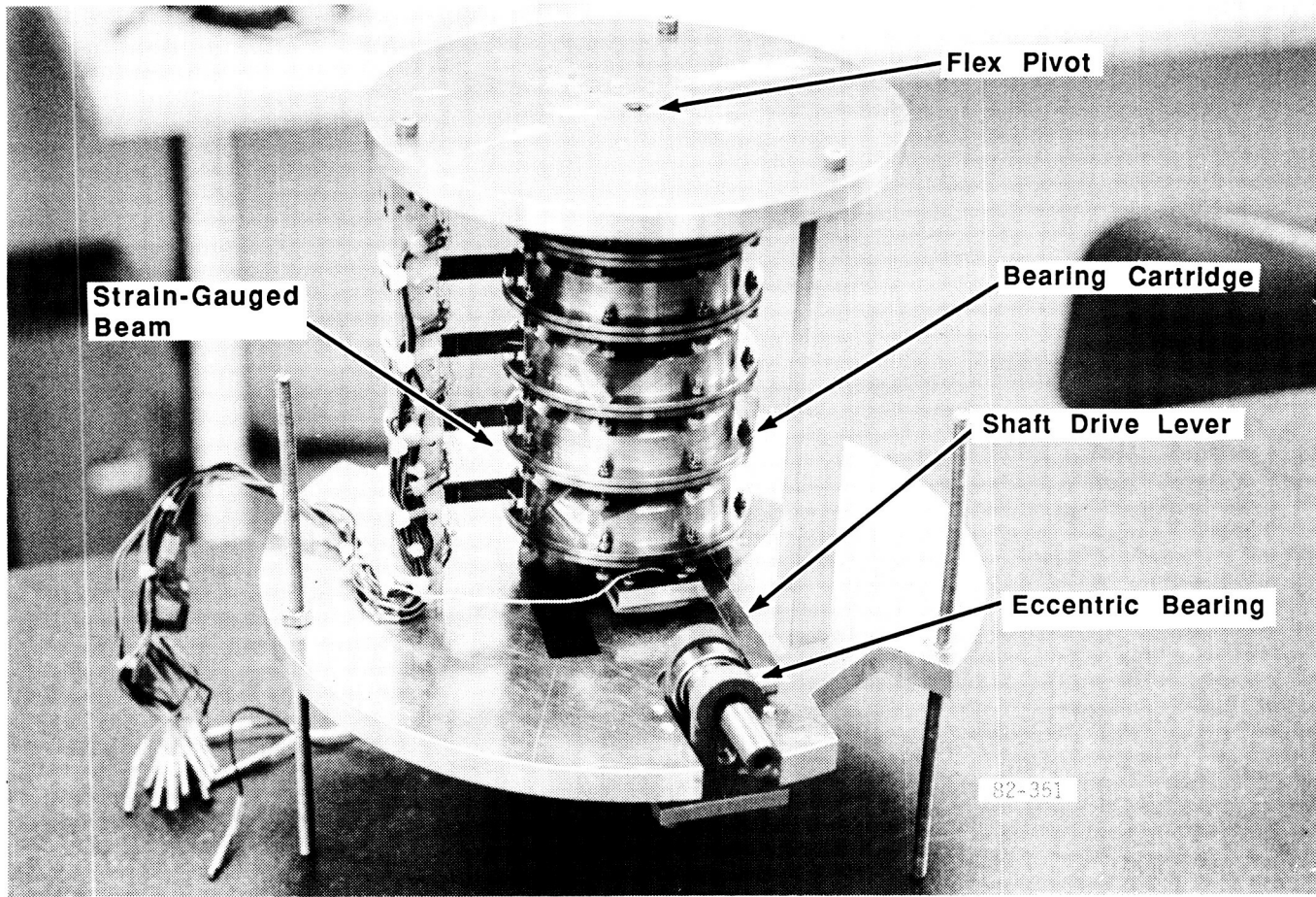

Figure 2. Five life test cartridges were mounted on a common shaft, oscillated by a lever and bearing on an eccentric. Strain-gauged beams measured bearing torque.

Test bearing torque was determined by strain gauged steel cantilever beams, which gave a torque sensitivity of 0.007N (0.025 oz-in.) or better. Angular displacement was measured with a Spectrol conductive film potentiometer.

During the test, torques were read out daily on a strip chart recorder. From time to time during the first 14 weeks, hysteresis (torque vs. displacement) plots were made with an X-Y plotter.

TEST ACCELERATION RATIONALE

Our goal was to simulate six years of operation at six cycles/min in a year or less, without introducing effects that would invalidate results. With dry lubricants, bearing life tests are sometimes accelerated because lubricant effectiveness is not considered speed-dependent over a moderate speed range. With liquid lubricants, however, formation of elastohydrodynamic (EHD) oil films at the contact spots may have a major effect on performance and the thickness of this film (h) varies with speed. Since h also varies with viscosity, and viscosity can be controlled by temperature, a mechanism exists for maintaining h while raising the test speed; however, then all other lubricant properties (such as evaporation rate) must be adequately accounted for if the test is to remain valid.

To determine the effectiveness of an EHD film, h is divided by the composite surface roughness (σ) of the balls and raceways to produce film parameter λ . If $\lambda \geq 2$, negligible asperity contact occurs, and bearing lifetimes predicted from standard bearing life test data can be expected. As h gets thinner, asperity contact increases, the bearing enters the boundary lubrication regime, and life reduction occurs. In our case, λ was only 0.002 using an h based on the average speed. This was so deep into the boundary lube regime (our nearest tests had been at $\lambda=0.03$) that we felt it would be satisfactory to double the speed after producing an otherwise dynamically similar accelerated test.

The life test was designed to simulate the following assumed, real-time temperature profile:

<u>Temp (°C)</u>	<u>Operating Time (yr)</u>
5	0.5
15	1.5
25	3.0
35	1.5
40	0.5

Lubricant loss, which is evaporation-rate dependent, was then calculated, and the single constant temperature that would produce the same loss was determined to be 30°C. Random temperature distribution with time was assumed in the absence of a defined mission temperature profile. Because fractionation of the lubricant causes a large reduction in the evaporation rate as lighter fractions evaporate, the amount of lubricant escaping depends on the temperature profile.

Next, a test temperature was calculated to give a lubricant viscosity that would theoretically result in the same bearing wear. Assuming that wear is inversely proportional to h (Note 1), it was calculated that 26°C would produce this viscosity. Under this assumption, a number of wear cycles at 26°C would cause as much wear as the same cycles distributed over the temperatures and times given above. This temperature was adopted as the baseline for the test.

Considering only EHD film theory of bearing lubrication, we could now accelerate the cycling rate as much as desired by reducing viscosity (raising temperature) so that the product of speed and viscosity remained constant. By going too far with this, however, lubricant evaporation would exceed our normal design limit (10 percent). This would cause abnormally high viscosity (viscosity increases as evaporation proceeds) that might skew test results. The following table shows the results of the calculations of allowable speed increase with temperature and the associated lubricant loss in the accelerated test period.

NOTE 1. This was a pure assumption. Data presented by Winer and Sanborn¹ show that under boundary conditions (film-thickness-to-surface-roughness ratio (λ) of 0.33), more than one-half of the contact load is still carried by the lubricant film. However, in this application with an average speed of 0.02 rpm at 26°C, our calculations using 36234011 indicated a λ of only 0.002. While we had run tests in the range of $\lambda=0.03$, no data existed in the range of this test.

Lubricant Evaporative Loss During Test

Baseline: 26°C, Viscosity = 101 c.s.

<u>Temp (°C)</u>	<u>Viscosity (c.s.)</u>	<u>Permitted Speed Increase to Keep Same Film</u>	<u>Lubricant Loss, Percent of Initial 0.1g</u>
26	101	1.0X	4.9
40	52	1.9X	7.8
50	36	2.8X	10.4
60	25	4.0X	13.9
70	18	5.6X	18.2
30	(equivalent orbit temp for comparison)		6.1

With a 10-percent limit on lube loss, 50°C became the nominal test temperature. The corresponding acceleration factor of 2.8x, however, resulted in a 2.1-year test, which was too long. It was therefore decided to accelerate the cycling rate further by a factor of 2.5. This would increase λ from 0.002 to slightly less than 0.004, a vanishingly small value from the standpoint of normal EHD film theory, which we felt would not affect the results. We then had test conditions of 50°C and 42 cycles/min, and six years of orbit operation would be simulated in 8.6 months. Because of the shorter test time, evaporative loss would be reduced to nearly the baseline estimate of 4.9 percent. Finally, the rule of thumb for chemical processes (rate doubling for a 10°C increase in temperature) would indicate rough equivalency between the eight months at 50°C and six years at 26°C.

In addition to the testing at 50°C, occasional short tests at 25°C and 5°C were scheduled to assure that lower temperature torques were acceptable.

TEST RESULTS

When the life test was started, torques quickly became erratic and increased severalfold over starting values, which were in the 0.0035 Nm (0.5 oz-in.) range. Two bearing pairs, Sets 1 and 2, developed especially high torques. After 151 hours, the test was interrupted and all bearings were disassembled, recleaned, and relubricated. At this time, the phenolic separators in Sets 1 and 2 were replaced with Teflon toroids. To make room for the toroids, 18 of the 48 balls were removed from each bearing. When the test cartridges were assembled, 5.3N (1.2 lb) springs were installed under the clamp screws because it had been found during initial assembly that bearing torques were extremely sensitive to clamp screw torque.

The bearings were then subjected to a test that lasted 39.5 weeks. Figure 3 shows the torque behavior of the five bearing pairs during this 39.5-week test. Torque is the peak-to-peak amplitude during a representative oscillating cycle of ± 0.3 deg. Bearing sets 3 and 4 behaved properly throughout the test and ran at approximately .0035 Nm (0.5 oz-in.) or less. Set 5 torque gradually climbed away from its low limit each time the setup was opened and restarted, finally finishing with a 4x increase. Sets 1 and 2 quickly developed very high torques. Torque increases in Sets 1, 2, and 5 were eventually attributed to blocking. Blocking occurs if some of the bearing balls jam into the ends of the separator pockets as a result of creeping away from their centered positions. Reference 2 contains a more complete discussion of this phenomenon, as well as recommendations for preventing it. Coincidentally, Reference 2 was issued the same month (May 1981) the 39.5-week test started, and was a great help to us in understanding the results.

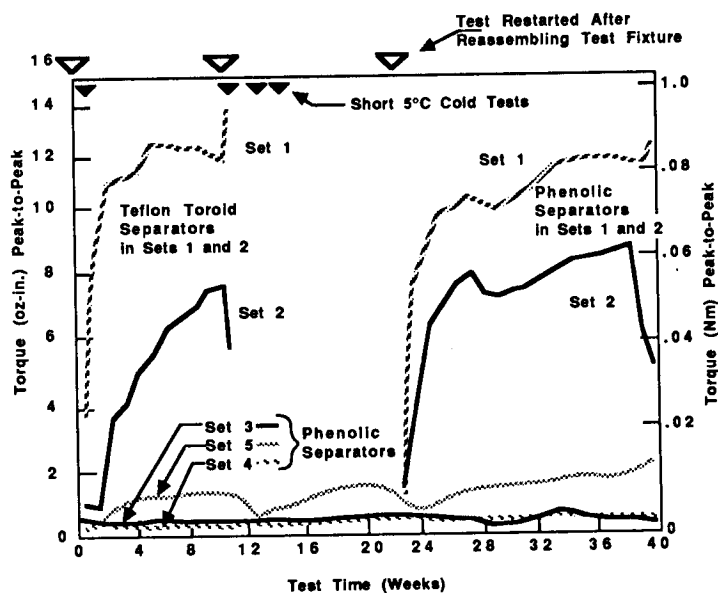

Figure 3. Two bearing sets were perfect through the entire 39.5-week test. The other three developed blocking.

The 39.5-week test was interrupted twice for Sets 1 and 2. These bearings were taken out in the tenth week and examined with great care. Neither lubricant degradation nor contaminant buildups could be detected. They were cleaned, rebuilt with phenolic separators, relubed, and returned to testing in the 23rd week. Their performance repeated almost exactly that obtained with Teflon separators. Later in this paper, we discuss our analysis of one of these bearing sets and the corrective action taken.

Bearing Set 3 showed excellent performance during the 39.5-week test. Let us look at it further.

When the fixture was first operated in the vacuum chamber, all bearing sets showed increasing torque with time. At 151 hours, the test was interrupted with set 3 showing the highly irregular hysteresis loop of Figure 4. This loop was drawn using an X-Y plotter with shaft position (potentiometer output) on the X-axis and torque on the Y. When the outer race was rotated just enough to relocate the ball contacts away from their initial position, the regular and low-torque upper loop of Figure 4 was produced.

No raceway degradation was visible when the bearings were inspected, but visual and SEM* observations showed thin surface films of unknown material. When the bearings were cleaned, significant particulate contamination was present in the rinses. A more thorough cleaning process was then implemented, and the bearings were relubricated.

Figure 5 shows a hysteresis loop from Set 3 when the test was restarted, and one of the last loops taken 12 weeks later. Torques are low and quite smooth. Although no other hysteresis loops were taken during the last 22 weeks of the test, it is safe to infer from the low constant torque for Set 3 (shown in Figure 3) that loops at the end of the test would have been similar.

*Scanning Electron Microscope

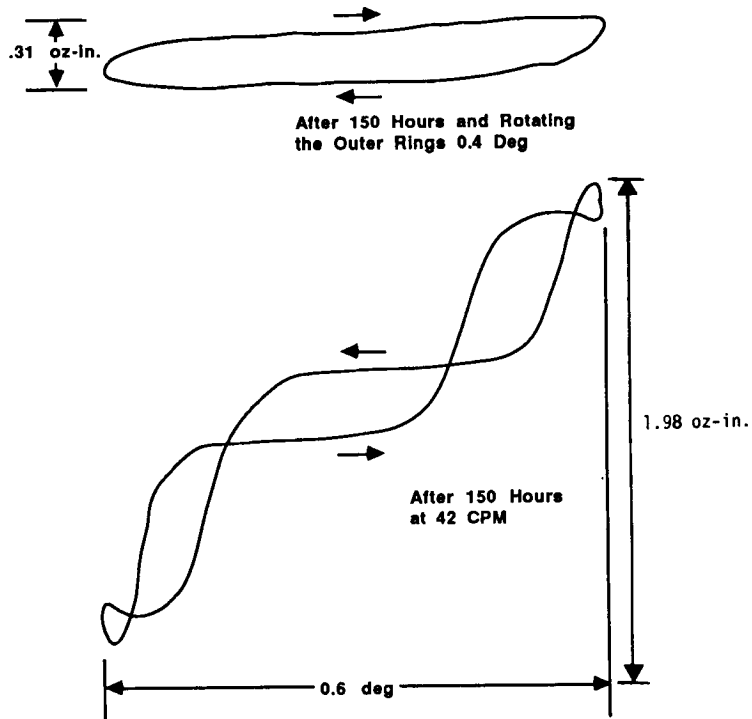

Figure 4. After 150 hours, Set 3 had developed a high, irregular torque that was corrected by moving ball contacts to new locations on the raceways.

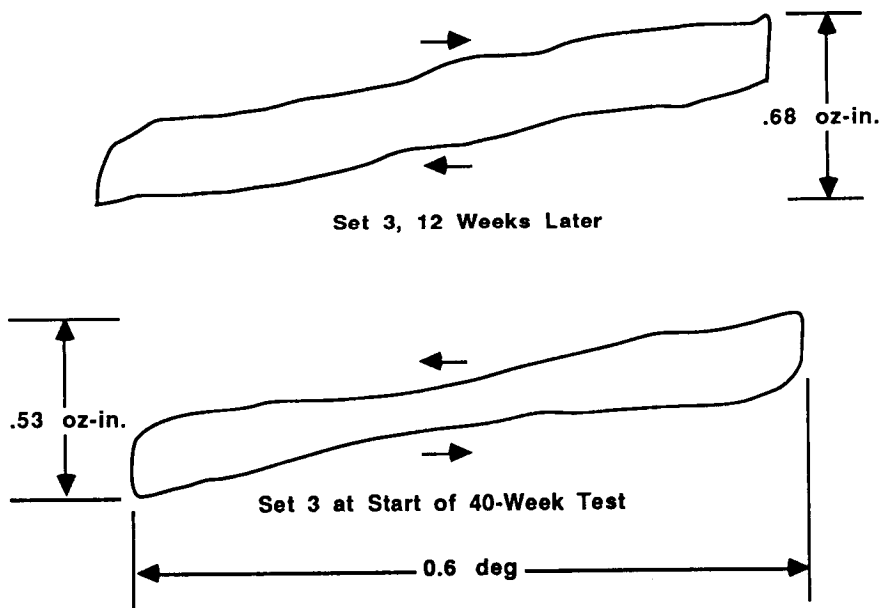

Figure 5. After cleaning, Set 3 shows smooth hysteresis loops when the 39.5-week test started, and 12 weeks later.

Hysteresis loops from the other excellent bearings of Set 4 were very similar to those for Set 3. These results show the importance of thoroughly cleaning critical bearings, as well as the ability of properly lubricated and installed duplex bearing sets to operate in low-speed, narrow-angle oscillations in the same place for 16 million cycles. The value of hysteresis in revealing problems is also shown.

Set 5, which also ran the full test but at up to 4x the torque of the good sets, displayed irregular hysteresis loops (Figure 6). A Set 4 loop taken the same day is shown for comparison. The reason for the difference was never determined. No hysteresis loops were made for Sets 1 and 2 during the 39.5-week test.

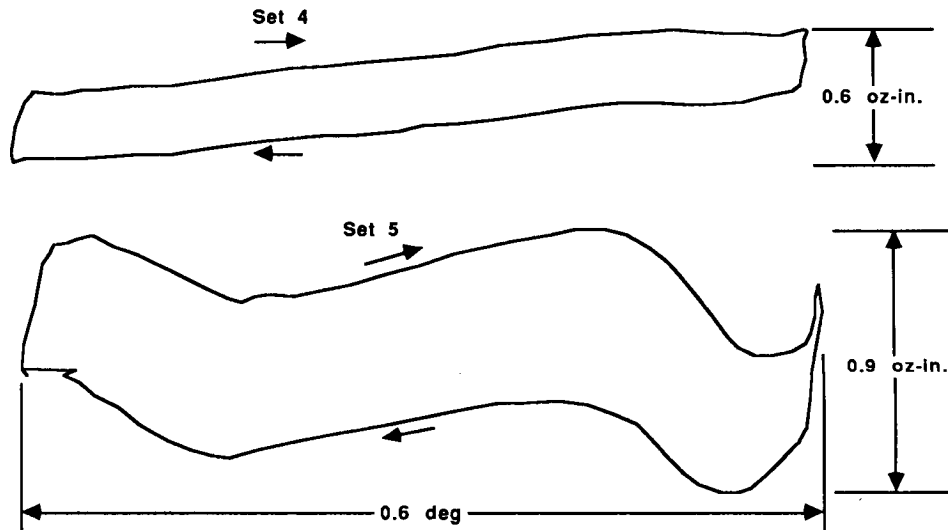

Figure 6. After 12 weeks, Set 5, which had higher torque during most of the test, shows an irregular hysteresis loop, while Set 4 is very smooth.

At the end of the test, a new drive shaft with an eccentric for ± 1 -deg oscillation was installed without moving the test cartridges from their 16 million cycle positions. The idea was to determine whether any ridges had formed at the limits of travel. Sets 3 and 5 were smooth crossing the ends of the ± 0.3 -deg tracks and had peak torques (at ± 1 deg) of 0.0049 and 0.0064 Nm (0.7 and 0.9 oz-in.). Set 1 showed anomalies inside and outside the ± 0.3 -deg track but indicated no ridges. It was concluded that no detectable wear scars had been formed and no debris had accumulated at the track ends.

INVESTIGATION OF BEARING SET 1

Bearing Set 1 did not run properly during any part of the 29 weeks it was tested, either with Teflon toroid separators or with the original phenolic ones. Behavior with the two separator types was essentially the same. Sets 1 and 3 were subjected to a thorough post-test inspection to discover any differences, and Set 1 was subjected to further tests to confirm the findings.

Visually, the bearings were in excellent condition, with a large oil meniscus at each ball/race contact. Infrared spectra of oil from both bearings showed no changes from the original oil. Small amounts of contaminants were visibly present and

showed up on the rinse filters, but the quantity was judged to be in the irreducible minimum range.

One bearing from each set was inspected under a microscope. The Set 1 bearing had barely visible rectangular spots on the races at some ball contact points; the Set 3 bearing did not show these spots. Both bearings from these two sets were then returned to SBB for inspection, which led to the following:

- All characteristics described in the Description of Test Apparatus section were confirmed except preload on Set 1, for which it was 162N instead of 13.3 to 22.2N, when the outer races were just brought in contact.
- The Set 1 bearings had 18 balls interchanged between the two bearings, one of which had balls that were 0.0762 mm (0.0003 in.) larger than those of the other.

This ball interchange occurred inadvertently at BASD when the Teflon toroids were replaced with the phenolic ones. It had been necessary to remove 18 balls from each bearing when the toroids were installed. If the outer races of the Set 1 bearings had been firmly clamped, the high preload would have resulted in a several-fold torque increase. However, the springs under the clamp screws limited preload to about 40N. At SBB, when the balls were restored to their proper bearings, preload dropped to 22N. Profilometer measurements on the raceways, with a sensitivity of .25 μm across the ball contact zones and away from them, showed no detectable differences for the visible contact spots. (These spots may have been caused by the oversized balls, which would have carried the full preload, or by a few balls which were found to be slightly outside sphericity limits for Grade 5.) In short, except for the assembly error at BASD, all four bearings were essentially perfect according to original requirements.

The mounting fixtures for Sets 1 and 3 were also inspected by SBB. Roundnesses of the bearing mounting surfaces were within 0.0025 mm, but surface finishes appeared to exceed the drawing limit of 0.4 μm .

The important finding was that the bearings in Set 1 were tight fits in their fixture instead of slip fits. This suggested that improper seating could have occurred, followed by the blocking phenomenon described by M.J. Todd (Reference 2). We do not know how the misassembled balls were spaced; however, if the 18 bigger balls in one bearing were adjacent to each other and not spaced around somewhat uniformly, then the condition for race misalignment and blocking would have been built into the bearings themselves.

The Set 1 bearing fixtures were reworked by lathe polishing until inner and outer bearing rings could be assembled with less than 9N of force (approximately 0.0025 mm loose fits). The bearings were cleaned and relubed, and then installed in the fixtures without springs under the clamp screws. The effect of clamp screw tightening torque on bearing torque was then evaluated at up to 0.45 Nm. Bearing torque remained constant, increasing at 0.7 Nm with lockup at 0.9. In spite of having the clamp surfaces behind the raceway grooves, excessive clamping loads (approximately 45N per bolt at 0.7 Nm bolt torque) produced detrimental race distortion.

The Set 1 bearings were then tested in air for 57 days (3.5 million cycles) with clamp screws torqued to 0.45 Nm, followed by a 30-day test with the 5.3N springs under the screw heads. The springs had been inserted one bolt at a time without

disturbing or rotating the bearings. Figure 7 shows the torques during these two tests as well as the torque for 51 days of the original test with phenolic separators (from Figure 3). Opening up the race fits caused the maximum torque to drop from 0.06 to 0.014 Nm with the solid preload, but a two-fold increase with operation still occurred. Soft preloading restored the initial 0.007 Nm torque level that existed at the start of the solid preload test, and this torque was essentially constant for 1.8 million cycles.

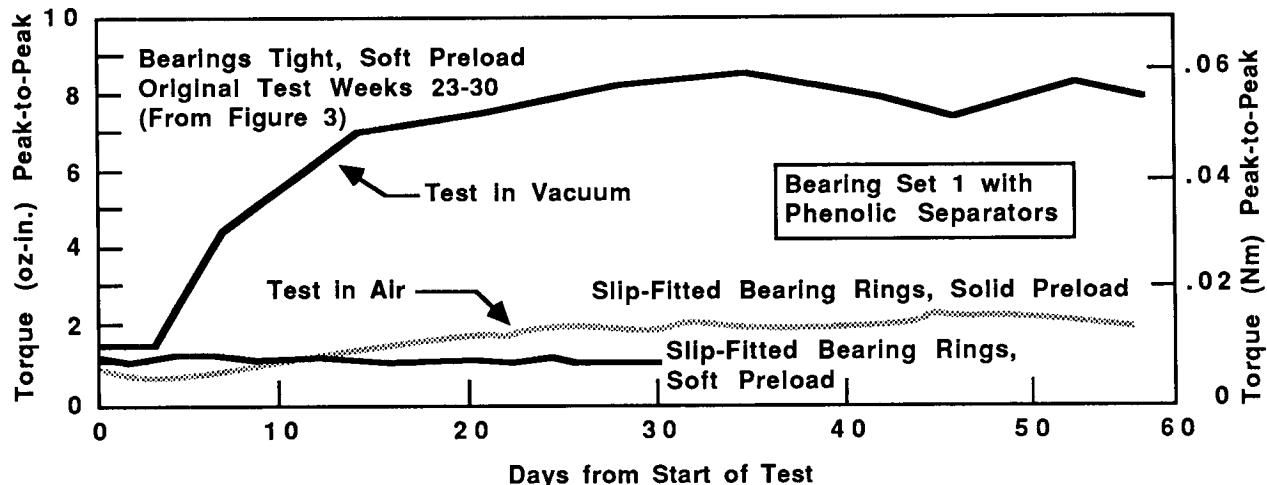

Figure 7. When Set 1 bearings were made slightly loose in their test fixture, torque dropped to 0.007 Nm (1 oz-in.) and was constant for 30 days. With solid preload and slipfits, torque increased from 0.007 to 0.014 Nm in 25 days and then stabilized.

The post-test effort showed the value of mounting the bearing rings in duplex sets with slightly loose fits, as well as the benefits of "soft" preloading. We did not discover why Set 1 torque was about twice the level achieved on Sets 3 and 4.

TEST CONCLUSIONS

The following conclusions were drawn from this test program:

- When properly made and installed, lightly preloaded duplex bearings having phenolic laminate separators and lubricated with thin films of BASD 36234 liquid lubricant can withstand more than 16 million low-angle oscillating cycles without any signs of degradation whatsoever and without significant torque variation.
- Blocking can occur in oscillating duplex bearings at even extremely narrow angles of motion.
- Races should be slip fits, if possible, to assure proper performance and prevent blocking.
- Soft (spring) preloading is better than hard preloading if bearing torque is critical. This confirms a Reference 1 recommendation.
- Bearings must be scrupulously clean.

As a result of these findings, we decided to follow the recommendation of Reference 1 to use more open raceway conformities in the actual gimbal bearings, and to use soft preloading. (As will be seen, soft preloading had to be abandoned.)

GIMBAL BEARING INSTALLATION

The original concept for mounting the inner axis duplex pair bearings is shown in Figure 8. Belleville washers were used to provide a soft preload. This design was abandoned when it was determined that the bearing outer ring fits could not be loose (in order to meet axis perpendicularity specifications). Slip fits are necessary for the Belleville to be able to restore the bearings to the preloaded condition after vibration.

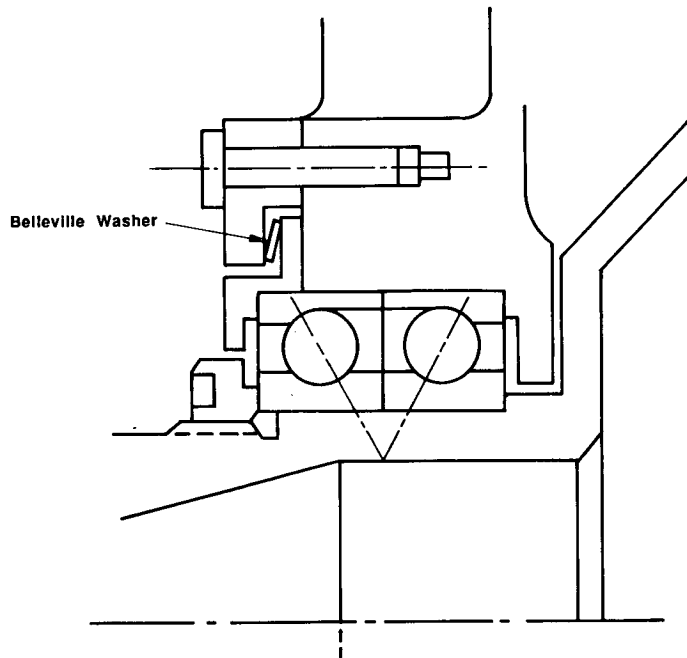

Figure 8. The initial gimbal design used Belleville washers to provide soft preload on its duplex bearings.

The final configuration for inner axis driveline components is shown in Figure 9. A payload mass-simulator connects the two shaft hubs during BASD tests. The bearing seats are match-machined to each bearing pair to provide a 0.0025 mm slip to 0.0025 mm press fit on the diameter. This close fit is not ideal from the blocking standpoint, but was felt to be the best possible compromise. The gap between the outer race retaining ring and housing is shimmed to 0.025 mm maximum when the bearing outer races are just brought into contact with each other, making clamping force on the races independent of torque on the clamping screws. We experienced no problems with bearing race distortion by the large nuts used as inner race retainers. The bearings are ABEC 7 with nominal raceway conformities of 0.549 outer and 0.528 inner. Outer race conformity is more open than usual, in keeping with a life test conclusion. The shafts, diaphragm, and yoke are titanium 6AL-4V. Bearings are lubricated with BASD 36234 oil, which has such a low outgassing rate that reservoirs are not required when closures, as shown with barrier film, are provided.

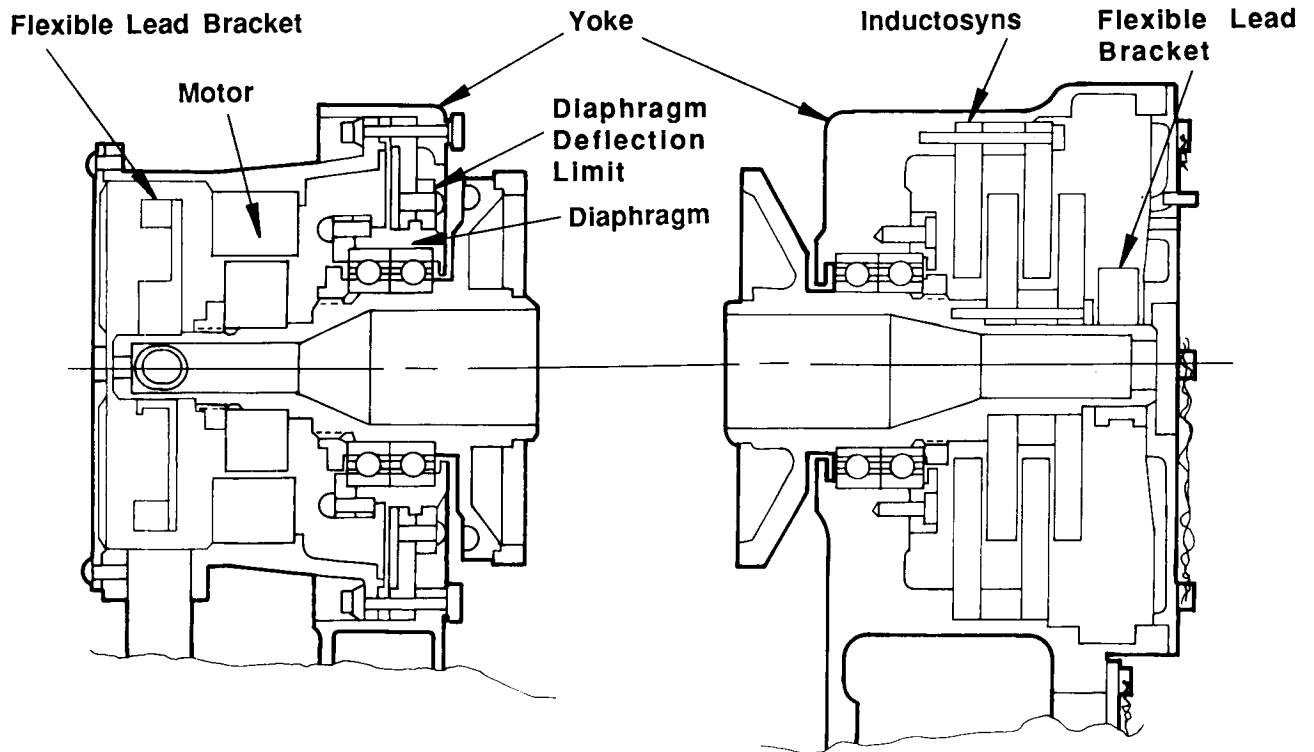

Figure 9. Final configuration of inner axis driveline components. Soft preloading of the duplex bearings could not be used.

The inner axis has a rotation range of 31 deg, but its normal mode is narrow-angle oscillation in one location. Spring-loaded stops are installed at each end of the travel range.

EXPERIENCE WITH GIMBAL BEARINGS

Inner axis drag torque is measured as a part of gimbal acceptance testing. The axis is rotated at a constant speed (approximately 30 deg/min) by an external motor. Torque is measured with a torque transducer, producing the typical trace shown in Figure 10. The top trace indicates rotation from the +30.5 deg stop to the -0.5 deg stop. At end-of-travel, the axis is driven into the stop slightly, compressing the stop spring, to assure complete travel. The lower trace shows rotation in the opposite direction, again reading left to right. The slope in the traces is caused by spring torque of the flexible electrical leads at both ends of the axis. These leads are wound in opposition to each other, and their torques cancel in the middle of the travel range.

Four of the six gimbal assemblies tested had torque traces similar to those shown in Figure 10. Two assemblies exhibited traces as shown in Figure 11. Note the large spikes just inside the stop locations. Following is a summary of the investigation and analysis of this anomaly.

Extensive investigation of the test setup removed it from the list of possible causes. Blocking in the bearings was proposed next. To see if the spikes would grow, the axis was cycled stop-to-stop by hand, with torque traces taken after every 100 cycles. The spikes increased from 0.028 Nm to almost 0.35 Nm after 300 cycles, then stayed at the same level for 700 more cycles. Random movements within the stop

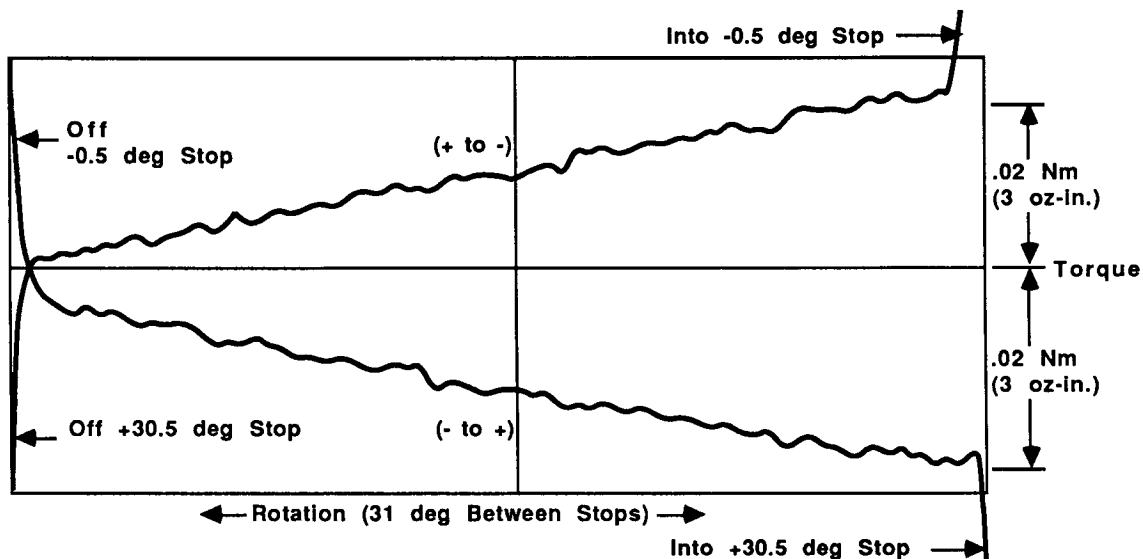

Figure 10. An acceptable inner axis torque trace. Only minor torque ripple is seen between stops.

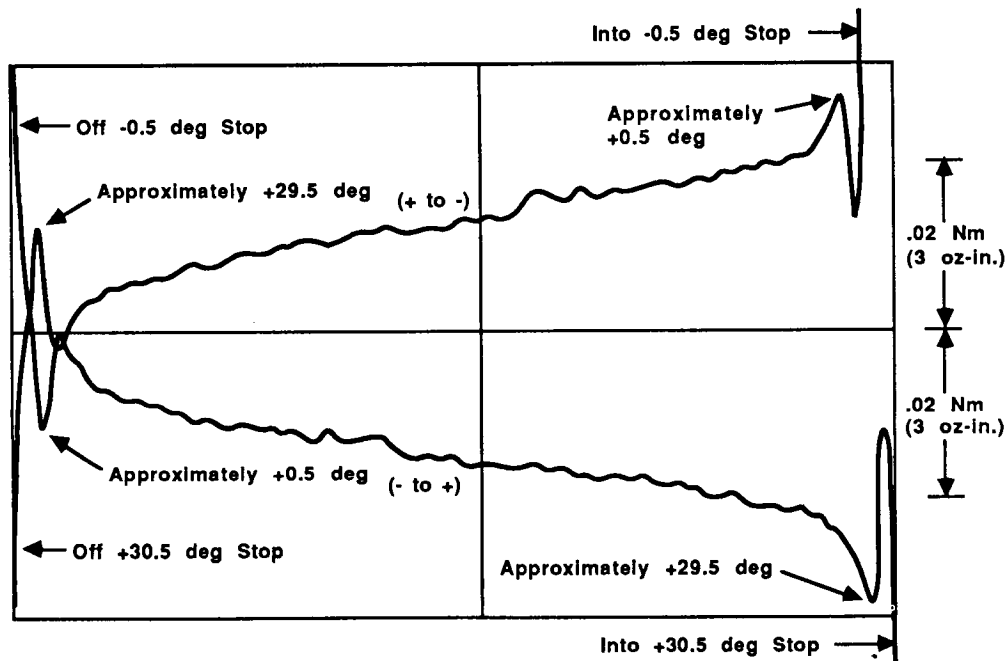

Figure 11. An unacceptable inner axis torque trace showing gross torque anomalies just inside the stops. These anomalies developed during several hundred step-to-step cycles.

range had no effect on the spikes. Neither of these pieces of data suggest blocking, nor does the large torque drop after the spike. Finally, the springs were removed from the stops to allow approximately 40 deg of travel, and the trace in

Figure 12 was taken. If this anomaly were blocking, the spikes should have disappeared after the first pass. Since the spikes were still present on the return part of the cycle, blocking was not the problem.

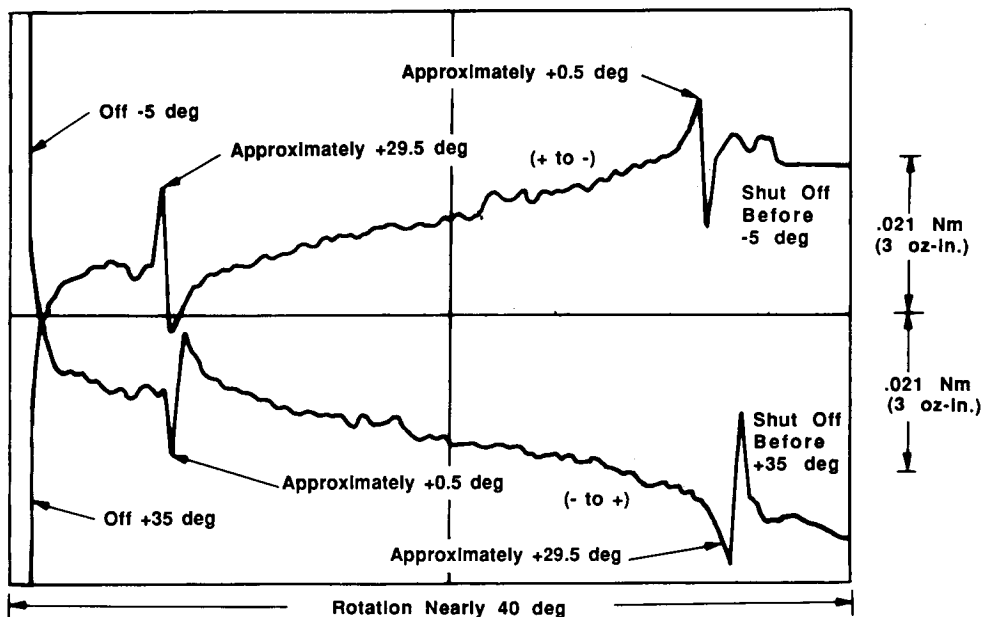

Figure 12. When the drive was rotated beyond the original travel limits, torque spikes remained in their previous locations.

At this point, the torque anomaly felt, by hand, rather like a magnetic detent. The mass simulator, the motor side flex cable and all wires, and the motor housing (including the motor stator) were removed to eliminate all possible hardware problems outside the bearings. A torque trace run on just the motor-side bearings still showed spikes. Two possible explanations were considered.

- There could be a defect or a problem with assembly that caused the race to pinch the balls.
- There could be debris piling up in small hills behind the balls, thereby causing the spike.

To explore the first possibility, the inner race retaining nut on the motor side bearings was removed and replaced finger tight. No change was evident in the torque trace. The outer race retaining ring was also loosened, again with no effect. Thus, debris became the prime suspect.

Assuming that debris caused the anomaly, it should be possible to produce spikes in other locations; therefore, blocks were attached to the second discrepant gimbal to limit travel to 24 deg. Initially, no spikes were present at the new stop locations; cycling block-to-block generated new ones. Traces taken after the 24-deg stops were removed show the new spikes and the original ones (Figure 13). The spikes remained after several stop-to-stop and random cycles. A trace taken after the gimbal sat overnight, to see if the debris hills would flow away, still showed all the spikes. Just to be positive, the travel was reduced to 21.7 deg and again

spikes were created. The blocks were removed as were the stop springs, to permit 40 deg of travel, and all six spikes were visible. Cycling at 40 deg did not generate any new spikes, however, and after 500 cycles the existing spikes were noticeably smaller. After 1000 cycles they were gone. Subsequent attempts to create spikes by shortening travel were unsuccessful.

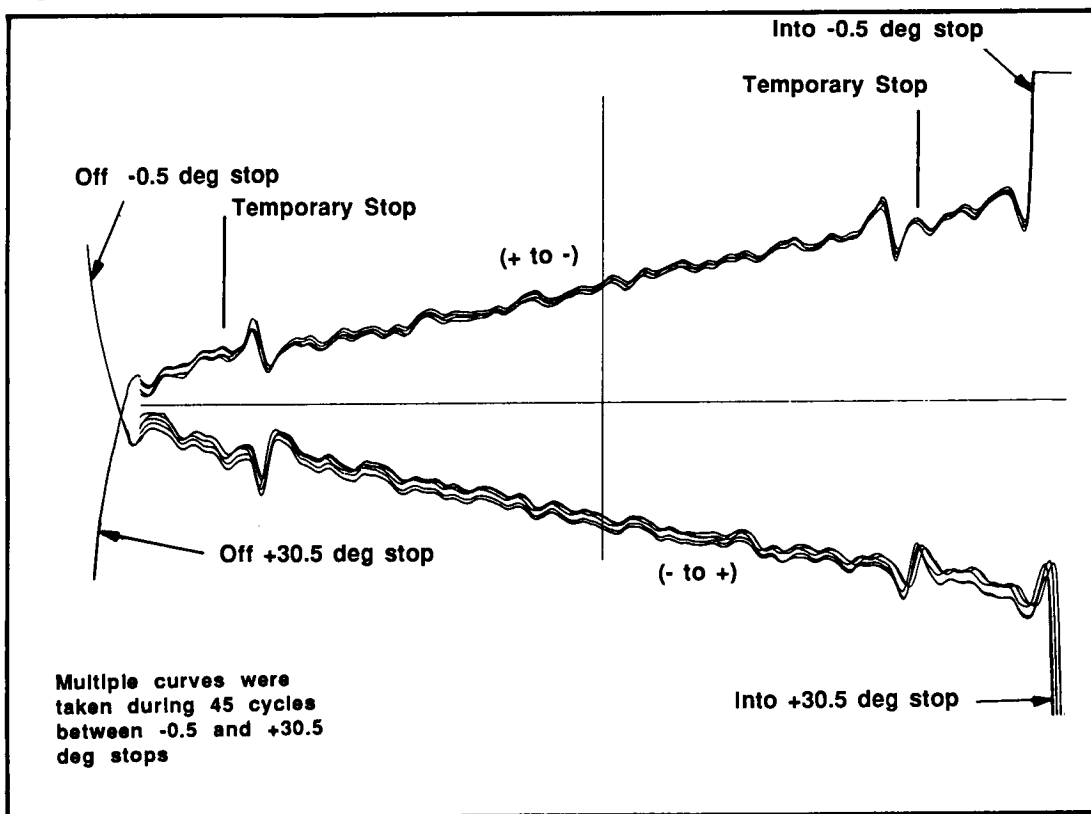

Figure 13. Cycling between temporary stops set inside the original travel limits produced new figure spikes which persisted for more than 45 cycles when the travel was increased again.

Analysis of the bearing geometry shows that with 31 deg of travel, the ball paths do not overlap; however, with 40 deg, ball paths do overlap. It was then evident that the torque spikes were caused by debris piling up just before the ends of the ball paths, under repeated cycling, at fixed angles too short to overlap the ball tracks.

While the mechanism for debris piling is not understood completely, the torque traces indicate that hills build up behind the balls at the end of their travel. Apparently, the hills are formed by compaction of debris just as ball motion begins and before a bow wave builds up that can carry any particles off to the side and back into the track again behind the ball.

Having established debris as the cause of the torque anomaly, it remained to find the source of the debris. At BASD, bearings are run-in, thoroughly cleaned and relubed, and then put in clean bags until assembly time. Assembly takes place in a clean room.

The bearings were removed from the unit, visually inspected, and cleaned. A particulate check on the cleaning rinses showed primarily many small aluminum particles. A much smaller amount of titanium was also present. A few dry-lube particles were

found, but not enough to cause a pile or thicken the wet lube. (The inner race retaining nut threads are dry lubed.) The separators did not show wear, nor were any separator particles found. Bearing raceways were neither pitted nor gouged, and there was no significant amount of iron in the rinse.

The aluminum particles present in the solvent rinses were thought to be the primary problem. The source of these particles, on the motor side, was most likely the aluminum tools used for assembly. These same tools were used on the Inductosyn side as well. In addition, the Inductosyns are basically aluminum plates which are pressed in at assembly. Other hardware pieces are aluminum, but they are not considered primary debris generators.

In summary, it was concluded that the torque anomalies experienced during testing were caused by small debris hills building up in the bearings. These hills could only build when the ball tracks did not overlap. Once the ball tracks overlapped, the debris was redistributed such that it could no longer build up when travel was shortened. The debris was generated during assembly by press fits of the hardware and the tools used for the installation.

As a result, several changes were instituted:

- Assembly procedures were modified to minimize debris producing operations inside the bearing cavities and to increase the number of vacuuming cycles.
- Aluminum assembly tools were changed to titanium because aluminum chips and flakes much more easily than titanium.
- The bearings are now run-in (360-deg rotation) overnight in the gimbal to distribute any assembly debris. This is in addition to the run-in they receive before assembly.
- Experience shows that the torque anomalies form within a few hundred cycles after assembly, if they are going to occur at all. Therefore, a test consisting of 1000 stop-to-stop cycles has been added to the acceptance testing. Although the oscillating life test showed that as many as a million narrow angle cycles might be necessary to produce blocking, we believe that the 1000 wide-angle cycles will probably also reveal any blocking tendency that may be present.

ACKNOWLEDGMENTS

G.H. Ahlborn of BASD developed the rationale and established parameters for the bearing life test. J.T. Hinricks was the responsible engineer during the test and wrote the comprehensive final report from which material herein has been extracted. Several BASD engineers, including R.B. Stocker, L.E. Oystol, D.A. Paschal, and D.A. Payne, contributed to the final gimbal design for which one of the authors, C.L. Pollard, became responsible during the production phase. D.D. Phinney designed the bearing test rig.

REFERENCES

1. W.O. Winer and D.M. Sanborn: Surface Temperatures and Glossy State Investigations in Tribology. NASA Contractor Rpt. 3031 on NSG Grant 3160, June 1987.
2. M.J. Todd: Investigation of Torque Anomaly in Oscillating PDM Bearings. ESA (ESTL) 49 European Space Tribology Laboratory, May 1981.