

1188-22388

# UNIFIED CONSTITUTIVE MODEL FOR SINGLE CRYSTAL DEFORMATION BEHAVIOR WITH APPLICATIONS

**K.P. Walker**      **Engineering Science Software, Inc. (Smithfield, RI)**  
**T.G. Meyer**      **Pratt & Whitney (East Hartford, CT)**  
**E.H. Jordan**      **University of Connecticut (Storrs, CT)**

Single crystal materials are being used extensively in gas turbine airfoils and are candidates for other hot section components because of their increased temperature capabilities and resistance to thermal fatigue. Under many operating conditions, the thermal and mechanical loads are sufficiently severe to cause inelastic material behavior. It is widely recognized that design of such components for long fatigue life requires an accurate assessment of that inelastic behavior. However, no convenient inelastic material models are currently available for structural analysis of these anisotropic components.

Development of such a constitutive model for single crystal material has been undertaken recently in two NASA sponsored programs: Life Prediction and Constitutive Models for Engine Hot Section Anisotropic Materials (NAS3-23939) and Biaxial Constitutive Equation Development for Single Crystals (NAG3-512). A slip system based constitutive model for single crystal materials is now in its final stages of development. The model has been fit to a large body of constitutive data for single crystal PWA 1480 material and will also be tested against data for a second single crystal material. The model uses a unified approach for computing total inelastic strains (creep plus plasticity) on crystallographic slip systems reproducing observed directional and strain rate effects as a natural consequence of the summed slip system quantities. The model includes several of the effects that have been reported to influence deformation in single crystal materials. These include the contributions from slip system stresses other than the Schmid shear stress, latent hardening due to simultaneous straining on all slip systems, and cross-slip from the octahedral to the cube slip systems. The model is operational in a commercial Finite Element code and is being installed in a Boundary Element Method code.

---

**Contract: NAS3-23939**

**Grant: NAG3-512**

**NASA LeRC Technical Monitors: Drs. G.R. Halford and R.L. Thompson**

# ADVANCES IN TURBINE AIRFOIL MATERIALS HAVE RESULTED IN HIGHER STRENGTH AND INCREASED DURABILITY

One of the more important recent developments in gas turbine blade materials has been the introduction of directionally solidified and single crystal castings. Among the advantages of these new materials is an increased creep and oxidation resistance which results from the elimination of grain boundaries. In addition, the elimination of grain boundary strengthening elements in single crystal material results in higher melting temperature and permits greater flexibility in achieving optimum heat treatments. The low elastic modulus in the growth direction also improves the fatigue life by reducing the thermally induced stresses.

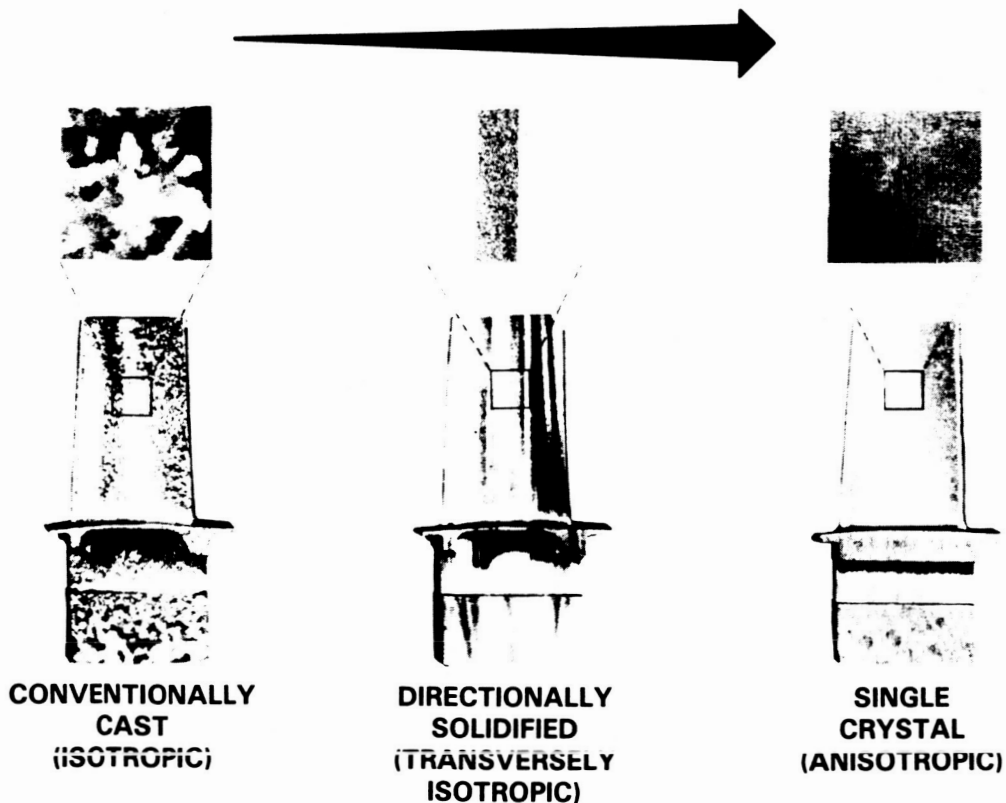

ORIGINAL PAGE IS  
OF POOR QUALITY

# NICKEL BASE SINGLE CRYSTAL SUPERALLOYS HAVE A FACE CENTERED CUBIC CRYSTALLINE STRUCTURE

The single crystal material being used in the current effort is PWA 1480. It is a two phase Nickel based superalloy having a Face Centered Cubic atomic arrangement in both the  $\gamma$  matrix (mostly Nickel) and the  $\gamma'$  strengthening phase. The cuboidal  $\gamma'$  is arranged in a regular array in the matrix material. It is well known that this material deforms by slip on specific crystallographic planes. This fact has been used in developing a constitutive model for PWA 1480.

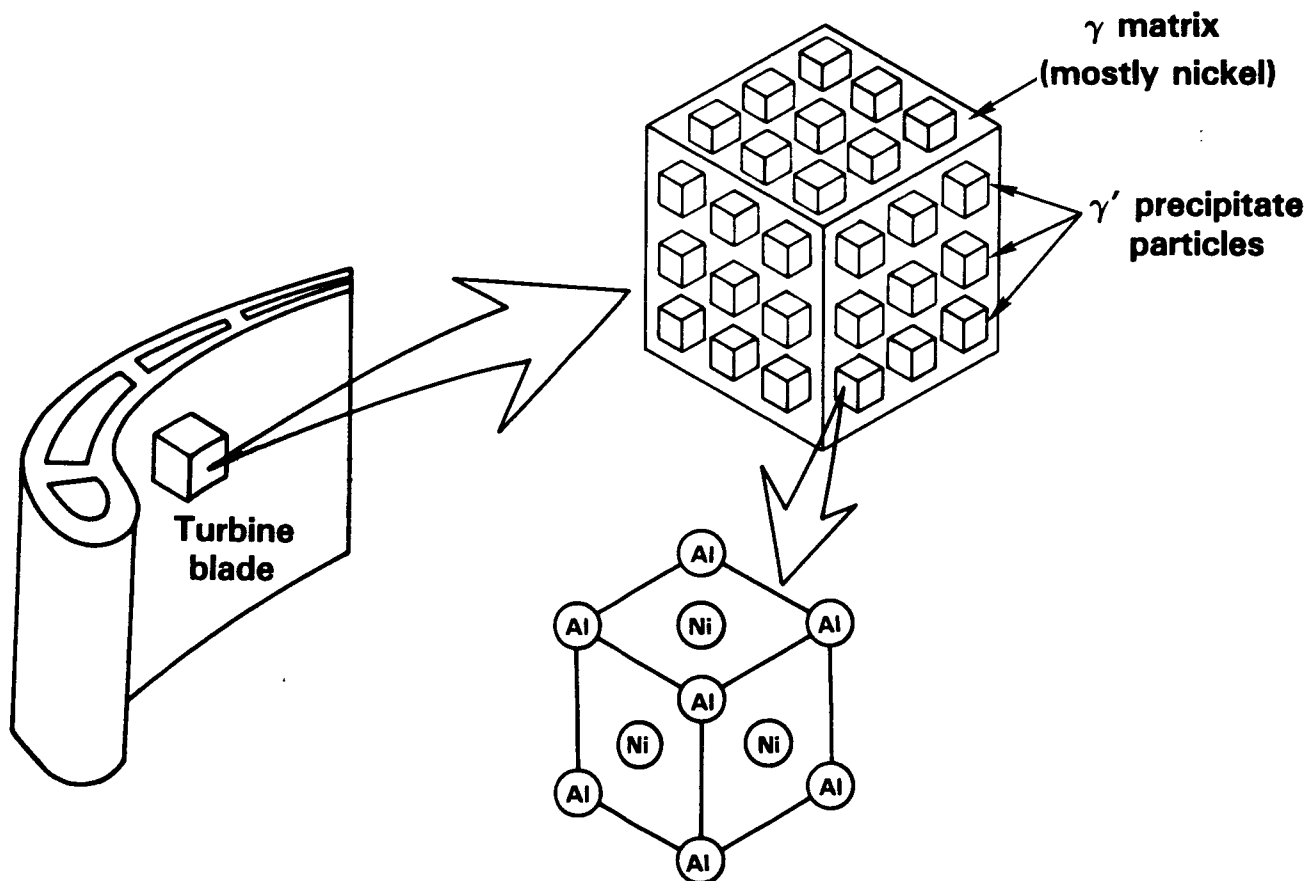

# SINGLE CRYSTAL COMPONENT PROPERTIES ARE HIGHLY DIRECTIONAL (ANISOTROPIC)

A key factor in the design and behavior of columnar grained and single crystal material is the variation of material properties with respect to the natural material axes. For example, in PWA 1480 at 1200F, Young's Modulus obtained from a tensile bar oriented along one of the material's cubic axes ( $\langle 001 \rangle$  Miller index) is approximately 15 Msi while the value in the cube diagonal direction ( $\langle 111 \rangle$  Miller index) is approximately 39 Msi.

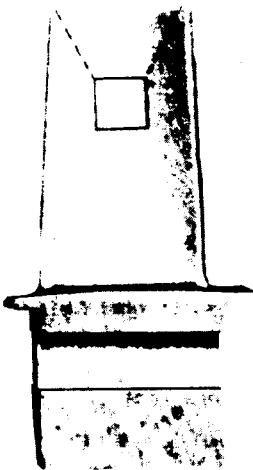

Single crystal

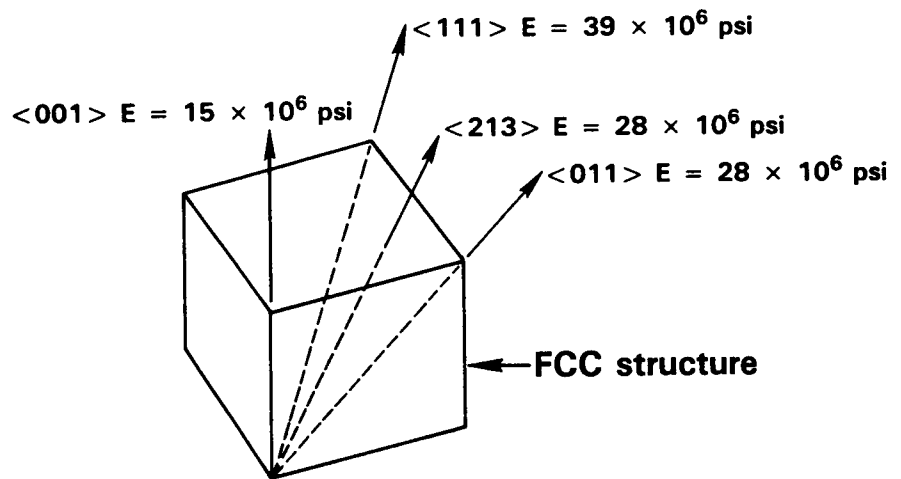

Young's modulus varies by almost a factor of 3 with direction

# CLASSICAL MODELS GIVE POOR PREDICTIONS OF YIELD STRESS VARIATION WITH ORIENTATION

While these elastic property variations are correctly predicted with most current structural analysis tools, the prediction of creep and plastic behavior, which is often required for durability assessment, is not easily accomplished. For example, the classical yield models of Lee & Zaverl (1978) and Hill (1948) would predict the yield stress to decrease continually from a maximum along the  $\langle 001 \rangle$  axis to a minimum along the  $\langle 111 \rangle$  direction. But experiment has shown that the yield strength has a minimum for an orientation in the middle of the stereographic projection. Furthermore, it is now recognized that the classical approach of separately calculating creep and plastic strains is difficult to apply in the structural analysis of components that operate in transient thermal and mechanical environments.

The constitutive model developed in the current effort attempts to incorporate metallurgical observations regarding the deformation of single crystals in a unified viscoplastic formulation. Inelastic strains (accounting for "plasticity" and "creep" simultaneously) are computed on crystallographic slip systems. The model thus achieves the required directional properties as a natural consequence of summing the slip system stresses and strains.

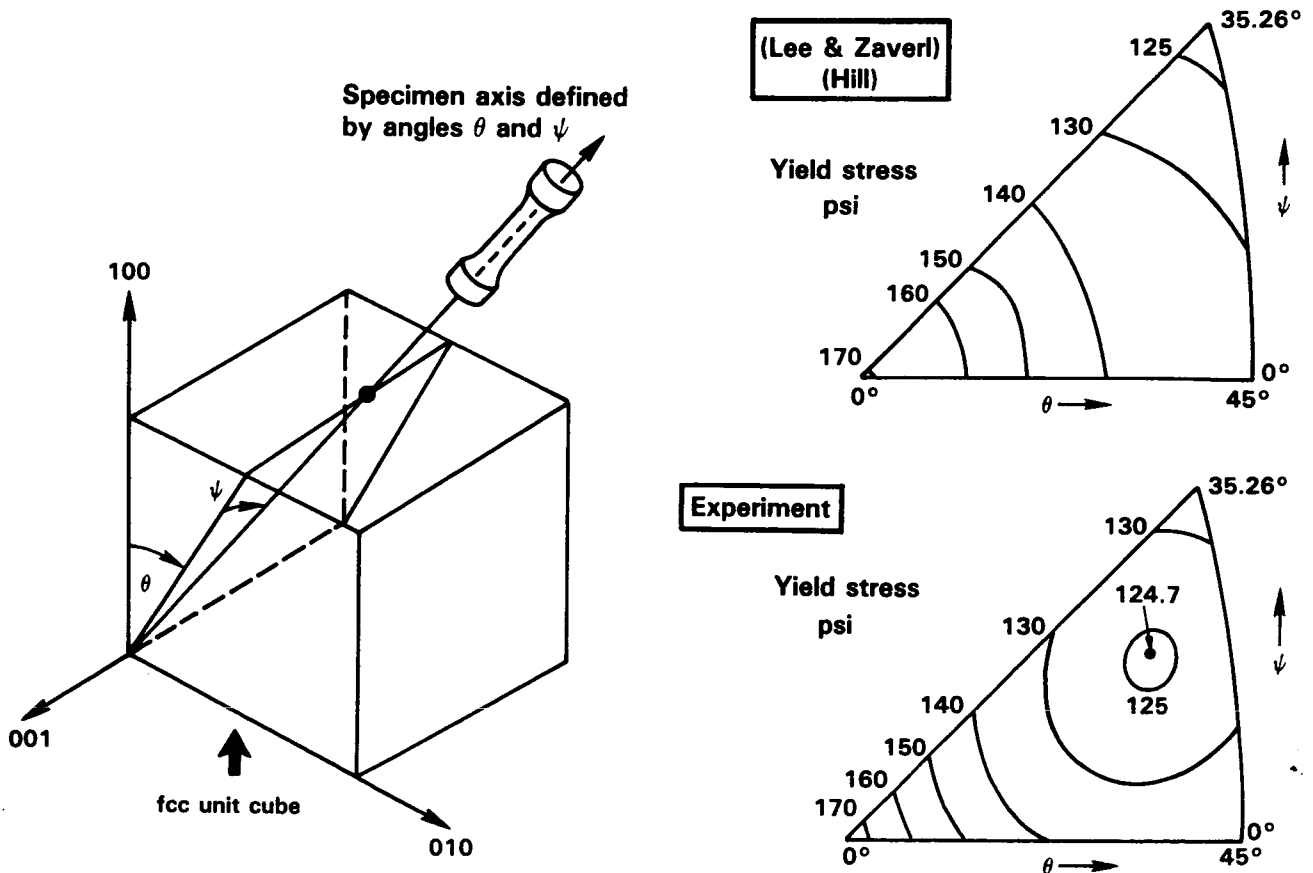

# CRYSTALLOGRAPHIC SLIP FORMULATION

The model has been formulated to use stresses and strains referred to any geometric or "global" coordinate system which may be convenient for the structural analysis of a component. As with any analysis involving an anisotropic material, the relative orientation of the global and material axes are also required. The model then transforms the global stresses and strains onto a crystal coordinate system. These crystal system quantities are subsequently resolved onto each of twelve octahedral and six cube slip systems. The Schmid shear stress on each system is used to calculate the inelastic shear stress on that system. Provision has been made in the model to include the effect of all six components of slip system stress.

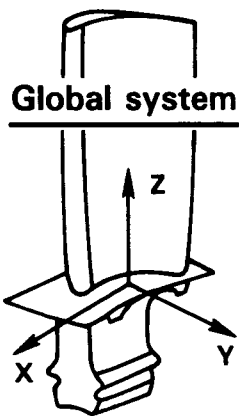

## Crystal system

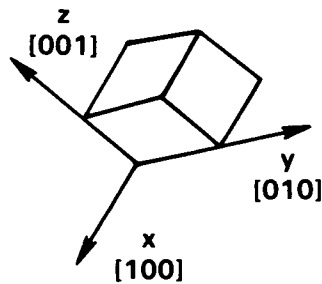

- Find stress in crystal system,  $x, y, z$

$$\begin{bmatrix} \sigma \\ \sim \end{bmatrix} = \begin{pmatrix} \sigma_{xx} & \sigma_{xy} & \sigma_{xz} \\ \sigma_{xy} & \sigma_{yy} & \sigma_{yz} \\ \sigma_{xz} & \sigma_{yz} & \sigma_{zz} \end{pmatrix}$$

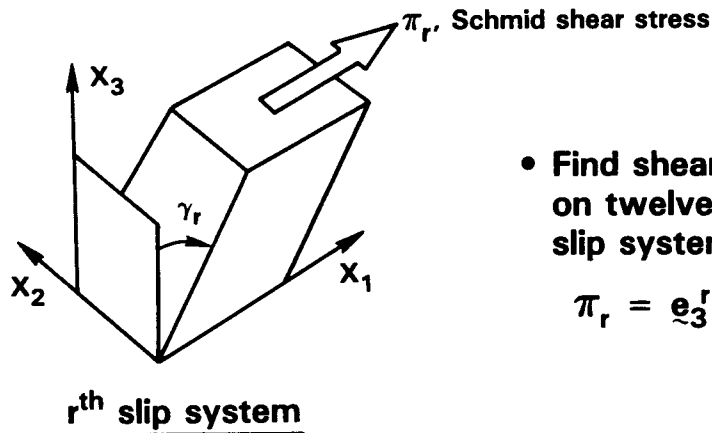
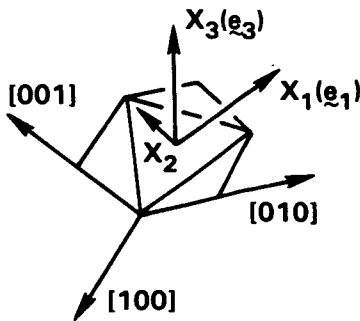

- Find shear stress on twelve octahedral slip system

$$\pi_r = \mathbf{e}_3^r \cdot \boldsymbol{\sigma} \cdot \mathbf{e}_1^r$$

# CRYSTALLOGRAPHIC SLIP FORMULATION

The general form of the equations governing the inelastic strain on each slip system is shown below. The form is the familiar viscoplastic equation employing two state variables (Walker 1981). The rate of change of the slip system inelastic shear strain is a function of the applied slip system shear stress, an internal back stress, and a drag stress. The back stress and the drag stress each evolve with inelastic strains. An inelastic shear strain rate is calculated in each slip system's coordinate axes and transformed to the common crystal coordinate system where they are summed to obtain a combined inelastic strain rate. Once this inelastic strain rate is known, the rate of change of stress is easily obtained using the known total strain rate and the stiffness matrix. Finally, the stress rate is transformed onto the global coordinate system.

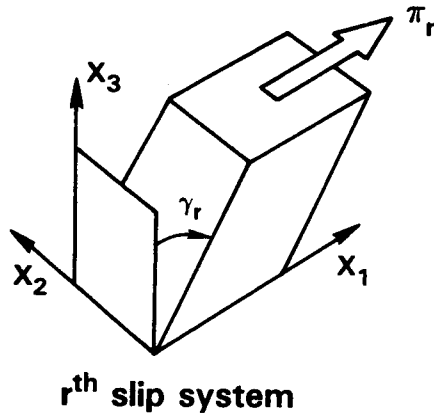

$$\dot{\gamma}_r = \left| \frac{\pi_r - \omega_r}{K_r} \right|^{p-1} \left( \frac{\pi_r - \omega_r}{K_r} \right)$$

↖ Equilibrium stress  
 ↗ Drag stress

⇒ Evolution equations for  $\dot{\omega}_r$  and  $K_r$

$$\dot{(\dot{\epsilon}_{ij}^p)}_r = \begin{pmatrix} 0 & 0 & \dot{\gamma}_r/2 \\ 0 & 0 & 0 \\ \dot{\gamma}_r/2 & 0 & 0 \end{pmatrix} \Rightarrow \text{Crystal system} \Rightarrow (\dot{\epsilon}_{kl}^p)_r = (Q_{kl}^T)_r (\dot{\epsilon}_{ij}^p)_r (Q_{jl})_r$$

$$\dot{\sigma}_{ij} = D_{ijkl} \left\{ \dot{\epsilon}_{kl} - \sum_{r=1}^{12} (\dot{\epsilon}_{kl}^p)_r^{\text{oct}} - \sum_{r=1}^6 (\dot{\epsilon}_{kl}^p)_r^{\text{cube}} \right\}$$

$$\text{Global system } \dot{\sigma}_{ij} = R_{ik}^T \dot{\sigma}_{kl} R_{lj}$$

# CONSTITUTIVE MODEL EMPLOYS VISCOPLASTIC EQUATIONS ON OBSERVED MATERIAL SLIP PLANES

The viscoplastic model constants for the octahedral and cube slip systems are not the same. The figure below shows the terms in the evolution equation that were found to be active for the PWA1480 data base. The full model however includes thermal recovery terms in the back stress rate equation and an evolutionary equation for the drag stress which includes latent hardening among like slip systems and cross hardening between the cube and octahedral systems. Details of the mathematical formulation can be found in the reports by Walker and Jordan (1985) and Swanson et. al. (1987).

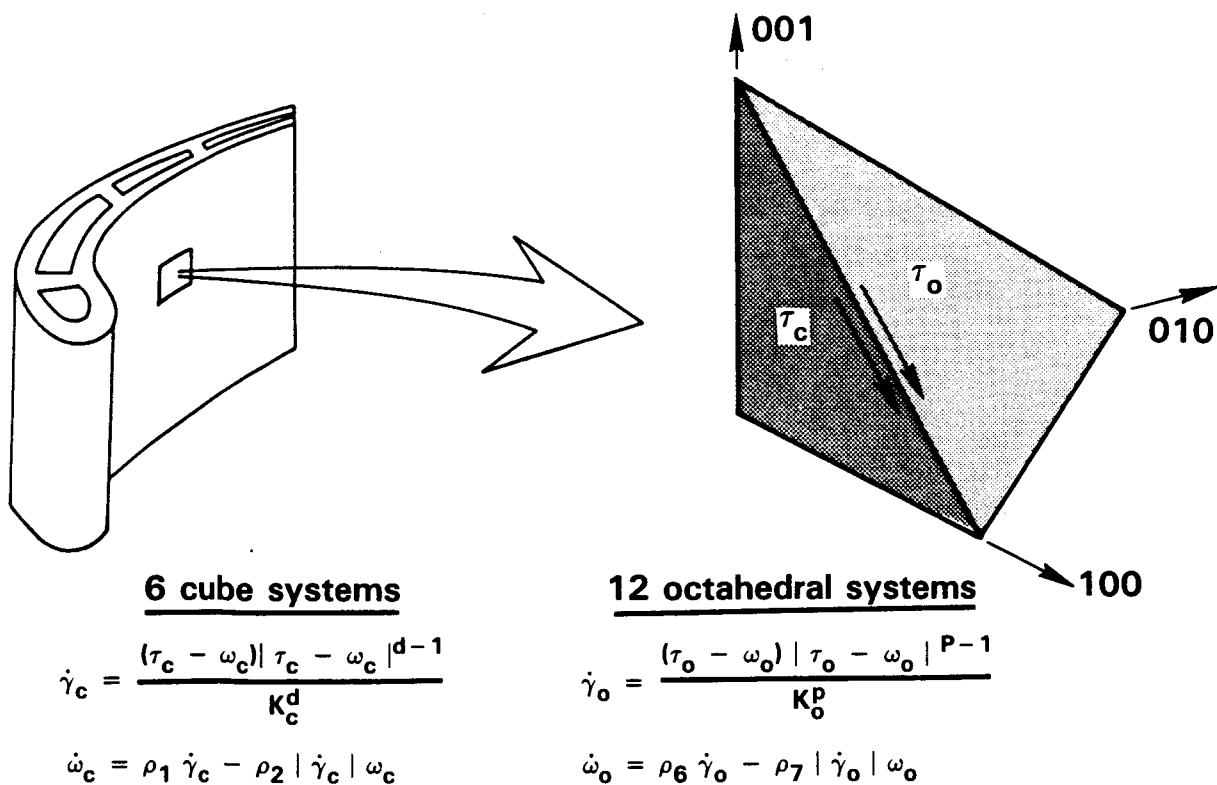



# SINGLE CRYSTAL CONSTITUTIVE MODEL BASED ON CRYSTALLOGRAPHIC SLIP THEORY CAPTURES THE OBSERVED ORIENTATION AND RATE DEPENDENT DEFORMATION BEHAVIOR

A large body of uniaxial cyclic stress - strain data has been obtained from temperatures of 800F to 2100F using specimens oriented in the  $\langle 001 \rangle$ ,  $\langle 111 \rangle$ ,  $\langle 011 \rangle$  and  $\langle 123 \rangle$  directions (Swanson et. al. 1978). Additional torsional stress - strain data has also been obtained (Jordan and Walker, 1985). Strain rates were varied over four orders of magnitude from 1% per sec. to .0001% per sec. The figure below is typical of the correlation with experiment. The slip system based model captures the orientation and rate dependence quite well.

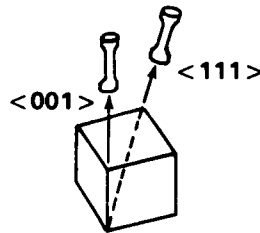

**1600°F steady state cyclic hysteresis loops**

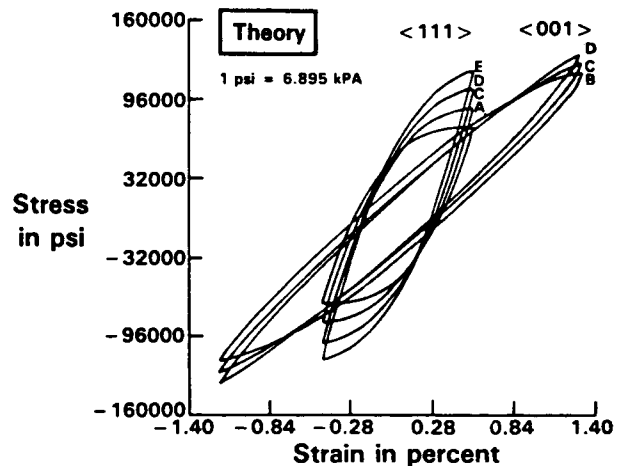
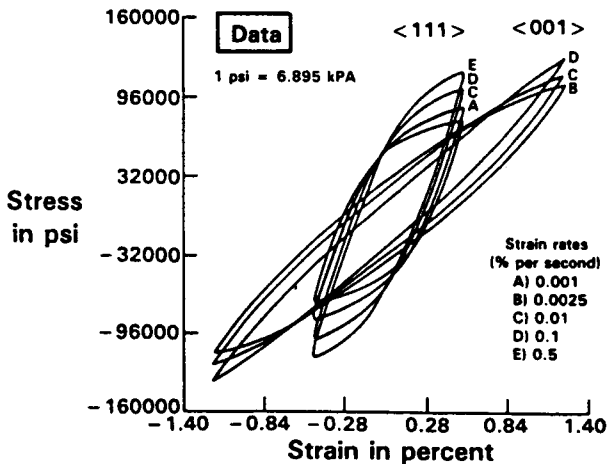

# SLIP BASED CRYSTALLOGRAPHIC CONSTITUTIVE MODEL IS NOW BEING TESTED UNDER THERMOMECHANICAL LOADING CONDITIONS SIMILAR TO THOSE ENCOUNTERED IN SERVICE

The constitutive model has been formulated for use in non-isothermal analyses and is currently being evaluated against a body of thermomechanical loading tests as illustrated in the figure below. In this test cycle, the temperature and imposed strain are varied simultaneously while the stress is monitored. Good correlation has been achieved in the high temperature portion of the cycle. However too much inelasticity is predicted in the low temperature portion. Final adjustments to the model are now being undertaken to address the low temperature response.

**Strain and temperature  
vary sinusoidally with time**

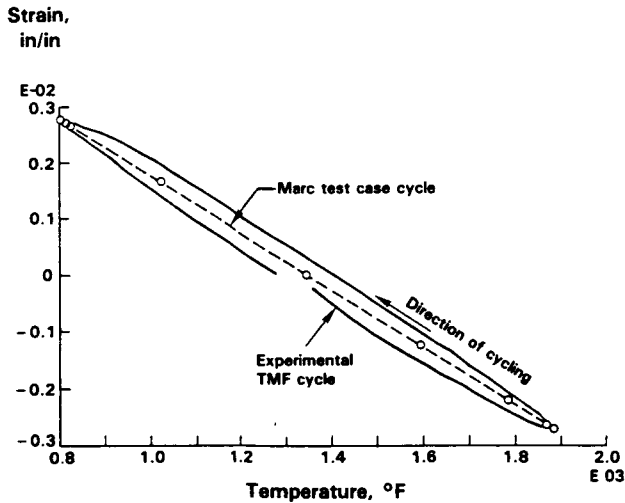

**Stress vs. mechanical strain  
in thermomechanical fatigue test**

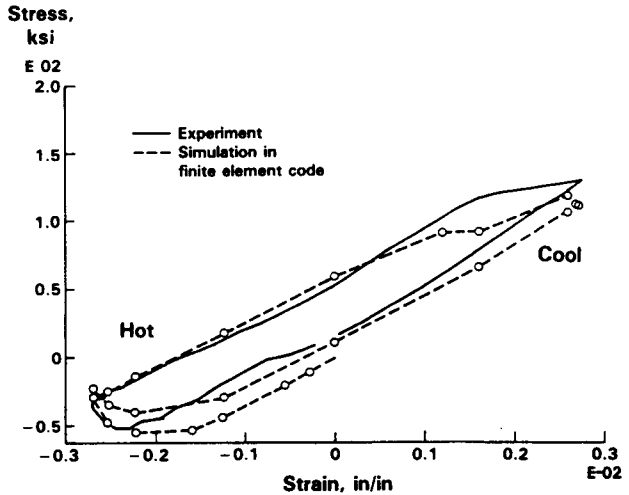

# SINGLE CRYSTAL MODEL CAN EASILY BE INSTALLED AS A SUBROUTINE IN ANY NONLINEAR FINITE ELEMENT PROGRAM

The single crystal model is now operational in the MARC finite element code and is being installed in the "BEST3D" boundary element code under NASA LeRC contract "Inelastic Analysis Methods for Hot Section Components", NAS3-23697. It is also operational in a nonlinear structural analysis code on the IBM PC-XT and is being installed on a 80386-WEITEK desktop/lap personal computer. As part of the current contract effort, the code will be demonstrated in a finite element analysis of a gas turbine hot section component. The constitutive model has been written to be compatible with any finite element code that uses the initial load vector approach for material nonlinearity.

- Start increment N; obtain  $\Delta u$  from previous increment; compute  $\Delta \epsilon = B\Delta u$  } Performed in FE program
- Enter constitutive subroutine and compute D and  $\Delta \zeta$  } Pass D and  $\Delta \zeta$  to FE program

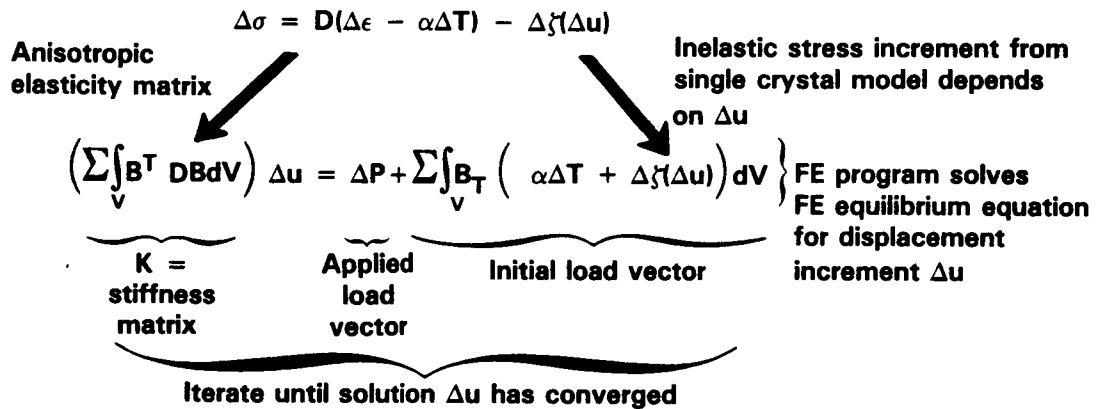

- Update solution and proceed to next increment, N + 1 } Performed in FE program

# THE SINGLE CRYSTAL CONSTITUTIVE RELATIONS CAN BE EXTENDED TO OTHER CLASSES OF MATERIAL BY MEANS OF SELF-CONSISTENT MODELS

This slip system based model for single crystal material offers the opportunity to develop constitutive models for other classes of materials by means of self-consistent methods (Walker, 1984). Directionally solidified materials consist of aligned columnar single crystal grains which are oriented at random in the basal plane perpendicular to the solidification direction. This random orientation of grains produces a material with transversely isotropic properties. A self consistent method for modeling this material is achieved by surrounding a particular single crystal columnar grain with a transversely isotropic material. Using methods proposed by Eshelby (1957), the properties of the surrounding transversely isotropic material are found by averaging the properties of the single crystal grain which has been constrained by the surrounding material. The averaging is done about the axis of the columnar grain.

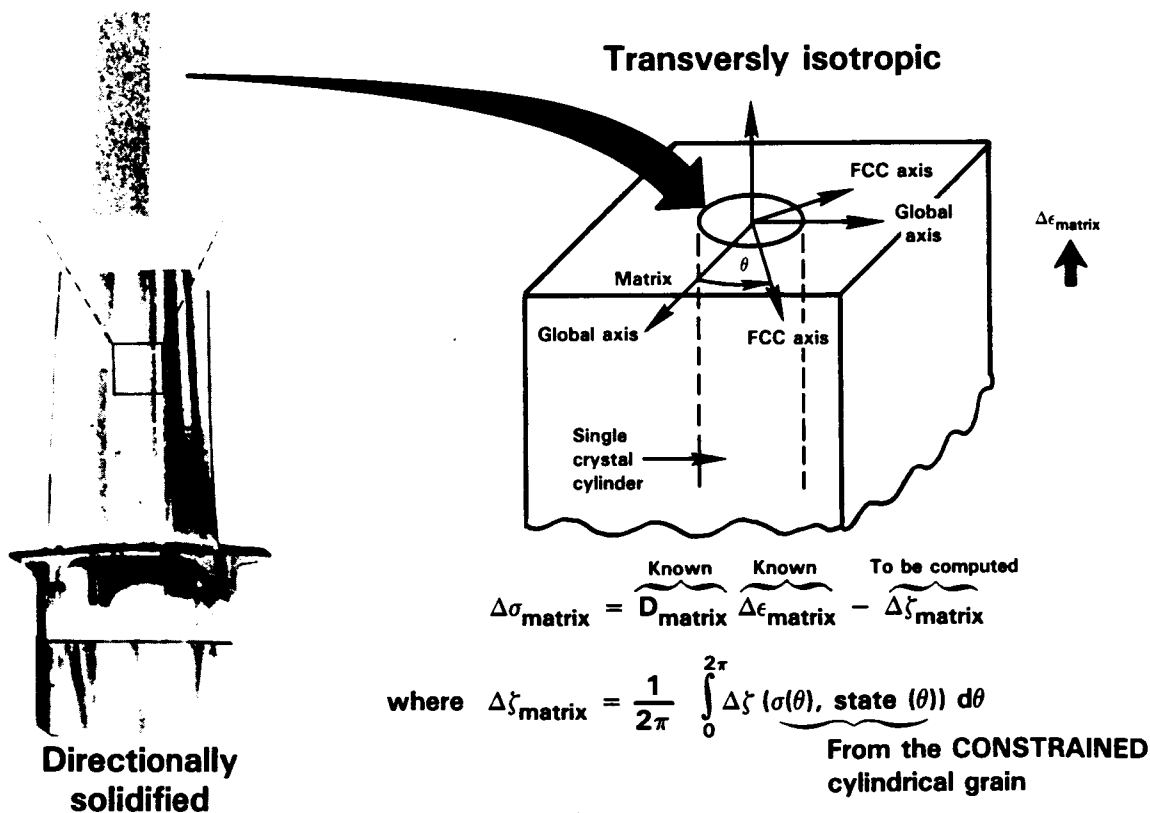

# EXTENSION OF THE SINGLE CRYSTAL CONSTITUTIVE RELATIONS TO ISOTROPIC MATERIALS BY MEANS OF A SELF CONSISTENT MODEL

Using a similar self consistent approach, it is possible to develop a constitutive model for isotropic materials. In this case the averaging in the constrained grain must be done with respect to all directions.

In both of these cases, transversely isotropic and isotropic, the slip system formulation developed in this effort can serve as the base model for the grains. Appropriate model constants for the particular material would of course be required and the influence of grain boundary sliding may require additional modeling.

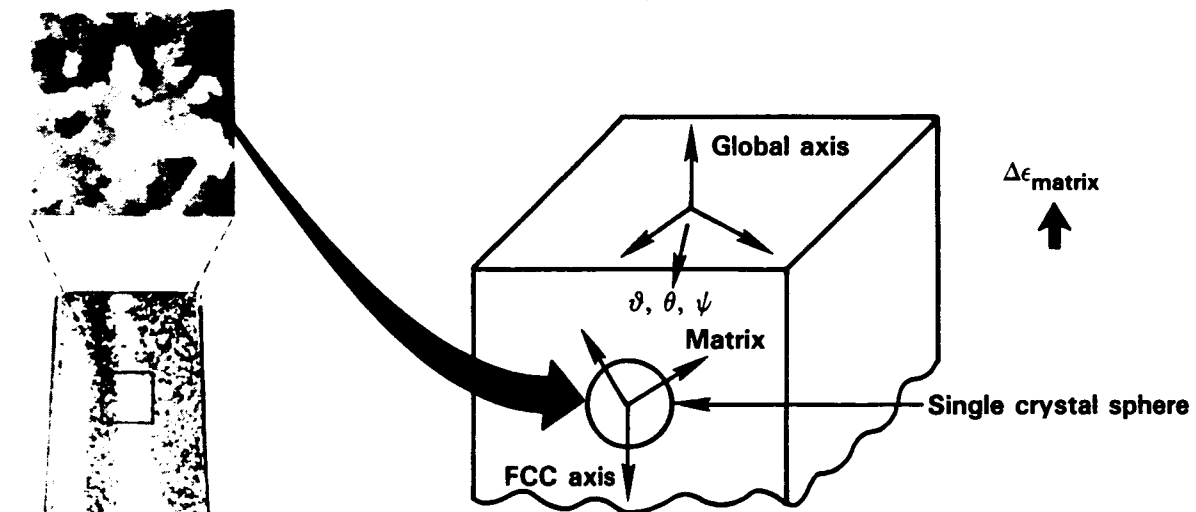

Conventionally cast

$$\Delta\sigma_{\text{matrix}} = \underbrace{D_{\text{matrix}}}_{\text{Known}} \underbrace{\Delta\epsilon_{\text{matrix}}}_{\text{Known}} - \underbrace{\Delta\zeta_{\text{matrix}}}_{\text{To be computed}}$$

Where

$$\Delta\zeta_{\text{matrix}} = \frac{1}{8\pi^2} \int_0^{2\pi} d\phi \int_{-\pi/2}^{\pi/2} d\theta \int_0^{2\pi} \sin\theta \Delta\zeta(\sigma(\theta, \phi, \psi), \text{state}(\theta, \phi, \psi)) d\psi$$

# WHAT IS THE CURRENT STATE OF OUR TECHNOLOGY?

The single crystal constitutive model developed in this effort represents an advance in the state of our technology for durability prediction. A structural analysis using the single crystal constitutive model can now be used to obtain a more accurate stress - strain response at the fatigue critical location of a component. These more accurate results can now be used to develop more accurate life models. Global stress and strain quantities as well as slip systems quantities are available from the model for life prediction.

A similar, although more complicated, approach is envisioned for composite materials. In these materials, the size scale of the material constituents relative to the overall composite structure prohibits modeling individual fibers and their surrounding matrix explicitly throughout the entire structure. Instead, a homogenized or "smeared" material model could be constructed for the bulk properties of the composite by assuming some periodicity of the fibers in the matrix and then volume averaging the constituent responses. This homogenized material model can then be used in the structural analysis program to obtain the overall composite structure's response. Damage models can be developed based on these "smeared" results directly or these results can be used as boundary conditions on a composite sub-element. The same constituent material models that were used to obtain the smeared material model can now be used to obtain local fiber/matrix stresses and strains in the sub-element.

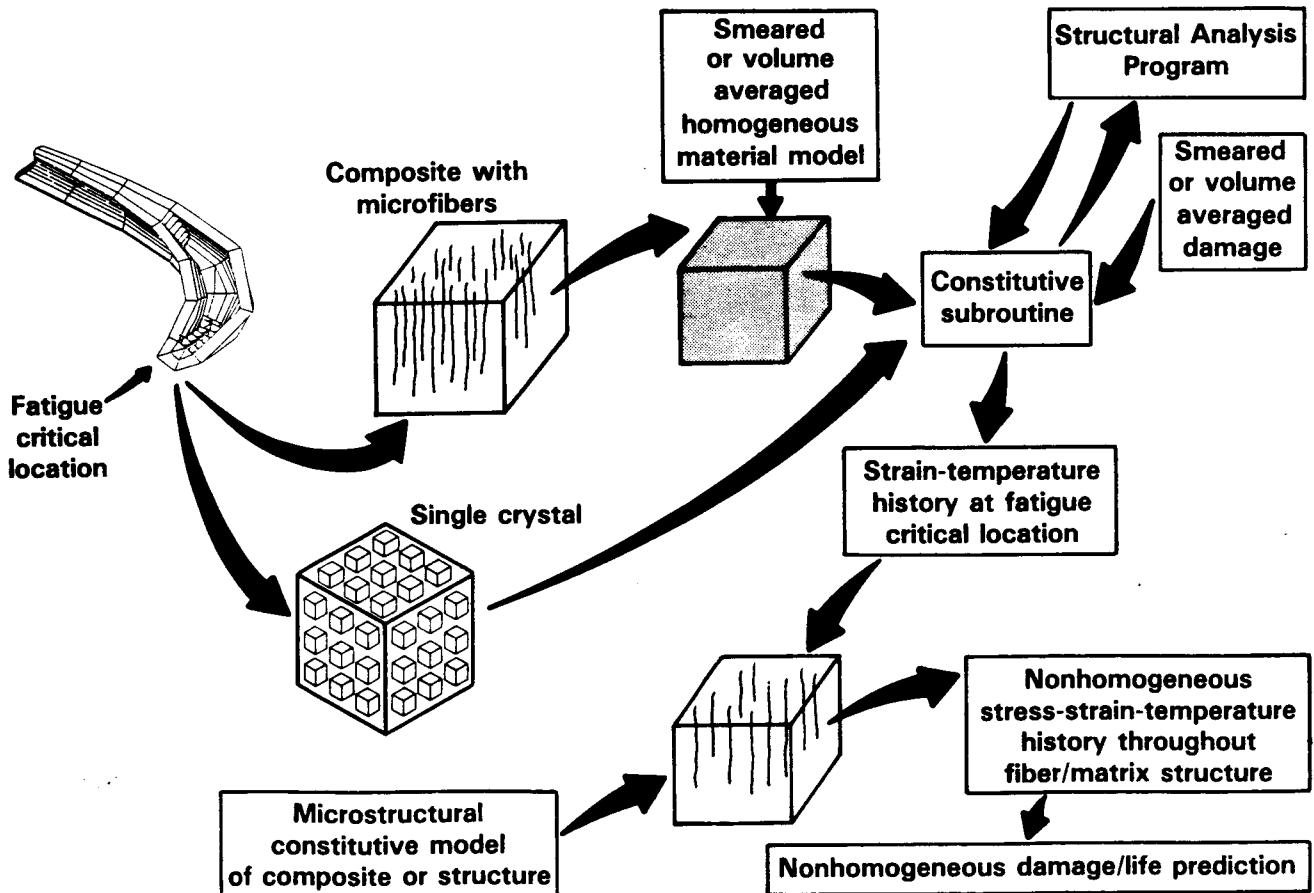

LeRC LST'88

## References

Eshelby, J. D., "The Determination of the Elastic Field of an Ellipsoid Inclusion, and Related Problems," Proc. Royal Society of London, A241, p376, 1957.

Hill, R., "A Theory of the Yielding and Plastic Flow of Anisotropic Metals," Proc. Royal Society of London, Ser. A Vol. 193, pp. 281-297, 1948.

Jordan, E. H. and Walker, K. P., "Biaxial Constitutive Modeling and Testing of a Single Crystal Superalloy at Elevated Temperature," presented at the Second International Conference on Biaxial/Multiaxial Fatigue, Sheffield, England, December 1985. To appear in Fatigue and Fracture of Engineering Materials and Structures.

Lee, D., Zaverl, F. Jr., Shih, C. F., and German, M. D., "Plasticity Theories and Structural Analysis of Anisotropic Metals," Report No. 77CRD285, General Electric Corporate Research and Development Center, Schenectady, New York, 1977.

Swanson, G. A., I. Linask, D. M. Nissley, P. P. Norris, T. G. Meyer, and K. P. Walker, "Life Prediction and Constitutive Models for Engine Hot Section Anisotropic Materials Program, Annual Status Report, " Nasa CR-174952, February, 1986.

Walker, K. P., "Research and Development for Nonlinear Structural Modeling with Advanced Time-Temperature Dependent Constitutive Relationships," NASA CR-165533, November 1981.

Walker, K. P. and Jordan, E. H., "Constitutive Modeling of Superalloy Single Crystal and Directionally Solidified Materials," NASA CP-2369, pp 65 - 81, 1984.

Walker, K. P. and Jordan, E. H., "First Annual Report on NASA Grant NAG3-512," 1985.