

N 88 - 22392

THREE-DIMENSIONAL INELASTIC APPROXIMATE ANALYSIS CODE (MOMM)

Jeffrey P. Meister*
Sverdrup Technology, Inc.
Lewis Research Center Group
NASA Lewis Research Center

ABSTRACT

The Mechanics of Materials Model (MOMM) is one of a series of new stand-alone three-dimensional nonlinear structural analysis codes developed under the Three-Dimensional Inelastic Analysis Methods Program. The primary goal of the program was to address the need for more efficient and accurate three-dimensional structural analysis procedures for hot-section engine components. General-purpose finite element computer codes containing a variety of inelastic material models have been available for more than a decade. Incorporation of such codes into the hot-section design process has been severely limited by the high costs associated with such analyses and the difficulties encountered in properly defining the nature of the problem under consideration by using such codes.

The initial development of the Mechanics of Materials Model was conducted by United Technologies Research Center under the direction of NASA Lewis Research Center as a part of the Hot Section Technology Program. MOMM is a stiffness-method finite element code that uses an internally generated network of beams to characterize hot-section component behavior. The method was proposed as a fast, easy to use, computationally efficient tool for approximate analyses. The code is intended for applications during early phases of component design. MOMM incorporates a wide variety of analysis capabilities, material models, and load type specifiers instrumental for the analysis of hot-section components.

*Work performed on-site at the Lewis Research Center for the Structural Mechanics Branch.

FRAMEWORK REPRESENTATION OF A CONTINUOUS SURFACE

The Mechanics of Materials Model represents a continuous surface structure by a network of beams, thus reducing the elastomechanics of a continuous surface structure to the analysis of a beam or grid network. The substitute beam network is internally generated by using concepts derived from the framework method. A six-beam structure, called a framework cell, is the basic building block of the framework method. The user inputs the four nodes defining the framework cell, the thickness of the continuum, and the material properties of the continuum, and MOMM generates the appropriate substitute beam network.

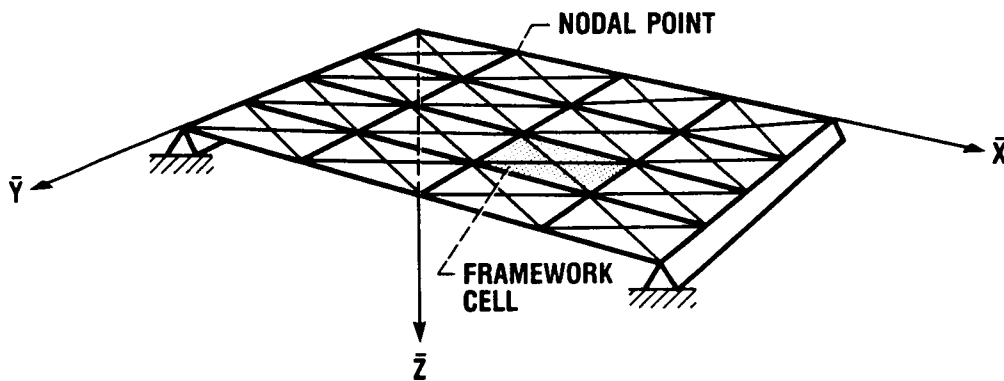

CD-88-31911

SIMULATION OF IN-PLANE DEFORMATION

The in-plane deformation of the framework cell is controlled by the cross-sectional area of the beam members composing the framework cell. The cross-sectional areas of the beam members are determined by equivalencing the nodal displacements of a plate subject to states of constant stress and a framework cell subject to statically equivalent nodal forces. Thus the framework method solution will converge upon the exact solution for the generalized load case as the mesh is refined and the stress acting upon the individual cells approaches a state of constant stress.

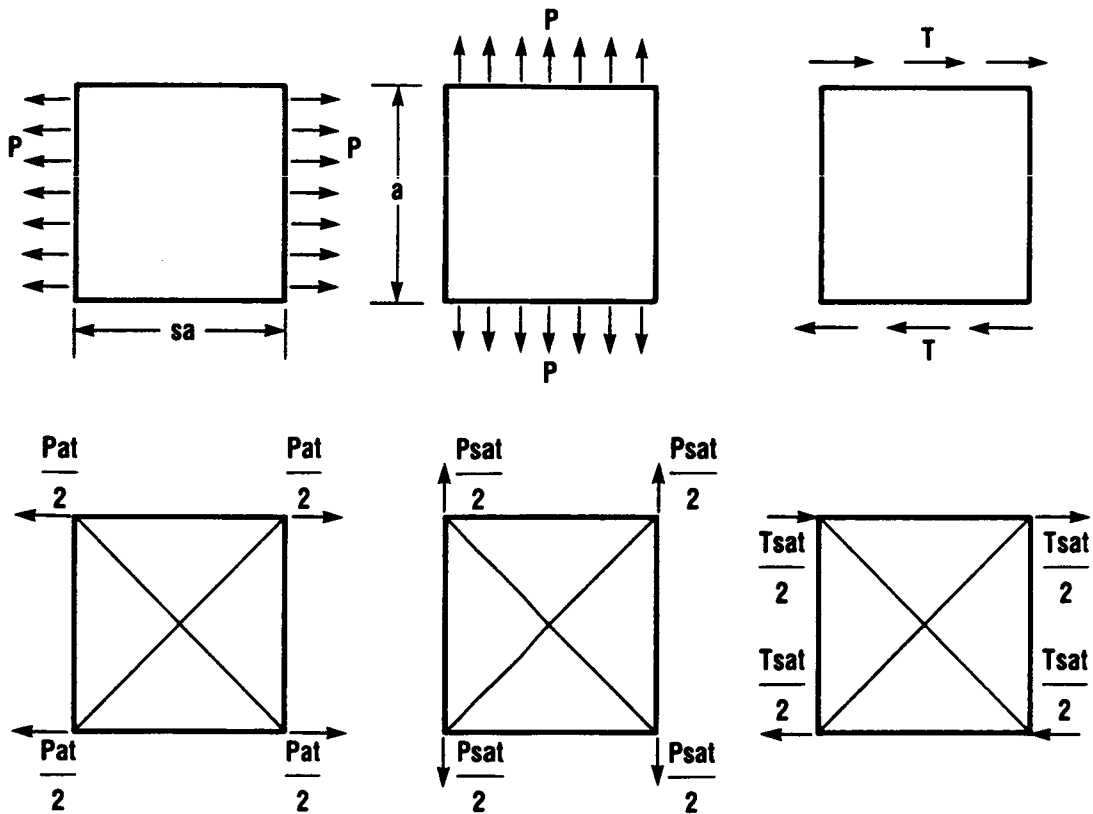

CD-88-31912

SIMULATION OF PLATE BENDING

The bending behavior of the framework cell is controlled by the cross-sectional moments of inertia of the cells' beam members. These moments are determined by equivalencing the nodal displacements of a plate subject to constant edge moments and a framework cell subject to statically equivalent nodal forces. Thus the framework method solution will converge upon the exact solution for the generalized load case as the mesh is refined and as the edge moments acting upon the individual framework cells converge to a constant state.

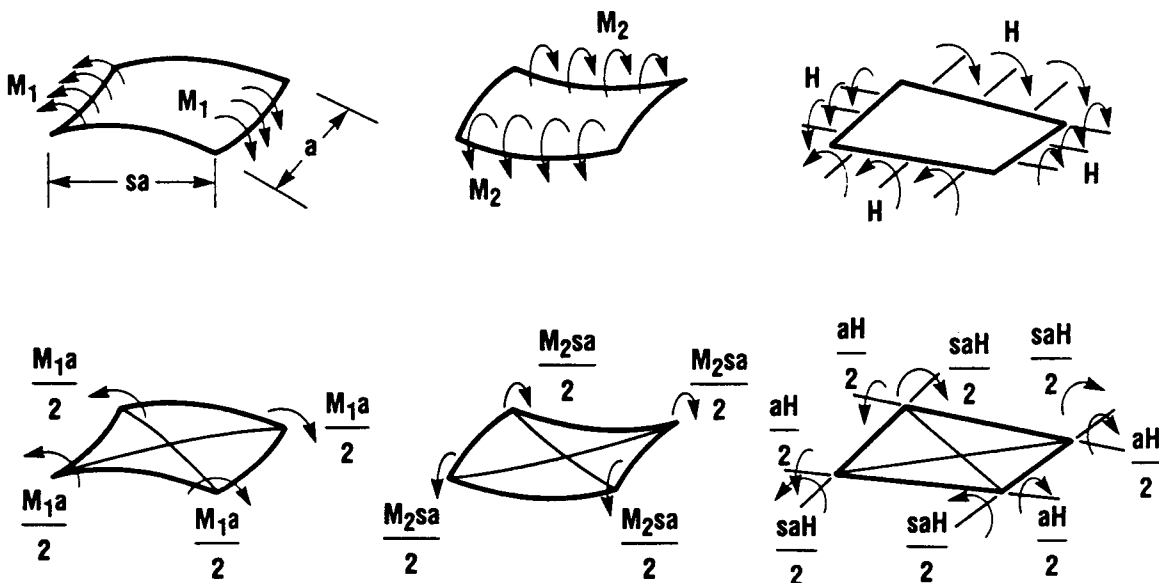

CD-88-31913

ANALYSIS CAPABILITIES AND LOAD TYPES

The Mechanics of Materials Model contains a variety of useful analysis capabilities; these include static analysis capabilities, transient analysis capabilities using Newmark's integration scheme, and buckling and frequency analysis capabilities using eigenvalue extraction techniques on either the initial or the tangent stiffness matrix. A wide variety of load types may also be prescribed by using MOMM; these include applied loads (concentrated loads, line loads, pressure loads, centrifugal loads), enforced displacements, and thermal loads.

ANALYSIS CAPABILITIES

- **STATIC**
- **TRANSIENT—NEWMARK INTEGRATION SCHEME**
- **FREQUENCY—EIGENVALUE EXTRACTION USING INITIAL OR TANGENT STIFFNESS**
- **BUCKLING—EIGENVALUE EXTRACTION USING INITIAL OR TANGENT STIFFNESS**

LOAD TYPES

- **APPLIED LOADS**
 - **CONCENTRATED LOADS**
 - **LINE LOADS**
 - **PRESSURE LOADS**
 - **CENTRIFUGAL LOADS**
- **ENFORCED DISPLACEMENTS**
- **THERMAL LOADS**

CD-88-31914

CONSTITUTIVE MODELS

The Mechanics of Materials Model contains three material models with varying levels of sophistication. The first model, called the Simplified Material Model, assumes a bilinear stress-strain response and generally glosses over the complications associated with strain rate effects. The second model, called the State-of-the-Art Material Model, partitions time-independent (plasticity) and time-dependent (creep) phenomena in the conventional manner, invoking Mises yield criteria and standard (isotropic, kinematic, combined) hardening rules for plasticity and a steady-state power law for creep. The third and most sophisticated model, called the Modified Walker's Model, is a modified version of Walker's viscoplastic model. This model accounts for the interaction between creep and plasticity that occurs under cyclic loading conditions.

- **SIMPLIFIED MATERIAL MODEL**
 - **USES BILINEAR STRESS-STRAIN CURVE BASED UPON ELASTIC MODULUS AND HARDENING SLOPE**

- **STATE-OF-THE-ART MATERIAL MODEL**
 - **ELASTIC-PLASTIC-CREEP STRAIN DECOMPOSITION**
 - **STEADY-STATE POWER LAW CREEP MODEL**
 - **PLASTICITY MODEL CONTAINS ISOTROPIC AND KINEMATIC HARDENING**

- **MODIFIED WALKER'S MODEL**
 - **UNIFIED VISCOPLASTIC MODEL**
 - **ACCOUNTS FOR INTERACTION OF CREEP AND PLASTICITY UNDER CYCLIC LOADING**

CD-88-31915

NONLINEAR SOLUTION ALGORITHM

The Mechanics of Materials Model contains an efficient solution algorithm. The stiffness matrix is constructed only once and all stiffness changes and inelastic strains are incorporated in a residual load vector. Convergence is satisfied if the relative difference between the internal stress resultant and the externally applied load is within the user-specified tolerance.

- **STIFFNESS MATRIX CONSTRUCTED ONCE—STIFFNESS CHANGES AND INELASTIC STRAINS INCORPORATED IN RESIDUAL-LOAD VECTOR**

$$K \Delta u = \Delta P + P - F + I$$

K GLOBAL STIFFNESS MATRIX
 Δu INCREMENTAL DISPLACEMENT
 ΔP INCREMENTAL LOAD
P CUMULATIVE LOAD, INCLUDING ΔP
F INTERNAL STRESS RESULTANT DUE TO P
I RESIDUAL LOAD DUE TO INELASTIC STRAINS

- **CONVERGENCE SATISFIED IF INTERNAL STRESS RESULTANT BALANCES EXTERNALLY APPLIED LOADS**

$$\frac{|P| - |F|}{|P|} < \text{TOLERANCE}$$

CD-88-31916

MESH SIZE SENSITIVITY - CANTILEVERED PLATE

A cantilevered plate subject to three in-plane load cases was analyzed by using the Mechanics of Materials Model in order to investigate the codes ability to model in-plane deformation. In load case 1 the plate was subjected to an axial load, which induces a state of constant stress. As illustrated in the results shown below, the MOMM solution was equal to the exact solution for all mesh sizes analyzed. The high accuracy of these results should be expected since the framework method was formulated to characterize the behavior of a plate subjected to a constant stress state. In load cases 2 and 3 the plate was subjected to a vertical shear force and a force couple. As illustrated below, the MOMM solution approached the exact solution as the mesh was refined.

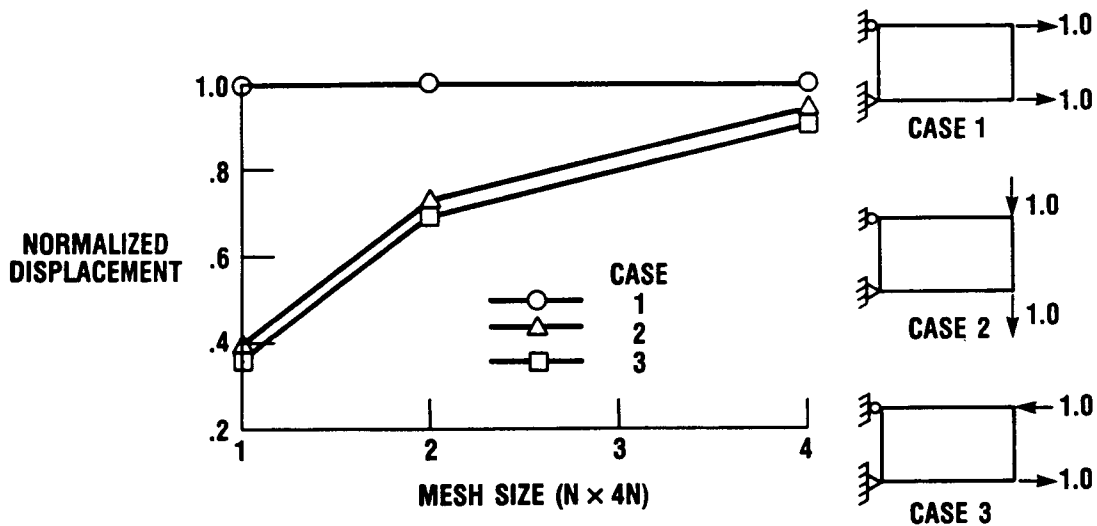

CD-88-31917

MESH SIZE SENSITIVITY - CLAMPED PLATE

A clamped plate subjected to a transverse load was analyzed by using the Mechanics of Materials Model in order to investigate its ability to model bending. A concentrated load was applied at the plate's center, and because of symmetry only one-quarter of the plate was modeled. As illustrated in the graph shown below, the MOMM solution converged upon the exact solution with minimal mesh refinement.

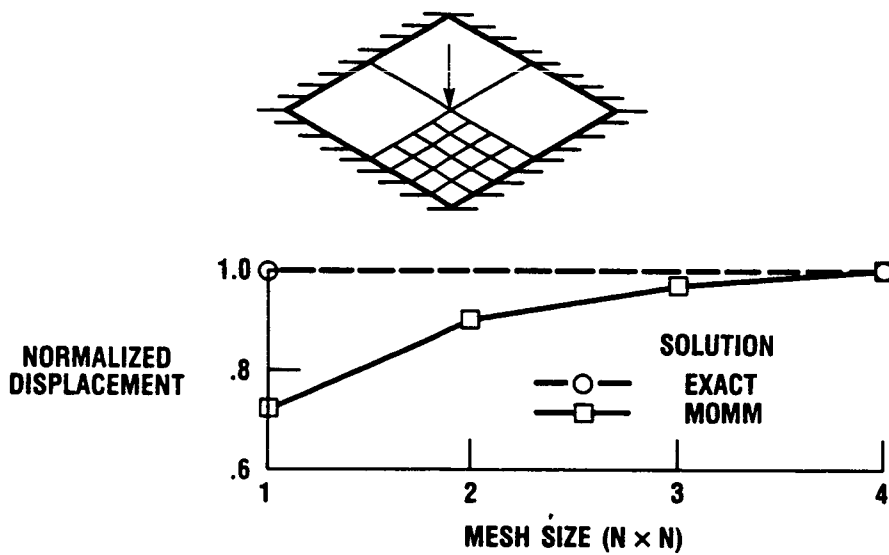

CD-88-31918

MESH SIZE SENSITIVITY - CYLINDRICAL SHELL ROOF

A cylindrical shell roof loaded by its own weight was analyzed in order to investigate the ability of the Mechanics of Materials Model to model combined in-plane deformation and bending. The shell roof was supported by rigid diaphragms, and only one-quarter of the structure was modeled because of symmetry. Membrane and bending deformations both contribute significantly to this problem. As shown below, the Mechanics of Materials Model Solution approaches the exact solution at a slow rate of convergence, reflecting the framework cells' weakness in modeling in-plane bending.

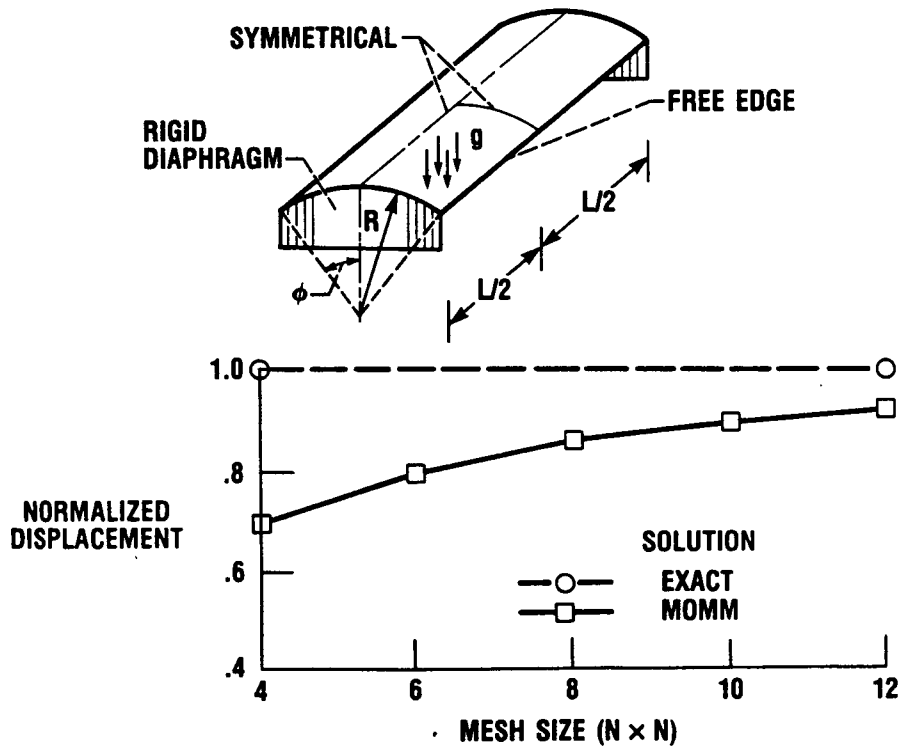

CD-88-31919