

N 8 8 - 2 2 3 9 6

COMPUTATIONAL SIMULATION METHODS FOR COMPOSITE
FRACTURE MECHANICS

Pappu L.N. Murthy*
Cleveland State University
Cleveland, Ohio 44115

ABSTRACT

The task of assessing the structural integrity, durability, and damage tolerance of advanced composites from a design viewpoint is twofold. First, damage initiation at various scales (micro, macro, and global) and accumulation and growth leading to global failure must be qualitatively as well as quantitatively assessed. Second, various fracture toughness parameters associated with a typical damage and its growth must be determined. These two points have been the subjects of ongoing research at the NASA Lewis Research Center over the past 10 years. The objective of this research has been to develop computational structural analysis codes to aid the composites design engineer in routinely performing these tasks. The computational simulation methods involved in this research effort are described in this presentation.

The first part of the effort concerns the qualitative as well as quantitative assessment of progressive damage occurring in composite structures due to mechanical and environmental loads. A computer code, CODSTRAN, and an experimental setup to verify the predictions of the code have been under development (Chamis and Smith, 1978; Chamis, 1986; and Ginty, 1985). CODSTRAN stands for composite durability structural analysis. Some of the salient features of CODSTRAN are presented with an illustrative example and results.

The second part of the presentation covers methods that are currently being developed and used at Lewis to predict interlaminar fracture toughness and related parameters of fiber composites given a prescribed damage (Murthy and Chamis, 1985; Murthy and Chamis, 1986). The general-purpose finite element code MSC/NASTRAN is used to simulate the interlaminar fracture and the associated individual as well as mixed-mode strain energy release rates in modes I, II, and III in fiber composites. Those methods can be conveniently embedded into CODSTRAN to develop a unique computational capability to analyze and design progressive damage and crack growth in fiber composites.

*Senior Research Associate.

CODSTRAN: COMPOSITE PROGRESSIVE DAMAGE ANALYZER

The computer code CODSTRAN follows an "upward-integrated and topdown-traced" architecture as depicted in the viewgraph. In this, CODSTRAN follows very closely all the steps that are involved in manufacturing a component, starting from constituents (fiber and matrix). The code starts with fiber and matrix properties, forms a laminate by using classical lamination theory, and arrives at a finite element representation. After the finite element analysis is completed, the loads at each node are used in the progressive decomposition to arrive at the constituent-level response. The response is reviewed, and either the properties are updated or the load step is increased or decreased. All this is automatically done by the code with minimal user intervention.

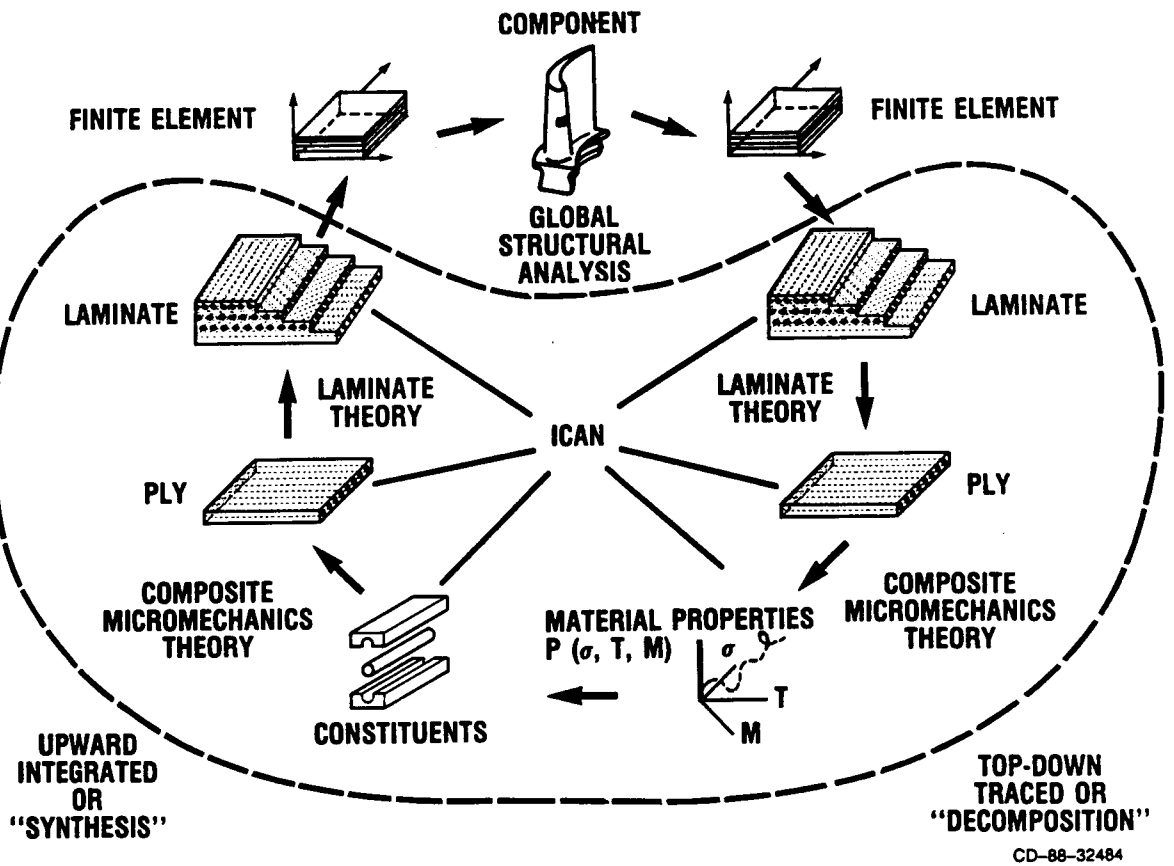

CD-88-32484

CODSTRAN COMPUTER CODE DESCRIPTION

This flowchart shows some of the important analysis modules that are embedded in CODSTRAN. Many of these modules are constructed in such a way that user updates are possible with a minimum effort. The code is open ended and stand alone except for the graphics module, which may need to be modified depending on the system facilities available at the user station. The code comes with a dynamic storage allocation scheme for optimal usage of computer storage. Restart facilities are provided within the code to take care of abnormal termination or system failures. Dedicated model generators can be easily updated by the user to take care of specific requirements.

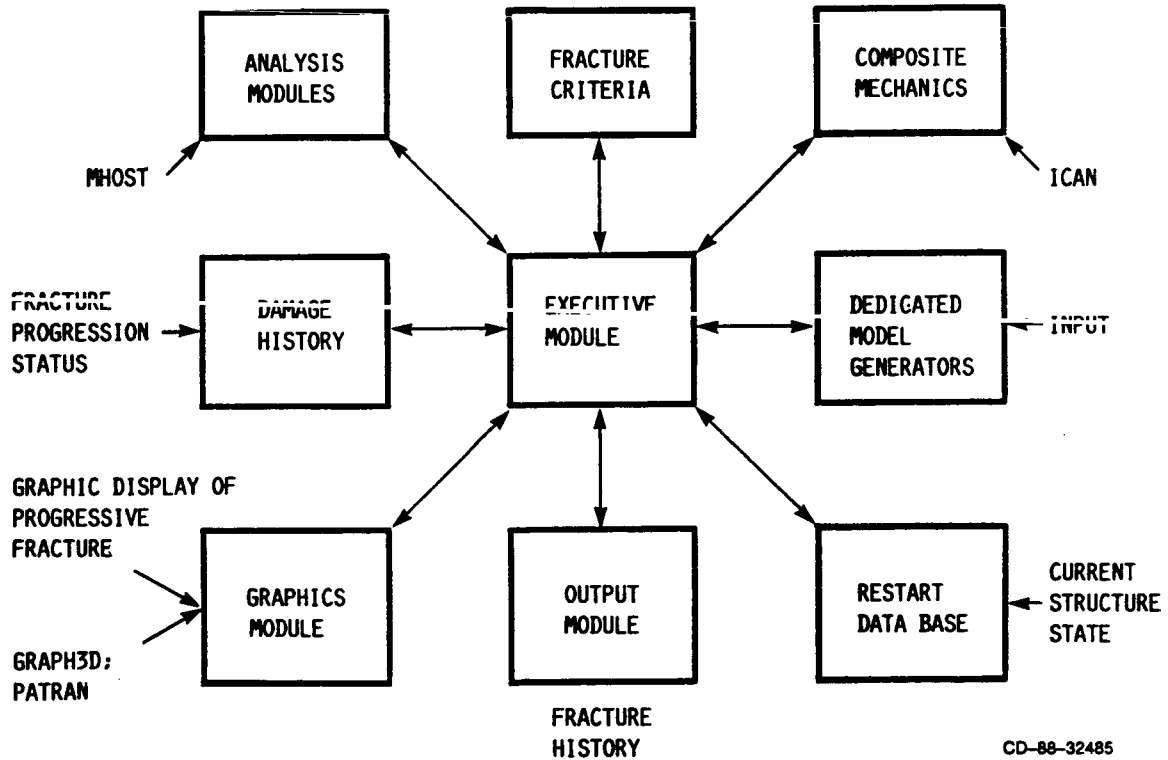

CD-88-32485

DEDICATED MESH GENERATOR OUTPUT

Two finite element representations as generated by the dedicated model generator modules in CODSTRAN are shown below for a $(0^\circ/30^\circ/0^\circ/-30^\circ/0^\circ)_{2s}$ graphite/epoxy laminate with a notch in the center. The coarse mesh provides quick estimates. The fine-mesh representation may have to be used to obtain a more accurate description of the damage progression.

LAMINATE CONFIGURATION, $(0^\circ/30^\circ/0^\circ/-30^\circ/0^\circ)_{2s}$ GRAPHITE/EPOXY

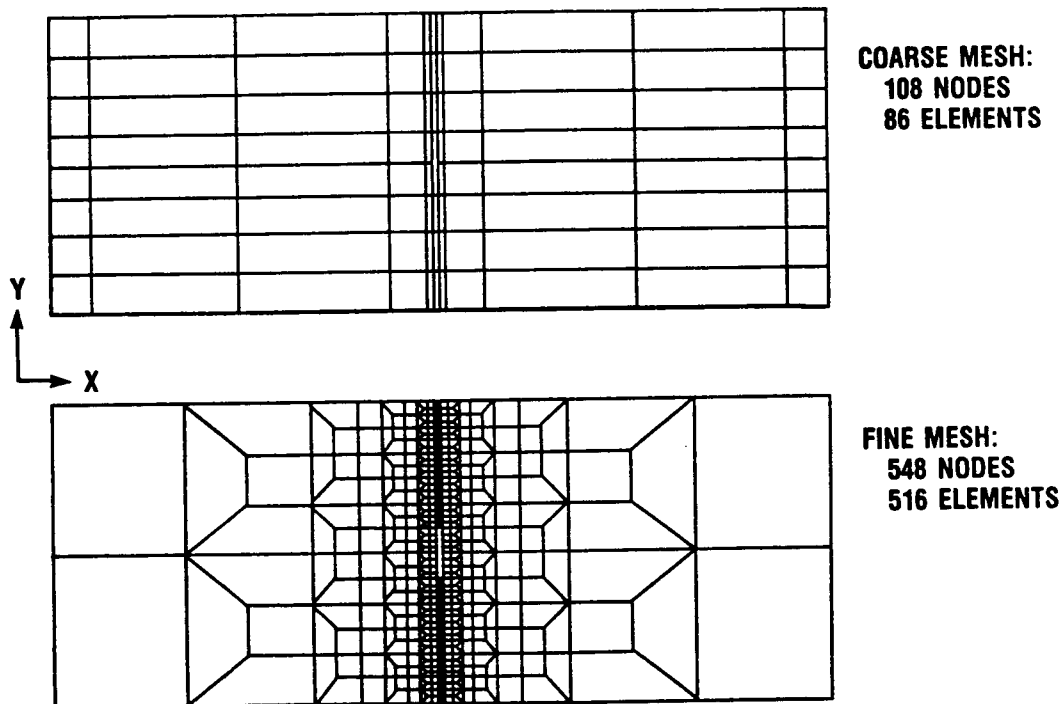

CD-88-32486

CODSTRAN-PREDICTED SEQUENCE OF PROGRESSIVE FRACTURE

The laminate in the previous figure is subjected to a tensile load applied in small increments. Damage is tracked down at various load steps, as shown, until a complete global failure occurs. The plots are made with the aid of an in-house-developed graphics package, GRAPH3D. Also, at any stage the user may obtain ply, laminate stress, or displacement contours with PATRAN. Special translators are built in the code to generate PATRAN-compatible output.

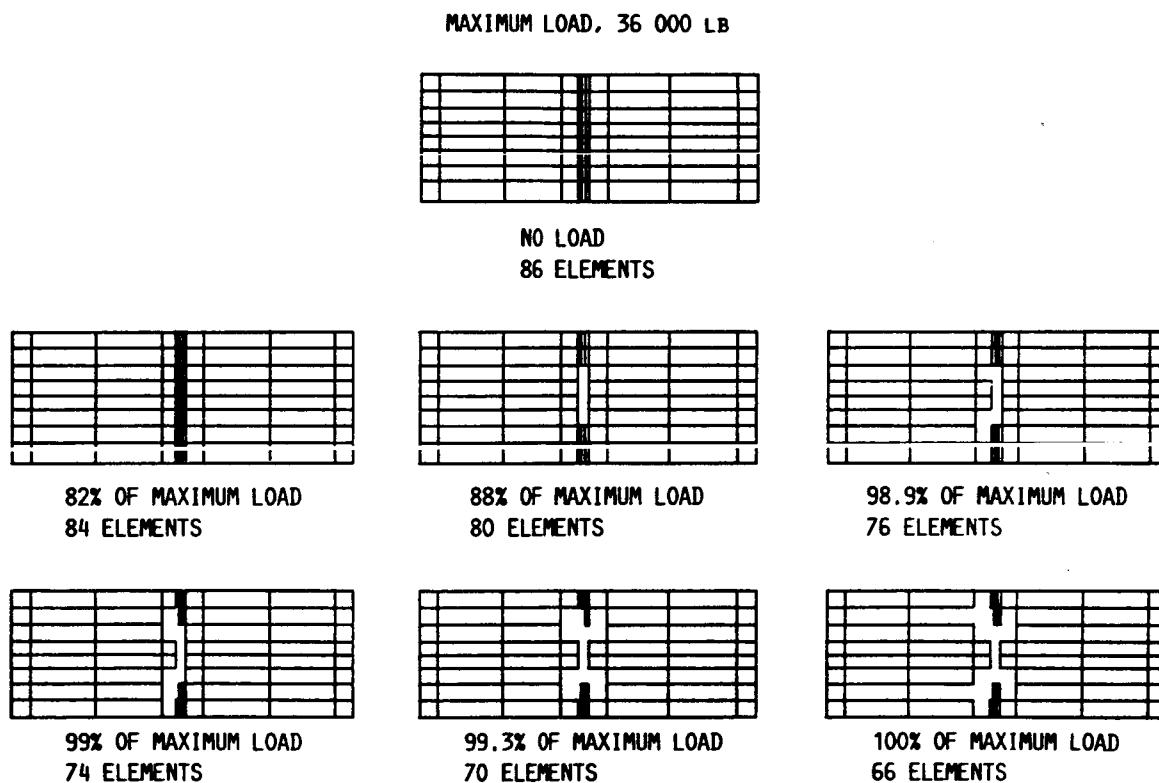

CD-88-32487

SCHEMATIC OF FLEXURE TEST FOR INTERLAMINAR FRACTURE MODE TOUGHNESS

This figure shows two proposed ASTM standard specimens - end-notch flexure (ENF) and mixed-mode flexure (MMF). They are essentially modifications of the standard three-point bend test specimens with end notches. The ENF specimen simulates pure shear-mode fracture (mode II). The MMF specimen simulates mixed-mode (modes I and II) fracture. These specimens are modeled with three-dimensional finite elements and are analyzed by using MSC/NASTRAN to obtain mode II and mixed-mode I and II strain energy release rates for a variety of laminate configurations (Murthy and Chamis, 1985 and 1986).

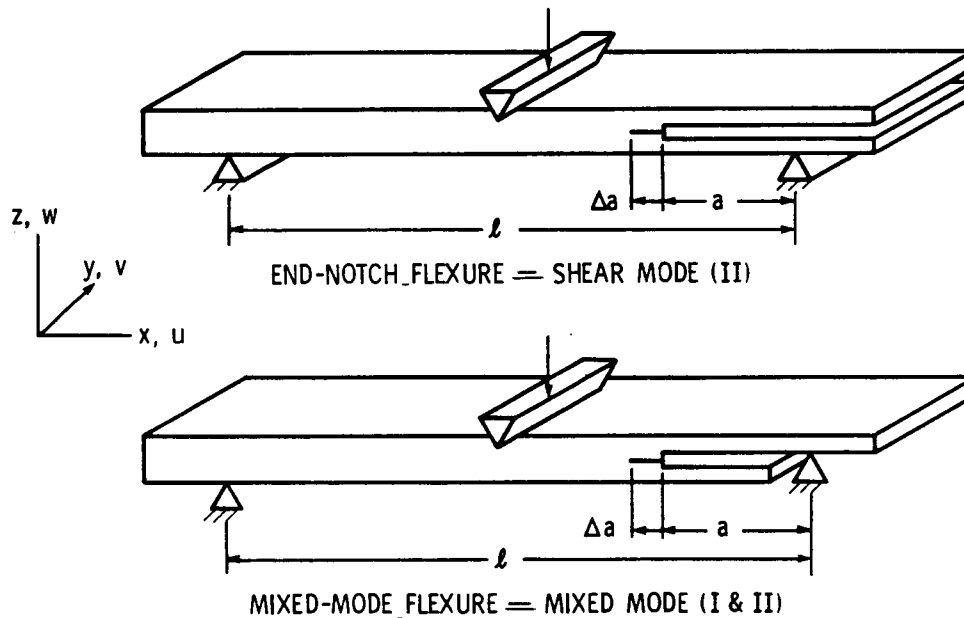

CD-88-32488

FINITE ELEMENT DEFORMED MODEL RIGHT-HALF-SPAN MIXED-MODE
FLEXURE (GRAPHITE/EPOXY)

The finite element discretization for the right half span of the MMF specimen is shown in the figure. The elements used were eight-node three-dimensional bricks. The crack tip region was further substructured into a fine mesh as shown in the following figures. Increasing crack lengths were obtained by removing elements from the interply region ahead of the crack tip, and several finite element analyses were run. By using a special "single-point constraint" approach and the virtual crack closure technique, the energy release rates associated with the individual modes I and II were obtained. For details refer to Murthy and Chamis (1985 and 1986).

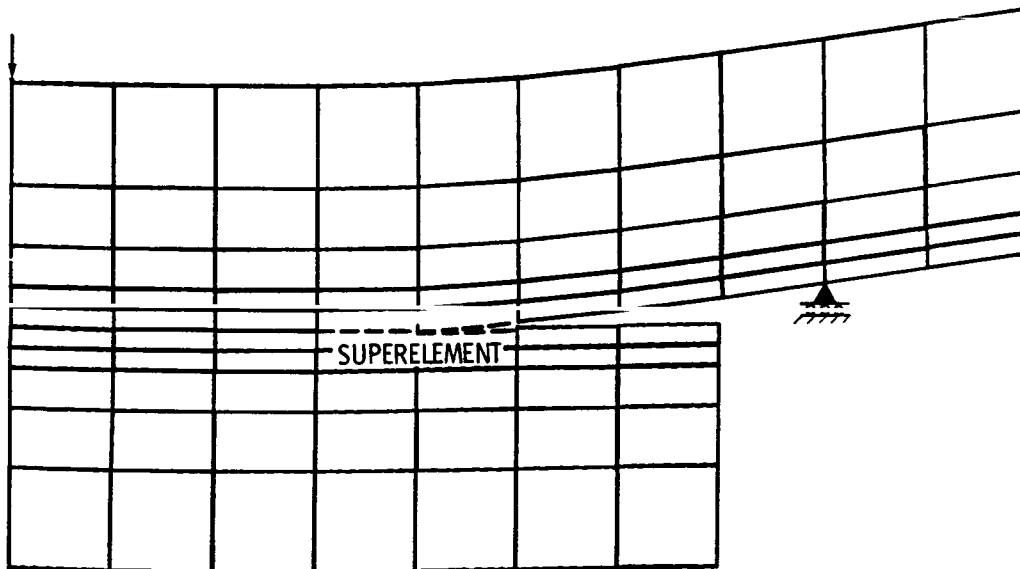

CD-88-32489

CRACK REGION SUPERELEMENT MODEL DETAILS - FRONT VIEW

The crack tip region was modeled as shown. It contains a total of 360 brick elements of which 32 are six-node pentahedrons and 328 are eight-node hexahedrons. The eight-node bricks in the interply layer ahead of the crack tip were removed progressively one by one to simulate extended crack length.

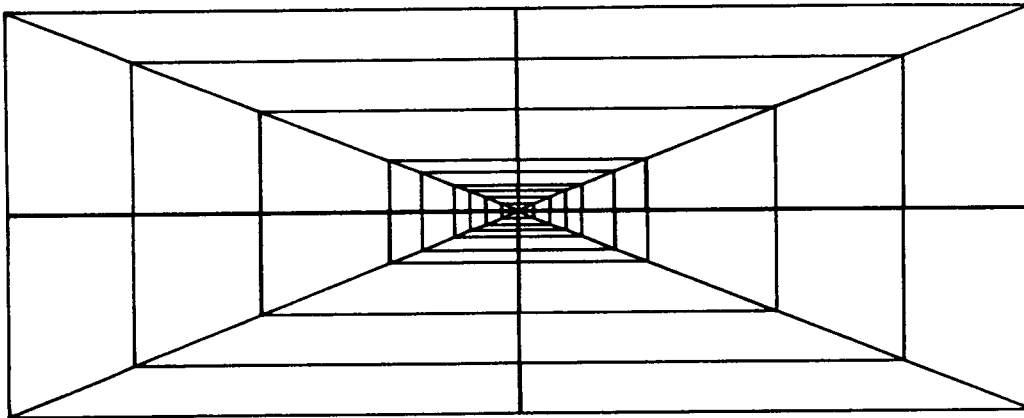

- 360 BRICKS
- 32 SIX-NODE PENTAHEDRONS
- 328 EIGHT-NODE HEXAHEDRONS

CD-88-32490

END-NOTCH-FLEXURE ENERGY RELEASE RATE COMPARISONS

The global strain energy release rate G based on the measurement of deflections at the midspan and the local energy release rate computed by using the virtual crack closure technique are compared in the figure. Also the measured critical strain energy release rates for this specimen are shown by horizontal dashed lines.

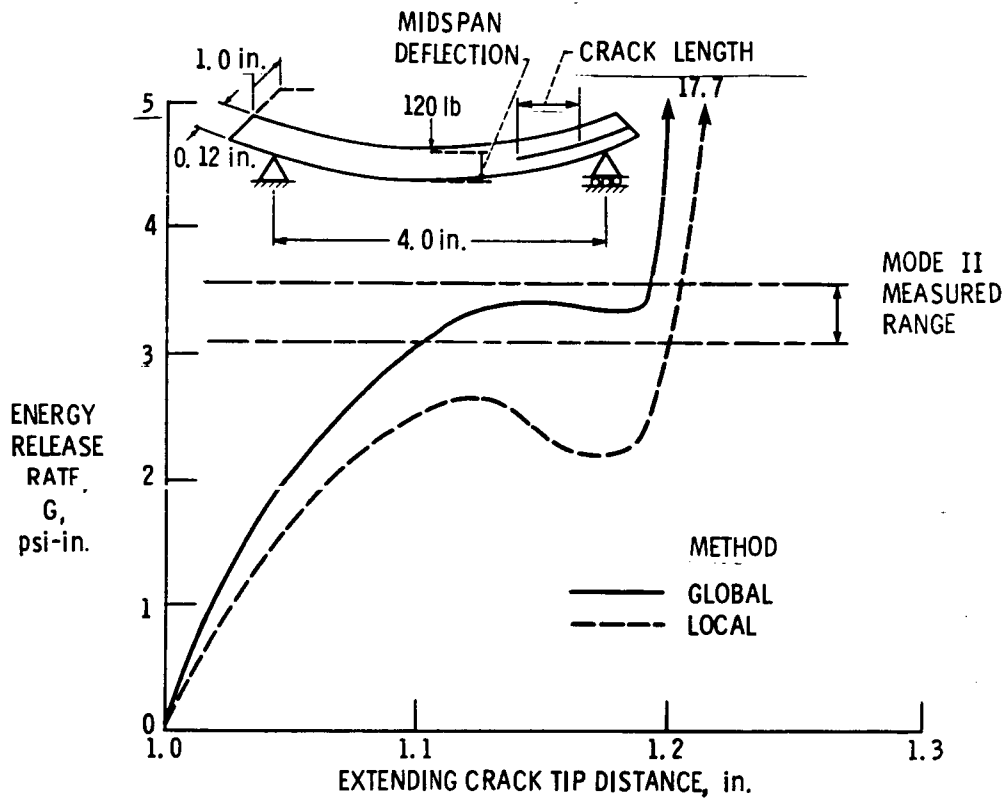

CD-88-32491

MIXED-MODE-FLEXURE ENERGY RELEASE RATE COMPARISONS

The global and local strain energy release rates are compared for the MMF specimen. From observing the local individual strain energy release rates it can be concluded that the crack growth is initiated by a mode II fracture, only to be dominated later by mode I growth. Also the sum of individual strain energy release rates G_I and G_{II} appears to be smaller than the total strain energy release rate G computed by global means.

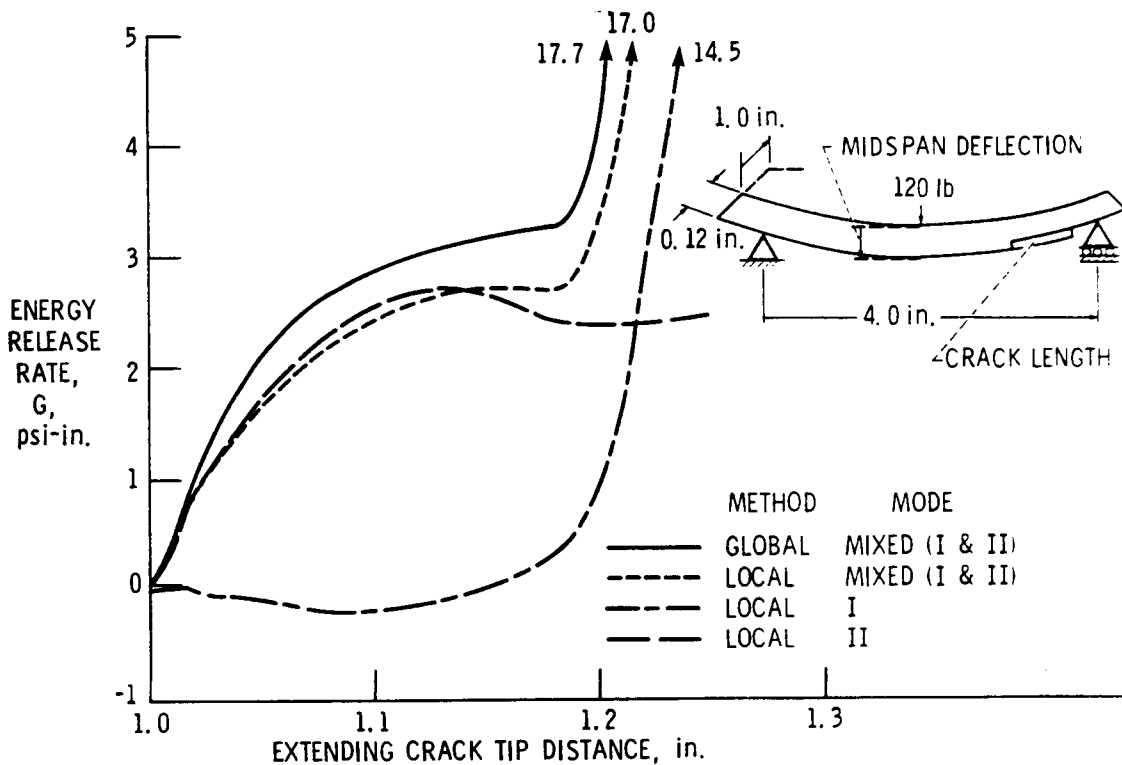

CD-88-32492

EFFECTS OF CRACK LENGTH AND PLY ORIENTATION ON STRAIN ENERGY RELEASE RATES

The mixed-mode-flexure specimen is modified by placing the crack plane off center and also by having all the $+\theta$ plies on one side of the crack plane and all the $-\theta$ plies on the other side. This ensures a component of the tearing mode (III) as well as the usual mode I and II components that are normally present in an MMF specimen. Results are presented for a family of laminate configurations. The tearing mode (III) content appears to have the smallest value of all the energy release rates attendant in this type of setup. In the figure below all release rates are in inch pounds per square inch.

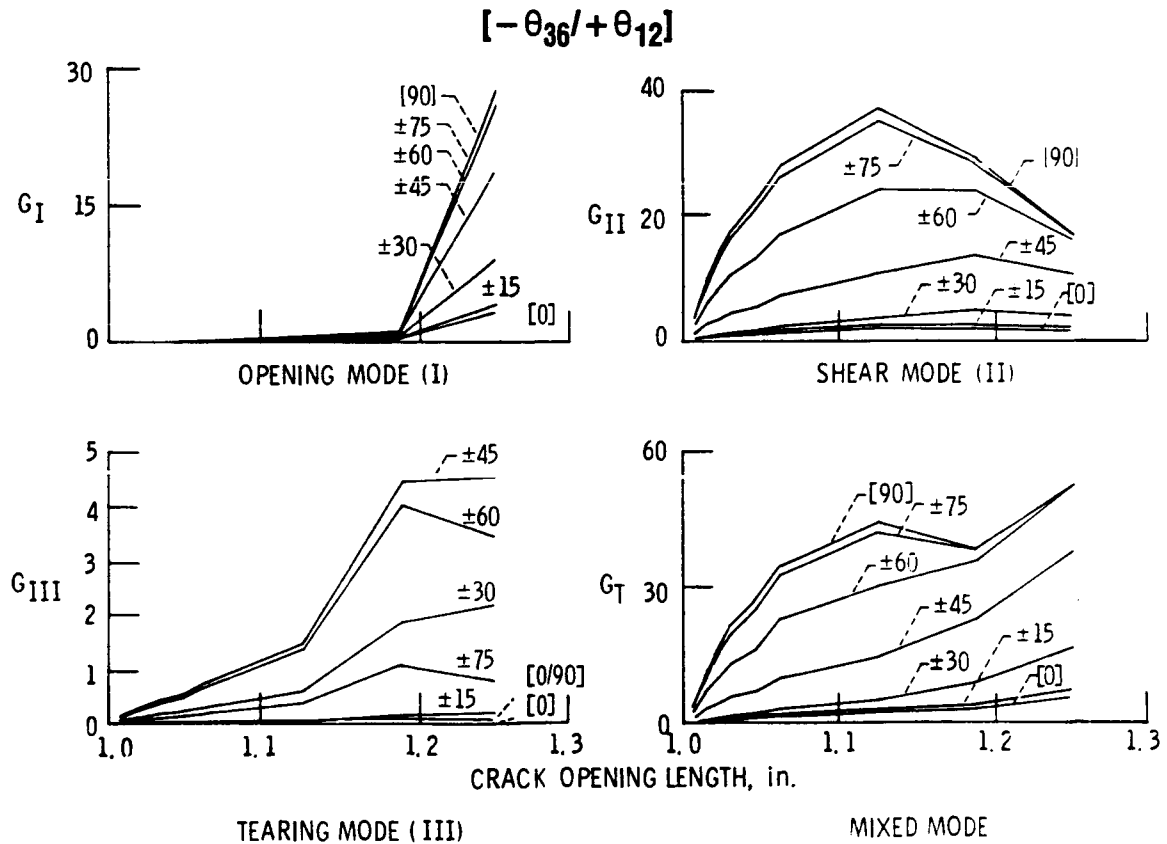

CD-88-32493

CONCLUSIONS

The important conclusions from the present study are listed below.

- COMPUTATIONAL SIMULATION METHODS ARE PRESENTED TO ASSESS PROGRESSIVE DAMAGE, CRACK GROWTH, AND FRACTURE TOUGHNESS CHARACTERISTICS.
- CODSTRAN PREDICTS AND PROVIDES QUANTITATIVE INFORMATION ON
 - FAILURE INITIATION
 - DEFECT GROWTH
 - DAMAGE AND THE VARIOUS SCALES IN WHICH IT OCCURS
- MSC/NASTRAN IS USED TO PREDICT
 - FRACTURE TOUGHNESS IN MODES I, II, AND III
 - GLOBAL AND LOCAL STRAIN ENERGY RELEASE RATES (SERR)
 - CRITICAL SERR AND THE ASSOCIATED CRACK LENGTH
- ALL THIS INFORMATION CAN BE USED IN DESIGNING COMPOSITE STRUCTURES. IT PROVIDES THE NECESSARY CONFIDENCE IN THEIR STRUCTURAL INTEGRITY, DURABILITY, AND DAMAGE TOLERANCE.

CD-86-32494

REFERENCES

- Chamis, C.C., and Smith, G.T., 1978, "CODSTRAN: Composite Durability Structural Analysis," NASA TM-79010.
- Chamis, C.C., 1986, "Computational Simulation of Progressive Fracture in Fiber Composites," NASA TM-87341.
- Ginty, C.A., 1985, "Progressive Damage, Fracture Predictions, and Postmortem Correlations for Fiber Composites," NASA TM-87101.
- Murthy, P.L.N., and Chamis, C.C., 1985, "Interlaminar Fracture Toughness: Three Dimensional Finite-Element Modeling for End-Notch and Mixed-Mode Flexure," NASA TM-87138.
- Murthy, P.L.N., and Chamis, C.C., 1986, "Composite Interlaminar Fracture Toughness: 3-D Finite Element Modeling for Mixed Mode I, II, and III Fracture," NASA TM-88872.