

N88 - 23240

**LOW-COST OPTICAL DATA ACQUISITION SYSTEM
FOR BLADE VIBRATION MEASUREMENT**

Stephen J. Posta
Structural Dynamics Branch
NASA Lewis Research Center

ABSTRACT

A low-cost optical data acquisition system was designed to measure deflection of vibrating rotor blade tips. The basic principle of the new design is to record in memory raw data (a set of blade arrival times) and to perform all processing by software after a run. This approach yields a simple and inexpensive system with much less hardware than required for an earlier design developed for this application.

Functional elements of the system were breadboarded and operated satisfactorily during rotor simulations on the bench and during a data collection run with a two-blade rotor in the Lewis spin rig.

Software was written to demonstrate the sorting and processing of data stored in the system control computer after retrieval from the data acquisition system. The demonstration produced an accurate graphical display of deflection versus time.

PRECEDING PAGE BLANK NOT FILMED

OVERVIEW

FEATURES

- **MEASURES DEFLECTION OF VIBRATING ROTOR BLADE TIPS.**
- **FACILITATES PROCESSING AND ANALYSIS BECAUSE DATA ARE DIGITAL.**
- **PROVIDES COMPLETE VIBRATION RECORDS FOR EACH ROTOR BLADE.**
- **ELIMINATES CALIBRATION PROBLEMS INHERENT TO STRAIN GAGE SYSTEMS.**

CD-88-31874

FUNCTIONAL ELEMENTS

- **FIXED OPTICAL PROBES SENSE BLADE PASSAGE.**
- **DATA ACQUISITION BOARDS RECEIVE AND STORE NEW DATA (A SET OF BLADE ARRIVAL TIMES).**
- **A CONTROL COMPUTER SORTS AND PROCESSES DATA INTO USABLE FORM.**
- **A CONTROL BOARD PROVIDES THE INTERFACE BETWEEN DATA ACQUISITION BOARDS AND THE CONTROL COMPUTER.**

CD-88-31875

OPTICAL DATA ACQUISITION SYSTEM

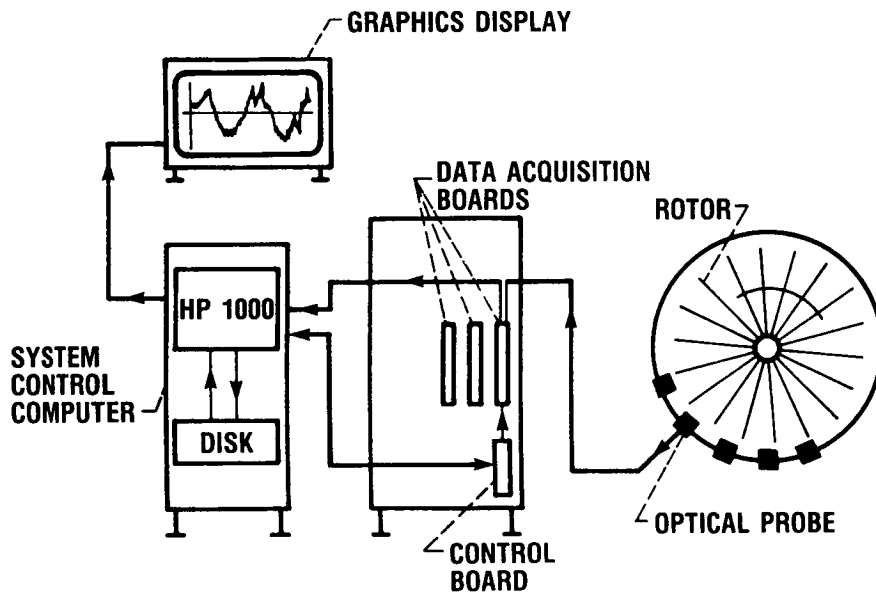

CD-88-31876

POSTER PRESENTATION

OPTICAL DATA ACQUISITION SYSTEM

The optical data acquisition system comprises a set of fixed optical probes that sense blade passage, data acquisition boards that receive and store in memory the raw data (a set of blade arrival times), a control computer that sorts the data into a usable form after each data collection run, and a control board that provides the interface between the data acquisition boards and the control computer.

Design details for this system are reported in Posta and Brown (1986). A relatively more complex and costly earlier design was described in Brown et al. (1984) and Lawrence and Meyn (1984).

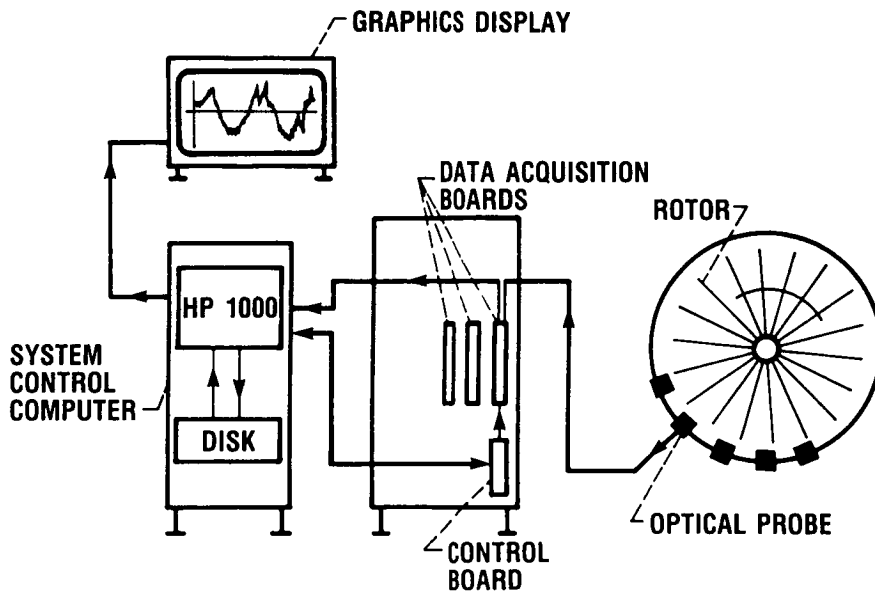

CD-88-31876

OPTICAL PROBE

Each probe contains a high-resolution optical, reflective sensor and associated support electronics. The sensor is a focused light-emitting diode (LED) and matched photodetector in a single package. A visible light beam emitted by the LED is focused at the blade tips. As a blade edge passes by the probe at high speed, the event is detected, converted to a transistor-transistor logic (TTL)-compatible signal, and sent to a data acquisition board, where it is stored in memory.

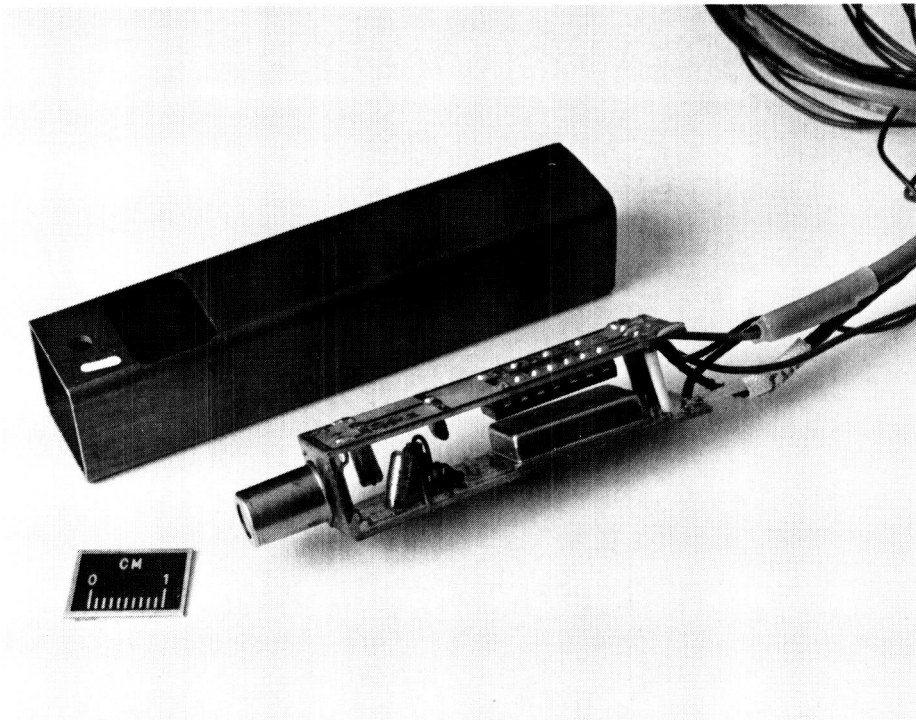

CD-88-31877

ORIGINAL PAGE IS
OF POOR QUALITY

OPTICAL PROBE INSTALLATION IN SPIN RIG

A probe assembly containing three optical probes is located at each of 16 viewing ports equally spaced around the perimeter of the spin rig case. One probe monitors the position of the blade tip leading edge, another monitors the blade tip midchord, and the third monitors the blade tip trailing edge. In this manner bending, torsion, and camber vibration modes can be identified. A single additional probe senses the start of each revolution with the passage of a timing mark on the rotor shaft.

ORIGINAL PAGE IS
OF POOR QUALITY

OPTICAL PROBE ASSEMBLY

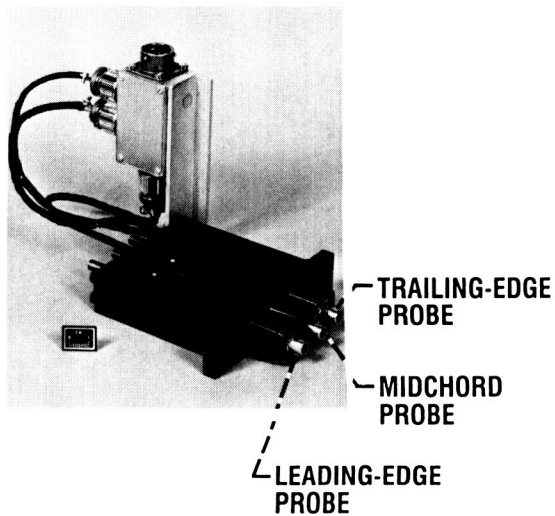

OPTICAL PROBE INSTALLATION IN SPIN RIG

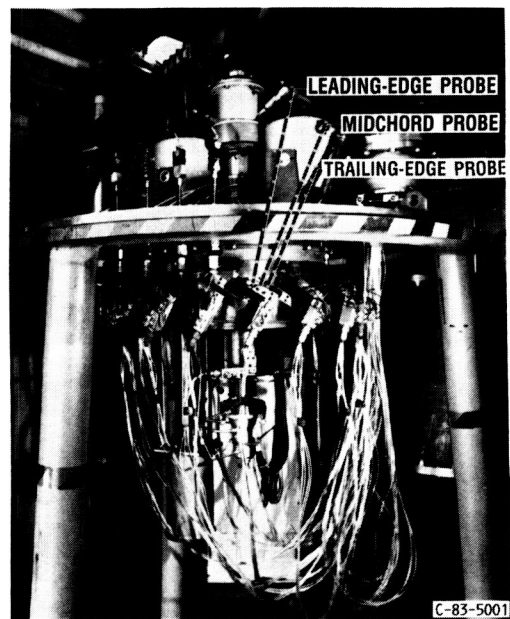

CD-88-31878

DATA ACQUISITION BOARD MEMORY LOGIC

Blade detection pulses from a probe correspond to blade arrival times measured from the start of each data collection run. These pulses latch the count from a high-speed wraparound counter located on the system control board and begin writing the count into the current memory address. In this manner the blade arrival times are "time stamped" into memory.

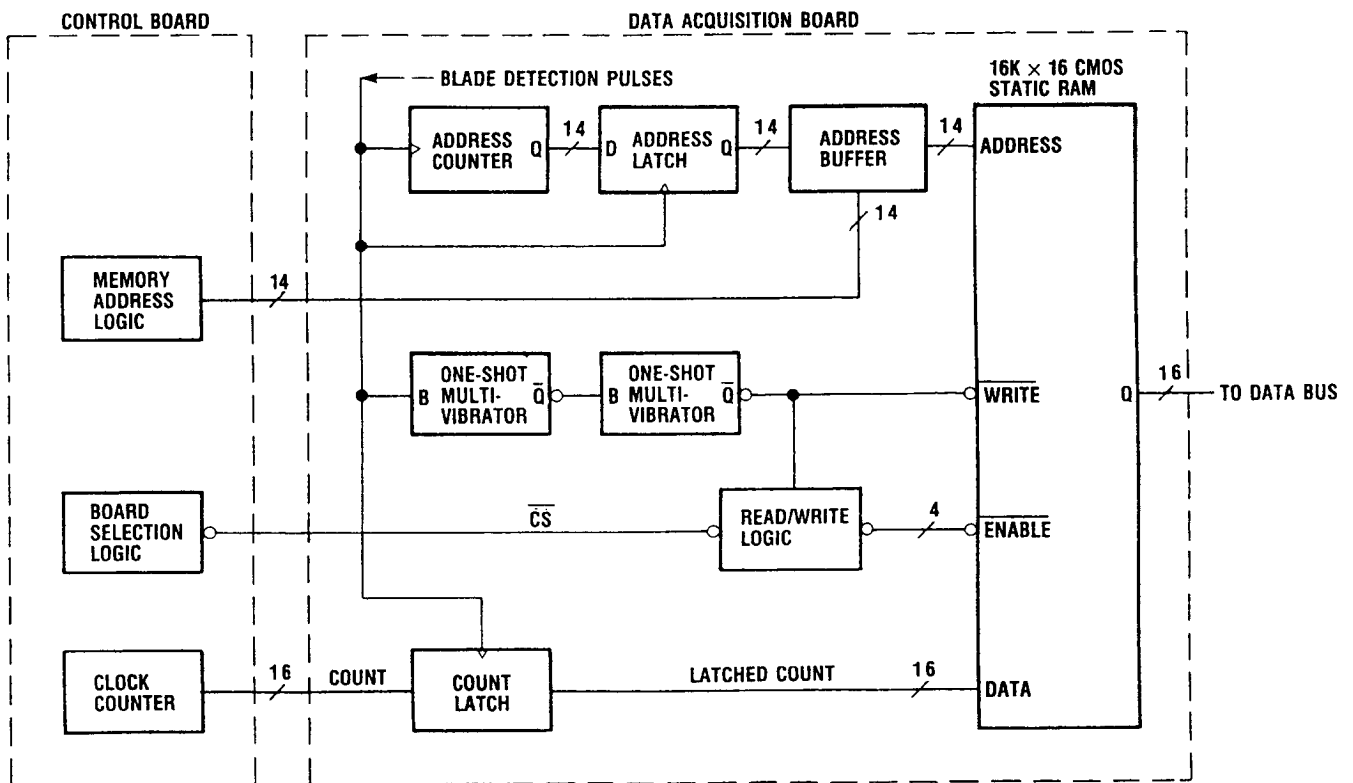

CD-88-31879

DATA ACQUISITION BOARD INPUT CIRCUIT

A system with fewer data acquisition boards and fewer components can be designed if each board accepts data from more than one optical probe. This is possible because the pulses from any probe are relatively widely spaced in time, in contrast to the temporal variation of any pulse due to blade vibration. The signals from one or more other probes can be interspersed if a known ordering of the pulses is maintained. This approach does not reduce the total memory size but saves substantial duplication of other components, such as counters and latches. A board configuration having four optical probe inputs was chosen because it allows a maximum deflection of 140 mils, which exceeds the performance of the earlier designed system in this area.

One pair of probes (viewing ports 0 and 2) is separated from the other pair (viewing ports 4 and 6) by input gates G1 and G2. This allows optional delay to be added to signals from one probe pair. The signals from both probe pairs are combined at output gate G3 and appear at the output of this gate as a composite train of interspersed blade deflection pulses. Depending on the rotor configuration, delay may be required to separate probe signals that are coincident or overlap in time.

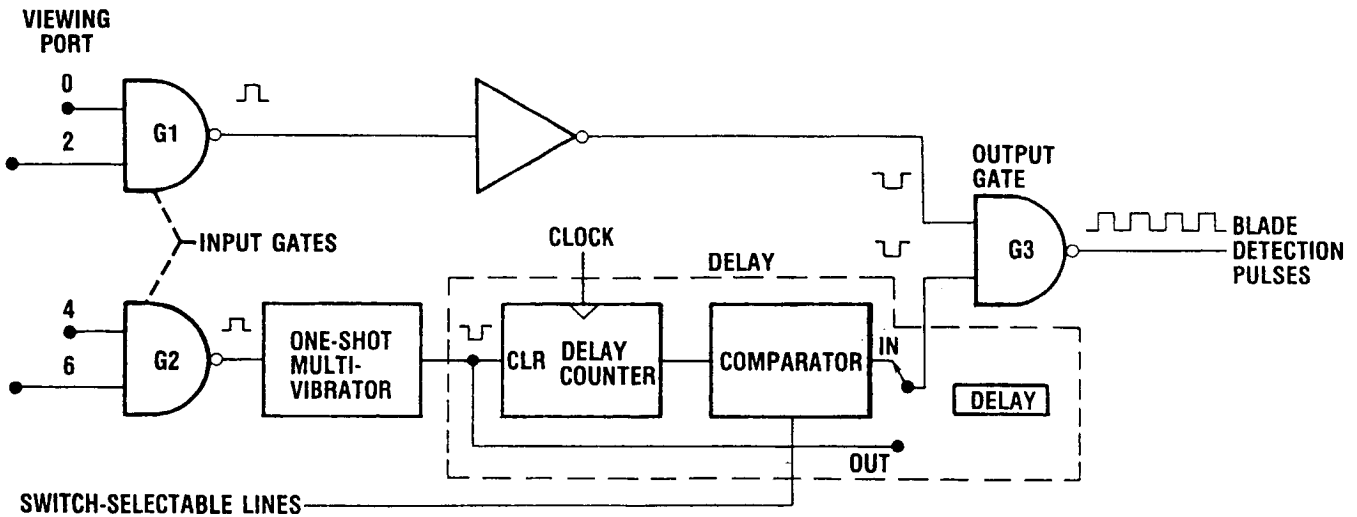

CD-88-31880

CONTROL BOARD

The control board has control circuits for interfacing the data acquisition boards with an external computer during the acquisition, storage, and retrieval phases of a data collection run. A section of the board records the time when each rotor revolution begins, as monitored by a separate optical probe. This information is used in measuring rotor speed. The master clock and high-speed wraparound counter are also located on this board.

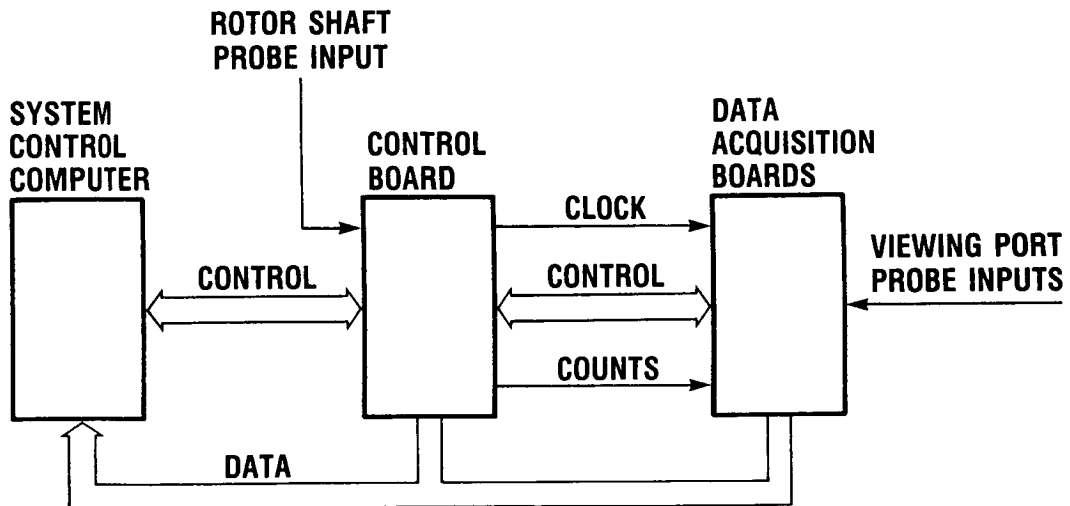

CD-88-31881

COMPARISON OF SYSTEMS

The low-cost system retains the important performance characteristics of an earlier designed system. Maximum allowable blade tip deflection, deflection resolution, maximum (unaliased) frequency, and frequency resolution are equal to or better than those of an earlier designed system. The low-cost system requires fewer circuit boards, each with a significantly reduced component count than previous designs.

The need for frequency synthesizers is eliminated by "time stamping" the blade arrival times measured from the start of a data collection run rather than those measured from the start of each revolution.

MAXIMUM ALLOWABLE BLADE TIP DEFLECTION AND DEFLECTION RESOLUTION

ROTOR DIAMETER, 20 in.

SYSTEM	NUMBER OF ROTOR BLADES	ROTATIONAL SPEED, rpm	MAXIMUM ALLOWABLE DEFLECTION, ± mil	DEFLECTION RESOLUTION, mil
EARLIER DESIGN	ANY NUMBER	15 000 3 000	*102 TO 1257 *102 TO 1257	*0.8 TO 9.8 *0.8 TO 9.8
LOW-COST DESIGN	56 2	15 000	140	0.80
		3 000	140	.16
		15 000	3927	.80
		3 000	3927	.16

*CAN BE SET OVER THIS RANGE BY SOFTWARE CHANGE OF SYNTHESIZER FREQUENCY.

CD-88-31862

SYSTEM CHARACTERISTICS

56 BLADES, 15 000 rpm

SYSTEM CHARACTERISTICS	SYSTEM	
	EARLIER DESIGN	LOW-COST DESIGN
MEMORY SIZE PER BOARD	4096 8-BIT WORDS	16 384 16-BIT WORDS
NUMBER OF DATA BOARDS	16	4
SAMPLE TIME, μ sec	250	250
(TIME FOR BLADE n TO GET FROM PORT n TO PORT $(n+2)$)		
SAMPLE RATE, f, Hz	4000	4000
MEMORY PER BLADE, (MEMORY SIZE \times NUMBER OF BOARDS) NUMBER OF BLADES	1170 WORDS	1170 WORDS
TIME TO FILL MEMORY, τ , sec, (MEMORY PER BLADE) SAMPLE RATE	0.292	0.292
FREQUENCY RESOLUTION, $1/T$, Hz	3.42	3.42
MAXIMUM UNALIASSED FREQUENCY, $f/2$, Hz	2000	2000

CD-88-31863

HARDWARE REQUIREMENTS

REQUIREMENT	SYSTEM	
	EARLIER DESIGN	LOW-COST DESIGN
DATA ACQUISITION BOARDS		
TOTAL NUMBER OF BOARDS, (PORTS \times PROBES PER PORT) PROBES PER BOARD	$\frac{16 \times 2}{1} = 32$	$\frac{16 \times 2}{4} = 8$
IC's PER BOARD	68	30
TOTAL IC's	2178	240
CPU	$32 \times 1 = 32$	0
FIFO	$32 \times 1 = 32$	0
EPROM	$32 \times 2 = 64$	0
DRAM	$^a 32 \times 8 = 256$	0
SRAM	$32 \times 2 = 64$	$^b 8 \times 4 = 32$
CONTROL BOARD		
NUMBER OF BOARDS	2	1
IC's PER BOARD	BOARD 1, 97; BOARD 2, 44	43
TOTAL IC's	141	43
FREQUENCY SYNTHESIZER	2	NONE

^aTOTAL MEMORY, 1 MEGABIT
^bTOTAL MEMORY, 2 MEGABITS

CD-88-31864

REFERENCES

- Brown, G.V., et al., 1984, "Lewis Research Center Spin Rig and Its Use in Vibration Analysis of Rotating Systems." NASA TP-2304.
- Lawrence, C., and Meyn, E.H., 1984, "The Use of an Optical Data Acquisition System for Bladed Disk Vibration Analysis." NASA TM-86891.
- Posta, S.J., and Brown, G.V., 1986, "A Low-Cost Optical Data Acquisition System for Vibration Measurement." NASA TM-88907.