

N88-23247

AEROELASTIC FORCED RESPONSE ANALYSIS OF TURBOMACHINERY*

Todd E. Smith
Sverdrup Technology, Inc.
(Lewis Research Center Group)
NASA Lewis Research Center

ABSTRACT

The Structural Dynamics Branch is currently involved in the development of predictive tools for application to vibration problems within engine structures. This brief article outlines the research activity currently under way to predict the aeroelastic forced response of fan, compressor, and turbine components.

There are currently no analytical methods for predicting the forced response behavior of turbomachinery components. Traditionally, the blade Campbell diagram has been used to determine if a resonant frequency will interfere with an engine order excitation. This technique has proven very successful over the past few decades, but the push for higher stage loading and lighter engine weight raises many forced response problems. The goal of this new research is to create a system which will enable a designer to analytically predict fan, compressor, and turbine blade response due to the many inherent sources of excitation.

The Forced Response Prediction System (FREPS) is being created as an analytical tool for turbomachinery forced response. This system combines many of the traditional structural and aeroelastic system models with the more recent advanced unsteady aerodynamic models. The initial emphasis of this project is to develop methods for predicting unsteady blade loads due to flow field disturbances which result within rotating blade rows.

The use of advanced computational aerodynamic models is enabling the prediction of motion-independent airfoil unsteady loads which occur due to aerodynamic excitations. For example, the aerodynamic loads induced by viscous wake passing and downstream potential-field fluctuations can now be predicted by using these computational fluid dynamic codes.

The application of advanced unsteady aerodynamics codes also permits the prediction of the motion-dependent, unsteady blade loads which occur within complex (thick, highly cambered) blade passages. This capability allows for the estimation of the unsteady pressure field within oscillating turbine blade cascades at a variety of flow Mach numbers.

*Work performed on-site at the Lewis Research Center for the Structural Dynamics Branch under contract NAS3-24105.

An initial application of this predictive system is to determine the aeroelastic behavior of the space shuttle main engine (SSME) oxygen pump turbine blades. These blades have had a history of fatigue failures, and the aerodynamic loads caused by the turbine vanes, struts, and cooling jets may be contributing to the high vibratory stresses.

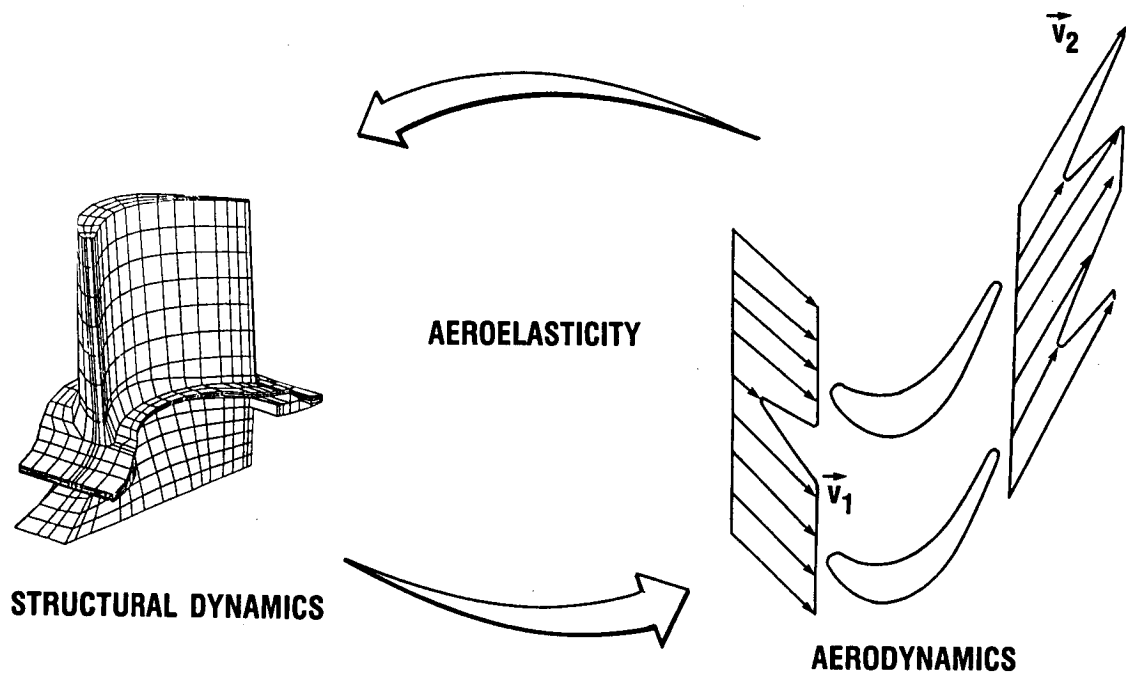

CD-88-31809

AEROELASTIC PHENOMENA

The aeroelastician is concerned with the manner in which elastic structures respond when placed within a flowing fluid. In particular, the stability and forced response of the structure must be determined. Stability problems are generally not encountered within turbomachinery because this is usually a constraint during initial design studies. Forced response is typically a long-term problem because there are presently no useful design tools available.

Aeroelastic stability of a structure is assured if there are no unstable self-excited vibratory modes present at the standard operating conditions. The presence of sufficient aerodynamic damping within an oscillating cascade of blades will determine if stable or unstable motion results.

The aeroelastic forced response analysis attempts to predict the manner (displacements, phase relationships) in which the structure responds to flow field disturbances.

BLADE CAMPBELL DIAGRAM

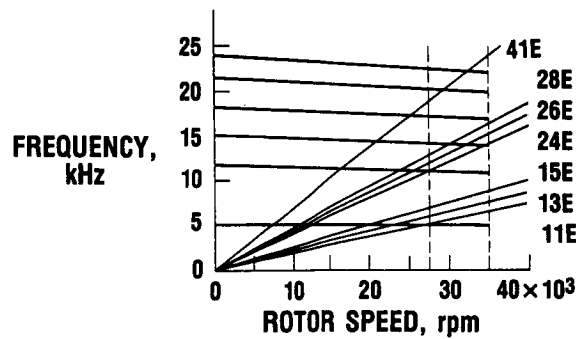

BLADE FORCED RESPONSE

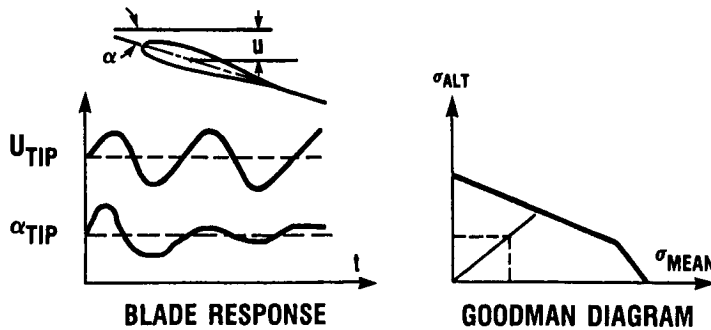

CD-88-31810

TURBOMACHINERY FORCED RESPONSE - TRADITIONAL METHODS

The frequency-speed behavior of turbomachinery blades is customarily used to determine if a forced response problem may exist for the component. The operating line interferences with resonant blade frequencies and engine order excitations in a Campbell diagram are used to make a yes or no decision about forced response problems. An example of such a determination is demonstrated in Moss and Smith (1987). This traditional approach does not predict the actual blade response to such excitations, but it does give an indication of the possibility of having a significant blade response.

This research will provide a forced response calculation procedure which will estimate the magnitude and phase of blade motion induced by the flow field disturbances. Knowledge of the airfoil forced response may then be used to infer magnitude of vibratory stresses and fatigue characteristics through application of standard Goodman diagram techniques.

AEROELASTIC EQUATION OF MOTION

$$\underbrace{M\ddot{q} + C\dot{q} + Kq}_{\text{STRUCTURAL MODEL}} = \underbrace{A(q,t)}_{\text{MOTION-DEPENDENT AERODYNAMIC LOADS}} + \underbrace{F(t)}_{\text{MOTION-INDEPENDENT AERODYNAMIC LOADS}}$$

FORCED RESPONSE PREDICTION SYSTEM - FREPS

The FREPS system couples the aeroelastic equations of motion for a cascaded blade row. This system uses the aeroelastic system models developed during the last decade and the advanced aerodynamic models developed more recently.

A general aeroelastic equation of motion is presented below. This equation models the structural characteristics of the system (left-hand side) along with the forcing function (right-hand side). The structural characteristics may include structural damping, mistuning, etc. The forcing functions are due to two sources: motion-dependent forces and motion-independent, flow-induced forces.

The FREPS system uses unsteady aerodynamic analysis to predict the motion-dependent forces in complex blade passages. This system also uses empirical models and correlations to define the influence of the motion-independent aerodynamically induced loads.

AERODYNAMIC EXCITATIONS

- UPSTREAM; VISCOUS WAKE SHEDDING
- DOWNSTREAM, POTENTIAL FIELD DISTURBANCES
- BLADE SECONDARY FLOW PHENOMENA
- COMPRESSOR SURGE/ ROTATING STALL
- INLET FLOW FIELD DISTORTION-TURBULENCE

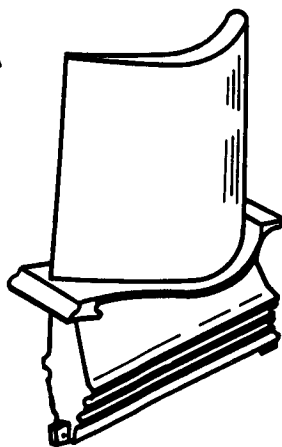

MECHANICAL EXCITATIONS

- BLADE TIP-CASING CONTACT
- ROTOR DISK FLEXIBILITY
- SHAFT AND GEAR MESH EXCITATIONS
- FOREIGN OBJECT DAMAGE



CD-88-31812

SOURCES OF UNSTEADY BLADE LOADS

The typical rotating turbine blade is subjected to many mechanical and aerodynamic forcing functions. Mechanical vibrations may be transmitted through the supporting structures (disk, bearings, etc.) to result in unsteady blade loads.

Aerodynamic unsteadiness due to the aerodynamic interaction within a rotor-stator pair generates significant unsteady loads. Unlike the mechanical sources which may occur during specific portions of operation, the aerodynamic forcing functions are always present. This research is chiefly concerned with developing methods to estimate the effect of these aerodynamically induced unsteady loads on blade response.

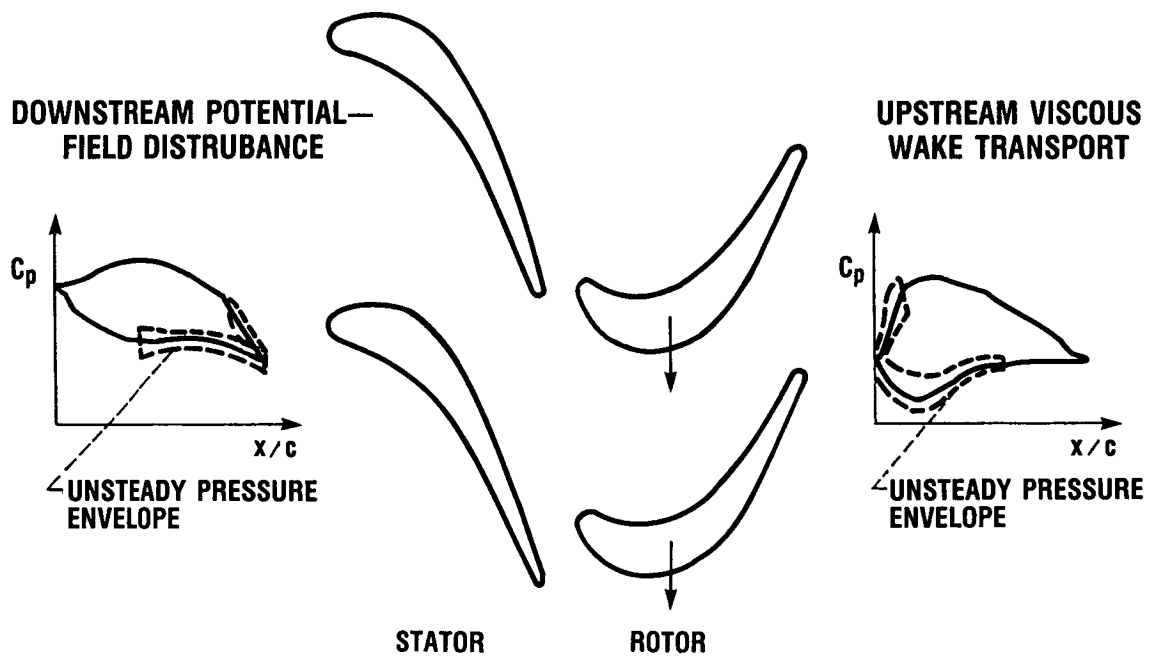

CD-88-31813

UNSTEADINESS DUE TO AERODYNAMIC INTERACTION

The presence of adjacent rotating and stationary blade rows is inherently a source of complex, nonsteady flow conditions. Two of the more dominant aerodynamic interaction effects are due to the viscous wake shedding and the pressure-field interaction problem. A complete experimental study of these two interaction effects has been reported by Dring et al. (1982).

The upstream blade row generates a viscous wake flow disturbance which is convected downstream to a blade row moving relative to the wake. As the wake passes through the downstream blade passage, it distorts and causes unsteady surface pressures, which lead to unsteady loads. The wake shedding influence may persist far downstream within the machine.

The aft blade row represents a blockage to the primary flow field, which causes a fluctuation in the pressure field. This pressure field unsteadiness affects the flow characteristics within the upstream blade row. The influence of the pressure field interaction diminishes rapidly as the axial spacing is increased.

STEADY MEAN FLOW ANALYSIS

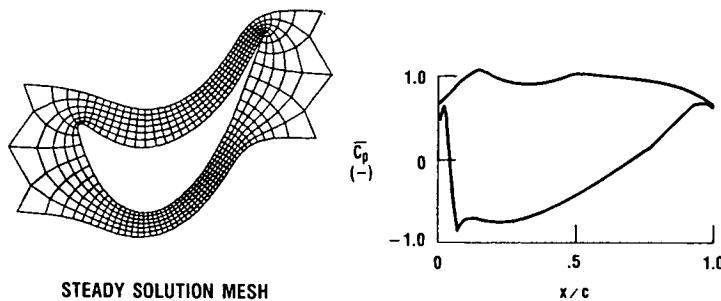

LST 88

UNSTEADY OSCILLATORY FLOW ANALYSIS

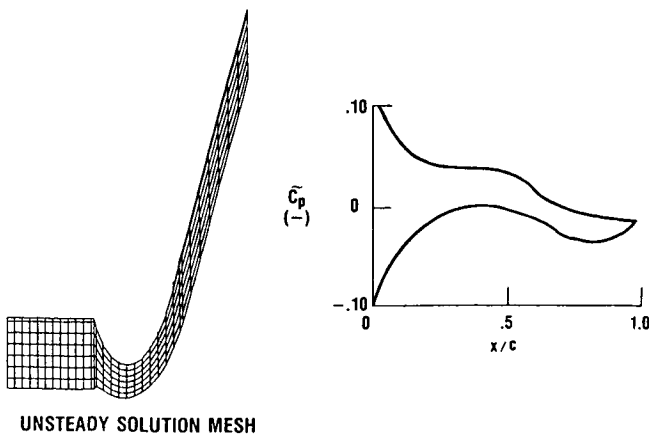

CD-88-31829

UNSTEADY BLADE LOADS

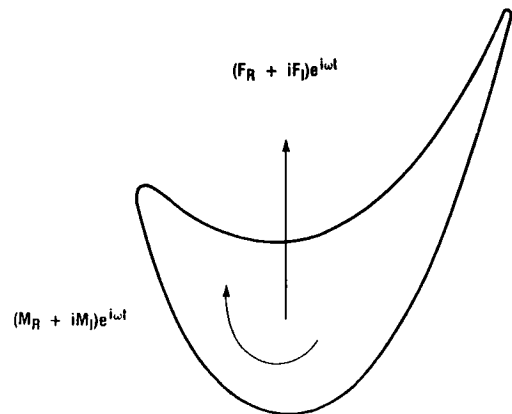

CD-88-31830 LST 88

UNSTEADINESS DUE TO OSCILLATING BLADE MOTION

The traditional small-disturbance strip theories are not applicable for predicting the unsteady flow in thick, cambered turbine blade passages. Newly developed aerodynamic tools (Verdon and Caspar, 1984) are being used to predict the steady and unsteady pressures and loads caused by turbine blade airfoil oscillations. These aerodynamic models allow for the prediction of unsteady flow behavior over a range of subsonic and transonic flow conditions.

CASCADE MODEL

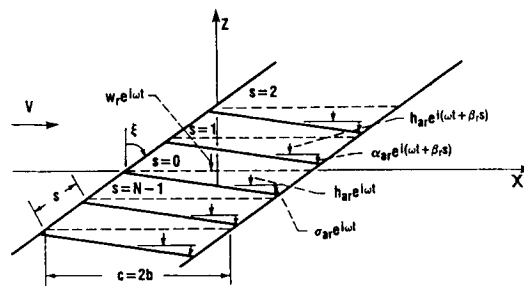

LST 88

CD-88-31894

FINITE ELEMENT MODAL ANALYSIS

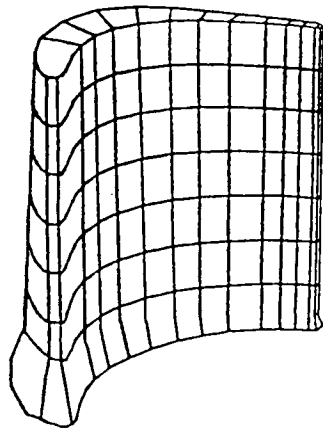

CD-88-31893

2-DOF OSCILLATOR

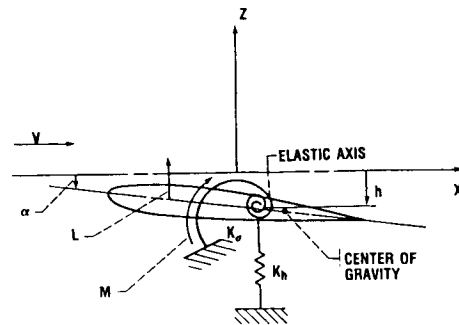

CD 88 31815

AEROELASTIC SYSTEM MODELS

The modeling techniques for the structural response of the system to the aerodynamic excitation is based on a wide range of structural models ranging from simple two-DOF lumped parameter models, to cascaded blade models, up to highly refined finite-element modal analysis techniques. Example applications of these aeroelastic models have been presented by Kielb and Kaza (1982) and Kaza et al. (1987).

- **FREPS SYSTEM COUPLES AEROELASTIC, UNSTEADY AERODYNAMIC, AND FORCING FUNCTION MODELS**
- **EMPHASIS ON DEVELOPMENT OF CORRELATIONS TO MODEL AERODYNAMIC FORCING FUNCTIONS**
- **ADVANCES IN CFD ARE REQUIRED TO BETTER MODEL AERODYNAMIC INTERACTION BETWEEN BLADE ROWS**

CD-88-31895

SUMMARY

An introduction has been presented to the research activity under way to enable the prediction of turbomachinery aeroelastic forced response. An effort is being made to assemble a computer program (FREPS) which incorporates the aeroelastic structural models, unsteady aerodynamic models, and forcing function models. The structural and aerodynamic models are currently well developed. The forcing function models are currently at a primitive level.

A significant activity has begun to identify the forcing functions due to stator-rotor aerodynamic interaction. This is a formidable task which requires the use of advanced computational fluid dynamic programs. The results from these CFD predictions will be combined into "semiempirical" correlations which are more amenable for inclusion within the aeroelastic analysis models.

REFERENCES

- Dring, R.P., Joslyn, H.D., Hardin, L.W., and Wagner, J.H., 1982, "Turbine Rotor-Stator Interaction," *Journal of Engineering for Power*, Vol. 104, p. 729.
- Kaza, K.R.V., Mehmed, O., Narayanan, G.V., and Murthy, D.V., 1987, "Analytical Flutter Investigation of a Composite Propfan Model," AIAA Paper 87-0738, Presented at the AIAA/ASME/ASEE/AHS 28th Structures, Structural Dynamics, and Materials Conference, Monterey, CA.
- Kielb, R.E., and Kaza, K.R.V., 1982, "Aeroelastic Characteristics of a Cascade of Mistuned Blades in Subsonic and Supersonic Flows," *Journal of Vibration, Acoustics, Stress, and Reliability in Design*, Vol. 105, p. 425.
- Moss, L.A., and Smith, T.E., 1987, "SSME Single Crystal Turbine Blade Dynamics," NASA CR-179644.
- Verdon, J.M., and Caspar, J.R., 1984, "A Linear Aerodynamic Analysis for Unsteady Transonic Cascades," NASA CR-3833.