

NASA Contractor Report 4133

Final Report on the Near-Real-Time TOMS, Telecommunications, and Meteorological Support for the 1987 Airborne Antarctic Ozone Experiment

P. Ardanuy, J. Victorine, F. Sechrist,
A. Feiner, L. Penn, and the RDS Airborne
Antarctic Ozone Experiment Team

CONTRACT NAS5-29373
APRIL 1988

NASA

NASA Contractor Report 4133

**Final Report on the Near-Real-Time
TOMS, Telecommunications, and
Meteorological Support for
the 1987 Airborne Antarctic
Ozone Experiment**

**P. Ardanuy, J. Victorine, F. Sechrist,
A. Feiner, L. Penn, and the RDS Airborne
Antarctic Ozone Experiment Team**
*Research and Data Systems Corporation
Greenbelt, Maryland*

Prepared for
Goddard Space Flight Center
under Contract NAS5-29373



National Aeronautics
and Space Administration

Scientific and Technical
Information Division

1988

The RDS Airborne Antarctic Ozone Experiment Team:

Mohammed Alizadeh

Philip Ardanuy

David Bolvin

Albert Feiner

Steven Gaines

Susan Krupa

Dave Larko

Segun Park

Lanning Penn

Frank Sechrist

Ransome Smith

Brenda Vallette

James Victorine

Forrest Wheat

TABLE OF CONTENTS

<u>Section</u>	<u>Page</u>
1. INTRODUCTION	1
1.1 The 1987 Antarctic Ozone Hole Experiment . . .	1
1.2 Requirements	4
1.3 The Nimbus-7 Total Ozone Mapping Spectrometer .	5
1.4 Meteorological Analysis Support and Available Technical Resources	7
2. TELECOMMUNICATIONS NETWORK DESIGN	9
2.1 Overview	9
2.2 ECMWF Berkshire	11
2.3 UKMO Bracknell	11
2.4 RDS/NASA Communication Center: Punta Arenas . .	11
2.5 RDS/NASA Communication Center: Cape Horn Hotel	12
2.6 Goddard Space Flight Center	12
2.7 Operation of the System	13
3. INSTALLATION OF THE TELECOMMUNICATIONS NETWORK . . .	14
3.1 Schedule	14
3.2 Ordering the Telecommunication Lines and Equipment	14
3.3 Timely Shipping	14
3.4 Equipment Installation.	17
3.5 Network Testing	17
4. NETWORK OPERATIONS	18
4.1 Communications Watch	19
4.2 Patch Panel	19
4.3 Facsimile	20
4.4 Trouble Ticket.	21
4.5 Hotel Communication Center.	25
4.6 Problems	25
4.7 Termination	26
5. TOMS DATA PREPARATION AND TRANSFER	26
5.1 Data Available to Punta Arenas	26
5.2 Utilization of the Near-Real-Time Telecommunications Network	28
5.3 Data Analysis and Presentation	31
6. TOMS TOTAL OZONE DATA	35
6.1 Chronology of the Experiment	35
6.2 Latitudinal Cross-Sections	40
6.3 Time Series at Locations of Interest	41

TABLE OF CONTENTS (continued)

<u>Section</u>	<u>Page</u>
6.4 Near-Real-Time Orbital Charts	59
6.5 Southern Hemispheric Polar Charts	59
7. PRELIMINARY ANALYSIS OF THE 1987 OZONE HOLE BASED ON TOMS DATA	70
7.1 Preconditions to the Formation of the Hole	70
7.2 Initiation of the Hole	72
7.3 Maturity of the Hole	82
7.4 Dissolution of the Hole	106
8. CONCLUSIONS AND DISCUSSIONS	111
8.1 Timely Requirements Definition	111
8.2 Understanding Lead Times	112
8.3 Dealing with Foreign Carriers	112
8.4 Equipment Interfaces	113
8.5 Rolm CBX-9000	115
8.6 Engineering Compromises	115
8.7 Manning Participating Sites Twenty-Four Hours a Day	116
8.8 Value of the Communications Patch Panel	117
8.9 Assigning Responsibility for Communications to the Contractor	117
8.10 Keeping Management Informed	118
8.11 Timely Coordination	118
8.12 The Importance of Communications	119
8.13 Some Lessons Learned in Dealing with Smaller Nations	120
9. REFERENCES	121
ACKNOWLEDGEMENTS	124

LIST OF FIGURES

<u>Figure</u>		<u>Page</u>
1a	A Time History of the Minimum Ozone Values Recorded by the Nimbus-7 TOMS over the Last Nine Years	2
1b	A schematic representation of the Nimbus-7 spacecraft overflying the south pole. The TOMS total ozone is portrayed topographically here, with the Antarctic ozone hole clearly evident .	3
2	The design of the 1987 Airborne Antarctic Ozone Experiment telecommunications network	10
3	Milestone chart for the performance of the various aspects of support of the 1987 Airborne Antarctic Ozone Experiment	15
4	A sample page (page 37) of the facsimile log, illustrating the volume of traffic over a portion of September 6 and 7 during the experiment . .	22
5	A sample facsimile reception report summarizing 35 transmissions, which included 321 pages of data, during 18 hours of September 19	23
6	A sample trouble ticket illustrating the notification and follow-up processing accompanying a noise-level problem	24
7	Timely notification of an unforeseen communications problem	27
8	Subsatellite tracks produced from predictive ephemeris for orbit 44500-1 on August 17, 1987.	29
9	Real-time TOMS data flow and transfer during the 1987 Airborne Antarctic Ozone Experiment . . .	30
10	A sample of TOMS total ozone observations from portions of 36 scan lines during orbit 44500 of August 17, 1987	33
11	Objectively analyzed TOMS total ozone data obtained from measurements taken during orbit 44500-1	34
12a-b	Cross-sections of TOMS total ozone measurements along the 70°W and 110°E longitudes across the south pole for four periods during (a) August 1987 and (b) September 1987	42

LIST OF FIGURES (continued)

<u>Figure</u>		<u>Page</u>
12c-d	Cross-sections of TOMS total ozone measurements along the 70°W and 110°E longitudes across the south pole for (c) four periods during October 1987 and (d) October 5, 1987	43
13a	Daily TOMS Total Ozone Values over Punta Arenas	49
13b	Daily TOMS Total Ozone Values over Marambio . .	50
13c	Daily TOMS Total Ozone Values over Palmer Station	51
13d	Daily TOMS Total Ozone Values over Dumont D'Urville	52
13e	Daily TOMS Total Ozone Values over Molodeznaya Station	54
13f	Daily TOMS Total Ozone Values over Syowa . . .	55
13g	Daily TOMS Total Ozone Values over Davis . . .	56
13h	Daily TOMS Total Ozone Values over Halley Bay .	57
13i	Daily TOMS Total Ozone Values over McMurdo . .	58
13j	Daily TOMS Total Ozone Values over Vostok . . .	60
13k	Daily TOMS Total Ozone Values over Amundsen-Scott	61
14a	Orbital TOMS Near-Real-Time Total Ozone Observations for August 17, 1987	62
14b	Orbital TOMS Near-Real-Time Total Ozone Observations for September 5, 1987	63
14c	Orbital TOMS Near-Real-Time Total Ozone Observations for September 18, 1987	64
14d	Orbital TOMS Near-Real-Time Total Ozone Observations for September 28, 1987	65
15a	TOMS Near-Real-Time Total Ozone Measurements over the Southern Hemisphere on August 5, 1987 . . .	66
15b	TOMS Near-Real-Time Total Ozone Measurements over the Southern Hemisphere on September 16, 1987 .	67

LIST OF FIGURES (continued)

<u>Figure</u>		<u>Page</u>
15c	TOMS Near-Real-Time Total Ozone Measurements over the Southern Hemisphere on October 5, 1987 . . .	68
15d	TOMS Near-Real-Time Total Ozone Measurements over the Southern Hemisphere on October 11, 1987 . . .	69
16	TOMS Ozone Distribution for the Southern Hemisphere on August 24, 1987	71
17	ECMWF 70 mb analysis for August 24, 1987 . . .	73
18	70 mb Temperature Advection for August 24, 1987	74
19	Orbital TOMS Ozone Contours for August 16, 1987 (orbits 44485-44488)	76
20a	Orbital TOMS Ozone Contours for August 16, 1987 (orbit 44486)	77
20b	Orbital TOMS Ozone Contours for August 16, 1987 (orbit 44487)	78
21a	TOMS Ozone Distribution for the Southern Hemisphere on September 5, 1987	79
21b	TOMS Ozone Distribution for the Southern Hemisphere on September 8, 1987	80
21c	TOMS Ozone Distribution for the Southern Hemisphere on September 15, 1987	81
22a	Orbital TOMS Ozone Contours for August 26, 1987 (orbits 44623-44625)	83
22b	Orbital TOMS Ozone Contours for August 29, 1987 (orbits 44665-44667)	84
23a	Halley Bay Vertical Soundings of Ozone Partial Pressure and Temperature for August 26, 1987 .	85
23b	Halley Bay Vertical Soundings of Ozone Partial Pressure and Temperature for August 29, 1987 .	86
24	Palmer Station Vertical Sounding of Ozone Partial Pressure for October 9, 1987	87
25a	Palmer Station Vertical Sounding of Ozone Partial Pressure on September 18, 1987	88

LIST OF FIGURES (continued)

<u>Figure</u>		<u>Page</u>
25b	Palmer Station Vertical Sounding of Ozone Partial Pressure on September 21, 1987	89
25c	Palmer Station Vertical Sounding of Ozone Partial Pressure on September 24, 1987	90
26a	TOMS Ozone Distribution for the Southern Hemisphere on September 5, 1987	91
26b	TOMS Ozone Distribution for the Southern Hemisphere on October 5, 1987	92
26c	TOMS Ozone Distribution for the Southern Hemisphere on October 17, 1987	93
27a	TOMS Ozone Distribution for the Southern Hemisphere on September 13, 1987	96
27b	ECMWF 70 mb Analysis for September 13, 1987 . .	97
28a	Orbital TOMS Ozone Contours for September 16, 1987	98
28b	ECMWF 70 mb Analysis for September 16, 1987 . .	99
29a	TOMS Ozone Distribution for the Southern Hemisphere on September 5, 1987	101
29b	ECMWF 70 mb Analysis for September 5, 1987 . .	102
30a	TOMS Ozone Distribution for the Southern Hemisphere on September 17, 1987	103
30b	ECMWF 70 mb Analysis for September 27, 1987 . .	104
30c	ECMWF 70 mb Analysis for September 27, 1987 . .	105
31a	TOMS Ozone Distribution for the Southern Hemisphere on September 28, 1987	107
31b	ECMWF 70 mb Analysis for September 28, 1987 . .	108
32a-b	TOMS Ozone Distribution for the Southern Hemisphere on October 22 and 27, 1987	109
32c-d	TOMS Ozone Distribution for the Southern Hemisphere on October 28 and 31, 1987	110

LIST OF TABLES

<u>Table</u>		<u>Page</u>
1	Selected Locations for TOMS Total Ozone Time Series	44
2	Time Series of Daily Total Ozone Values (DU)	45

1. INTRODUCTION

1.1 The 1987 Airborne Antarctic Ozone Experiment

Over the last decade, both ground-based (Farman et al., 1985) and satellite (Stolarski et al., 1986; Schoeberl and Krueger, 1986) observations have documented a startling downward trend in the total column ozone amounts over Antarctica. This decrease, which occurs seasonally during September and October, has resulted in a depletion in the column ozone amounts by as much as 50% (see Figures 1a and 1b). Except for 1986, when the ozone minimum rose slightly (Krueger et al., 1987), a steady year-by-year decrease was observed which led, understandably, to considerable concern on the part of scientists worldwide. This Antarctic ozone minimum has been termed the Antarctic "ozone hole." Several theories have been advanced to explain the loss of the ozone over Antarctica and the formation of the ozone hole. These include the effects on the total column ozone abundance due to climatic variability and changes in the stratospheric circulation patterns (Newman and Schoeberl, 1986; Chandra and McPeters, 1986), interactions with the 11-year solar sunspot cycle (Sekiguchi, 1986; Callis and Natarajan, 1986), and chemical reactions with enhanced levels of chlorine monoxide (possibly caused by the introduction of chlorofluorocarbons into the atmosphere) (Farman et al., 1985; Solomon et al., 1986). Observations from the Satellite Aerosol Measurement (SAM II) instrument (McCormick and Trepte, 1986) and the Limb Infrared Monitor of the Stratosphere (LIMS) instrument (Austin et al., 1986) on board the Nimbus-7 spacecraft have revealed the presence of Antarctic Polar Stratospheric Clouds (PSC's). These PSC's are present in the Antarctic lower stratosphere with cloud tops of from 15 to over 20 km throughout September. It has been suggested that heterogeneous reactions on the surface of the cloud particles may be related to the formation of the ozone hole (Toon et al., 1986; Solomon et al., 1986; Crutzen et al., 1986).

The theories involving man-made chlorofluorocarbons (CFC's), popular in the 1970's, were revived in an effort to explain this ominous depletion of the ozone layer. But along with this revival came alternate theories which involved the meteorological dynamics of the stratosphere. After all, if CFC's are produced in the northern hemisphere, why should their chemical effects on ozone appear so markedly in the southern hemisphere? Clearly, meteorological and dynamical mechanisms are involved.

In any case, the great concern among various scientists led to numerous expeditions to Antarctica to measure the chemical make-up of the southern stratosphere during the Antarctic spring. One of these, the National Ozone Expedition (NOZE), was led by Susan Solomon (1986) and was repeated in 1987 at McMurdo Station in Antarctica. But the NOZE team made only ground-based chemical measurements. It was clear that there was a need for an airborne sampling of the Antarctic stratosphere in spring. Thus, the 1987 Airborne Antarctic Ozone Experiment was born.

OZONE MINIMA

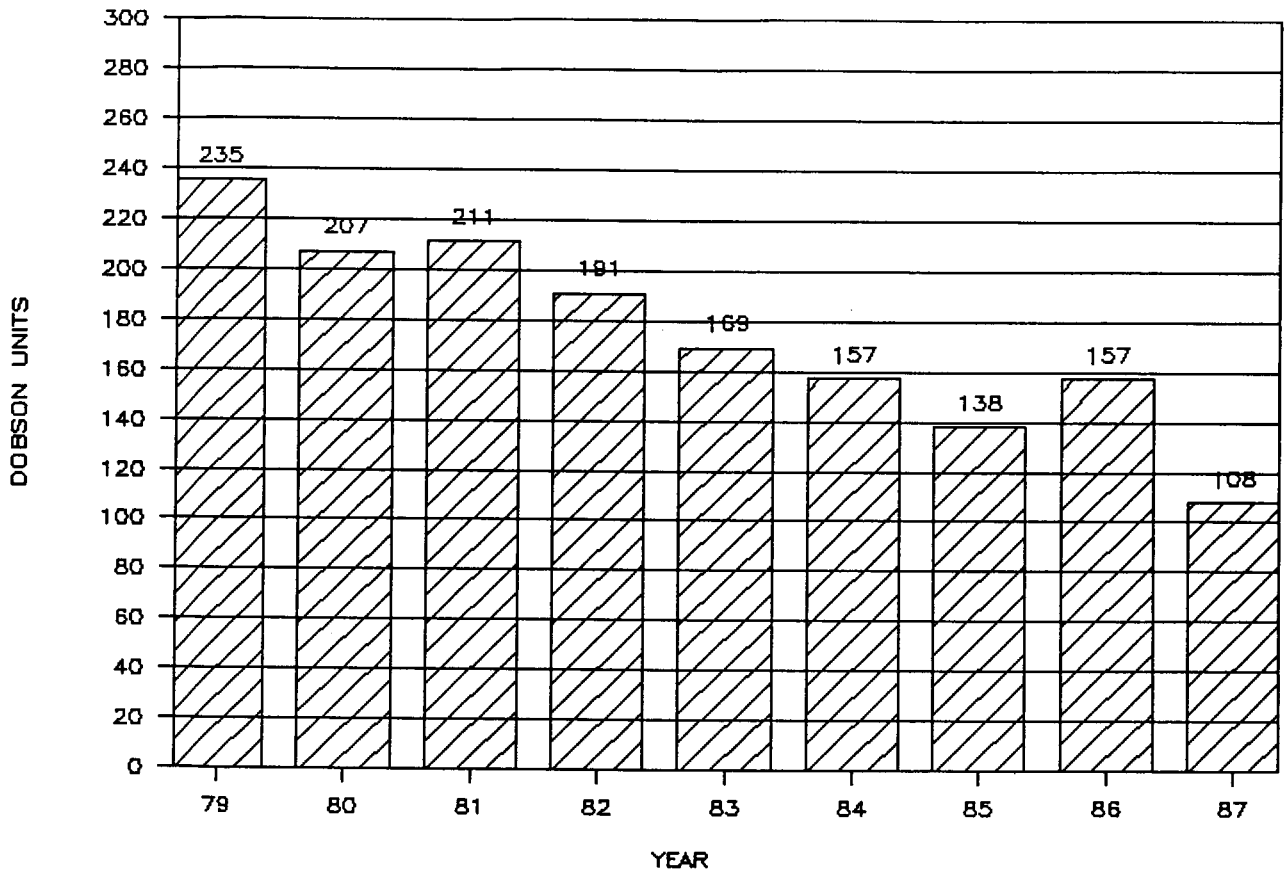

Figure 1a. A Time History of the Minimum Ozone Values Recorded by the Nimbus-7 TOMS over the Last Nine Years.

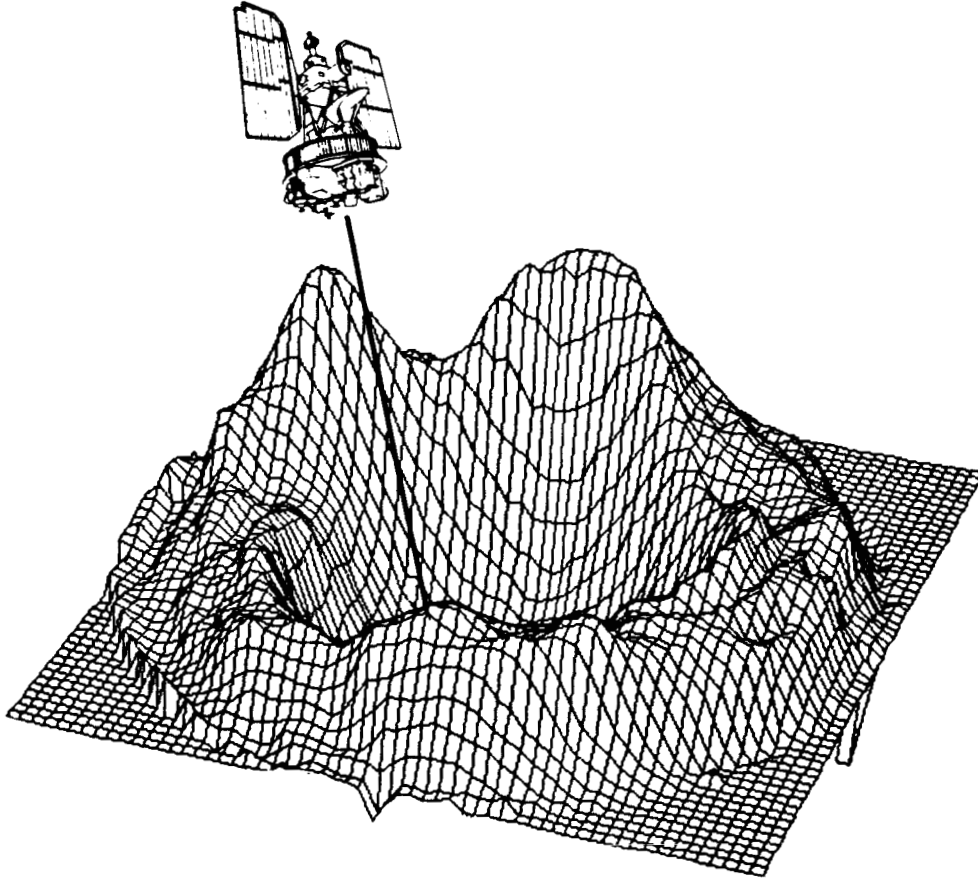

Figure 1b. A schematic representation of the Nimbus-7 spacecraft overflying the south pole. The TOMS total ozone is portrayed topographically here, with the Antarctic ozone hole clearly evident.

The goal of the 1987 Airborne Antarctic Ozone Experiment was to improve the understanding of the mechanisms involved in the formation of the Antarctic ozone hole. The 1987 Airborne Antarctic Ozone Experiment was organized and managed by NASA personnel with substantial contributions from NOAA, NSF, the Chemical Manufacturers Association, various U.S. universities, and selected European meteorological organizations. The main objective of the experiment was to monitor, with instrumented aircraft, the chemistry and meteorology of the Antarctic stratosphere during the formative stages of the ozone hole. The campaign was conducted during the period between August 8, when the mission go/no-go criteria were satisfied, and September 29, when the last Antarctic flight was conducted. This duration permitted a sampling of the preconditions to the formation of the ozone hole, as well as the opportunity to directly observe the onset and intensification of the ozone hole as it evolved during the field experiment. During the experiment, two specially instrumented NASA research aircraft were based in Punta Arenas, Chile. These aircraft flew into and below the ozone hole to make in situ and remotely sensed observations of the atmospheric chemistry and thermodynamic structure. Excluding the transfer flights to and from Punta Arenas, the ER-2 aircraft made 12 flights from Punta Arenas along the Palmer Peninsula at altitudes of from 12 to 19 km, while the DC-8 made 12 long-range flights at lower altitudes of 13 kilometers and below. Some of the DC-8 flights monitored the air from Punta Arenas to the south pole, and because of the long flight times possible with the DC-8, observations could be made all the way to New Zealand.

1.2 Requirements

In concert with NASA/Ames Research Center (ARC), a task was initiated by the Nimbus Project and the Atmospheric Chemistry and Dynamics Branch at GSFC for support by Research and Data Systems (RDS) Corporation of the 1987 Airborne Antarctic Ozone Experiment. The areas included both telecommunications and meteorological aspects. Mr. A. Oakes, of the Nimbus Project (GSFC Code 636), was designated the Contracting Officer's Technical Representative; Mr. S. Broder, Head of the Advanced Data Flow Technology Office (GSFC Code 630.4), was designated the Assistant Technical Representative (ATR) in charge of telecommunications; and Dr. R. Hudson, Head of the Atmospheric Chemistry and Dynamics Branch (GSFC Code 616), was designated the ATR in charge of Science. Dr. A. Krueger, co-Chairman of the Nimbus-7 SBUV/TOMS instruments and a Satellite Principal Investigator of the 1987 Airborne Antarctic Ozone Experiment (GSFC Code 616), was assigned to provide specific and general technical guidance. As listed in the statement of work, the following functions were to be performed by RDS, with the aid of the government scientific and communications technical representatives:

- To provide telecommunications to support the science and operations efforts for the Antarctic Ozone Hole Experi-

ment, and to supply near real-time weather information to ensure flight and crew safety.

- To design, engineer, order, lease/purchase, and install the necessary telecommunications lines and peripheral equipment needed to connect NASA Goddard Space Flight Center (GSFC), United Kingdom Meteorological Office (UKMO), Palmer Station, European Center for Medium-Range Weather Forecasts (ECMWF), and other designated participants, to the operation at Punta Arenas, Chile.
- To engineer and install Earth stations and other "stand-alone" systems as needed to collect data from designated low-orbiting polar satellites and beacons used for cloud imagery.
- To provide, in near-real-time analyses of Nimbus-7 TOMS data or backup data products to Punta Arenas
- To operate and maintain GEMPAK/GEMPLT software at GSFC and Punta Arenas
- To provide synoptic meteorological data analysis and reduction

The RDS and NASA/GSFC team was tasked with demonstrating a functioning telecommunications network by August 9, 1987. The network was a key element in the go/no-go decision for the departure of the ER-2 and DC-8 aircraft from NASA ARC at Moffitt Field, California. Prior to that departure, operators in Punta Arenas had to be capable of receiving TOMS total ozone via the GSFC VAX computer or TOVS total ozone via ECMWF facsimile from CNRM Toulouse, France. Also, mission forecasters in Punta Arenas had to have the ability to receive forecast charts from ECMWF and UKMO.

In order to carry out the myriad of assignments, planning documentation was required. As a result, RDS prepared and delivered an operating procedures manual entitled "RDS Support Project for the 1987 Ozone Hole Experiment: Plans, Schedules, and Operating Procedures Manual." This operating procedures manual provided RDS operators and NASA personnel with a comprehensive guide to the staffing, requirements, testing, schedule, and operation of the telecommunications network, including the consideration of emergencies and restoration.

The RDS/NASA team was successful in meeting the above-stated requirements and demonstrating a functioning network on schedule.

1.3 The Nimbus-7 Total Ozone Mapping Spectrometer

On October 24, 1978, the Nimbus-7 spacecraft was launched into a local-noon, sun-synchronous, near-polar orbit. The satellite has provided a measuring platform for eight different experiments and

instruments which have observed the Earth's surface, atmosphere, and oceans, and the Sun, in the ultraviolet, visible, near-infrared, infrared, and microwave regions of the spectrum. The TOMS experiment on board Nimbus-7 continues to take high quality data at this time, after more than 9 years of operation.

The TOMS has a 3° by 3° instantaneous field of view (IFOV), with a ground resolution of 50 km at the subsatellite point. The TOMS radiances are sampled in 3° steps $\pm 51^\circ$ from nadir across the ground track, yielding a total of 35 samples every 8 seconds (Heath et al., 1978). With the 104-minute orbital period of the Nimbus-7, the 8-second scan cycle means that successive scan lines are displaced a little less than 0.5°, or about 50 km, along the orbital track. Due to the Earth's rotation, each orbit of data taken by the Nimbus-7 satellite is located approximately 26° of longitude west of the preceding orbits. At the 51° extreme scan position, the field of view extends to slightly over 13° of the Earth central angle from nadir. Thus, there is no data void between orbits, even at the equator, and true global total ozone mapping is assured.

The TOMS is a single Ebert-Fastie spectrometer, and measures reflected shortwave radiation at six wavelengths ranging from 0.312 μm to 0.380 μm for each sample. The total ozone retrieval algorithm is based on a technique measuring the backscattered ultraviolet radiation (Dave and Mateer, 1967), and closely follows the Nimbus-4 BUUV total ozone algorithm (Mateer et al., 1971; Klenk et al., 1982). The measured intensities at the satellite are the sum of both the atmospheric backscattered radiation and the surface-reflected direct and diffuse contributions. The term involving the surface-reflected ultraviolet component is dependent on the atmospheric transmission, itself a function of the ozone optical depth along the slant path of the radiometer's field of view. The two longest wavelengths, which are outside the ozone absorption band and have centers at 0.360 μm and 0.380 μm , are used to determine the surface reflectance. Given the surface reflectance, the total column amount of ozone is computed from radiances observed with the four shortest wavelengths (0.313 μm , 0.318 μm , 0.331 μm , and 0.340 μm) through a table lookup and interpolation procedure (Fleig et al., 1982).

The backscattered ultraviolet radiances are inverted to yield total ozone up to a solar zenith angle of 88°. No nighttime total ozone observations are taken. Thus, the only areas of the Earth for which total ozone measurements are not recovered are at the winter poles during 24-hour night.

In support of the experiment, it was decided early on to make use of the Total Ozone Mapping Spectrometer (TOMS) aboard the Nimbus-7 polar-orbiting satellite. Near-real-time processing of these data at NASA/GSFC permitted pilots and team leaders to assess the location of the developing ozone hole and plan their flights accordingly.

The TOMS instrument played a central role in the experiment by supplying timely maps of the total ozone distribution over the southern hemisphere. These data were made available to the experiment in a near-real time mode and thus were useful in directing the aircraft by providing the location of the ozone hole boundary, and in project planning activities in general. TOMS data coverage over several orbital segments centered about the Palmer Peninsula was supplied within several hours of real time, and TOMS data coverage over the entire southern hemisphere was supplied within a day of real time.

1.4 Meteorological Analysis Support and Available Technical Resources

In support of the flight crews and missions, meteorological analyses and weather forecasts were provided by the European Centre for Medium-range Weather Forecasts (ECMWF). The United Kingdom Meteorology Office (UKMO) also provided wind and temperature data, along with isentropic charts and trajectories. The telecommunications network installed for this project by RDS was used to transfer this meteorological data between Europe, GSFC, and Chile.

Complementing the aircraft and their support facility at Punta Arenas, an operations facility was established at NASA/GSFC. The functions of this unit were to ensure prompt access to, and transmission of TOMS data to, Punta Arenas. In addition, the operations facility served as a backup for meteorological and weather forecast services. In view of these responsibilities, a wide variety of technical information was arranged for, and procured at, GSFC. Below is a list of the materials displayed in the operations room at GSFC:

1. ECMWF MAP SETS. On a daily basis, beginning about 0100 GMT, 99 charts were faxed from ECMWF to GSFC. The charts were: (a) surface pressure; (b) 850 mb wet bulb potential temperature; (c) 500 mb winds and temperatures; (d) 300 mb winds and temperatures; (e) 200 mb winds and temperatures; (f) 100 mb winds and temperatures; (g) 70 mb winds and temperatures; (h) 50 mb winds and temperatures; and (i) 30 mb winds and temperatures. The remaining charts were forecast charts out to ten days (240 hours). Only 27 of the charts were posted at GSFC. These were the initial analysis charts, along with the 24- and 48-hour forecasts.
2. TOMS IMAGERY. Each day of the experiment, two or three orbital swaths were prepared in near-real-time for transmission to Punta Arenas. These, along with the southern-hemisphere TOMS imagery from the day before, were displayed. Reflectivity analyses and northern-hemisphere imagery were also available. The GSFC Severe Storms Branch (GSFC Code 612) provided surface and

upper-air analyses for comparison with the northern-hemisphere TOMS imagery.

3. NOAA CHARTS. The National Oceanic and Atmospheric Administration (NOAA), through their Micromet network, provided digital data so that the GSFC team could prepare stratospheric charts for the 50 and 70 mb levels. Heights and temperatures at these levels were used to prepare height contours, isotherms, and charts of temperature and vorticity advection.

In addition, the NOAA personnel supplied SBUV2 data, which were also contoured at GSFC for comparison with the TOMS imagery. The SBUV2 data constituted an operational backup ozone measurement source.

4. TOVS CHARTS. Data from the Tiros Operational Vertical Sounder (TOVS) aboard the NOAA-9 and -10 polar-orbiting satellites were processed locally by Dr. J. Susskind of the GSFC General Circulation and Modeling Branch (Code 611) and in France and via ECMWF (ECMWF, 1987) by Dr. D. Cariolle. The former charts were hand carried to the operations room, while the French charts were forwarded to GSFC by ECMWF.
5. SBUV CHARTS. Dr. R. McPeters of the GSFC Atmospheric Chemistry and Dynamics Branch (Code 616) provided the Solar Backscatter Ultraviolet (SBUV) data from Nimbus-7 and, utilizing an interpolation scheme, provided the operations room with hardcopy imagery which was also used for comparison with TOMS and TOVS.
6. AEROSOL PROFILES. The aerosol profiles that were available during the experiment were derived from the Satellite Aerosol Measurement (SAM II) instrument also aboard Nimbus-7. Dr. P. McCormick of NASA/Langley transmitted these profiles to GSFC on a daily basis. These charts were useful in determining the possible presence of Polar Stratospheric Clouds (PSC's), which have often been related to the ozone minimum over the Antarctic continent.
7. PALMER OZONE AND RADIOSONDES. Dr. Torres of NASA/Wallops telemailed special sonde data to GSFC, which originated from a NASA/Wallops team temporarily assigned to Palmer station on the Antarctic peninsula. These sonde data were extremely useful in determining the levels at which the ozone depletion was occurring. They were also useful in providing ground truth for the TOMS and aircraft data.
8. INTERNATIONAL WEATHER DATA. Code 612 personnel also cooperated by providing a means of obtaining surface and upper air data through their GEMPAK interactive analysis

system. With these data, it was possible for GSFC operations to monitor weather conditions on the Antarctic continent on a near-real-time basis.

2. TELECOMMUNICATIONS NETWORK DESIGN

RDS, working with the Advanced Data Flow Technology Office at GSFC, provided a description of the telecommunications network as designed to support the 1987 Airborne Antarctic Ozone Experiment to the project office at Ames Research Center. This network design was incorporated into an experiment booklet (NASA/ARC, 1987). As requirements evolved, some minor changes to the original network design were made.

In Section 2.1 we present a detailed description of the RDS/NASA Ozone Hole Network that supported NASA's 1987 Airborne Antarctic Ozone Experiment. The network design is illustrated in Figure 2.

2.1 Overview

The network was designed to support voice communications with the Goddard Space Flight Center (GSFC) CBX 9000 to allow dial-out capability both locally and using the FTS. Additionally, the network supported facsimile operations and 9.6 kbps data transmissions utilizing DECNET software for transmission of data from the Planetary Atmospheres Computing Facility (PACF) VAX 11/780 and MicroVAX. Raw radiance data from NOAA/NESDIS were loaded onto magnetic tape and then onto the GSFC MicroVAX for transmission to the European Centre for Medium-Range Weather Forecasting (ECMWF). The network was configured with one PABX at the ECMWF and one at the United Kingdom Meteorological Office (UKMO). The communications were designed so that the personnel in Punta Arenas, Chile, could communicate with the GSFC via telephone lines that appeared to be off-premises extension (OPX) lines. The same was true for the lines that connected ECMWF and UKMO. They appeared as off-premises extensions at the PBX's, thereby presenting in Punta Arenas four lines at the airfield in the Terminal Building, Room 1 (the NASA-RDS Communications Center). There were other lines in the Communications Center which will be explained later. The CBX 9000 at the GSFC was connected to the PABX at ECMWF through a patch panel used to provide a 4-wire path for data end-to-end.

Redundancy was provided by designing the communication architecture in the form of loops. Therefore, if a connection was broken between GSFC and Punta Arenas, the information could be routed via the United Kingdom (UK). If a connection went down between GSFC and the UK, the connection could be made via Punta Arenas. A breakdown between the UK and Punta Arenas could be rerouted via the GSFC. All international lines were M1020 lines for alternative voice and data.

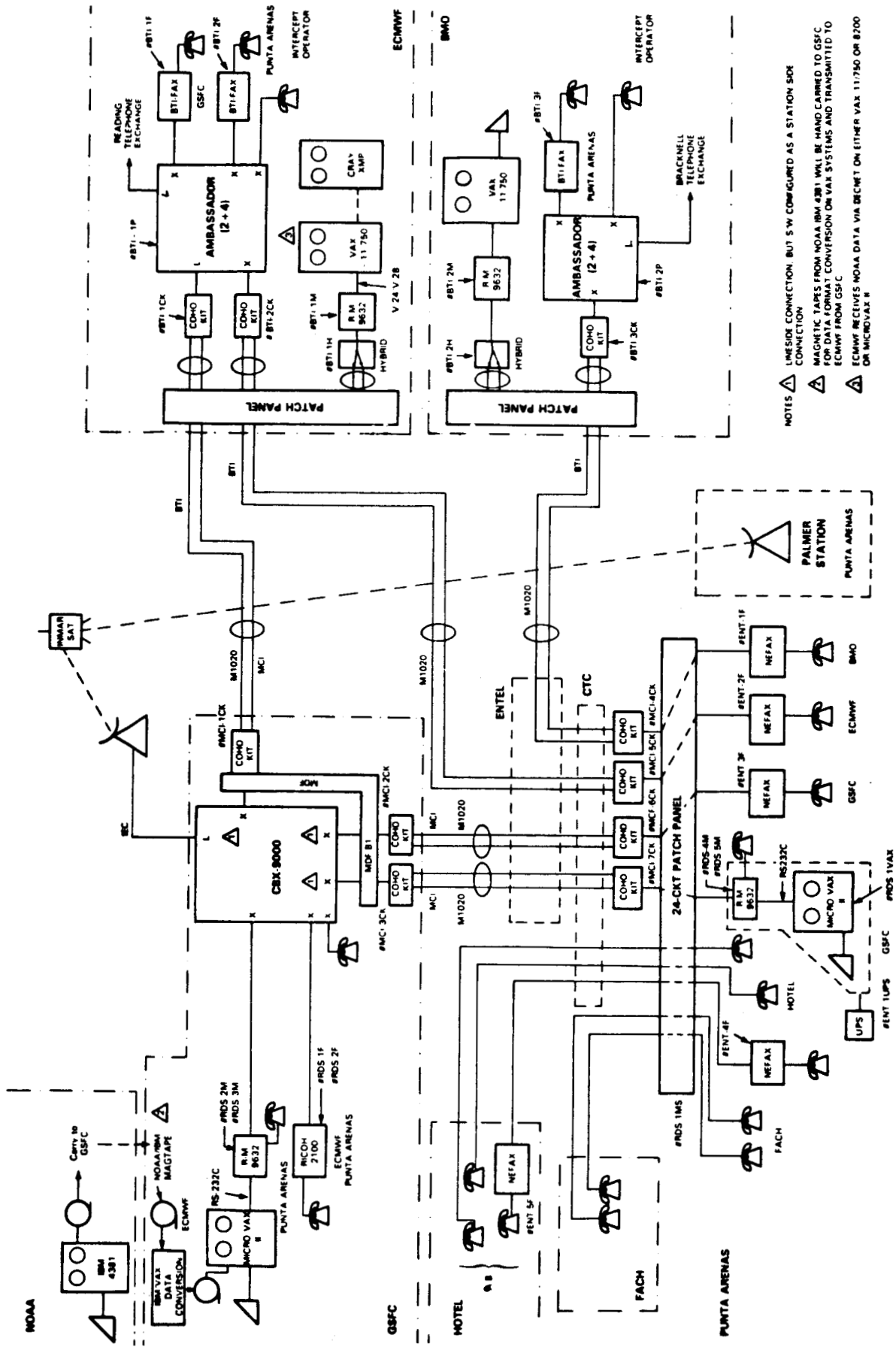

Figure 2. The design of the 1987 Airborne Antarctic Ozone Experiment telecommunications network.

2.2 ECMWF Berkshire

The ECMWF circuit to the GSFC entered the ECMWF communications facility and was connected to a patch board. The circuit between the GSFC and ECMWF was a 4-wire, M1020 circuit which extended through the patch board to a Coherent kit for signalling and exited the Coherent kit on a 2-wire circuit to enter the PABX on the line side. The PABX showed the same configuration from the extension side to Punta Arenas, thereby reacting as an off-premises extension in Punta Arenas.

On the line side, the PABX also received one access line with a number assignment to the Reading telephone exchange. The PABX had two extensions connected to facsimile machines with telephone instruments attached. There was one extension with a direct connection to a telephone instrument. This telephone was manned 24 hours per day. The operator was called when it was desired to send data between ECMWF and other locations. Upon request, the operator would patch through data to the Cray, UKMO, or other locations, thus ensuring a 4-wire connection end-to-end (except for extremely short tails). This ensured the maintenance of highest quality communication paths for data.

On the user side of the patch board, the 4-wire line passed through a hybrid to convert the 4-wire to a 2-wire connection for entry to an Racal-Milgo 9632 modem. The modem was connected via a V.24/V28 connection to the designated computer receiving the raw radiance data from the GSFC MicroVAX. This machine provided the interface to the Cray computer.

2.3 UKMO Bracknell

The UKMO brought through its entrance facilities a 4-wire connection to Punta Arenas. Both 4-wire circuits terminated on a single patch board. The line from Punta Arenas extended through the patch board to a Coherent kit. From the Coherent kit user's side, a 2-wire circuit entered the extension side of the PABX provided by British Telecommunications International (BTI). The circuit entered as an extension port. The PABX had an extension connected to a facsimile machine, supplied by BTI, with a telephone instrument. An additional extension position on the PABX directed the connection to a telephone instrument. This instrument was manned 24 hours per day. The operator performed the same functions as described under ECMWF Berkshire. On the user's side of the patch panel, the 4-wire circuit converted to 2-wire for a Racal-Milgo 9632 modem to provide for data transmission (this required a manual patch for data).

2.4 RDS-NASA Communication Center: Punta Arenas

At Punta Arenas Airport Terminal Building, Room 1, RDS established a telecommunications center. Entel-Chile brought all circuits received from the U.S. and Britain to a 24-circuit main distribution frame (MDF). Entel-Chile then terminated on that MDF two

circuits from the GSFC and two circuits from Britain, and one each from ECMWF and UKMO. Additionally, Entel-Chile provided three Central Office telephone lines to that MDF with numbers assigned from the Chilean Telephone Company (CTC) for use as Direct Dial International (DDI) telephones connected to rooms at the hotel in Punta Arenas. One of the lines was used for facsimile and voice. Entel-Chile also provided telephone instruments. Fuerza Aerea de Chile (FACH) provided two additional telephone lines from hanger #1 at the Chibunco Air Base which terminated on the MDF.

RDS provided a patch panel capability for connecting different instruments and equipment to different line positions. RDS, with the assistance of Entel-Chile, connected the patch panel with the line side connected to the four M1020 circuits. On the line side, RDS, with Entel-Chile's assistance, connected the Coherent kits, provided by RDS, to three Nefax facsimile machines (to GSFC, UKMO, and ECMWF) with telephone instruments and a Racal Milgo 9632 modem (to GSFC) connected to a MicroVAX-II computer. Additionally, a Nefax with a phone instrument was connected directly to the MDF for connection to a Central Office DDI line. From the MDF, two telephone instruments were connected to two additional access lines to the Central Office (DDI). Further, the two lines from Hangar 1 were equipped with instruments and signalling necessary to communicate with personnel in Hangar 1. These instruments were connected so that when the handset was off-hook, the corresponding phone at the other location immediately began to ring.

2.5 RDS-NASA Communication Center: Cape Horn Hotel in Punta Arenas

Entel-Chile issued orders to the CTC to install three telephone lines with direct connection between the Central Office and rooms designated by the hotel manager. The hotel PBX was bypassed. These lines were DDI lines. One line supported a Nefax and handset attached and the others supported phone instruments only.

2.6 Goddard Space Flight Center (GSFC)

GSFC had a Rolm CBX 9000 switch, with the main entrance facilities in Building 1 where a MDF resided. All circuits connected internationally entered the GSFC for connection at the main entrance facilities and resided on the MDF. GSFC's Rolm switch personnel ordered lines to be connected from the MDF to the CBX 9000. These lines were connected on the line side of the switch, but were configured to appear as off-premises extensions. GSFC provided the necessary analog circuit facilities. GSFC accepted circuits from the UK and Punta Arenas after processing through Coherent kits on-station. GSFC provided analog facilities to the MicroVAX in Building 21, Room C-222 which connected to an RDS-provided Racal-Milgo 9632 modem. GSFC also provided analog facilities from the switch to Building 21, Room C-222 for connection to a Ricoh 2100 facsimile. GSFC provided analog telephone instruments to be used on both circuits in Building 21. Data from NOAA were carried by tape and loaded onto a MicroVAX at Building

21 of GSFC. The MicroVAX was equipped with DECNET software to communicate with designated computers at ECMWF and Punta Arenas. The capability existed for dialing the appropriate off-premises extension number of ECMWF directly and telling the ECMWF operator that data were ready to be transmitted. ECMWF then made the necessary patch to remove that line from the PABX and place it on line with the Racal-Milgo 9632 modem used for data (as previously discussed).

In addition to the four international lines, an INMARSAT circuit was provided to interconnect Palmer Station with the Operations Center in Punta Arenas. This was a voice-only circuit. The International Gateway in Connecticut was accessed via the CBX 9000 on FTS. All calls were dialed up and charged by the minute.

2.7 Operation of the System

With the above-stated configuration, a person in the U.S. who required communication with the RDS-NASA Communications Center in Punta Arenas simply dialed the 7-digit number on the CBX 9000 at GSFC and immediately contacted the number in Punta Arenas, either for the Nefax/telephone instrument or the telephone instrument associated with the MicroVAX. If the line was in use, a busy signal was received as with any other call.

A project member with authorization from the appropriate person in charge in Punta Arenas picked up the telephone instrument and dialed either a local number or the appropriate FTS number for the U.S. correspondent required. If the fax was required, upon hearing the fax tone, a person would start the machine.

A person in the U.S. requiring data transmission, dialed the 7-digit number that rang the instrument associated with the Racal-Milgo 9632 modem in the computer room in Punta Arenas and commenced communication. In Britain, a person requiring voice communication with Punta Arenas would call either of two numbers, one assigned to the ECMWF PABX from the Reading telephone exchange or the PABX at UKMO with direct connection to the Bracknell telephone exchange. At either of these two sites, the PABX provided direct connection to Punta Arenas.

A project person in Punta Arenas who required communication with Britain simply picked up either telephone that was available, dialed 9, and received the dial tone from either Reading or Bracknell telephone exchanges and proceeded to dial the number.

A person in Punta Arenas requiring communication to the U.S. during a communication outage between Punta Arenas and the U.S. picked up the telephone to the ECMWF, dialed the extension of the line connected to the GSFC, and received a dial tone directly from the GSFC. By the same token, if an outage occurred between the UK and Chile, the person in Punta Arenas at the RDS-NASA Communications Center picked up the telephone and received a dial tone from the GSFC. They then dialed the appropriate on-base extension

number of ECMWF. If it was desired to transmit data, the operator made the connection via the patch panel. If it was desired to access any other extension, they accessed it directly.

3. INSTALLATION OF THE TELECOMMUNICATIONS NETWORK

3.1 Schedule

The go/no-go decision date for aircraft deployment from NASA/Ames Research Center was not flexible and, therefore, forced a rigid schedule. That decision required a functioning network on August 9, 1987. In order to meet the deadline, a schedule was proposed. This schedule is illustrated in Figure 3.

There were several items on the schedule which were critical and had the potential to jeopardize meeting the deadline. Some of the more significant of these were ordering the telecommunications lines and equipment, timely shipping and arrival of equipment, and equipment installation and testing.

3.2 Ordering the Telecommunication Lines and Equipment

The lead time associated with ordering telecommunications lines and certain equipment (i.e., signalling devices) is long. RDS was successful in ordering the equipment such that installation did not adversely affect the establishment of the network; however, significant problems existed. These are addressed in more detail in Section 8.

For the most part, major pieces of equipment were available on-site. Those that were not were shipped by air freight. Much of the needed equipment was acquired quickly and without additional costs associated with expediting the orders. Most of the equipment was available through multiple vendors. Where equipment was identified as in-stock and reasonably priced, it was acquired without difficulty.

3.3 Timely Shipping

The shipping of equipment proved to be difficult and the potential for failing to meet the deadline existed in this aspect of the project. In some cases, equipment had to be tested and configured before it was sent to Punta Arenas. For example, it was necessary that the MicroVAX computer to be used in Punta Arenas be able to communicate with the VAX computer at GSFC. The MicroVAX could not be shipped to Punta Arenas until that capability existed. If problems were identified, they had to be worked out in advance, because the expertise to solve them would not necessarily exist in Punta Arenas. Additionally, there was no backup modem for the MicroVAX in Punta Arenas. Therefore, the modem had to be tested and configured with the GSFC modems and, in turn, the ECMWF modems, to be sure that they would operate with the modem in Punta Arenas. Obviously, it would have been preferable to have had the equipment sooner. Fortunately, the necessary adjustments were

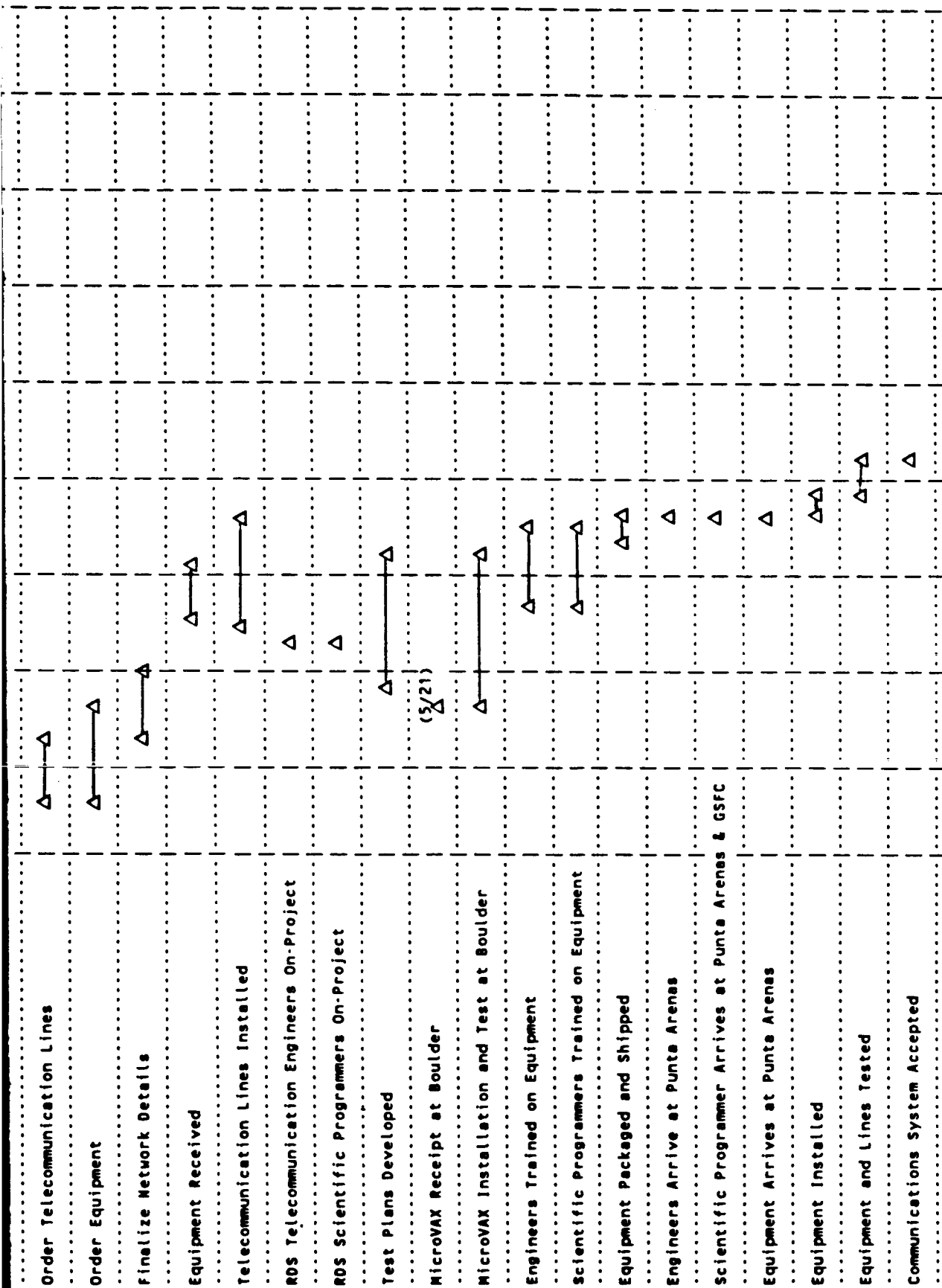

Figure 3. Milestone chart for the performance of the various aspects of support of the 1987 Airborne Antarctic Ozone Experiment.

OZONE HOLE EXPERIMENT SCHEDULE	4/87	5/87	6/87	7/87	8/87	9/87	10/87	11/87	12/87
Decision on Network Termination					Δ				
Operations					Δ	Δ			
Equipment Packaged and Shipped (GSFC)							Δ	Δ	
Telecommunications Engineers Return to U.S.							Δ		
Telecommunications Final Report						Δ	Δ		
Meteorological Final Report					Δ				

Figure 3 (continued). Milestone chart for the performance of the various aspects of support of the 1987 Airborne Antarctic Ozone Experiment.

made in time. The next priority was ensuring that a reliable means existed to get the equipment to Punta Arenas on time. RDS understood the absolute necessity that the equipment be forwarded expeditiously, and with minimal or no damage. A plan for movement of the equipment to Punta Arenas was provided in Chapter 7 of the operating procedures manual (see Section 1.3). In that plan, RDS intended for a freight forwarder to ensure the equipment was shipped to Punta Arenas. However, provisions were made for a member of the RDS telecommunications team to meet NASA officials in Santiago, and together NASA and RDS would assist in clearing the equipment through Chilean customs. This was an extra measure to ensure the equipment's continued progress. A freight forwarder was contracted based on assurances that the equipment could arrive in Punta Arenas on the date we selected to begin installation. The equipment was delivered for shipping, but problems occurred. Previously the freight forwarder stated that he would forward the cargo via a cargo carrier and not a passenger flight to ensure it's continued progress. This he failed to do, resulting in the equipment off-loading in Miami, Florida to make room for baggage and mail. As a result of a misunderstanding, the freight forwarder thought his responsibility extended only to Santiago. Therefore, he did not arrange for continued movement of the cargo to Punta Arenas. The result was that RDS and NASA personnel in Santiago arranged for the movement of equipment from Santiago to Punta Arenas. The equipment arrived undamaged, five days later than scheduled.

3.4 Equipment Installation

Once the equipment arrived, installation was possible. Prior to the team's arrival in Punta Arenas, Entel Chile had begun assembling the main distribution frame for the signalling kits, and had made arrangements for installation of the telephone lines. When the equipment arrived in Santiago, the signalling kits were separated from the rest of the equipment so as to begin testing. This process took approximately one day. Once the testing was completed, the kits were forwarded to Punta Arenas. Entel Chile installed the leased equipment. Once installed, the telephone lines were connected to the patch panel. Installation proceeded well, but there was some pressure to make up for lost time. Again, in spite of the difficulties, the network was installed quickly and was soon made ready for operation.

3.5 Network Testing

A test plan was developed in Chapter 10 of the operating procedures manual (Section 1.3) to itemize necessary tests and provide a systematic method for accomplishing each test. The test plan was developed to provide for the efficient use of the limited time available for the establishment of the network. It was anticipated that, if problems developed, a systematic approach would help to diagnose and rectify the problems quickly.

The test plan provided for testing in two phases. The first phase consisted of testing equipment individually outside of, and within, the network. In this way, RDS operators could be sure that the individual pieces of equipment were operating within specifications. The second phase consisted of testing the interaction of various pieces of equipment once installed within the network.

Testing the various components of the network began as soon as the equipment arrived. For example, the Racal-Milgo 9632 modems were tested and configured. Because the same modems would be used at GSFC and Punta Arenas, it was relatively easy to operate the pair. A challenge was to get the British Merlin modems to operate with the Racal-Milgo modems. Ultimately, additional Racal-Milgo modems had to be leased and sent to UKMO and ECMWF. This occurred as late as July 24, 1987, leaving little time for the testing of network functions.

In some cases, testing was not possible prior to departure. The signalling units for Punta Arenas were such an example. They arrived just in time to ship with the cargo, but not in time to test prior to departure. Therefore, it was required that representatives of Entel Chile intercept these devices in Santiago, complete the testing, and then hand-carry them to Punta Arenas.

Although a systematic plan existed for testing, it was not possible to complete the testing according to plan. Literally, various components were tested and checked-off just after installation. The looming go/no-go deadline was the reason for the urgency. The ripple-effect caused by the late receipt of equipment receiving equipment late, etc., did not affect the deadline date. Therefore, as events slipped a day or so, it left less and less time for testing. Ultimately, the testing and installation was completed, and the network was accepted on time.

4. NETWORK OPERATIONS

Operation of the communication center began once the installation and testing of the network were completed. A comprehensive operating plan was provided for in the operating procedures manual (see Section 1.3). The purpose was to detail various procedures to be used in the operation of the network. The plan addressed communication priorities and information transfer priorities. In practice, communications uses rarely conflicted. Generally there was more than one way to accomplish ones needs, or project participants were patient enough to wait until their needs could be fulfilled.

Of some importance was the plan to rectify problems as they occurred. It was critical that no portion of the project adversely impact the success or safety of the experiment. Theoretically, telecommunications presented the greatest potential for negative impact. As such RDS planned for expediting repairs to minimize network impact. The plan provided for escalation of

problem notification until a problem was solved. In practice, the escalation plan worked well. Equipment vendors were receptive to our need to quickly return to a fully functioning network, and were able to resolve problems at the lowest level.

Chapter 8 of the operating procedures manual (see Section 1.3), was devoted to network restoration. The purpose of the plan was to provide users of the network a guide to restore network communications after some form of failure, to standardize procedures for restoration, and provide appropriate notification. Because of the redundant nature of the network, it was possible to re-route communications via an alternate means until normal network operations resumed. However, a change in communications paths affected priorities, information exchange, communications availability, scheduling, etc. The restoration plan defined the various levels of failure and action to be taken at each level, until normal operations resumed.

4.1 Communications Watch

On August 5, RDS began continuous manning of the communications center. The on-site telecommunications team consisted of four people. The four rotated on three daily eight-hour watches beginning at 12:30 AM, 8:30 AM, and 4:30 PM. As an operator was needed in the communication center at all times, it was typical to have another operator resolving problems at the hangar or at the hotel communications center. The rotating watch system proved to be effective. In the event that a team member became ill, three people were able to continue to man the center without affecting the operations.

While on duty, operators in the communication center were responsible for relaying telephone calls via the patch panel, operating the facsimile machines, keeping appropriate logs, and initiating responses to degraded telecommunications services. Each area of operation is addressed separately in the following paragraphs.

4.2 Patch Panel

The patch panel proved invaluable and permitted numerous advantages. The panel offered convenience, in that personnel did not have to leave their work area or hotel to place calls on the network. For example, personnel at their hotel in Punta Arenas could dial the communication center on a Dedicated Direct International (DDI) line and ask for connection to the hangar on the FACH (on-base) line. Because it was convenient, it eliminated the need for people to conduct business in the telecommunications center. This, in turn, reduced the distraction to the nearby meteorological office and computer room.

The panel also provided flexibility to quick restoration of service. In one instance, the UKMO facsimile went out of service at a time when forecast charts were being provided. The patch panel permitted instant re-routing of the UKMO telephone line

(Britain 13) into a less-committed facsimile machine (connected to the DDI line), thereby restoring service. Once the machine was repaired, it was placed on-line without affecting the flow of UKMO charts.

4.3 Facsimile

There were four facsimile machines in the communications center. Three were dedicated to international leased lines, and the fourth was connected to a local Chilean Telephone Company (CTC) DDI line.

All facsimile machines were connected to the patch panel, and, as such, they could be interchanged as previously mentioned.

In the communications center, two machines (UKMO and ECMWF) operated in a similar manner. Both received more data than they transmitted, operated on a schedule basis, and were constantly used. In the United Kingdom, the two machines were physically located about twelve miles apart. Therefore, if one machine was unreachable over the DDI, it was possible to use the other line to access the local public switch network in the UK, and place a local telephone call to that machine. For that reason, telephone numbers were preset to each machine. Under normal operations, the first speed-dial button was set for the two-digit number to access the distant machine in the UK. To send a facsimile, the operator loaded the document in the machine, pressed the preset number, and the document was transmitted.

Another speed-dial button was preset to the local telephone number of the distant machine. In this way, it was possible to make a facsimile transmission if the distant machine was operating, but the international line was not. To send a facsimile chart, one could make a temporary patch of the facsimile machine to the other UK line, press the local telephone number speed dial button, and the machine would transmit.

The described situation did occur at 23:30 (EST) on August 21, 1987. There was no dial tone on Britain 14 connecting the UKMO facsimile to a Punta Arenas facsimile. The UKMO operator contacted an ECMWF operator asking to relay a message to the communications center in Punta Arenas stating that they were having problems. The RDS operator connected the UKMO facsimile to the ECMWF line, pushed the local UKMO number speed dial button, sending the UKMO operator instructions to initiate line restoration procedures. Although the RDS operator was able to patch around the problem, unfortunately the UKMO operator could not. In this situation, it would have been better for the UKMO operator to have had that option as well, so as to avoid impeding the flow of charts to Chile.

All incoming and outgoing facsimile charts were logged. The log enabled operators to keep track of information received and action taken on those items requiring it. It also provided a quick reference for the arrival or status of scheduled charts. On a

typical day, approximately 250 charts were received or transmitted on each of the UKMO and ECMWF machines. A sample page of the log is provided in Figure 4. In addition, each machine was set to produce an activity report. This report was printed every 35 transmissions or receptions. It provided a quick glance at the frequency of transmission or reception failures, indicating a need for investigation into potential problems. A sample report is provided in Figure 5.

The facsimile on the United States line was operated differently. It was not used as often, did not receive as many charts at any one time as the UK machines, and was not receiving charts on a scheduled basis. When the SAM II data were received, the transmission normally took a considerable amount of time; however, SAM II data were received only at a frequency of once per day. (Each UK machine generated six times the volume of the GSFC machines.) Therefore, the line lent itself to use as an alternate voice line. For that reason, that machine was not set to answer the phone automatically (unlike the UK machines). When scientists needed to contact their home bases, they were able to do so on that line.

The local facsimile machine connected to the DDI line was used to transmit information between the Cabo de Hornos Hotel and the communications center. These two machines were connected by dialing the local numbers. Another machine, located in the hangar, was connected to the FACH line. Personnel wishing to transmit information from the hotel to the hangar were required to contact the base operator (Spanish-speaking) and then transfer the call to the hangar. From the communications center, a patch was made from the FACH telephone into the DDI machine to contact the hangar. The DDI facsimile (FAX) machines in the hotel and communications center were set for automatic reception. Each location had two additional DDI lines for voice. To send a fax from the hangar was much easier. The operator dialed nine to access an off-base line and then dialed the desired DDI facsimile number.

It was possible to send information via a relay system, but this system was not suitable for all purposes. If an individual needed to send a message from the hangar to Ames Research Center, he could send a fax to the communications center with instructions to forward the message. When received, the RDS operator would retransmit the data over the GSFC facsimile. The quality of transmission received at Ames would be fair. However, this system was expedient and used with great success. It was not suitable when the quality needed at the receiving end was high.

4.4 Trouble Ticket

Trouble tickets were used to document problems and identify notification. A sample trouble ticket is provided in Figure 6. It was obvious in advance that problems were going to occur from time to time. The trouble ticket was a tool to deal with the problems. In the event a problem surfaced requiring a vendor to

DATE	FROM	TO	DESCRIPTION	NO. PAGES	COMMENTS	TIME	INT
9/6	ECMWF	P. SALTER	FORECAST CHARTS	9	# 9-17	1722	UK
9/6	ECMWF	P. SALTER	FORECAST CHARTS	1	18	1727	UK
9/6	ECMWF	P. SALTER	FORECAST CHARTS	10	19-27	1739	UK
9/6	ECMWF	P. SALTER	FORECAST CHARTS	10	28-36	1756	UK
9/6	ECMWF	P. SALTER	FORECAST CHARTS	10	37-45	1813	UK
9/6	UKMO	P. SALTER	FORECAST CHARTS	23	300 SERIES	1819	UK
9/6	UKMO	P. SALTER	FORECAST CHARTS	23	400 SERIES	1829	UK
9/6	ECMWF	P. SALTER	FORECAST CHARTS	10	46-54	1832	UK
9/6	ECMWF	P. SALTER	FORECAST CHARTS	10	55-63	1846	UK
9/6	UKMO	P. SALTER	FORECAST CHARTS	8	501-508	1848	UK
9/6	UKMO	P. SALTER	FORECAST CHARTS	10	500 SERIES	1857	UK
9/6	UKMO	P. SALTER	FORECAST CHARTS	17	600 SERIES	1905	UK
9/6	UKMO	P. SALTER	DATA	1		1844	UK
9/6	ECMWF	P. SALTER	FORECAST CHARTS	10	64-72	1859	UK
9/6	ECMWF	P. SALTER	FORECAST CHARTS	11	73-81	1900	UK
9/6	ECMWF	P. SALTER	FORECAST CHARTS	10	82-90	1900	UK
9/6	ECMWF	P. SALTER	FORECAST CHARTS	10	91-99	1957	UK
9/6	UKMO	P. SALTER	MET DATA	1		2034	UK
9/6	UKMO	P. SALTER	MET DATA	1		2142	UK
9/6	UKMO	P. SALTER	MET DATA	1		2233	UK
9/6	ECMWF	A. TUCK	OZONE TONS	2		2055	UK
9/7	UKMO	P. SALTER	MET DATA	1		0023	UK
9/7	UKMO	P. SALTER	FORECAST CHARTS	17	100 SERIES	0025	UK
9/7	UKMO	P. SALTER	CHARTS 200 SERIES	24		01:10	NA
9/7	UKMO	P. SALTER	MET DATA	1		1:37	NA
9/7	UKMO	P. SALTER	CHARTS 300 SERIES	23		1:50	NA
9/7	UKMO	P. SALTER	CHARTS 400 SERIES	23		2:26	NA
9/7	UKMO	P. SALTER	MET DATA	1		2:21	NA
9/7	UKMO	P. SALTER	CHARTS 500 & 600	34		2:50	NA
9/7	ECMWF	P. SALTER	OZONE /CUM	1		2:51	NA
9/7	UKMO	P. SALTER	MET DATA	1		3:10	NA
9/7	ECMWF	P. SALTER	OZONE /CUM	1		6:01	NA

Figure 4. A sample page (page 37) of the facsimile log, illustrating the volume of traffic over a portion of September 6 and 7 during the experiment.

ORIGINAL PAGE IS
 OF POOR QUALITY

ACTIVITY REPORT [RECEPTION]

9.19.1987 20:17

RDS-NASA PA CH UK 20

NO.	DATE	TIME	DURATION	REMOTE ID	MODE	PAGES	RESULT
1	9.19	2133	39"	0344 400117 22	G3	1	O.K.
2	9.19	2134	40"	0344 400117 22	G3	1	O.K.
3	9.19	3143	40"	0344 400117 22	G3	1	O.K.
4	9.19	4136	37"	0344 400117 22	G3	1	O.K.
5	9.19	5137	34"	0344 400117 22	G3	1	O.K.
6	9.19	6139	34"	0344 400117 22	G3	1	O.K.
7	9.19	0134	32"	0344 400117 22	G3	1	O.K.
8	9.19	0136	41"	0344 400117 22	G3	1	O.K.
9	9.19	0142	45"	0344 400117 22	G3	1	O.K.
10	9.19	10110	23"	0344 400117 22	G3	0	N.G. 45
11	9.19	10119	49'04"	0344 400117 22	G3	59	O.K.
12	9.19	11139	39"		G3	0	NO ANSWER
13	9.19	11143	10'03"	0344 400117 22	G3	26	O.K.
14	9.19	12122	11'19"	0344 400117 22	G3	10	O.K.
15	9.19	12134	52"	0344 400117 22	G3	1	O.K.
16	9.19	12140	14'00"	0344 400117 22	G3	24	O.K.
17	9.19	13125	13'44"	0344 400117 22	G3	23	O.K.
18	9.19	13139	36"	0344 400117 22	G3	1	O.K.
19	9.19	13150	17'12"	0344 400117 22	G3	23	O.K.
20	9.19	14109	13'46"	0344 400117 22	G3	20	O.K.
21	9.19	14127	10'02"	0344 400117 22	G3	17	O.K.
22	9.19	14139	9'57"	0344 400117 22	G3	17	O.K.
23	9.19	14150	30"	0344 400117 22	G3	1	O.K.
24	9.19	14152	41"	0344 400117 22	G3	1	O.K.
25	9.19	15113	1'00"	0344 400117 22	G3	2	O.K.
26	9.19	15116	20'11"	0344 400117 22	G3	30	O.K.
27	9.19	15130	39"		G3	0	NO ANSWER
28	9.19	15142	1'40"	0344 400117 22	G3	2	O.K.
29	9.19	15146	1'21"	0344 400117 22	G3	2	O.K.
30	9.19	16114	5'01"	0344 400117 22	G3	10	O.K.
31	9.19	16121	39"		G3	0	NO ANSWER
32	9.19	16125	15'45"	0344 400117 22	G3	21	O.K.
33	9.19	16142	6'42"	0344 400117 22	G3	12	O.K.
34	9.19	16159	43"	0344 400117 22	G3	1	O.K.
35	9.19	20117	37"	0344 400117 22	G3	1	O.K.
TOTAL			3'41'04"			321	

Figure 5. A sample facsimile reception report summarizing 35 transmissions, which included 321 pages of data, during 18 hours of September 19.

RDS TROUBLE TICKET

OUTAGE/PROBLEM HIGH NOISE, GROUND Loop, NO TONE
SIGNAL, ACCIDENTALLY DISCONNECTED MCI'S CABLE BY
ELECTRICAL MAINTENANCE PERSON. KNOCK OUT A ROW OF
RDS CIRCUIT # AMERICAS 11 & 12 GAUGES.
MCI CIRCUIT # WT 261 & WT 262
BTI CIRCUIT # _____
ENTEL CIRCUIT # _____
C&P CIRCUIT # _____
ATT CIRCUIT # _____
GSFC CIRCUIT # _____
EQUIPMENT VENDOR MCI

NOTIFICATION

PERSON	TIME	PERSON NOTIFIED	FOLLOW-UP TIME	FOLLOW-UP TIME	SIGNATURE OF REPORTER
PROJECT MANAGER	9/17/87 1330				
PRINCIPAL INVESTIGATOR					
ON-SITE MANAGER	1330				
WOODY WHEAT					
COMMUNICATION CARRIER		MCI MICK PERRY	1500	9/12/87 1530	A. J. [Signature]
DC-8 CHIEF					
ER-2 CHIEF					

Figure 6. A sample trouble ticket illustrating the notification and follow-up processing accompanying a noise-level problem.

take some action, a trouble ticket was initiated. At that time, the RDS operator would begin initial notification of appropriate people to solve the problem or restore service. If a problem could not be solved at that initial level in a given time frame, then the next higher level was notified, and so on, until the problem was corrected.

In the example shown in Figure 6, high noise level was found on the two circuits from Chile to the United States on September 19. The on-site manager notified the project manager and communications carrier at 13:30 (local). At 15:00, he followed up with a call to the communications carrier. At 15:30 the problem was solved. (In this case, a maintenance worker at MCI had accidentally disconnected a cable.)

In application, the trouble ticket format was not as useful as we anticipated. Although the documentation of the notification time is important, it is not nearly as important as documenting the cause of the problem and its ultimate solution. A better method would be to change the format to permit emphasis on detailing the problem and the solution to that problem. In this way, the ticket would also provide a history of various problems on the line.

4.5 Hotel Communication Center

A communications center was established in the Cabo de Hornos Hotel. It was operated by two Chilean Spanish/English-speaking interpreters. They worked two eight-hour shifts each day, starting at 6:00 AM and 2:00 PM. The hotel communication center was closed from 10:00 PM to 6:00 AM. They operated three DDI telephones, one of which was connected to a facsimile machine. To control long-distance telephone calls, they were provided with an access list and logged all calls. Other callers were required to provide prior approval from project management.

This system seemed to work well. The NASA personnel working at the hotel had the communications access that they required. Additionally, personnel living at that hotel and the nearby Los Navagantes Hotel had access to interpreters for telephone conversations with non-English-speaking Chileans.

4.6 Problems

The operation of the communications center was smooth. Once a routine was established and the locations for delivery of scheduled charts identified, the operations went well. As project personnel arrived, they were indoctrinated in the capabilities of the communication system.

Obviously, not all events can be foreseen and planned for. One such event occurred in Punta Arenas from September 2 through 11. The position of the Sun and the communications satellite location aligned to effectively block the possibility of incoming or outgoing transmissions. The Punta Arenas satellite was affected

for 15 minutes from approximately 13:15 to 13:30 GMT from September 2 through 6. The Santiago satellite was affected at the same time from September 7 through 11. The operators at RDS were notified of the sun/satellite condition. The on-site manager provided notification to the other stations on the network via facsimile. A copy of that transmission is provided in Figure 7. As no charts were scheduled during those times, the impact on the network was minimal. However, the potential for problems existed. The possibility that Chile did not have additional satellite coverage to avoid the condition was overlooked. It is a condition worth investigating in the future.

4.7 Termination

The communications center officially closed on October 1, 1987. The ER-2 and DC-8 aircraft had departed Punta Arenas on October 1 and September 29, respectively. There was no further need for weather forecast charts. In fact, the computer room in Punta Arenas closed on the evening of September 26, 1987, because that equipment required staging on the 27th for loading on the USAF C-141 aircraft on the 28th.

There was nothing unusual about the termination of the network. Those persons that required communication were able to conduct business prior to the closing. In fact, very few people (mostly logistics personnel) remained. Once the decision was made to terminate, the equipment was disassembled and packed.

The hotel communications center was closed on the evening of September 30. Again, most experimenters had departed Chile on the DC-8, and communication was not required. The equipment owned by Entel Chile was picked up at the hotel and airport communication centers on October 2.

The 24-hour operations ceased on September 29. RDS operators began departing on the 30th; however, operators remained to maintain a 6:00 AM to 10:00 PM watch for telephone and facsimile messages. The last team member departed on October 3.

5. TOMS DATA PREPARATION AND TRANSFER

The near-real-time processing and transfer of TOMS ozone data commenced on August 8, 1987 and concluded on September 29, 1987. The processing involved two data sets: (1) complete southern hemispheric data for the 24 hours ending at midnight of the day prior to transmission and (2) orbital swath data for the region including and adjacent to Punta Arenas, Chile, and the Palmer Peninsula of Antarctica processed the same day it was observed.

5.1 Data Available to Punta Arenas

The orbital swath data consisted of 2 to 3 orbits daily, which were processed and transferred to Punta Arenas as they were received. Selection of the particular orbits was effected well in

VERY IMPORTANT NOTICE

ORIGINAL PAGE IS
OF POOR QUALITY

TO : GSFC/UKMU/ECMWF
FROM : RDS/NASA Com Center (P.A.)
DATE : 9 3 77



SUBJECT: Telephone lines To Punta Arenas

Due to the position of Sun and the Satellite location,
The telephone communication to and from Punta Arenas
is disconnected for a few minutes every day for about
ten days. This problem occurs twice a year (every six months).
The following time table provides the approximate time of the day
which lines are down: Please plan your transmissions and calls
in such a manner to avoid any problems.

September	GMT	
2	13:18 - 13:30	} Punta Arenas Satellite is affected
3	13:30 - 13:38	
4	?	
5	?	
6	?	
7	13:24 - 13:28	} Santiago Satellite; is affected
8	13:23 - 13:29	
9	13:22 - 13:30	
10	13:21 - 13:29	
11	13:22 - 13:28	

Figure 7. Timely notification of an unforeseen communications problem.

advance through the use of predictive ephemeris to generate tables of the orbital ascending-node times and longitudes and plots of the orbital subsatellite tracks (Figure 8). The real-time data flow and transfer is illustrated in Figure 9. Telemetry from the Nimbus-7 spacecraft was downlinked to one of NASA's network of spaceflight tracking stations, such as that at Wallops Island, Goldstone, or Santiago, and then transmitted over the NASA Deep-Space Network to the Goddard Space Flight Center (GSFC). The raw TOMS data from each orbit were received at the Mission Operations Control Center (MOCC) in Building 3 at the GSFC and placed onto magnetic tape. This tape was then manually transferred to the NASA Space and Earth Sciences Computing Center (NSESOC) in Building 1 at the GSFC where the raw data were processed into total ozone and reflectivity data on an IBM 3081 computer. These data were tagged with a date and time of observation plus a latitude and longitude location and placed on an IBM 3081 disk file.

This disk file was copied to the dedicated TOMS MicroVAX II computer in Building 21 at the GSFC via a fiber optics Ethernet connection. At this point, the orbital swath data were processed prior to release to Punta Arenas. This processing included the gridding of the calibrated ozone-T data to create an image file, with further processing to display the image file. The data files, one for each of up to three orbital swaths, were then transferred via DECnet and two Racal-Milgo 9632 forward error-checking modems at 9.6 kilobits/second (kbps) to a second MicroVAX II located in Punta Arenas. The orbital-swath processing required approximately 30 minutes. The total elapsed time between the actual Nimbus-7 pass over the orbital area and the receipt of total ozone data in Punta Arenas varied between 3 and 4 hours. Once received at Punta Arenas (and at GSFC as well), the data were plotted both in contour form using GEMPAK, as shown here, and in color using a Tektronix 4692 plotter and a standardized color look-up table. The color plots facilitated comparison and permitted rapid interpretation of day-to-day changes in the ozone pattern.

The hemispheric data were processed in a similar fashion, but the elapsed time was greater. A full duration of 24 hours is required for the Nimbus-7 TOMS to obtain global (or southern hemispheric) coverage. The hemispheric data set, containing total ozone data from a complete day of Nimbus-7 orbits, was available to the TOMS MicroVAX by approximately noon of the following day, or 12 hours after Nimbus-7 completed its last orbit of the day. This data set was gridded on the IBM 3081 and required minimal further processing prior to transfer. The hemispheric ozone data were also transferred to the Punta Arenas MicroVAX II via a DECnet link.

5.2 Utilization of The Near-Real Time Telecommunications Network

As discussed in Section 2.4, a tri-continental network of dedicated lines and associated signal processing equipment was

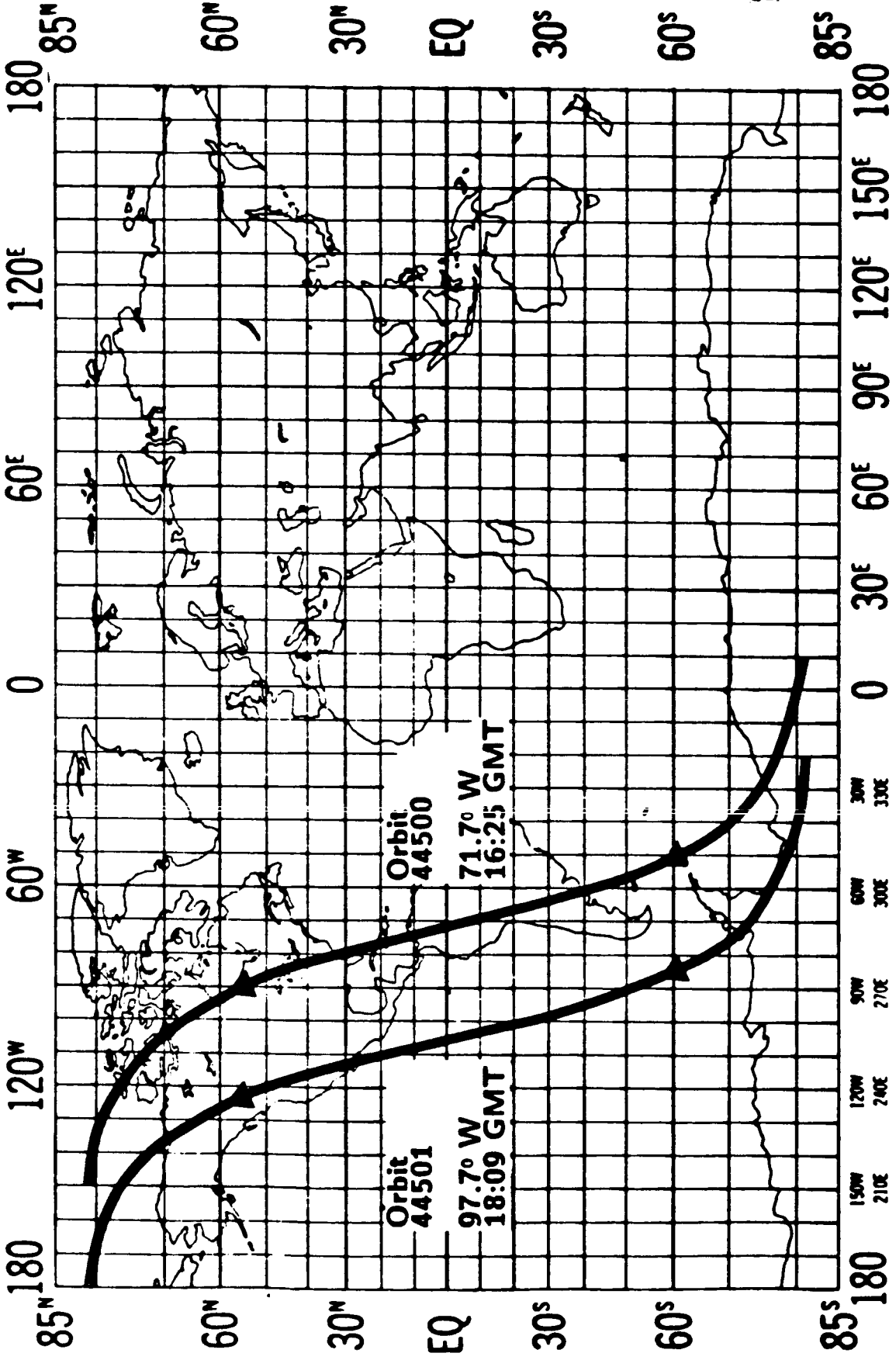

Figure 8. Subsatellite tracks produced from predictive ephemeris for orbit 44500-1 on August 17, 1987.

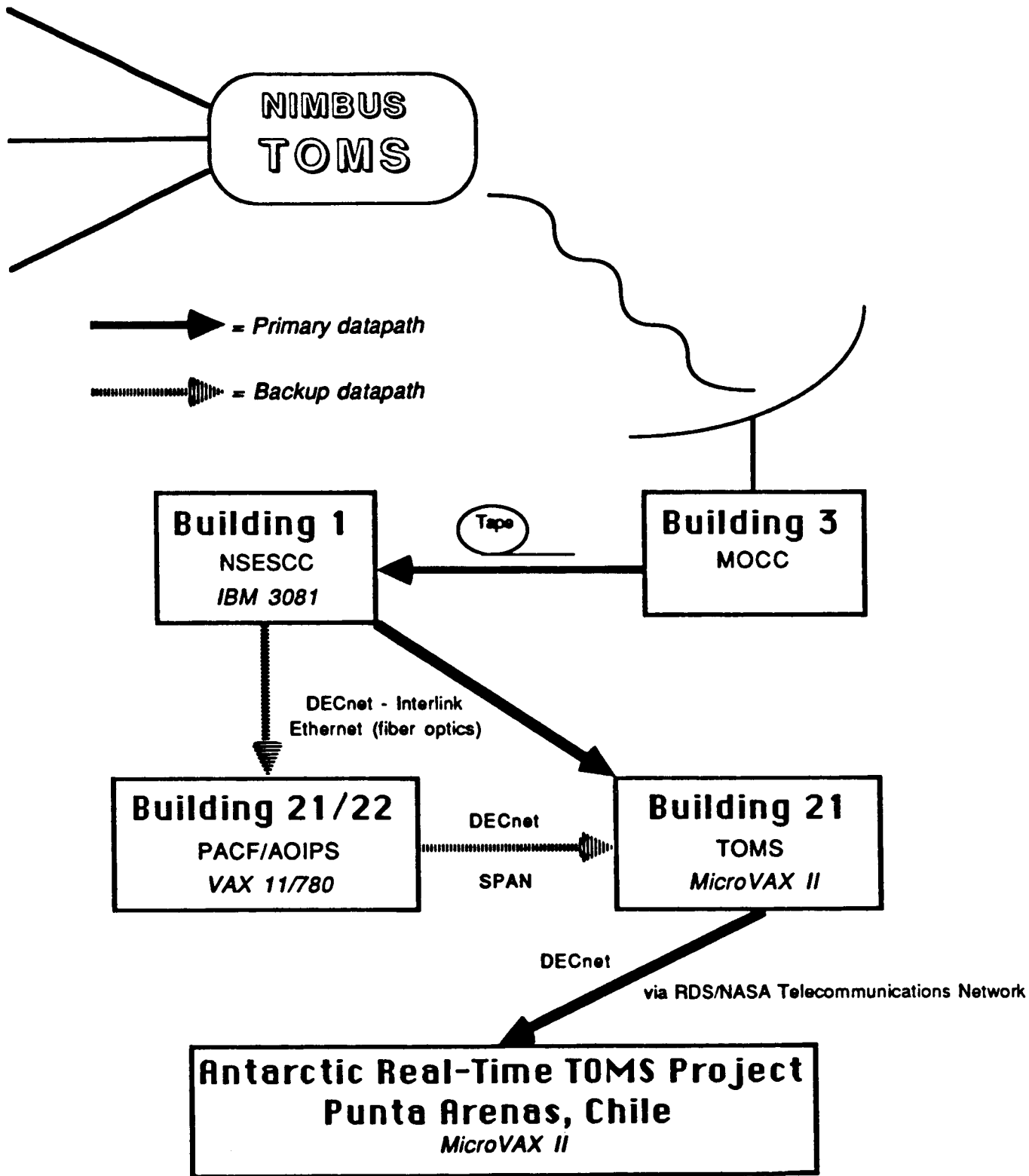

Figure 9. Real-time TOMS data flow and transfer during the 1987 Airborne Antarctic Ozone Experiment.

designed, installed, and operated to support the voice, facsimile, and digital data telecommunications requirements of the 1987 Antarctic Airborne Ozone experiment. The telecommunications network configuration (Figure 2) permitted meteorological forecast and analysis facsimile maps to be supplied to the operations centers at the NASA/GSFC and in Punta Arenas, Chile. Both the European Centre for Medium-Range Weather Forecasting (ECMWF) and the United Kingdom Meteorological Office (UKMO) supplied meteorological products in support of the experiment. The network also permitted general voice and facsimile communications between the Punta Arenas Communications Center, Europe (via the ECMWF and UKMO exchanges), and the United States (via the GSCF CBX-9000 exchange), and voice-only communications to Palmer Station in Antarctica (via the INMARSAT gateway).

As shown in Figure 9, the TOMS total ozone data sets were transferred to the MicroVAX II in Punta Arenas via the above-stated network using the DECnet protocol. Because of the dedicated nature of the lines, the high data rate (9.6 kbps), the 24-hour manning of the communications center in Punta Arenas, and the extremely reliable operation of the network as a whole, the TOMS data sets were routinely transferred to the investigators in Punta Arenas in an extremely timely manner. The near-real time orbital total ozone data and delayed hemispheric data were thus of the highest utility in directing the ER-2 and DC-8 aircraft by providing the locations of the ozone hole boundary and navigational information for the mission. The data sets also were used to support the project planning activities in general.

The ability of the network to provide numerical weather prediction charts to the mission forecaster and to provide TOMS total ozone data to the operations center in Punta Arenas were critical to the success of the campaign and were designated go/no-go criteria for the release of the research aircraft from the NASA/Ames Research Center (NASA/ARC, 1987). In view of the desired August 17 beginning of the experimental flight period, the project's go/no-go decision date was set at August 8. The mission criteria were satisfied on August 8 as required, and the DC-8 and ER-2 aircraft left NASA/Ames to fly to Punta Arenas.

5.3 Data Analysis and Presentation

Raw TOMS data, from the NASA/GSFC Nimbus Project, are converted into total ozone estimates and Earth-located by STX Corporation under contract to the NASA/GSFC Ozone Processing Team, after which the ungridded TOMS measurements are archived on the Ozone-T tape product. When gridded, the TOMS total ozone observations are stored on the GRIDTOMS archival tape product. During the experiment, the Ozone-T processing was conducted as soon as each orbit within the domain of interest was received at the GSFC Meteorological Operations Control Center (METOCC), while the GRIDTOMS processing was performed once per day on the most recent 24 hours of data. Thus, the orbital swath data were derived from the Ozone-T data sets, while the hemispheric charts were based on data

from the GRIDTOMS data sets. During the experiment, the near-real-time processing was accomplished by accessing the respective data sets, which resided in disk storage on the IBM 3081 in "virtual magnetic tape" format.

The hemispheric plots presented in the TOMS data atlas (Krueger et al., 1987) consist of a subset of a 91 by 72 element array located between 10° and 90° south latitude extracted from the GRIDTOMS tapes (Nimbus, 1986). The plots were produced using an interactive data analysis and graphics package, termed GEMPAK (desJardins and Petersen, 1985). GEMPAK requires input data to be gridded onto a uniform latitude/longitude grid. Since these data are now in such a format, no further processing is required prior to plotting. The advantages of using the reduced resolution data set are that all small data gaps are eliminated and the synoptic and planetary-scale features are clearly displayed. The disadvantage is that any mesoscale features present in the unfiltered TOMS data are eliminated.

The orbital total ozone data, tagged by the latitude and longitude of the IFOV center point, along with several other products, were extracted from the Ozone-T data set (Fleig et al., 1982) for the southern-hemisphere analysis domain and processed using GEMPAK. Because of storage limitations imposed by GEMPAK, measurements from every third scan line, and every third observation in that scan line, were extracted from the orbital swath data. The selected observations for each day were objectively analyzed within GEMPAK using two passes through a Barnes objective analysis routine. The grid spacing produced was 2° in latitude and 1.5° in longitude. Because of the excellent signal-to-noise characteristics of the TOMS total ozone data, the numerical convergence parameter (Koch et al., 1983) was set at 0.3, yielding a minimum of additional smoothing and the greatest detail in the final analysis. Figure 10 depicts a small portion of a single orbital swath from August 17, 1987 displaying digitally the ozone values prior to objective analysis. This orbit (number 44500) is the first of two orbits of Earth-located total ozone observations used to compose the objectively analyzed near-real-time ozone field for the day. The satellite track is from the bottom to the top of the figure, with each cross-track scan sweeping from right to left across the track. The data are unevenly distributed, with the greatest density of observations occurring near nadir (right), and the least out towards the Earth's limb (left). Figure 11 depicts the same area after the data have been objectively analyzed onto a uniform grid as described above. A more uniform density of total ozone values has been achieved. A minimum of 172 DU is achieved midway up the eastern coast of the Antarctic Peninsula, with a strong gradient to the west, north, and south. Comparing the analysis to the original data, we find general agreement. At the eastern base of the peninsula, an analyzed value of 235 DU compares well to the pre-analysis magnitude of 237 DU. At the tip of the peninsula, an analyzed magnitude of 230 DU is in good agreement with the 231 DU observation. However, slight differences are apparent. For example, the minimum value of the

ORIGINAL PAGE IS
OF POOR QUALITY.

Orbital (44500) TOMS Ozone (Dobson Units)

August 17, 1987

Figure 10. A sample of TOMS total ozone observations from portions of 36 scan lines during orbit 44500 of August 17, 1987.

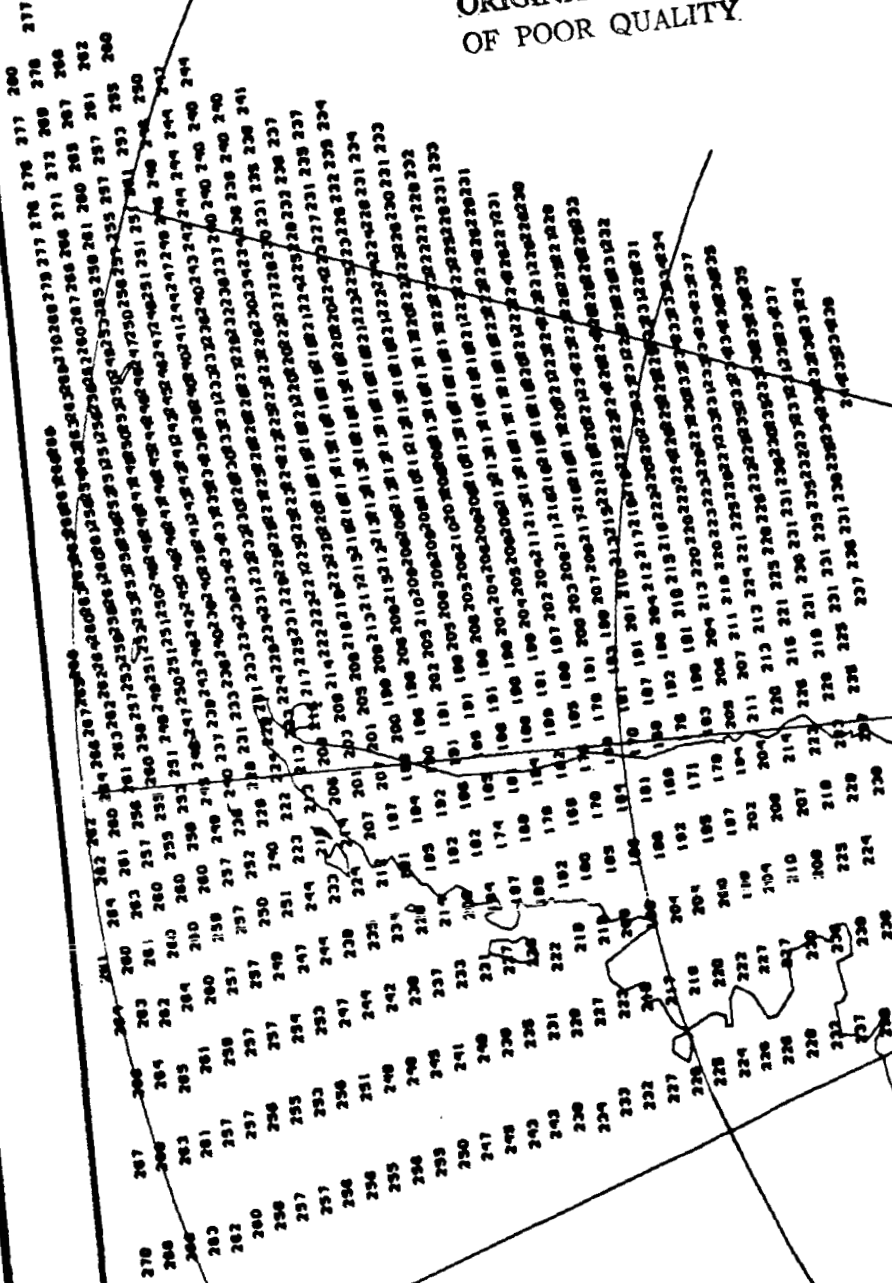

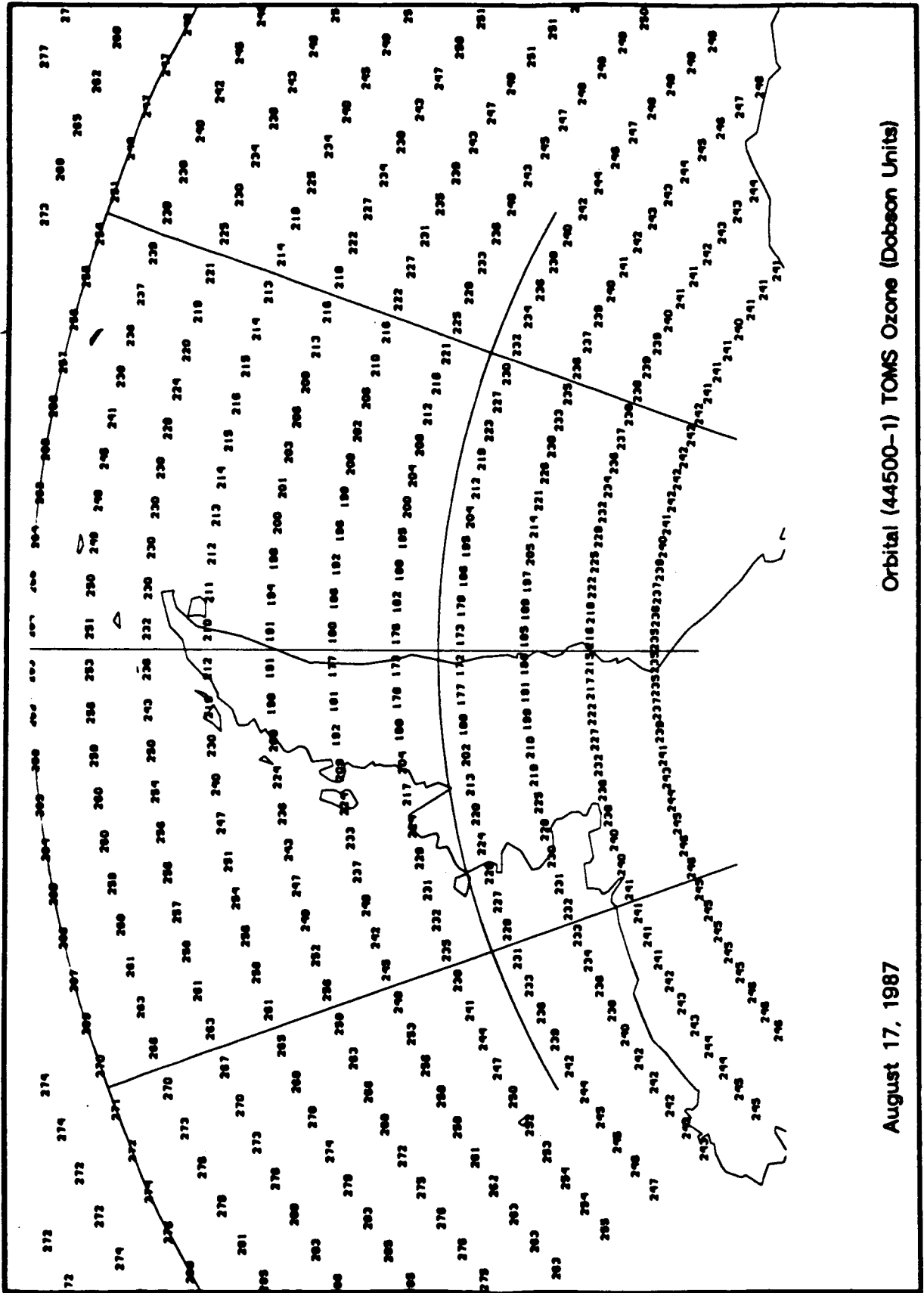

Orbital (44500-1) TMS Ozone (Dobson Units)

August 17, 1987

Figure 11. Objectively analyzed TMS total ozone data obtained from measurements taken during orbit 44500-1.

ungridded data from orbit 44500 is 161 DU at about 70°S, compared to 172 DU in the analysis. There are three reasons for this sort of discrepancy: (1) two orbits of data (44500-1) are used in the final analysis and, due in part to temporal variability, overlapping data from neighboring orbits are not perfectly in agreement; (2) a subset of the complete set of measurements are used, though in the objective analysis routine a measurement as low as 162 DU is retained from orbit 44501 (not shown); and (3) the Barnes scheme filters all high frequency modes with wavelengths close to and smaller than twice the average separation between nearest observations. Clearly (see Figure 14a), the final analysis of the total ozone distribution is faithful to the structure and magnitude of the original set of observations.

The daily orbital swath data consist of from two to three orbital segments located in the latitude range extending from 20°S through the southern terminator (near 75°S in mid-August through 90°S in late September), centered at approximately 70°W longitude, and covering Punta Arenas and the Palmer Peninsula of Antarctica. The precise domain differs from day to day due to the longitudinal differences in the subsatellite tracks. The orbital swaths displayed in the TOMS data atlas (Krueger et al., 1987) are precisely those produced in near real time in support of the experiment.

6. TOMS TOTAL OZONE DATA

6.1 Chronology of the Experiment

To facilitate the use of the TOMS total ozone data, in particular the sets of orbital and hemispheric maps displayed in the TOMS data atlas (Krueger et al., 1987), a chronology of relevant events during the experiment was prepared. Here, we do not consider every day during the period of TOMS coverage, but instead emphasize here the salient points in the data set. In addition, all flights of the ER-2 and DC-8 research aircraft are noted explicitly.

AUGUST 2, 1987

This is the first day for which a TOMS hemispheric image is obtained in near-real-time. The lowest ozone values are present west of the Antarctic Peninsula off the Getz ice shelf. Minimum values of between 200 and 225 Dobson units (DU) are observed.

AUGUST 3, 1987

A large mid-latitude total ozone maximum propagates eastward to between western Australia and Antarctica. Values in excess of 425 DU are recorded.

AUGUST 6, 1987

A small area of minimum total ozone values, less than 250 DU, appears just east of Cape Horn, while the maximum south of Australia exceeds 475 DU.

AUGUST 8, 1987

The go/no-go mission criteria are satisfied as the real-time TOMS system and the associated communications network become fully operational. Near-real-time TOMS total ozone from GSFC and numerical weather prediction forecast charts from UKMO and ECMWF are received in Punta Arenas. The ER-2 and DC-8 aircraft are released for deployment in Punta Arenas. The large maximum formed on August 3rd drifts slowly eastward and merges with a second maximum off Cape Adare.

AUGUST 10, 1987

The small minimum formed on August 6th drifts south and east toward the coast just east of Halley Bay and expands in size.

AUGUST 12, 1987

ER-2 Flight (i) from NASA/AMES to Panama. Observations were made, but these are not officially part of the experiment. The previous total ozone minimum washes out and another area of low total ozone amount appears at the base of the Antarctic peninsula, with total ozone values less than 225 DU measured. This region expands slightly in size on August 13th and then vanishes on August 14th.

AUGUST 14, 1987

ER-2 Flight (ii) from Panama to Puerto Montt, Chile, with observations. A dominant wavenumber-5 pattern has formed at 50°S, with maxima centered over Chile, southwest of Cape Hope, southeast of Madagascar, south of Australia, and in the central Pacific Ocean.

AUGUST 15, 1987

ER-2 Flight (iii) from Puerto Montt to Punta Arenas, Chile. A new minimum area develops, again at the base of the Antarctic peninsula, and is accompanied by a secondary minimum near the Mawson coast. Both minima have values below 225 DU.

AUGUST 16, 1987

Minimum values in the peninsular "mini-hole" drop below 200 DU for the first time. Orbital imagery suggests the possibility of a lee wave type of pattern in the ozone distribution over the western Weddell Sea.

AUGUST 17, 1987

ER-2 Flight #1. The first official flight of the experiment. The mini-hole persists just east of the peninsula, with a slight increase in area, and with central values of less than 175 DU.

AUGUST 18, 1987

ER-2 Flight #2.

AUGUST 19, 1987

DC-8 Flight (i) makes observations on flight from NASA/AMES to Costa Rica.

AUGUST 22, 1987

DC-8 Flight (ii) from Costa Rica to Punta Arenas. The August 15 minimum near the Weddell Sea has begun to propagate eastward at about 30° longitude per day.

AUGUST 23, 1987

ER-2 Flight #3. During the past week, several minima areas of minimum total ozone wax and wane along the edges of the continent with values between 200 and 225 DU.

AUGUST 28, 1987

ER-2 Flight #4. DC-8 Flight #1. In the last day or two, a quasi-stationary expanding area of low total ozone values develops over the base of the peninsula.

AUGUST 30, 1987

ER-2 Flight #5. DC-8 Flight #2. The end of August finds the area of minimum total ozone in the vicinity of the Weddell Sea and the Antarctic peninsula.

SEPTEMBER 1, 1987

The month begins with one prominent total ozone minimum centered over the base of the Antarctic peninsula. The total ozone values are less than 225 DU over a small area near the center.

SEPTEMBER 2, 1987

ER-2 Flight #6. DC-8 Flight #3. There is a dramatic appearance of a secondary minimum of total ozone on the opposite side of the Antarctic continent and centered between Vostok and the Shackleton Ice Shelf.

SEPTEMBER 4, 1987

ER-2 Flight #7. There are some areas of merged minima surrounding the western half of the Antarctic continent. No values below 200 DU presently exist.

SEPTEMBER 5, 1987

DC-8 Flight #4. A sudden drop in minimum total ozone value near the eastern base of the Antarctic peninsula occurs. Values are now noted below 175 DU. Half of Antarctica is now covered with total ozone magnitudes of less than 225 DU. This is now purported to be the authentic beginning of the 1987 Antarctic ozone hole.

SEPTEMBER 8, 1987

DC-8 Flight #5.

SEPTEMBER 9, 1987

ER-2 Flight #8. The region of lowest total ozone abundances has drifted away from the peninsula, across portions of the Weddell Sea and onto the continent in the vicinity of the Greenwich meridian and latitude 85°S. The lowest total ozone values in the hole are now below 175 DU.

SEPTEMBER 11, 1987

DC-8 Flight #6. Pronounced total ozone maxima in excess of 425 DU circle the hole at 50°S.

SEPTEMBER 14, 1987

DC-8 Flight #7. By now, practically the entire Antarctic continent is covered with total ozone magnitudes of less than 225 DU, with half of the continent experiencing values below 200 DU. Persistent regions with less than 175 DU are present.

SEPTEMBER 16, 1987

ER-2 Flight #9. DC-8 Flight #8. The hole has continued to expand considerably and become more zonally symmetric during the past week. The lowest values over the continent continue to be in the range of 150 to 175 DU. The mid-latitude ozone gradient at 60°S has intensified markedly around three-quarters of the southern hemisphere.

SEPTEMBER 18, 1987

The ozone hole is now very zonally symmetric and is centered almost directly over the south pole. No values below 150 DU have been noted as yet.

SEPTEMBER 19, 1987

DC-8 Flight #9.

SEPTEMBER 20, 1987

ER-2 Flight #10. The hole becomes more organized over the eastern half of the Antarctic continent.

SEPTEMBER 21, 1987

ER-2 Flight #11. DC-8 Flight #10. Polar night ends.

SEPTEMBER 22, 1987

ER-2 Flight #12 is the last flight for this aircraft for this experiment. The ozone hole has shifted its orientation and, for the first time this year, values of total ozone below 150 DU were recorded by TOMS.

SEPTEMBER 24, 1987

DC-8 Flight #11.

SEPTEMBER 26, 1987

DC-8 Flight #12.

SEPTEMBER 29, 1987

DC-8 Flight #13. Both aircraft leave Punta Arenas. The ER-2 flies to Puerto Montt and the DC-8 overflies Antarctica on its way to Christ Church, New Zealand. A significant portion of Antarctica is covered with total ozone amounts of less than 150 DU.

SEPTEMBER 30, 1987

The ozone hole at the end of the month is symmetric and centered near the south pole. Values between 125 and 150 DU continue to be recorded.

OCTOBER 1, 1987

The ER-2 departs Puerto Montt for Panama. The month begins with a slightly egg-shaped ozone hole with a long axis oriented along a line from Rio de Janeiro to Melbourne. The minimum values remain below 150 DU and cover an increasingly larger domain. By this day, all latitudes south of 80°S possess total ozone amounts of less than 150 DU.

OCTOBER 2, 1987

The DC-8 departs Christ Church for Hawaii.

OCTOBER 3, 1987

The ER-2 returns to NASA/AMES from Panama.

OCTOBER 4, 1987

The DC-8 returns to NASA/AMES from Hawaii.

OCTOBER 5, 1987

On this day, the total ozone amount reached its all-time lowest recorded value of 109 DU. The orientation of the ozone hole shifted in such a way that its long axis now lies along the Greenwich meridian. The hole remains very symmetrical, and its center is near 87 degrees south. The mid-latitude gradient of total ozone is extremely steep and quite uniform around the entire Antarctic continent.

OCTOBER 10, 1987

The axis of the ozone hole continues to rotate in a clockwise manner around the hemisphere. The minimum values at this time are everywhere above 125 DU.

OCTOBER 15, 1987

The total ozone imagery on this date shows a very well developed horn-shaped maximum in mid-latitudes between Australia and Antarctica. Values of total ozone in this maximum exceed 450 DU. Meanwhile, there has been very little rotation of the hole's axis during the past five days.

OCTOBER 16, 1987

In the center of the ozone hole, near the South Pole, minimum values below 125 DU again appear. These persist only until October 18.

OCTOBER 23, 1987

The long axis of the egg-shaped ozone hole is oriented along the 90th meridian and the large maximum values of just a few days before have relaxed considerably. The total ozone pattern on this date just begins to erode.

OCTOBER 24, 1987

There now appears to be a definite intrusion of higher latitude air into the ozone hole on its western flank. The intrusion resembles the tongues of dry air which spiral into the center of mid-latitude cyclones.

OCTOBER 26, 1987

The ozone hole continues to erode slowly away. Meanwhile, the total ozone maxima on either side of the hole begin again to rotate from west to east around the central vortex. These maxima were previously relatively stationary.

OCTOBER 31, 1987

The central portion of the ozone hole has shrunk to its smallest area so far this month. Values of total ozone less than 150 DU occur in a very small area between the Ross ice shelf and the South Pole.

NOVEMBER 1, 1987

The area of total ozone values less than 150 DU breaks up into five much smaller areas.

NOVEMBER 8, 1987

The ozone hole, during the past week, remains unusually stable. Areas of maximum total ozone continued to rotate east to west around the hole and the strong ozone gradients persist in mid-latitudes.

NOVEMBER 13, 1987

Almost two weeks into the month of November, the ozone hole maintains its shape and size. Only the minimum values have increased slowly. For the first time during the past month, minimum values exceeded 150 DU. In previous years the ozone hole was not nearly so persistent and had usually shown a good deal of dissipation by this time.

6.2 Latitudinal Cross-Sections

Figures 12a-d are cross-sections across the south pole and illustrate the development of the ozone hole in the southern hemisphere during the 1987 Airborne Antarctic Ozone Experiment. The abscissa of these plots represents a cross-section (along the 70°W and 110°E longitudes), beginning at 20°S, 70°W, through the south pole, to 20°S, 110°E. Figure 12a presents four curves, each an average for eight days in August. Figures 12b and 12c present a similar display for September and October. Figure 12d is a cross-section for a single day, October 5, 1987, during which the lowest ozone values were observed for this season.

From Figure 12a it can be seen that ozone levels reach a maximum at mid-latitudes, dropping off toward the pole and the equator. Since the immediate polar region is still in 24-hour darkness, no TOMS total ozone measurement is obtained. Although the poleward minima appear to be slightly lower than those at the equator, no

pronounced "hole" is yet apparent. The mid-latitude maxima appear to increase somewhat over time, although the trend is inconsistent. No discernible trend exists in the polar minima for this month.

Progressing through September (Figure 12b), one is able to see the hole in the total ozone field develop. The trend, especially at 80°S 110°E, refutes any suggestion that the ozone hole was present all along, only becoming observable as the pole was illuminated. The total ozone gradient, especially near 60°S 110°E, becomes pronounced. There does not appear to be any trend in the mid-latitude maxima worthy of note.

In October (Figure 12c), much of the longitudinal symmetry observed in August and September is perturbed. While the minimum total ozone values exhibit little change, there is a pronounced shifting of the center of the hole southward along 70°W and northward along 110°E. In a two-dimensional view (see Section 3.5), this corresponds to a shifting of the major axis of the then elliptically shaped ozone hole. In addition, along 110°E, the maxima are persistently higher and the gradient steeper than along 70°W. This feature is also evident in the individual polar charts for the period. The maxima along 110°E seem to diminish over time, due in part to a rotation in the major axis of the pattern. Figure 12d shows the pattern as it appeared on October 5, 1987, the amplitude when the total ozone hole was most pronounced, and the lowest total ozone measurements for the year were recorded by TOMS.

6.3 Time Series at Locations of Interest

Time series of TOMS total ozone estimates have been constructed for a set of eleven locations in Antarctica. A similar time series for the experiment's base of operations in Punta Arenas was also produced. A list of the selected locations, and their coordinates, is provided in Table 1. The time series incorporate daily gridded measurements from the southern-hemispheric grids (Section 6.5), and are extracted from that 2° (latitude) by 5° (longitude) grid element within which each station resides. At the mean latitude of 70°S, this corresponds to spatial average over an area of 222 km by 189 km. Table 2 presents the time series for the period August 1 through November 15, 1987. Note that Palmer Station and Faraday Station, located some 50 km apart, fall within the same grid element and are assigned the same total column ozone values. Of course, a number of the stations are located south of the Antarctic circle and experience 24-hour night during a portion of the experiment. During these periods, the TOMS total ozone estimates at these stations, which include Amundsen-Scott, Halley Bay, McMurdo Sound, and Vostok, are not available.

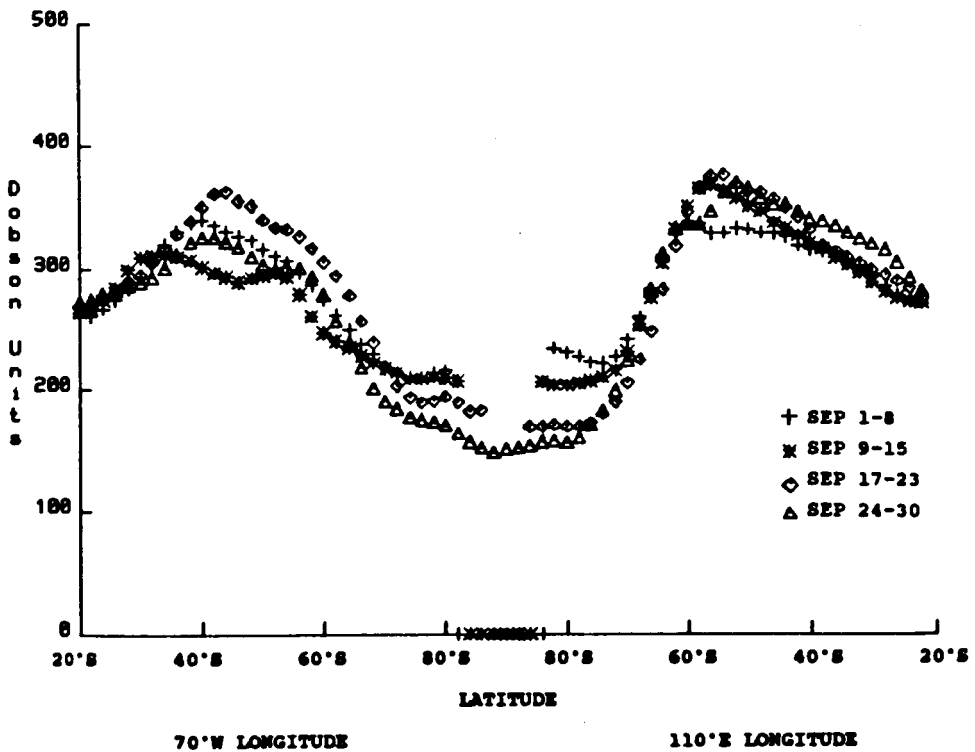
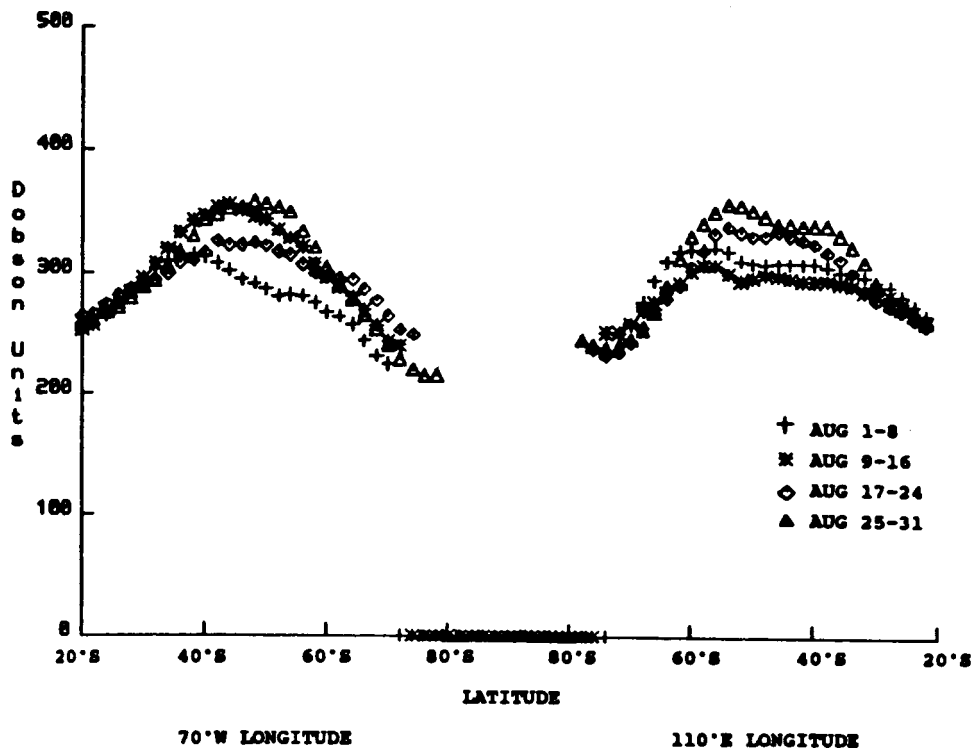

Figures 12 a-b. Cross-sections of TOMS total ozone measurements along the 70°W and 110°E longitudes across the south pole for four periods during (a) August 1987 and (b) September 1987.

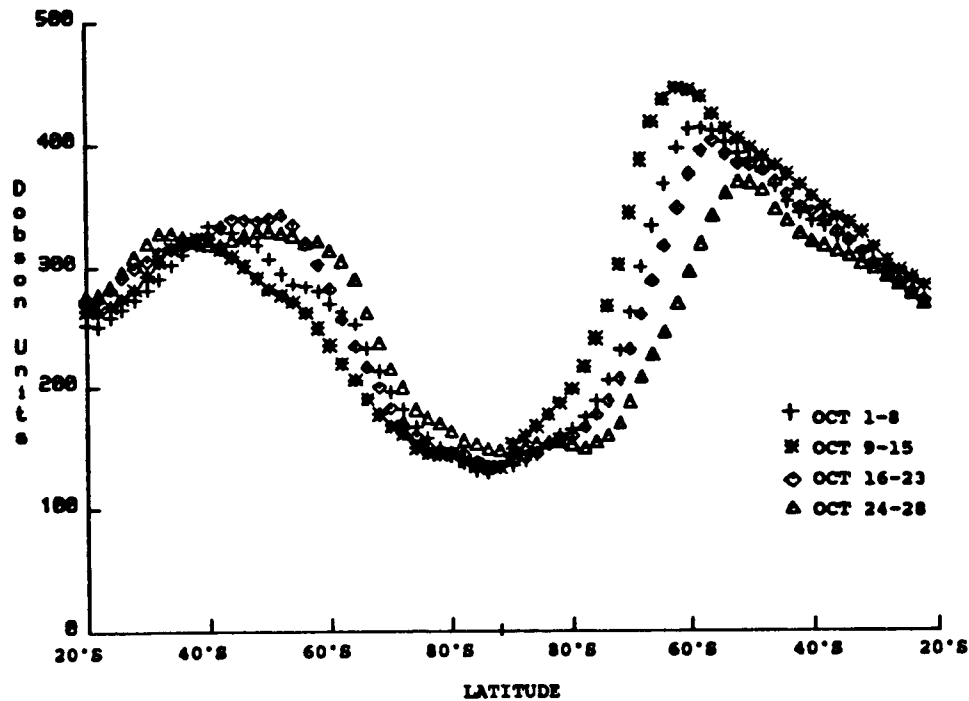

70°W LONGITUDE

110°E LONGITUDE

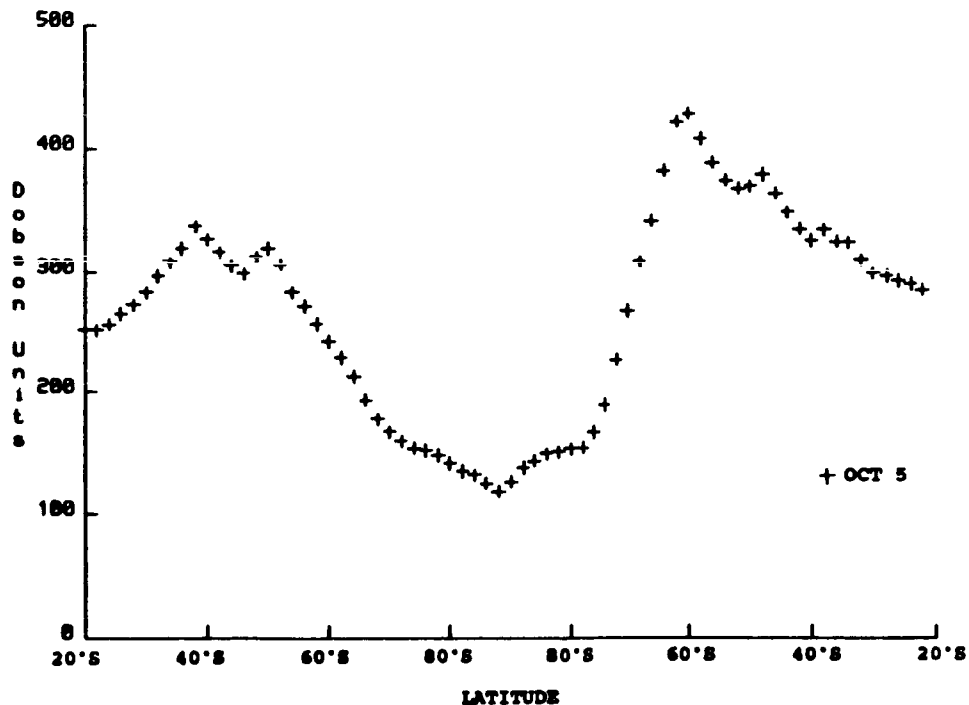

70°W LONGITUDE

110°E LONGITUDE

Figures 12 c-d. Cross-sections of TOMS total ozone measurements along the 70°W and 110°E longitudes across the south pole for (c) four periods during October 1987 and (d) October 5, 1987.

Table 1

Selected Locations for TOMS Total Ozone Time Series

<u>Location</u>	<u>Abbreviation</u>	<u>Latitude</u>	<u>Longitude</u>
Amundsen-Scott	SPO	90°00'S	00°00'W
B.A. Vice Comodoro Marambio	MAR	64°14'S	56°43'W
Davis	DAV	68°36'S	78°00'E
Dumont D'Urville	DUD	66°42'S	140°00'E
Faraday Station, Argentine Islands	FAR	65°15'S	64°16'W
Halley Bay	HAL	75°30'S	26°39'W
McMurdo	MCM	77°51'S	166°40'E
Molodeznaja	MOL	67°42'S	45°54'E
Palmer Station	PAL	64°46'S	64°04'W
Punta Arenas	PUN	53°02'S	70°51'W
Syowa	SYO	69°00'S	39°36'E
Vostok	VOS	78°30'S	106°54'E

Table 2

Time Series of Daily Total Ozone Values (DU)

<u>DAY</u>	<u>DATE</u>	<u>SPO</u>	<u>FAR</u>	<u>HAL</u>	<u>MAR</u>	<u>MCM</u>	<u>PAL</u>	<u>PUN</u>	<u>DAV</u>	<u>SYO</u>	<u>VOS</u>	<u>MOL</u>	<u>DUM</u>
213	AUG 01	0	240	0	261	0	240	273	288	246	0	252	270
214	AUG 02	0	237	0	252	0	237	312	258	237	0	240	318
215	AUG 03	0	249	0	261	0	249	330	246	237	0	237	330
216	AUG 04	0	240	0	255	0	240	261	237	243	0	243	303
217	AUG 05	0	243	0	255	0	243	276	243	243	0	246	318
218	AUG 06	0	234	0	255	0	234	255	249	249	0	261	303
219	AUG 07	0	0	0	231	0	0	0	255	237	0	240	297
220	AUG 08	0	252	0	249	0	252	327	249	246	0	249	276
221	AUG 09	0	264	0	264	0	264	363	240	258	0	255	279
222	AUG 10	0	270	0	288	0	270	327	252	255	0	249	276
223	AUG 11	0	291	0	282	0	291	360	258	252	0	252	249
224	AUG 12	0	270	0	288	0	270	372	255	246	0	252	273
225	AUG 13	0	249	0	261	0	249	315	267	234	0	237	261
226	AUG 14	0	261	0	255	0	261	306	252	243	0	243	270
227	AUG 15	0	243	0	258	0	243	327	237	231	0	225	261
228	AUG 16	0	219	0	246	0	219	300	231	240	0	243	261
229	AUG 17	0	201	0	222	0	201	282	255	237	0	231	273
230	AUG 18	0	234	0	237	0	234	279	228	240	0	237	255
231	AUG 19	0	216	0	222	0	216	240	243	237	0	243	261
232	AUG 20	0	285	264	276	0	285	291	219	228	0	234	237
233	AUG 21	0	309	258	300	0	309	393	243	258	0	258	249
234	AUG 22	0	339	264	351	0	339	330	255	252	0	252	270
235	AUG 23	0	324	258	354	0	324	348	258	231	0	240	255
236	AUG 24	0	303	267	321	0	303	351	243	234	0	237	243
237	AUG 25	0	291	264	312	0	291	372	240	219	0	216	279
238	AUG 26	0	273	261	291	237	273	357	240	231	243	240	282
239	AUG 27	0	276	240	291	237	276	342	243	240	246	231	258
240	AUG 28	0	276	237	291	237	276	345	237	249	255	255	255
241	AUG 29	0	279	213	297	264	279	348	264	255	237	261	249
242	AUG 30	0	243	222	267	240	243	333	252	249	240	252	285
243	AUG 31	0	231	219	246	240	231	339	246	246	246	255	273
244	SEP 01	0	240	219	267	258	240	282	246	249	252	243	264
245	SEP 02	0	255	228	276	255	255	321	231	237	216	234	261
246	SEP 03	0	255	222	264	231	255	306	228	240	207	231	252
247	SEP 04	0	237	216	267	210	237	309	237	234	234	231	234
248	SEP 05	0	204	222	225	216	204	288	243	240	246	237	249
249	SEP 06	0	213	183	222	240	213	306	237	258	228	234	243
250	SEP 07	0	249	192	267	225	249	309	231	243	228	252	282
251	SEP 08	0	240	192	255	228	240	306	249	228	225	240	288
252	SEP 09	0	225	207	225	234	225	297	261	222	219	222	294
253	SEP 10	0	225	192	228	240	225	282	237	222	237	231	285
254	SEP 11	0	225	180	231	240	225	270	225	219	219	228	276
255	SEP 12	0	216	177	225	231	216	282	219	225	213	225	324
256	SEP 13	0	219	189	222	219	219	330	219	213	192	225	303
257	SEP 14	0	234	192	240	204	234	309	207	213	180	222	267
258	SEP 15	0	228	189	228	192	228	270	213	225	162	228	246
259	SEP 16	0	264	207	279	180	264	321	237	219	171	231	234

Table 2 (continued)

Time Series of Daily Total Ozone Values (DU)

<u>DAY</u>	<u>DATE</u>	<u>SPO</u>	<u>FAR</u>	<u>HAL</u>	<u>MAR</u>	<u>MCM</u>	<u>PAL</u>	<u>PUN</u>	<u>DAV</u>	<u>SYO</u>	<u>VOS</u>	<u>MOL</u>	<u>DUM</u>
260	SEP 17	0	252	180	267	180	252	387	216	204	189	207	240
261	SEP 18	0	243	186	261	198	243	390	204	198	183	204	252
262	SEP 19	0	246	198	258	183	246	354	219	183	177	189	267
263	SEP 20	0	255	180	261	186	255	312	201	177	165	180	249
264	SEP 21	0	282	192	285	186	282	282	198	198	147	189	255
265	SEP 22	0	240	189	282	180	240	294	201	198	147	210	252
266	SEP 23	0	210	177	231	174	210	294	225	216	168	249	237
267	SEP 24	0	201	168	204	165	201	276	258	210	165	261	273
268	SEP 25	0	183	177	189	177	183	285	261	195	153	231	270
269	SEP 26	153	192	177	192	162	192	273	249	186	168	207	237
270	SEP 27	147	204	174	219	177	204	270	201	192	162	210	252
271	SEP 28	141	219	165	216	174	219	327	213	219	147	258	240
272	SEP 29	132	234	165	249	162	234	339	261	198	144	255	180
273	SEP 30	117	219	168	231	162	219	312	249	183	147	216	234
274	OCT 01	123	210	153	219	144	210	303	237	177	159	204	273
275	OCT 02	132	225	153	198	153	225	309	225	201	153	237	267
276	OCT 03	135	255	147	258	141	255	318	243	207	150	255	231
277	OCT 04	135	237	156	264	150	237	297	276	174	147	195	252
278	OCT 05	117	183	150	183	144	183	285	270	177	153	186	225
279	OCT 06	120	258	135	240	156	258	261	264	156	192	159	234
280	OCT 07	138	237	138	246	180	237	246	204	165	192	168	369
281	OCT 08	144	177	138	195	225	177	288	201	153	168	165	405
282	OCT 09	132	162	138	168	210	162	285	228	186	177	201	387
283	OCT 10	144	174	141	186	234	174	273	291	183	204	204	390
284	OCT 11	156	180	138	195	249	180	264	261	177	225	210	444
285	OCT 12	147	174	144	189	255	174	270	270	174	183	195	444
286	OCT 13	141	201	135	183	189	201	264	273	186	189	216	360
287	OCT 14	138	198	141	198	195	198	255	285	198	192	216	384
288	OCT 15	141	201	150	228	207	201	297	252	177	195	195	429
289	OCT 16	141	189	150	189	228	189	276	192	198	183	234	426
290	OCT 17	138	189	150	198	246	189	321	198	198	171	228	417
291	OCT 18	135	177	153	183	213	177	327	234	198	159	246	351
292	OCT 19	141	210	141	219	195	210	336	258	183	153	207	354
293	OCT 20	138	189	153	198	177	189	363	204	165	162	183	342
294	OCT 21	132	234	159	240	180	234	333	180	207	156	204	345
295	OCT 22	129	267	153	297	186	267	366	186	216	138	237	315
296	OCT 23	126	249	150	276	195	249	342	195	171	135	180	294
297	OCT 24	147	216	162	237	186	216	327	171	177	144	192	261
298	OCT 25	150	210	174	225	177	210	291	171	231	159	234	255
299	OCT 26	144	189	183	207	162	189	306	219	243	144	282	255
300	OCT 27	141	315	165	327	150	315	348	243	240	153	291	237
301	OCT 28	144	396	177	399	162	396	348	240	219	147	264	207
302	OCT 29	141	393	180	372	168	393	354	261	228	159	255	213
303	OCT 30	144	381	210	363	165	381	369	282	201	168	207	213
304	OCT 31	147	408	270	393	165	408	384	231	198	153	192	255

Table 2 (continued)

Time Series of Daily Total Ozone Values (DU)

<u>DAY</u>	<u>DATE</u>	<u>SPO</u>	<u>FAR</u>	<u>HAL</u>	<u>MAR</u>	<u>MCM</u>	<u>PAL</u>	<u>PUN</u>	<u>DAV</u>	<u>SYO</u>	<u>VOS</u>	<u>MOL</u>	<u>DUM</u>
305	NOV 01	153	309	246	345	171	309	390	210	204	150	198	270
306	NOV 02	153	351	201	345	159	351	360	210	234	159	237	207
307	NOV 03	153	348	207	384	156	348	372	216	234	162	258	216
308	NOV 04	159	237	198	294	159	237	342	246	213	162	264	234
309	NOV 05	159	198	171	216	165	198	0	282	201	162	225	237
310	NOV 06	150	204	168	207	168	204	303	261	210	174	240	315
311	NOV 07	150	222	168	240	180	222	360	270	225	189	249	318
312	NOV 08	156	258	174	276	192	258	375	300	213	204	249	351
313	NOV 09	153	264	168	309	207	264	318	300	204	192	249	402
314	NOV 10	150	225	225	246	198	225	294	255	222	183	222	366
315	NOV 11	153	204	195	216	192	204	285	219	315	180	294	357
316	NOV 12	165	222	186	267	192	222	336	243	309	171	354	324
317	NOV 13	168	210	168	234	192	210	330	243	264	174	288	252
318	NOV 14	162	255	165	252	180	255	336	249	219	177	252	234
319	NOV 15	174	267	168	276	183	267	369	216	213	174	228	282
320	NOV 16	177	261	174	285	198	261	384	228	216	159	249	282
321	NOV 17	168	336	195	324	177	336	348	321	210	165	279	285
322	NOV 18	168	321	222	369	180	321	372	381	231	189	300	255
323	NOV 19	177	291	195	333	189	291	354	369	222	276	264	369
324	NOV 20	183	363	195	372	234	363	339	318	228	261	231	369
325	NOV 21	186	300	210	345	237	300	330	240	207	222	222	354
326	NOV 22	180	258	216	288	243	258	312	228	267	216	270	372
327	NOV 23	177	213	216	213	255	213	288	258	336	189	339	372
328	NOV 24	183	213	213	222	219	213	291	336	354	195	369	300
329	NOV 25	192	207	207	216	207	207	282	369	354	255	393	243
330	NOV 26	207	213	195	237	240	213	321	372	330	315	348	339
331	NOV 27	276	210	192	225	303	210	336	372	312	363	333	378
332	NOV 28	303	222	195	240	375	222	312	378	279	372	306	381
333	NOV 29	285	234	210	267	396	234	336	381	243	360	264	381
334	NOV 30	279	246	198	276	393	246	288	357	231	363	234	402

Punta Arenas

Punta Arenas, Chile, located near Cape Horn in extreme southern Chile at 53°S, lies outside the boundary of the ozone hole throughout the 1987 experiment. The daily TOMS total ozone estimates fluctuate between 240 DU and 393 DU (Figure 13a). The minimum of 240 DU on August 19 occurs as a result of an in-phase relationship between two total ozone minima: one quasi-stationary minimum over the Antarctic Peninsula, and a second component related to an eastward propagating wave. Interestingly, the maximum value for the period occurs only two days later as a strong eastward-propagating center moves over southern Chile.

B.A. Vice Comodoro Marambio

The Marambio station is located at 64°S, just off the tip of the Antarctic Peninsula. The daily TOMS total-column ozone amounts at Marambio range from 168 to 399 DU (Figure 13b). The time series exhibits some very interesting fluctuations. Consider the minimum of August 16-19 (days 228-231). Referring to the corresponding maps, the short-lived minimum is caused by the presence of a "mini-hole" over the peninsula, a situation which recurs on about September 5 (day 248), as another relatively small minimum moves over the station. The minima of September 23-26 (days 266-269) and October 8-12 (days 281-285), however, are caused by the growth of the ozone hole boundary beyond the tip of the peninsula, so that Marambio is located to the south of the steep total-ozone gradient. Similarly, the periodic maxima such as during the period of September 16-22 (days 259-265) are caused by a local southward movement of the hole's boundary, such that the station is located within (or to the north of) the total ozone gradient. Abruptly, on October 28 (day 301), the total ozone measurements over the location reached their highest values for the period.

Palmer Station/Faraday Station

The Palmer and Faraday stations, located at 65°S, lie within the same grid element and are considered jointly. The total ozone data for this location (Figure 13c) are closely correlated with, though independent of, the TOMS measurements taken over Marambio.

Dumont D'Urville Station

The Dumont D'Urville station is located at 67°S on the edge of Antarctica almost 180° in longitude away from the Antarctic Peninsula. During the experiment, the station can be observed to lie within the steep gradient associated with the boundary of the ozone hole. As such, the day-to-day fluctuations in total ozone encountered (Figure 13d) are caused by slight adjustments in the position of the ozone-hole boundary. However, on about October 7 (day 280), a 90° rotation in the major axis of the (by then) elliptical ozone hole, coupled with a 10° latitudinal shift in the hole's center causes the total ozone measurements for this location to rise dramatically. By the end of October, another

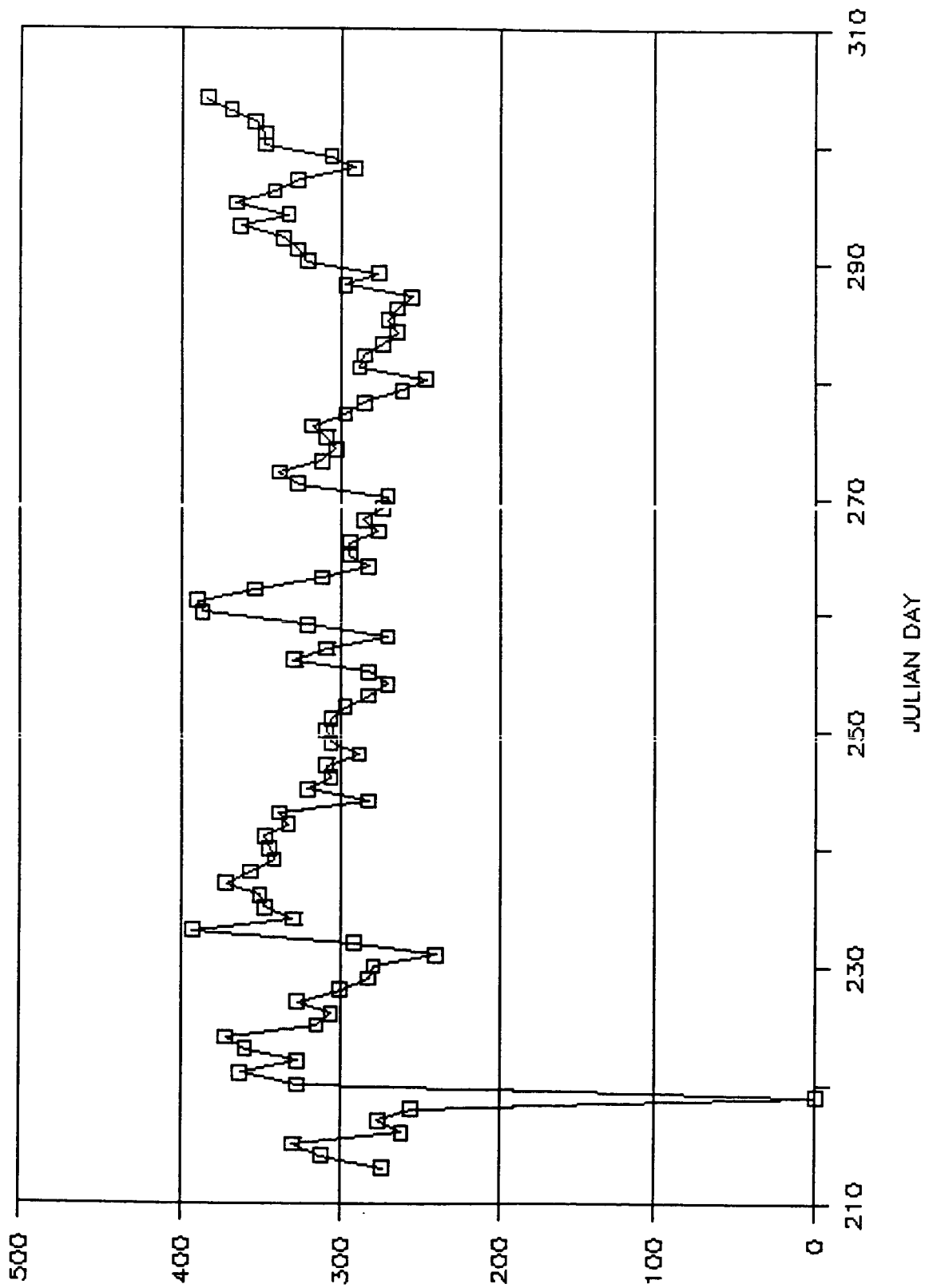

Figure 13a. Daily TOMS Total Ozone Values over Punta Arenas (DU).

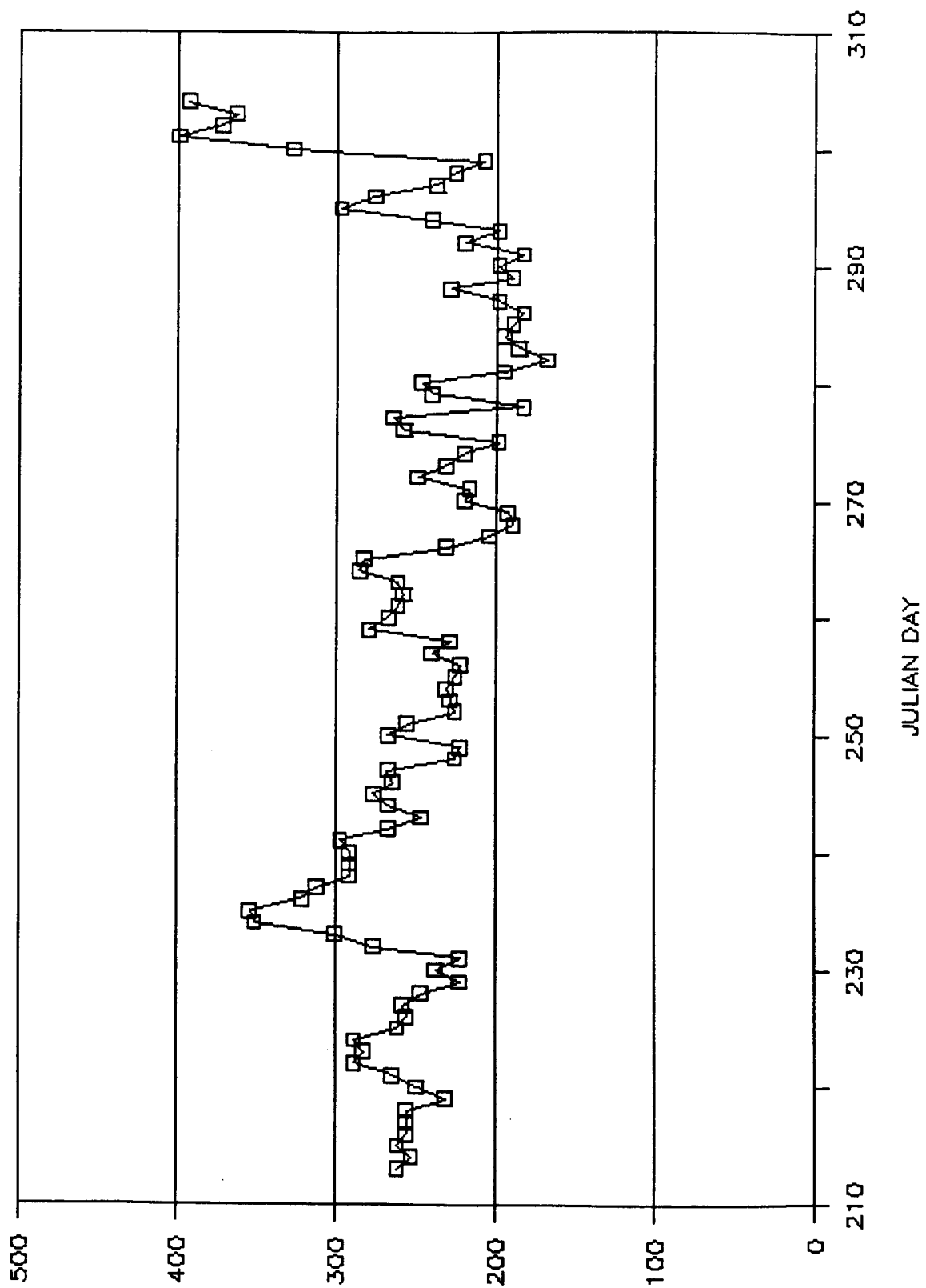

Figure 13b. Daily TOMS Total Ozone Values over Marambio (DU).

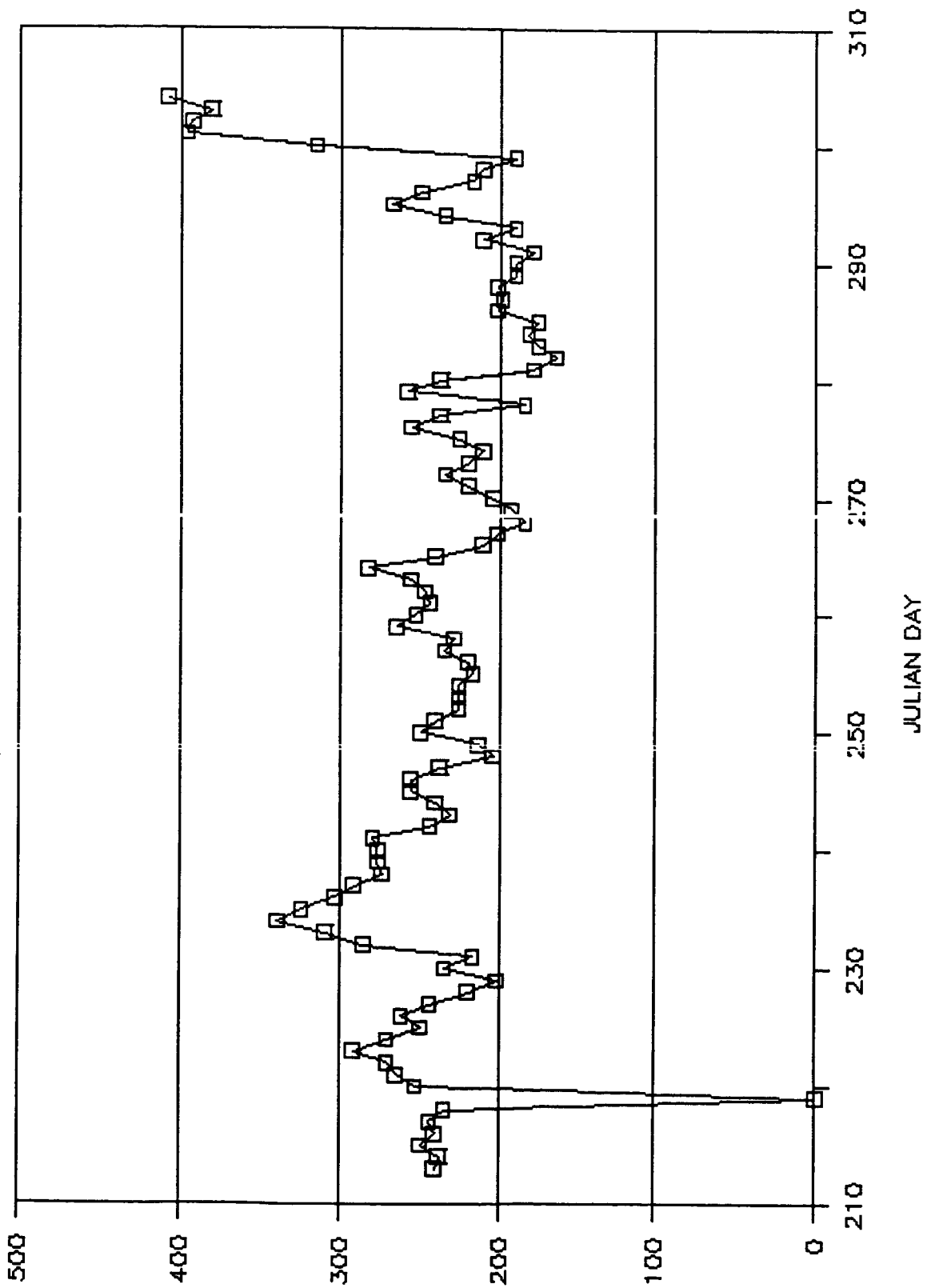

Figure 13c. Daily TOMS Total Ozone Values over Palmer Station (DU).

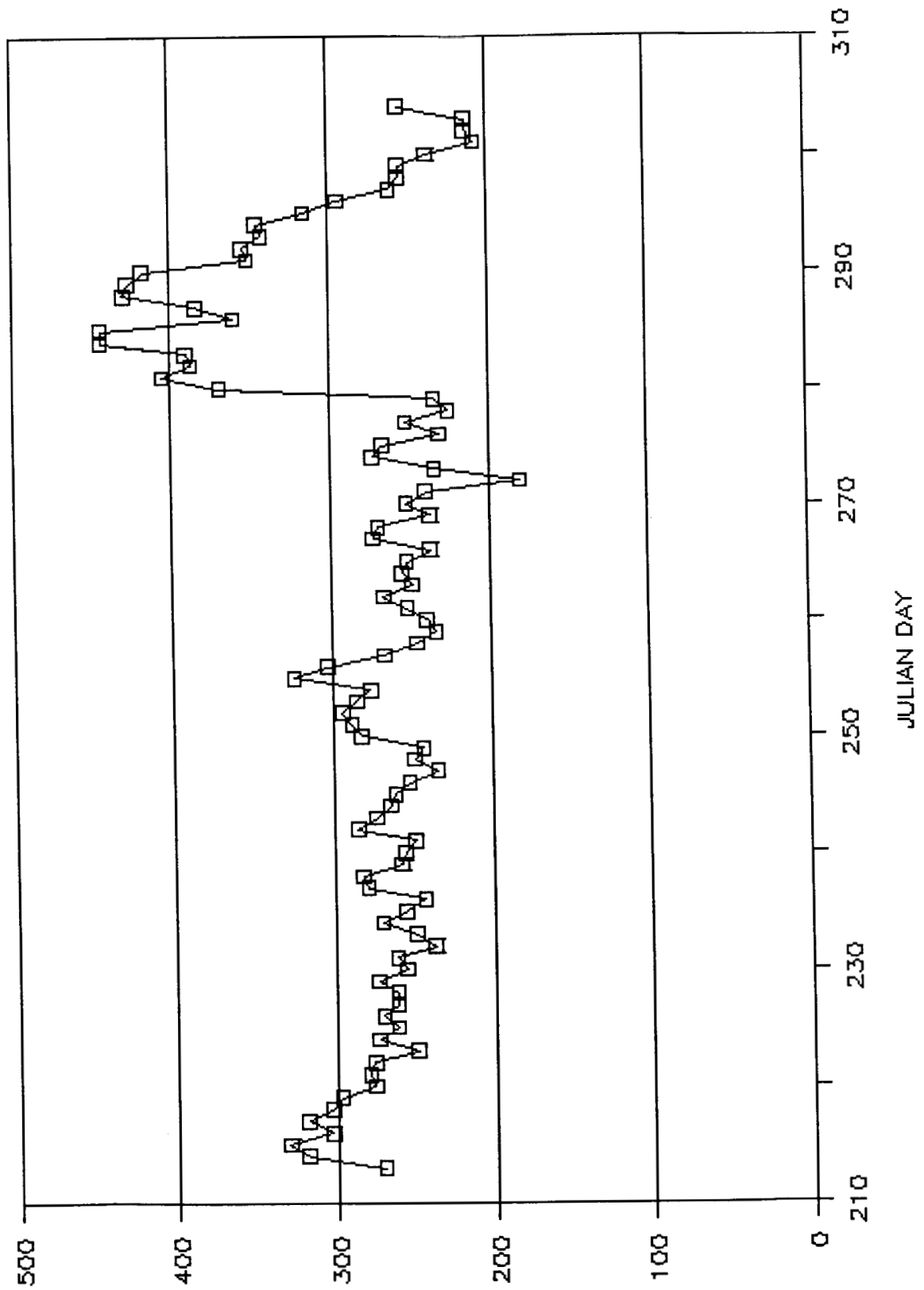

Figure 13d. Daily TOMS Total Ozone Values over Dumont D'Urville (DU).

change in the orientation of the ozone-hole boundary causes the station's readings to decrease once again.

Molodeznaya Station

Molodeznaya is located in coastal Antarctica at 68°S. The total-ozone time series for this station exhibits a decidedly non-stationary character during the period of the experiment (Figure 13e). Prior to mid-September (day 258) the TOMS measurements drop smoothly and almost monotonically from near 250 DU to near 220 DU as the hole forms. However, in late September and throughout October the total ozone abundances fluctuate widely over a range of some 50 to 100 DU, with a periodicity of about five days.

Syowa Station

Syowa is located at 69°S, and is quite close to Molodeznaya. As such, the two time series (Figure 13f) are highly correlated, though the amplitude of the 5-day mode noted at the former station is markedly reduced.

Davis Station

Davis is located on the coast of Antarctica at 69°S, about 30° of longitude away from Molodeznaya. Not surprisingly, the time series for the two locations are quite similar. Substantial differences do occur in the first half of October (Figure 13g), however, when the shape of the ozone hole alters such that Davis, which is about 1° poleward from Molodeznaya, actually lies farther outside the hole.

Halley Bay

The total ozone measurements at Halley Bay at 76°S first become available on August 20. From late August through early October, the total ozone readings drop at an average rate of about 2 to 3 DU per day (Figure 13h), and reach their lowest value of 135 DU on October 6. From the middle to the end of October, the total ozone measurements increase, reaching values of 200 to 300 DU by the end of the month.

McMurdo Station

The McMurdo station is located at 78°S on the McMurdo Sound near the dateline. The TOMS total ozone measurements first become available over McMurdo on August 26 (day 238) and decrease in magnitude throughout September, from about 250 DU down to a minimum value of 141 on October 3 (Figure 13i). During October, several oscillations of the total-column ozone occur, with a period of around 6 days. Referring to the hemispheric charts for the month it is clear that this behavior is caused by the morphology of the ozone hole itself. The maximum values during the period of October 8-12 (days 281-285) are caused by a shift in the center of the ozone hole away from the South Pole, such that the

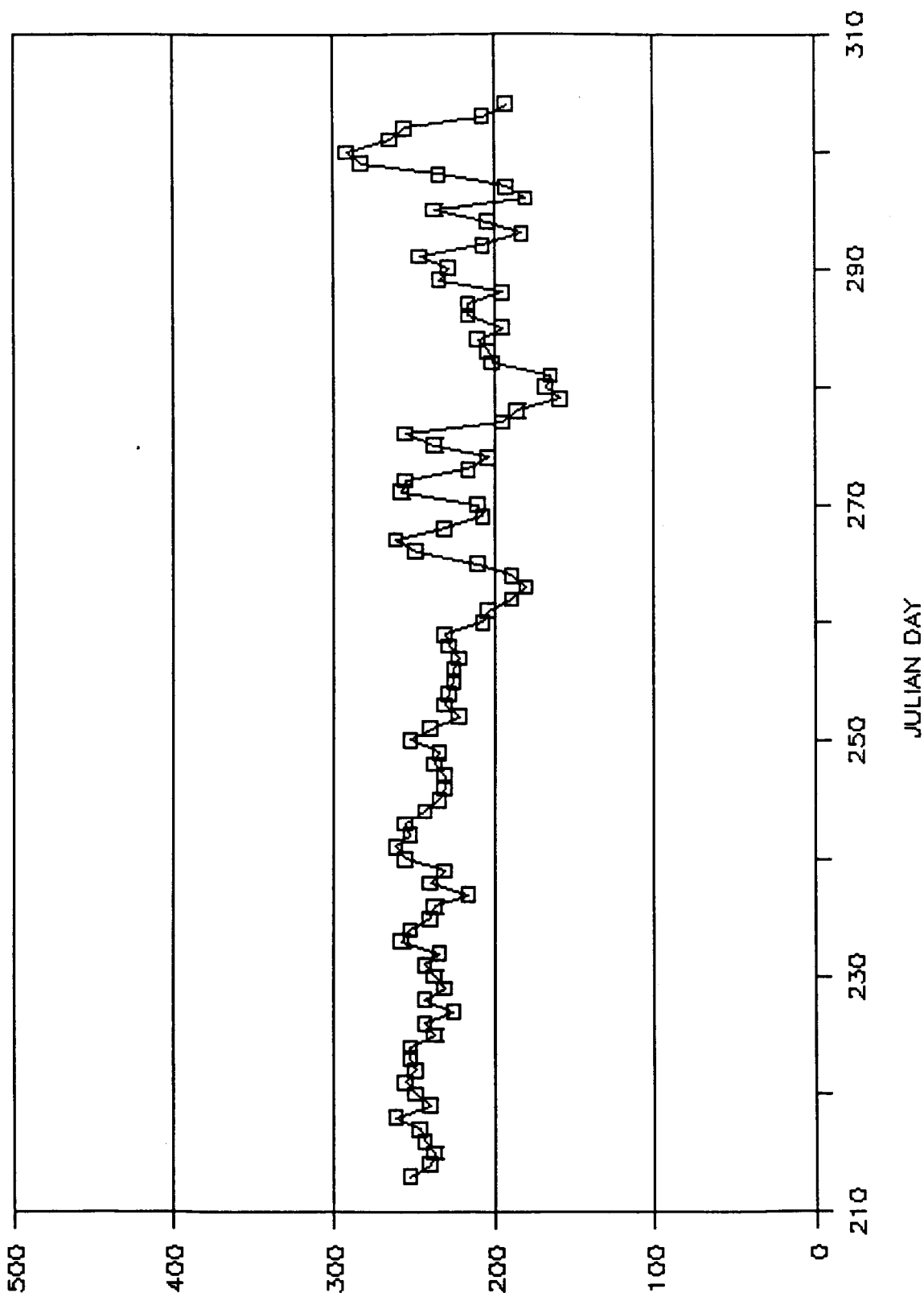

Figure 13e. Daily TOMS Total Ozone Values over Molodeznaya (DU).

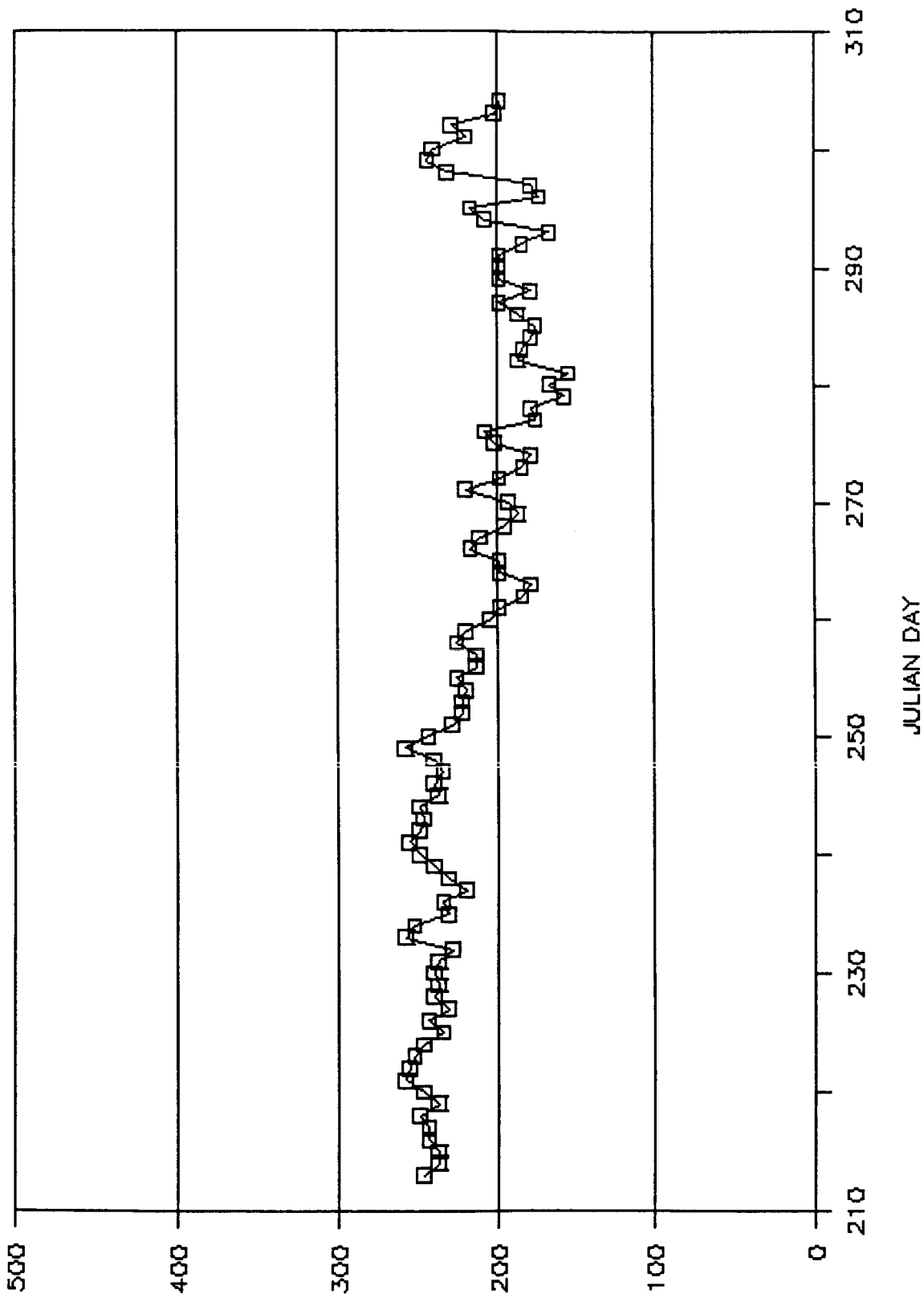

Figure 13f. Daily TOMS Total Ozone Values over Syowa (DU).

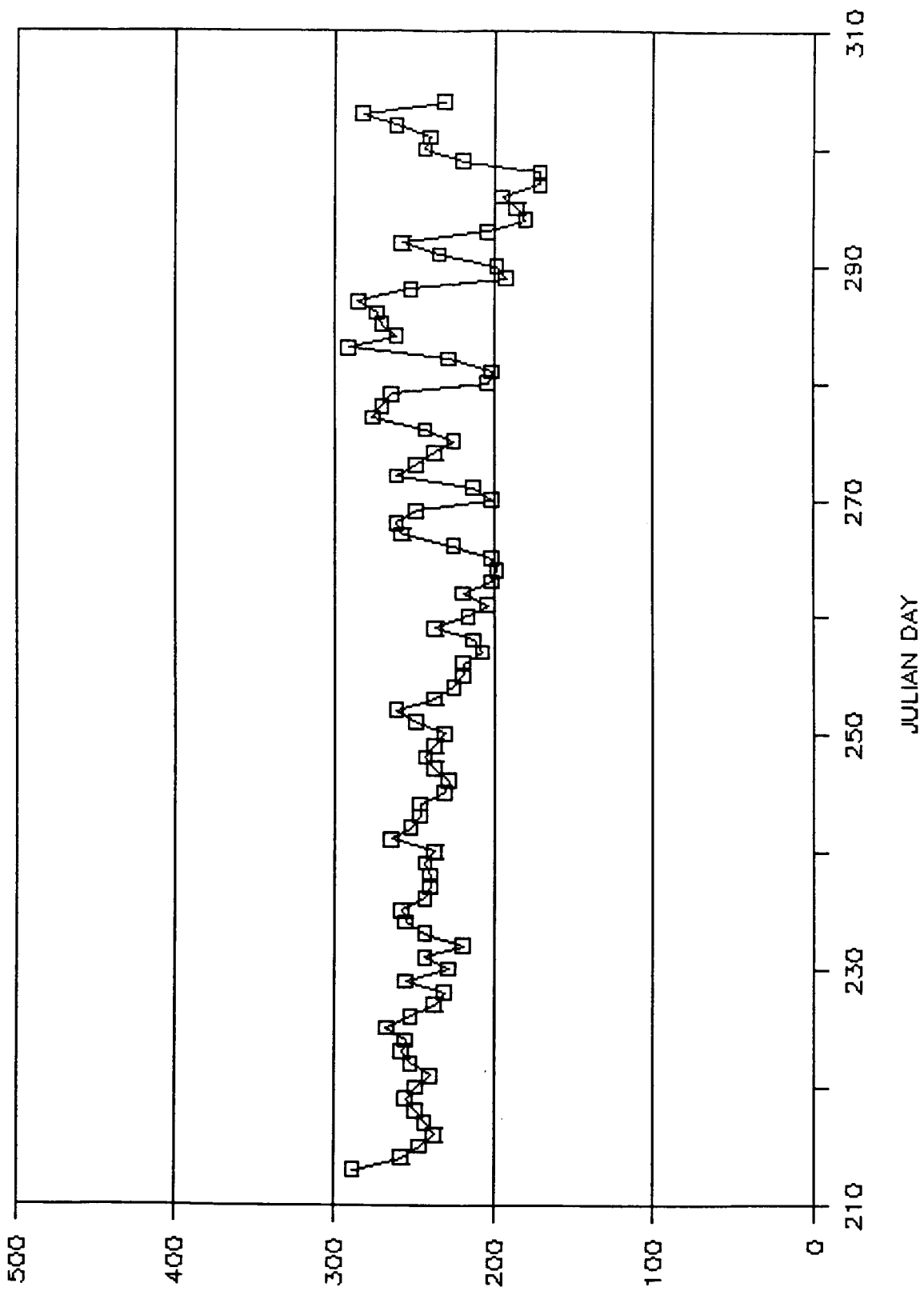

Figure 13g. Daily TOMS Total Ozone Values over Davis (DU).

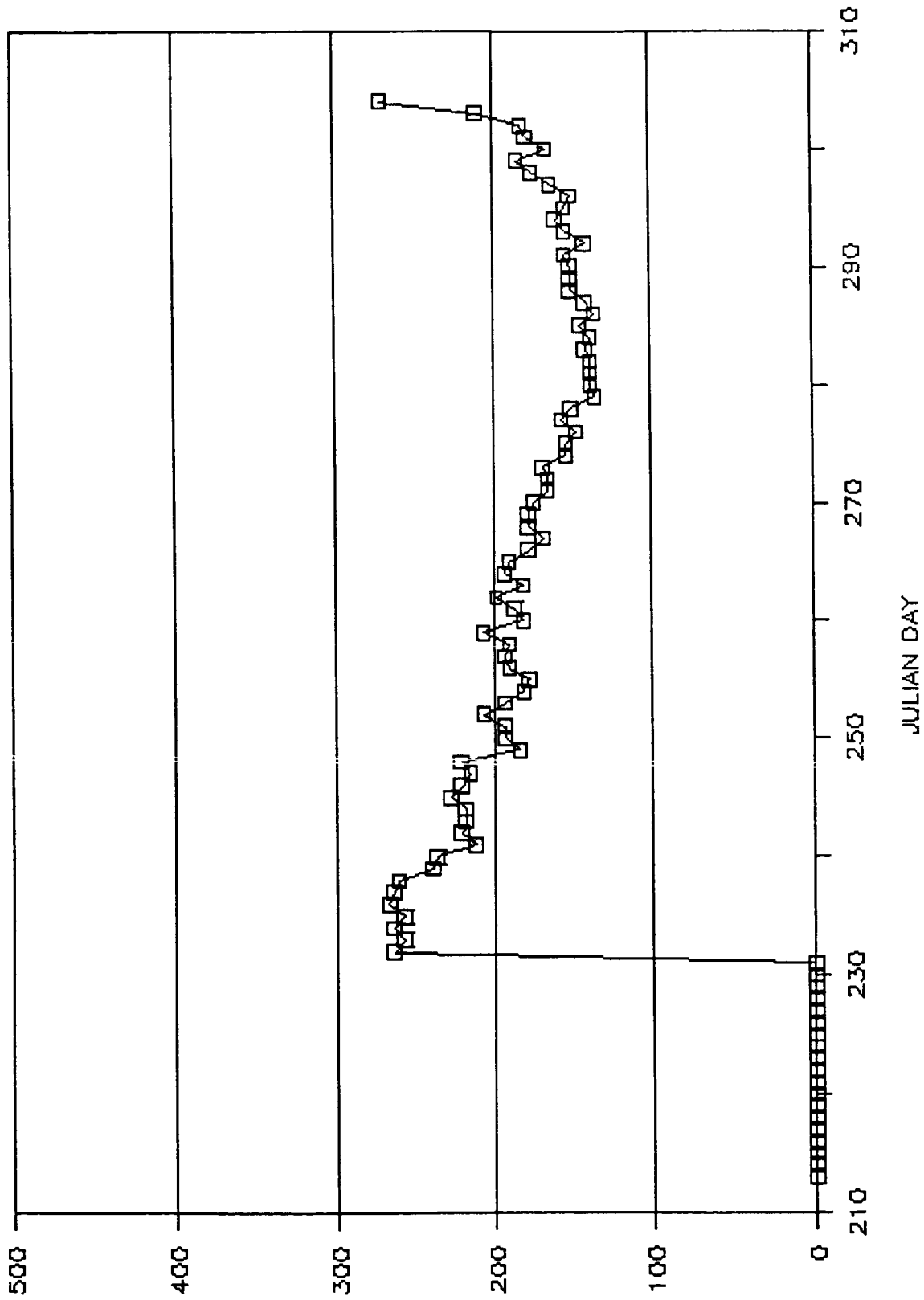

Figure 13h. Daily TOMS Total Ozone Values over Halley Bay (DU).

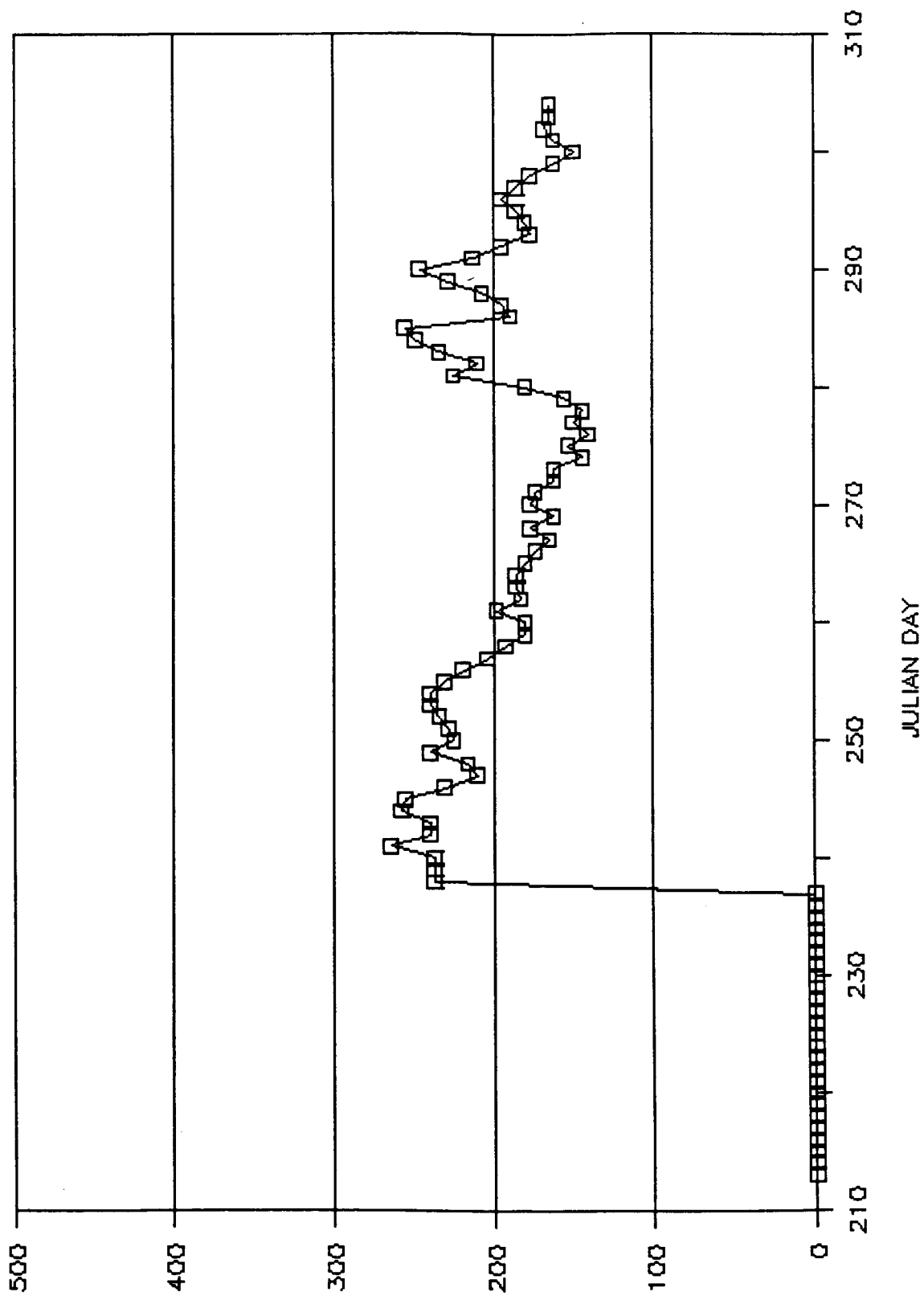

Figure 13i. Daily TOMS Total Ozone Values over McMurdo (DU).

McMurdo Station becomes located within the hole's boundary. The termination of the large total ozone measurements after October 17 (day 290) is clearly caused by the propagation of an extension of the hole over the station.

Vostok Station

The Vostok Station is located deep within continental Antarctica at 78°S. As with McMurdo, total ozone measurements are first obtained on August 26 (Figure 13j) and also exhibit a general downward trend throughout September and into the beginning of October, reaching a minimum value of 144 DU on September 29. Slightly elevated abundances are recorded during most of October, before dropping once again to a new minimum of 135 DU on October 23. Because of the proximity of Vostok to McMurdo, it is clear that the total ozone readings at the two locations are responding in a similar manner to fluctuations in the structure of the ozone hole.

Amundsen-Scott Station

The Amundsen-Scott Station is located at 90°S on the South Pole. At this extreme location, total ozone observations from TOMS do not become available until September 26 (day 269), shortly after the autumnal equinox (Figure 13k). Referring to the TOMS measurement time series, we note that the values remain between 153 DU and 117 DU for the period, without any noticeable trend. The implication is that, for this location, the ozone hole had formed prior to the beginning of the polar day.

6.4 Near-Real-Time Orbital Charts

A set of four examples of orbital TOMS total ozone estimates for a southern hemisphere domain covering portions of South America and Antarctica, and adjacent areas of the Atlantic and Pacific Oceans are presented here (Figures 14a-d). The daily data, over the period August 8 through September 29, 1987, are resolved on the uniform 2° latitude by 1.5° longitude grid for each day, and include those orbits incorporating measurements which were of interest to the experiment for near real time mission-planning purposes.

6.5 Southern Hemispheric Polar Charts

A set of daily TOMS total ozone estimates for the southern hemisphere for four days during, prior to, and after the experiment are presented here (Figure 15a-d). The daily data are resolved on a uniform 2° latitude by 5° longitude grid for each day, and displayed using a south-polar orthographic projection. The advantage of this projection is that emphasis is placed over precisely those high-latitude regions of interest to the Antarctic experiment.

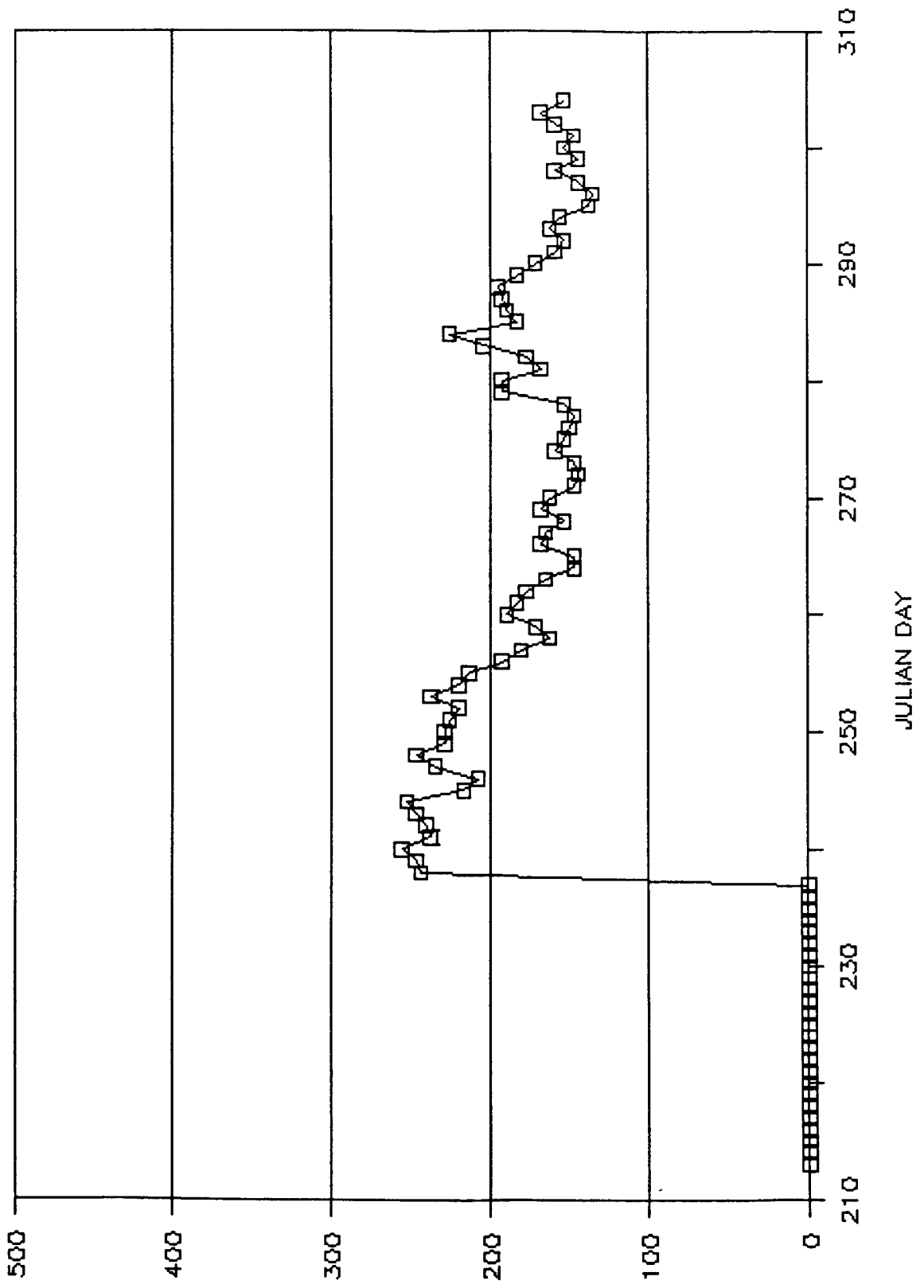

Figure 13j. Daily TOMS Total Ozone Values over Vostok (DU).

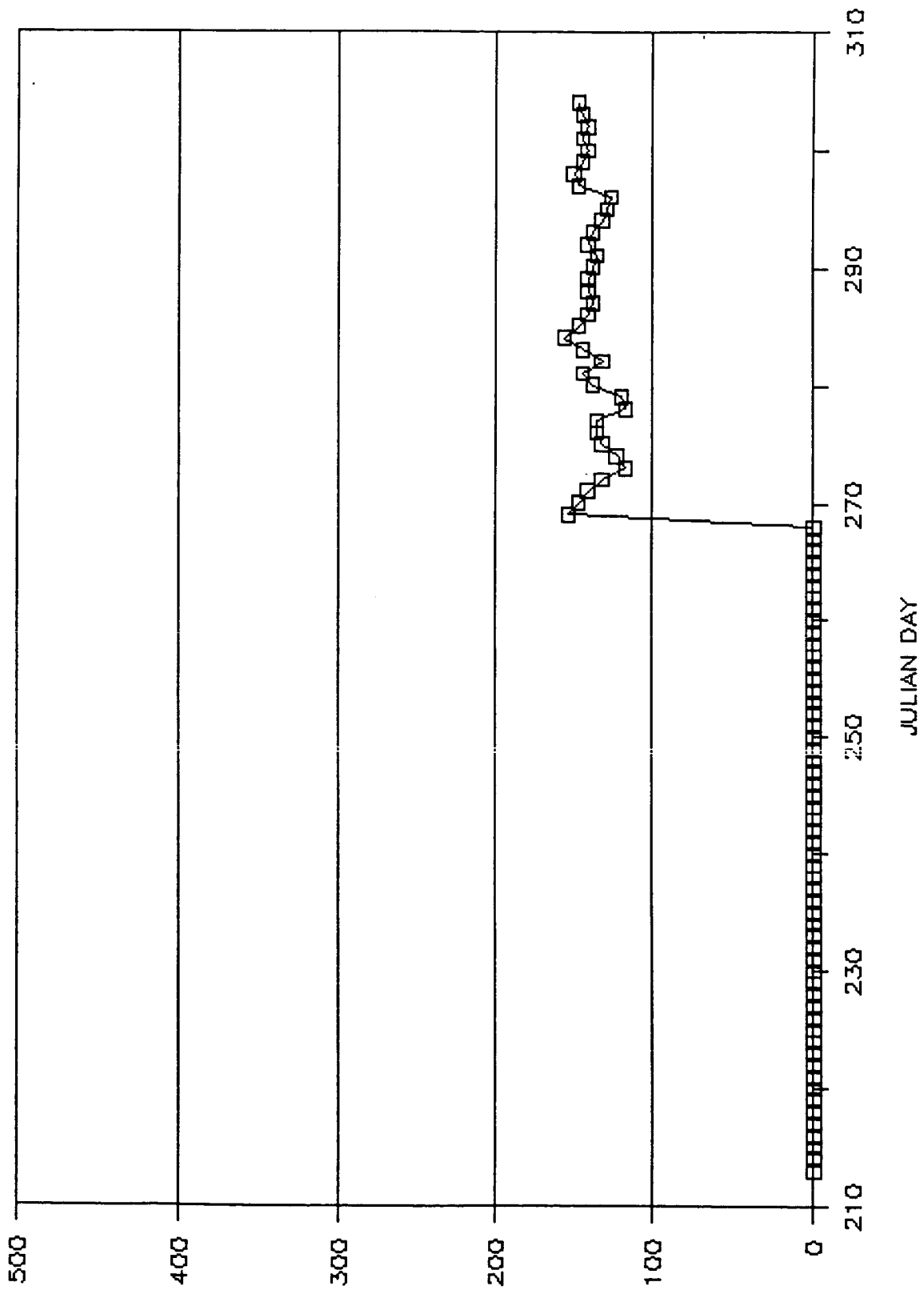
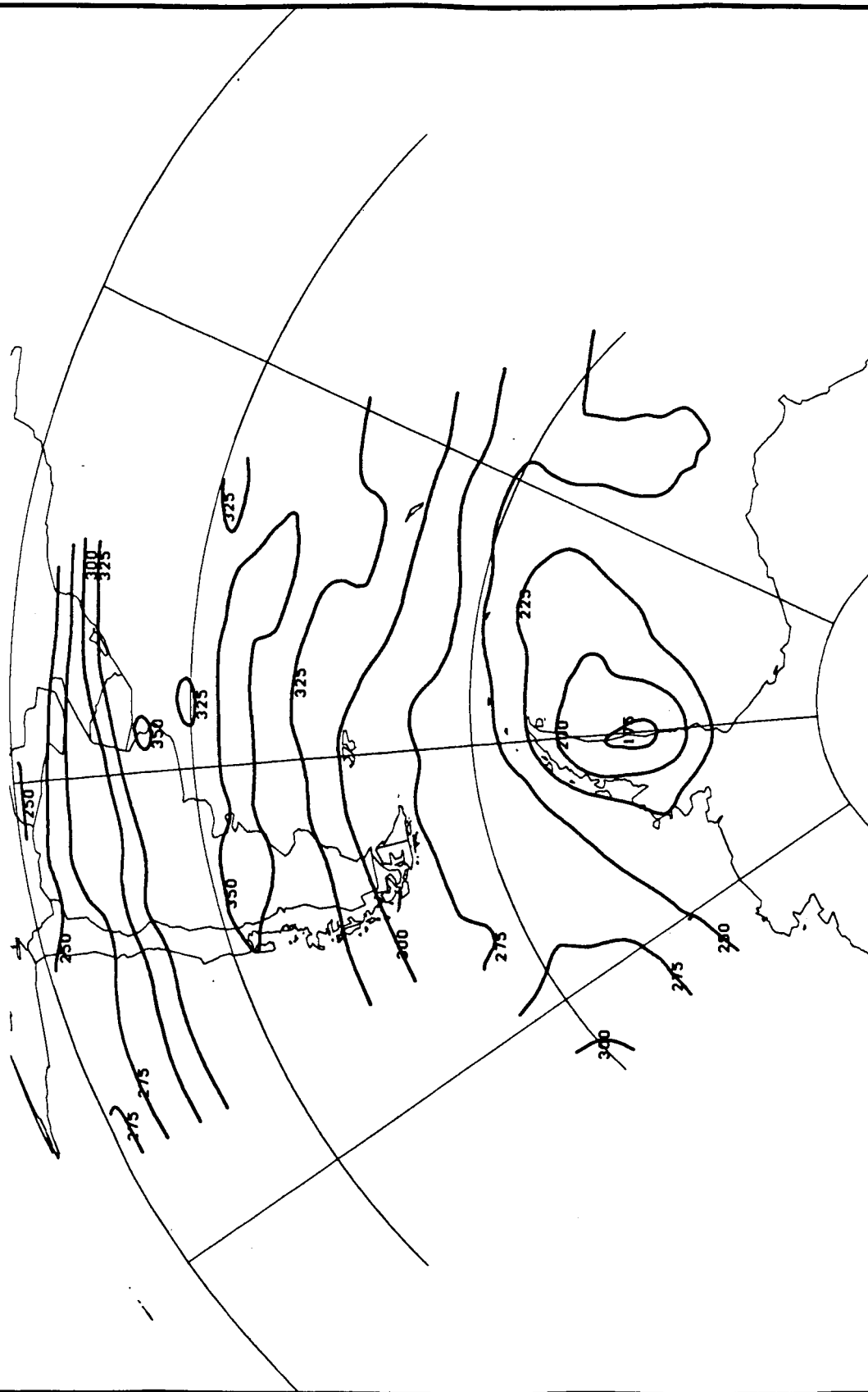

Figure 13k. Daily TOMS Total Ozone Values over Amundsen-Scott (DU).



August 17, 1987

Orbital (44500-1) TOMS Ozone (Dobson Units)

Figure 14a. Orbital TOMS near-real-time total ozone observations for August 17, 1987.

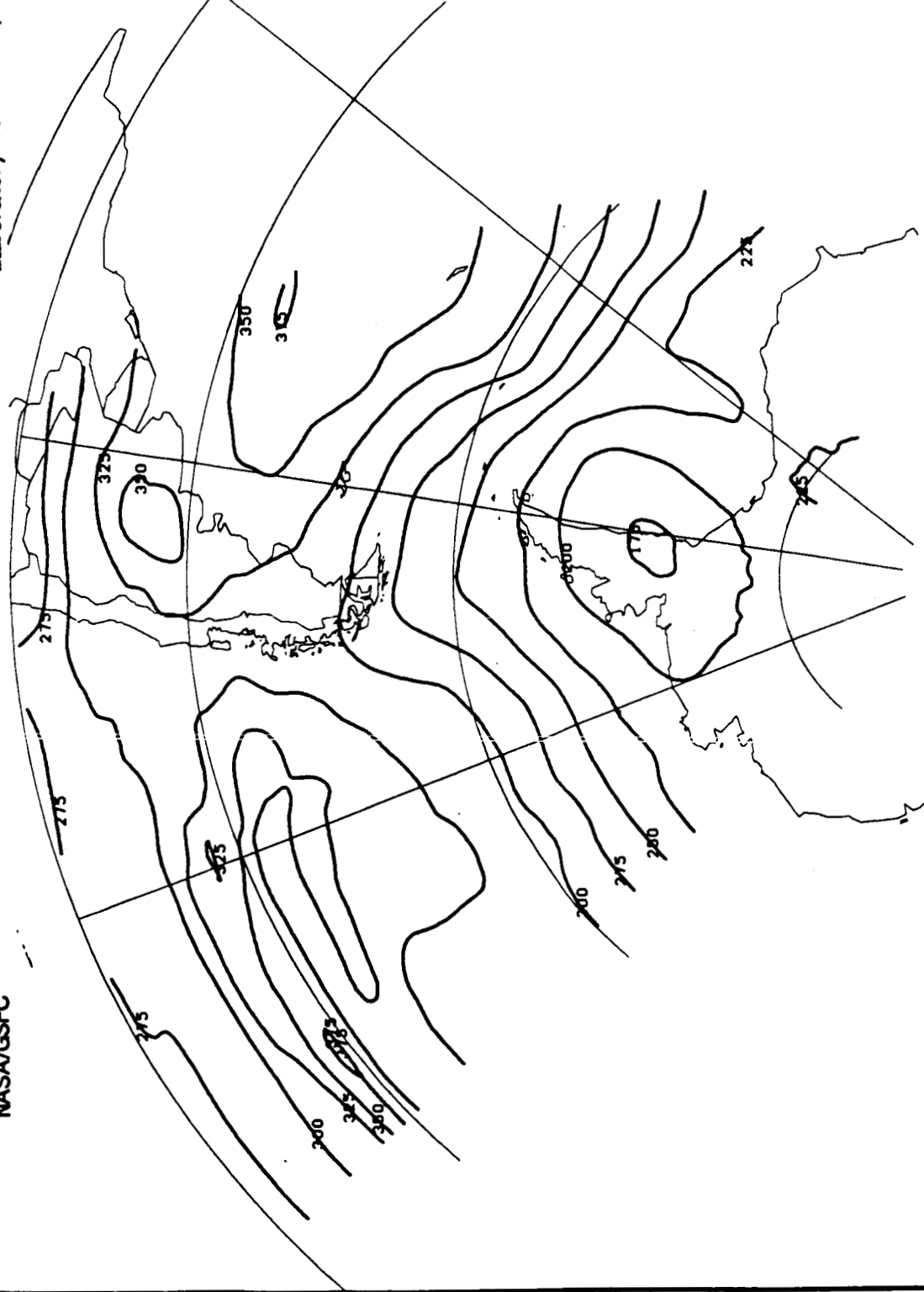

Orbital (44763-4) TMS Ozone (Dobson Units)

September 5, 1987

Figure 14b. Orbital TOMS near-real-time total ozone observations for September 5, 1987.

NASA/GSFC

Laboratory for Atmospheres

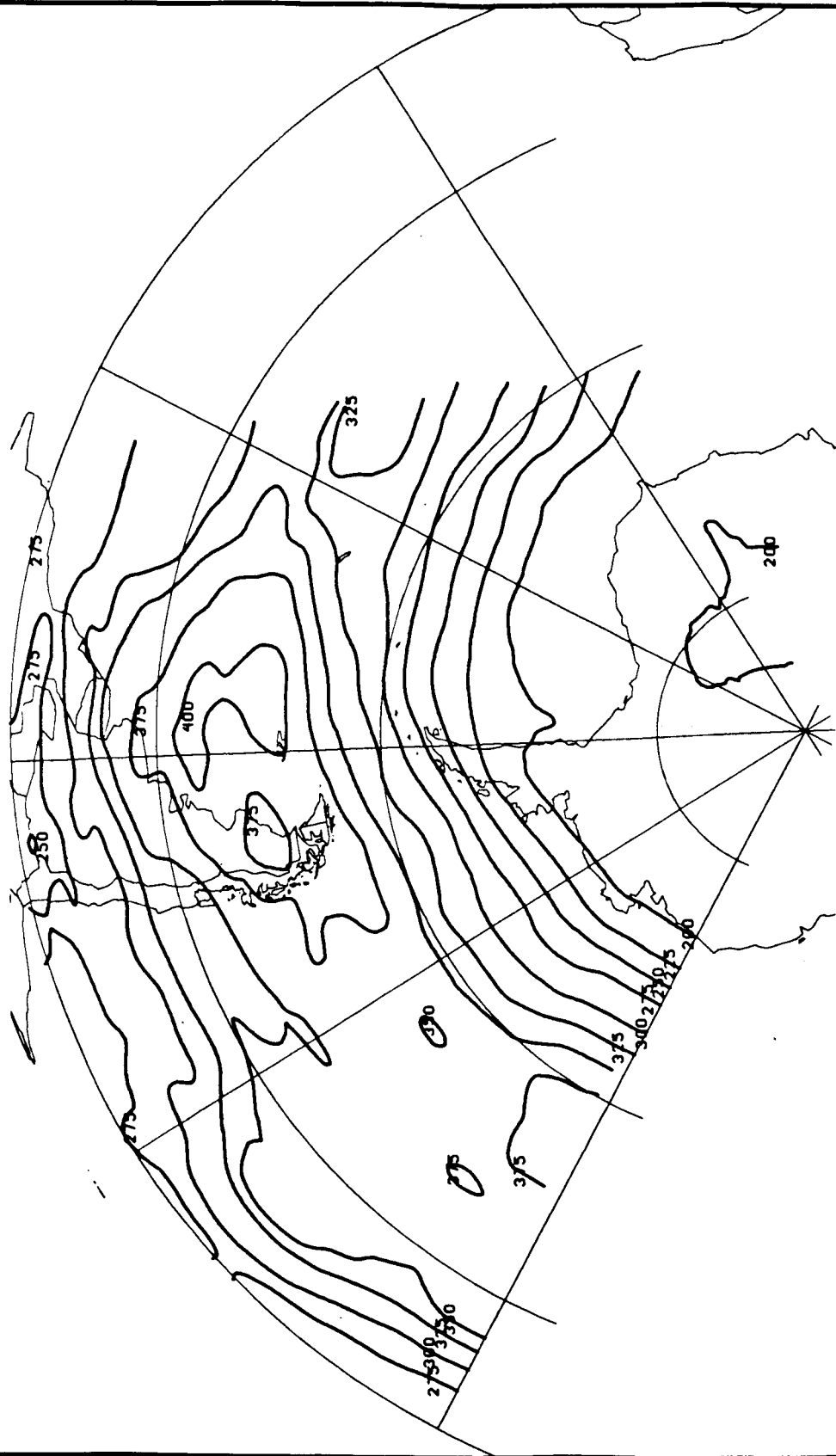

September 18, 1987

Orbital (44942-4) TOMS Ozone (Dobson Units)

Figure 14c. Orbital TOMS near-real-time total ozone observations for September 18, 1987.

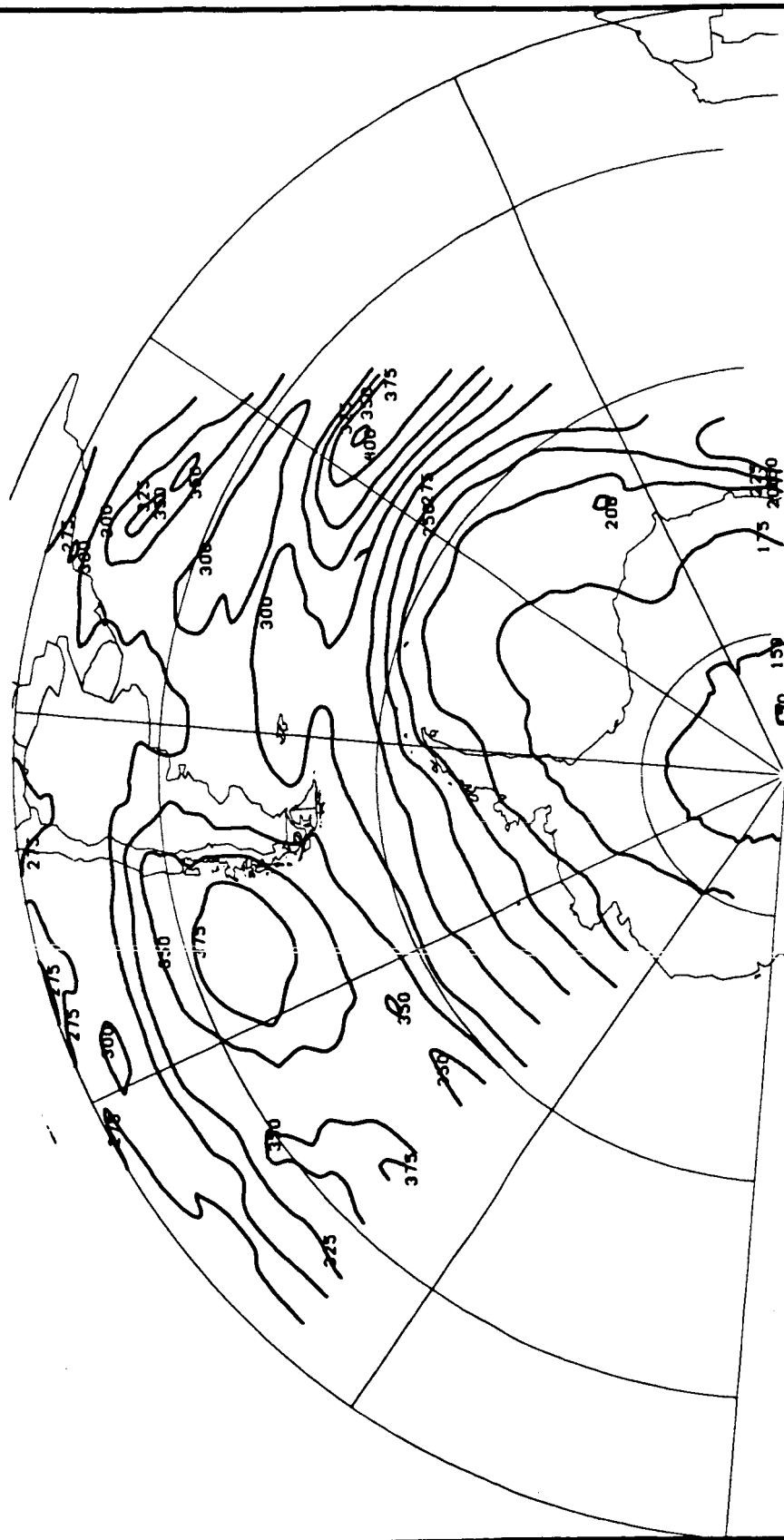

September 28, 1987

Orbital (45080-2) TOMS Ozone (Dobson Units)

Figure 14d. Orbital TOMS near-real-time total ozone observations for September 28, 1987.

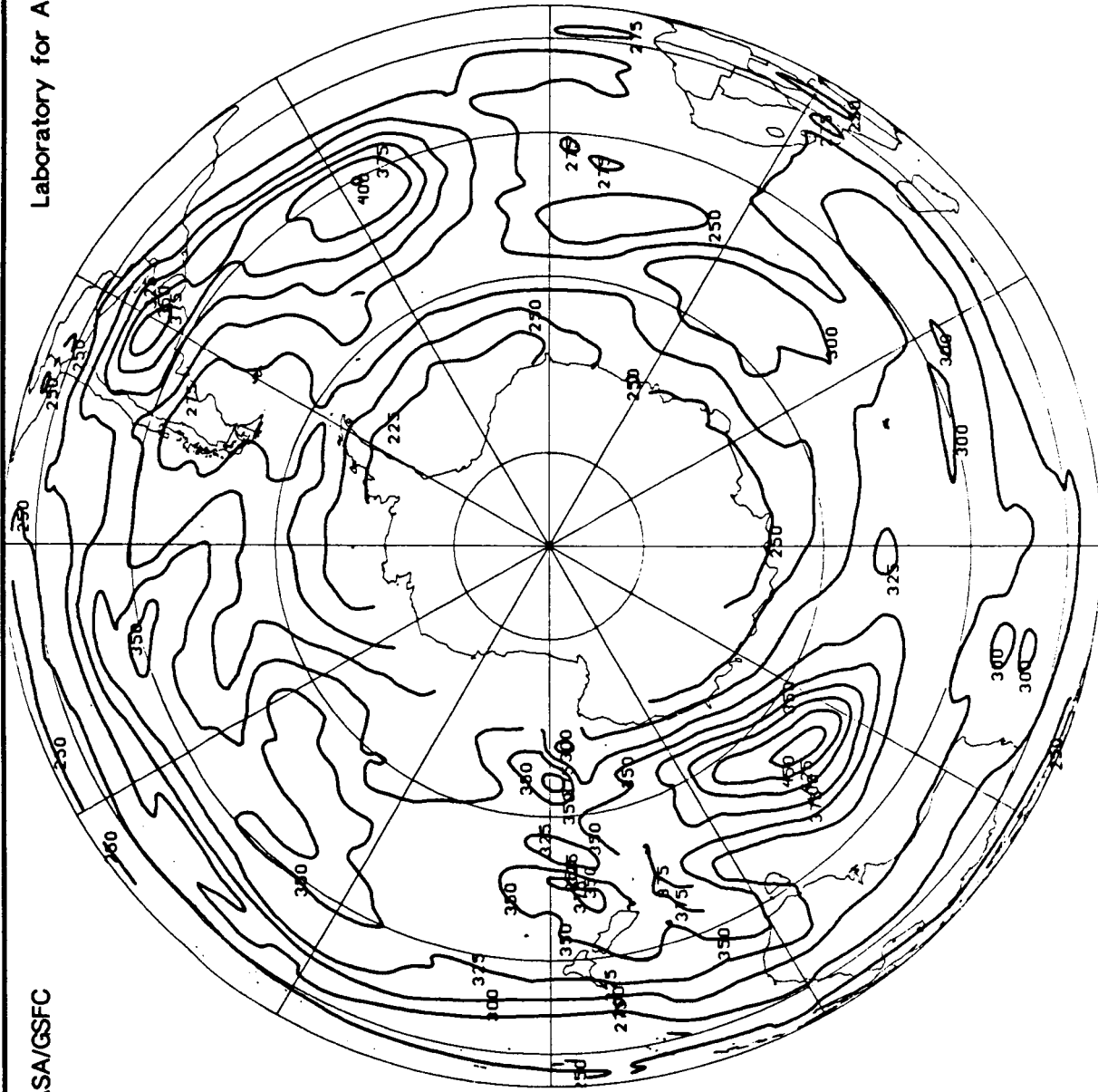

August 5, 1987

Gridded TOMS Ozone (Dobson Units)

Figure 15a. TOMS near-real-time total ozone measurements over the southern hemisphere on August 5, 1987.

ORIGINAL PAGE IS
OF POOR QUALITY

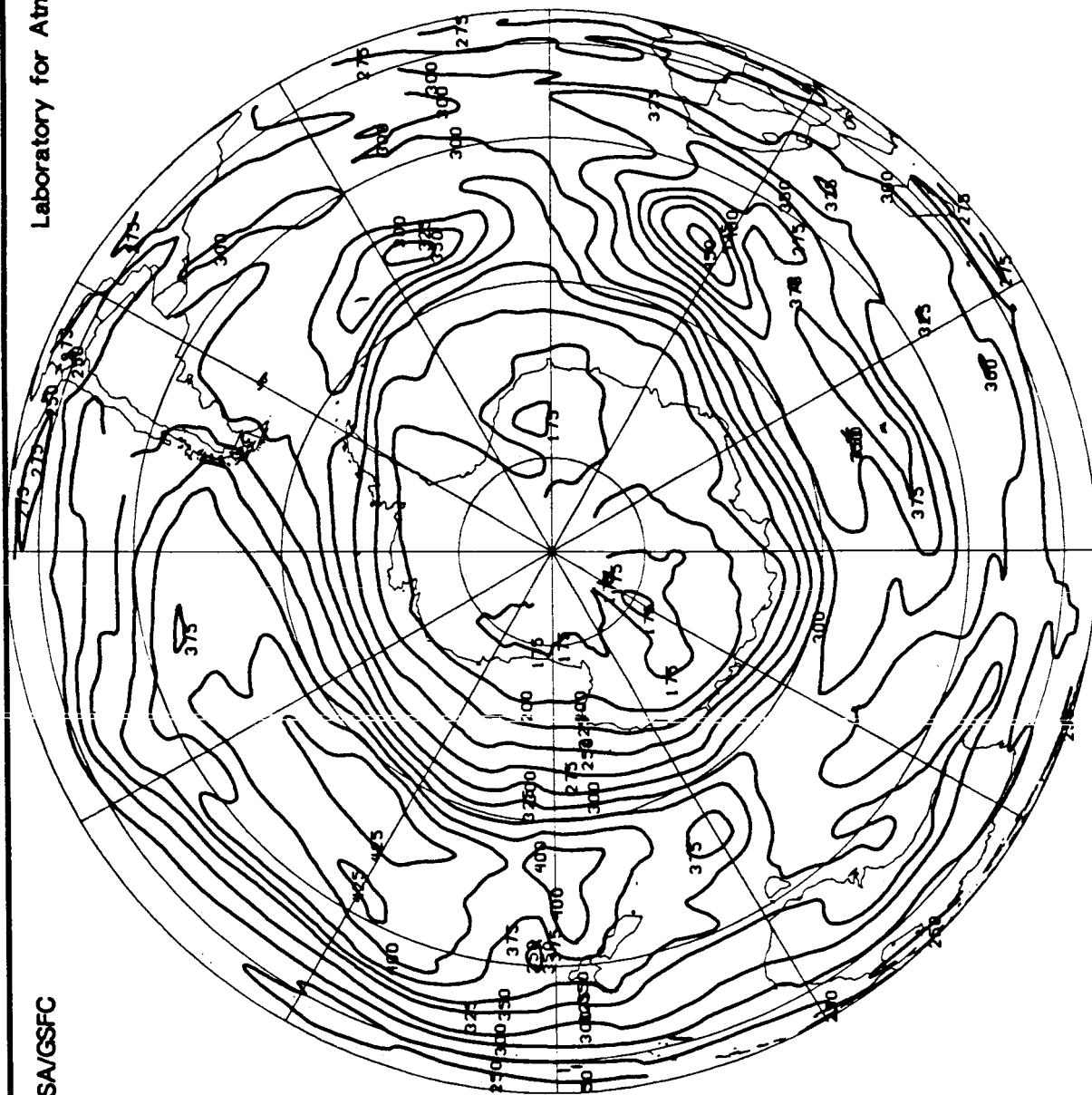

Gridded TOMS Ozone (Dobson Units)

September 16, 1987

Figure 15b. TOMS near-real-time total ozone measurements over the southern hemisphere on September 16, 1987.

NASA/GSFC

Laboratory for Atmospheres

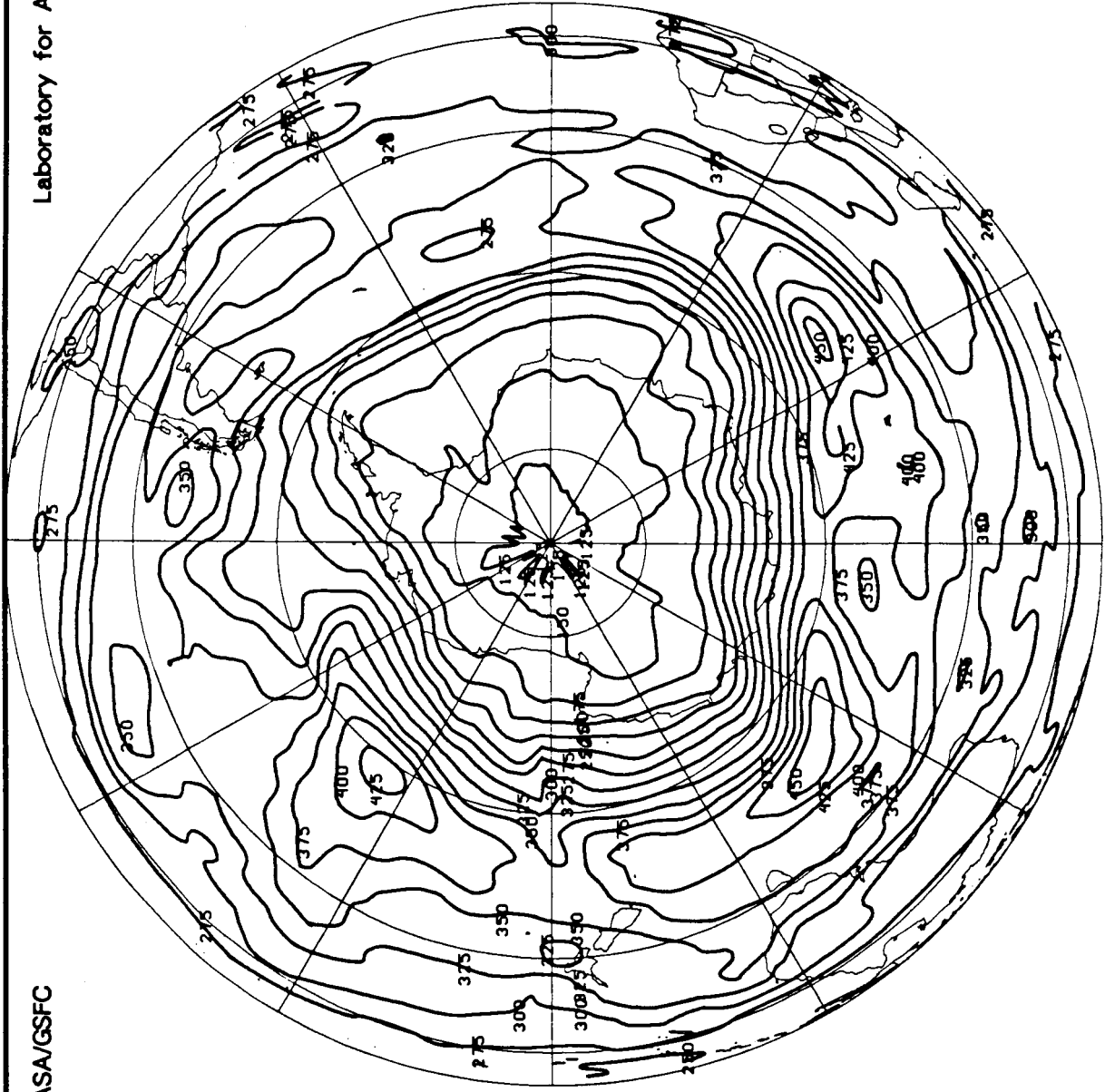

October 5, 1987

Gridded TOMS Ozone (Dobson Units)

ORIGINAL PAGE IS
OF POOR QUALITY

Figure 15c. TOMS near-real-time total ozone measurements over the southern hemisphere on October 5, 1987.

NASA/GSFC

Laboratory for Atmospheres

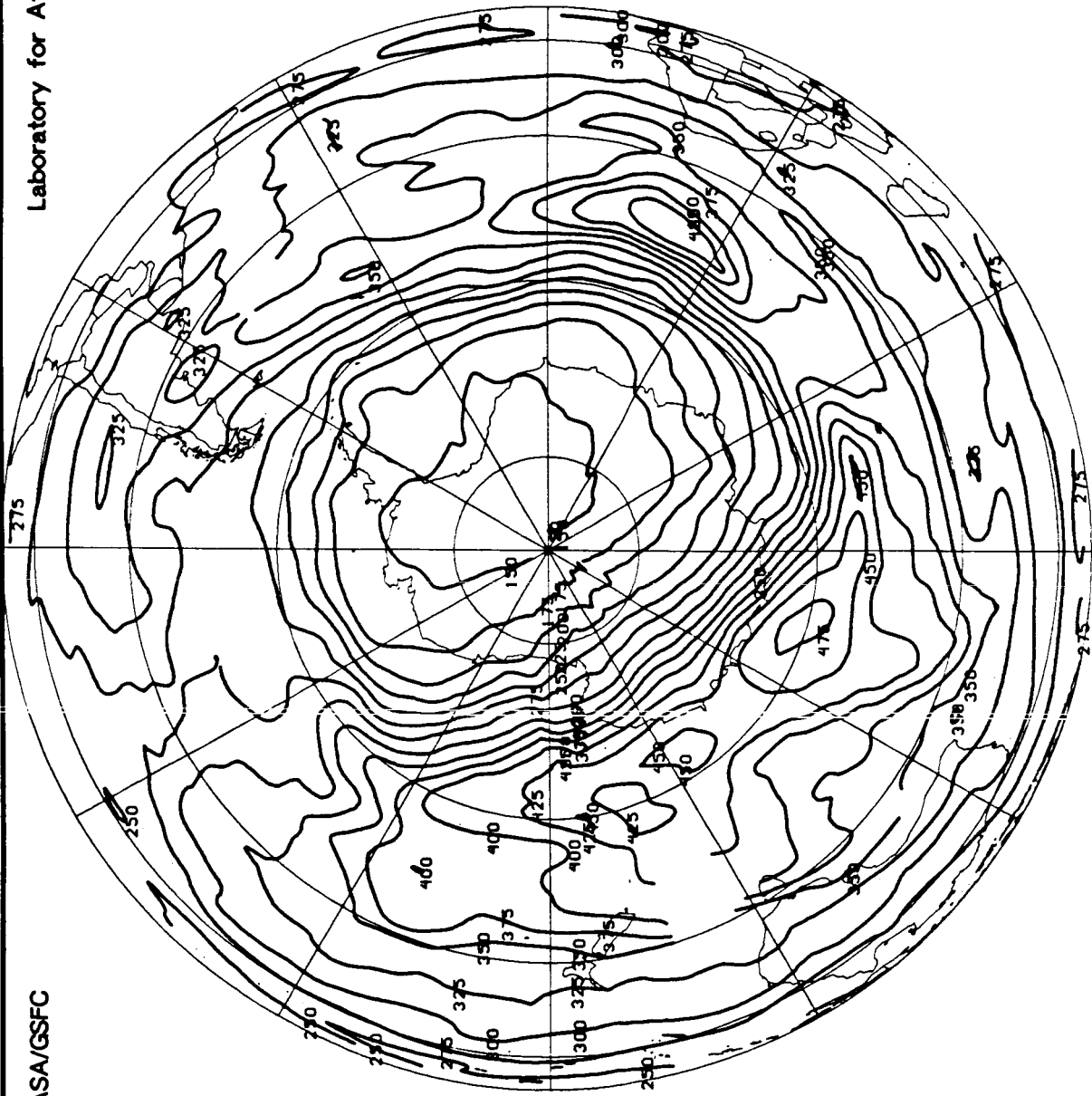

October 11, 1987

Gridded TOMS Ozone (Dobson Units)

Figure 15d. TOMS near-real-time total ozone measurements over the southern hemisphere on October 11, 1987.

7. PRELIMINARY ANALYSIS OF THE 1987 OZONE HOLE BASED ON TOMS DATA

In this section, we will consider the adiabatic aspects of the Antarctic ozone hole before, during, and after its appearance. Diabatic effects, such as the roles of chemistry and radiation, are left to other investigators.

Before the hole developed, there were numerous relatively small-scale "mini-holes" which briefly made their appearance near the boundary of the polar night. Then, about August 16, a rather pronounced feature appeared just east of the Antarctic peninsula. The feature was, in general, an ozone minimum about the size of the Weddell Sea, but had in it an interesting wave structure which will also be described. These preconditions are discussed in Section 7.1

In Section 7.2, the initiation of the hole will be described. This formative process was characterized by a pronounced ozone minimum which seemed to advect westward around the terminator at a speed of approximately 30 m/s. Then, suddenly, it intensified east of the peninsula, continued its eastward migration and abruptly became stationary over a western quadrant of Antarctica.

During the hole's maturity, the strength of thermal advectations increased dramatically at most stratospheric levels. The location of these areas of warm and cold advection will be theoretically related to regions of adiabatic vertical motion. In many instances, there was evidence of standing-wave features in the behavior of the hole. Also, there was an unexpected mix of different circulation types within the hole itself. All of these features will be discussed in detail in Section 7.3.

Finally, the dissolution of the Antarctic ozone hole will be described in Section 7.4 in terms of obvious circulation changes which occurred during this latter period of the hole's existence. Efforts to ascertain the degree to which mid-latitude ozone-rich air was brought into the vicinity of the hole will be made.

7.1 Preconditions to the Formation of the Hole

Mini-Holes

Figure 16 is perhaps the best example of the total ozone distribution over the southern hemisphere before the major ozone hole formed. There appear to be numerous mini-holes surrounding the polar night terminator. Each minimum is characteristically somewhere between the terminator and the northern boundaries of the Antarctic continent. These mini-holes are short-lived and change little in areal extent.

ORIGINAL PAGE IS
OF POOR QUALITY

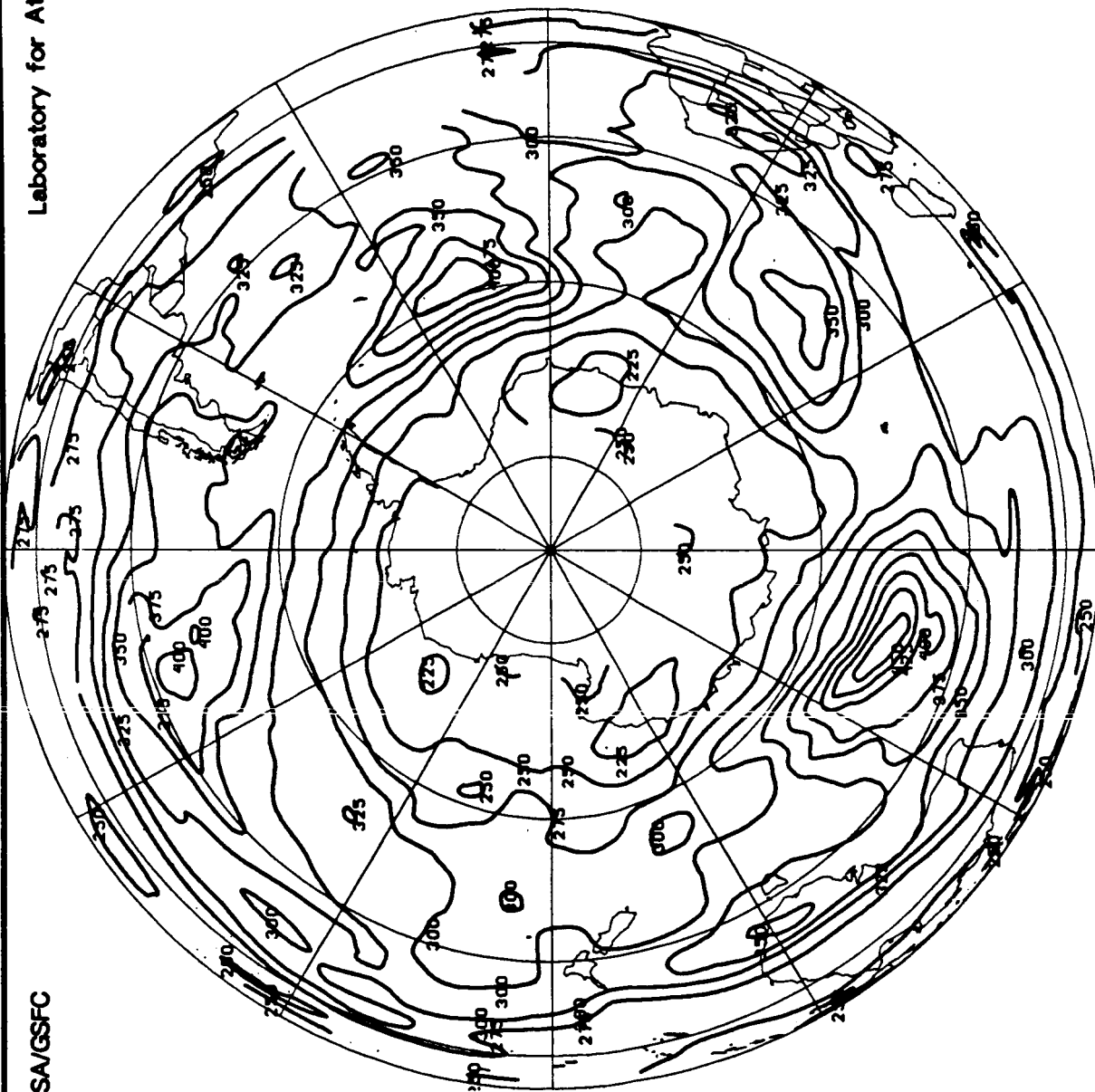

Gridded TOMS Ozone (Dobson Units)

August 24, 1987

Figure 16. TOMS ozone distribution for the southern hemisphere on August 24, 1987.

Circulation and Temperature

In mid-latitudes, there are characteristic centers of high total ozone amount. These features, too, vary in strength with time and slowly migrate westward around the continent.

Figure 17 gives an ECMWF wind and temperature analysis, and the TOMS total ozone for August 24, 1987. The ECMWF analysis level is 70 mb, and the winds are given in knots along with Celsius temperatures (minus signs are omitted). The thin lines on this analysis are isotherms every two degrees Celsius, and the thick arrows are streamlines. This chart is quite characteristic of similar analyses for the period before the development of the ozone hole itself.

The temperature analysis shows a great deal of symmetry around the south pole with the coldest air (-89°C) being almost coincident with the south pole. Reference to Figure 16 indicates that the coldest air is also usually associated with the polar-night region and the total-ozone minima.

The winds at 70 mb (Figure 17) show the flow generally to be zonal except for slight meridional flow associated with several short-wave troughs. A jetstream is present at mid-latitudes, and jet cores can be noted between Antarctica and (1) Australia, (2) South America, and (3) Africa. Of course, temperature advections will potentially be greatest in these areas because of the high wind speeds.

However, we can look at the thermal advection directly by referring to Figure 18. This figure shows the temperature advection at 70 mb for August 24, 1987 as determined by geostrophic analysis of NOAA upper air data (70 mb heights). There is rather good agreement between the two advection patterns.

The implication here is that the total ozone maximum patterns (Figure 17) seem to be closely related to regions of rather strong cold temperature advections (Figure 18, e.g., southeast of Australia). The total ozone minima, on the other hand, relate to regions of strong warm temperature advection.

7.2 Initiation of the Hole

There are three other very important features that were discovered to occur near the beginning of the 1987 Airborne Antarctic Ozone Experiment. First, between August 15-17, 1987, a small but pronounced minimum appeared just east of the Antarctic peninsula. For the three days this minimum remained quasi-stationary but exhibited some unusual wave features that merit special attention. Second, during the period August 26-29, 1987, dramatic changes occurred in the vertical ozone profiles made at both Palmer station and Halley Bay. The ozone profile initially had a peak near 70 mb. Suddenly, within a day or two, the profile showed an erosion of ozone below the peak. Even more spectacular was the

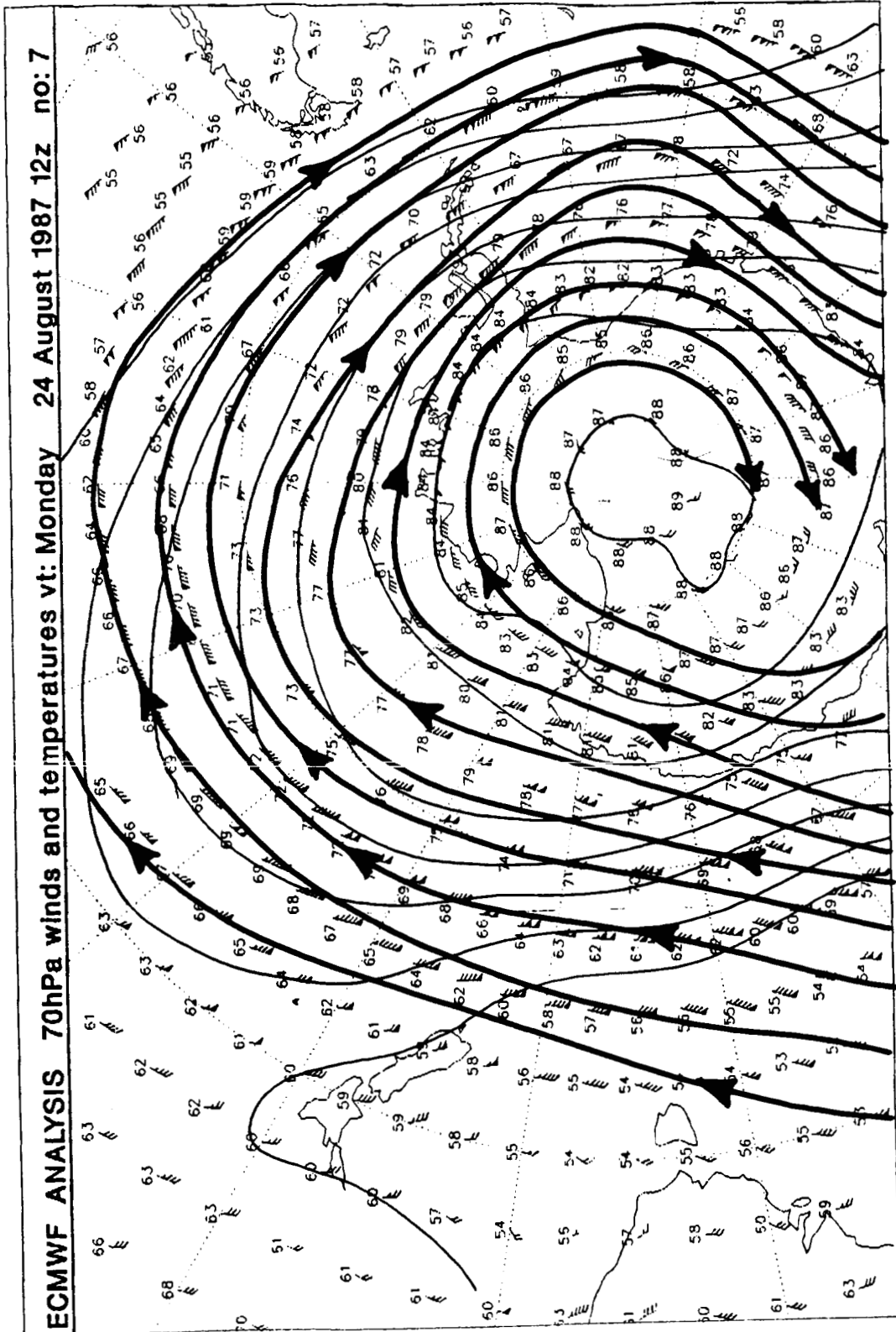

Figure 17. ECMWF 70 mb analysis for August 24, 1987. Temperatures are in °C with minus signs omitted; arrows indicate direction of the wind.

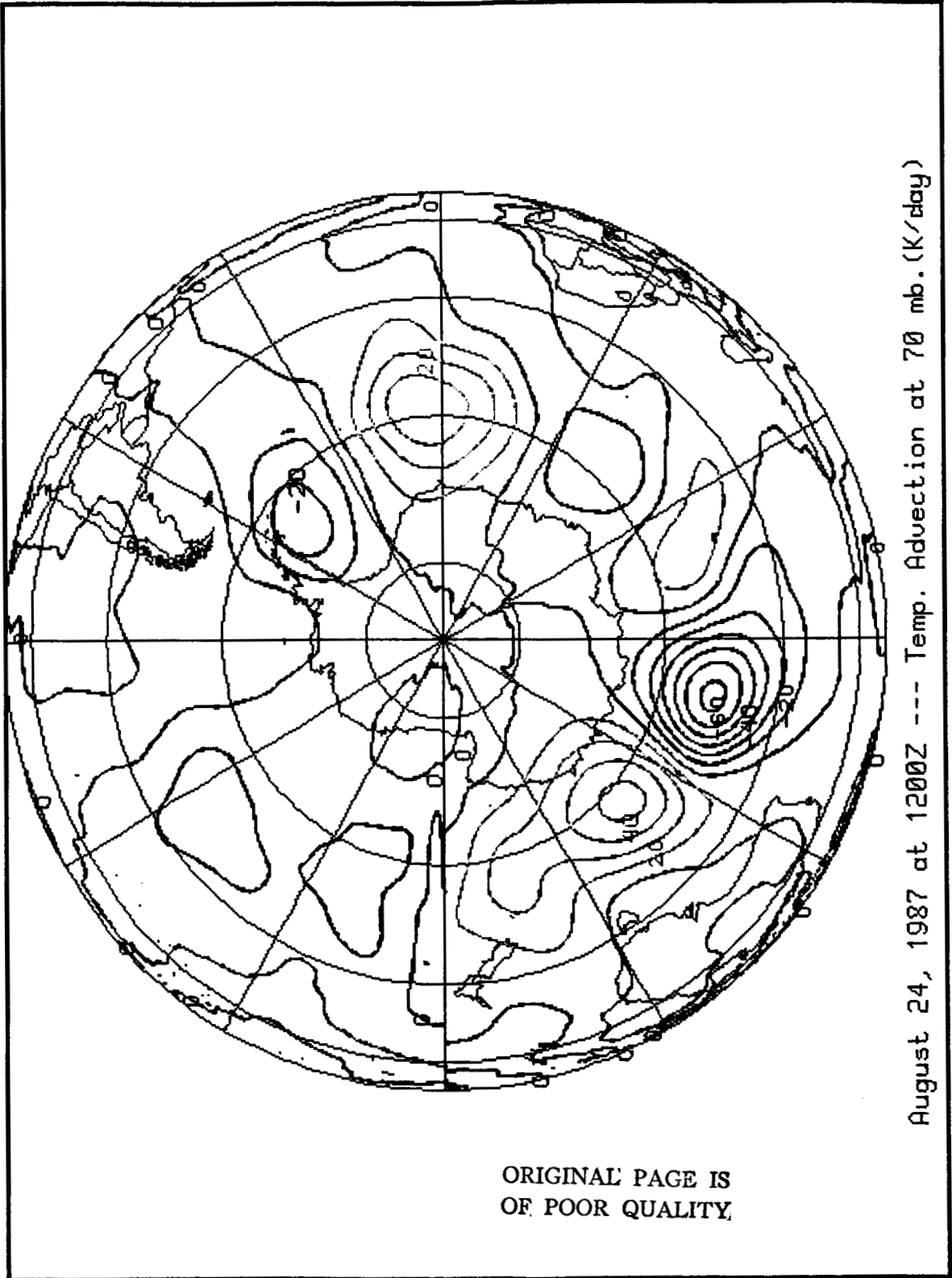

Figure 18. 70 mb temperature advection for August 24, 1987.

sudden disappearance of the peak itself during the next two days. Third, another total ozone minimum developed east of the peninsula on September 5, 1987. This minimum is unique because it was to develop into part of the 1987 Antarctic ozone hole. This hole migrated westward several hundred kilometers during the 6th and 7th, and then surprisingly became stationary for the next several days. All of the above features will be described in detail using ozone profiles and the relevant charts.

Mountain Waves

Between August 15-17, 1987, an interesting wave pattern was seen to develop in a new total ozone minimum just east of the Antarctic peninsula. Figure 19 shows how this wave pattern appeared on the 16th in the operational two orbit average sent to Punta Arenas. At first there was some suspicion that this wave pattern may be simply an artifact of the TOMS data processing procedure. To determine whether or not this was the case, individual orbital data were examined. These are shown in Figure 20a and 20b. Figure 20a displays the TOMS data for Nimbus-7 orbit number 44486 which shows a distinct minimum just east of the peninsula's base. An area of relatively low ozone extends eastward from this minimum, decreasing rather uniformly as it does so. Figure 20b gives orbit number 44487. This imagery clearly shows three successive areas of decreased ozone amount. The largest areas of minimal values is at the base of the peninsula, the next just east of the base and then the third area to the east simply displays an erosion of the uniform pattern seen in the previous orbit. It is concluded that the TOMS instrument did indeed detect a wave-like pattern with a wavelength on the order of one or two degrees of latitude. Whether or not this wave pattern was established as a lee wave east of the peninsula's mountain range remains an area of speculation, but a wave pattern of some type is clearly present on August 16, 1987. A figure is not given, but a similar feature was observed on August 17 as well. It is also noteworthy that the same type of wave pattern was detected in the same area east of the peninsula in 1986.

Standing Waves

One characteristic which persists throughout the evolution of the Antarctic ozone hole involves the variations in translation rates of the total ozone extrema. A maximum or minimum will form and propagate at varying speeds up to 35 m/s and then suddenly stop its eastward progression. The reason for this variation in the speed of the translation of the centers is left for a more complete discussion in the next section, when the roles of ozone advection and vertical motion are treated.

A good example of the sudden deceleration of a low total-ozone region is given in Figure 21a-c, which give a history of the TOMS total ozone over the southern hemisphere for the period of September 5-15. An ozone minimum, different from the one discussed previously, again appeared east of the Antarctic peninsula

DAY:228

AUG 16, 87

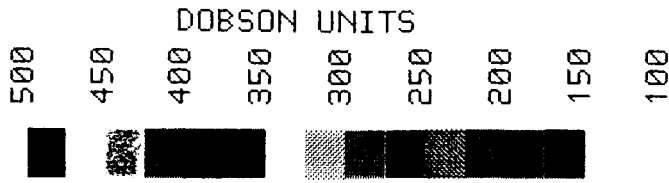
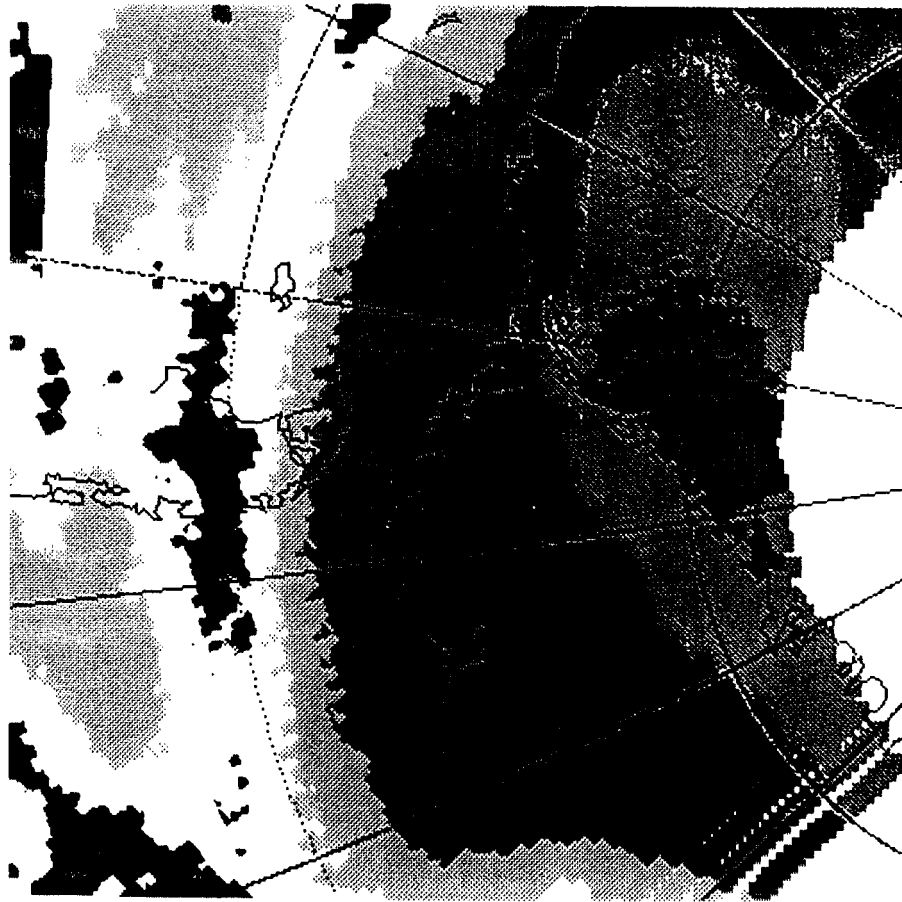

NIMBUS-7: TOMS
TOTAL OZONE
NASA/GSFC

ORBITS 44485-44488

Figure 19. Orbital TOMS ozone contours for August 16, 1987 (orbits 44485-44488).

DAY:228

AUG 16, 87

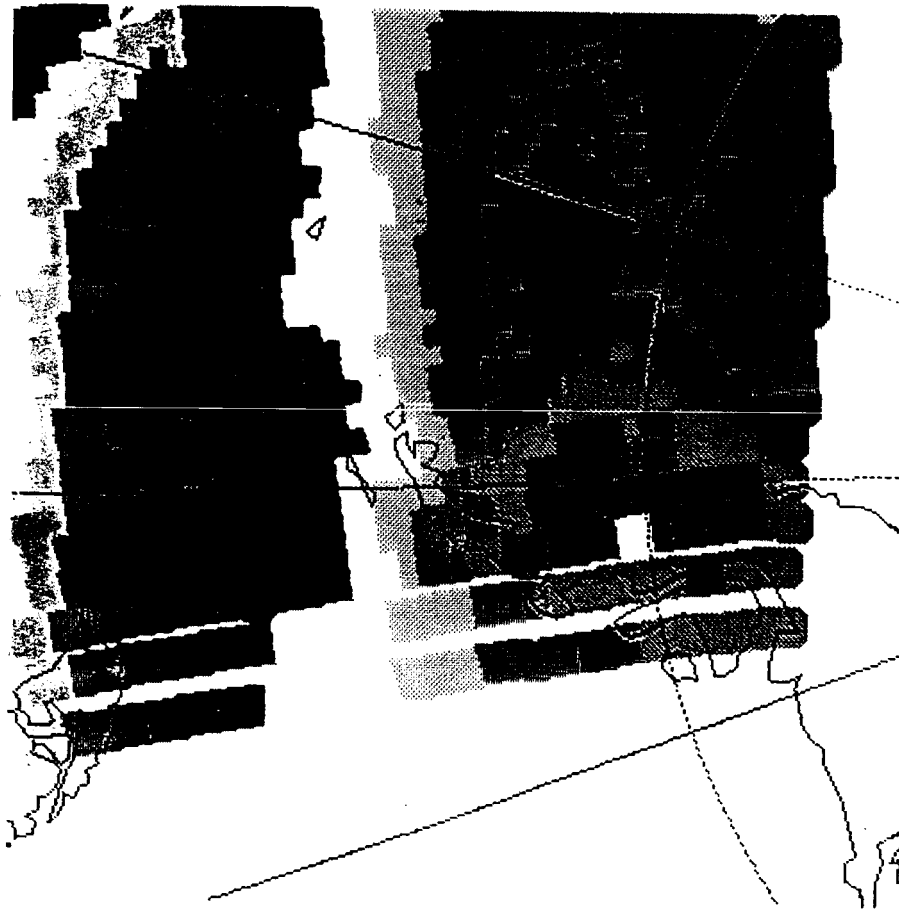

ORIGINAL PAGE IS
OF POOR QUALITY

DOBSON UNITS

350
300
250
200
150

NIMBUS-7: TOMS
TOTAL OZONE
NASA/GSFC

ORBIT 44486

Figure 20a. Orbital TOMS ozone contours for August 16, 1987 (orbit 44486).

DAY:228

AUG 16, 87



350
300
250
200
150
DOBSON UNITS

NIMBUS-7:TOMS
TOTAL OZONE
NASA/GSFC

ORBIT 44487

Figure 20b. Orbital TOMS ozone contours for August 16, 1987 (orbit 44487).

NASA/GSFC

Laboratory for Atmospheres

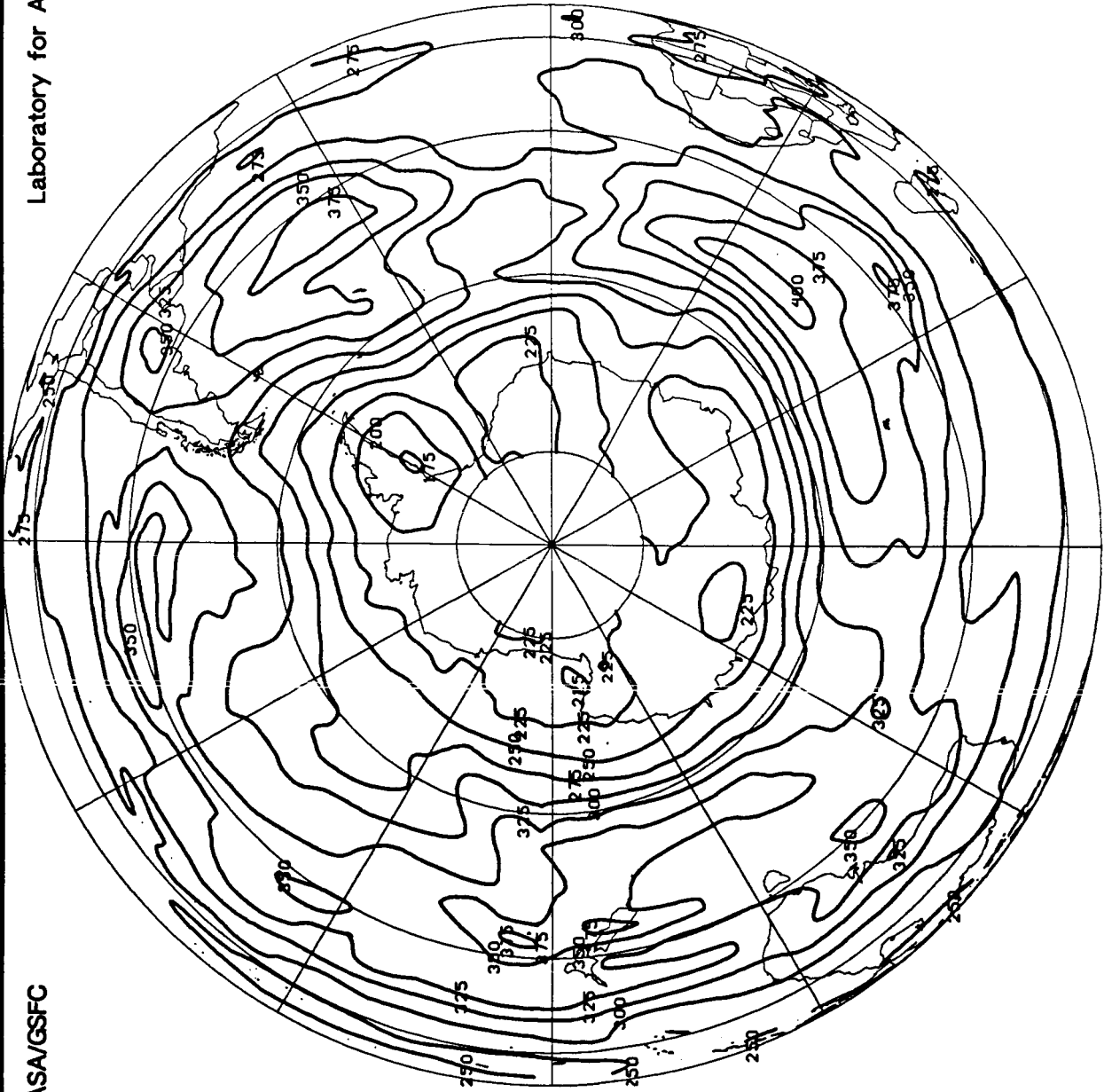

ORIGINAL PAGE IS
OF POOR QUALITY.

September 5, 1987

Gridded TOMS Ozone (Dobson Units)

Figure 21a. TOMS ozone distribution for the southern hemisphere on September 5, 1987.

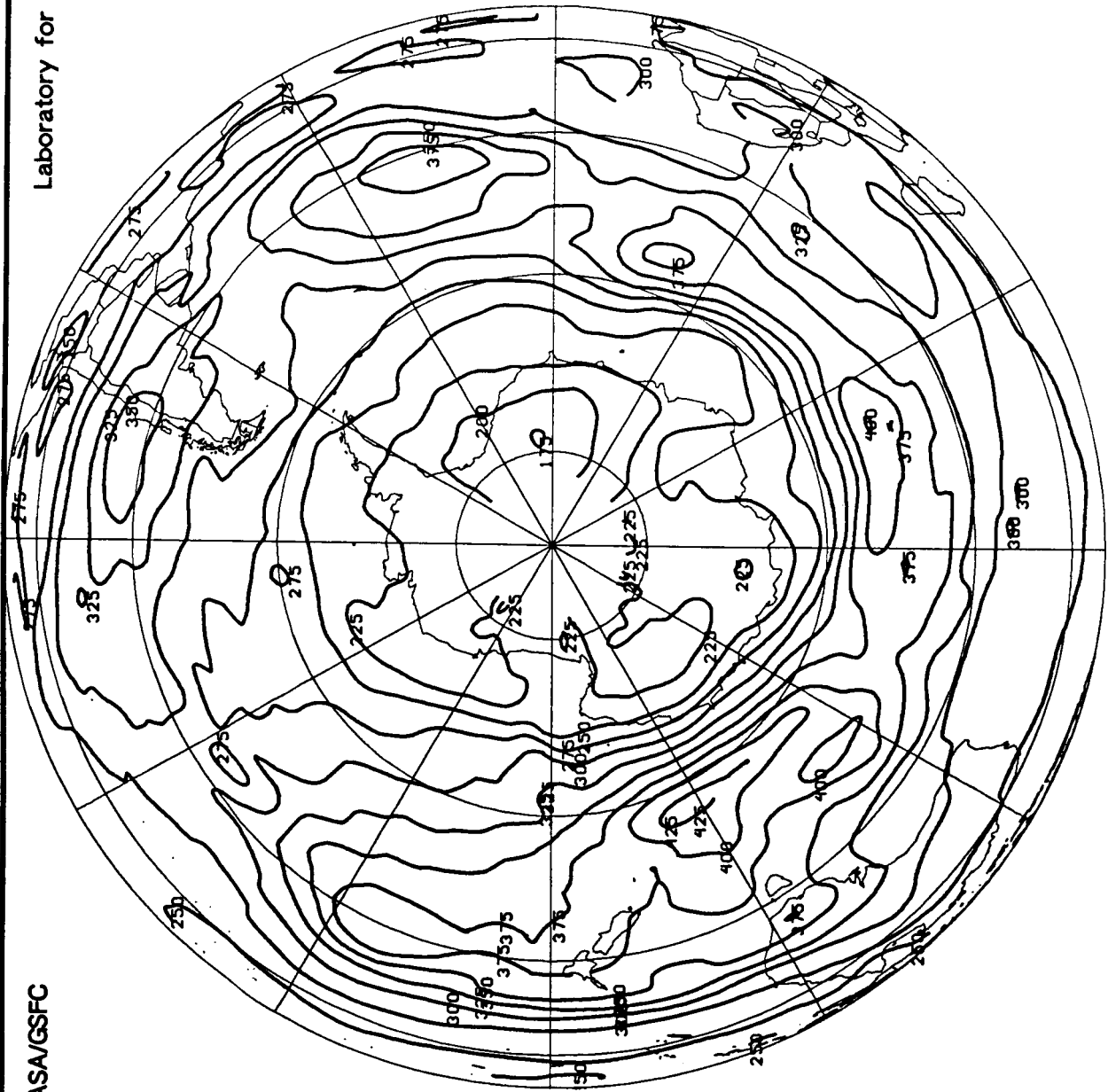

September 8, 1987

Gridded TMS Ozone (Dobson Units)

ORIGINAL PAGE IS
OF POOR QUALITY

Figure 21b. TMS ozone distribution for the southern hemisphere on September 8, 1987.

ORIGINAL PAGE IS
OF POOR QUALITY

Gridded TOMS Ozone (Dobson Units)

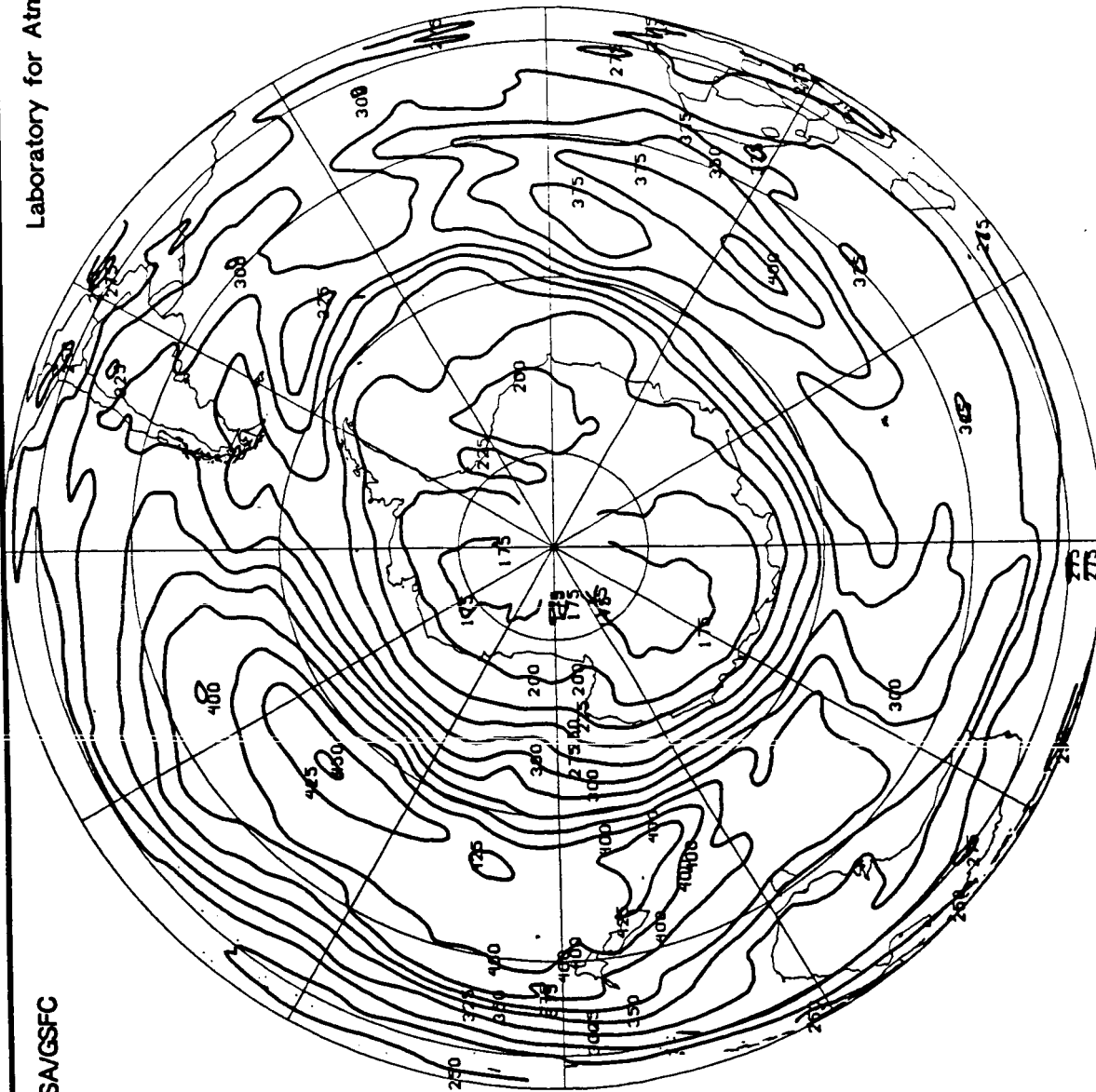

NASA/GSFC

September 15, 1987

Figure 21c. TOMS ozone distribution for the southern hemisphere on September 15, 1987.

on September 5. From September 5-8, the hole drifted eastward at about 10 m/s and came to rest over the continent on the Greenwich meridian and centered near 85°S. The hole then remained quasistationary, with little change in intensity, for the next week.

Ozone Profiles Show Initial Depletion

One of the most dramatic features in the initiation of the Antarctic ozone hole is the pronounced depletion of the ozone as shown by ozone profiles. Figure 22a-b shows that a center of depleted total ozone, or "mini-hole", moved over the Halley Bay station between August 26 and 29. The corresponding ozone partial-pressure profiles for those dates are given in Figure 23. Note the large reduction in the magnitude of the 70 mb ozone peak between 30 mb and 300 mb from August 26 to 29. Reference to profiles between the 26th and 29th (not given here) show that the ozone depletion first occurred on the underside of the ozone peak, i.e., between 70 mb and 300 mb. The total ozone change during this period was from 267 DU to 230 DU; a decrease of over 30 DU in three days. The accompanying temperature profiles in Figure 23 show that a temperature reduction of 2° to 3°C above 300 mb occurred with the depletion.

Figure 24 shows the effect of an even more spectacular reduction of ozone in the 30 mb to 90 mb layer as the mature ozone hole lay over Palmer station on October 9th. In that layer, the ozone was depleted to partial pressure values lower even than those present in the troposphere.

An illustration of how the ozone profiles change with time at a station over which the boundary of the ozone hole moves is given in Figure 25a-c. Ozone profiles for Palmer station are shown in this figure, along with the corresponding orbital-swath total ozone plots. It is seen, as noted before, that the ozone profile erodes as the location of the hole boundary fluctuates relative to the station.

7.3 Maturity of the Hole

The 1987 Antarctic ozone hole first assumed its general character on about September 5. Figure 26a shows the TOMS imagery for that date. As occurred so frequent in August, a mini-hole is present just east of the base of the Antarctic peninsula. But, unlike the others, this mini-hole remained, continued to deepen and expanded until it reached maturity in late October. A record low total ozone value of 109 DU was recorded by the TOMS instrument on October 5. This reading is consistent with the low values found independently with a Dobson spectrophotometer at Halley Bay station and reported by Farman (1987). The corresponding TOMS total ozone distribution at the day of the record minimum is illustrated in Figure 26b.

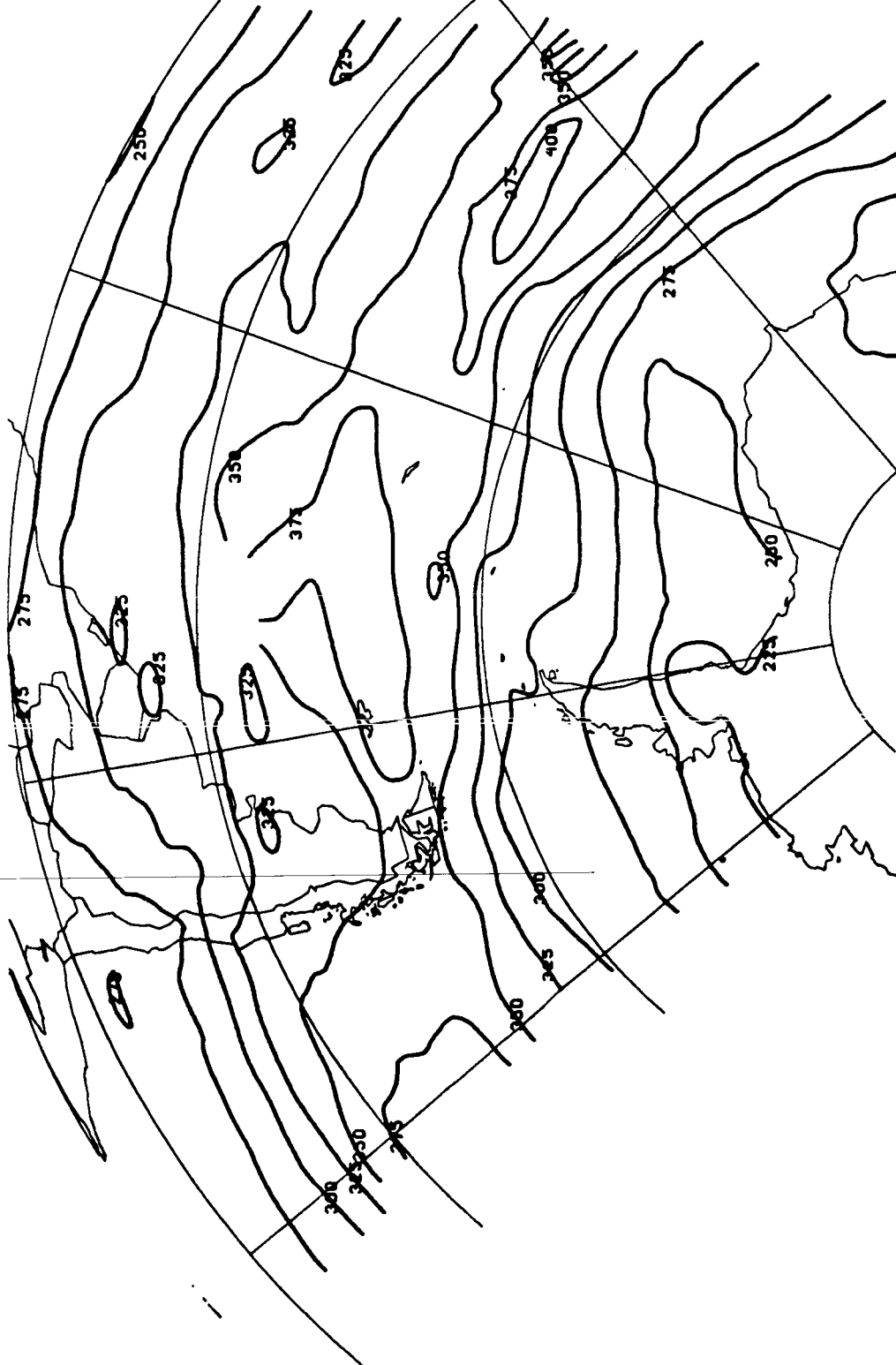

August 26, 1987

Orbital (44623-5) TMS Ozone (Dobson Units)

Figure 22a. Orbital TMS ozone contours for August 26, 1987 (orbits 44623-44625).

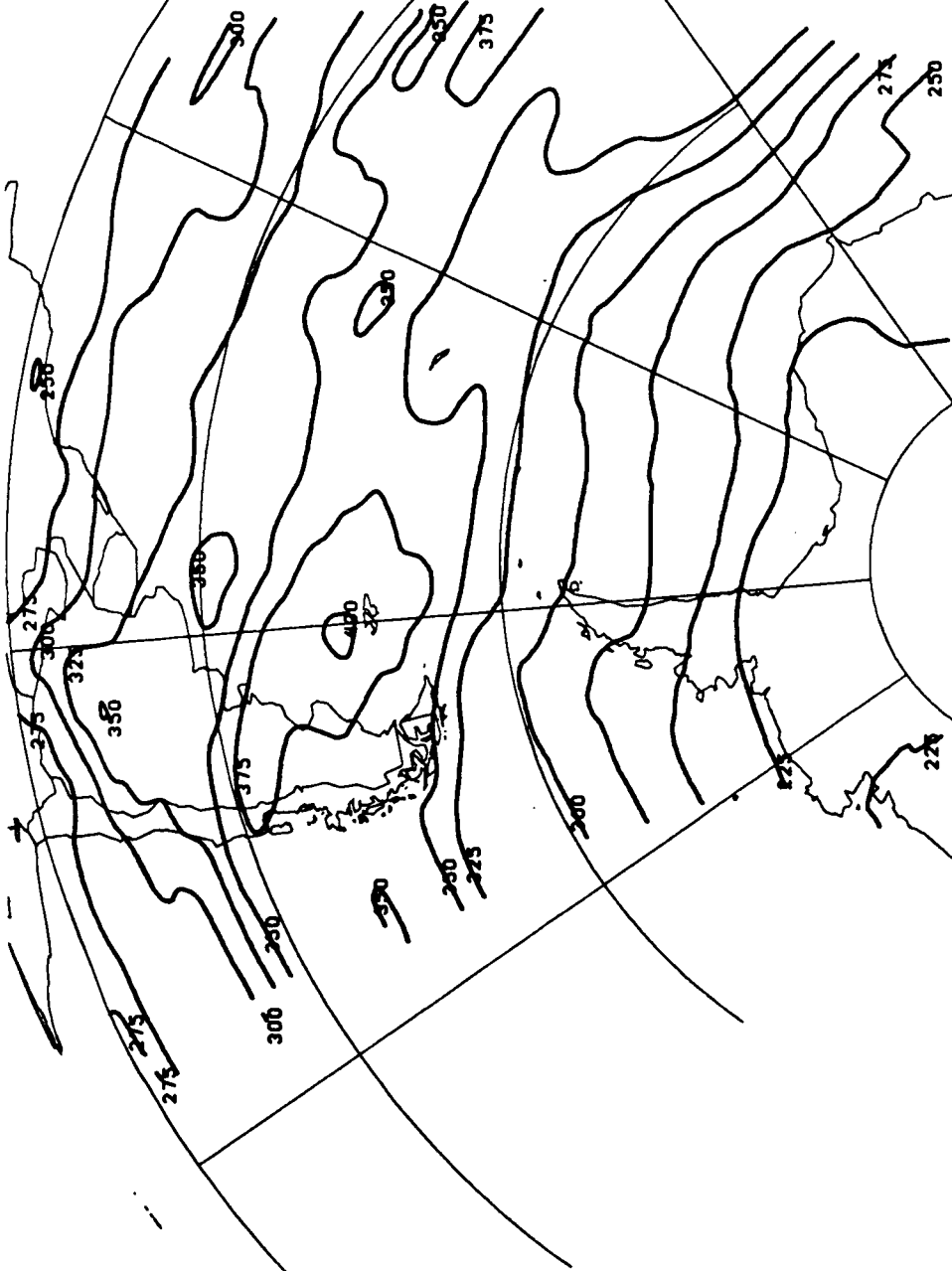

August 29, 1987

Orbital (44665-7) TOMS Ozone (Dobson Units)

Figure 22b. Orbital TOMS ozone contours for August 29, 1987 (orbits 44665-44667).

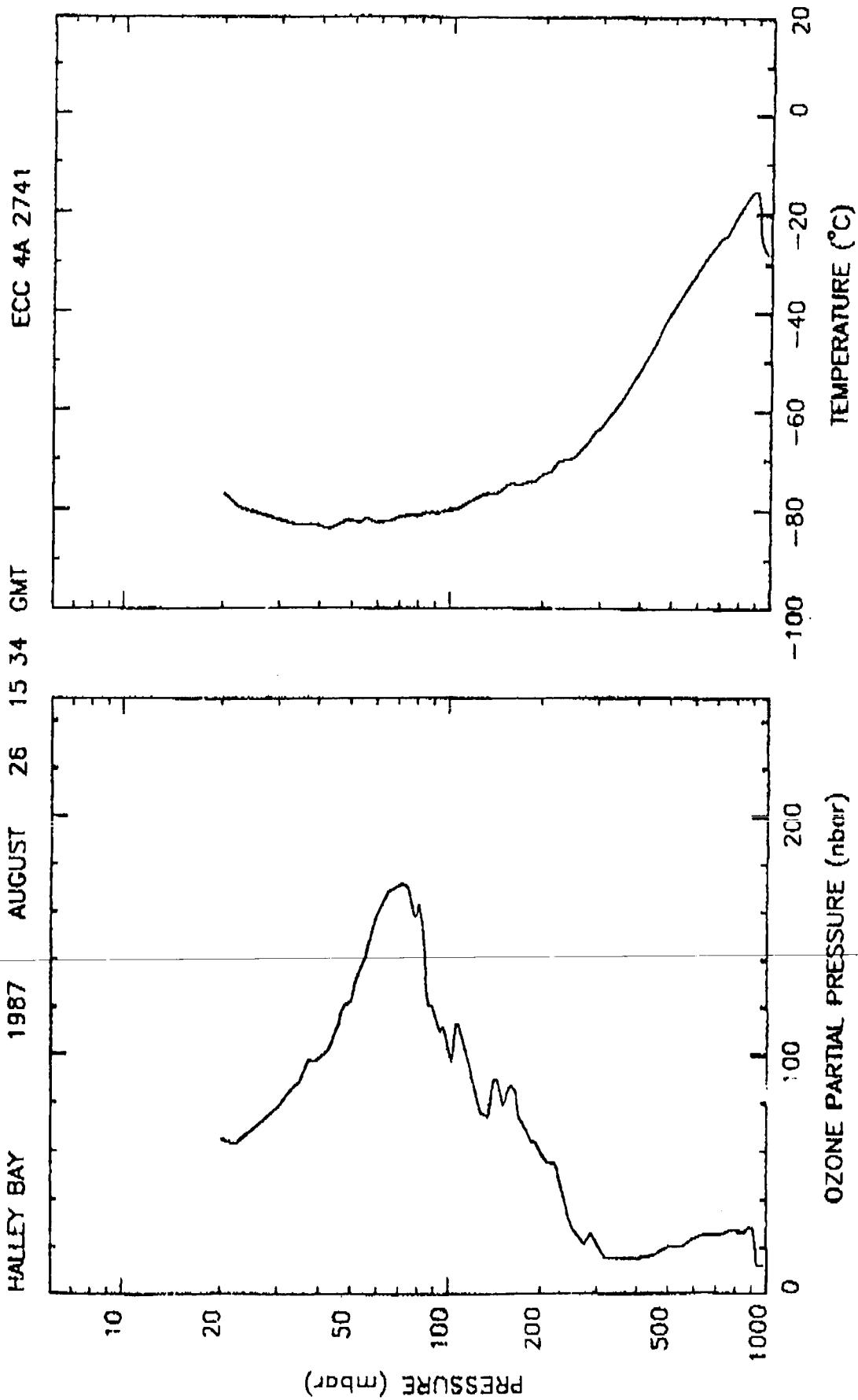

Figure 23a. Halley Bay vertical soundings of ozone partial pressure and temperature for August 26, 1987.

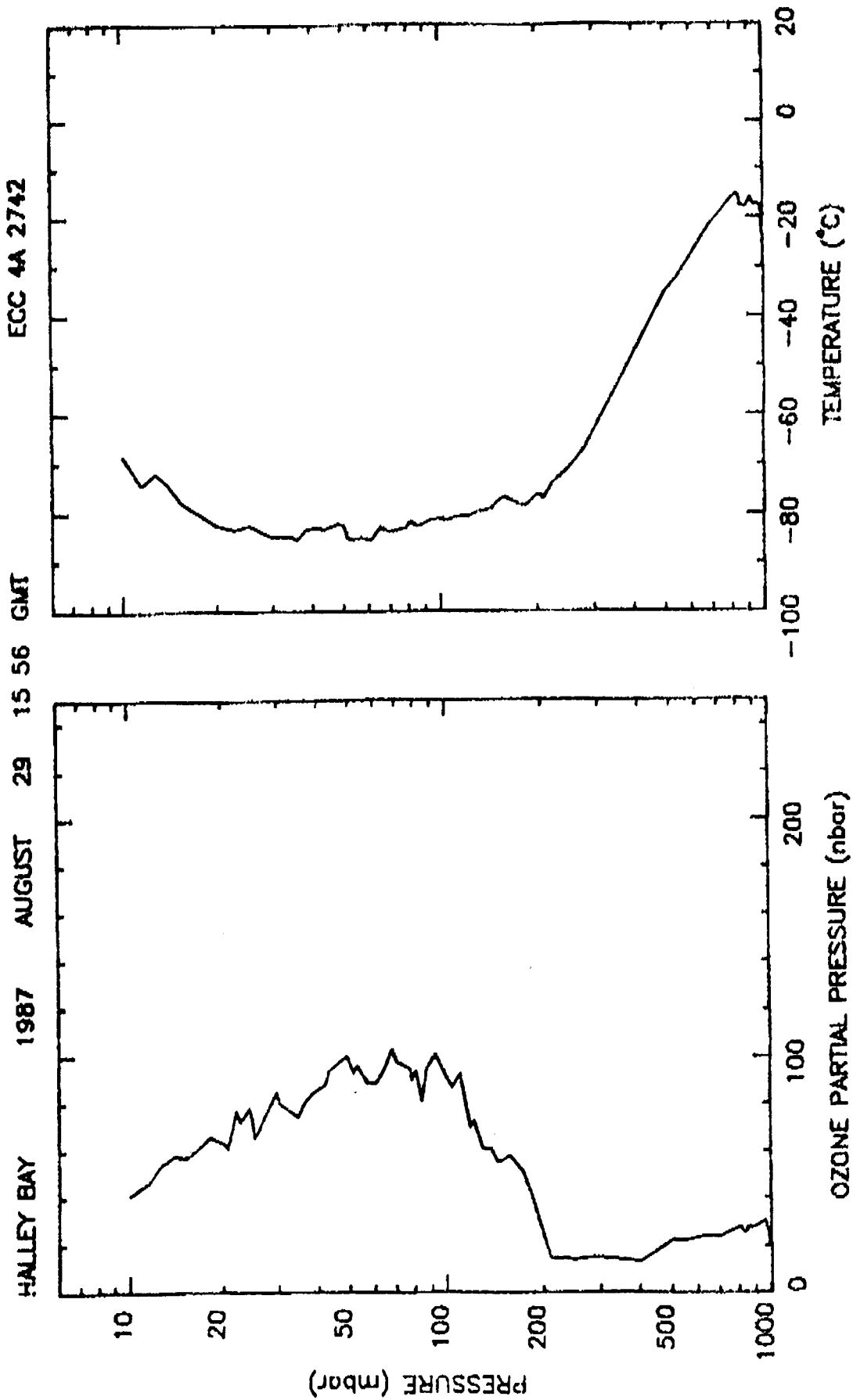

Figure 23b. Halley Bay vertical soundings of ozone partial pressure and temperature for August 29, 1987.

PALMER STATION OCTOBER 9, 1987

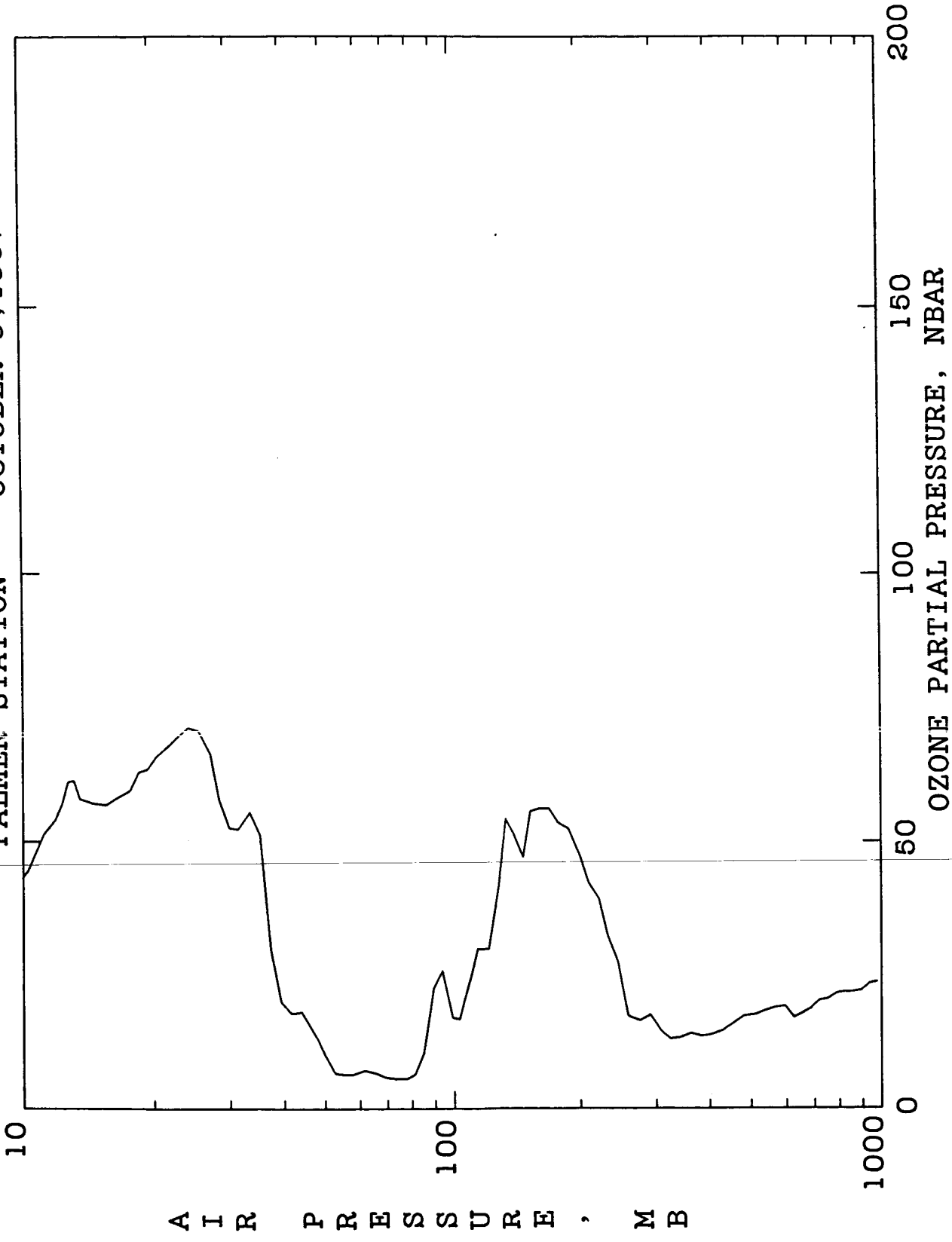

Figure 24. Palmer Station vertical sounding of ozone partial pressure for October 9, 1987.

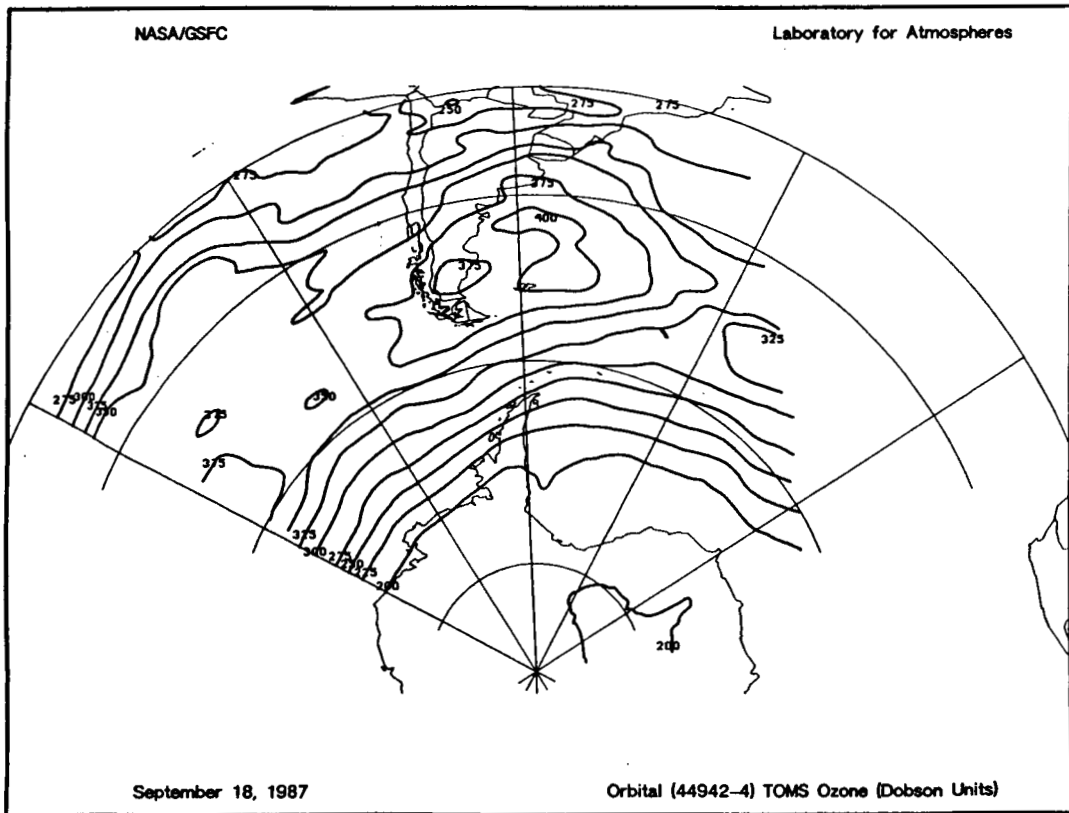
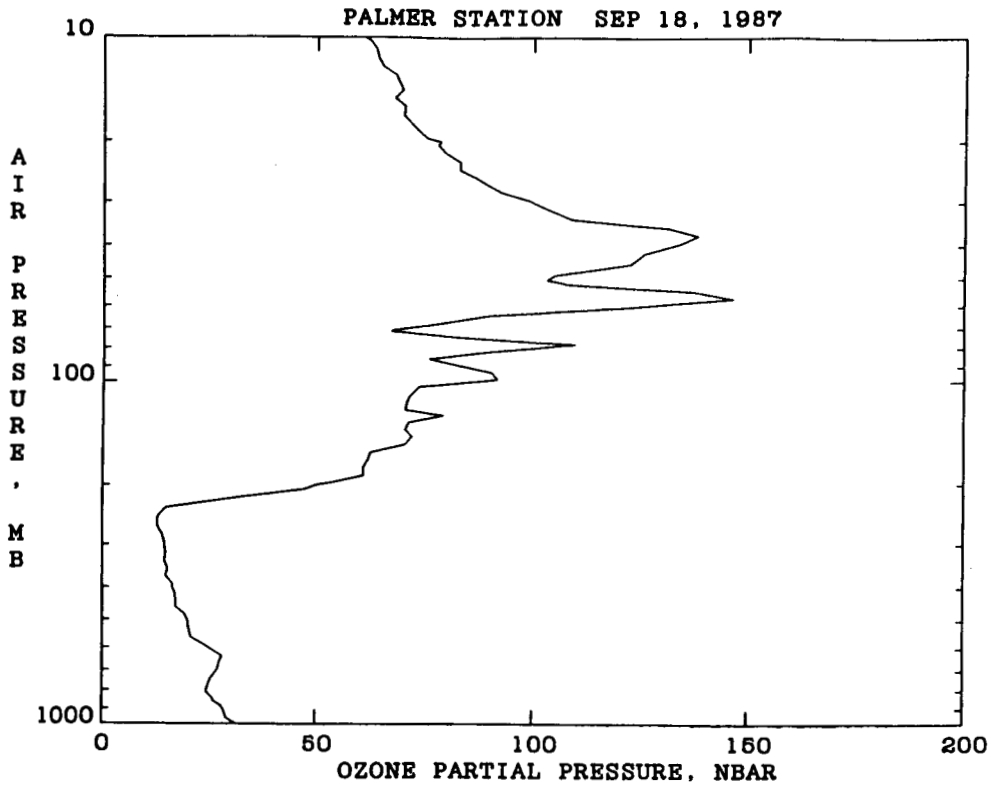

Figure 25a. Palmer Station vertical sounding of ozone partial pressure, along with the corresponding orbital-swath total ozone contour, on September 18, 1987.

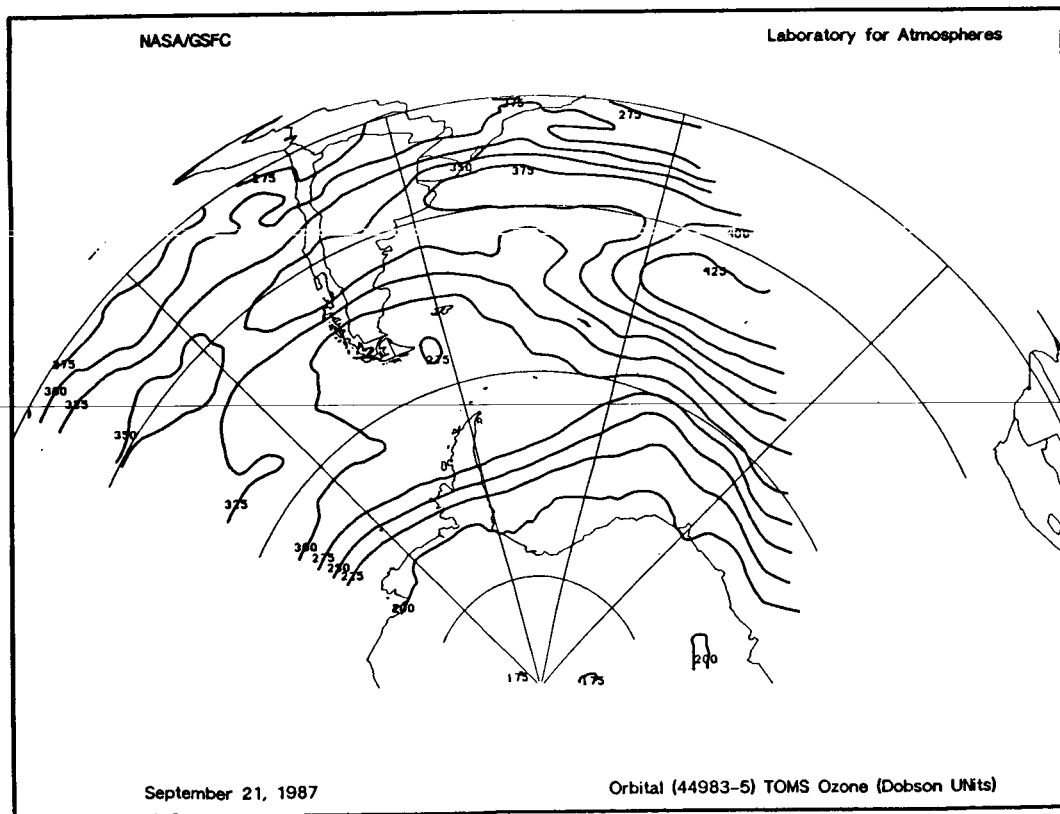
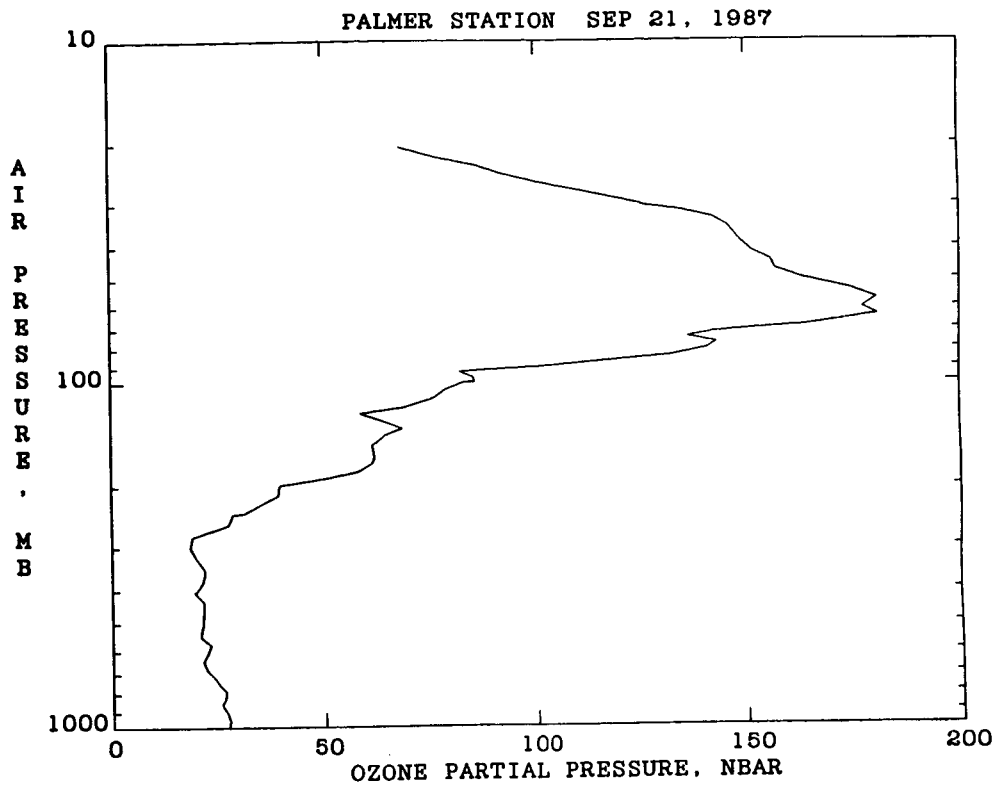

Figure 25b. Palmer Station vertical sounding of ozone partial pressure, along with the corresponding orbital-swath total ozone contour, on September 21, 1987.

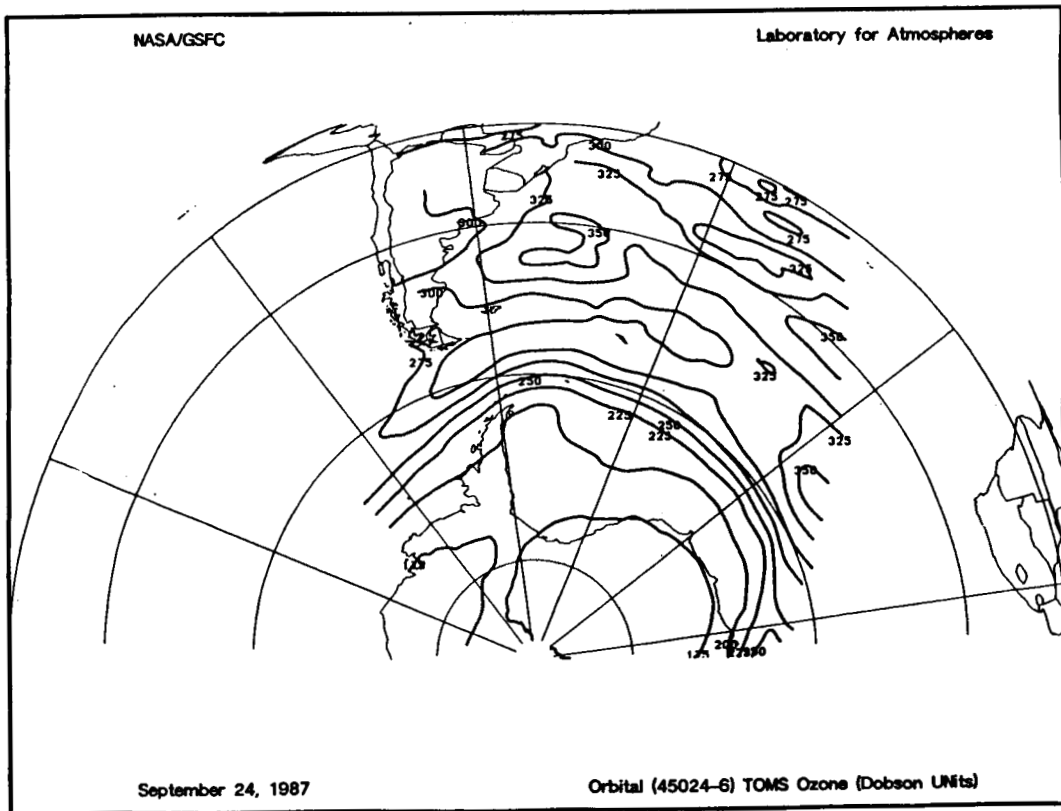
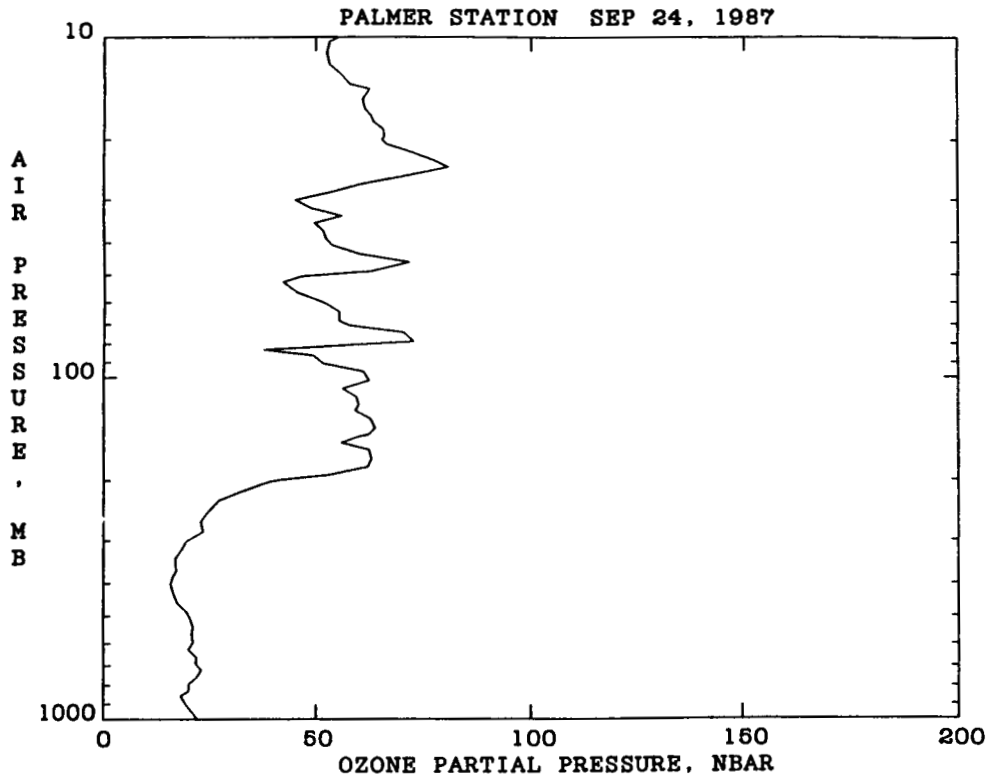
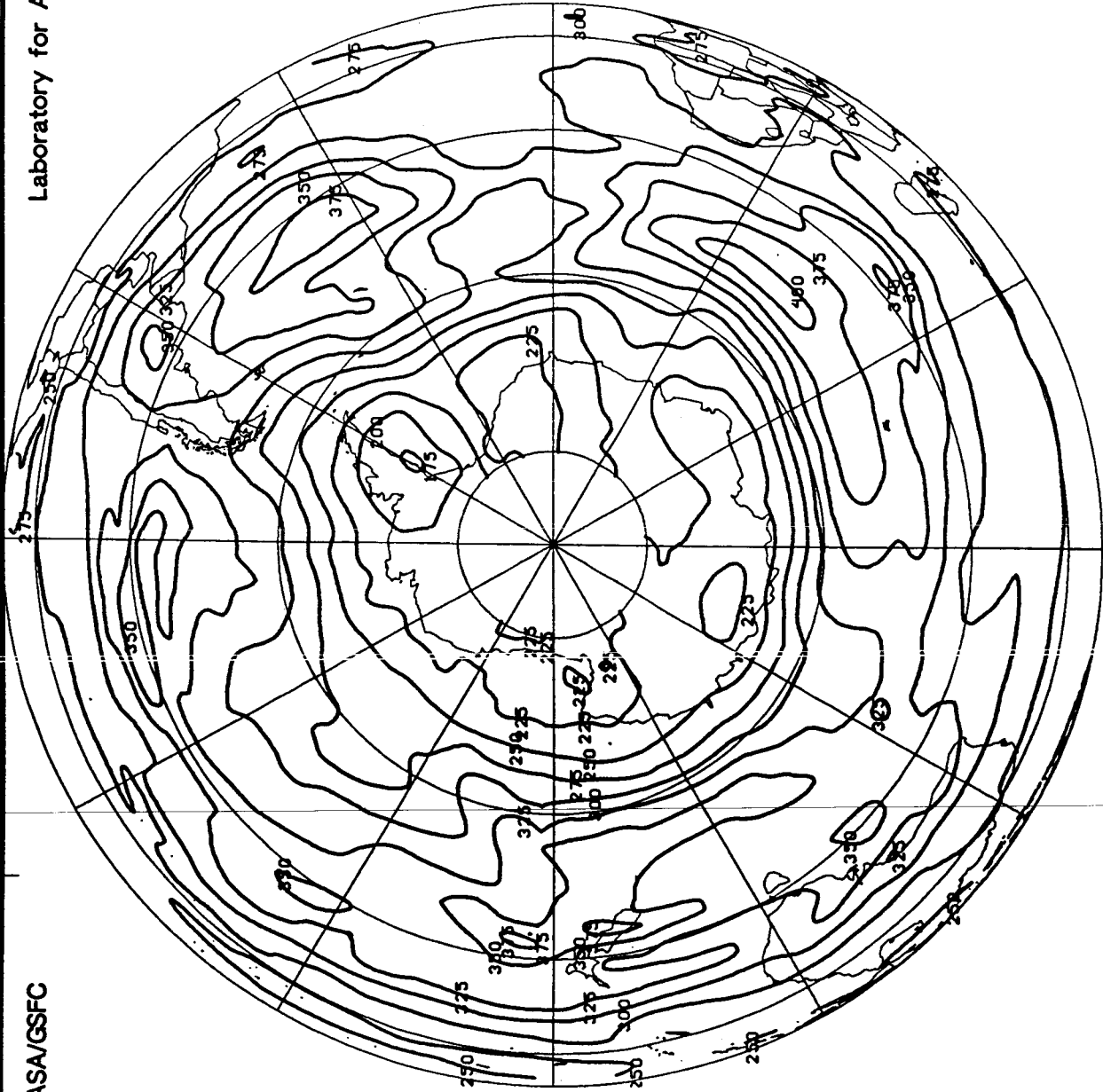

Figure 25c. Palmer Station vertical sounding of ozone partial pressure, along with the corresponding orbital-swath total ozone contour, on September 24, 1987.



Gridded TOMS Ozone (Dobson Units)

September 5, 1987

Figure 26a. TOMS ozone distribution for the southern hemisphere on September 5, 1987.

NASA/GSFC

Laboratory for Atmospheres

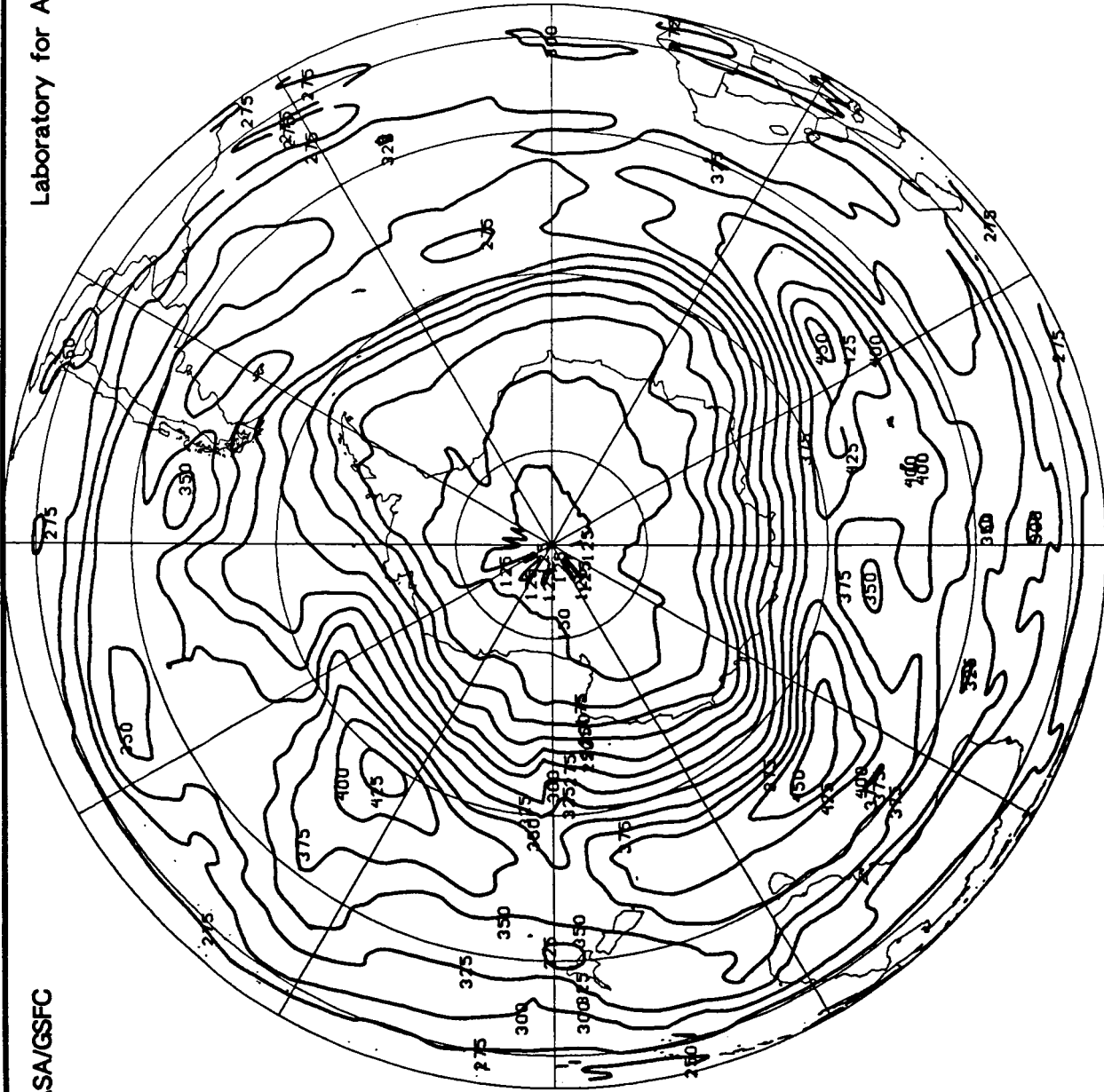

October 5, 1987

Gridded TOMS Ozone (Dobson Units)

Figure 26b. TOMS ozone distribution for the southern hemisphere on October 5, 1987.

ORIGINAL PAGE IS
OF POOR QUALITY

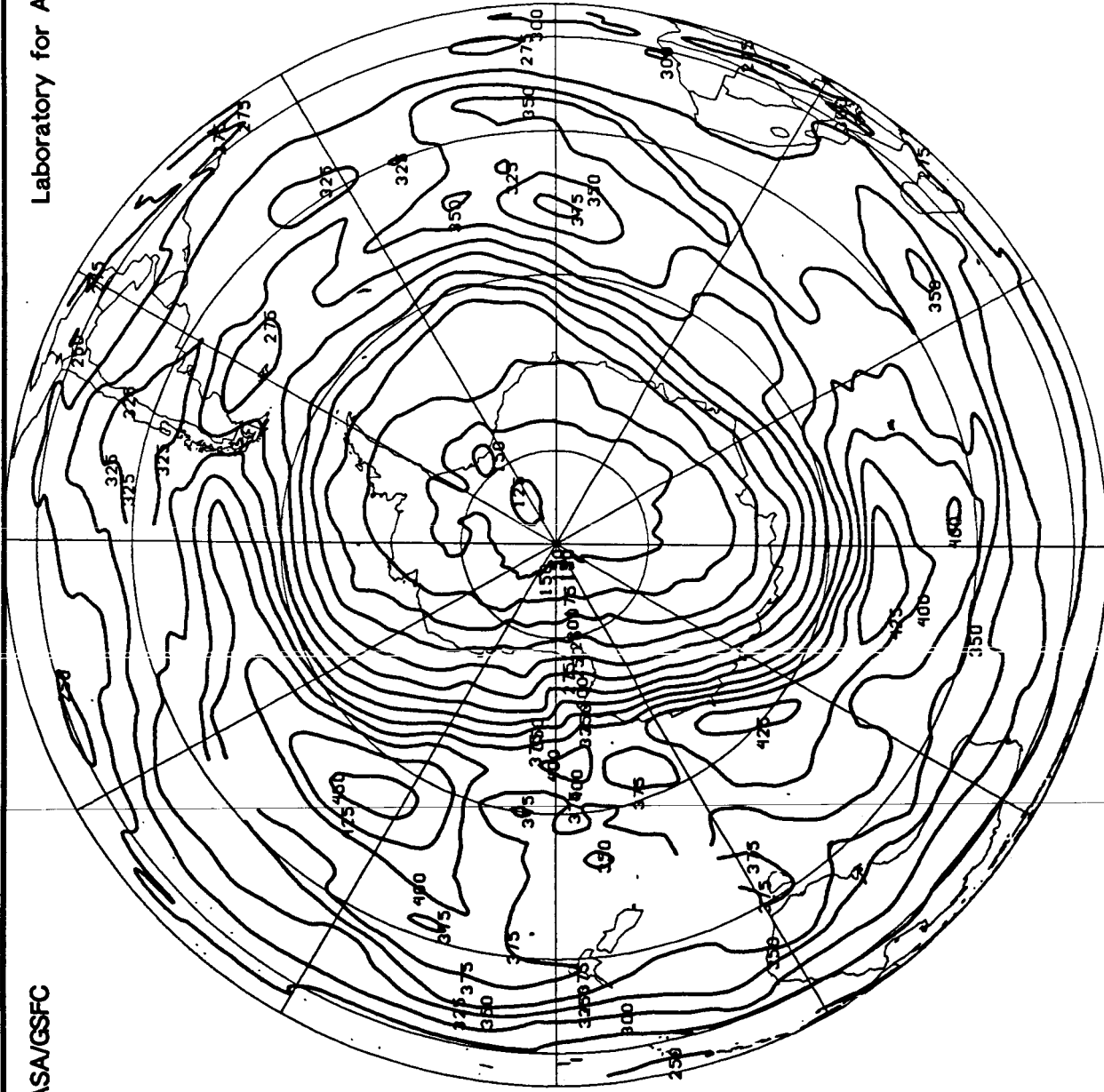

October 17, 1987

Gridded TOMS Ozone (Dobson Units)

Figure 26c. TOMS ozone distribution for the southern hemisphere on October 17, 1987.

From September 5th to 6th the total ozone as observed by TOMS decreased by 25 DU over a large area of the Weddell Sea. Such a rapid decrease is difficult to explain chemically, and one may ascribe this sudden deepening to unspecified meteorological causes.

Typically, and 1987 was no exception, the ozone hole rotates slowly eastward around the south pole and repeatedly changes its shape and orientation. The 1987 hole is unique in that it was generally much more symmetrical in shape and remained much closer to the pole than did the ozone holes of previous years. This is obvious from Figures 26b-c, which show the mature ozone hole which is symmetrical and centered near the pole. Some fluctuations in the location of the center is evident.

The Role of Temperature Advection

As stated at the outset, we will concern ourselves here only with the adiabatic aspects of the observed meteorological fields. Specifically, we will describe the adiabatic vertical motions which may be associated with total ozone changes. Total ozone amount is especially sensitive to vertical motions, because sinking stratospheric air brings ozone downward from a region of high ozone amount; thus, the total-columnar ozone thickness is increased. Conversely, air rising from the ozone-poor lower stratosphere reduces the thickness of columnar, or total, ozone.

Adiabatic vertical motions may be inferred from fields of temperature advection as shown, for example, by Panofsky (1968). If one expands the total derivative of potential temperature in pressure coordinates assuming adiabatic conditions and steady-state flow, one finds that the adiabatic vertical motion (ω) is given by:

$$\omega = \frac{\bar{\nabla} \cdot \bar{\nabla} \theta}{\sigma} \quad (1)$$

where $\bar{\nabla} \cdot \bar{\nabla} \theta$ is the negative potential-temperature advection and σ is the static stability. Of course, one expects these vertical motions to be quite small because of the large stabilities characteristic of the stratosphere. However, it should be kept in mind that, for each kilometer of descent in the stratosphere, the total ozone can be increased by as much as 50 DU. A one centimeter per second vertical velocity acting over a period of just over one day will move air downward one kilometer.

In any case, Equation (1) indicates that warm-air advection relates to upward vertical motion and that cold-air advection implies subsidence. Since the ECMWF and NOAA data sets used during the experiment provided winds and temperatures at various levels, it was easy to draw streamlines and isotherms in order to relate the temperature advectations to ozone changes. Several case Figure 26c. Polar ozone contours for October 17, 1987

studies will be presented to demonstrate the results of these investigations.

It should also be noted that we produced computer-generated temperature advection fields on a daily basis at GSFC. These calculations were made from the NOAA-provided 50 mb and 70 mb data. Figures 16 through 18 should now be compared for purposes of consistency checks between the various analyses.

Ozone Advection

The previous section dealt with the role of vertical motion in total ozone changes. Of course, the total ozone distribution may be changed by horizontal advectations as well. Clearly, both the horizontal advectations and the vertical advectations must be considered. At the time of this writing, no computer-generated horizontal ozone advection calculations have been produced. However, it is possible to infer these from inspection of the wind and total ozone fields.

Another problem in studying horizontal ozone advection involves the need to find an appropriate advecting wind. Since only digital data for the 50 mb and 70 mb levels were available, these data must be used. But, it must be remembered that total ozone is an integrated amount and not necessarily well represented by the 50 mb and 70 mb levels.

Temperature Advection Patterns

Generally, as pointed out earlier, temperature advectations were quite small prior to the appearance of the ozone hole. When the actual hole appeared on September 5, the wind and temperature patterns became much less concentric and stronger advectations became apparent.

Figure 27a gives the total ozone distribution for September 13, 1987. There is a small minimum of total ozone over the continent, which is nearly centered on the Greenwich meridian. Across the continent, between 90°E and 110°E longitude, is a second total ozone minimum of nearly the same size, though with slightly higher magnitudes.

The temperature advectations on the 13th are given in Figure 27b. The only significant advection is warm and over the Weddell Sea area. Again, low ozone related to implied ascent.

At a later date, September 16, 1987, the total ozone between 90°E and 110°E has been reduced appreciably, while the ozone minimum near the Greenwich meridian has shrunk slightly as seen in Figure 28a. Corresponding to this altered total ozone pattern is the temperature advection pattern in Figure 28b. Note that the advectations over the Weddell Sea have been reduced (less ascent, less ozone) and the warm advection over the region near 110°E have intensified. The latter fact is again consistent with the

NASA/GSFC

Laboratory for Atmospheres

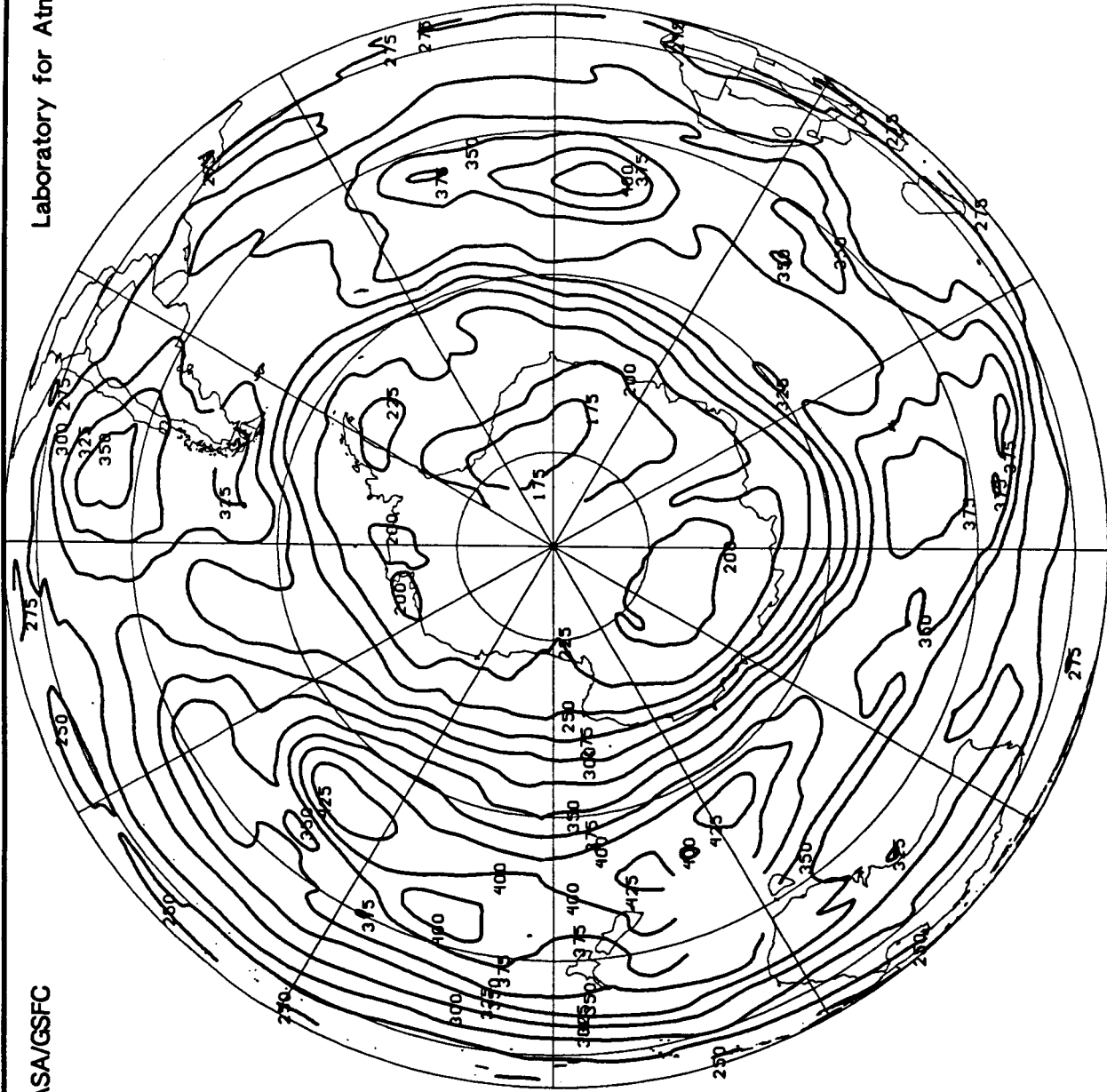

September 13, 1987

Gridded TOMS Ozone (Dobson Units)

Figure 27a. TOMS ozone distribution for the southern hemisphere on September 13, 1987.

ECMWF ANALYSIS 70hPa winds and temperatures vt: Sunday 13 September 1987 12z no: 7

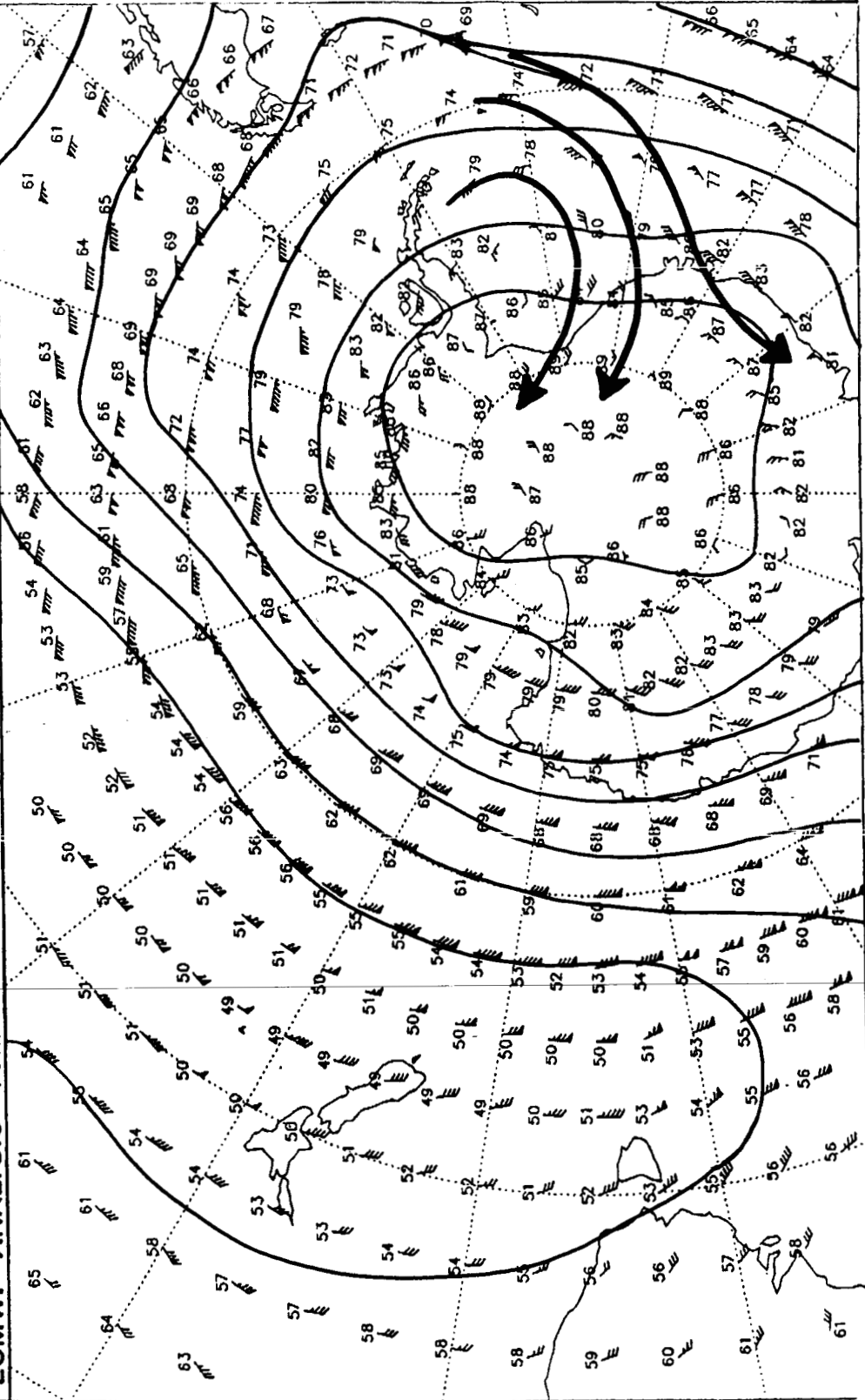
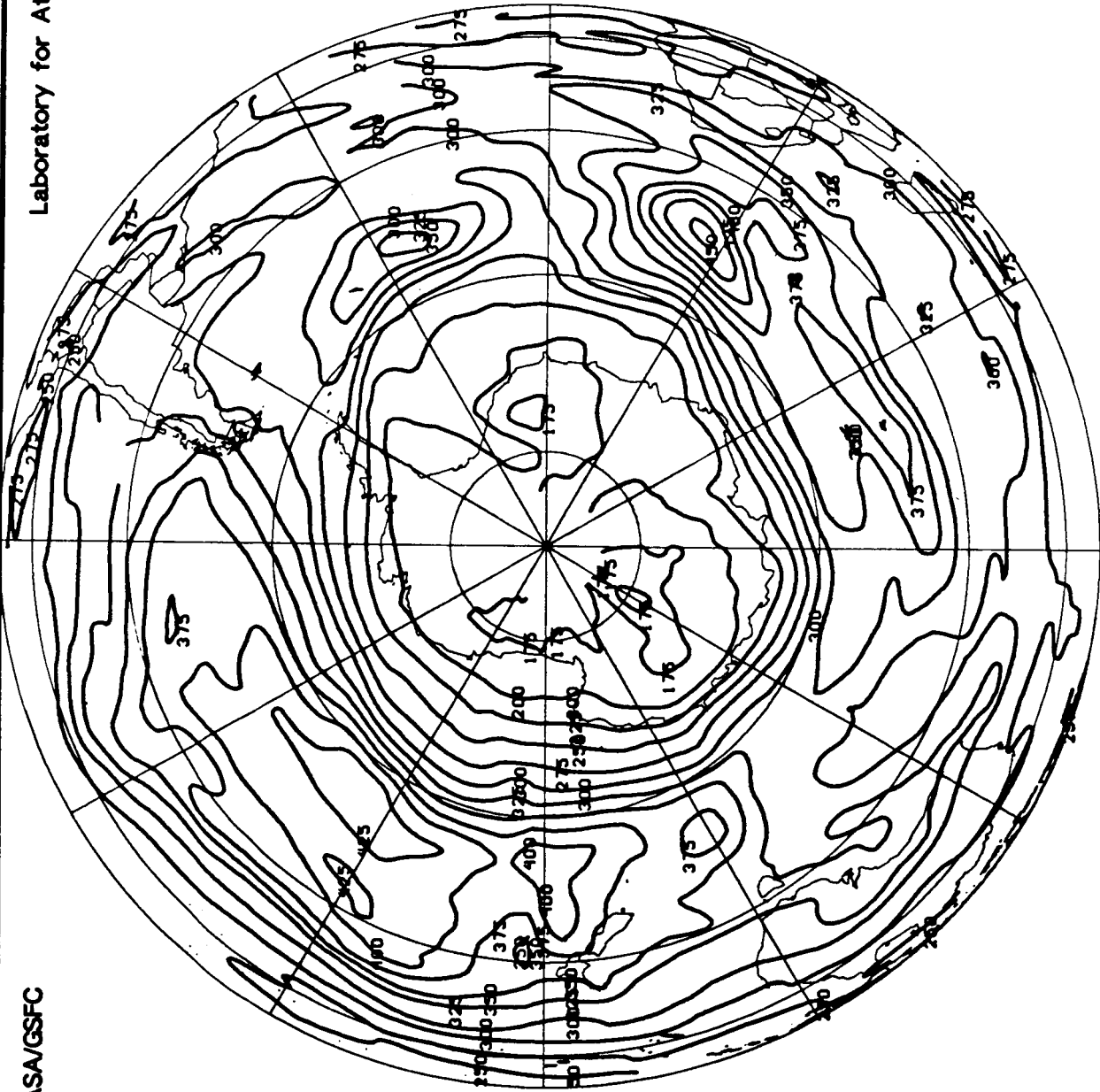

Figure 27b. ECMWF 70 mb analysis for September 13, 1987. Temperatures are in °C with minus signs omitted; arrows indicate direction of the wind.

NASA/GSFC

Laboratory for Atmospheres



September 16, 1987

Gridded TOMS Ozone (Dobson Units)

ORIGINAL PAGE IS
OF POOR QUALITY

Figure 28a. Orbital TOMS ozone contours for September 16, 1987.

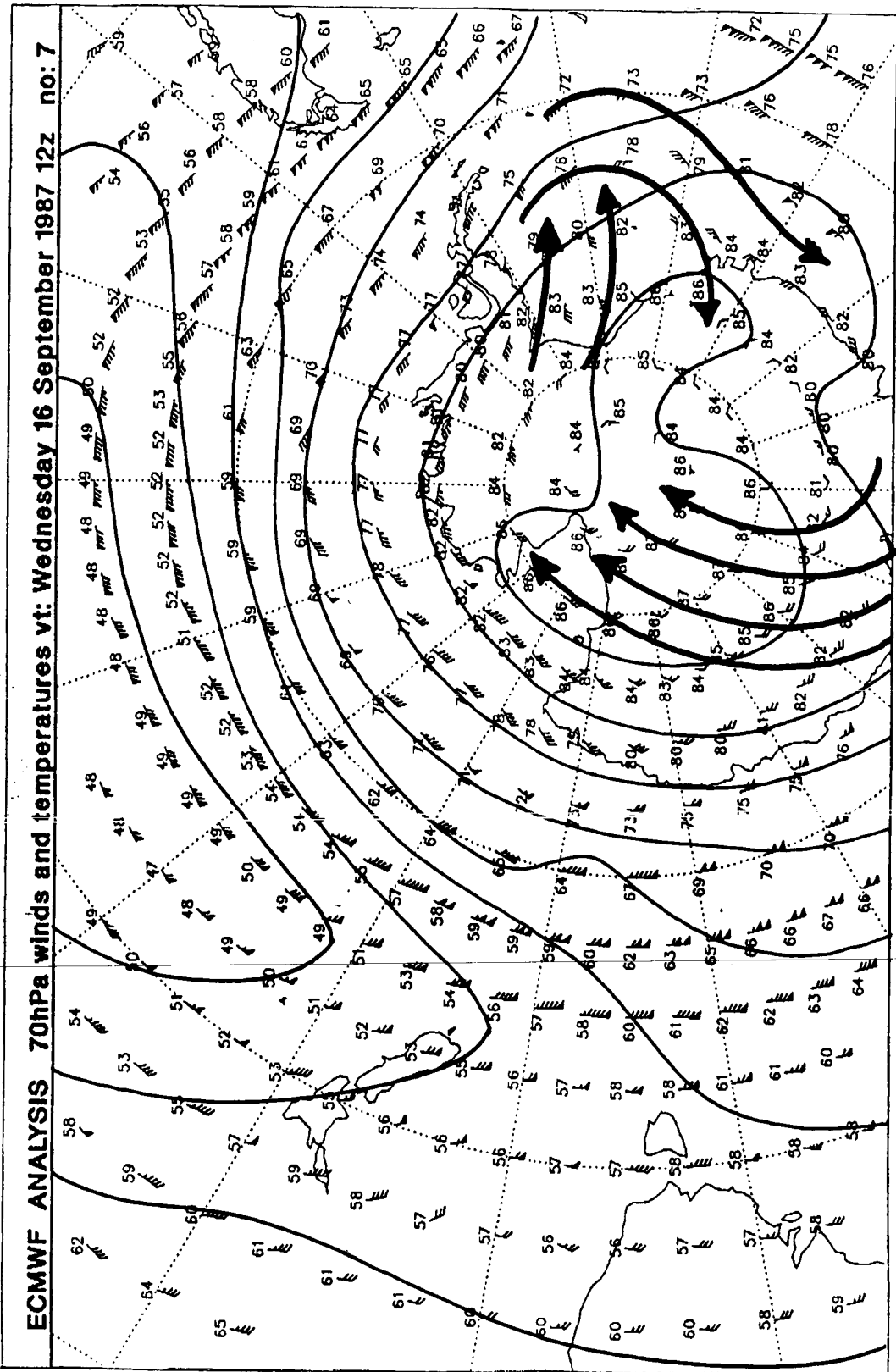

Figure 28b. ECMWF 70 mb analysis for September 16, 1987. Temperatures are in °C with minus signs omitted; arrows indicate direction of the wind.

observation that increased warm advection is associated with ascent and a reduction in the total-columnar ozone.

In Figure 29a, total-ozone minimum appears (near local noon on September 5) at the base of the Antarctic peninsula with values between 150 to 175 DU. Figure 29b shows that, for the same region (but at 12 GMT, some 4 to 5 hours earlier), the temperature advectations are quite strong. There is strong warm advection over the western part of the continent and strong cold advection over the eastern half. It should be noted that while warm advection implies the vertical advection of ozone-poor air from below, it also implies a horizontal ozone advection of unknown sign. Thus, as the hole develops, and steep ozone gradients develop along its fringe, horizontal advectations are no longer negligible and, in fact, become important. Flow from the interior of the hole is ozone-poor, yet results in cold advection enhancing ozone abundance. The flow of air from areas external to the hole is richer in ozone, but is warmer, producing sinking and ozone depletion. As a result of these compensations, partial or total cancellation of the advection terms may result. In this case, quasi-stationary patterns form, such as the standing wave evident in Figure 29a off the Palmer Peninsula, which was noted to recur sporadically throughout the experiment (e.g., on August 17). In these instances, the total ozone field will not necessarily correspond to pattern directly inferable from the horizontal thermal advection field (Figure 29b). The minimum ozone seems to occur at the boundary of the cold and warm temperature advectations.

Meridional Gradients

In its maturity, the ozone hole invariably exhibits extremely tight total ozone gradients in mid-latitudes. In the troposphere meteorologists associate tight gradients with fronts. Fronts imply vertical wind shear with jet streaks above regions of strong horizontal temperature contrasts. It is, therefore, understandable that one would like to relate the total ozone gradients of the ozone hole to the corresponding temperature gradients and jet winds in the stratosphere. After all, it would be surprising if the total ozone did not respond to some frontogenetical action. To show that there are no big surprises, Figure 30 is presented below. Figure 30a gives the total ozone distribution for the southern hemisphere as it appeared on September 27, 1987. (Although the hole reached peak maturity with maximum gradients in October, as of this writing no ECMWF data were available after September 27th when the telecommunications network associated with the 1987 Airborne Antarctic Ozone Experiment essentially terminated.) The strongest total ozone gradients in Figure 30a appear in the vicinity of 60°S. These strong gradients more or less coincide with the 70 mb temperature gradients shown in Figure 30b and the jet stream location given in Figure 30c. The total ozone gradient appears strongest on the cyclonic-shear side of the jet, and is bounded by the jet axis. Thus, the entire ozone hole is bounded by the circumpolar jet axis. As the axis deforms, such as

NASA/GSFC

Laboratory for Atmospheres

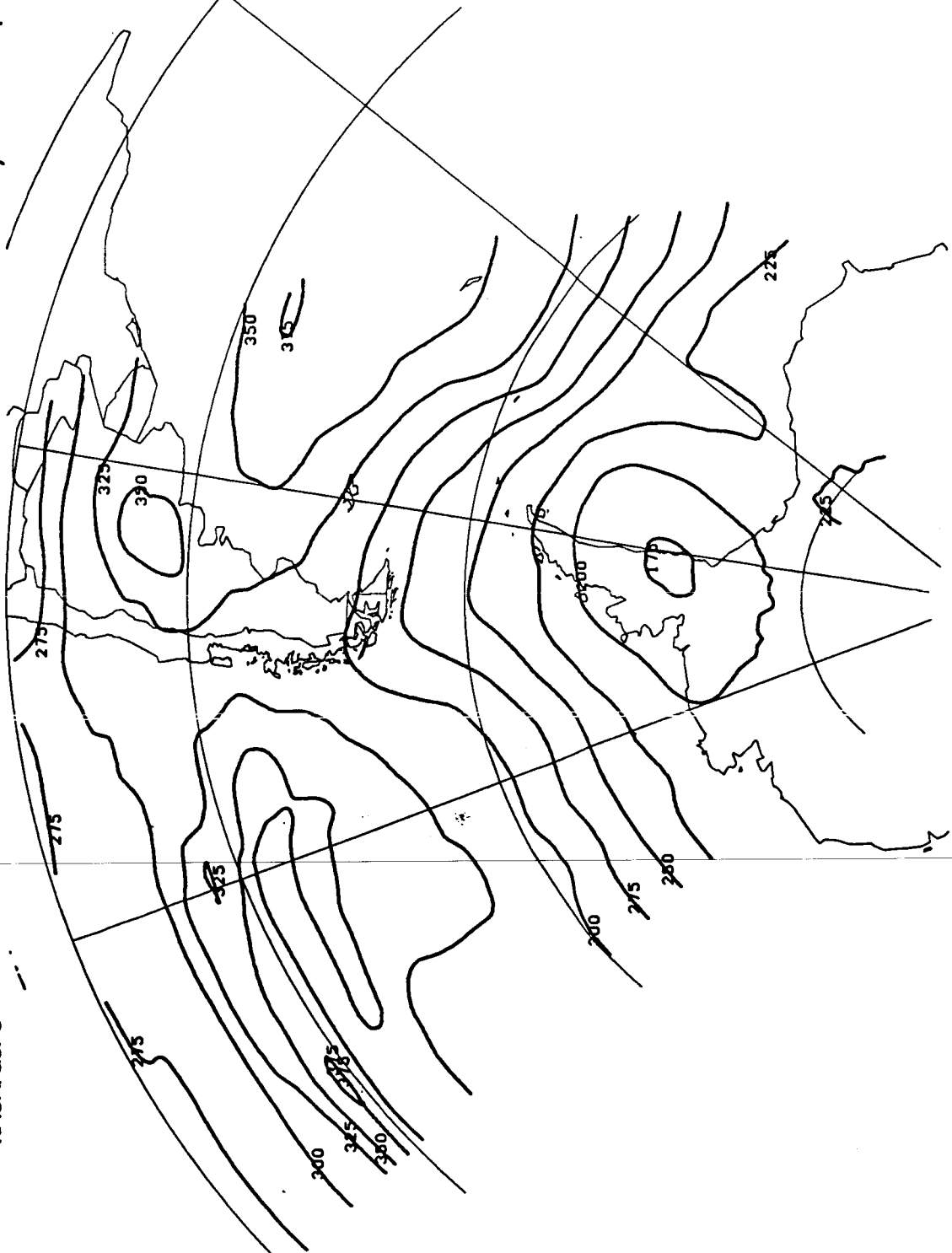

September 5, 1987

Orbital (44763-4) TOMS Ozone (Dobson Units)

Figure 29a. TOMS ozone distribution for the southern hemisphere on September 5, 1987.

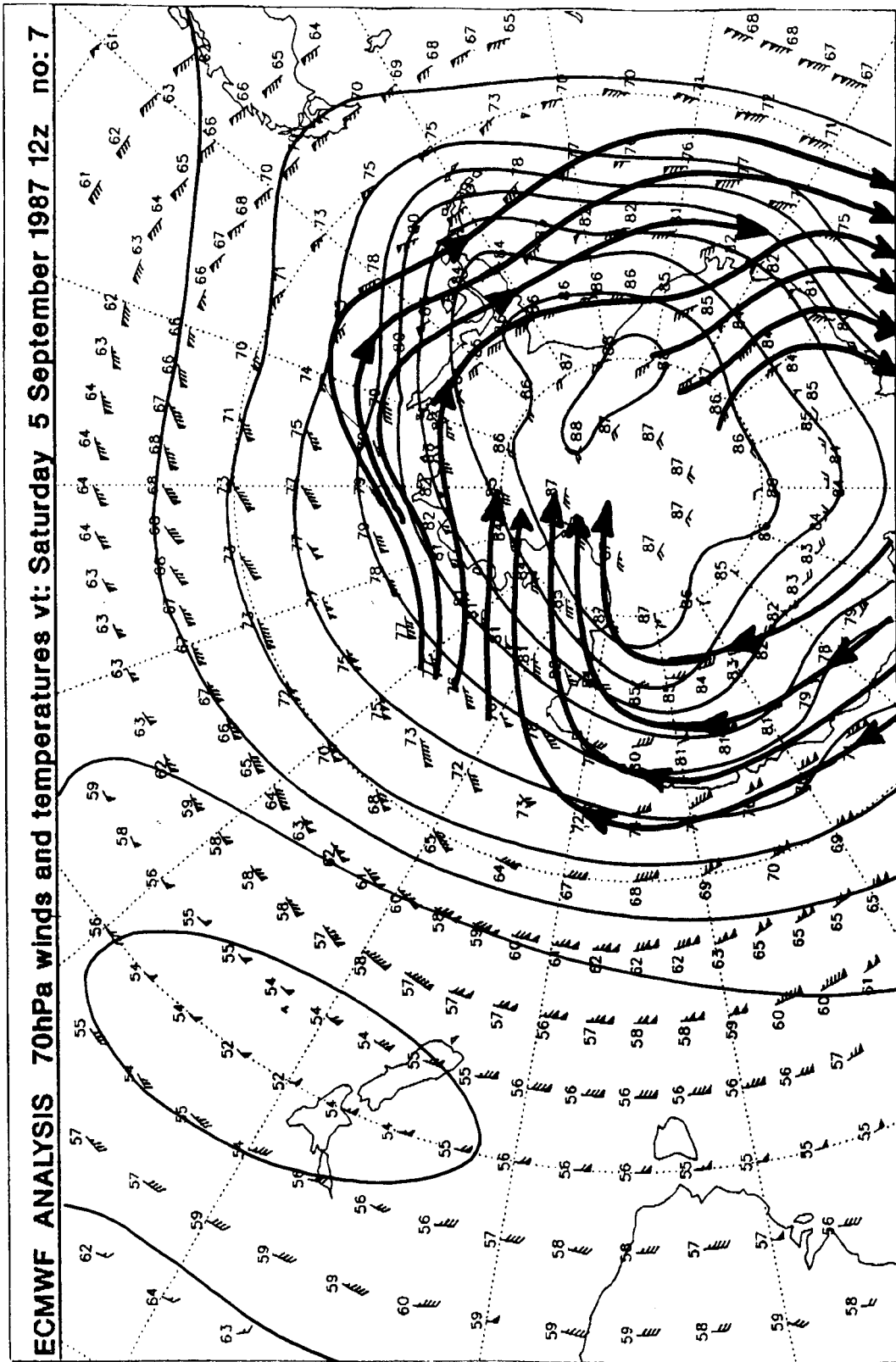
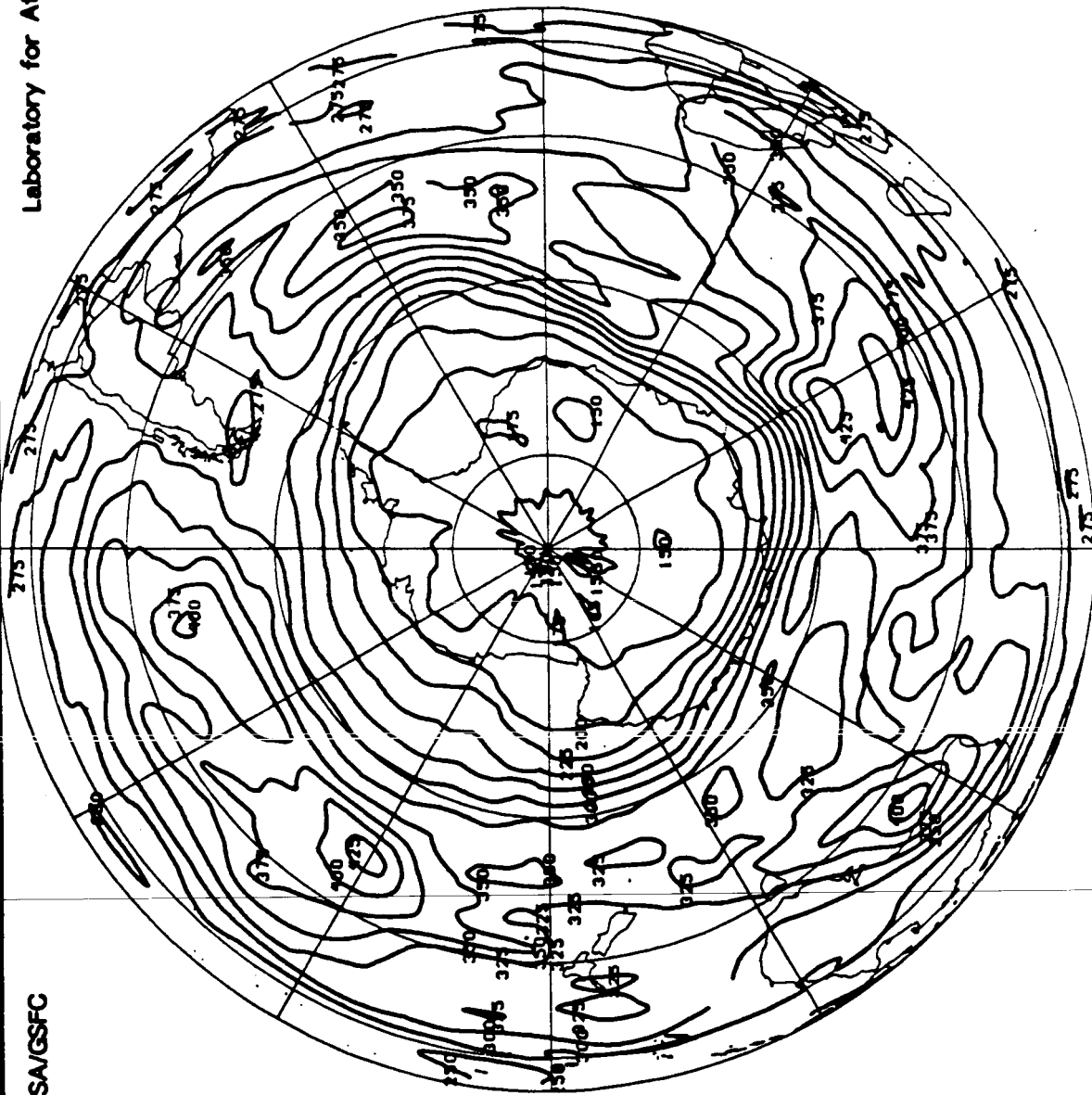

Figure 29b. ECMWF 70 mb analysis for September 5, 1987. Temperatures are in °C with minus signs omitted; arrows indicate direction of the wind.

Laboratory for Atmospheres

ORIGINAL PAGE IS
OF POOR QUALITY



NASA/GSFC

Gridded TOMS Ozone (Dobson Units)

September 27, 1987

Figure 30a. TOMS ozone distribution for the southern hemisphere on September 27, 1987.

ECMWF ANALYSIS 70hPa winds and temperatures vt: Sunday 27 September 1987 12z no: 7

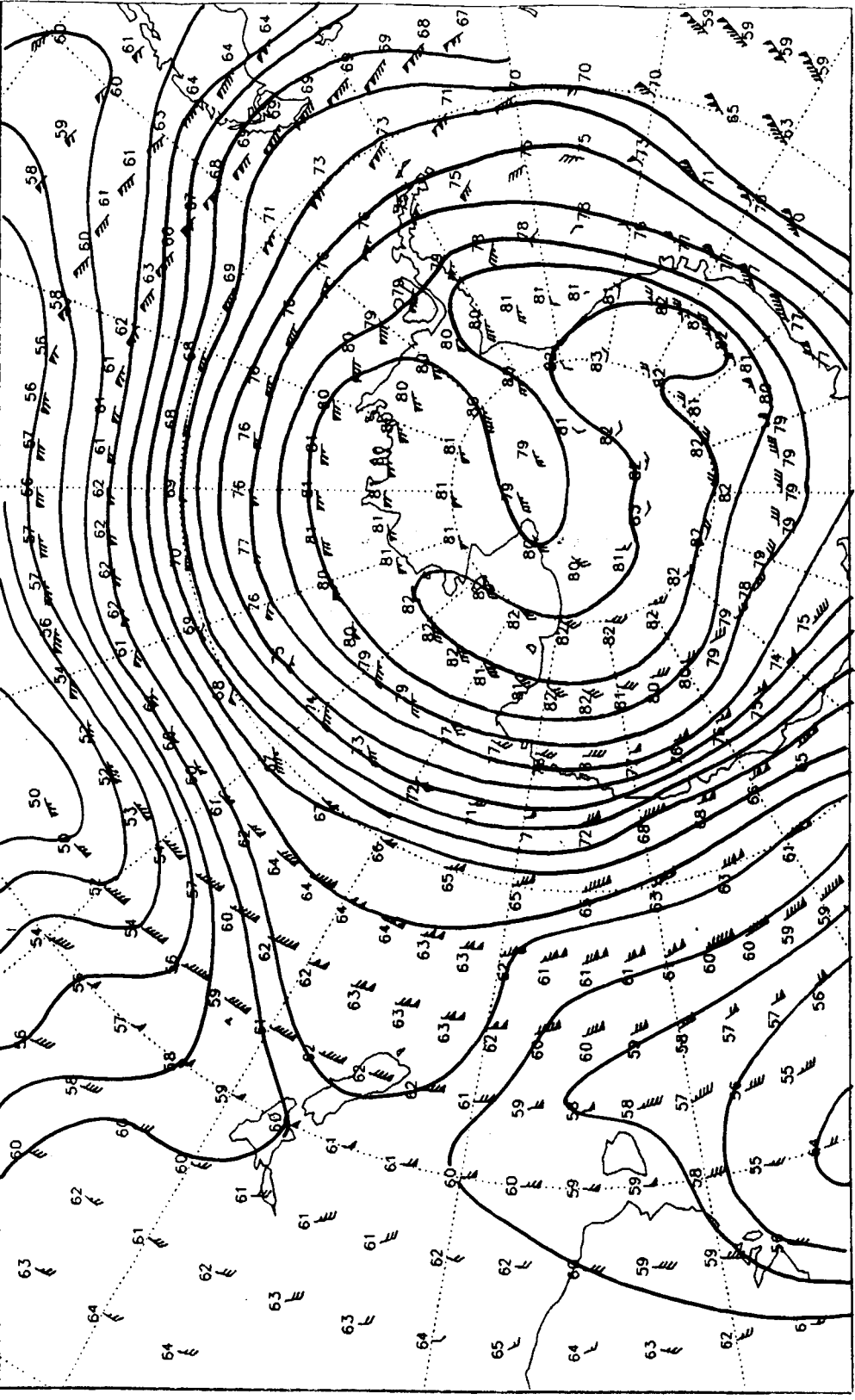

Figure 30b. ECMWF 70 mb analysis for September 27, 1987. Temperatures are in °C with minus signs omitted.

ECMWF ANALYSIS 70hPa winds and temperatures vt: Sunday 27 September 1987 12z no: 7

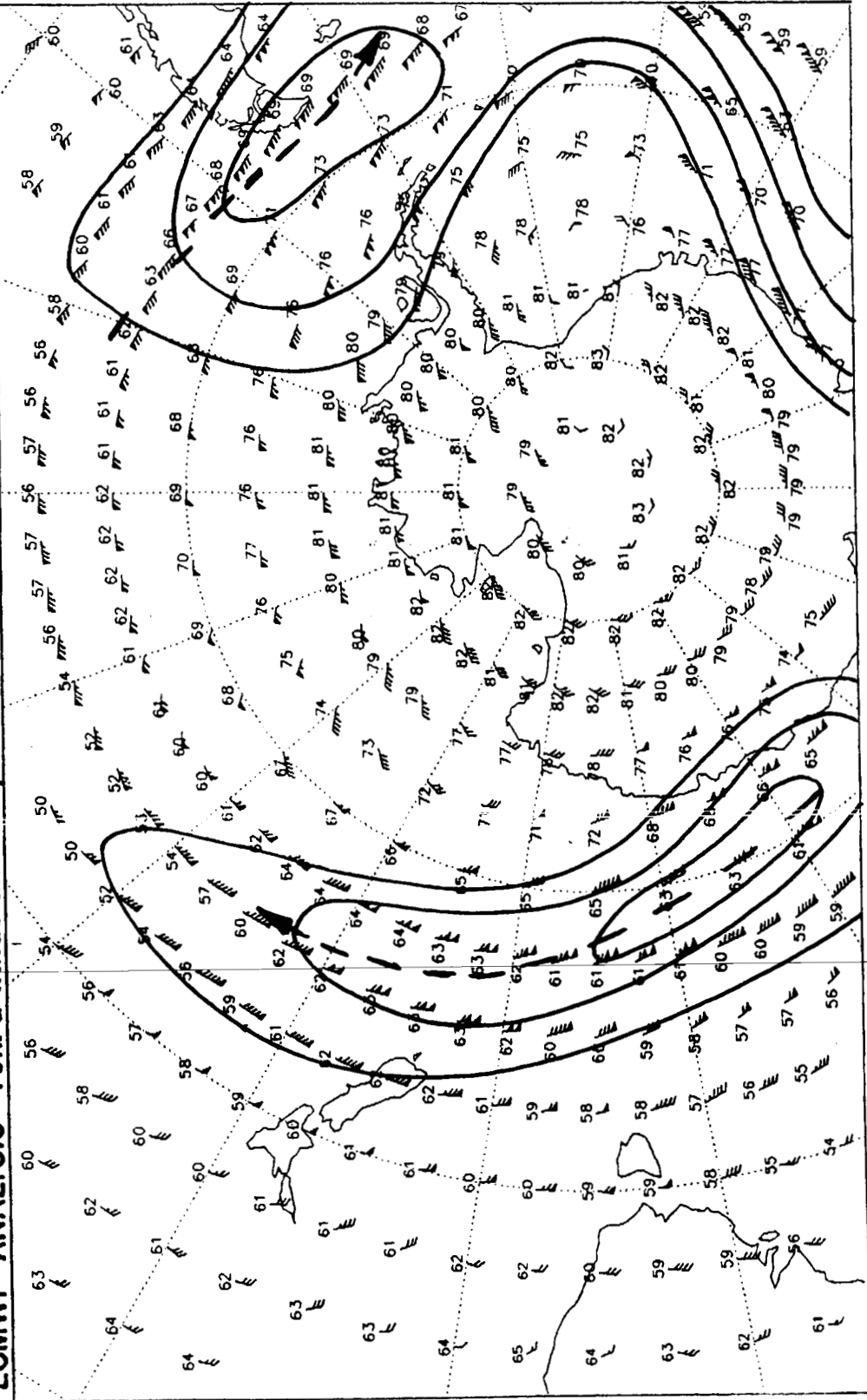

Figure 30c. ECMWF 70 mb analysis for September 27, 1987. Temperatures are in °C with minus signs omitted. Contours are isotachs with arrows indicating jet axis.

at 20°W on this day (Figure 30c) so does the boundary of the ozone hole (Figure 30a).

Circulations in the Hole

The 1987 Airborne Antarctic Ozone Experiment provided an excellent opportunity to examine, for the first time, the nature of the hole itself and its relation to the polar vortex. Both the ER-2 and the DC-8 made penetrations into the hole and recorded a variety of measurements both chemical and meteorological.

Unfortunately, as of this writing, the aircraft data were unavailable for detailed study. However, it was possible to look at the winds and advectations within the hole itself using the ECMWF charts. In Figure 31a the TOMS observations present the ozone hole as being clearly defined around the south pole. For the same date, the 70 mb streamlines and isotherms are presented in Figure 31b. The ozone hole is surprisingly dynamically active on its west (western hemisphere) side and dynamically inactive on its east side.

The western hemisphere clearly contains strong winds and pronounced positive and negative temperature advection. By contrast, the eastern half of the hole has extremely light winds and consequently, little temperature advection. The implications of the above observation is unclear at this time.

7.4 Dissolution of the Hole

Although the Antarctic ozone hole reaches maturity in early October, it usually does not dissipate until nearly a month later (in mid or late November). The ozone hole of 1987 was no exception. It retained its general shape and strong gradients until well into November. However, there are several stages in the dissolution of the hole that merit special attention.

Figure 32 presents four stages in the fading of the 1987 ozone hole. The hole reached its minimum value of 108 DU on October 5, 1987. It remained near this value for over two more weeks with much the same shape and areal extent. The hole as it appeared on October 22, 1987 is shown in Figure 32a. Just five days later, intrusions of ozone-rich air evidently began to erode the minimum total ozone region, until it appears as seen in Figure 32b for October 27, 1987. This erosion continued fairly rapidly since, on October 28, 1987--just one day later--the hole shrunk even more (Figure 32c). Finally, on the last day of October (Figure 32d), the hole appeared considerably smaller than it was just a week and a half earlier.

This sudden diminution would suggest a continued rapid dissolution of the hole. But this was not the case, for in the middle of November, the hole was not much less pronounced than at the beginning of the month.

ORIGINAL PAGE IS
OF POOR QUALITY

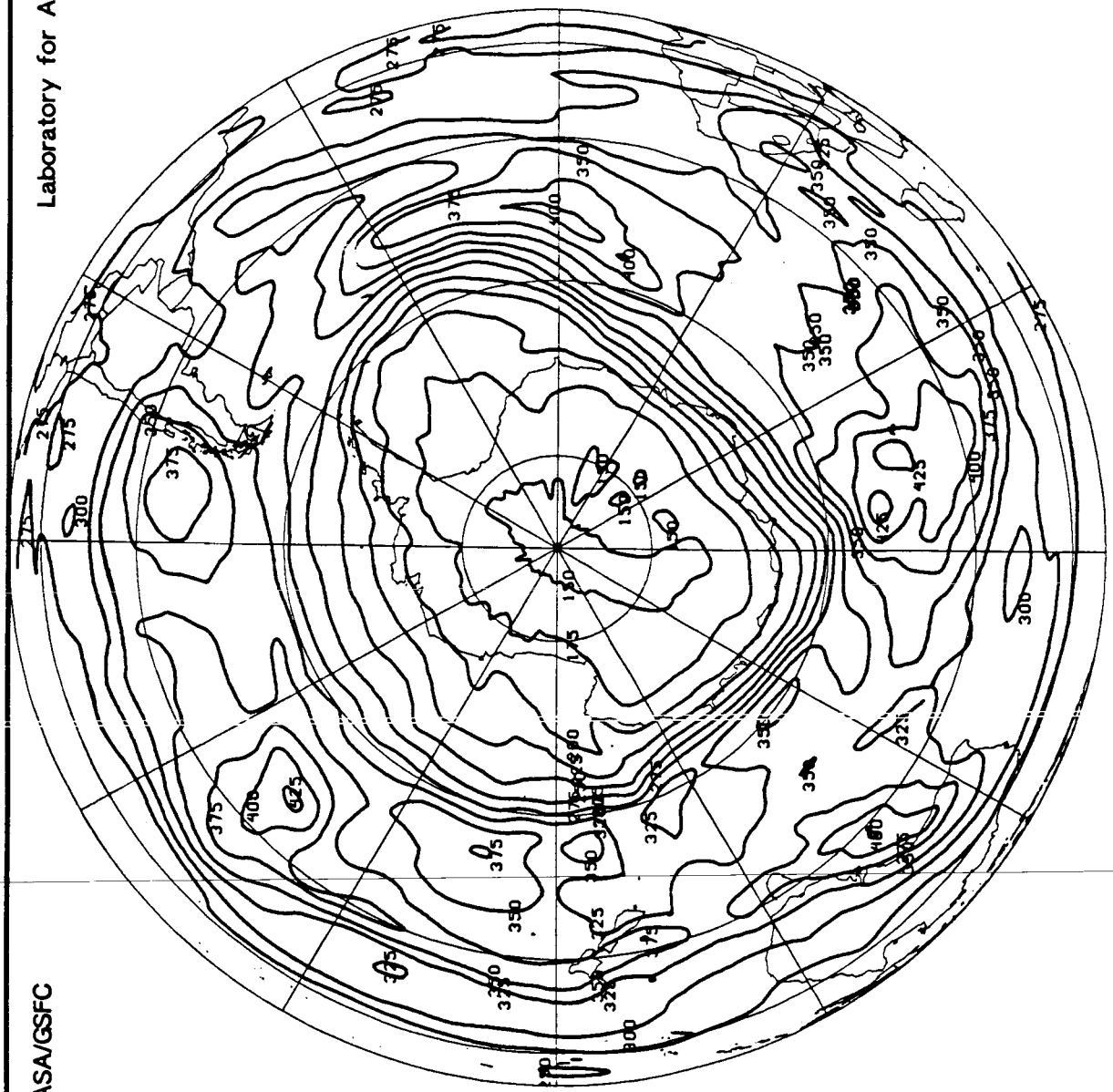

September 28, 1987

Gridded TMS Ozone (Dobson Units)

Figure 31a. TMS ozone distribution for the southern hemisphere on September 28, 1987.

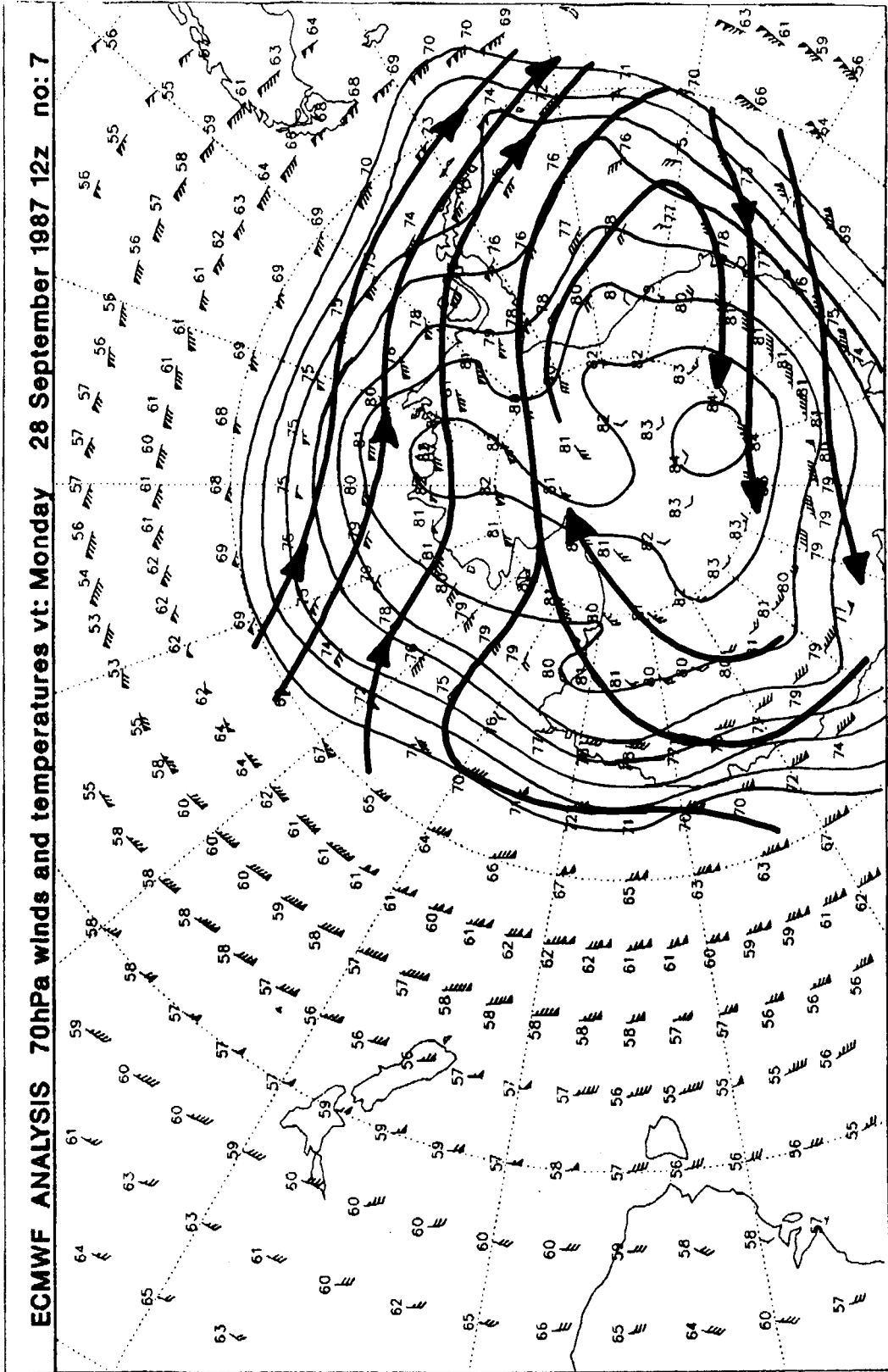

Figure 31b. ECMWF 70 mb analysis for September 28, 1987. Temperatures are in °C with minus signs omitted. Arrows indicate direction of the wind.

ORIGINAL PAGE IS
OF POOR QUALITY

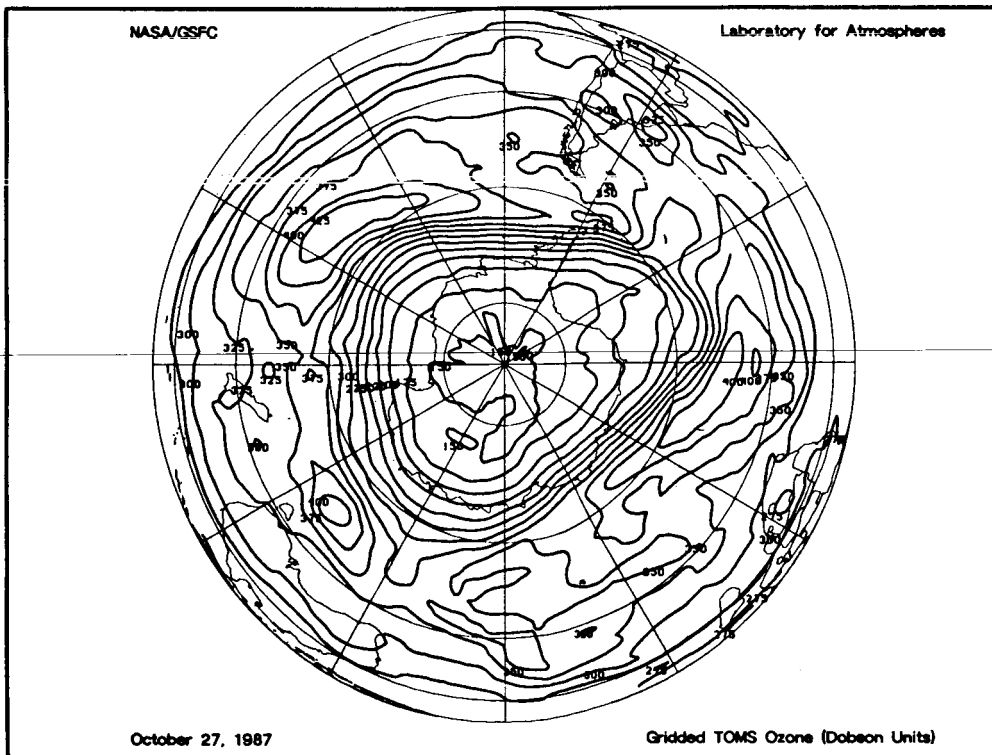
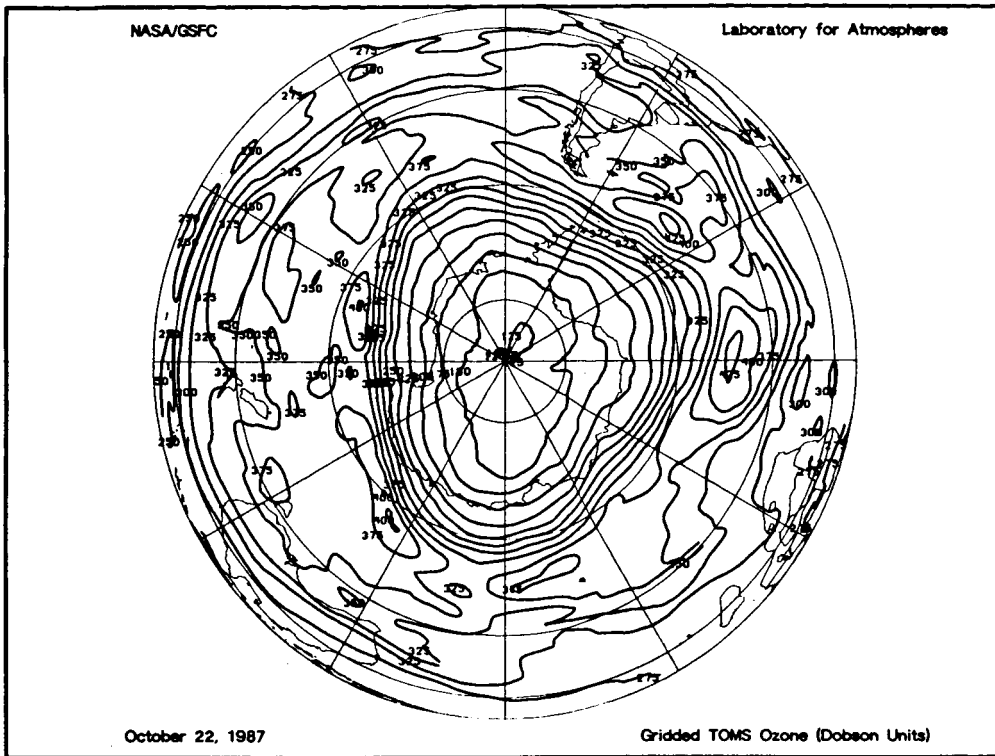

Figure 32a-b. TMS ozone distribution for the southern hemisphere on October 22 and 27, 1987.

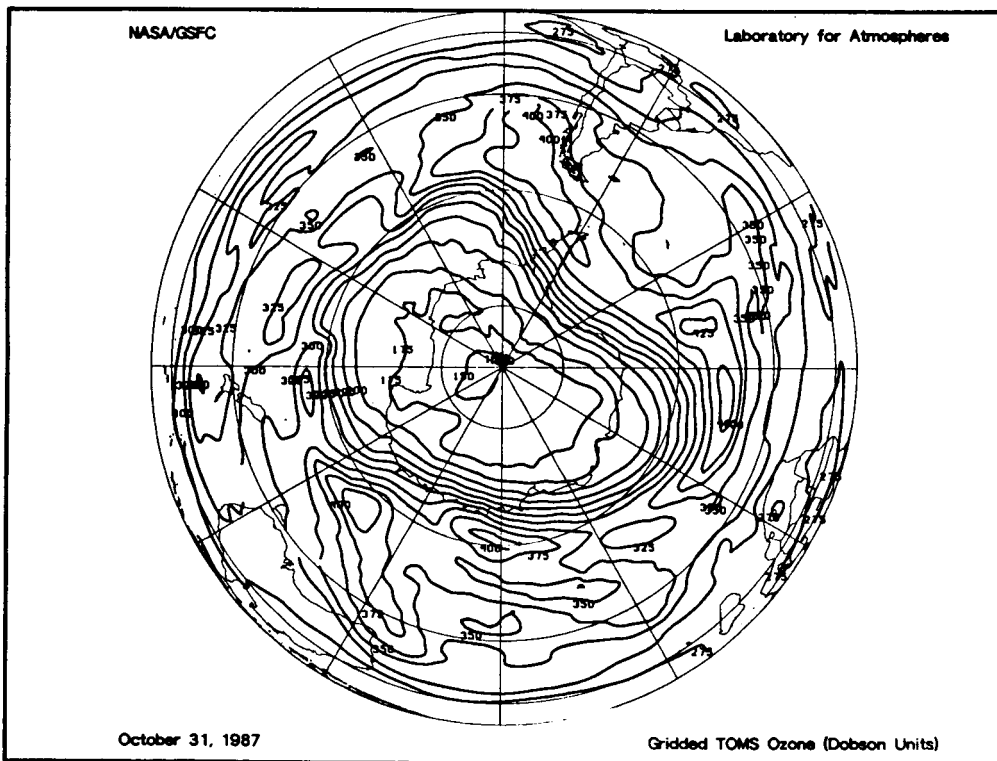
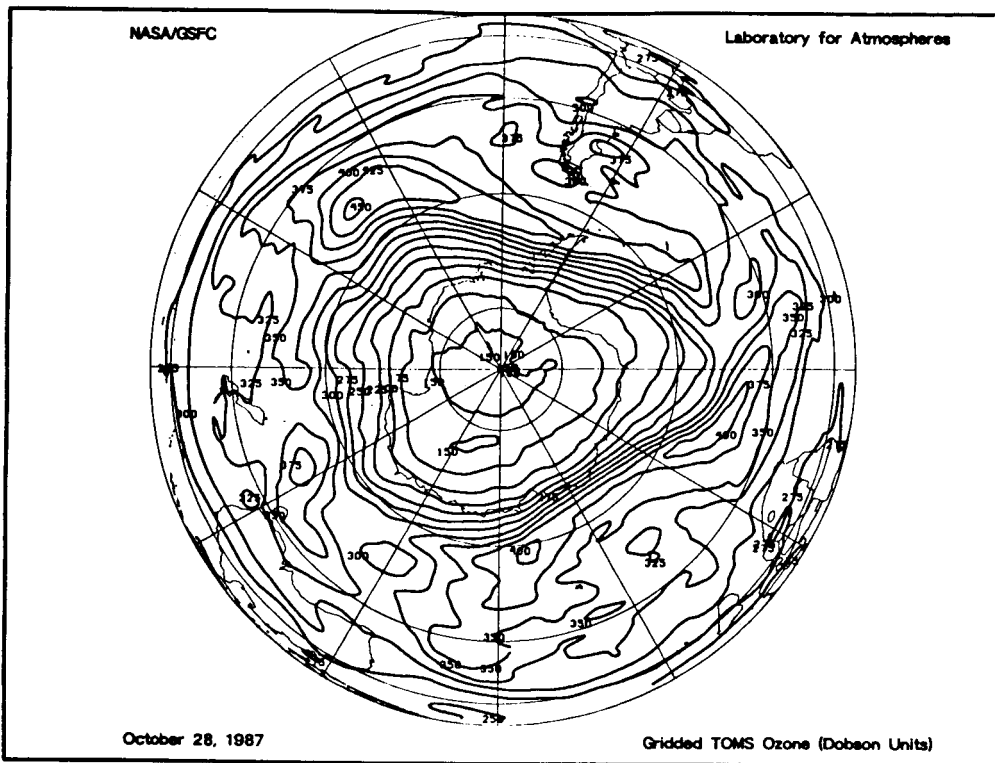

Figure 32c-d. TMS ozone distribution for the southern hemisphere on October 28 and 31, 1987.

8. CONCLUSIONS AND DISCUSSIONS

The Ozone Hole telecommunications were unique in several ways:

- the architecture was required to be very robust yet minimal in size and cost;
- data and fax were required to be available every day at specific times;
- information was required in near-real time;
- the time from the initial specification of the network requirements to operation was extremely short, and requirements were continually evolving;
- there was no existing communications base upon which to build;
- critical information was obtained from sources located on several continents.

The short time frame, coupled with changing requirements (not unusual in a project of this complexity) produced a number of problems and issues. It is important for further missions that the lessons learned be documented. Further, some of the difficulties encountered raise issues that should be addressed by NASA in order to simplify and accelerate such projects in the future.

8.1 Timely Requirements Definition

The communications network architecture, equipment, protocols, interfaces, and interconnectivity are all dependent on the users' requirements. It is not necessary, nor is it desirable, that scientists and flight management guess how many communications links are required, nor their characteristics. RDS was contracted to translate the requirements into network terms. However, since the network cannot be adequately defined without those requirements, it is imperative that they be listed, in as much detail as possible, at the very outset of the project and before engaging the communications contractor. Changes should be kept to a minimum. Since the complexity of the network cannot be gleaned from the requirements listing, an adequate lead time must be provided. In projects of comparable complexity to the 1987 Airborne Antarctic Ozone Experiment, where the mission go-ahead depends on a properly functioning and reliable network, six to seven months should ordinarily be allowed.

Certain pitfalls were encountered in this flagship project that can be avoided in the future. They are listed here with explanations of why they occurred. By understanding the rationale, it should be easy to recognize and avoid them in the future.

8.2 Understanding Lead Times

As in all fields, there are certain things that cannot be hurried; telecommunication carriers and equipment providers are among the worst. This is especially true when working with both domestic and international carriers. In this instance, we had three international carriers [MCI International (MCII), British Telecomm International (BTI) and Entel-Chile] and three domestic carriers [C&P in Maryland, BT in the UK and the Chilean Telephone Company (CTC)]. International carriers will promise nothing in under 60 days, to which one must usually add an additional month to cover the local exchange carrier (local telephone company). We were fortunate in that many of the key individuals were known to RDS.

Equipment providers are equally difficult, and one key device, the signalling kits, did not even make the 60 days one can usually expect for delivery. Multiple vendors, plus field modifications, were required to meet the project's go/no-go decision date.

Many small and medium-size vendors require a written purchase request before filling orders. Therefore, NASA should make a provision to release funds, or at least give purchase approval, as quickly as possible to the contractor in order to prevent additional delays. In this project, permission to order was obtained in pieces, i.e., approval to order telecommunications lines was given in early May, approval to lease equipment was given in mid-month, and purchase approval did not come until June. This usually contributes substantially to overruns in manhours and, therefore, cost.

The importance of lead time was felt acutely by the scientific staff, in that the Micro-VAX was not delivered until the end of July. This held up not only communications but also shortened the time for trouble-shooting--a necessity when bringing a new piece of equipment on-line. This impacted the Europeans as well as the Chilean contingent.

8.3 Dealing with Foreign Carriers

Unlike carriers in the States, foreign carriers are rarely faced with competition. Therefore, introduction of new ideas is usually a process that takes years. Such a situation arose in dealing with BTI. To make the telecommunications user-friendly and very reliable, RDS designed the network around two basic concepts: all participants would be off-premises extensions (OPX) of switches at GFSC, UKMO, and ECMWF; all communications links would be configured as analog facilities so that voice, fax, and data could be handled on any line. The importance of the first feature was that any office at GFSC, UKMO, or ECMWF could be reached by dialing two or five digits (easy numbers to remember); the second feature resulted in a maximum restoral capability for a minimum number of lines and, therefore, minimum cost.

Implementation of these concepts created a problem in that BTI had little or no experience providing OPX's over such long distance and they had not successfully employed CCITT V.32 modems over long distances. A personal visit and three days of face-to-face discussions with BTI personnel were required to convince them to implement our architecture. They did this reluctantly and installed new PBX's to isolate the existing facilities in the event of a failure.

This occasion points out the importance of choosing a contractor with experience in dealing with national and international organizations.

8.4 Equipment Interfaces

An area that is usually underestimated when one is required to complete a project in a short time is the problems that arise when a diverse set of equipment must be incorporated into an operating network. Although the individual components work according to specifications, this is no guarantee that the equipment will work as a system. The reason is that there are many interrelated parameters that must be juggled. It is not unlike an orchestra composed of fine musicians that requires the conductor to bring out the quality and cohesiveness of the group.

1. The criticality of the information involved required the near-instantaneous restoral of communications when a link degraded or was lost. To meet this demand, the digital data from the VAX machines had to be converted to an analog format for transmission over conditioned voice lines. The VAX machines were operating in an asynchronous mode and required full duplex operation (simultaneous two-way communication). The best modem available, however, was synchronous. Simply stated, the computers sent out information in bursts with no set timing between bursts. The modem expected to see a continuous stream of data. It was required, therefore, to interpose an additional piece of equipment between the computers and the communication modems. In asynchronous operation, the timing of the data bits is not critical because of the short burst nature of the communication. In a synchronous mode, timing is critical in that, if the modem clocks and computer clocks drift apart, communications between machines are lost. Therefore, it was essential that a single source for the network clock be established and that levels be adjusted properly. This situation required much adjustment before the full 9.6 kbps full-duplex operation could begin.
2. Operating at 9.6 kbps in a full-duplex mode (equivalent to 2 x 9.6 kbps) requires that the communication lines and all intervening equipment work at peak performance. Therefore, C&P (the local Maryland carrier), the GSFC Rolm CBX-9000 switch, MCII (the U.S. international carrier), Entel-Chile (the Chilean international carrier), and CTC (the Chilean

local carrier) had to be monitored and supervised to ensure the network would work. This coordination and supervision began shortly after the lines were ordered (early May), full-duplex operation at half the desired computer data rate was achieved by August 8th and full operation was realized by mid-August. This was too close to the critical dates. Adequate time must be allowed, since little control can be exercised over the organizations involved.

3. Three different facsimile machines were used for this project. The machines in the U.K. were those with which BTI was familiar and operated at 220 volts. The fax in Chile was rented from the Chilean Telephone Company to avoid the cost of purchasing, shipping and paying the local value-added taxes. No trouble was experienced except between GFSC and Punta Arenas. In this instance, the machine in Punta Arenas would answer the call from GSFC but would abort before the message was received. However, voice communication worked well. What we found was that the fax mode on the NEFAX 18 was very sensitive to level adjustment and had to be set first. Voice, being uncritical, worked at those settings. A contributing factor may have been that the noise level on the lines between GSFC and Punta Arenas was higher than that from Punta Arenas to GSFC. Whether this was a problem with the lines or the Rolm CBX-9000 was not investigated because of lack of time.
4. When putting in an international network, one must be aware of the signalling techniques between receivers in the different countries. When British Telecom International installed the special switchboards to accommodate our requirement for off-premises extensions, signalling between instruments was taken for granted. We had taken push button telephone instruments with us from GSFC and they worked between GSFC and Punta Arenas. However, between Punta Arenas and the U.K. there were problems. The problem was solved when it was found that the U.K. switchboards would only accept rotary-dial phones (with ground-start signalling). In the world of signalling there are at least six different methods accepted internationally. No problems should be experienced with telephone receivers working into the CBX-9000 at GFSC since this sophisticated switch should handle almost anything.
5. In restoral mode, the defective line is taken out of service for repair and information routed over the remaining ones. In this instance, the signalling units required to interface telephone instruments and switches had to be properly matched as well. This was difficult because different situations existed in the U.S. than in the U.K. or in Punta Arenas. At GSFC the switch was very sophisticated and fully software-controlled. At ECMWF and UKMO there were simple hardwired switchboards with some flexibility. In Punta Arenas there was no switch at all. In addition, two vendors' products

were used at the signalling interface. In the initial network architecture, it was assumed that signalling interfaces, regardless of vendor, were specified by the CCITT (International standards organization). It was not until all equipment were installed that it was found that the form of the interface between GSFC and the U.K. would not work for GSFC to Punta Arenas. Analysis of the hardware showed a fundamental difference in how the two vendors implemented their signalling units. It was necessary, therefore, to ask MCII to modify the units facing Punta Arenas in order to make the two circuits function properly. This was done over a weekend, thanks to some very dedicated engineers. However, this made it impossible to perform the simple reroute at the Punta Arenas NASA/RDS Communications Center patch panel. Instead it was necessary to perform a wire switch at the Entel-Chile board in their room at the Punta Arenas airport. Permission was obtained for us to have access to this equipment rack, something no carrier will usually permit.

8.5 Rolm CBX-9000

In the main, the Rolm CBX-9000 switch operated admirably. Its ability to handle analog and digital lines and different types of telephone dialing and signalling methods, automatically, solved many interface problems. Several anomalies, however, were noted. It is recommended that GSFC have these incidences checked out. A switch of this complexity could still have some obscure bugs in its software.

On the weekend of August 1st and 2nd, the push-button phones in Punta Arenas were not accepted by the CBX-9000. It was necessary to replace them with dial phones. On Monday, August 3rd, the problem went away. This was reported to GSFC at several levels as soon as was possible. It is not known if this was investigated and if any problem was found.

Although it is not possible to pin down specific incidents, many of the people who had called to or from GFSC over FTS lines reported the quality as only fair. Whether this is a switch problem or a general FTS problem was not investigated. Comments were not confined to the period of this experiment. Apparently this situation has persisted for some time.

8.6 Engineering Compromises

1. As noted previously, BTI installed special switchboards to accommodate the requirements for off-premises extensions. The necessary switchboards were very small since they were only needed to handle a few lines. It was decided to lease equipment that was not sophisticated and not software controlled. This made the lease price very low. It was found, however, that the switchboards could not be modified so that all lines came to the extension (telephone instrument) side (a situation necessary for our purposes). It was

decided that the line from GSFC would, therefore, come in on the line side (outside lines) of the switch at ECMWF. In this situation, dialing from GSFC automatically went to an operator for call completion. Since the critical information was TOVS/HIRS data for Dr. Cariolle's Centre Nationale de Recherches Météorologiques (CNRM) model, to be run on the ECMWF Cray X-MP/48, the data were called for by ECMWF when they were ready for it. Since dialing to the CBX-9000 was a matter of dialing two numbers, this was no inconvenience.

2. Original requirements stated that all communications from the military side of the air base in Punta Arenas would be with the civil side. Just before flights were to begin, it was decided that the experimenters required access outside Punta Arenas. Time did not permit rearrangement of circuits. To accommodate this requirement, all calls were received at the NASA/RDS Communications Center and manually patched to their final destination.
3. Because of the large number of personnel involved and the limitations on space at the Punta Arenas Airport, a facility was set up at the Cabo de Hornas Hotel. It was originally intended that this location be manned and all communications controlled and logged. To do this would have required additional personnel. It was decided, therefore, not to have a control at the hotel. Since the lines at the Cabo de Hornas were direct distance dialing (DDI) commercial lines, the cost per minute was very high. The experience gained by NASA on this experiment should give insight into whether it is more cost effective to have an individual, or at least some kind of control, at locations where DDI lines are available. At the very least, a log should be kept. It will act as a constraint on the number of calls an individual might make.

8.7 Manning Participating Sites Twenty-four Hours A Day

In a relatively complex project, there is always a myriad of equipment, locations, and competencies required to keep the project functioning properly. Where the chance to accumulate data has a restricted window, and/or real-time or near-real-time operation is required, and/or lines and/or expensive equipment are involved, the premise should be that all the expertise required should be available 24 hours a day, seven days a week. This should only be violated after a detailed analysis shows that there are alternative ways to accomplish the necessary coverage. In the case of the 1987 Airborne Antarctic Ozone Experiment, the following factors were present that dictated the need for full-time coverage:

- There was no other time possible within which to collect the ozone data (until possibly the following year);
- TOMS data were essential for the mission planning;

- Daily fax pictures were necessary so that decision makers could decide whether missions should be flown or not;
- Daily TOVS/HIRS data were required for the Cariolle model.

Translated into simple terms, both the mission and air crew safety depended on the computers, communications and, to some extent, delivery of tapes from NOAA/NESDIS. To provide adequate assurance that no one element would destroy the project, it is our opinion that all locations should have been covered full-time and an expert to cover critical software/hardware areas also available. This should not only include those facilities and expertise over which the key project officers have direct control, but arrangements should be made with managers responsible for other key elements as well. Commitments should be obtained at the very outset of the project. If necessary, the vendors should be made aware of the critical elements and asked to cooperate. Such was the case with MCII, Racal Milgo, Entel-Chile, and Coherent Systems.

8.8 Value of the Communications Patch Panel

A patch panel is a simple passive board where two ports can be easily connected by plugging a wire between them. The connectors in this instance are called jacks and the panel is commonly known as a jack panel. In Punta Arenas this patch panel was invaluable. It was installed between Entel-Chile's equipment and the project equipment. It performed the following functions:

- monitoring of all lines for performance;
- testing of circuits;
- rerouting of most lines in the event of a problem;
- patching calls to and from the military side of the air base in Punta Arenas to the outside world;
- allowing additional telephone instruments to be added to the existing network;
- allowed RDS to perform the above functions without touching Entel-Chile equipment.

8.9 Assigning Responsibility for Communications to the Contractor

The communications network for this project evolved into a complex system over a period of two months. Just how complex it would become was not visualized at the start of this contract. It was further complicated because it involved international organizations. Because of the evolving nature of the scientific and

aircraft requirements, coupled with several severe logistics problems brought on by the short time available to complete the network, decisions had to be made and carried out very quickly. It is imperative, therefore, that the contractor be given the authority to carry out the work without interference. It behooves the contractor, however, to keep the project personnel completely informed--preferably before action has to be taken.

One particular problem that must be avoided in the future is that of changing an oversight manager in mid-project. It is natural for anyone coming on board to want to come up to speed before important decisions and actions are taken. This can, however, be detrimental to the project. It is important, therefore, that there be a period of transition where the outgoing responsible officer remains to bring the new individual up to speed. It is good practice, where many equipments must be married to the communications network, to give the communications contractor responsibility for interfacing, installing and testing all such equipment. The fact that individual pieces work well does not ensure that they will work as a network. Contractor responsibility should extend to testing even before the network goes together. Further, it is good practice to give the contractor responsibility for crating and shipping the equipments to their final destination. This is the best way to be assured that the equipment will arrive in working condition. One final point: by assigning total responsibility to a single contractor no jurisdictional problems arise and there is no question as to who has responsibility to make the entire network perform. Too often, where several organizations have overlapping responsibilities, none are willing to take responsibility for things that go wrong.

8.10 Keeping Management Informed

One of the most important factors that contributes to a smooth running operation is keeping management at all levels informed of progress. This is especially important for high-visibility, costly projects and where several divisions and/or agencies are involved. There were several instances during the course of this project where lack of communications up the chain and across division lines resulted in confusion and delay. Funding was held up almost to the point where we were in jeopardy of missing the critical August 8th go/no-go date. In the case of the 1987 Airborne Antarctic Ozone Experiment, time was critical.

8.11 Timely Coordination

1. When dealing with agencies overseas there are always procedures that are not common to those in U.S. Agencies. It is important, especially in projects with a short time fuse, to begin negotiations on all details at the beginning of the project. The inclusion of Dr. Cariolle in the project was uncertain for many weeks. The importance of his input was not in question, but exactly how to get data to him and where the data would be processed became an issue. A visit by RDS

personnel was required in order to resolve how and where data would be received and processed. This resulted in a redesign of the communications in the United Kingdom. The link between ECMWF and UKMO was questionable until late July.

2. Another issue arose when it was finally decided to process the TOVS/HIRS data at ECMWF. Because of the need for daily, scheduled receipt of charts in Punta Arenas, personnel at ECMWF were required to work beyond their normal hours. NASA was requested to fund overtime but could not since it was not in NASA's charter to pay employees of a foreign agency. This caused delay and further added to uncertainty. It required special effort on the part of not only RDS but Peter Gray, the telecommunications and computer manager at ECMWF. Good computer-to-computer communications was not established until the first week of August, very close to the go/no-go decision date. It is recommended that NASA look into the situation of funding overseas agencies so that, when the situation arises, it could be handled expeditiously.
3. TOVS/HIRS data were required daily at a specific time by ECMWF. These data were generated by NOAA/NESDIS. However, there was no electronic way to get these data directly from NOAA/NESDIS to ECMWF. Late in the project, NASA/GSFC also decided to make use of the NOAA data. There was discussion within GSFC that physically transporting the data from NOAA to GSFC on magnetic tape was not in keeping with NASA's image, and that only an electronic means would be acceptable. Valuable time was spent by both RDS and GSFC personnel looking for an electronic route. Finally, however, "bicycling" was accepted because time was getting very short and it represented the best solution at the time. It is important that all requirements for data be stated at the very outset of a project. If this cannot be done, and circumstances do arise where additional requirements come up, there should be a designated individual whose decisions are final to mediate such matters as quickly as possible.

8.12 The Importance of Communications

There is a tendency in scientific experiments to concentrate on the science and allow other aspects to slide. In the 1987 Airborne Antarctic Ozone Experiment, communications, although not a scientific objective, should have been placed near the top of project priorities because it was on the critical path of the entire project. Lack of a good communications network could have aborted the entire experiment. That is not as true for any scientific instrument. The lack of TOMS data and poor quality of meteorological charts could have forced abandonment of the project.

It is not necessary for the scientists to be communicators in order to determine whether communications is a key to success.

The following five questions will determine just how important telecommunications is to the project:

1. What are the important data, voice, pictures/charts involved?
2. Are there a number of locations involved?
3. Is there a need to transfer the data, pictures/charts between the locations?
4. Are any of the elements required in real-time or near-real-time?
5. Is the transfer of information important enough to impact the scientific results in a critical/very important way?

If the answers to all five questions are positive, telecommunications should be considered a top priority. If the answers are yes to all but the fourth question, telecommunications should be considered a high priority.

8.13 Some Lessons Learned in Dealing with Smaller Nations

Projects to be carried out in developing countries always require a longer set-up time, usually measured in months. In addition, the interaction between project personnel and the local people involved is different than between scientific peers. Many situations arose in this project, some of which pointed up truths that are fairly universal in such environments.

1. If equipment, especially communications/computers or scientific instruments that are not recognized and understood are involved, it is best to get all of the required paperwork and clearances underway at the very outset of the project.
2. If there are people in the area who can order equipment locally or who can handle paperwork within the country, it pays off in reduced time and, in many instances, avoidance of value added tax (VAT).
3. If there are NASA installations in the country(ies) involved, even if not directly concerned with the specific project, get them to assist early on. They will know the local procedures and people and can usually speed things up. Further, they can be authorized as an agent to sign legal and shipping papers, etc. This speeds things up considerably. Also, the personnel are there to oversee progress and take action on delays.
4. The Embassy should be informed early on. They are always willing to be helpful and appreciate being involved in anything which can heighten their visibility.

5. NASA employees, and all project-involved personnel, should wear something that identifies them with the project. This makes the local personnel working with the project feel that they, too, are important. Productivity improves as a result.
6. Stickers, badges, and hand-out materials given to local merchants, people working on the project, results in a great deal of good will and cooperation.
7. The use of interpreters is always a sensitive subject. Most local personnel who work with the project will speak good-to-excellent English, or think they do. They are, to some extent, insulted if they are forced to communicate via an interpreter. They feel it is demeaning to have to deal through a third party. Further, more cooperation is achieved if a personal relationship is established between NASA and the local people involved.

It is a good idea to have several NASA personnel involved who speak the local language. In this way, it is not obvious that an interpreter is present, and shades of meaning are not missed or mistaken by the mission people.

Interpreters are very useful when dealing with local merchants, banks, money exchangers, etc. They can also point out where to go and what to avoid in the area.

9. REFERENCES

Austin, J., E. E. Remsberg, R. L. Jones, and A. F. Tuck, 1986: Polar stratospheric clouds inferred from satellite data, Geophys. Res. Lett., 13, 1256-1259.

Callis, L. B., and M. Natarajan, 1986: The Antarctic ozone minimum: Relationship to odd nitrogen, odd chlorine, the final warming and the 11-year solar cycle, J. Geophys. Res., 91, 10771-10796.

Chandra, S., and R. D. McPeters, 1986: Some observations on the role of planetary waves in determining the spring time ozone distribution in the Antarctic, Geophys. Res. Lett., 13, 1224-1227.

Crutzen, P. J., and F. Arnold, 1986: Nitric acid cloud formation in the cold Antarctic stratosphere: A major cause for the springtime "ozone hole," Nature, 324, 651-655.

Dave, J. V., and C. L. Mateer, 1967: A preliminary study on the possibility of estimating total atmospheric ozone from satellite measurements, J. Atmos. Sci., 24, 414.

desJardins, M. L. and R. A. Petersen, 1985: GEMPAK: A meteorological system for research and education. Preprints, First International Conference on Interactive Information and Processing Systems for Meteorology, Oceanography, and Hydrology. Amer. Meteor. Soc., Los Angeles, CA, 313-319.

European Centre for Medium-range Weather Forecasting (ECMWF), 1987: Antarctic Ozone Project Final Report, November 2, 1987, 12.

Farman, J. C., B. G. Gardiner, and J. D. Shanklin, 1985: Large losses of total ozone in Antarctica reveal seasonal ClO_x/NO interaction, Nature, 315, 207-210.

Fleig, A. J., K. F. Klenk, P. K. Bhartia, and D. Gordon, 1982: User's guide for the Total-Ozone Mapping Spectrometer (TOMS) instrument first-year ozone-T data set, NASA Ref. Publ. 1096.

Heath, D., A. J. Krueger, and H. Park, 1978: The Solar Backscatter Ultraviolet (SBUV) and Total Ozone Mapping Spectrometer (TOMS) experiment, in The Nimbus-7 User's Guide, edited by C. R. Madrid, pp. 175-211, NASA Goddard Space Flight Center, Greenbelt, Md.

Klenk, K. F., P. K. Bhartia, A. J. Fleig, V. G. Kaveeshwar, R. D. McPeters, and P. M. Smith, 1982: Total ozone determination from the Backscattered Ultraviolet (BUV) experiment, J. Appl. Meteorol., 21, 1672-1684.

Koch, S. E., M. desJardins, and P. J. Kocin, 1983: An interactive Barnes objective map analysis scheme for use with satellite and conventional data, J. Clim. Appl. Meteor., 22, 1487-1503.

Krueger, A. J., M. R. Schoeberl, and R. S. Stolarski, 1987: TOMS observations of total ozone in the 1986 Antarctic spring, Geophys. Res. Lett., 14, 527-530.

Mateer, C. L., D. F. Heath, and A. J. Krueger, 1971: Estimation of total ozone from satellite measurements of backscattered ultraviolet earth radiances, J. Atmos. Sci., 28, 1307-1311.

McCormick, M. P., and C. R. Trepte, 1986: SAM II measurements of Antarctic PSC's and aerosols, Geophys. Res. Lett., 13, 1276-1279.

NASA/ARC, 1987: Airborne Antarctic Ozone Experiment Project Office MS 245-5, July 1987, 50 pp.

Newman, P. A., and M. R. Schoeberl, 1986: October Antarctic temperature and total ozone trends from 1979-1985, Geophys. Res. Lett., 13, 1206-1209.

Nimbus Observation Processing System, 1986: Nimbus-7 Solar Backscattered Ultraviolet and Total Ozone Mapping Spectrometer (SBUV/TOMS), GRIDTOMS Tape Specification #T634436, 1-17.

Panofsky, H. A., 1968: Introduction to Dynamic Meteorology, College of Earth and Mineral Industries, the Pennsylvania State University.

Schoeberl, M. R., and A. J. Krueger, 1986: The morphology of Antarctic total ozone as seen by TOMS, Geophys. Res. Lett., 13, 1217-1220.

Sekiguchi, Y., 1986: Antarctic ozone change correlated to the stratospheric temperature field, Geophys. Res. Lett., 13, 1202-1205.

Solomon, S., R. R. Garcia, F. S. Rowland, and D. Wuebbles, 1986: On the depletion of Antarctic ozone, Nature, 321, 755-758.

Stolarski, R. S., A. J. Krueger, M. R. Schoeberl, R. D. McPeters, P. A. Newman, and J. C. Alpert, 1986: Nimbus-7 SBUV/TOMS measurements of the spring time Antarctic ozone hole, Nature, 322, 808-811.

Toon, O. B., P. Hamill, R. P. Turco, and J. Pinto, 1986: Condensation of HNO₃ and HCl in the winter polar stratospheres, Geophys. Res. Lett., 13, 1284-1287.

ACKNOWLEDGEMENTS

The Nimbus-7 TOMS total ozone data were reliably and regularly supplied to the Airborne Antarctic Ozone Experiment operations office in Punta Arenas. The quality, timeliness, and dependability of the near-real-time and delayed TOMS data sets permitted the TOMS total ozone observations to play a crucial role in the planning and successful completion of the aircraft flights. Without question, the reliable provision of the orbital and hemispheric TOMS observations played a central role in the outstanding success of the mission. The authors, and the RDS team, were provided assistance by many individuals and many organizations during the course of the experiment. Without this help, the TOMS total ozone data could not have been delivered in a punctual manner, and indeed, the experiment may not have been possible. While it is not possible to name every individual who played a role, certain acknowledgements must be made.

We are grateful for the good advice, active participation, help and guidance provided by the Assistant Technical Representatives (ATR's). Dr. R. Hudson, Head of the GSFC Atmospheric Chemistry and Dynamics Branch, was the ATR on science issues. Sol Broder, Head of the Advanced Data Flow Technology Office, was the ATR on communications issues. Dr. A. Krueger, as general ATR and co-Chairman of the SBUV/TOMS Instrument Team, was instrumental in the smooth operation of the project and provided much-needed support and guidance. We wish to thank Arnie Oakes of NASA/GSFC, in his capacity as the Contracting Officer's Technical Representative on the Nimbus Project, for helping to put together this uniquely qualified group of individuals that made the mission work.

The authors would like to express their appreciation to John Sissala, Mike Doline, and other members of the GE/RCA Service group for scheduling the data transfer from the Nimbus-7 satellite passes so as to obtain the telemetry in the quickest possible manner and for providing predictions of the Nimbus-7 orbital overpasses well in advance of the experiment. We also wish to thank Fred Shaffer, Hal Domchick, Herb Durbeck, and Scott Brittain of NASA/GSFC and the RMS Associates operations group for the smooth and continuous operations of the NSESCC during the experiment, and for adjusting the system maintenance schedule and job priorities to ensure the most rapid throughput of the TOMS data production on the IBM 3081. Also to be recognized are Robert Gray, Jerry Morrison, Damodar Goel, and Kirk Jones of STX who processed the raw TOMS data on the GSFC IBM 3081. The authors wish to thank the RDS telecommunications team, composed of James Victorine, Segun Park, Nasser Alizadeh, Susan Krupa, and Steven Gaines, who manned the communications center in Punta Arenas 24 hours a day, 7 days a week, and received the TOMS total ozone data. Recognition is due to Al Feiner and Woody Wheat of RDS who designed the real-time telecommunications network and monitored its installation and testing. We wish to thank Jorge Montero and Ramon Lopez of the DGAC in Punta Arenas, Chile who provided a comfortable work environment and whose hospitality will be

difficult to repay. We are also appreciative of Mary DesJardins of NASA/GSFC and Brian Doty and Ira Graffman of RDS for their timely modification of the GEMPAK software to permit its use in a southern hemisphere polar projection. Charles Cosner and Jerome Bennett, of the GSFC Space Data and Communications Division (Code 630), were very helpful in troubleshooting and setting up the DECnet network. We are also grateful to Brenda Vallette for the technical editing and assembly of this manuscript. Reginald Galimore and Scott Doiron, of Science Applications Research, were of considerable assistance throughout the project in a wide range of areas.



Report Documentation Page

1. Report No. NASA CR-4133		2. Government Accession No.		3. Recipient's Catalog No.	
4. Title and Subtitle Final Report on the Near-Real-Time TOMS, Telecommunications, and Meteorological Support for the 1987 Airborne Antarctic Ozone Experiment			5. Report Date April 1988		
			6. Performing Organization Code 616.0		
7. Author(s) P. Ardanuy, J. Victorine, F. Sechrist, A. Feiner, L. Penn, and the RDS Airborne Antarctic Ozone Experiment Team			8. Performing Organization Report No. 88-44		
			10. Work Unit No.		
9. Performing Organization Name and Address Research and Data Systems Corporation Greenbelt, Maryland 20771			11. Contract or Grant No. NAS5-29373		
			13. Type of Report and Period Covered Contractor Report		
12. Sponsoring Agency Name and Address National Aeronautics and Space Administration Washington, D.C. 20546-0001			14. Sponsoring Agency Code		
			15. Supplementary Notes		
16. Abstract The goal of the 1987 Airborne Antarctic Ozone Experiment was to improve the understanding of the mechanisms involved in the formation of the Antarctic ozone hole. Total ozone data taken by the Nimbus-7 Total Ozone Mapping Spectrometer (TOMS) played a central role in the successful outcome of the experiment. During the experiment, the near-real-time TOMS total ozone observations were supplied within hours of real time to the operations center in Punta Arenas, Chile. This final report summarizes the role which Research and Data Systems (RDS) Corporation played in the support of the Experiment. RDS provided telecommunications to support the science and operations efforts for the Airborne Antarctic Ozone Experiment, and supplied near real-time weather information to ensure flight and crew safety; designed and installed the telecommunications network to link NASA-GSFC, the United Kingdom Meteorological Office (UKMO), Palmer Station, the European Center for Medium-Range Weather Forecasts (ECMWF) to the operation at Punta Arenas; engineered and installed Earth stations and other "stand-alone" systems to collect data from designated low-orbiting polar satellites and beacons; provided analyses of Nimbus-7 TOMS data and backup data products to Punta Arenas; operated and maintained GEMPAK/GEMPLT software at GSFC and Punta Arenas; and provided synoptic meteorological data analysis and reduction.					
17. Key Words (Suggested by Author(s)) Airborne Antarctic Ozone Experiment, Total Ozone, Field Experiment, Total Ozone Mapping Spectrometer (TOMS), Telecommunications Network			18. Distribution Statement Unclassified - Unlimited Subject Category 47		
19. Security Classif. (of this report) Unclassified		20. Security Classif. (of this page) Unclassified		21. No. of pages 134	22. Price A07