

NASA Technical Memorandum 100870

NASA-TM-100870 19880014445

A Cyclic Ground Test of an Ion Auxiliary Propulsion System: Description and Operational Considerations

Jerri S. Ling and Edward H. Kramer
Lewis Research Center
Cleveland, Ohio

RECEIVED
JUL 1 8 1988

JUL 1 8 1988

LANGLEY RESEARCH CENTER
HAMPTON, VIRGINIA

June 1988

NASA

A CYCLIC GROUND TEST OF AN ION AUXILIARY PROPULSION SYSTEM:

DESCRIPTION AND OPERATIONAL CONSIDERATIONS

Jerri S. Ling and Edward H. Kramer
National Aeronautics and Space Administration
Lewis Research Center
Cleveland, Ohio 44135

SUMMARY

The Ion Auxiliary Propulsion System (IAPS) experiment is designed for launch on an Air Force Space Test Program satellite (NASA TM-78859 (AIAA Paper No. 78-647)). The primary objective of the experiment is to flight qualify the 8-cm mercury ion thruster system for stationkeeping applications. Secondary objectives are measuring the interactions between operating ion thruster systems and host spacecraft, and confirming the design performance of the thruster systems. Two complete 8-cm mercury ion thruster subsystems will be flown. One of these will be operated for 2557 on/off cycles and 7057 hr at full thrust.

Tests are currently underway in support of the IAPS flight experiment. In this testing an IAPS thruster is being operated through a series of startup/run/shut-down cycles which simulate thruster operation during the planned flight experiment.

A test facility description and operational considerations of this testing using an engineering model 8-cm thruster (S/N 905) is the subject of this paper. Final results of this test will be published at a later date when the ground test is concluded.

INTRODUCTION

No prior cyclic ground tests have been performed on the IAPS thruster but the need for long cyclic life has been a major focus of the entire 8-cm thruster development program. In 1977 an 8-cm engineering model thruster, the immediate predecessor to the IAPS thruster, was tested for 5200 on/off cycles and 1300 operating hours using high voltage pulsed ignition of the keepers (ref. 2). In 1976 a 15 000-hr, 460-cycle test of an 8-cm prototype thruster using an auxiliary electrode for cathode ignition was completed (ref. 3). The results of the extended SERT-II flight (ref. 4) indicate that the duration of a mission should not affect the cyclic life of an ion thruster (provided that sufficient propellant is available), however, each new design still must be verified to assure flight performance.

The principal objectives of the cyclic ground test are: (1) to characterize the performance of the IAPS thruster over long term, cyclic operation, (2) to identify and quantify any thruster degradation processes which are potentially life limiting and which may require corrective or compensating actions in the IAPS flight test, and (3) to develop a data base for use in planning IAPS mission operations and interpreting IAPS flight data.

E-3251

N88-23829 #

No criteria have been established for the ultimate termination of the test (which began May 18, 1982), but operation until accumulated hours and cycles reach flight values is planned.

LIST OF SYMBOLS

ac	alternating current
ACCI	accelerator current
ACCV	accelerator voltage
CIV	cathode/isolator/vaporizer assembly
CRT	cathode ray tube
DAC	digital-to-analog converter
dc	direct current
DCIU	digital control and interface unit
DHTI	discharge heater tip current (cathode)
DI	discharge current
DKI	discharge keeper current
DKV	discharge keeper voltage
DVI	discharge vaporizer current
DVT	discharge vaporizer temperature
GN ₂	nitrogen gas
Hg	mercury
H ₂ O	water
I _a	accelerator current
IAPS	Ion Auxiliary Propulsion System
JNV	neutralizer vaporizer current
LN ₂	liquid nitrogen
Mo	molybdenum
NHTI	neutralizer tip heater current

NIV neutralizer/isolator/vaporizer assembly
 NKI neutralizer keeper current
 NKV neutralizer keeper voltage
 NVI neutralizer vaporizer current
 NVT neutralizer vaporizer temperature
 PEU power electronics unit
 PTVFU propellant tank/valve/feed unit
 RTD resistance thermal device
 SD shutdown
 Si silicon
 S/N905 8-cm engineering model thruster discussed in this report
 SV screen voltage
 TGBSU thruster/gimbal/beam shield unit
 TNV neutralizer vaporizer temperature
 Vg floating point potential
 VNK neutralizer keeper voltage
 Vscr screen supply voltage
 V δ difference voltage (DV - DKV)

EXPERIMENT DESCRIPTION

The thruster being tested is an 8-cm engineering model thruster (S/N 905) which has been upgraded to flight specifications. It was manufactured by the same personnel as the flight thrusters. Before and during installation every effort was made to preserve its "as manufactured" condition. It has only one known anomaly. The neutralizer vaporizer has significantly lower flow at all temperatures than the flight thrusters.

Power for operating the thruster is provided by laboratory-type supplies. Significant dynamic characteristics of the flight PEU are simulated. Primary data for the test is obtained from an in-line data monitor connected to the electrical leads between the thruster and its power supplies. The data is displayed locally, continuously plotted on chart recorders, and sent to a central computing facility for additional processing.

A specially constructed digital controller handles the overall operation of the thruster and the test. This eliminates the possibility of human error and assures reproducibility from cycle to cycle. During each cycle the thruster is started, operated at full beam for 2 hr 53 min, cooled down for 3 hr 20 min, and then restarted. A startup to full beam takes approximately 30 min. The startup algorithms used duplicate the "normal" path of the flight control algorithms. They do not however, have the extensive fault correction capability provided by the flight hardware.

Test Facility

This section provides a detailed examination of the ground test facility, including the vacuum chamber, mercury feed system, data system, and the thruster power supplies and controls.

An overall block diagram of the ground test facility is given in figure 1. The main vacuum facility is an 0.89-m (35-in.) diameter by 1.96 m (77 in.) high vertical chamber. It is equipped with a 0.31-m (12-in.) bell jar for isolation of the thruster. Pumping of noncondensable gases is provided by a 0.91-m (36-in.) oil diffusion pump. An LN₂ cooled, frozen mercury target and tray provide pumping of condensable gases and ensure that most of the material back-sputtered to the thruster by the primary ion beam is mercury. Additional pumping is provided by an LN₂ cooled cold wall. Typical beam on pressure is 1.3×10^{-4} Pa (1×10^{-6} torr).

The thermal, vacuum, and particulate environment experienced by the thruster must be controlled to adequately simulate operation on a spacecraft. The key word here is adequate since, of necessity, any ground-based test facility differs significantly from deep space. After a description of the test facility, these differences will be examined and their impact on thruster operation assessed.

Figure 2 is a sketch of the main vacuum chamber and its associated equipment. Pumping of noncondensable gases is provided by a single oil diffusion pump operated with silicone (DC704) pump fluid. The pump is equipped with a water cooled cold cap and a LN₂ cooled Chevron baffle to minimize backstreaming of pump oil into the main chamber. If the diffusion pump foreline pressure becomes unacceptably high, one of two standby pumps is automatically started and brought on-line.

A 30.5-cm (12-in.) diameter stainless steel bell jar is above the main chamber. The bell jar can be isolated from the chamber by a 0.31-m (12-in.) vacuum gate valve. The test thruster is mounted from a push-pull rod which extends through the top flange of this bell jar. Additional guides internal to the bell jar are used to orient and center the thruster. During normal operation the thruster is extended through the vacuum gate valve. In the event of difficulty with the vacuum system the thruster is manually retracted into the bell jar and, if necessary, the bell jar is filled with argon.

As shown in figure 2, the thruster beam is directed into a frozen mercury target through an annular tray which is also filled with frozen mercury. Thus the major portion of the material back-sputtered by beam ions is mercury. Target and tray are cooled with LN₂. Bulk temperatures are maintained in the

range of 160 to 173 K, the target warming slightly during beam-on periods. To minimize LN₂ consumption, an on/off control system based on vent gas temperature is used.

Cryopumping of mercury vapor and other condensables is provided by the target and tray, and an additional cold wall located around the outer circumference of the target and tray. The cold wall is made from perforated metal to allow adequate conductance to the entrance of the diffusion pump cold trap for the removal of noncondensable gases. Chamber pressure is sensitive to cold wall temperature which is controlled at approximately 200 K.

The target, tray, and cold wall are all constructed of stainless steel. The geometrical arrangement of the target and tray assume that there is no direct line-of-sight path between the inlet to the diffusion pump cold trap and the thruster. This further reduces the possibility that the thruster will be contaminated by pump oil.

The chamber is equipped with a number of access ports. Three of these are used for view ports. Two small 6.033-cm (2.375 in.) windows are available for inspection of the target and tray. One 12.07-cm (4.75-in.) window allows inspection and photography of the grid area of the extended thruster. An additional port is available for insertion of probes and a light source for photographic purposes, the internal tank lighting being inadequate for high resolution photography.

The vacuum system controls provide for unattended operation; startups and normal shutdowns of the facility are performed manually. Annunciators are used to indicate vacuum system status. An event recorder logs changes in system status and limit violations. Strip charts record main chamber and foreline pressures and multipoint recorders log important system temperatures. The number of events which can trigger a shutdown has been minimized. When a shutdown is initiated, argon is slowly introduced into the main chamber, in order to protect sensitive thruster surfaces by exposing them first to an inert gas, before other contaminants arrive.

The vacuum facility is equipped with three ion gages of the Bayard-Alpert type. The ion gage locations are denoted by V1, V2, and V3 in figure 2. V1 is located on the side of the upper bell jar and most closely indicates conditions at the thruster. V2 views the area immediately above the frozen mercury target, the cold wall on the opposite side of the tank, and the warm tank wall through the perforations in the cold wall. V3 is located near the top of the main chamber slightly above the level of the thruster grids. V2 and V3 are mounted to short sections of 5.1 cm (2 in.) tube equipped with vacuum gate valves and can be replaced with minimum perturbation to vacuum system operation. V1 can be replaced after retracting the thruster and isolating the upper bell jar. Overpressure limit sensing on two of the ion gages provides protection for the thruster. If the indicated pressure exceeds 2×10^{-3} Pa (1.5×10^{-5} torr) main power to the thruster controller is interrupted.

Vacuum chamber performance. - Typical beam-on and background pressures are given in table I. Beam-on pressure, corrected assuming 100 percent mercury vapor, is typically about 6.7×10^{-5} Pa (5×10^{-7} torr). This pressure has been quite stable, varying only slightly with room temperature and other operating conditions.

Considerable care was exercised to control outgassing in the vacuum chamber. The use of organic materials was minimized and, in areas which might be subject to heating, only Teflon and Kapton were used. Mercury feed lines are polyethylene but these remain at about 25 °C. Most of the surface area is stainless steel, mercury, and aluminum. Thus it is probable that, during normal operation, the major background gasses will be N₂, O₂, H₂O from the leak, and mercury and carbon sputtered or evaporated from warm surfaces. The water and mercury will be rapidly pumped by the cryosurfaces.

Anomalies. - The main chamber has a small, known leak in the weld joining the upper flange to the body of the chamber. External attempts at repair have been unsuccessful. Rewelding of the flange would require complete disassembly of the system. As acceptable background pressures can be obtained in the presence of the leak, the decision has been made to operate in spite of it. However, the leak does provide a continual source of contaminants from the atmosphere to the vacuum system. Unfortunately it is located close to ion gage V3 and produces the typical pulsed pattern on the V3 pressure trace. This limits the usefulness of V3 for background pressure measurements. Another small leak, located in the argon bleed system, was discovered and repaired during modifications to that system made in January 1983. At the time the thruster had accumulated 1442 hr and 570 cycles. As can be seen from table III, repair of this leak caused a major improvement in background pressure with V1 indicating pressure dropping almost an order of magnitude.

Background pressure with the thruster off tends to be unstable. V1 readings from 2×10^{-6} Pa (1.5×10^{-8} torr) to 9.3×10^{-6} Pa (7×10^{-8} torr) have been observed since repair of the argon system leak. V2 has ranged from 6.7×10^{-6} Pa (5×10^{-8} torr) to 1.3×10^{-5} Pa (1×10^{-7} torr).

Thruster mount. - Figure 3 shows the test thruster mounted to its support system prior to installation in the upper bell jar. The gimbal mounting tube on the thruster is mated to a split aluminum block. Clamps attached to the block and the regular gimbal mount screws are used to secure the thruster. The entire thruster mount is electrically isolated by shielded insulators located between the sides of the mount and, as seen in the photograph, the lower plate attached to the push-pull rod. The rectangular aluminum bar on the left in the photo extends to the tip of the beam shield. It protects the thruster from gross damage should an attempt be made to extend it through a closed vacuum gate valve. The bar runs along Teflon guides inside the upper bell jar to orient and stabilize the thruster. Electrical leads and mercury lines loop around the push-pull rod and penetrate the top flange of the upper bell jar. The thruster mounting block is instrumented with thermocouples. The mount temperature does not vary greatly during normal cyclic operation. The highest temperature recorded, during continuous 50 hr beam-on run, was 52 °C. The lowest recorded temperature, after 2 weeks of cold soak, was 6 °C.

Figure 10 presents a schematic diagram of the ground test mercury feed system. The drawing indicates the relative vertical position of the various components. All components of the feed system which are in contact with mercury are made from stainless steel, glass, or polyethylene. All valves in contact with the propellant are stainless steel, zero displacement rotary plug valves with Buna-N seals. Zero displacement valves were used to preclude the possibility of damaging or intruding the thruster vaporizers through excessive pressure as the valves are operated. To allow retraction of the thruster and

tilting of the upper bell jar, portions of the system are made from 0.25-in. polyethylene tubing (Imperial Eastman 44-N3R). A nitrogen atmosphere at 3.5×10^4 Pa (5.1 psig) is maintained on top of the mercury to prevent oxidation and contamination, and to provide a suitable operating pressure at the vaporizers.

Before the system was filled with mercury it was completely disassembled (including all valves and fittings), ultrasonically cleaned, flushed with alcohol and then distilled water, dried, and reassembled. The reservoir was then filled with ultra-high-purity, triple-distilled mercury. Examination of figure 10 shows a group of three valves in each mercury line which are located at the point where the lines penetrate the vacuum system. The lines to the thruster were valved off and those portions of the system outside of the vacuum chamber were evacuated. The external system was then filled with mercury from the reservoir. Vacuum was then applied to the purge ports and a sufficient quantity of clean mercury was withdrawn from the system to completely flush all lines. This was done to remove any trapped gas or particulate matter which might have remained in the system.

The lines internal to the vacuum system and the thruster were filled with mercury in a manner which simulates planned flight operations. Immediately following installation, the test thruster was held at a hard vacuum for more than 2 weeks. The propellant lines internal to the vacuum chamber and the thruster were pumped out through the porous tungsten plugs in the thruster vaporizers. Just prior to thruster start-up, the downstream valves in the propellant lines were opened and the lines inside the vacuum tank and thruster allowed to fill with mercury.

Power Supply System and Electronics

The power supply and control system must provide to the thruster a reasonable simulation of the significant electrical characteristics of the flight PEU/DCIU. In accomplishing this function it provides electrical power conditioned to the voltage and current levels required by the current operational state of the thruster. It provides closed loop analog control of the neutralizer and discharge vaporizer heaters, based on the neutralizer keeper voltage and discharge chamber difference voltage respectively. Quasi-digital control of the beam current is also provided along with a flight-equivalent recycle sequence for the control of high-voltage arcing. In addition, the dynamic electrical impedance presented to all plasma discharges is simulated and flight-type signal conditioning is provided for the vaporizer resistance temperature detectors (RTDs). This section examines in detail, the power supply system used for the ground test.

Power supplies and interconnection. - Figure 4 shows the interconnection of the various elements of the power supply system. The interconnection of the thruster power supplies duplicates that of the flight PEU with one exception: here the screen supply (V_{scr}) is connected to the thruster engine body (cathode common) while in the flight PEU a mag-amp type current sensor is located in the lead connecting the junction of the anode and screen supplies to cathode common. This sensor provides feedback for control of the discharge supply current. As a result of this difference, in the ground test anode current is

regulated, while in flight, emission current of the discharge supply is controlled. During operation there is no difference between the two schemes as long as no beam current is being extracted. It should be noted that the ground test discharge current includes the screen current, while the flight test does not. In the beam-on state, the discharge current is varied to control the beam current as is done for flight. Because of the feedback, the true discharge current during beam-on run should be identical to flight. The effect of this difference should only be seen as a small perturbation to the beam-on transition.

Table I lists the significant characteristics of both the ground test power supplies and those in the flight PEU. The supplies used in the ground test have linear, dissipative regulators (transistors or vacuum tubes while those in the flight PEU are slower switching mode regulators.

Impedance compensation networks. - It is known that the dynamic impedance which the neutralizer and discharge keeper supplies present to their associated plasma discharges has significant effects on thruster operation. To provide proper operation for flight, chokes of known inductance and resistance have been added to the leads of both keepers.

For the ground test the discharge impedance control networks shown in figure 6 have been added to both keeper supplies and the discharge supply. For the keeper supplies these networks duplicate the resistance and inductance of the chokes in the PEU. They also duplicate the output capacitor and shunt resistor of the flight keeper supply. For the discharge supply the impedance control network duplicates the inductance and resistance of the flight output filter choke and the capacity of the flight output capacitor.

Recycle control. - The recycle sequence for the screen, accelerator, and discharge supplies, following detection of an overcurrent condition, closely simulates that used for flight. The overcurrent detection techniques do not. Figure 7 is a block diagram showing, among other items, the overcurrent detection and recycle control circuitry used for the ground test. It also shows the beam current control technique which will be discussed in another section.

In the flight PEU a recycle sequence is initiated by the overcurrent protection circuitry in the screen supply only. The accelerator supply is current limited at approximately 8.0 mA and during overcurrent conditions the output voltage rapidly decreases. The flight screen supply has an overcurrent limit value of about 85 mA. The time constant of this circuit is on the order of 50 μ sec. Current from the 0.47 μ fd power supply output filter capacitor does not flow through the overcurrent sensing circuit, so that it is insensitive to short (less than 5 μ sec) transients.

Controller Description

Overall control of the ground test is provided by two sequential digital controllers which operate asynchronously. One controls the discharge cathode and main discharge startup and the beam-on transition. The other handles neutralizer startup and the duration of the beam-on run period. Because even this "simplified" controller is quite complex, a detailed description of the ground test controller, its programming, and a comparison of thruster operation using

the ground test controller versus the flight controller is provided in the text which follows. Only a brief overview will be given here.

Conceptual block diagrams of the two controllers are given in figures 5(a) and (b). The details of their programming are given by tables IV and V. As the two controllers are very similar and, for the most part, use identical hardware they will be described together.

The heart of each controller is its diode matrix memory with associated address decoding and address register. The address register selects one of the states programmed into the memory. The neutralizer/run controller has 16 possible states; the discharge controller 17, an additional state being added to accommodate changes in programming.

Each controller provides a number of states. In each state the status of all thruster parameters being controlled is specified. Each state also has specific conditions for its termination and initiates another state or states. State transitions can be initiated after selected time intervals or by the occurrence of a specified condition in a thruster parameter. At each state transition, a data scan is recorded or logged, if so programmed. A programmable flag bit for each controller allows synchronization of the two controllers when required.

Programming of the controllers is by two diode matrices, each of which contains approximately 340 diodes. This method was chosen over more conventional forms of read-only memory because of its flexibility. Any individual bit can be changed quickly using only a soldering iron. In a more complex controller such a method would be impractical.

The various fields in the diode matrix memory can be divided into two groups. In one group are fields which completely specify the status of the thruster power supplies. In the other group are fields which control the address register associated with the diode matrix. Each controller also has a flag for communicating with the other. At any time, one discharge controller state and one neutralizer/run controller state is always active.

In the thruster control group the vaporizer control fields provide (1) an off state, (2) four fixed vaporizer current setpoints, (3) a temperature control mode, and (4) an automatic control mode.

The tip heater and keeper fields each allow six fixed current settings or setpoints and off. The ignitor fields only provide on/off control. The discharge current field in the discharge controller allows the selection of off, and two fixed currents. The high-voltage control field provides on/off control for the screen and accelerator supplies.

The thruster control states are sequenced by the transition control logic. Each transition between states allows 3.5 sec for recording the end-of-state data. In either controller a state transition may be initiated by any of four sources: (1) the shutdown line from the other controller, (2) the shutdown trigger select logic, (3) the jump trigger select logic, and (4) the increment trigger select logic. These are prioritized in the order given. Potential trigger sources are selected by the associated fields in the diode matrix. Trigger inputs are derived from comparators measuring the needed thruster

parameters, timers internal to the controllers, and the flag field of the other controller. One trigger input of each type is wired "false" to provide an off mode.

The selected trigger inputs are sampled once every 2 sec. If one or more of these inputs is "true" one of the various types of state transitions is initiated. During a transition, sequential data record and data print commands are first sent to the data system if they have been enabled by the appropriate fields in the diode matrix. While not shown on the conceptual block diagram, a "true" shutdown input always causes the data system to both record and print data. At this point selected timers are also latched into a cleared condition and held there.

After the 3.5-sec delay to allow the data system to complete its operations, the controller acquires the required new state. In a shutdown the address registers in both controllers are cleared to zero. If a jump is to occur, the contents of the jump address field are loaded into the address register. An increment input causes the address register to increment one count. Jump and increment inputs during state 15 of the discharge controller are exceptions. In that state, either of these causes a separate flip-flop to be set which selects state 16. Clear inputs to the timers are released at this time.

There are effectively three timers associated with the discharge controller and two associated with the neutralizer/run controller. All timers count synchronously by the 0.5 Hz clock. After a state transition the first count of 2 sec will occur 0.5 sec after the clear input is released, effectively shortening the transition time to 2 sec from a timing point of view. The timers provide 1 percent accuracy.

With two exceptions, all time intervals ordinarily required for operation are obtained from one timer in each controller. The run time interval to the neutralizer/run controller is one exception. It is derived from the regular discharge controller timer. In this way the run time is accurately synchronized with the full-beam transition, (state 15 to state 16) of the discharge controller. The off interval is the other exception. It is held in a cleared state unless the discharge controller is in state zero, the off state. When it times out it initiates the beginning of preheat low, the zero-one state transition, for both controllers. The shutdown timer in each controller has one fixed time interval. Each has a separate control field in the diode matrix. The shutdown timers are used to terminate unsuccessful operating sequences. From a hardware point of view they in no way differ from the other timers.

Beam current control. - Figure 7 also illustrates the beam current control technique used. During automatic beam current control modes the discharge current reference signal is derived from a digital to analog converter (DAC). An 8-bit binary up/down counter provides the digital input for the DAC. If the thruster screen supply current is below the low limit, the counter is placed in the countup mode and the discharge current is increased by 7 mA every 10 sec. If the screen supply current is above the high limit the counter is placed in the countdown mode and the discharge current is decreased in the same manner. If the screen current is between the limits the counter does not increment.

Additional circuitry, not illustrated in the figure, presets the counter to a discharge current value which corresponds to the previous fixed setpoint value prior to the beam-on transition. It also inhibits counting during the recycle sequence so that a long series of recycles will not perturb the discharge current operating point. There also exist a number of fixed discharge current setpoints used during thruster startup. All discharge current programming inputs go through slow rate limiting circuitry to prevent abrupt changes.

This beam current control technique is equivalent to that used in flight during the establishment of the thruster beam. There is a discharge current step of about 6 mA every 5 sec until full beam is reached. The ramp rate for the ground test and the flight are very similar. During beam-on operation, the flight system samples the screen supply current once every 10 sec and changes the discharge current by 6 mA (up or down) if it is found to be out of range.

For the ground test upper and lower limits of 73 and 71 mA were initially chosen. However, the circuit has shown a certain tendency to allow the beam current to drift up with time and temperature and so has been readjusted periodically to keep the operating beam current reasonably close to 72 mA. The flight system used limits of 73 and 70 mA.

Difference voltage controller. - Figure 8 provides a block diagram of the ground test discharge chamber difference voltage (anode voltage minus keeper voltage, V_6) controller. It controls discharge chamber propellant flow rate by varying the power (current) to the discharge vaporizer heater. As can be seen from the block diagram it is composed of three parallel control paths. The top path actually controls V_6 . The other two paths prevent operation in a flooded condition by limiting the maximum vaporizer temperature and overall loop gain (thruster gain is normally negative). The outputs of the three paths are combined so that the one requiring the lowest vaporizer power dominates. An absolute minimum power level is also established. An absolute maximum power (at 2.5 A) is established by the discharge heater power supply.

The difference voltage is obtained by direct measurement through a commercial isolation amplifier. The V_6 loop is normally the only active loop. The transfer function of the V_6 loop, other than dc gain, simulates that used for flight.

The flight system uses an intricate software routine to control potential "flooding" of the discharge chamber with mercury propellant. For the ground test a system was designed which monitors the thruster gain and controls it at a level which is sufficiently negative to allow undisturbed operation. To accomplish this the discharge vaporizer current is continuously perturbed by a pseudo-random binary sequence with zero average value. The sequence of perturbations repeats every 264 sec. The shortest time interval between perturbations is 4 sec, the longest is 16 sec. There are 32 perturbations before the sequence repeats. The pseudo-random sequence was chosen to prevent possible correlations with other system sequences and possible resonant excitation of latent instabilities. The peak-to-peak amplitude of the perturbation is approximately 0.2 A above and below the approximately 1.5 A of normal beam-on discharge vaporizer heater current. In the fully stabilized state the perturbations are completely compensated for by the V_6 control loop in about 3 sec. While the thruster is warming up after the beam-on transition, the V_6 control

loop has only a minimal effect on the longest perturbation intervals. The perturbation only produces a noticeable effect on accelerator current (± 2.5 percent) and on discharge voltage (± 1 percent).

The V6 feedback signal is applied to the gain loop through a lead network (essentially a differentiator). This network serves to remove the dc component, to limit the effects of fast transients, and to minimize instabilities. The loop, however, is not necessarily stable. The output of the lead network is clipped and fed to the phase detector. This detector is sensitive to both amplitude and phase, the sign of the output reversing as input phase reverses. The output of the phase detector is compared with a reference signal and applied to a very long time constant, high gain integrator. Five to ten perturbations are required following a phase reversal for the output to become active. Once active it overshoots considerably, usually allowing the V6 loop to regain control on the recovery.

Neutralizer keeper voltage controller. - The neutralizer keeper voltage (VNK) controller is similar to the V6 controller as can be seen from the block diagram (fig. 9). It has two parallel paths, one for VNK and one for neutralizer vaporizer temperature (TNV). The outputs of the two paths are combined so that the one calling for the lowest neutralizer vaporizer heater power (current) dominates. The temperature control loop was added because the neutralizer of the flight thruster has the potential for flooding due to excessive mercury flow. Practically, the ground test thruster neutralizer vaporizer has a relatively low flow transmissivity, and hence requires a higher than normal TNV for a given neutralizer mass flow rate. It has proven extremely difficult to "flood" the neutralizer partially because of this.

The VNK feedback signal is obtained by direct measurement through a differential amplifier. (The entire controller is referenced to vaporizer potential, not neutralizer potential). The first time constant shown in the block diagram arises from the filter used to protect the input to this amplifier. The remaining portion of the loop transfer function duplicates that used in the flight system with the exception of dc gain. The gain was adjusted to produce a mildly underdamped response. During operation, in the absence of externally induced transients, both VNK and the vaporizer current (JNV) are completely stable.

The temperature loop serves to prevent operation of the neutralizer vaporizer at temperatures exceeding its setpoint, thereby limiting mercury flow through the neutralizer vaporizer. The temperature loop has relatively low gain and slow response. Not shown in the block diagram is circuitry which disables the temperature loop and drives its output to full-on in the event the neutralizer keeper voltage rises excessively. High neutralizer keeper voltage could result in extinguishment of the neutralizer, because it usually is the result of low mass flow through the neutralizer. There are no indications from the strip chart data that, the neutralizer vaporizer temperature loop has ever been active during the operation of the ground test.

Ground Test Controller Software

The ground test is controlled by two coupled finite state devices with supporting electronics. One finite state device controls the discharge chamber

and the screen and accelerator supplies. The other controls the neutralizer and the duration of the beam-on run period. Operation of the two is synchronized where required.

The programming of the controllers simulates the significant features of the flight control algorithms for normal thruster startup and full beam operation. "Hard start" and other fault correction routines have been replaced by simple shutdowns. Deliberate variations have been introduced into the controller programming to compensate for certain deviations of the test thruster properties from those of a standard flight thruster.

In programming the ground test controllers the basic assumption was made that the thruster would run normally. It was assumed that the various discharges would immediately light under the programmed ignition conditions, that flooding of the discharge chamber and neutralizer would not be major problems, that discharges once ignited would stay lit, that the beam could be established easily, and that operation during beam-on would be stable. The effort was made to duplicate the path that the flight algorithms would take under these assumptions. However, thruster abnormalities are in general not accommodated or corrected in the ground test programming, as many are in the flight test algorithms. Detection of any such abnormality in the ground test normally forces a thruster shutdown.

Controller software summary. - The controllers provide a good approximation to the "normal" flight startup algorithm. At the beginning of the startup period current is applied to the neutralizer vaporizer and tip heaters in two steps to minimize thermal shock. After ignition (of the keeper) the tip heater power is reduced to its run value and the vaporizer heater current is operated at a reduced fixed level for 3 min. During this time the vaporizer temperature falls and the keeper voltage rises. At this point the neutralizer keeper voltage control loop is enabled. The controller reduces vaporizer heater current to a lower value, further reducing vaporizer temperature (and flow) until the keeper voltage rises to its setpoint value, typically about 14.75 V. With respect to the thruster neutralizer these conditions remain unchanged for the remainder of the startup and ensuing run periods.

Provided the neutralizer operates successfully under automatic control, the controller sets a flag allowing the discharge controller to begin the beam-on transition sequence, once ignition of the discharge cathode and main discharge are completed. Discharge ignition begins with keeper ignition, and is similar to neutralizer keeper ignition, except the preheat phase stops at a lower temperature. Following vaporizer temperature control the low voltage keeper supply is turned on. Following keeper ignition the tip heater power is held at its ignition value for 10 sec, reduced to a lower value and held for 20 sec, and finally reduced to its run value.

After the discharge keeper is lit, the discharge supply is turned on. Then the controller enters the warm-up phase which lasts for 5 min. Next, the discharge current is reduced and automatic control of the discharge vaporizer via the difference voltage control loop is established. This state lasts for a minimum of 5 min and then the discharge controller begins checking that stable neutralizer operation has been achieved.

The controller then enters the 5 min "pre-beam" state in which discharge keeper current is increased and discharge vaporizer temperature is controlled. This is followed by the beam-on transition in which discharge current is cut back and screen (SV) and accelerator (ACCV) voltages are applied using the standard recycle sequence. Then both discharge mass flow rate and beam current are placed under automatic control. The extraction of ions from the discharge chamber causes a step increase in discharge voltage with resultant transients in vaporizer current and temperature. The beam current controller causes the discharge current to ramp up at a constant rate until full beam current, nominally 72 mA, is reached. Soon after the beam current exceeds 68 mA the controller enters the full beam run state which reduces discharge keeper current and causes the neutralizer/run controller to begin timing the beam-on run period. Once full beam is reached, conditions are maintained until shutdown sequence is initiated.

A flowchart of the discharge controller programming is given in figure 13. When interpreting these flowcharts it should be remembered that the controllers are finite state devices, not sequential digital computers. The rectangular state blocks and the immediately following decision diamonds are all part of one state-of-the-finite-state device. The effective order of the decision blocks is established by priority logic. Decision conditions are only sampled once every 2 sec. The conditions established by a given state block remain in effect until another state block is entered. For details of conditions during any given state see table V.

Transitions to SD (shutdown) are caused by all shutdowns of the discharge and neutralizer/run controllers. SD leads to the off state which lasts for 12 600 sec (3 hr, 30 min). This time was chosen as a compromise. It is intended to allow the thruster to cool down to within 30 °C of its equilibrium temperature in order to simulate the thermal stresses of flight. (The thruster actually cools to about 25 °C in each cycle. It is impractical to lengthen the "off time" enough to significantly reduce this temperature because then the total calendar time to conduct this 2500-cycle test would become extremely long.)

Detailed software description/comparison. - The discharge controller then enters state 1 which corresponds to the beginning of the flight discharge keeper ignition sequence. A slightly lower discharge vaporizer current is used (1.27 versus 1.76 A) and the state lasts for 10 sec instead of the 8 sec used for flight. This state applies low power to the discharge vaporizer and tip heaters to avoid thermally shocking them when the full preheat power is applied in the following state, state 2. This state brings the discharge vaporizer and cathode to near operating temperatures and helps condition the cathode for starting. This state can last for up to 13 min, 20 sec but is normally terminated by the discharge vaporizer temperature reaching 275 °C. Operation is identical to the corresponding portion of the flight sequence.

Next comes state 3, a temperature control state to allow the cathode-isolator-vaporizer (CIV) assembly to stabilize and to further condition the cathode for starting. For the ground test a hardware implementation of the temperature control function is used. The temperature control loop is essentially in the flight software.

If the keeper fails to light on the low voltage supply the discharge controller proceeds to state 5. In this state the ignitor supply is turned on and left on for 10 sec. In the flight algorithms the ignitor is on for 5 sec maximum and ignition is tested every second. The ground test controller then proceeds to state 6, which is an ignition check lasting a maximum of 10 sec. If the keeper is not lit or does not remain lit the controller returns to the pre-ignition vaporizer temperature control, state 3, prior to another ignition attempt. In the ground test discharge controller the temperature control periods always last for 180 sec. In the flight algorithms the periods are reduced to 60 sec after the first attempt at ignition.

If the keeper remains lit the discharge controller proceeds to state 7 in which a tip heat reduction to an intermediate level occurs. If the keeper goes out the controller returns to state 3 to prepare for another attempt at ignition. If the keeper remains lit for 18 sec, the controller proceeds to state 8. In this state the tip heat is reduced to the normal operating level and held there for another 18 sec. If it goes out the controller returns to state 3 for another pass through the ignition sequence.

In the flight software the number of unsuccessful ignition attempts is limited to six. The hard start routine is then called. This routine causes a thruster shutdown unless it is able to light the keeper. In the ground test discharge controller, a similar function is served by the shutdown (SD) timer. It starts timing before state 3 is entered and allows 650 sec, enough time for three full attempts at ignition, for state 8 to be completed. Otherwise the thruster is shut down. If the keeper goes out during state 8 the shutdown timer is cleared before returning to state 3 for three more attempts at successful ignition.

Entry into state 9 of the discharge controller corresponds to entry into the flight discharge ignition algorithm. In state 9 the discharge supply is turned on. If the main discharge lights an immediate transition is made to state 11. If the discharge fails to light within 10 sec the controller proceeds to state 10 where the discharge supply is turned off for 4 sec before a return to state 9 for another attempt to light. The shutdown timer allows this cycle to continue for 650 sec (47 cycles) before shutting the thruster down.

If the main discharge lights, the controller jumps to state 11. This state provides 300 sec of thruster warmup at high discharge current with the discharge vaporizer remaining temperature-controlled as described above. This reproduces the flight algorithms exactly.

The controller then proceeds to state 12 and initiates closed-loop discharge vaporizer control based on a reference value of 25 V for the difference voltage (DV - DKV). This state is maintained for 300 sec. If the discharge extinguishes during this time, the extinction is sensed and the thruster is shut down. The equivalent process to state 12 in the flight algorithms uses the anti-flood routine for a variable time followed by 60 sec of operation under closed-loop control. In the ground test the hardware of the difference voltage controller contains anti-flood circuitry to perform the same function (fig. 8). The flight algorithms use a difference voltage setpoint of 25.9 V at this stage while the ground test controller has only one fixed point of 25 V. (This may give a slightly different discharge flow rate.) When state 12 times

out the controller proceeds to state 13, a discharge maintenance mode with continued closed-loop vaporizer control, to wait for the neutralizer controller flag indicating that the neutralizer has been started and stabilized. An equivalent process takes place at the end of the flight discharge ignition algorithm.

When the neutralizer flag is set the discharge controller advances to state 14. This is the pre-beam condition with high discharge keeper current and with vaporizer control based on the sensed discharge vaporizer temperature. Its purpose is to stabilize the discharge chamber near the point required during beam-on. The flight control algorithms have an identical state immediately after entry into the beam-on routine. However, for flight, the state only lasts 180 sec. The ground test pre-beam period was extended to 300 sec to hold the peak value of discharge voltage within reasonable bounds at beam turn-on.

At the end of the pre-beam the discharge controller enters state 15. Here the screen and accelerator supplies are turned on, the discharge vaporizer is under closed-loop control at the difference voltage setpoint of 25 V, the discharge current is under automatic control with a beam current setpoint of 72 mA, and the discharge keeper current is reduced to 120 mA. In the ground test a long time constant on the control inputs to the discharge keeper supply aids in keeping the keeper discharge lit during this process. The discharge current initially starts at 410 mA and is ramped up by the controller at a rate of 7 mA every 11 sec. The flight algorithms apply the high voltages and ramp up the beam current in a similar but more detailed way, which includes calling the discharge anti-flooding procedure.

The ground test controller transitions to state 16, the run state, when the beam current reaches 62 mA or when the timer reaches 300 sec. In the ground test run state, as in the flight algorithms, the discharge keeper current is reduced to 68 mA, the discharge vaporizer is maintained under closed-loop difference voltage control, discharge current is adjusted to maintain a 72 mA beam, and the beam-on flag is set. Unless the beam current falls below 34 mA causing a shutdown, the discharge controller will remain in this state indefinitely. The neutralizer/run controller generates a shutdown after the run time expires to terminate the cycle.

Starting at point SD the neutralizer/run controller enters state 0, the off state. It remains there for 12 600 sec until the "off timer," located in the discharge controller, causes both controllers to enter state 1 simultaneously. Entry into state 1 of the neutralizer controller corresponds to entry into the flight neutralizer startup algorithm. State 1 is a 10 sec turn-on of the neutralizer vaporizer and tip heater to intermediate setpoints before the full preheat/conditioning setpoints of state 2 are applied. As with the discharge cathode this procedure minimizes the possibility of damage to the heaters due to thermal shock.

The controller then enters state 2, the neutralizer preheat/conditioning phase, which brings the neutralizer/isolator/vaporizer (NIV) assembly near operating temperature. The vaporizer current and tip heater current setpoints used are identical to flight. The controller remains in state 2 until the neutralizer vaporizer temperature reaches 370 °C or the timer reaches 16 min (960 sec). The corresponding values for the flight algorithm are 355 °C and

980 sec. The higher temperature is used for the ground test because of a significantly lower neutralizer vaporizer flow characteristic for the test thruster as compared to the flight thrusters.

When the required vaporizer temperature is reached or the timer times out, the controller enters state 3. This is equivalent to the software temperature control mode used in the flight algorithm but, it is implemented via the controller hardware. Because of vaporizer flow differences a temperature control range from 370 to 380 °C is used as opposed to the 350 to 365 °C range used for flight. This still results in a somewhat reduced propellant flowrate at ignition than the optimal 24 mA which the flight setpoints are designed to provide.

After 180 sec of vaporizer temperature control, state 4 is entered. This is equivalent to entry into the flight ignition sequence. In state 4 the low voltage neutralizer keeper supply is on with the current setpoint at 530 mA. If the keeper lights, as detected by the keeper current exceeding 100 mA, the controller jumps to state 7. If it fails to light within 10 sec, the controller proceeds to state 5 where the keeper ignitor is turned on. Again, if ignition occurs a jump is made to state 7. State 7 is a repetitive ignition check at full starting tip heat that lasts for 10 sec. If the keeper fails to light during the 10 sec of ignitor application in state 5 or goes out during state 7, the controller goes to state 6 for 62 sec of vaporizer temperature control in preparation for another try at ignition.

The controller programming is equivalent to the flight algorithm except that the low voltage keeper supply is on alone for 10 sec instead of one, the ignitor is on for 10 sec instead of 5, the ignition check lasts for 10 sec instead of 5 and, if the ignition check fails, no attempt is made to restart immediately. After six failed attempts at ignition, the flight algorithm proceeds to the hard start routine. If this routine is successful, the neutralizer ignition sequence proceeds; if not, the thruster is shut down. In the ground test the shutdown timer limits the number of attempts to 17 before a shutdown occurs.

If the ignition attempt is successful and the keeper discharge remains lit through the ignition test of state 7, the controller proceeds to state 8. In this state the tip heat and vaporizer power are reduced and operated at lower fixed setpoints for 180 sec, which is analogous to the flight algorithm. The controller then proceeds to state 9 where closed-loop control of the neutralizer vaporizer is established and maintained with the reference keeper voltage set at 15.25 V. State 10 is merely a continuation of state 9. The flight algorithms differ from this procedure in that they call an anti-flooding routine to assure that the neutralizer discharge is not flooded when the closed-loop vaporizer operation is initiated. In the ground test, neutralizer flooding is controlled through the use of temperature limits in the vaporizer controller hardware. If the neutralizer extinguishes during state 8 or 9 the controller will return to state 6 and begin a new attempt at ignition, the total number of such attempts being limited by the shutdown timer. The shutdown timer is cleared and reset to 1390 sec on exit from state 10. If the neutralizer goes out during this state the controller returns to state 6 and the full ignition algorithm is reinitiated from this point. The flight software limits the number of neutralizer extinctions to three.

The transition from state 10 to state 11 is equivalent to exiting from the flight neutralizer ignition routine. The neutralizer ignition flag is set on entering state 11. In all of the following states, if the neutralizer extinguishes the thruster will be shut down and no attempt will be made to restart the neutralizer. States 11 and 12 together form a wait state with the neutralizer operating normally under closed-loop vaporizer control. The discharge controller remains in discharge maintenance (state 13) until it finds the neutralizer flag set during one of these two states. It then initiates pre-beam (state 14). The neutralizer controller will remain in the state 10-state 11 loop until the discharge flag is set or until 1380 sec have elapsed. The discharge flag is set when the thruster beam is established and the discharge controller enters the run state (state 16). State 12 checks the 1380 sec shutdown timer and so provides a 23 min limit on the time available to the discharge controller to establish the beam.

State 13 is entered when the discharge controller enters state 16, the beam-on run state. Its only purpose is to record an early data point 5 min after the beam is established. State 14 is the beam-on run state. It is terminated by the 10 800 sec (3 hr) run timer in the discharge controller. This timer is started when that controller enters the beam-on run state. State 15 causes an immediate shutdown of the thruster after first taking a final beam-on data point. In this way both controllers are returned to the off state (state 0), and a new cycle begins.

Data System

The overall system block diagram (fig. 1) shows the chief components of the data system and their relationship to the rest of the system. With the exception of the vaporizer temperatures, all thruster data is obtained from a single set of sensors located in the thruster leads close to the vacuum system penetrations. From this point the data takes three separate paths: a local digital display allows a quick review of thruster status; strip charts continuously record selected parameters; and a centralized data system reads all parameters every second and logs and stores the data on a mainframe computer for later processing. This section defines the parameters measured and describes the data system in detail.

System description. - Figure 11 defines the thruster parameters measured by the data system. The sensors (high-voltage isolation amplifiers and magnetic current sensors) are located in the leads to the thruster. Because of the layout constraints, about 3.1 m (10 ft) of lead wire intervenes between the sensors and the thruster. No separate potential leads are used, but lead resistance has been controlled to minimize any effect on the accuracy of voltage measurements. For the thruster cathode and vaporizer heaters, the calculated lead resistance is less than 5 percent of the heater resistance at operating temperatures. For other thruster voltages lead drop is negligible.

Sensors are calibrated to better than 1 percent of full scale. In general, the measurements used duplicate those for the flight PEU (with some additions). However, discharge anode current is measured instead of cathode emission current, and true beam current rather than screen supply current is measured. In addition, all supplies are equipped with analog panel meters at the power supply package.

For tracking long-term performance, the thruster and facility data are recorded on the NASA Lewis Research Center central data system (ref. 24). In general, under normal operating conditions, the resolution is on the order of 0.1 percent. Table II provides a listing of the input channels to the central data system and shows both full-scale input voltage and its equivalent in engineering units. As can be seen from the table, in addition to thruster data, tank pressure, target temperature, and controller status are also recorded. The data system computes beam-on hours (based on beam current) and counts cycles (by following controller status). This information is recorded with the other data. Once in the data system the information is either converted to engineering units and printed locally for logging purposes or transferred to the central computing facility for future processing.

The recording and routing of data is governed by the ground test controller. Data is recorded and/or logged at the end of the off period, at the end of a number of long duration states during the startup, at beam-on, 5 min after beam-on, and at the end of the beam-on run period. The special points in the thruster cycle at which data is recorded and/or printed locally are indicated on the flow charts and programming sheets in figures 13 and 14. In total, 11 data scans are printed and 19 are stored each cycle. Data is also recorded and logged anytime the thruster is shut down by the controller. The intent is to obtain data at well defined points in each operating cycle so that meaningful long-term trends can be discerned. The sequence of status numbers recorded with the data allows the determination of which state the thruster was in when the data was taken and the detection of anomalous or unsuccessful startups.

The data system also provides a display of all data in engineering units on a CRT. This display is updated approximately once each second. However, since it is located in a control room, it is not visible from the facility. To provide easy access to data for local control and fast analysis of thruster condition, digital displays of all thruster data to full accuracy are provided at the test site.

Sixteen of the thruster parameters (except the heater voltages) are continuously recorded on two analog strip chart recorders. These recorders respond to signals with frequencies up to 125 Hz.

The chart recorders provide a continuous record of all thruster operation. Their speed of response assures that no significant thruster events will be missed. The very slow chart speed used, 3 mm/min, has both advantages and disadvantages. Because of the slow speed it is impossible to resolve the time sequence of events which occur within 5 to 10 sec of each other. However, the slow speed places an entire operational cycle on a relatively short piece of chart paper which can be rapidly scanned to detect serious deviations from the norm.

Typical Cycle

Figures 12(a) and (b) provide typical strip chart data from a cycle early in the test. For the neutralizer/run controller the traces of interest are: (1) NKI - neutralizer keeper current, (2) NKV - neutralizer keeper voltage, (3) NHTI - neutralizer heater tip current, (4) NVI - neutralizer vaporizer current, and (5) NVT - neutralizer vaporizer temperature. As can be seen from

the NVT trace, the vaporizer cools off to near ambient during the 3 hr, 20 min off period (fig. 12). Typically the temperature at startup is about 20 °C.

In the discharge ignition phase the active thruster parameters are: (1) DV - discharge voltage, (2) DI - discharge current, (3) DKI - discharge keeper current, (4) DKV - discharge keeper voltage, (5) DHTI - discharge heater tip current, (6) DVI - discharge vaporizer current, and (7) DVT - discharge vaporizer temperature.

Preliminary Ground Test Results

Figures 15(a) to (c) show data on important thruster parameters. The plots are constructed from data at 10 cycle intervals from 0 to 1399 cycles. The data indicate thruster operations were stable. Perturbations were due to facilities failures or facilities/data system anomalies.

DISCUSSION

Facility Effects

A number of phenomena can invalidate any ion thruster ground test performed in a vacuum chamber. Significant facility effects include (1) inability of main chamber to hold space vacuum levels, (2) inhibition of sputter erosion by reactive background gases, (3) contamination of emissive surfaces, (4) degradation of the thruster by back-sputtered material from the vacuum system, and (5) poor thermal simulation.

The background gas (minus thruster effluents) in the main vacuum chamber has a number of sources: intrusion of atmosphere due to defective welds, nitrogen from LN₂ coolant channels, outgassing and evaporation of materials inside the chamber, backstreaming of oil and gases from the diffusion pump, sputtering of mercury and other materials from surfaces impinged by the thruster beam, and evaporation of mercury condensed on warm surfaces. During thruster operation, the last item, evaporation of condensed mercury, is insignificant compared to other sources of background gas.

As the nonorganic materials used in the vacuum chamber were chosen to minimize outgassing, and the cryosurfaces and diffusion pump have a large pumping capacity for condensable outgassed products, they should not make a significant contribution to the background gas. This then, leaves (1) evaporation of mercury from warm surfaces, (2) air from the known leak, (3) sputtered mercury and carbon, and (4) GN₂ from LN₂ leaks. The remaining background gas must principally be oxygen, water vapor, etc. from the leak. This was verified by reducing the pressure on the atmosphere side of the leak which reduced the chamber pressure by up to one-half an order of magnitude.

It is assumed here that the beam-off chamber pressure is a reasonable measure of beam-on background partial pressures, i.e., that the only gas engendered by thruster operation is mercury vapor from the thruster and target. But, there are ways in which beam-on operation could change the makeup of the background gas. Heat input from the thruster can be expected to cause increased outgassing.

Sputtering/evaporation of Hg, Mo, Carbon, Si, and other materials from the beam shield, target, and side tray is also possible. Observation of facility pressure during startup indicates, however, that after a slight increase due to high propellant flow at ignition, the pressure returns to near-background levels as the thruster is operated at high discharge power prior to beam-on. Thruster mount temperature and cryosurface temperatures show only slight variations during the beam-on run period. At shutdown the chamber pressure returns quickly to near beam-off levels. A number of thruster cycles are required for the beam-on chamber pressure to stabilize. Once this point is reached, the chamber pressure closely follows the thruster beam current.

Decreased sputter erosion. - The presence of certain gases can reduce the discharge chamber erosion rate by up to an order of magnitude. The gases react with the base metals and form sputter resistant surface films on discharge chamber surfaces (refs. 5 to 7). The magnitude of the effect depends on the competing rates for the formation and removal of the coatings. The rate of formation is proportional to the partial pressure of the reactive gas. The rate of removal depends on the energy and current density of the bombarding ions.

Data for a 30-cm thruster operating at 2 A of beam current with discharge voltages of 36 or 37 V, indicates screen grid erosion at 90 percent of maximum for total facility pressures below 6.7×10^{-5} Pa (5×10^{-7} torr) with nitrogen as the background gas (ref. 5). The equivalent pressure for the 8-cm test thruster will be somewhat lower because of the lower beam current density.

The beam-off total pressure indication on V1 is typically 2.7×10^{-6} Pa (2×10^{-8} torr) and is always below 6.7×10^{-6} Pa (5×10^{-8} torr). Even before repair of the leak it ran typically at 2×10^{-5} Pa (1.5×10^{-7} torr). Taking these readings as indicative of the nitrogen background pressure in the facility during beam-on operation, the sputter erosion of the screen grid and of the entire discharge during the ground test should be close to that which would be observed in a perfect vacuum.

Contamination of emissive surfaces. - The discharge and neutralizer cathode assemblies each contain a 20 percent porous tungsten insert impregnated with an emissive mixture. During thruster operation the surface of these inserts supplies the bulk of the electrons required to sustain the thruster discharges. The material composition and surface condition of the inserts affects the ignition characteristics of the cathodes. The functioning of the inserts has a strong impact on the operating characteristics of these discharges. Background gases can change the operational characteristics of the inserts by reacting with the cooled cathodes during the thruster off period. Contamination of the emissive surfaces during the off period is more difficult to deal with for lack of data, but pre-ignition conditioning tends to remove contamination which results from cooling. There is evidence of this from the ground test. Initially the discharge cathode underwent a shift in ignition characteristics early in the test and has since required use of the ignitor supply. However, the neutralizer, once conditioned after much contamination, has continued to ignite at very low voltages. The neutralizer is much more exposed than the discharge cathode, which is concealed in the discharge chamber behind the baffle.

Thus it appears reasonable to draw the following conclusions:

(1) Some contamination of emissive surfaces will occur during the cooldown phase but these effects will be largely to completely reversed by preheating prior to ignition and by operation of the thruster. In addition, a detailed, extensive (24 hr) conditioning of the cathodes is performed after every facility upset or shutdown in which the facility pressure rises above 10^{-2} Pa (10^{-4} torr), to reverse any contamination effects.

(2) Operation of the discharge and neutralizer cathodes is not significantly affected by the presence of background gases during thruster operation because of Hg flow rates and pressures in the cathodes and ionization in the orifices with discharges on. In addition, during cooldown, continuing mercury flow from the cooling vaporizer protects the inserts.

Back-sputtered material. - The energetic mercury ions in the beam will strike the various structures within the vacuum facility and sputter material therefrom, some of which will return to the thruster. In this test the nature of the material being back-sputtered is controlled by the use of a frozen mercury target and tray. This assures that the majority of the material returned is mercury, the most benevolent material to return to a mercury ion thruster.

The inner wall of the tray is also exposed to beam ions. It is made from 1.5 mm (0.060 in.) stainless steel covered with tantalum mesh and has been coated with colloidal graphite. The wall is inclined at 30° to the tank axis. The inclination of this wall causes the beam ions to strike the inner edge above the surface of the mercury.

The only other material back-sputtered to the thruster in any quantity is mercury. Since mercury readily evaporates from warm surfaces, it will not accumulate in the operating thruster, but may accumulate on the beam shield codeposited along with Mo.

If ingested into the discharge chamber and neutralizer, these materials will change the operating conditions of the discharges, and consequently their control setpoints. The back-sputtered materials will increase charge exchange erosion of the grids and may affect the coupling of the neutralizer to the beam. The best indication of back-sputtered material reaching the thruster is an increase in I_a when operating the thruster in a bell jar as opposed to a large tank. In addition, changes in V_g and NKV are indicators of back-sputtered material. Some back-sputtered material may be reionized resulting in increased beam current. The analysis presented should be treated as a reasonable explanation for the effects observed, due to the fact that the discharge and neutralizer flow rates are not well known.

Thermal simulation. - At first sight the thermal simulation would seem to be poor. On the spacecraft the z-module thruster sees deep space from almost the whole front hemisphere. There is also a major view of the surface of the IAPS module over which temperature can vary considerably. The thruster mounting tube is nearly thermally isolated by the gimbal, and the interior of the mounting tube views the relatively warm interior of the gimbal assembly. In the ground test, the forward view, up to 40° from the centerline, is of the target and tray at -100°C . From 40° to about 80° from the centerline, the view is of the warm tank walls through the perforated metal of the -75°C cold

wall. The remainder of the surroundings are at 25 °C. The thruster mounting tube is well coupled to the large thermal mass of the mount.

However, cooldown tests with a prototype thruster instrumented with a thermocouple on the mounting tube near the backplate as well as the thermocouples on the vaporizers and the mount, indicate that the solid stainless steel "ground screen" and ground screen mask form an effective heat shield around the thruster. In these tests the two vaporizer temperatures, which differed by 35 °C during thruster operation, became essentially identical about 5 min after shutdown and remained within 5 °C of each other for the next 2 hr of the cooldown. The mounting tube temperature remained about halfway between the vaporizer temperature and the mount temperature during cooldown. With the test thruster, following a 2 week cold soak, the discharge vaporizer temperature (DVT) was 2.2 °C and the neutralizer vaporizer temperature (NVT) was -7 °C. The data indicates that once internal heat sources are removed the major portion of the thruster rapidly assumes a uniform temperature with some conduction down the mounting tube. Calculations, using the measured temperature difference between the upper end of the mounting tube and mount, for the prototype thruster, indicate that during operation less than 9 W are conducted down the mounting tube. During the run period the mount temperature increases slightly, warming to 15 to 20 °C above room temperature.

From this it appears reasonable to conclude that during thruster operation the major heat loss is by radiation from the grids and, to a lesser extent, by radiation and some conduction down the mounting tube and feedlines. Similar conclusions were reached from thermal testing of 30-cm ion thrusters (ref. 8). As mounted for the flight test, the thruster gimbal is located in the relatively warm interior of the spacecraft. Calculations show that during operation the test thruster temperature distribution should be close to that which will exist during operation on the spacecraft. The initial cooldown is probably somewhat more rapid because of increased conduction down the thruster mounting tube. The ultimate cold soak temperatures are somewhat warmer than flight because of increased coupling of the thruster to the room temperature mount and upper bell jar.

The thermal simulation is reasonably good with possibly a slight reduction in some thruster operating temperatures due to enhanced heat conduction through the thruster mounting tube. The initial rate of fall of thruster temperature at cooldown may also be increased slightly for the same reason.

During warmup in the ground test thruster, the gain and dynamic characteristics of the commercial isolation amplifier change, so the adjustment of loop gain (which is done manually) is a compromise. The gain is set to produce a mildly underdamped response in the final, stabilized, state of thruster operation. This results in a significantly underdamped response when the thruster beam is first established. Thruster gain soon after beam-on is actually lower than in the final stabilized state but the change in thruster dynamic characteristics causes continuous, low amplitude oscillations in vaporizer current while the thruster is in this state. Because of the relatively low loop gain, the thruster gain shift also produces a drop in the average value of V_6 of up to 0.5 V between the two states. Because of possible differences in overall loop gain, it cannot be said that this control process absolutely duplicates flight conditions. However, once the beam-on transition is completed and the transient has subsided there is no noticeable variation in V_6 other than that

from the deliberate perturbation discussed elsewhere. The possible difference in controller gain should have an insignificant effect on the ground test results.

Assessment of facility effects. - The test facility provides a reasonable simulation of the most important characteristics of the environment experienced by the thruster on the spacecraft. The simulation is not perfect. During stable full-beam operation of the test, the impact of these facility effects should not be so great as to impair the validity of the test. Sputter erosion of the discharge chamber may be somewhat less than the amount occurring in flight, due to the protective effect of the background nitrogen in the ground test. This presumes that the discharge voltage and flow rate are the same in both. Operation of the discharge and neutralizer cathodes plus the neutralizer coupling to the beam, may be slightly perturbed by the back-sputtered flux in the ground test. Increased charge exchange erosion of the accelerator grids is known to occur from the measured I_a , providing an increased source of sputtered molybdenum to contaminate other thruster surfaces, principally the beam shield, the neutralizer, and the ground screen mask. Sputtered carbon and stainless steel from the facility structure will also deposit out on these surfaces and some will penetrate into the discharge chamber. The back-sputtered material ingested into the discharge chamber will be largely ionized, and a portion will be accelerated as part of the ion beam, thereby altering the thruster operating point. In any event, changes in thruster surfaces should not be life limiting and should not perturb thruster operation to any noticeable extent.

Power Electronics Unit

In the flight PEU the supplies for the vaporizer and tip heaters produce a 10-kHz ac square wave. In the ground test, dc supplies are used. The current in the cathode tip heaters can produce noticeable magnetic fields in the immediate vicinity of the discharge and neutralizer cathodes. The axial, dc magnetic field on the centerline of the discharge cathode at the end of the heater coil is about 25 G at startup and 14 G during beam-on run. The corresponding field values at the downstream end of the neutralizer cathode orifice are 5.5 G at startup and 2.7 G during beam-on run. In flight the fields would be alternating at 10 kHz and would probably be reduced somewhat in amplitude by the shielding effect of the cathode structure and discharge chamber magnetic circuit.

The effects of this difference in heater operation are difficult to estimate. It cannot be said categorically that the effects are negligible. However, no gross differences between the operation of the test thruster using dc heater supplies and ion thrusters using 10-kHz ac heater supplies have been noted.

There are other differences in power supply characteristics between the ground test and flight. The ground test keeper supplies have an open circuit voltage of about 30 V while the flight PEU keeper supplies produce about 45 V at no load. However, no excessive tendency for the keeper discharges to extinguish has been observed. The open circuit voltage of the ground test discharge supply is also somewhat lower than the flight value.

The screen and accelerator supplies in the flight PEU use high frequency switching mode regulators. Their output filter capacitors are of relatively modest size (0.47 μ fd for the screen and 0.1 μ fd for the accelerator). Kepco BHK 2000-0.1(m) commercial supplies are used for the ground test. To reduce power supply mortality during recycles, the Kepco supplies were converted to the manufacturer's "HS" option which removes essentially all output capacity and increases the response speed of the supply.

The effect of this difference in the screen and accelerator supplies on thruster life is difficult to estimate. For instance, the absence of grid arcs will prevent pitting and sputtering of grid material and could enhance thruster life, but it could allow whiskers or flakes of sputtered material to grow across the gap between the grids and cause a permanent short circuit. Which of these possible effects is the more significant is unknown. In the flight supply there exists a grid clear circuit which helps to remove any flakes of sputtered material which might deposit between grids.

The overcurrent sensing (fig. 7) used for the ground test differs significantly from flight. In the ground test, overcurrent sensing is used on the accelerator supply as well as the screen supply. This was done to provide additional protection to the thruster from possible malfunction in, or maladjustment of, the relatively high current (greater than 100 mA) commercial power supply used for the accelerator. The current limit on this supply is adjusted to 20 mA during thruster operation. Secondly, the time constant of the circuitry feeding the overcurrent sensing comparators is much longer than that used for flight. The difference arose principally from the need to protect the recycle circuitry from the extreme voltage transients resulting from discharge of the screen and accelerator supply output capacitors (2 μ fd each until removal) during a grid arc. Finally, the life test circuitry contains a fixed delay of about 75 msec not used for flight. The entire overcurrent/recycle circuit floats with thruster neutralizer common in an electrically noisy environment. The additional filtering was added to prevent nuisance overcurrent trips.

Following its initiation, the recycle sequence proceeds in a manner which closely resembles flight. Both the screen and accelerator supplies are immediately programmed to 0 V. The discharge current is ramped to a low current setpoint at a controlled rate. This status is held for about 1 sec. The accelerator supply is then turned on and begins to ramp up with a controlled time constant. Two hundred milliseconds later the screen supply is turned on and approaches its final value with another controlled time constant. Finally, 300 msec later, the programming input for the discharge supply is returned to its normal input value and the discharge current returns to its normal value at a controlled rate completing the recycle sequence. The same recycle sequence is also used in turning the screen and accelerator supplies on and off as required by the test controller.

For the ground test upper and lower limits of 73 and 71 mA were initially chosen. However, the circuit has shown a certain tendency to allow the beam current to drift up with time and temperature and so has been readjusted periodically to keep the operating beam current reasonably close to 72 mA. The flight system used limits of 73 and 70 mA.

Discharge vaporizer control - There are some indications that the IAPS thruster difference voltage may have a "valley" shape as vaporizer flow (a function of temperature having multiple values) increases. To prevent the control loop from remaining in the wrong region a discharge vaporizer temperature control loop was added. This loop has relatively low gain and a long time constant. A significant temperature transient again produces a vaporizer power reduction, which usually results in the voltage control loop regaining control on recovery. Not shown on the block diagram is a V_S voltage sensing circuit which disables both the gain and temperature loops if V_S rises past a preset limit. It changes the long time constant integrators in both loops in a direction which allows full vaporizer current, and thus reduces the chances of extinguishing the thruster discharge because high V_S usually indicates too low a flow rate.

The IAPS ground test thruster has proven difficult to "flood" during normal beam-on operation. It appears that the increase in discharge current by the beam-current controller as a beam current starts to fall with excessive propellant flow almost precludes "flooded" operation. The controller was checked out and adjusted using a prototype thruster. With some effort it was possible to get this thruster into something approaching a "flooded" condition. Lack of flooding may be due to higher than normal discharge current for normal beam-full operation. After proper adjustment the controller did indeed cut back the vaporizer power to a point which would allow recovery. However, adjustment of the gain loop proved difficult. Too much loop gain caused excessive overshoot and extinguished the discharge. It was difficult to find a combination of settings which were effective in curing the flooded condition without extinguishing the thruster, and also allowed enough time for the voltage control loop to become active before the control loop released its control and again allowed the "flooded" condition to resume. Tests were performed by turning the controller on into an already "flooded" thruster.

It proved impossible to get the ground test thruster into a flooded state with reasonable perturbation of the operating state. Hence, the controller was not tested with the ground test thruster. From an examination of the strip chart data, it is highly unlikely that the anti-flooding functions have ever been active. There is no indication that the test thruster has ever been in a flooded state. Other than creating the continuous small perturbation, it is unlikely that this additional circuitry has had any effect on the ground test.

RTD signal conditioning. - The IAPS thruster uses platinum Resistance Temperature Detector (RTD) to measure the temperature of the discharge and neutralizer vaporizers. The resistance at 0 °C is 200 Ω. In the flight system current is only applied to the RTDs during a short interval while the temperature is actually being sensed by the DCIU.

For the ground test, continuous temperature signals are required for control and data system purposes. In order to be discernible above the noisy background, the sensors must produce a large signal. But since self heating must be minimized, the sensors are given a pulse of current, about 13 mA, for approximately 10 msec duration every 100 msec. This results in an average sensor dissipation of 8.4 mW at 400 °C.

According to the manufacturers specifications, a platinum RTD, immersed in flowing oil, can dissipate 60 mW with only a 1° shift in reading. Since the

IAPS sensors are attached to the vaporizers through a low thermal resistance bracket, this level of self heating should produce negligible error.

The pulsed voltage signal, which corresponds to the vaporizer temperature, is offset so that a 0 to 5 V span corresponds to temperatures from -50 to 450 °C. The signal is then applied to a sample and hold circuit which supplies a dc output to the data system, various analog controllers and the ground test controller.

Parameter Sensing

For control purposes certain signals must be sensed to determine thruster status. In addition to the vaporizer temperatures discussed above, the level of discharge and neutralizer keeper current, beam current, and discharge current must be sensed on a go/no-go basis. To provide this sensing, simple comparators are used on the current signals involved. For keeper and discharge currents only a single decision point is required. For the beam current two points are sensed, one to indicate beam-on and one to indicate low beam. To allow recycles to occur without causing a low beam trip, a single 31-sec time constant has been inserted in the beam current signal ahead of the comparators.

Mercury Feed System

To simulate flight operation, the mercury feed system must deliver propellant to the thruster vaporizers with a pressure between 1×10^5 and 2.4×10^5 Pa (15 and 35 psia). This pressure range arises because the flight system uses nitrogen gas in a blowdown configuration to expel mercury from the tank, the pressure dropping as the propellant is consumed. In addition, because of the buildup of propellant impurities in the thruster vaporizer (ref. 9), the entire feed system must be made of materials which are compatible with mercury and the mercury must be very pure.

The system is equipped with calibrated burettes for measuring propellant flow. However, flow measurements are complicated by the relatively large volume of mercury contained in the polyethylene tubing. The bulk thermal expansion modulus of polyethylene is about twice that of mercury, which leads to a negative "thermometer effect." Calculations indicate that a 5 °C change in temperature produces a drop in the mercury level in the discharge vaporizer burette equivalent to that produced by about 1 hr of beam-on operation. To obtain flow measurements of reasonable accuracy, long periods of stable operation are required. In addition, the change in height of the burettes produces significant pressure change on the remainder of the system. Hence an additional correction is needed to obtain the true mercury flowrates from the column height versus time measurements with the burettes. It should be noted that entrapped gas and changes in the applied pressure can cause errors in burette measurements.

The principal shortcomings of the feed system arise from the use of plastic tubing which was chosen to allow the mechanical motion and provide electrical insulation (the entire feed system is electrically isolated) required by other system considerations.

Quality of Simulation

The Controller Description section of this paper provides a detailed examination of the ground test controller and its programming. It includes a comparison with the relevant portions of the flight control algorithms. As can be seen from this section, the normal ground test cycle presented gives a good approximation of expected flight operation. There are, however, some notable differences in the ground test operation. These include:

- (1) An extended "pre-beam" state
- (2) A simplified beam-on transition with a higher peak discharge typically 47 V, which takes about 30 sec for the discharge vaporizer control circuit to begin to correct
- (3) Higher neutralizer vaporizer temperature during preheat and at ignition with a somewhat lower neutralizer flowrate at ignition
- (4) Lower neutralizer keeper voltage control point with much reduced flow
- (5) Longer time after cathode ignition before tip heat reduction
- (6) Different run time reference difference voltage
- (7) Different run and off times, i.e., colder starts and longer run time

CONCLUDING REMARKS

The operating conditions of this ground test are the result of a series of compromises. The significant question is the adequacy of the simulation for the purpose of the test. The purpose of this test is to verify durability of IAPS thrusters for flight applications and to identify performance changes and degradation effects with operating time and cycles.

The environment presented to the thruster should not inhibit sputter erosion or contaminate the cathodes significantly during operation. Some minor contamination may occur during the thruster off period however, this should be reversed to a large extent by the normal startup procedure. The major component of the material back-sputtered from the vacuum facility by the thruster beam is mercury which should not impair thruster operation.

The test controller commands the thruster to execute startup/run and shutdown cycles which closely approximate nominal flight operation using the flight PEU and DCIU. Care has been taken to simulate the important dynamic characteristics of the PEU. Notable differences between test and flight operations include screen and accelerator supply characteristics, the use of dc heater supplies, the higher neutralizer vaporizer temperature at ignition and during operation and the simplified beam-on transition used for this test. In addition, the operating neutralizer keeper voltage and discharge chamber difference voltage setpoints differ slightly from those used for flight. These differences should not effect the overall validity of the test.

This paper deals with IAPS ground test data up to October 31, 1983. The thruster performed as expected in a stable manner and accumulated 1399 cycles and 3593 beam-on hours.

Lack of funding to continue testing forced a temporary shutdown of the ground test until February 17, 1987. During this dormant period the thruster was retracted and stored in the bell jar upper chamber in an argon atmosphere.

Modifications to the data system were made, and operational capability which closely approximated on-orbit operation was added.

The ground test was continued on February 17, 1987, and will be considered complete when 2557 cycles and 7052 beam-on hours have been accumulated. This occurred in February 1988. This testing period will be addressed in detail in a future paper.

REFERENCES

1. Power, J.L.: Planned Flight Test of a Mercury Ion Auxiliary Propulsion System, I - Objectives, Systems Descriptions, and Mission Operations. AIAA Paper 78-647, Apr. 1978. (Also, NASA TM-78859).
2. Mantenieks, M.A.; and Wintucky, E.G.: 5200 Cycle Test of an 8 cm Diameter Mercury Ion Thruster. AIAA Paper 78-649, Apr. 1978. (Also, NASA TM-78860).
3. Nakanishi, S.: A 15,000 Hour Cyclic Endurance Test of an 8 cm Diameter Electron Bombardment Mercury Ion Thruster. AIAA Paper 76-1022, Nov. 1976. (Also, NASA TM X-73508).
4. Kerslake, W.R.: SERT-II Thrusters-Still Ticking After Eleven Years. AIAA Paper 81-1539, July 1981. (Also, NASA TM-81774).
5. Rawlin, V.K.; and Mantenieks, M.A.: Effect of Facility Background Gases on Internal Erosion of the 30 cm Hg Ion Thruster. AIAA Paper 78-665, Apr. 1978. (Also, NASA TM-73803).
6. Mantenieks, M.A.; and Rawlin, V.K.: Sputtering in Mercury Ion Thrusters. AIAA Paper 79-2061, Oct. 1979. (Also, NASA TM-79266).
7. Beattie, J.R.: A Model for Predicting the Wearout Lifetime of the LeRC/Hughes 30 cm Mercury Ion Thruster. AIAA Paper 79-2079, Oct. 1979.
8. Oglebay, J.C.: Comparison of Thermal Analytic Model with Experimental Test Results for 30 cm Diameter Engineering Model Mercury Ion Thruster. NASA TM-X-3541, 1977.
9. Fearn, D.G.: Thruster Component Life-Testing Under Cyclic and Steady-State Conditions. AIAA Paper 76-987, Nov. 1976.
10. Andersen, H.H.: The Energy Efficiency of Lead Self-Sputtering. Appl. Phys. Lett., vol. 13, no. 3, Aug. 1, 1968, pp. 85-86.
11. Askerov, S.G.; and Sena, L.A.: Cathode Sputtering of Metals by Slow Mercury Ions. Sov. Phys. - Solid State, vol. 11, no. 6, Dec. 1969, pp. 1288-1293.
12. Behrisch, R., et al.: The Sputtering Mechanism for Low-Energy Light Ions. Appl. Phys., vol. 18, no. 4, Apr. 1979, pp. 391-398.

13. Cobine, J.D.: Gaseous Conductors, Theory and Engineering Applications. Dover, 1958, p. 32.
14. Collett, C.; and Power, J.L.: Qualification Test Results of IAPS 8 cm Ion Thrusters. AIAA Paper 82-1954, Nov. 1982.
15. Guthrie, A.; and Wakerling, R.K.: Vacuum Equipment and Techniques. McGraw-Hill, New York, 1949.
16. Herron, B.G., et al.: Engineering Model 8 cm Thruster System. AIAA Paper 78-646, Apr. 1978.
17. Holanda, R.: Sensitivity of Hot-Cathode Ionization Vacuum Gages in Several Gases. NASA TN D-6815, 1972.
18. Jenkins, R.O.; and Trodden, W.G.: The Poisoning of Impregnated Cathodes. J. Electron. Control, vol. 7, no. 5, Nov. 1959, pp. 393-415.
19. Kaminsky, M.: Atomic and Ionic Impact Phenomena On Metal Surfaces. Academic Press, 1965.
20. Kaufman, H.R.: An Ion Rocket with an Electron-Bombardment Ion Source. NASA TN D-585, 1961.
21. Kennard, E.H.: Kinetic Theory of Gases. McGraw-Hill, 1938.
22. Kerlake, W.R.; and Banks, B.A.: Evolution of the 1-mlb Mercury Ion Thruster Subsystem. AIAA Paper 78-711, Apr. 1978. (Also, NASA TM-73733).
23. Komatsu, G.K.; and Stellen, J.M. Jr.: Beam Efflux Measurements. NASA CR-135038, 1976.
24. Miller, R.L.: ESCORT: A Data Acquisition and Display System to Support Research Testing. NASA TM-78909, 1978.
25. Robinson, M.T.: The Energy Spectra of Atoms Slowing Down in Structureless Media. Philos. Mag., vol. 12, no. 115, July 1965, pp. 145-156.
26. Robson, R.R.; and Low, C.A. Jr.: Software and System Level Tests of a Test Flight Mercury Ion Thruster Subsystem. AIAA Paper 82-1912, Nov. 1982.
27. Scialdone, J.J.: Internal Pressures of a Spacecraft or Other System of Compartments, Connected in Various Ways and Including Outgassing Materials, in a Time-Varying Pressure Environment. NASA TM X-63869, 1969.
28. Sigmund, P.: Theory of Sputtering. I. Sputtering Yield of Amorphous and Polycrystalline Targets. Phys. Rev., vol. 184, no. 2, Aug. 10, 1969, pp. 383-416.
29. Thompson, M.W.: II. The Energy Spectrum of Ejected Atoms During the High Energy Sputtering of Gold. Philos. Mag., vol. 18, no. 152, Aug. 1968, pp. 377-414.
30. 8 cm Mercury Ion Thruster Subsystem Users Manual. NASA CR-162209, 1977.

31. Wehner, G.K.: Low-Energy Sputtering Yields in Hg. Phys. Rev., vol. 112, no. 4, Nov. 15, 1958, pp. 1120-1124.
32. Wehner, G.K.: Forces on Ion-Bombarded Electrodes in Low-Pressure Plasma. J. Appl. Phys., vol. 31, no. 8, Aug. 1960, pp. 1392-1397.
33. Weigand, A.J.: Operating Characteristics of a Hollow-Cathode Neutralizer for 5 and 8 cm Diameter Electron Bombardment Mercury Ion Thrusters. NASA TM X-3209, 1975.
34. Williamson, W.S., et al.: 8 cm Engineering Model Thruster Technology: A Review of Recent Developments. AIAA Paper 79-2103, Oct. 1979.
35. Winterbon, K.B.: Range-Energy Data for KeV Ions in Amorphous Materials. Atomic Energy of Canada Limited, Chalk River, Ontario, AECL-3194, Nov. 1968.

TABLE I. - POWER SUPPLY CHARACTERISTICS

Life test								Flight						
Supply	Type	Regulation	Open circuit voltage, V	Short-circuit current, mA	Rated output		Control	Type	Regulation	Open circuit voltage, V	Short-circuit current, mA	Rated output		Control
					V	A						V	A	
Screen (VSCR)	dc	Voltage	^a 1182	^b 100	2000	0.100	On/off	dc	Voltage	1200	(c)	1200	0.090	On/off
Accelerator (VA)	dc	Voltage	300	^b 20	2000	.100	On/off	dc	Voltage	300	8.0	298	1	On/off
Discharge (Δ VI)	dc	Current	95	-----	50	1	Setpoints/ JB control	dc	Current	>120	---	50	1	Setpoints/ JB control
Discharge keeper (VDK)	dc	Current	31.4	-----	28	0.5	Setpoints	dc	Current	60	---	25	0.5	Setpoints
Discharge keeper ignitor	dc	None	400	11	-----	-----	On/off	dc	None	>400	---	50	.014	On/off
Discharge cathode tip heater (VCT)	dc	Current	24	-----	12	5	Setpoints	ac	Current	10	---	10	4	Setpoints
Discharge vaporizer (VDV)	dc	Current	15	-----	5.5	5	Setpoints/ V _u control	ac	Current	10	---	6	3	Setpoints/ V _u control
Neutralizer keeper (VNK)	dc	Current	28.7	-----	28	0.5	Setpoints	dc	Current		---	23	0.6	Setpoints
Neutralizer keeper ignitor	dc	None	386	10.7	-----	-----	On/off	dc	None	>400	---	50	.014	On/off
Neutralizer tip heater (VNT)	dc	Current	24	-----	12	5	Setpoints	ac	Current	10.3	---	10	4	Setpoints
Neutralizer vaporizer (VNV)	dc	Current	15	-----	5.5	5	Setpoints/ V _{NK} control	ac	Current	4.3	---	4	2	Setpoints/ V _{NK} control

^aCommercial, series pass, voltage-regulated supply (KEPCO BHK 2000-0.1 M (HS)) with output voltage set as shown.

^bCommercial supply; current limit set as shown; recycle circuitry limit current to 20 mA.

^cSupply shuts down on overcurrent and turned on during recycle sequence.

TABLE II. - DATA SYSTEM CHANNEL LIST

Channel number	Symbol	Parameter measured	Input range, V	Engineering units	Conversion factor
1	BMI	J(B) BEAM	+1	+100 mA	X100[MA/V]
2	DI	J(I) DISC	+1	+1 A	X1[A/V]
3	DV	DISC VLTS	+0.5	+50 V	X100[V/V]
4	DKI	J(CK)	+1	+1000 mA	X1000[MA/V]
5	DKV	V(CK)	+0.5	+50 V	X100[V/V]
6	DHTI	J(CT)	+0.5	+5 A	X10[A/V]
7	DHTV	V(CT)	+1	+10 V	X10[V/V]
8	DVI	J(CV)	+0.5	+5 A	X10[A/V]
9	DVV	V(CV)	+0.5	+5 V	X10[V/V]
10	DVT	TEMP MVAP	+5	-50 C +450 C	[A]
11	NKI	J(NK)	+1	1000 mA	X1000[MA/V]
12	NKV	V(NK)	+0.5	+50 V	X100[V/V]
13	NHTI	J(NT)	+0.5	+5 A	X10[A/V]
14	NHTV	V(NT)	+1	+10 V	X10[V/V]
15	NVI	J(NV)	+0.5	+5 A	X10[A/V]
16	NVV	V(NV)	+0.5	+5 V	X10[V/V]
17	NVT	TEMP NVAP	+5	-50 C +450 C	[B]
18	ACCI	J(A)	+1	+10 mA	X10[MA/V]
19	ACCV	V(A)	+0.5	+500 V	X1000[V/V]
20	SV	V(SCR)	+1.5	+1500 V	X1000[V/V]
21	NFPV	V(G)	±0.5	±50 V	X100[V/V]
22	DSTS	DISC STAT	+7.5	Integer 0 to 15	[C]
23	NSTS	DISC STAT	+7.5	Integer 0 to 15	[D]
24	TTMP	TARGET TEMP.	+3.2	-320 F	[E]
25	VAC	TANK PRESSURE	+1	E-3 TORR E-7 TORR	[F]

$$[A] \text{ DVT[CENTIGRADE]} = 100 * V(10) - 50$$

$$[B] \text{ NVT[CENTIGRADE]} = 100 * V(17) - 50$$

$$[C] \text{ DSTS[DIMENSIONLESS]} = \text{TRUNCATE} ((V(22) + .25) * 2.0)$$

$$[D] \text{ NSTS[DIMENSIONLESS]} = \text{TRUNCATE} ((V(23) + .25) * 2.0)$$

$$[E] \text{ TTMP[FAHRENHEIT]} = -100.0 * V(24)$$

$$[F] \text{ VAC[TORR]} = 9.607E - 11 * \text{EXP} (17.81489 * V(25))$$

Note: [XXX] indicates dimension of conversion factor or reference to conversion equation.

V(NN) = True voltage input to channel NN of scanner in volts.

TABLE III. - TYPICAL OPERATING PRESSURES

Ion gage	Indicated beam-off pressure, torr		Indicated beam-on pressure, torr		Corrected beam-on pressure, torr	Beam-on number density at 25 °C 1/cm ³
	Before 1/21/83	After 1/21/83	Before 1/21/83	After 1/21/83	After 1/21/83	After 1/21/83
V1	1.5x10 ⁻⁷	2x10 ⁻⁸	1.5x10 ⁻⁶	9x10 ⁻⁷	4.1x10 ⁻⁷	1.34x10 ¹⁰
V2	2x10 ⁻⁷	6x10 ⁻⁸	1.5x10 ⁻⁶	9x10 ⁻⁷	4.1x10 ⁻⁷	1.34x10 ¹⁰
V3	4x10 ⁻⁷	1.5x10 ⁻⁷	2x10 ⁻⁶	1.5x10 ⁻⁶	6.9x10 ⁻⁷	2.24x10 ¹⁰

TABLE IV. - NEUTRALIZER/RUN CONTROLLER PROGRAMMING

State no.	Neut. vap. field	Neut. tip heat field, A	Neut. keeper field, mA	Ignitor on/off field	Remarks	Jump address field	Jump trigger field	Incr. trigger field, sec	Clear timer on exit	Shutdown trigger field	Clear S/D timer on exit	Record data on exit	Print data on exit	Disc. flag field
0	Off	Off	Off	Off	Shutdown	00	None	Off time 12 600	Yes	None	No	No	No	Clear
1	0.67 A	1.30	Off	Off	Preheat low	00	None	8	Yes	None	No	No	No	Clear
2	1.10 A	2.65	Off	Off	Preheat	03	NVT >370 °C	960	Yes	None	No	Yes	Yes	Clear
3	Control NVT ^a	2.65	Off	Off	Control vap. temp.	00	None	180	Yes	None	Yes	Yes	No	Clear
4	1.10 A	2.65	510	Off	LV keeper on	07	NKI >100 mA	8	Yes	S/D timer 1380 sec	No	No	No	Clear
5	1.10 A	2.65	510	On	Ignitor on	07	NKI >100 mA	8	Yes	S/D timer 1380 sec	No	No	No	Clear
6	Control NVT ^a	2.65	Off	Off	Control vap. temp.	04	60 sec	None	Yes	S/D timer 1380 sec	No	Yes	No	Clear
7	1.10 A	2.65	510	Off	Keeper lit	06	NKI <100 mA	8	Yes	S/D timer 1380 sec	No	No	No	Clear
8	0.87 A	1.30	510	Off	Reduce tip heat	06	NKI <100 mA	180	Yes	S/D timer 1380 sec	No	Yes	No	Clear
9	Auto (NKV=15.6 V)	1.30	510	Off	Establish	06	NKI <100 mA	180	Yes	S/D timer 1380 sec	No	Yes	No	Clear
10	Auto (NKV=15.6 V)	1.30	510	NKV control Off	Stabilize	06	NKI <100 mA	300	Yes	None	Yes	Yes	Yes	Clear
11	Auto (NKV=15.6 V)	1.30	510	Off	Check for beam on	13	Disc. flag 2 sec	8	Yes	NKI <100 mA	No	No	No	Set
12	Auto (NKV=15.6 V)	1.30	510	Off	Check for time out	11		None	Yes	S/D timer 1380 sec	No	No	No	Set
13	Auto (NKV=15.6 V)	1.30	510	Off	First run state	00	None	300	No	NKI <100 mA	No	Yes	Yes	Clear
14	Auto (NKV=15.6 V)	1.30	510	Off	Second run state	00	None	Run time 10 800	No	NKI <100 mA	No	No	No	Clear
15	Auto (NKV=15.6 V)	1.30	510	Off	Shutdown	00	None	None	No	S/D immed	No	No	No	Clear

^a370° < NVT < 380 °C.

TABLE V. - DISCHARGE CONTROLLER PROGRAMMING

State no.	Disc. vap. field	Disc. tip heat field, A	Disc. keeper field, mA	Ignitor on/off field	Disc. current field, mA	H.V. on/off field	Remarks	Jump address field	Jump trigger field	Incr. trigger field, sec	Clear timer on exit	Shutdown trigger field	Clear S/D timer on exit	Record data on exit	Print data on exit	Disc. flag field
0	Off	Off	Off	Off	Off	Off	Shutdown	00	None	Off time 12 600	Yes	None	No	Yes	Yes	Clear
1	1.27 A	1.16	Off	Off	Off	Off	Preheat low	00	None	8	Yes	None	No	No	No	Set
2	2.32 A	2.92	Off	Off	Off	Off	Preheat	03	DVT >275 °C	1400	Yes	None	Yes	Yes	Yes	Clear
3	Control DVT ^a	2.92	Off	Off	Off	Off	Control vap. temp.	00	None	180	Yes	S/D timer 650 sec	No	Yes	Yes	Clear
4	2.18 A	2.92	385	Off	Off	Off	LV keeper on	06	DKI >50 mA	8	Yes	S/D timer 650 sec	No	No	No	Clear
5	2.18 A	2.92	385	On	Off	Off	Ignitor on	00	None	8	Yes	S/D timer 650 sec	No	No	No	Clear
6	2.18 A	2.92	385	Off	Off	Off	Keeper lit	03	DKI <50 mA	8	Yes	S/D timer 650 sec	No	Yes	No	Clear
7	2.00 A	2.14	385	Off	Off	Off	Reduce tip heat	03	DKI <50 mA	16	Yes	S/D timer 650 sec	No	Yes	No	Clear
8	2.00 A	1.16	385	Off	Off	Off	Reduce tip heat	03	DKI <50 mA	16	Yes	S/D timer 650 sec	Yes	Yes	No	Clear
9	2.00 A	1.16	385	Off	340	Off	Discharge supply on	11	DI >100 mA	8	Yes	S/D timer 650 sec	No	No	No	Clear
10	2.00 A	1.16	385	Off	Off	Off	Discharge supply off	09	2 sec	None	Yes	S/D timer 650 sec	No	No	No	Clear
11	Control DVT ^a	1.16	120	Off	700	Off	Discharge heat	00	None	300	Yes	None	No	Yes	Yes	Clear
12	Auto (Vu=25 V)	1.16	120	Off	340	Off	Establish Vu control	00	None	300	Yes	DI <100 mA	No	Yes	Yes	Clear
13	Auto (Vu=25 V)	1.16	120	Off	340	Off	Wait for neut.	14	Neut flag	None	Yes	DI <100 mA	No	Yes	No	Clear
14	Control DVT ^a	1.16	385	Off	340	Off	Pre-beam	00	None	300	Yes	DI <100 mA	No	Yes	Yes	Clear
15	Auto (Vu=25 V)	1.16	120	Off	Auto (BMI=72 mA)	On	Beam on	16	BMI >62 mA	300	Yes	DI <100 mA	No	Yes	Yes	Clear
16	Auto (Vu=25 V)	1.16	65	Off	Auto (BMI=72 mA)	On	Run	00	None	None	No	BMI <34 mA	No	No	No	Set

^a265 °C < DVT < 285 °C.

TABLE VI. - PHYSICAL CHARACTERISTICS OF THE TEST THRUSTER (S/N 905)

Beam current (J_B)	72 mA
Discharge vaporizer flow rate (J_{D0})	90 mA (Eq)
Discharge molecular flow rate (N_{DC})	5.62×10^{17} (1/sec)
Neutralizer vaporizer flow rate (J_{NO})	7.8 mA (Eq)
Neutralizer molecular flow rate (N_N)	4.87×10^{16} (1/sec)
Discharge utilization efficiency ($\hat{\epsilon}_D$)	0.80
Discharge anode diameter	8.57 cm
Discharge anode length	6.60 cm
Total area of discharge chamber	293 cm ²
Center portion of accel. grid	
Diameter of holes	0.1143 cm
Number of holes	534
Open area	5.48 cm ²
Diameter of region	5.33 cm
Area of region (A_{TC})	22.3 cm ²
Open fraction (f_C)	0.245
Outer portion of accel. grid	
Diameter of holes	0.0889 cm
Number of holes	666
Open area	4.13 cm ²
Inner diameter of region	5.33 cm
Outer diameter of region	8.00 cm
Area of region (A_{TO})	27.92 cm ²
Open fraction (f_O)	0.148
Total area of grids	50.26 cm ²
Total open area of grids (A_G)	9.61 cm ²
Average open fraction of grids (R_G)	0.191
Ratio open area to discharge chamber area	3.3 percent
Operating temperature, disc. chamber walls	400° C
Neutralizer keeper aperture diameter	0.178 cm

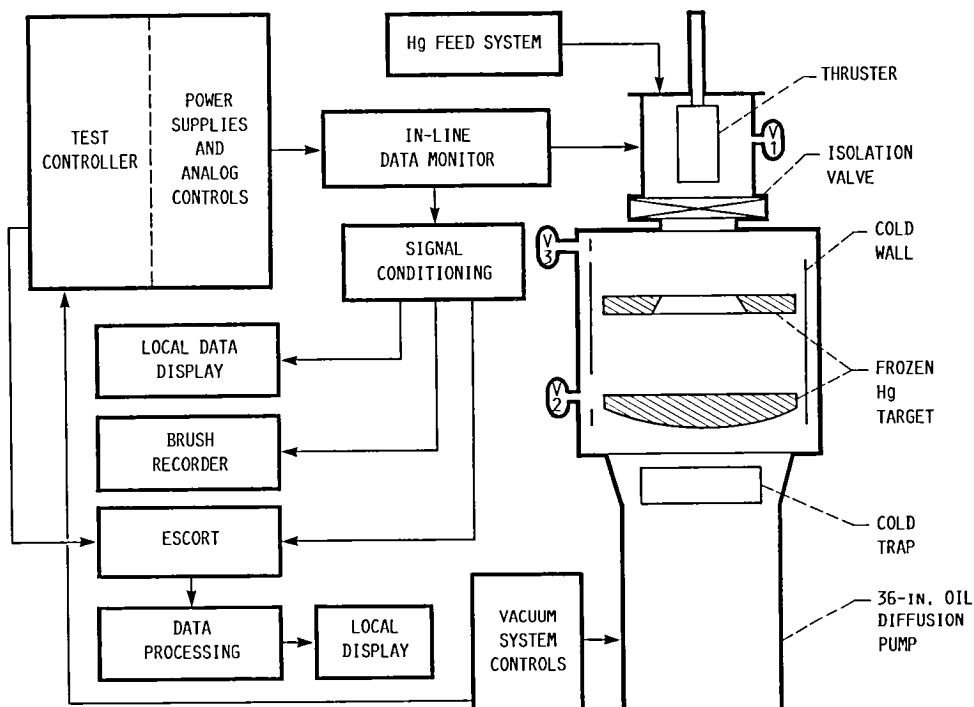

FIGURE 1. - GROUND TEST FACILITY, BLOCK DIAGRAM.

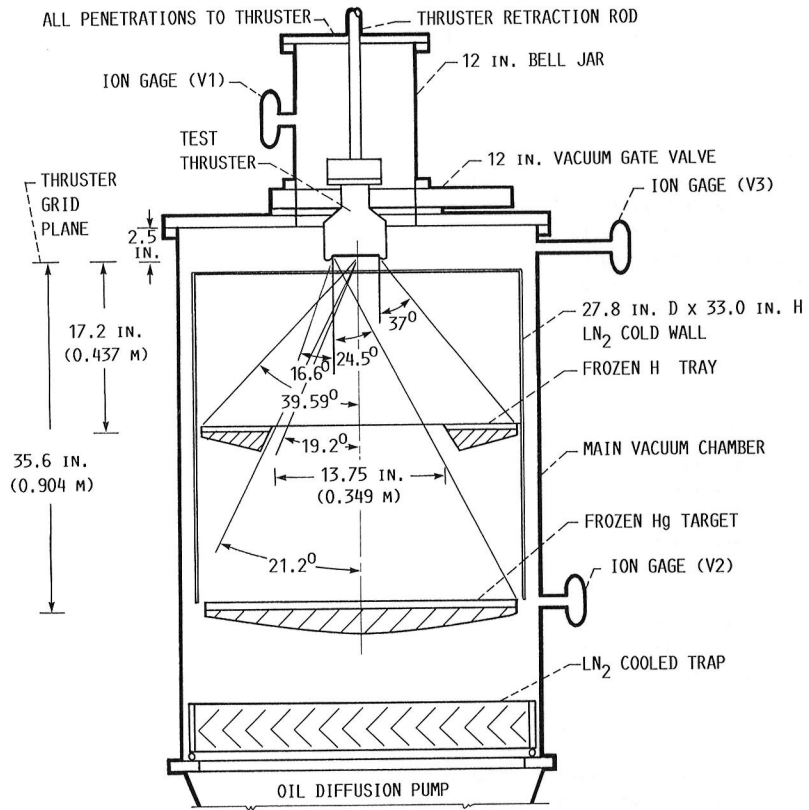

FIGURE 2. - MAIN VACUUM CHAMBER.

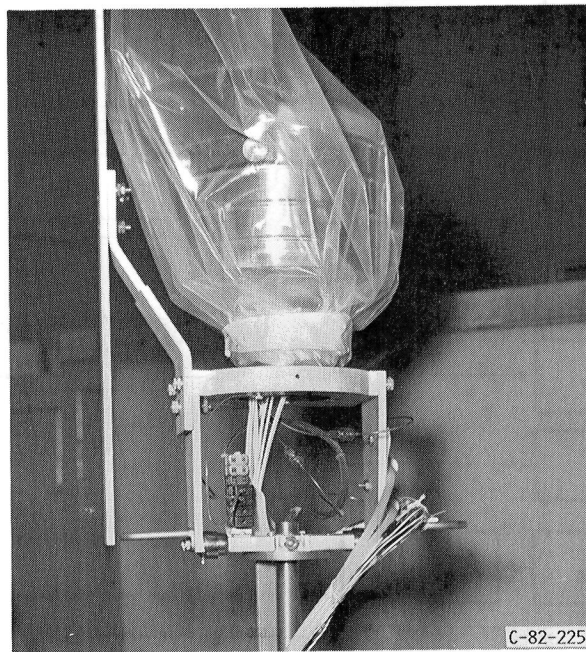

FIGURE 3. - TEST THRUSTER MOUNTED AND READY FOR INSTALLATION.

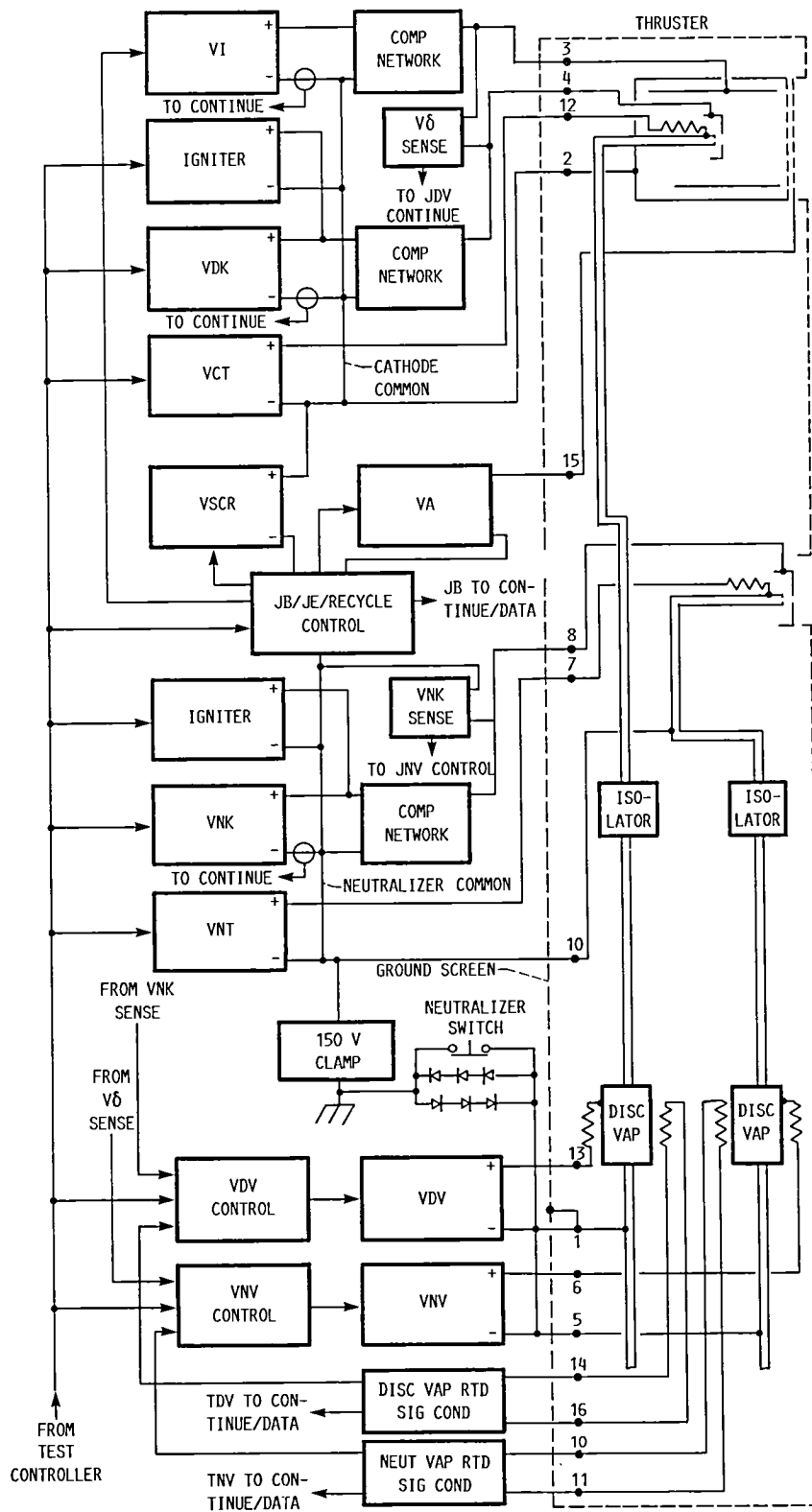
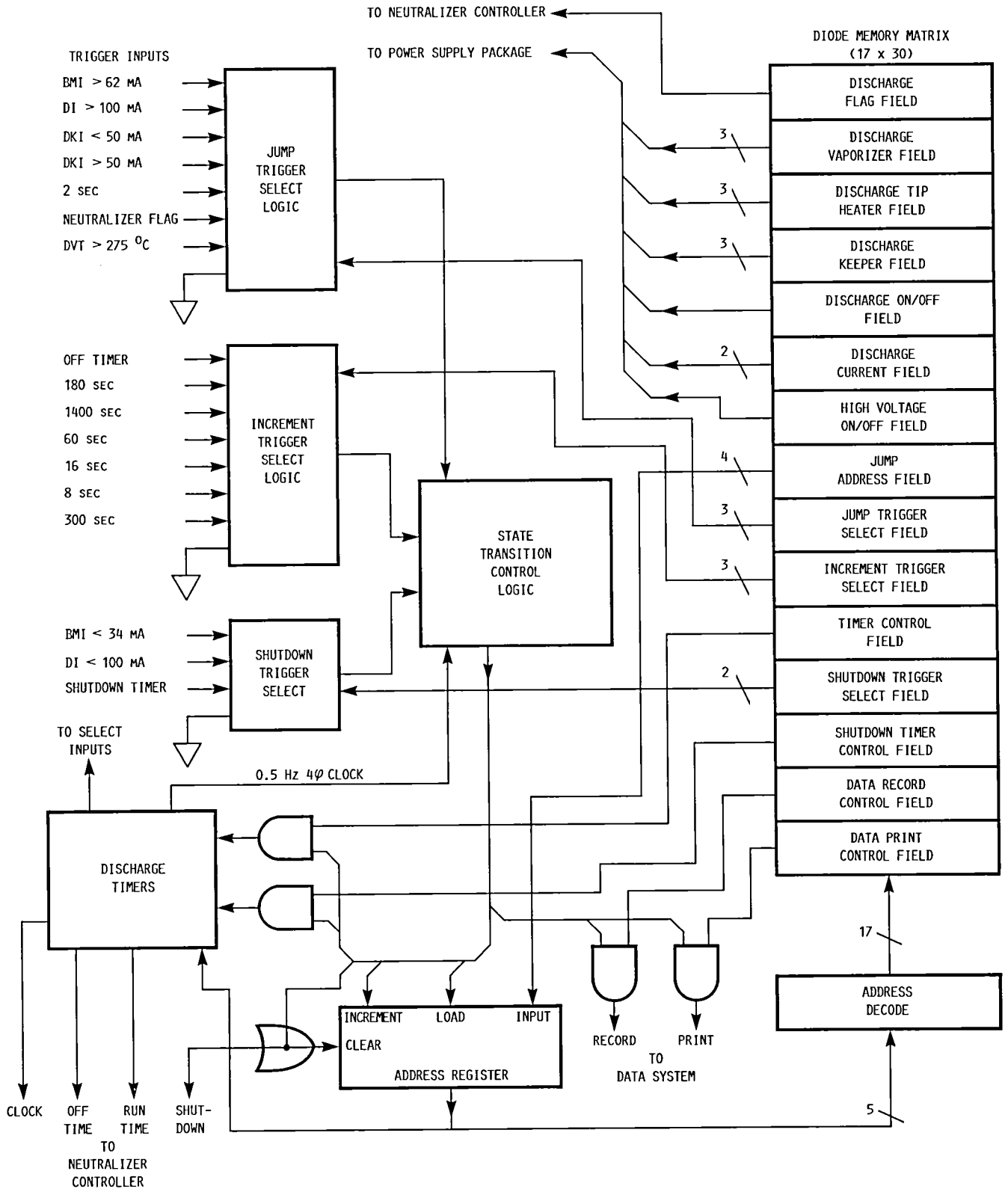
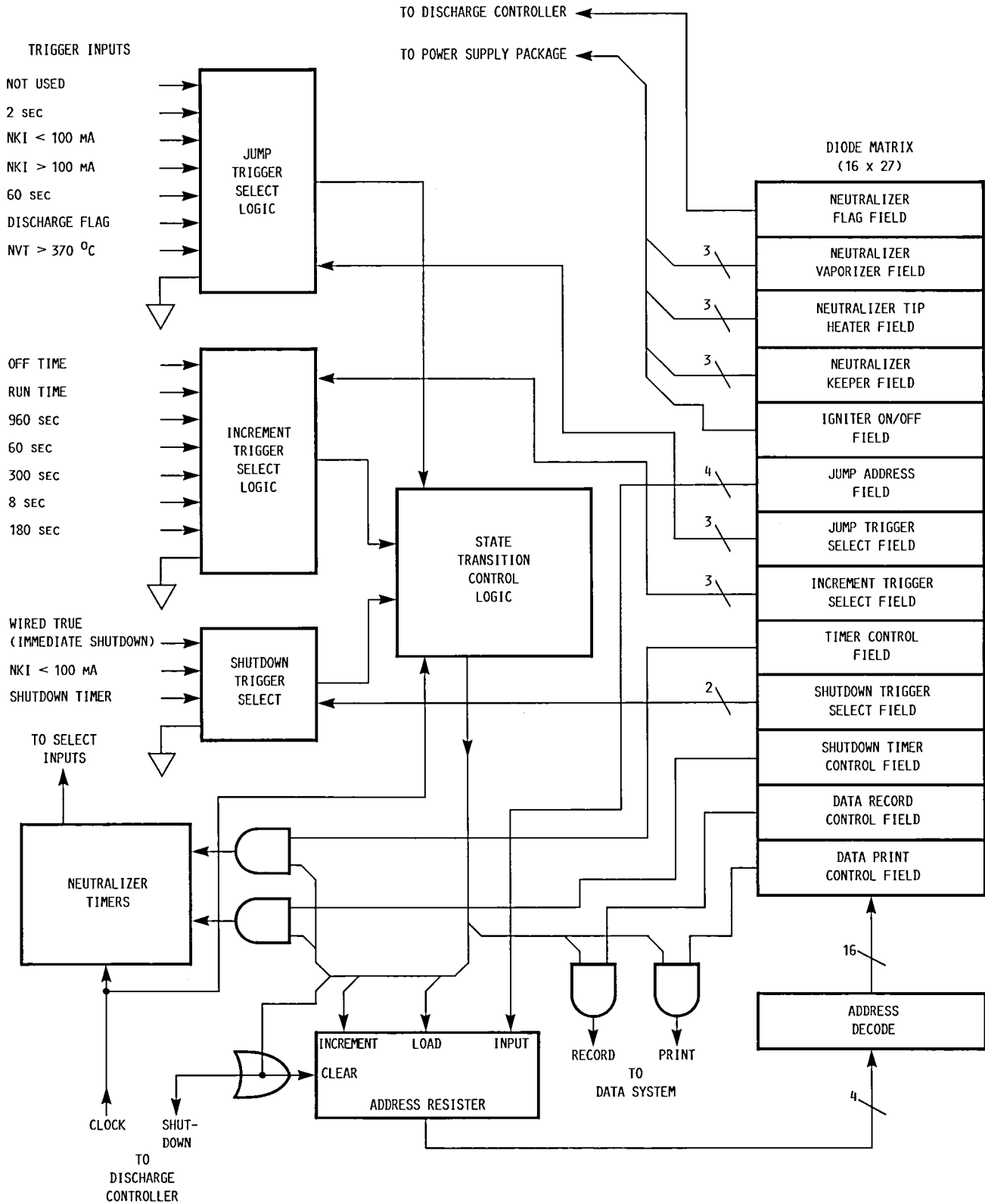

FIGURE 4. - POWER SUPPLY AND CONTROL SYSTEM CONFIGURATION.



(a)
 FIGURE 5. - DISCHARGE CONTROLLER CONCEPTUAL BLOCK DIAGRAM.



(b)

FIGURE 5. - CONCLUDED.

POWER SUPPLY	C_I INPUT CAPACITY, μF	R_I PARALLEL INPUT RESISTANCE, Ω	L_S SERIES INDUCTANCE, μH	R_S SERIES RESISTANCE, Ω	C_O OUTPUT CAPACITY, μF
NEUTRALIZER KEEPER	2.22	2700	2.2	1.42	----
DISCHARGE KEEPER	2.22	2700	7.0	6.07	----
DISCHARGE SUPPLY	----	----	11.5	4.1	0.94

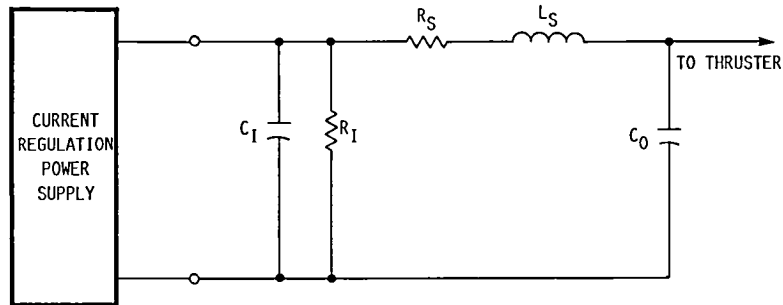

FIGURE 6. - DISCHARGE IMPEDANCE CONTROL NETWORKS.

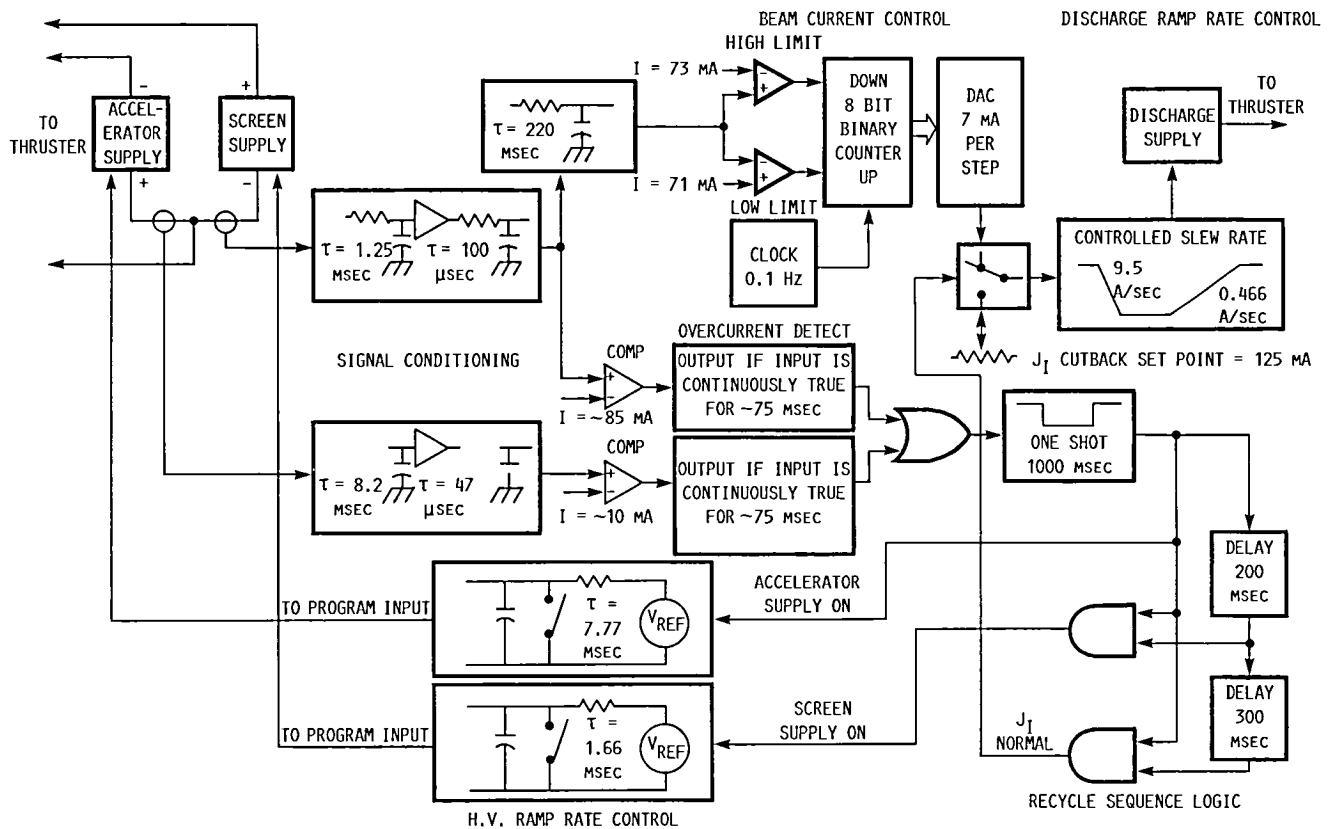

FIGURE 7. - RECYCLE AND BEAM CURRENT CONTROL.

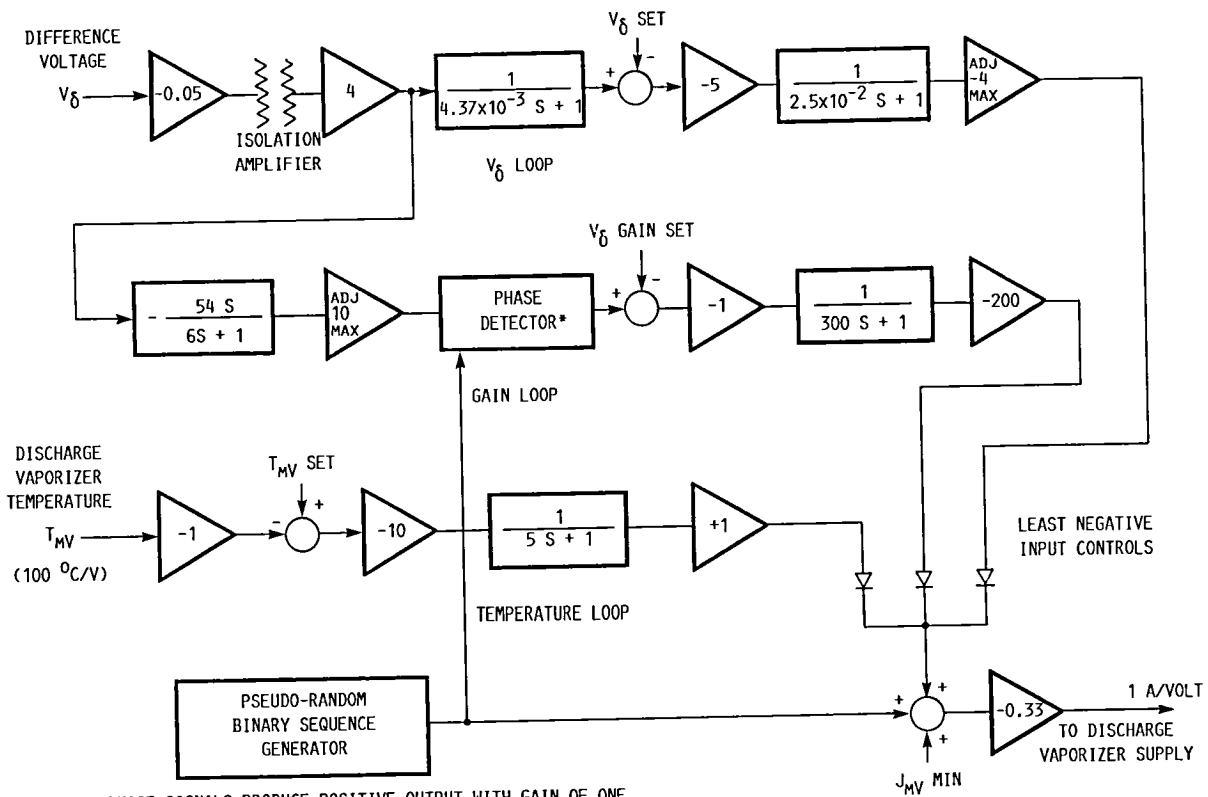

FIGURE 8. - DISCHARGE CHAMBER DIFFERENCE VOLTAGE CONTROLLER, BLOCK DIAGRAM.

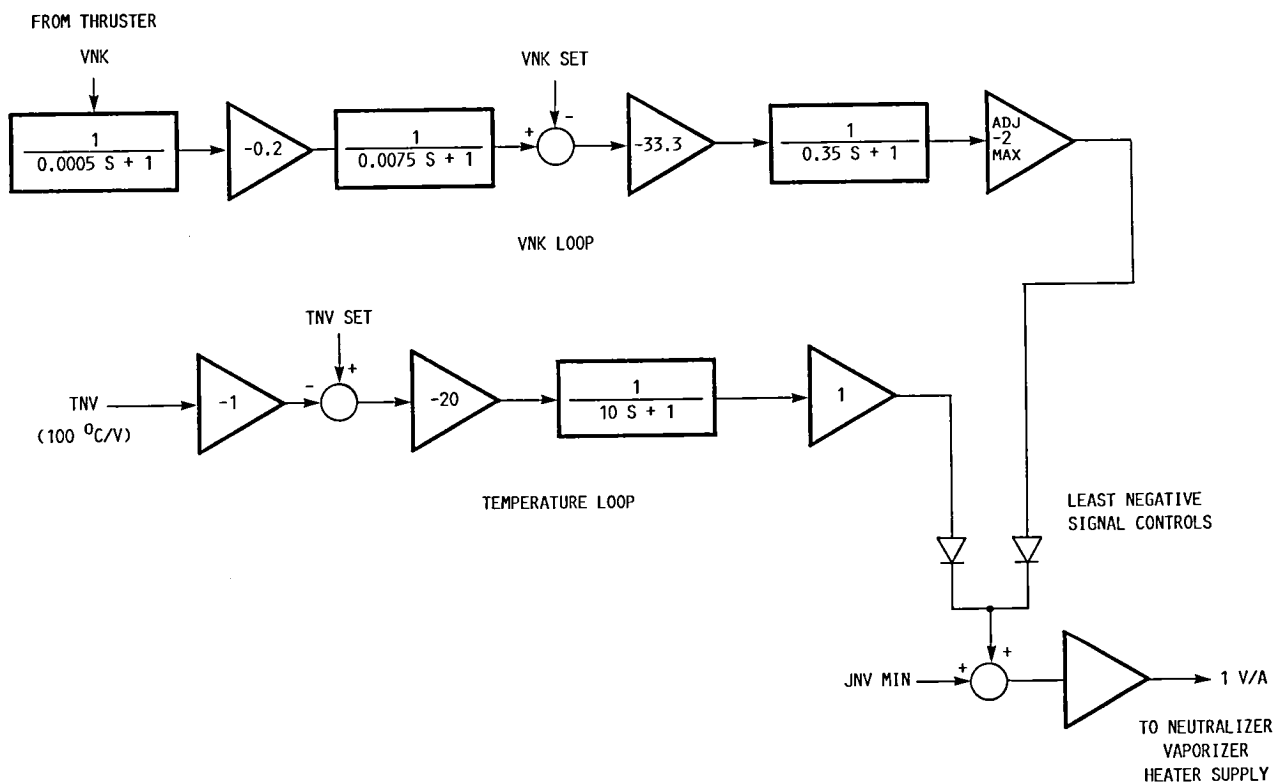

FIGURE 9. - NEUTRALIZER KEEPER VOLTAGE CONTROLLER BLOCK DIAGRAM.

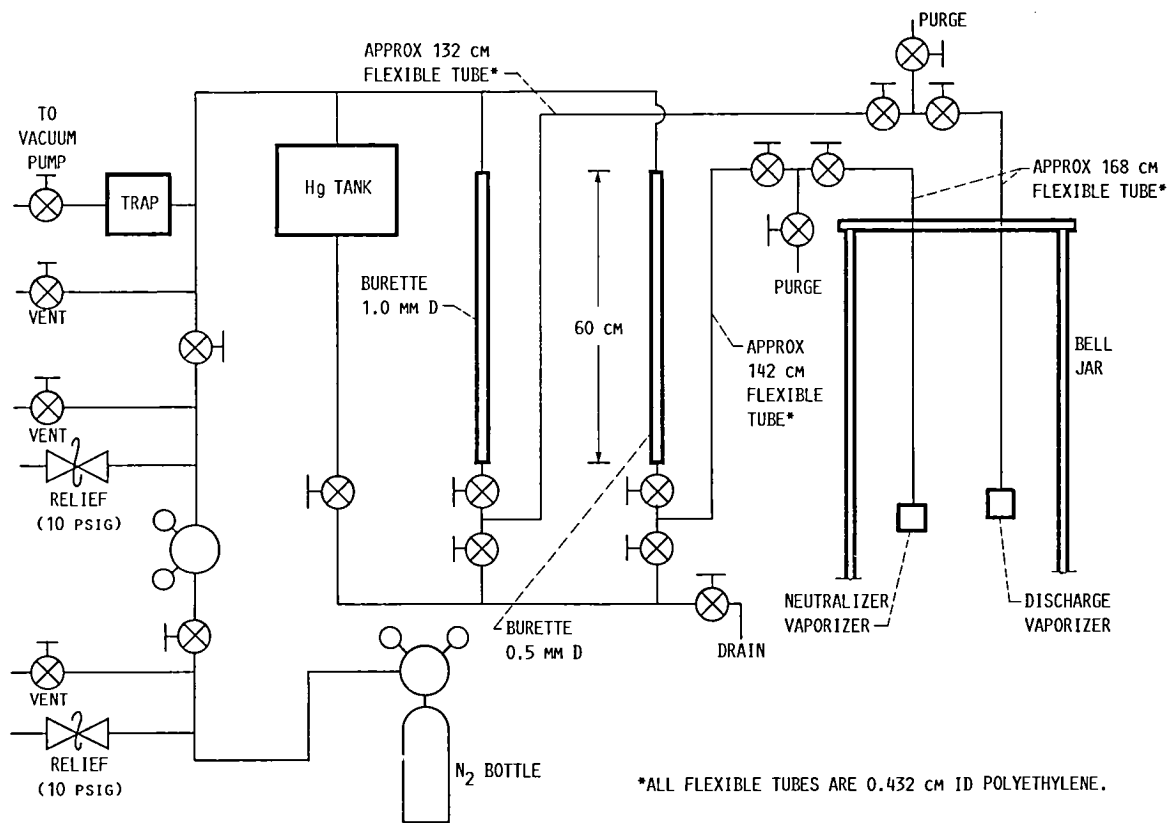

FIGURE 10. - MERCURY FEED SYSTEM.

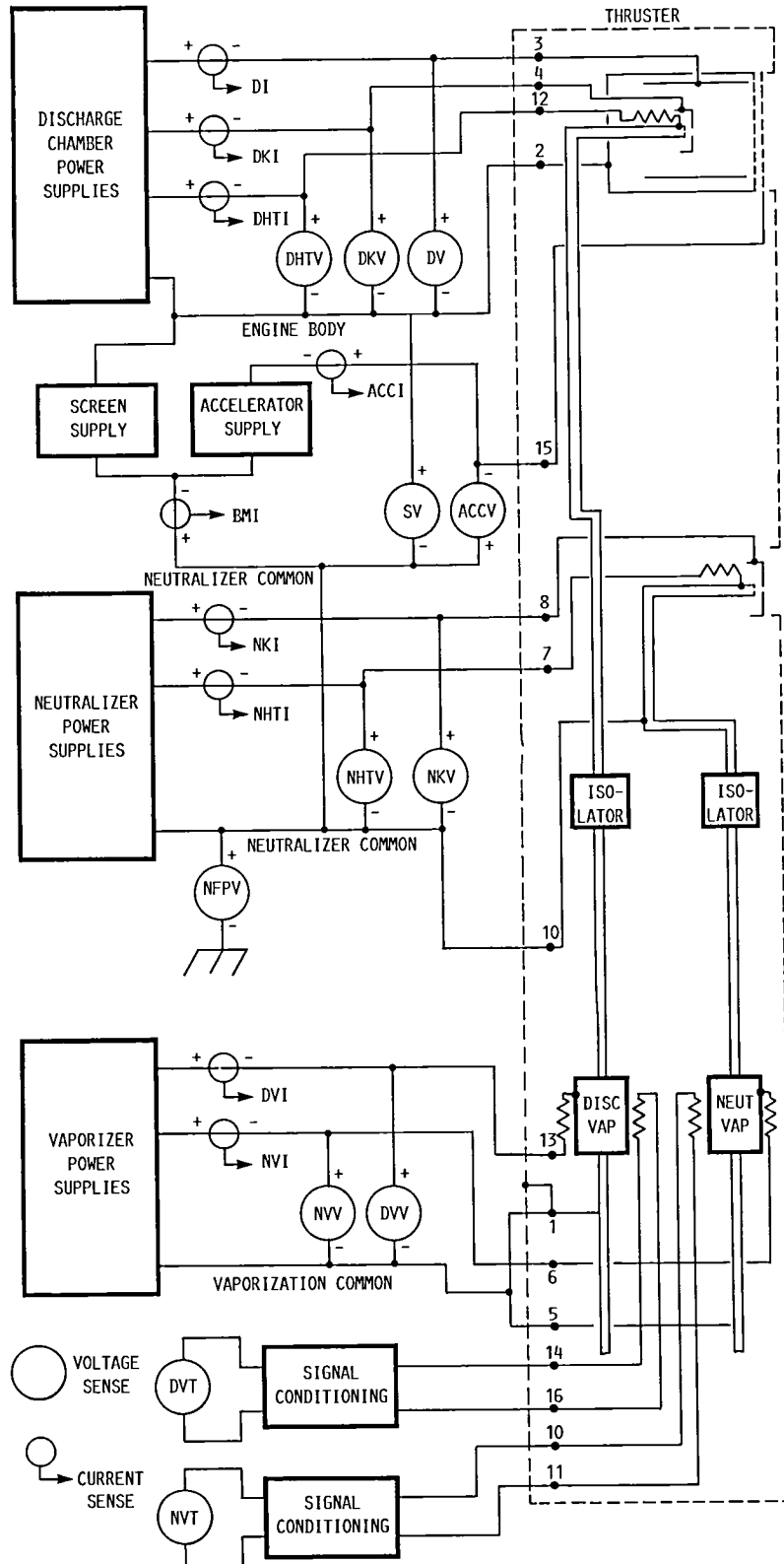

FIGURE 11. - THRUSTER MEASUREMENT DEFINITION.

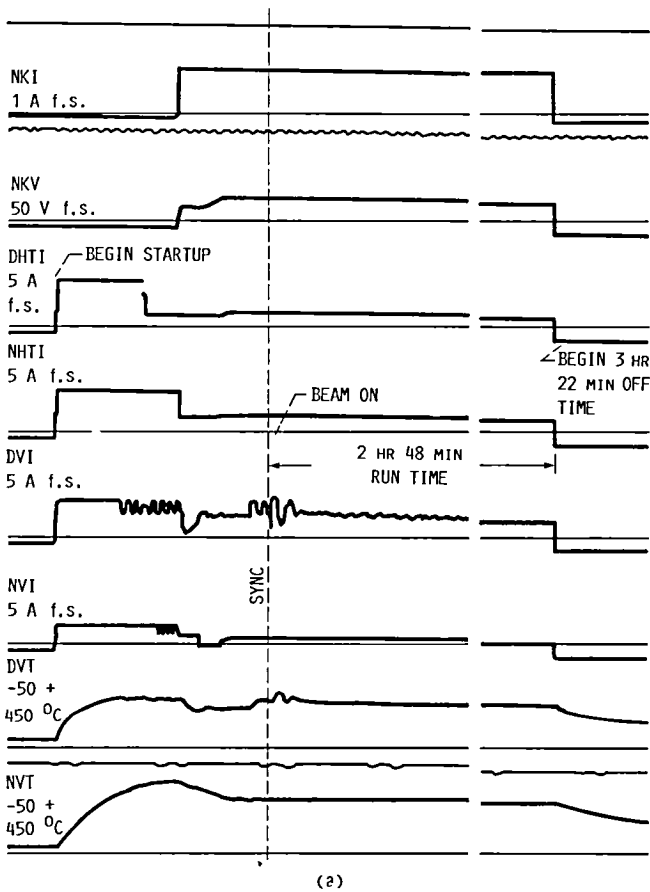

FIGURE 12. - TYPICAL STRIP CHART TRACES OF ONE CYCLE.

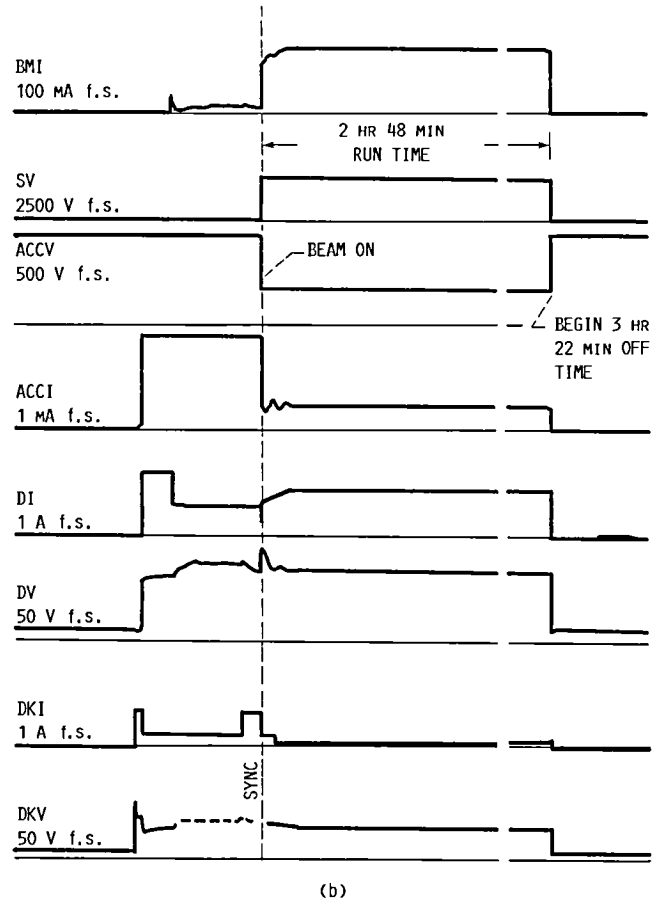
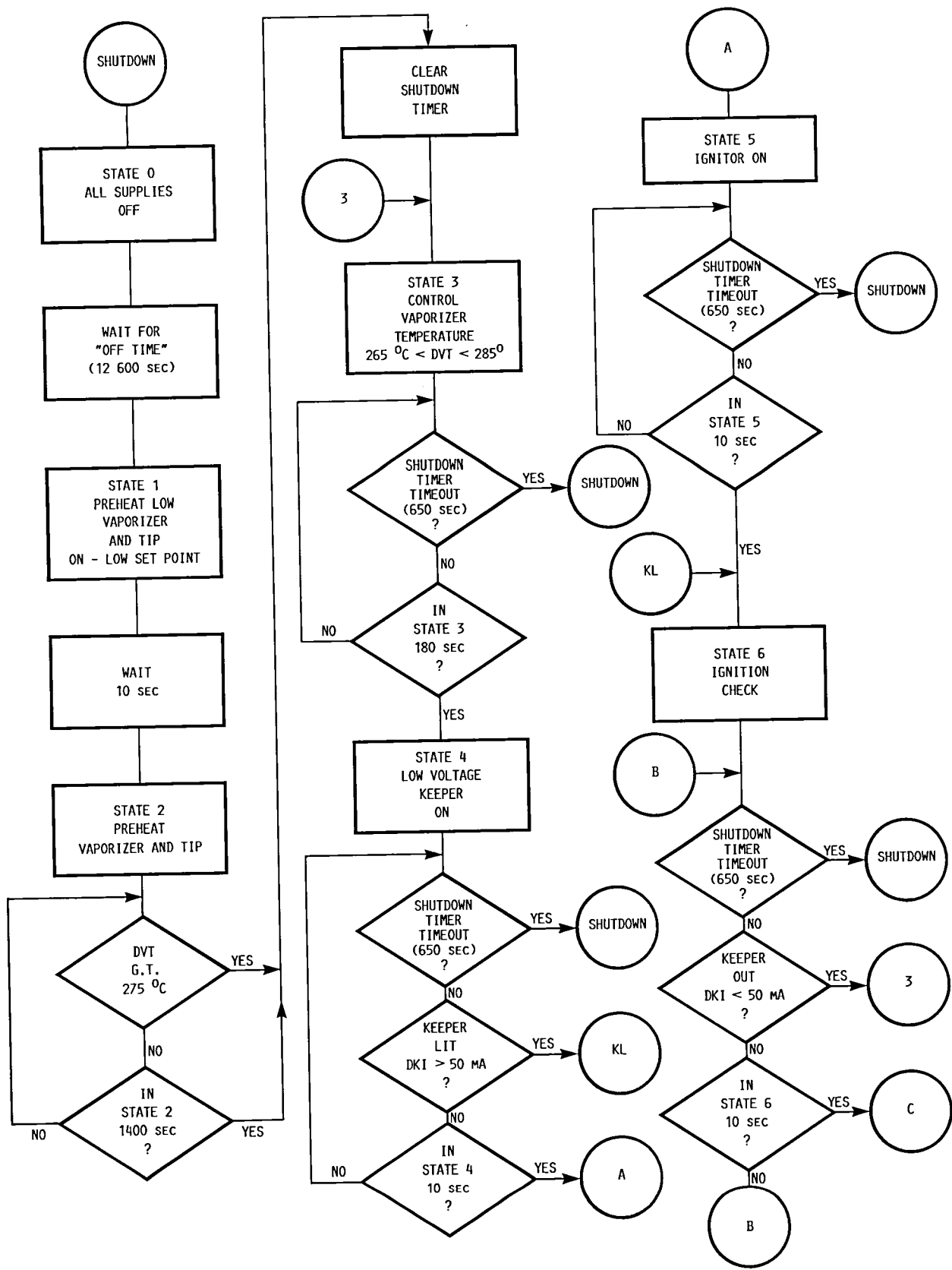
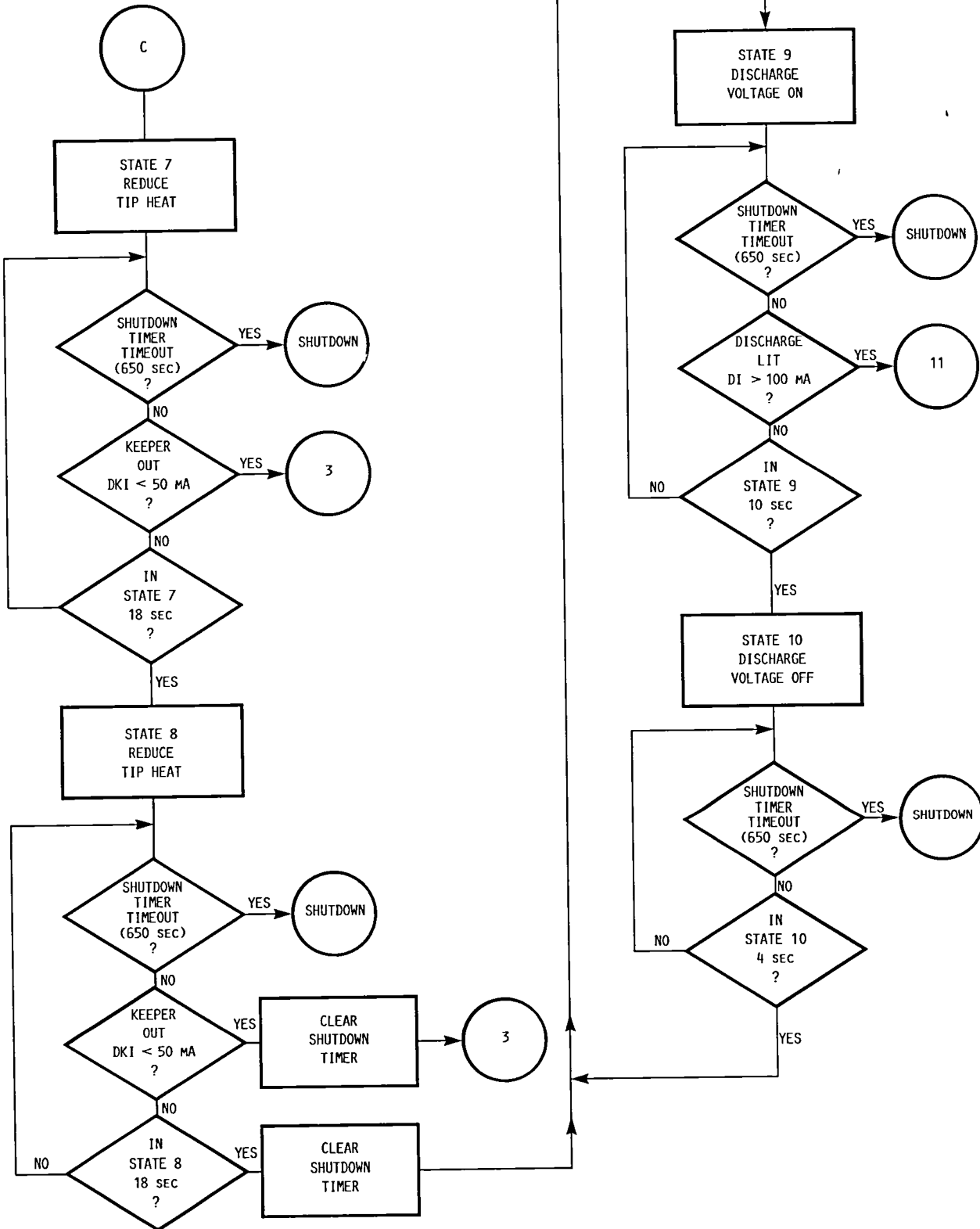

FIGURE 12. - CONCLUDED.



(a) SHEET 1 OF 3.

FIGURE 13. - DISCHARGE CONTROL LOGIC.



(b) SHEET 2 OF 3.
FIGURE 13. - CONTINUED.

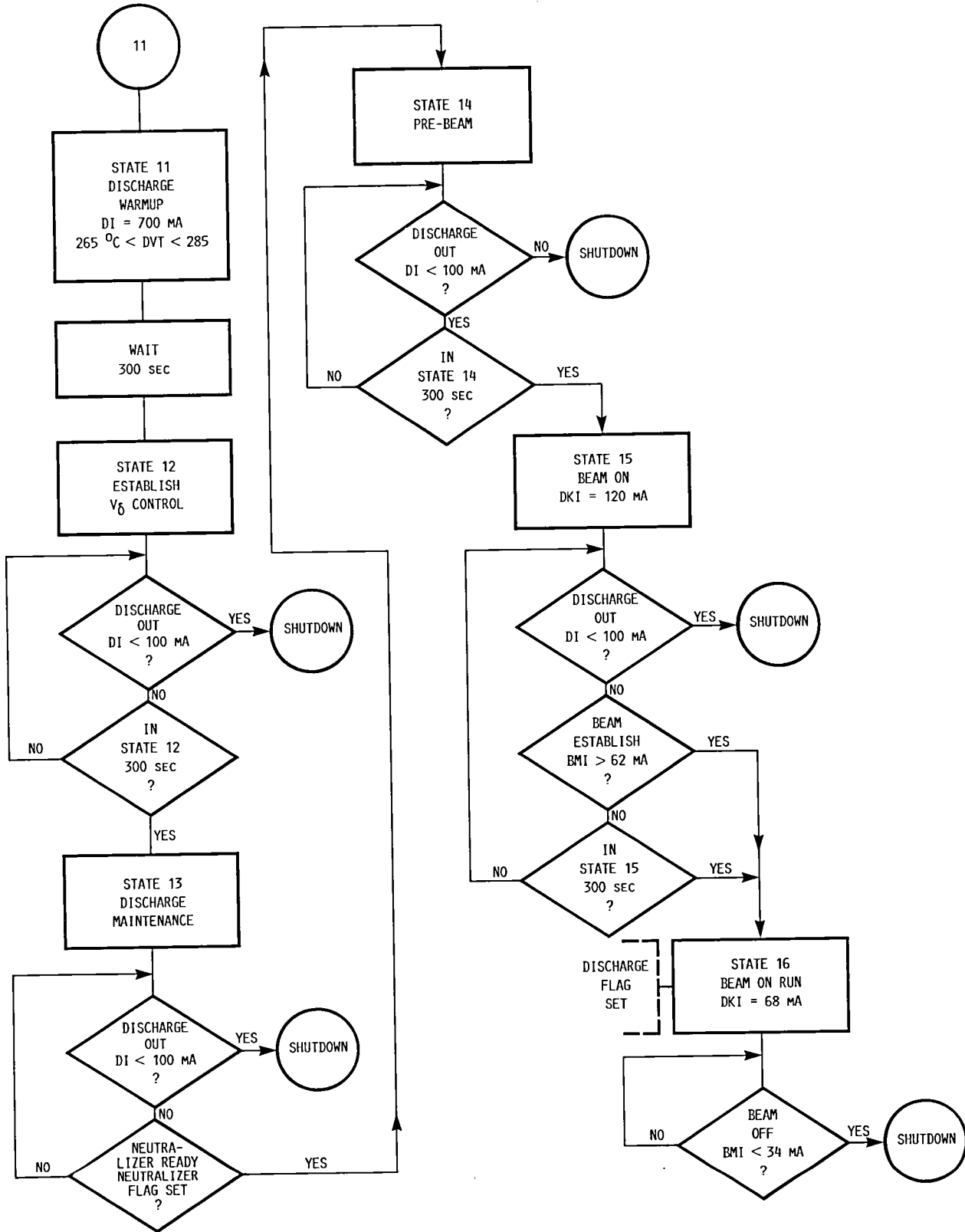

(c) SHEET 3 OF 3.
FIGURE 13. - CONCLUDED.

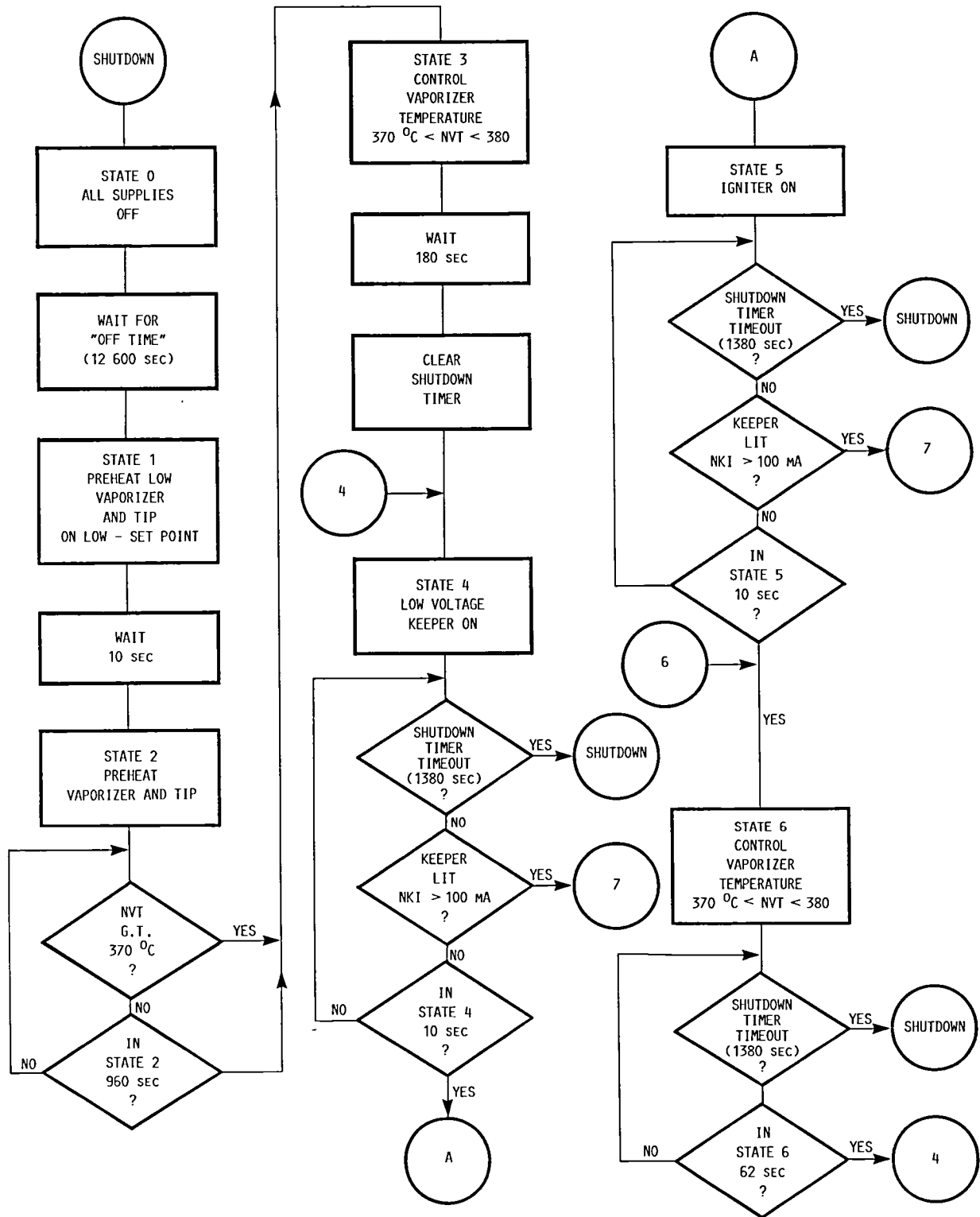

(a) SHEET 1 OF 3.

FIGURE 14. - NEUTRALIZER/RUN CONTROL LOGIC.

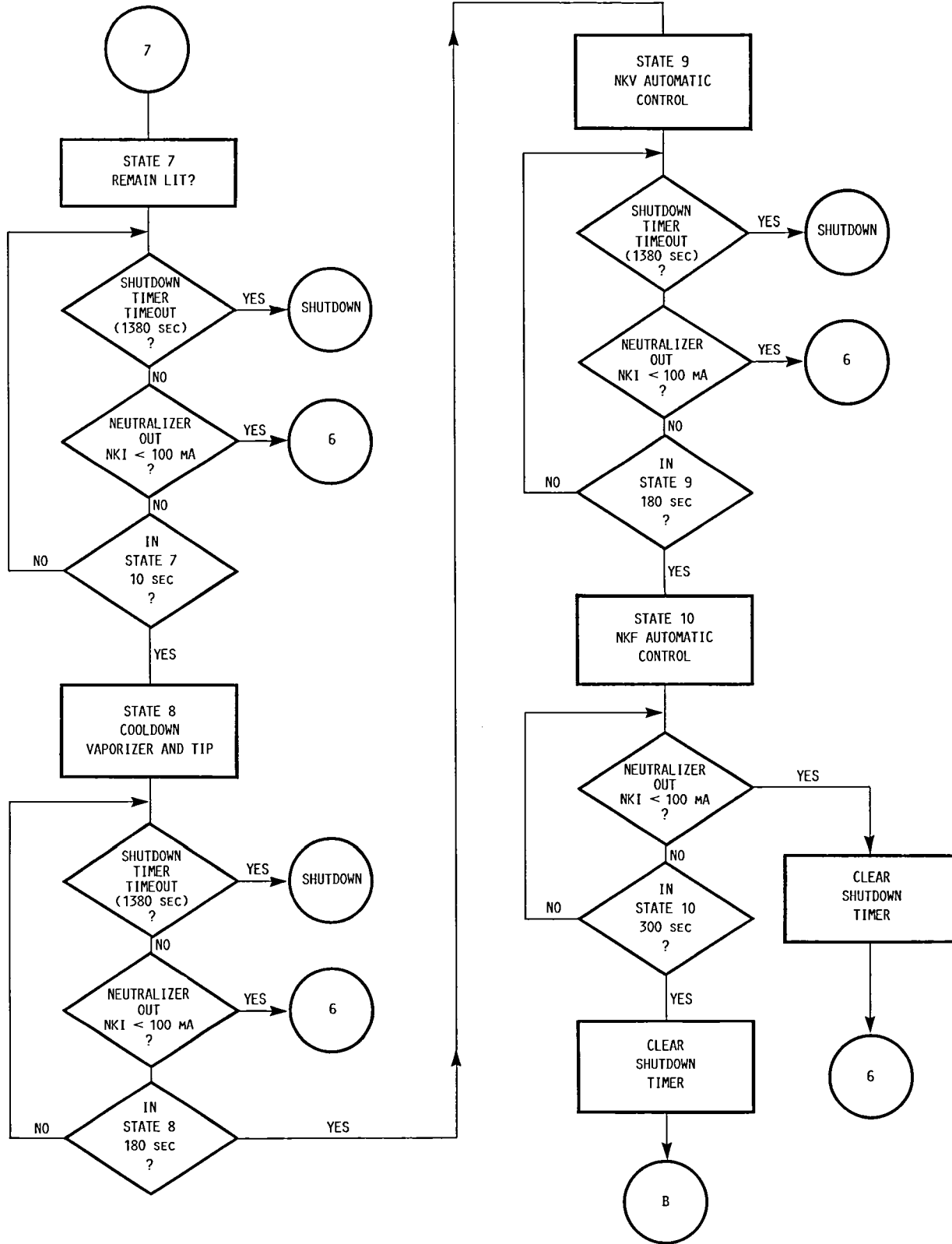

(b) SHEET 2 OF 3.
FIGURE 14. - CONTINUED.

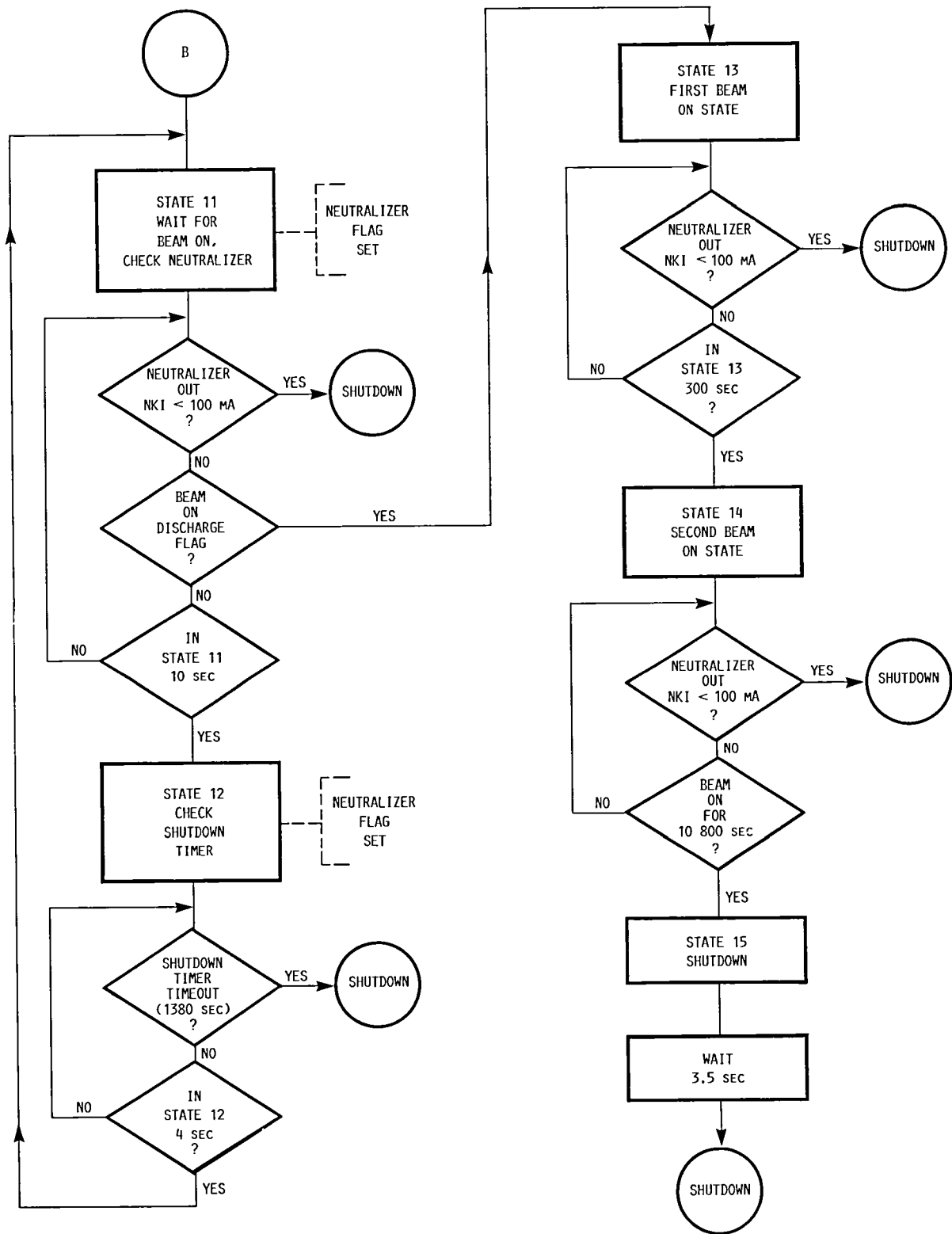

(c) SHEET 3 OF 3.
FIGURE 14. - CONCLUDED.

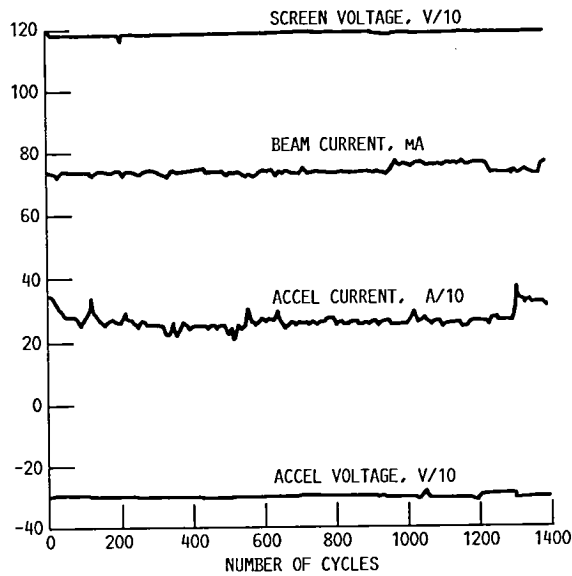

(a)

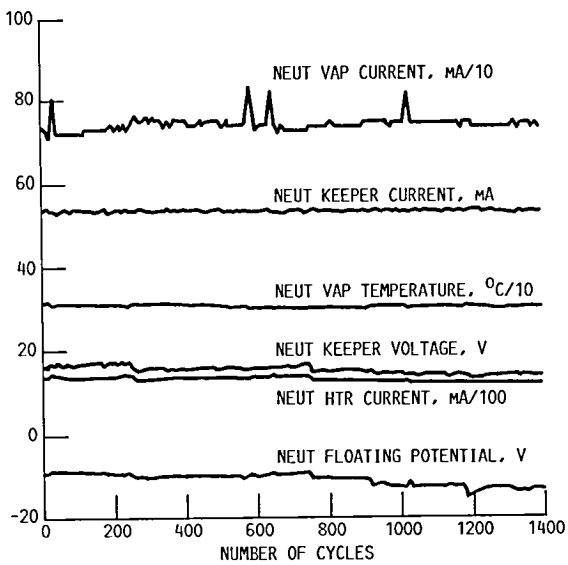

(b)

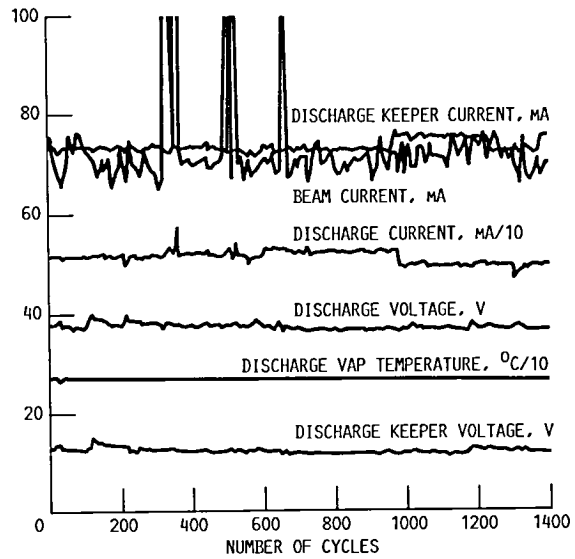

(c)

FIGURE 15. - 905 GROUND TEST THRUSTER DATA.



Report Documentation Page

1. Report No. NASA TM-100870		2. Government Accession No.		3. Recipient's Catalog No.	
4. Title and Subtitle A Cyclic Ground Test of an Ion Auxiliary Propulsion System: Description and Operational Considerations				5. Report Date June 1988	
				6. Performing Organization Code	
7. Author(s) Jerri S. Ling and Edward H. Kramer				8. Performing Organization Report No. E-3251	
				10. Work Unit No. 506-48-22	
9. Performing Organization Name and Address National Aeronautics and Space Administration Lewis Research Center Cleveland, Ohio 44135-3191				11. Contract or Grant No.	
				13. Type of Report and Period Covered Technical Memorandum	
12. Sponsoring Agency Name and Address National Aeronautics and Space Administration Washington, D.C. 20546-0001				14. Sponsoring Agency Code	
				15. Supplementary Notes	
16. Abstract <p>The Ion Auxiliary Propulsion System (IAPS) experiment is designed for launch on an Air Force Space Test Program satellite (NASA TM-78859 (AIAA Paper No. 78-647)). The primary objective of the experiment is to flight qualify the 8-cm mercury ion thruster system for stationkeeping applications. Secondary objectives are measuring the interactions between operating ion thruster systems and host spacecraft, and confirming the design performance of the thruster systems. Two complete 8-cm mercury ion thruster subsystems will be flown. One of these will be operated for 2557 on/off cycles and 7057 hr at full thrust. Tests are currently underway in support of the IAPS flight experiment. In this testing an IAPS thruster is being operated through a series of startup/run/shut-down cycles which simulate thruster operation during the planned flight experiment. A test facility description and operational considerations of this testing using an engineering model 8-cm thruster (S/N 905) is the subject of this paper. Final results of this test will be published at a later date when the ground test is concluded.</p>					
17. Key Words (Suggested by Author(s)) Auxiliary propulsion Attitude control Ion propulsion			18. Distribution Statement Unclassified - Unlimited Subject Category 20		
19. Security Classif. (of this report) Unclassified		20. Security Classif. (of this page) Unclassified		21. No of pages 52	22. Price* A04

National Aeronautics and
Space Administration

Lewis Research Center
Cleveland, Ohio 44135

Official Business
Penalty for Private Use \$300

SECOND CLASS MAIL

ADDRESS CORRECTION REQUESTED



Postage and Fees Paid
National Aeronautics and
Space Administration
NASA-451

NASA
