

NASA Contractor Report 4027

NASA-CR-4027 19880015248

Space Station Architectural Elements Model Study

T. C. Taylor, J. S. Spencer, C. J. Rocha,
E. Khan, E. Clifton, and C. Carr

JANUARY 1987

LIBRARY COPY

FEB 11 1987

LANGLEY RESEARCH CENTER
LIBRARY, NASA
HAMPTON, VIRGINIA

NASA



NF01836

NASA Contractor Report 4027

Space Station Architectural Elements Model Study

T. C. Taylor, J. S. Spencer, C. J. Rocha,
E. Khan, E. Clifton, and C. Carr

Taylor and Associates, Inc.
Wrightwood, California

Prepared for
Ames Research Center
under Purchase Order A211774C



National Aeronautics
and Space Administration

Scientific and Technical
Information Branch

1987

PREFACE

This is the final report on the SPACE STATION ARCHITECTURAL ELEMENTS MODEL STUDY for the Aero-Space Human Factors Division, NASA-Ames Research Center, Moffett Field CA 94035. The technical monitor is Marc M. Cohen, Mail Stop 239-2, Phone 415-694-5385.

This report was prepared by Thomas C. Taylor, Phone 619-249-6882 from material created by the author and independent consultants E. Khan, J.S. Spencer, C.J. Rocha, E. Clifton and C. Carr. The report includes research assistance and report preparation by A.S. Taylor.

The models called for in the contract were delivered in Dec 1985 at the NASA Research Review. The final report is expected to be available in the 3 1/2" magnetic disk format from the author or directly from NASA-Ames technical monitor via a technical exchange agreement with Taylor and Associates, Inc. All original drawings are to 1" = 1' - 0" scale. The photographs were taken by Richard Dowling of Space Media and a NASA-Ames Photographer.

Thomas C. Taylor
P.O. Box 1547
Wrightwood, CA 92397

Phone 619-249-6882

TABLE OF CONTENTS

<u>SECTION</u>	<u>PAGE</u>
SUMMARY	1
INTRODUCTION	2
OBJECTIVE	2
BACKGROUND TO OBJECTIVE	3
APPROACH	11
HUMAN FACTORS/HUMAN PRODUCTIVITY VARIABLES	11
NEUTRAL BODY POSTURE	14
ENGINEERING WORK STATION	15
NEUTRAL BODY POSITION REFINED	23
CREW WORKSTATION	23
PERSONAL WORK VOLUME	31
MODULE CONTROL STATION	37
CENTRAL BEAM DESIGNS	37
PRELIMINARY UTILITY ESTIMATE	42
TRIANGULAR BEAM ON CENTER	42
TRIANGULAR BEAM OFF CENTER	65
SQUARE BEAM ON CENTER	65
HEXAGONAL BEAM - SMALL	65
HEXAGONAL BEAM - LARGE	65
H BEAM - CENTER	65
HEXAGONAL BEAM - MEDIUM	65
COMMON MODULE APPLICATIONS	121
ENGINEERING WORKSTATION	121
BEAM MODELS	121
ISSUES	135
OBSERVATIONS	136
CONCLUSIONS	137
RECOMMENDATIONS	139
APPENDIX	
REFERENCES	
COSATI PAGE - 200 WORD ABSTRACT	

LIST OF FIGURES

PAGE

Figure 1	Recommended Evaluation Factor Example	13
Figure 2	Brand Griffin's Neutral Body Position	16
Figure 3	Neutral Body Position Computer Model	17
Figure 4	Workspere from NASA CR-3941	18
Figure 5	Workstation Rendering	19
Figure 6	Large Workstation	20
Figure 7	Space Station Application	21
Figure 8	Top View Large Workstation	22
Figure 9	Application of the Neutral Body Position Computer Model	24
Figure 10	Computer Front View with Arms Rotated	25
Figure 11	Computer Front View with Legs Rotated	26
Figure 12	Computer Side View with Arms Rotated	27
Figure 13	Computer Side View with Legs Rotated	28
Figure 14	Engineering Workstation Goal & Definition	29
Figure 15	Engineering Workstation Components	30
Figure 16	Compressed Transport Unit	32
Figure 17	Engineering Workstation Ergonomics	33
Figure 18	Prime Work Area Workstation	34
Figure 19	Top View - Engineering Workstation	35
Figure 20	Middeck Sized Equipment	36
Figure 21	Module Control Station	38
Figure 22	Module Control Station Details	39
Figure 23	Original Triangular Central Beam Concept	40
Figure 24	Triangular Central Beam in Module	41
Figure 25	Six Beam Configurations	43
Figure 26	Assumed Utilities	44
Figure 27	Hatch Assumption	45
Figure 28	Utility Volume Estimate	46
Figure 29	ECLS Volume Estimate (1 of 3)	47
Figure 30	ECLS Volume Estimate (2 of 3)	48
Figure 31	ECLS Volume Estimate (3 of 3)	49
Figure 32	Triangular Beam - On Center	50
Figure 33	Equilateral Triangular Beam - On Center	51
Figure 34	On Center Triangular Beam Application (1 of 6)	56
Figure 35	On Center Triangular Beam Application (2 of 6)	57
Figure 36	On Center Triangular Beam Application (3 of 6)	58
Figure 37	On Center Triangular Beam Application (4 of 6)	59
Figure 38	On Center Triangular Beam Application (5 of 6)	60
Figure 39	On Center Triangular Beam Application (6 of 6)	61
Figure 40	On Center Triangular Beam Renderings	62
Figure 41	On Center Triangular Beam - Long Submodule System	63
Figure 42	Interior Assumptions	64
Figure 43	Double Submodule/Half Hook Up Concept	72
Figure 44	High Density Pack	73
Figure 45	Triangular Off Center Beam - High Density	74
Figure 46	Maintenance and Changeout	75
Figure 47	Triangular - Off Center	78

LIST OF FIGURES (CONT.)

PAGE

Figure 48 Square Beam Configuration (1 of 4)	79
Figure 49 Square Beam Configuration (2 of 4)	80
Figure 50 Square Beam Configuration (3 of 4)	81
Figure 51 Square Beam Configuration (4 of 4)	82
Figure 52 Hex Beam - Small Diameter	83
Figure 53 Hex Beam - Small Diameter Sizing	94
Figure 54 Hex Beam - Expanded Diameter	95
Figure 55 H Beam Concept	100
Figure 56 Dense Pack Triangular	101
Figure 57 Dense Pack - Expanded	120
Figure 58 Utility Transition - Original Common Module	122
Figure 59 Transition Details	123
Figure 60 Racetrack - Minimum Crew Circulation Route	124
Figure 61 Engineering Workstation Model	125
Figure 62 3' x 3' x 7' Submodule	126
Figure 63 Beam Models - Example Drawing	127
Figure 64 Triangular Beam Model Details	128
Figure 65 Triangular Beam Model Example Fabrication Details	129
Figure 66 Triangular Beam Model - Model Materials Prelim	130
Figure 67 Interior Layout Comparisons	131
Figure 68 Volume and Packing Details	132
Figure 69 Evaluation Criteria on Interior Configurations	134
Figure 70 Comparison of Negative Volume	138

LIST OF PHOTOGRAPHS

PAGE

Photograph-1	NASA Furnished Scale Models	5
Photograph-2	The 50 Inch Diameter Circular Hatch With 49.4 % Male	7
Photograph-3	Hatch with Sub Module, Spacelab Racks and Scaled Human	9
Photograph-4	Triangular Beam Insert for the Center of the Module	53
Photograph-5	Triangular Beam Insert With Human Form	55
Photograph-6	Triangular Beam Loaded with Submodules	67
Photograph-7	Triangular Beam Loaded Longitudinally With Submodules	69
Photograph-8	Triangular Beam-Off Center in the Module	71
Photograph-9	Triangular Beam with Expanded Submodule	77
Photograph-10	Square Beam-On the Center in the Module	85
Photograph-11	Square Beam and Submodule Close Up	87
Photograph-12	Hexagonal Beam with Centerline Translation	89
Photograph-13	Hexagonal Beam with Centerline Logistics	91
Photograph-14	Hexagonal Beam with Human Logistics Volume	93
Photograph-15	Larger Hexagonal Beam with Human Form	97
Photograph-16	Larger Hexagonal Beam with Expanded Submodules	99
Photograph-17	H Beam Concept Located in the Center	103
Photograph-18	H Beam Concept with Human Forms	105
Photograph-19	Hexagonal Beam Concept with Triangular Core	107
Photograph-20	Hexagonal Beam Concept with Submodule Changeout	109
Photograph-21	Hexagonal Beam Concept with Submodule Expanded	111
Photograph-22	Hexagonal Beam Concept with Human Like Form	113
Photograph-23	Hexagonal Beam Concept with Variable Sized Submodules	115
Photograph-24	Hexagonal Beam Concept with Gaps Between Submodules	117
Photograph-25	Hexagonal Beam Concept with Oversized Submodules	119

SUMMARY

The goal of this contract is to develop, amplify, refine and resolve two ideas presented in a contractor report entitled SPACE STATION ELEMENTS AND ISSUES DEFINITION STUDY, by Taylor and Associates, Inc. in 1985, NASA CR 3941. This follow-on study focuses on these two concepts, the central beam and an engineering workstation for further development and later scale modeling in a NASA furnished scale model of the Space Station Common Module Shell.

The Engineering Workstation is an evolution of the worksphere and work pod idea definition from the previous contract. Several types of workstations will be required for the Space Station. The scope of the workstations will range from a simple personal workstation with individual human productivity tools and potentially personal volume, communications and entertainment considerations to a complex module and station control workstation. The complex end of the workstation functional spectrum may be a full up module control station capable of simultaneous use by two crewmembers and capable of controlling the module and station from each module location.

The architectural researchers constructed seven beam configuration models, each one a straight module section in length. The following analysis suggests a methodology for identifying, selecting and implementing a design criteria for evaluating the beam sections. The goal of these criteria is a prototype evaluation tool which is adaptable to several different kinds of Space Station Interior Architecture and flexible enough to be user modified.

In both of the above concept developments, the architectural researchers make two assumptions. First, they assume a 50 inch circular hatch. Second, space station operating organizations will perform updating of interior submodules on the ground and transport the submodules to the station with the logistics system. The anthropometrics used in both developments include an expansion of the work on THE INFLUENCE OF ZERO-G AND ACCELERATION ON THE HUMAN FACTORS OF SPACECRAFT DESIGN by Brand Griffin in 1978.

INTRODUCTION

The interior of the Space Station is the part of the project in which human productivity and innovation will occur. It is a unique volume and is to be continuously inhabited in zero gravity. This study presents two concepts to reflect this new environment. The concept suggestions and recommendations are only the very beginning of the process leading to a fully manned Space Station.

One concept is the Engineering Workstation designed to assist the crewmember as an orbital desk and each individual module as a larger separate module control station. The other is a central beam concept based on a triangular cross-section. Seven variations of the beam concept plus one engineering workstation were built as scale models in a NASA furnished 1" = 12" clear plastic model of the Common Module.

OBJECTIVE

The objective is to explore and analyze the interaction of major utilities distribution, generic workstation and spatial composition of the module interior. The goal of the contract is to develop, amplify, refine and resolve two ideas presented in a previous contract. The final result is to be 1" = 12" scale models approximately one 9 foot segment long of each beam concept and one workstation for use in the NASA furnished Common Module clear plastic models.

The crewstation and experiment station orbital experience to date indicates a wide range of different functions and types of workstations will be required in the Space Station. The surface based society has evolved since the Skylab period to ergonomically designed individual human productivity stations capable of a wide variety of functions. In the next eight years, the Engineering Workstation will emerge as a surface human productivity tool within the economic reach of most business and engineering individuals. A similar unit is anticipated in orbit for each crewmember. Each crewmember is expected to define some special equipment in addition to the standard equipment. The final result is to be a scaled model of the Engineering Workstation for use in the NASA furnished Common Module model. The output is to be inquiry by design derived evaluation criteria. The Evaluation Criteria is expected to be flexible enough to be used by different disciplines within the Space Station Community.

The central beam in rectangular form has been suggested in a NASA-JSC contractor study and a high fidelity mock-up exists at NASA-JSC. Other interior designs have also been suggested by a variety of organizations including the Phase B Space Station Contractors and international participants. The goal of this study is to investigate the central beam concept beyond the rectangular cross-section and determine the potential value of each to the Space Station program. Each of seven different central beam configurations are explored in the first half of the study and to be modeled in the last half of the effort. These include:

- 1. TRIANGULAR BEAM LOCATED ON CENTER OF MODULE**
- 2. TRIANGULAR BEAM LOCATED OFF CENTER**
- 3. SQUARE BEAM ON CENTER**
- 4. HEXAGONAL BEAM - SMALLER THAN 4 FEET**

5. HEXAGONAL BEAM - LARGER THAN 4 FEET

6. H BEAM - LOCATED IN THE CENTER

7. HEXAGONAL BEAM - MEDIUM

The final result of the contract is to be an 8.8 inch long model section of each beam configuration to be used to evaluate and determine its value in further research.

The purpose of the study is to bring the ideas presented in the previous study from the realm of philosophy and abstraction up to a level of tangible design schematics. The contractor work is to be focused on the NASA Space Station Program Phase B Definition Study Reference Configuration as defined at the start of the contract.

BACKGROUND TO OBJECTIVE

SEVERE AND HOSTILE ENVIRONMENT EXPERIENCE

The impact of remoteness on the individual is difficult to assess or even to comprehend until it is experienced. The author's experience includes 1 year in remote jungle environments in Southeast Asia and 3 years at Prudhoe Bay on the Alaskan North Slope. Additional subcontractor experience includes design work on Antarctic camps, commercial industry facilities, science facilities in high altitudes, high tech labs and undersea laboratories. John Spencer of Design Science, an interior human factors firm in Los Angeles, has contributed to the interior design of a cold undersea lab in fifty feet of water and science facilities in Antarctic. Eyoub Khan of the Conceptual Design Group, an architectural and planning firm in Irvine, CA, has contributed to industrial and commercial projects and work on this project included three central beam designs and most of the renderings. Ethan Clifton, an architect in San Francisco, brings experience on complex Earth based science related projects and contributed one central beam concept.

The remoteness impact on each person from long duration missions in orbit can be partly understood by studying surface antilogs. In Alaska, noticeable differences in human performance were experienced in 90 day tours and the individual seemed to be the last to recognize the degraded ability. Solutions included keeping busy, creating a comfortable (personal and private) space and special attention to specific human factors/human productivity variables within the work and non-work environment. The effect of the isolation seemed to be greater on self motivated college educated technical staff than on the sour dough union labor force with experience in other remote camps. The full impact of the remoteness of orbital duty will not be fully understood until the station is in operation. It may require flexibility in the human factor/human productivity interior design in orbit.

In a remote base on the surface, personal time and personal volume become very valuable to the human involved. In a long duration tour the individual seems to require the personal time as a mental rejuvenation period. The methods of utilizing this time vary with the individual. The author's personal experience includes 3 years in the Prudhoe Bay Alaska Construction Camps with tours ranging from 4 to 13 weeks - 91 days. The volume in which this personal time is enjoyed is also important. The more personal and individual the volume is, the more efficient the time seems to be for rejuvenation. Experience in Alaskan

COMMON MODULE SCALED MODEL

Photograph-1 is the full Common Module anticipated at the time of the NASA Contract. The scale model is at a scale of 1" = 1' - 0". The fabrication took place prior to the final decisions on the NASA Space Station IOC configuration. It includes 3 each cylindrical sections 8.84 inches long (8' - 10+" long) and 13.38 inches (13' - 4 1/2" or 160.5 inches) in diameter. One 12" (12' - 0") radial port segment and two each of an elliptical end cap with an offset hatch and two of the conical end cap with a center hatch. Shown on the facing page is the elliptical end cap. The flanges are bolted together to produce the full up Common Module. The common module shown is 47.32 feet long to scale and has an inside diameter of 160.5 inches or approximately 5.5 inches less to scale than the anticipated IOC Common Module. The hatches were assumed to be 50 inches in diameter and D shaped. The models were furnished by the technical monitor at NASA- Ames Research Center.

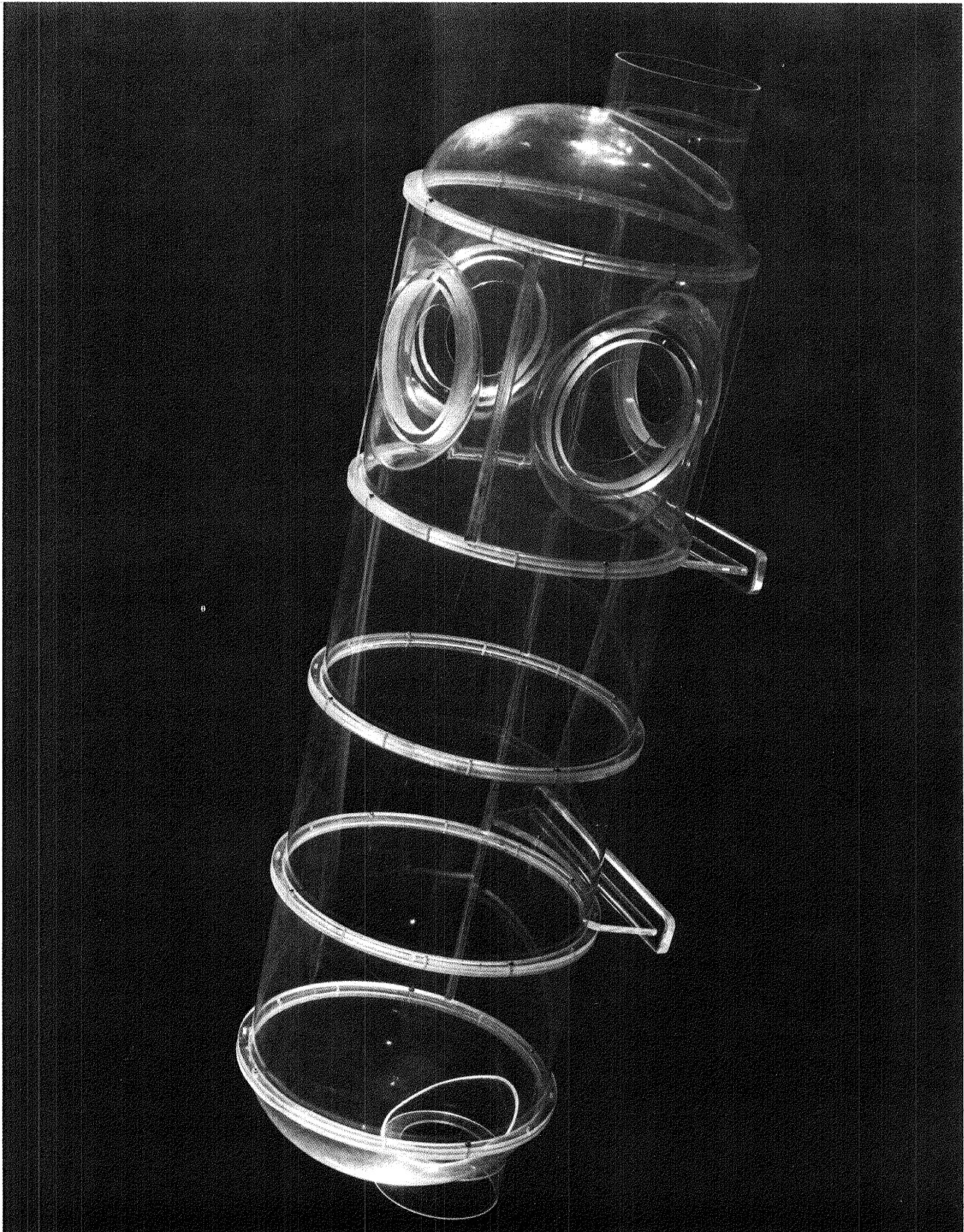

Photograph-1 NASA Furnished Scale Models

ASSUMED 50 INCH DIAMETER HATCH

Photograph-2 is the 50 inch diameter hatch assumed in this contract and used throughout for logistics and size of submodule decisions. The small three dimensional human figure is scaled at 5.75 inches standing height with shoes. Assuming 1 inch shoes, this translates to a 5' - 8" (68") standing height male human. The Henry Dreyfuss Associates, Humanscale 1/2/3, published by The MIT Press (1985), standing height for a 50% percentile U.S. Male is 68.8 inches and for a 97.5% percentile U.S. Female is 68.5 inches.

This means the human figure used represents a 49.4% percentile U.S. Male or a 96.8% percentile U.S. Female.

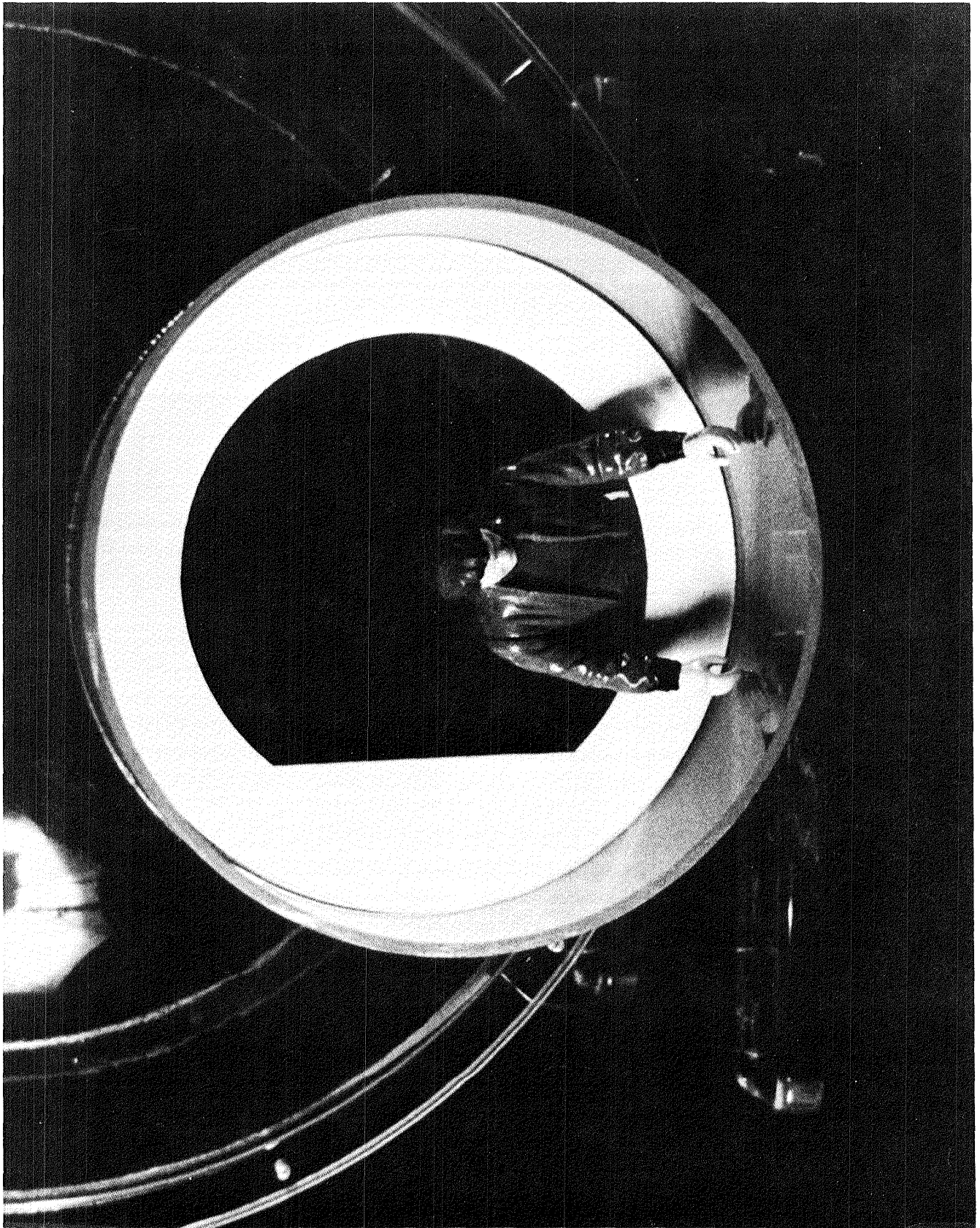

Photograph-2 The 50 Inch Diameter Circular Hatch With 49.4 % Male

LOGISTICS AT HATCH

Photograph-3 contains the scaled 3' x 3' x 7' submodule chosen to pass through the 50 inch circular hatch. The single Spacelab Rack and double Spacelab rack are also shown. The single rack would fit through the hatch opening.

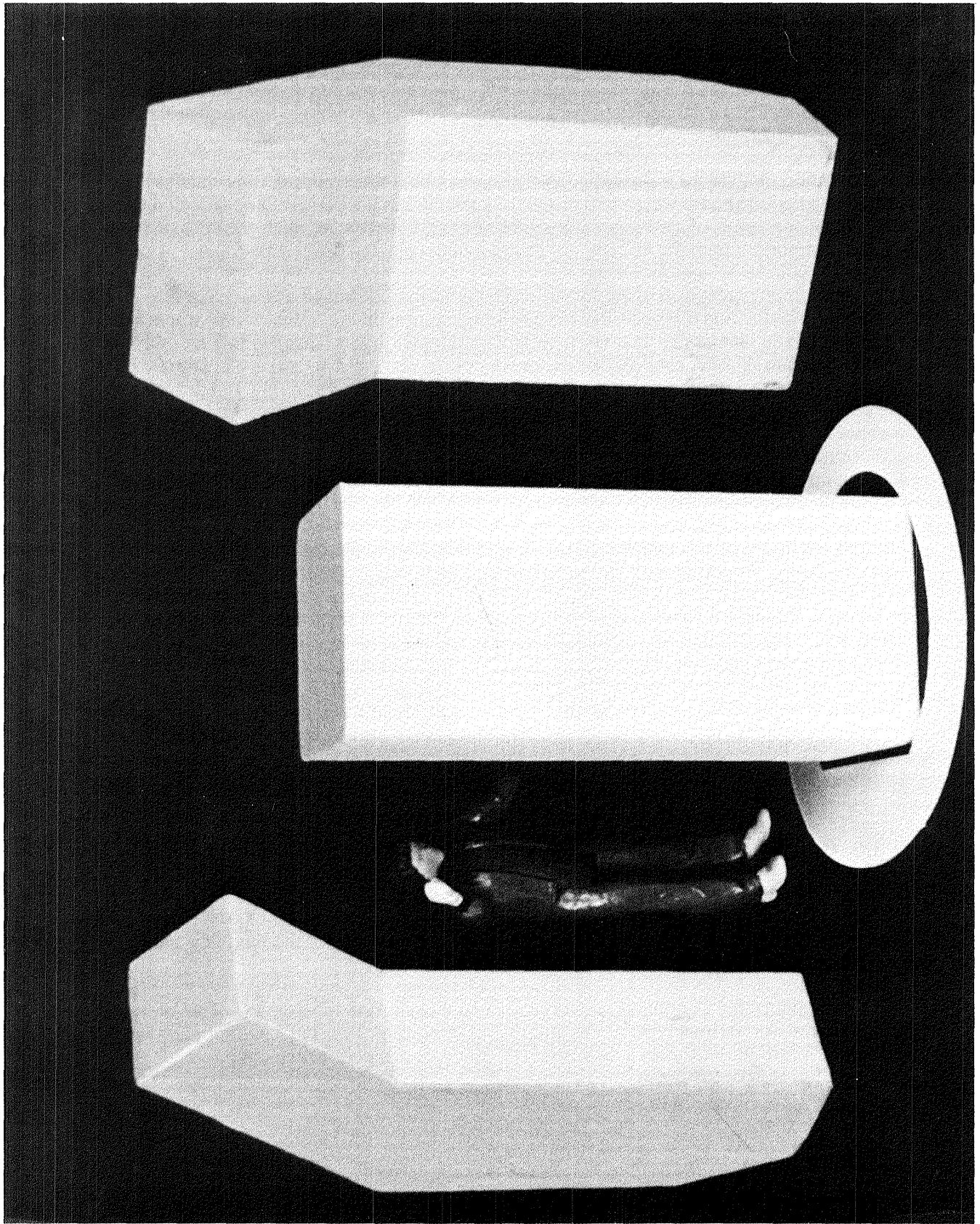

Photograph-3 Hatch with Sub Module, Spacelab Racks and Scaled Human

Construction camps indicates a wide range of personalization.¹ The personal aspect or the individual human view of the volume and the hardware involved is important and not presently emphasized in situations where it should be a strongly weighted evaluation criteria. Sleep quarters is a good example. It is a personal volume and the human factors of the individual and a capability to personalize the volume should get the emphasis in the design and utilization.

An evaluation method for a sleep quarters where personal preference is important to the human adaptation should weigh strongly the social and human perception evaluation criteria (Human Acceptance). A commercial volume where efficiency and other technical aspects are more important than the human factors would be weighted differently.

The total human perception of a remote hostile environment isn't all abstract human emotions. The technical aspects of life sustaining equipment quickly becomes important and is perceived differently than work tools for example. In one camp with a chronic fire safety hazard in Alaska, everybody slept with parkas, survival bag and arctic boots within arms reach in the dark plus there was a dedicated large bulldozer running in a nearby shed to cut the camp in half in case of fire. Living in the other camp with overhead sprinklers was not as life threatening. The collective reactions at each camp were surprisingly consistent - anxiety at the safety hazard camp, and a much more relaxed atmosphere at the safer camp. The technical aspects of the equipment and interior designs in orbit should employ an evaluation criteria which is weighted toward life sustaining equipment.

Utilities are not normally considered life threatening. In remote bases they are subject to Murphy's law, "Anything that can go wrong will go wrong." Almost every combination of mishap does occur and in orbit the introduction of microgravity produces additional unknowns. In remote bases, a series of rules of thumb generally evolve to minimize the safety risk. These "rules" in severely cold areas included inside warmed utilities, water lines which can't leak toward electrical, no connection between water and gray water systems including one valve, etc. In Alaska, bentonite was used in the drinking water system and resulted in a distinctive taste which cut drinking water consumption to close to zero. In airliners they used to furnish drinking cups, now ask the cabin staff about drinking the water in the plane's water system, and you find it isn't usually recommended. Utilities are technical and life threatening plus deserve a special weighted evaluation factor.

NASA-AMES SPACE STATION STUDY - 1984

The first human factors study with Marc Cohen as technical monitor explored a wide variety of Space Station related concepts. These included concepts for central beams, work pods for the exterior of the station, a flat end cap concept for the modules, and human factors considerations for flexible work space.

The prerequisites for a commercial workspace were expanded and defined. The interfaces and scenarios for various types, sizes and shapes of commercial space participation were explored. From these studies a new series of concepts evolved for the commercial participation at Space Station.

¹ Women seemed better than men in decorating and personalizing their personal space in Alaska. This included wall coverings, personal photographs of family, color, texture, music, hobbies, organizing social functions and attitude.

OUTCOMES OF THE 1984 NASA-AMES STUDY

The study produced key human factors variables for anthropometrics, ergonomics and systems integration.

1. Internal utilities distribution is a major design driver.
2. Workstations have a critical relation to utility distribution. The commercial use of workstations is important on the station and on the surface. The commercial viability of the commercial experiments on the station can be enhanced and stimulated by similar and compatible workstations on the station and the users surface facility which are able to communicate in real time.
3. Together utilities and equipment interact with spatial composition.
4. With the budget available, only the central beam and the engineering workstation were carried forward to the next contract.

APPROACH

The approach is basically "Inquiry by Design."

1. Study of workstation/utilities/human factors requires that test designs postulate an interior configuration free from the one gravity conventions of up - down, floor - ceiling, etc. This does not preclude evolution of conventional forms from research designs.
2. Search for possibilities led to the selection of the central beam approach as most free of architectural conventions. It is to be used as a "Test Bed" for the inquiry by design.
3. Develop theoretical approaches to interior configurations to explain interaction of beams, work pod derivative and spatial structure.
4. Develop interior configurations to test theoretical variables.
 - a. Seven configurations of beams, grouped in three pairs
 - b. Human factors/commercial/functional
 - c. Potential Evaluation Criteria
5. Thrash - wring out human factors issues as oppositions and gradients and as components of human productivity - operations/design/human productivity.
6. Observations - Models are an effective method of isolating and studying interior module problems prior to a full scale mock up.
7. Findings - Several beam variations have merit.
8. Recommendations leading to the proposed Evaluation Criteria.

HUMAN FACTORS/HUMAN PRODUCTIVITY VARIABLES

A variety of evaluation tools have been used in the development of hardware for use in orbit. The development of theoretical approaches to the evaluation criteria for interior configurations to explain and relate the interaction of the beam, work pod, other interior

equipment and spatial composition is needed. It is easy for an engineer to apply engineering design tools to an interior hardware item, but the architectural design tools address not only the equipment within a volume, but the volume itself. The human factors of the volume may in some cases be more important to the human productivity of the occupants than the individual interior hardware components.

The proposed methodology for identifying, selecting and implementing the design criteria is a combination of the following general areas of evaluation:

TECHNICAL

EFFICIENCY

HUMAN ACCEPTANCE

MAINTENANCE

The combination of the above criteria with user defined weighting factors provides a loose standard or universal evaluation of the Space Station hardware and volumes with a human emphasis. The weight of the individual components varies with the type of situation to be evaluated.

The weighted factors for two different kinds of interior architectural items are shown in Figure 1. Figure 1 depicts two ends of the spectrum in allocating the weighted components of the total evaluation factor.

TECHNICAL

The technical portion of the total evaluation factor is expected to be user defined, but to contain criteria such as:

- A. Technical Design
 - 1. Weight
 - 2. Volume
- B. Technical Operation/Performance
- C. Standardization

EFFICIENCY

The efficiency portion of the total evaluation factor is expected to be user defined, but to contain criteria such as:

- A. Volumetric Analysis
 - 1. Packing Density
 - 2. Utility Volume
 - 3. Equipment Volume Capability
- B. Frontal Area
- C. Life Cycle Consideration

This factor is expected to strongly reflect the factors which set the Space Station Program apart from previously, relatively short "visits" to space from a permanently manned facility.

HARDWARE EVALUATION FOR SPACE STATION

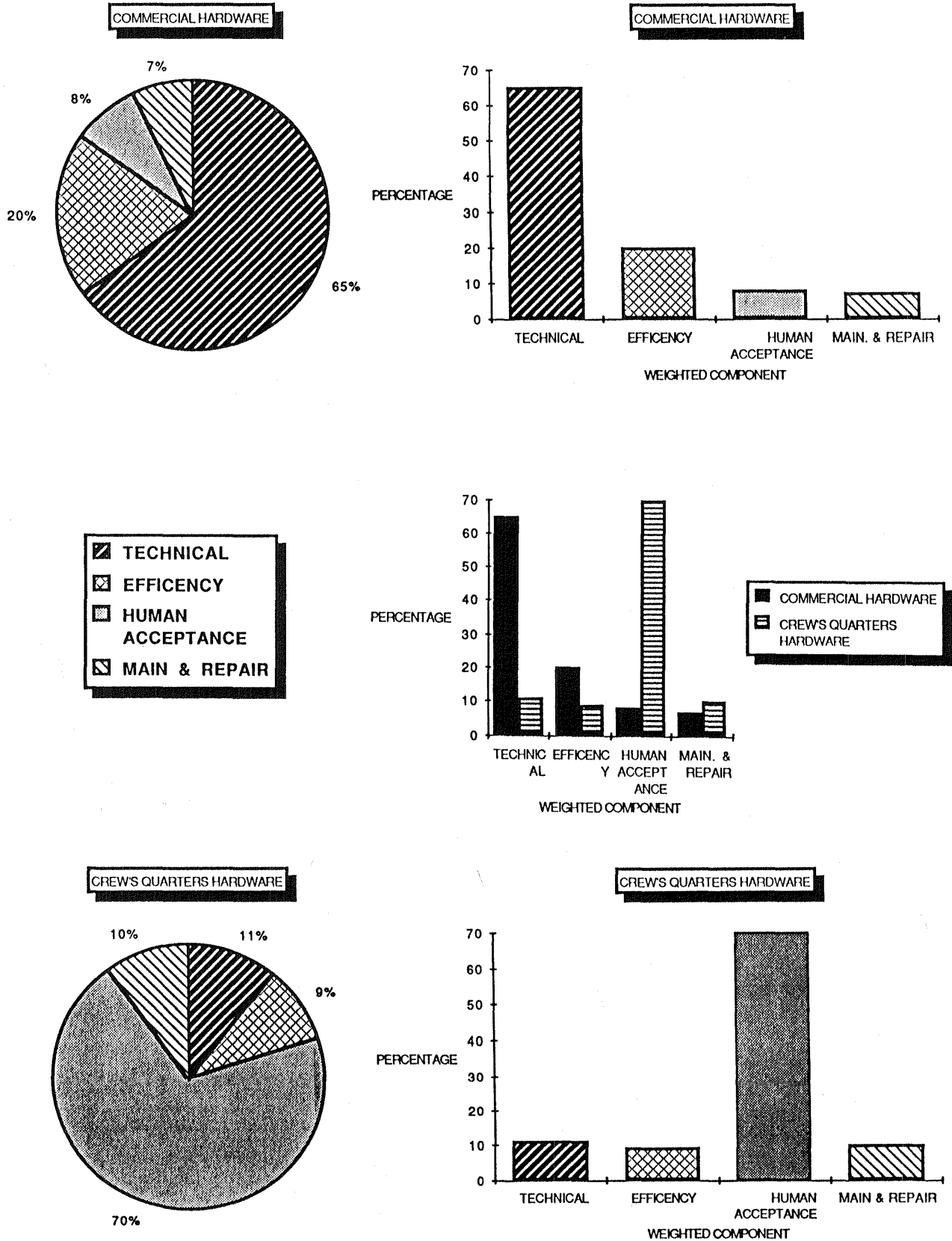

Figure 1 Recommended Evaluation Factor Example

Short term visitors to Alaskan camps were surprised when they returned to spend 90 days and experience the difference in both human and non-human aspects with a full tour of duty.

HUMAN ACCEPTANCE

The human acceptance portion of the total evaluation factor is expected to be user defined, but to contain criteria such as:

- A. Ergonomics
- B. Safety
- C. Crew Time/Efficiency
- D. Training
- E. Human Feel
- F. Crew Traffic
- G. Ease of Use of Repair Manuals in Microgravity

This component of the total evaluation is meant to be almost totally evaluated by the individuals to actually be on orbit.

MAINTENANCE

The maintenance portion of the total evaluation factor is expected to be user defined, but to contain criteria such as:

- A. Logistics and Equipment Changeout
- B. Access to Inner Hull
- C. Repair Sequence
- D. Maintenance Required
- E. Commonality
- F. Surface Transportation
- G. Component Commonality

This may be the most important of the evaluation factors, if surface experience is to be believed as an indicator of orbital problems with human productivity in long duration missions.

The exact weighting and breakdown of the general categories is a matter of opinion and every reader will have a different approach to the utilization of the evaluation tool. The value to the industry may be awkward. Before we can develop a more rigorous evaluation criteria and methodology, we must first test and try to apply this method.

NEUTRAL BODY POSTURE

A variety of anthropometrics are available to the Space Station development program. Microgravity alters the human form. The surface based one gravity Male/Female Anthropometric Envelopes change in microgravity. Brand Griffin's work in 1978 has been abstracted and expanded with the assistance of the computer to depict a realistic, precise depiction of the human body in orbit. The neutral body posture is body position in microgravity in orbit which differs from a normal body posture on the surface in a one gravity situation. The physical differences in the human body can be depicted easier than

the fluid, mental and other changes to the human as a whole. The one gravity neutral body position will never approach a neutral position in orbit since the body is always under the influence of gravity on Earth.

In an attempt to start depicting the human form in a realistic manner in orbital situations, the author has abstracted and placed in the computer several scaled drawings from Brand Griffin's work. See Figure 2 for the top, front and side view from THE INFLUENCE OF ZERO-G AND ACCELERATION ON THE HUMAN FACTORS OF SPACECRAFT DESIGN by Brand Griffin in 1978, NASA-JSC 14581 (Ref. 1). It should be noted the computer enhanced figure on the left is slightly taller than the two on the right. The computer can be used to convert this neutral body position to the scaled human form as shown in Figure 3. The resulting human form is a male approximately 5' - 10". In microgravity this human form is reduced or slumped into a neutral body position approximately .95 less in height in orbit.

ENGINEERING WORK STATION

The Engineering Workstation is an expansion of the worksphere and work pod idea developed in NASA CR 3941. The Worksphere is shown in Figure 4. It was designed to give the user a controlled environment capable of user defined lighting, air circulation, human interruptions and selected human productivity equipment. This size of workstation makes it suitable for attachment to the crew quarters of each person on orbit and can act as an orbital desk. Several types of workstations will be required for the Space Station. The scope of the workstations is expected to range from a personal workstation as described above with individual human productivity tools and potentially personal volume, communications and entertainment considerations to complex control modules capable of operating the station.

The Engineering Workstation is an expansion of the worksphere, a four foot diameter sphere that expands to a larger volume. The work pod is an eight foot in diameter externally attached volume. The internal controlled work volume for Space Station is limited by the hatch diameter and the logistics changeout procedure. The external controlled volume is expected to evolve to a variety of externally attached module volumes already starting to appear in the commercial sector. (An orbiter compatible SPACEHAB Module capable of evolving into an attached volume to the Space Station has been announced by an entrepreneurial firm in Oct 85 at the IAF Congress in Stockholm, Sweden). The size of the externally attached pressurized volume is limited by the transportation system initially and ultimately will be limited by the assembly of components at the station.

Several types of workstations will be required for the Space Station. The scope of these workstations will include a personal workstation with individual human productivity tools, the orbital desk and potentially personal volume, communications and entertainment considerations. The module control station will be capable of simultaneous use by two crewmembers and capable of controlling the module and station from each module location. Four or more control stations are required if each module requires an individual control station. All workstations are assumed to be capable of changeout through the normal logistics and 50 inch hatch system. Figure 5 depicts a small workstation with a single occupant. The volume will afford the user complete control over lighting, air circulation, equipment definition and security. The full up workstation capable of controlling the station and storing/retrieving all technical and maintenance data might take three submodules capable of being combined into a concept shown in Figure 6. The same concept combined with one of the central beam configurations to be discussed later is shown in Figure 7. Figure 8 is a plan view of the same concept.

VERTICAL HEIGHT CHANGE

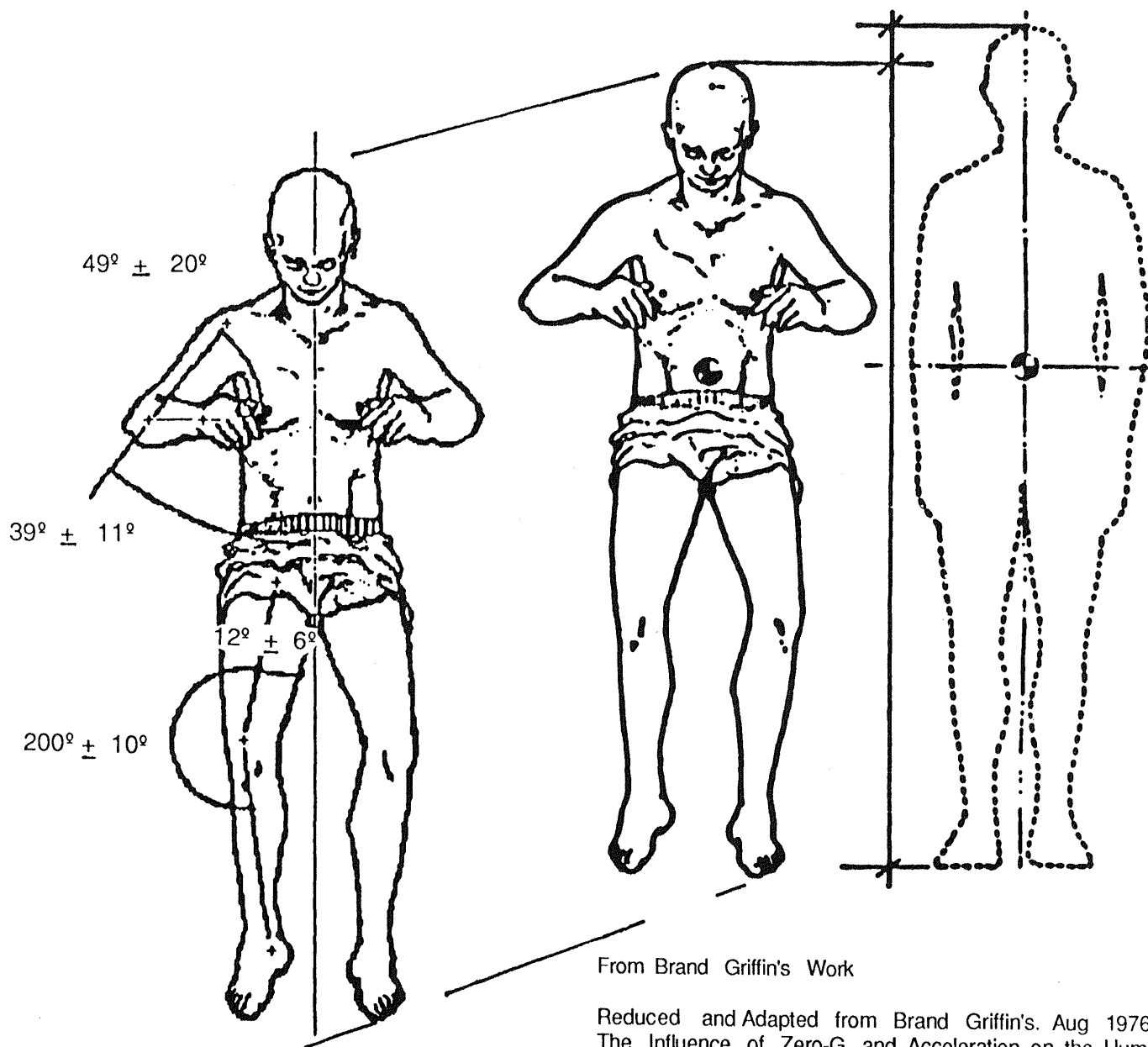

FRONT VIEW

From Brand Griffin's Work

Reduced and Adapted from Brand Griffin's. Aug 1976
The Influence of Zero-G and Acceleration on the Human
Factors Of Spacecraft Design, JSC 14581

NEUTRAL BODY POSITION

COMPUTER MODEL

Figure 2 Brand Griffin's Neutral Body Position

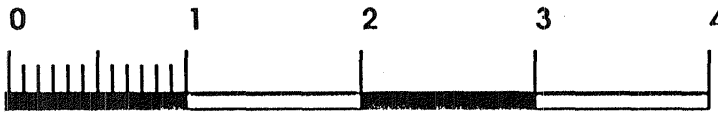

SCALE **1" = 1' - 0"**

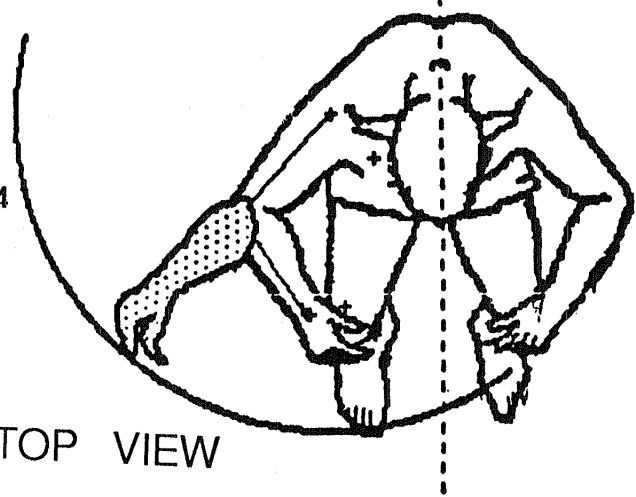

TOP VIEW

ADAPTED FROM BRAND GRIFFIN

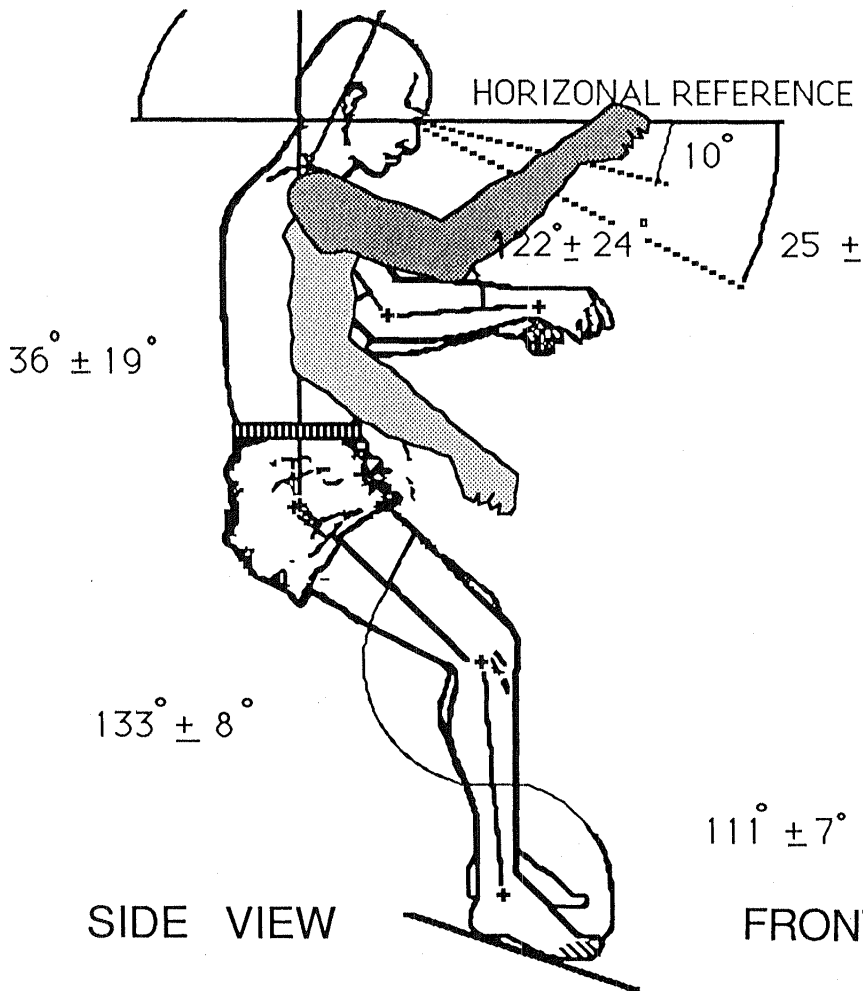

SIDE VIEW

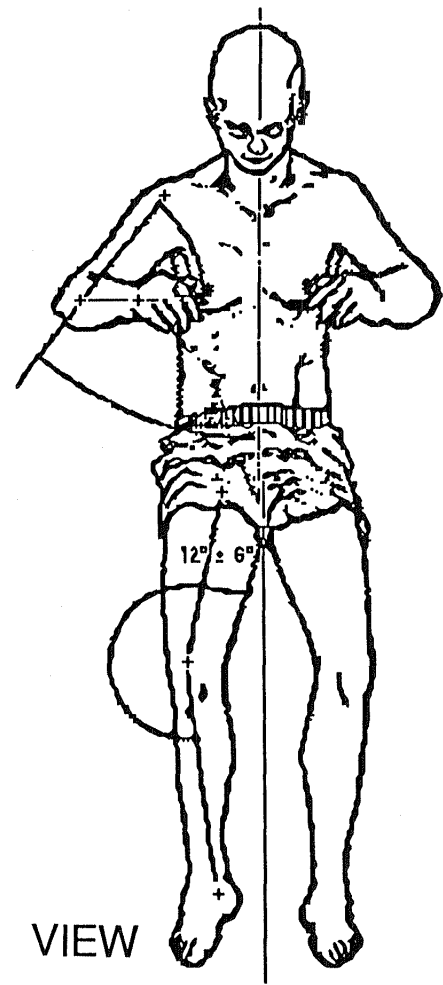

FRONT VIEW

Figure 3 Neutral Body Position Computer Model

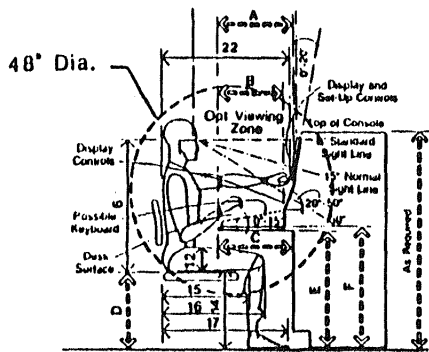
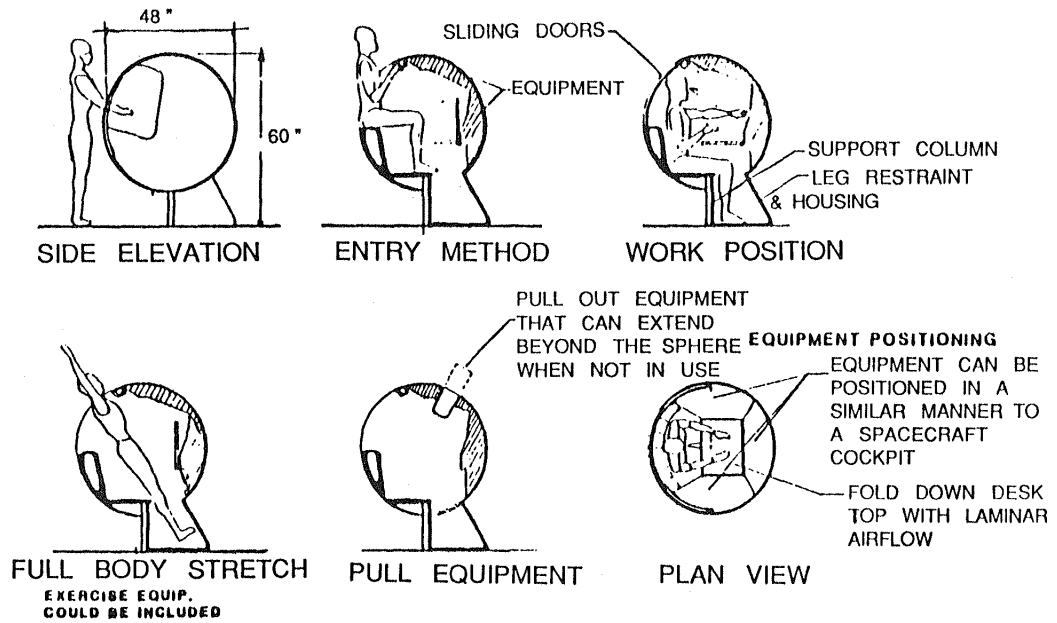

**DESIGN GUIDELINES/
WORKSTATION DISPLAY CONSOLE**

FROM HUMAN FACTORS ENGINEERING
U. S. AIR FORCE SYSTEMS COMMAND HANDBOOK DH 1-3

	in	cm
A	16-18	40.6-45.7
B	16 min	40.6 min
C	18 min	45.7 min
D	15-18 adjust	38.1-45.7
E	26.5 min	67.3 min
F	30	76.2



WORK SPHERE ARRANGEMENTS

V = ENTRY

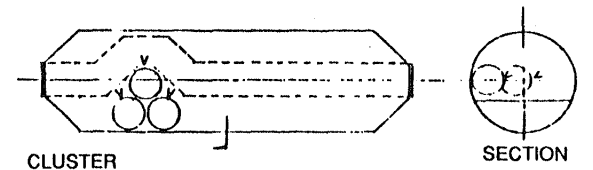
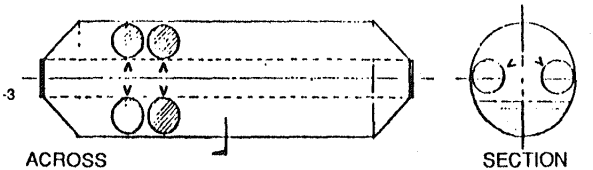
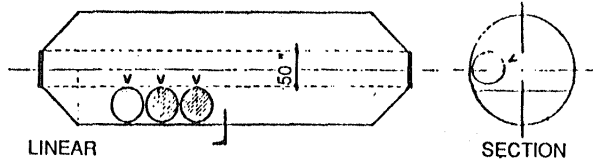
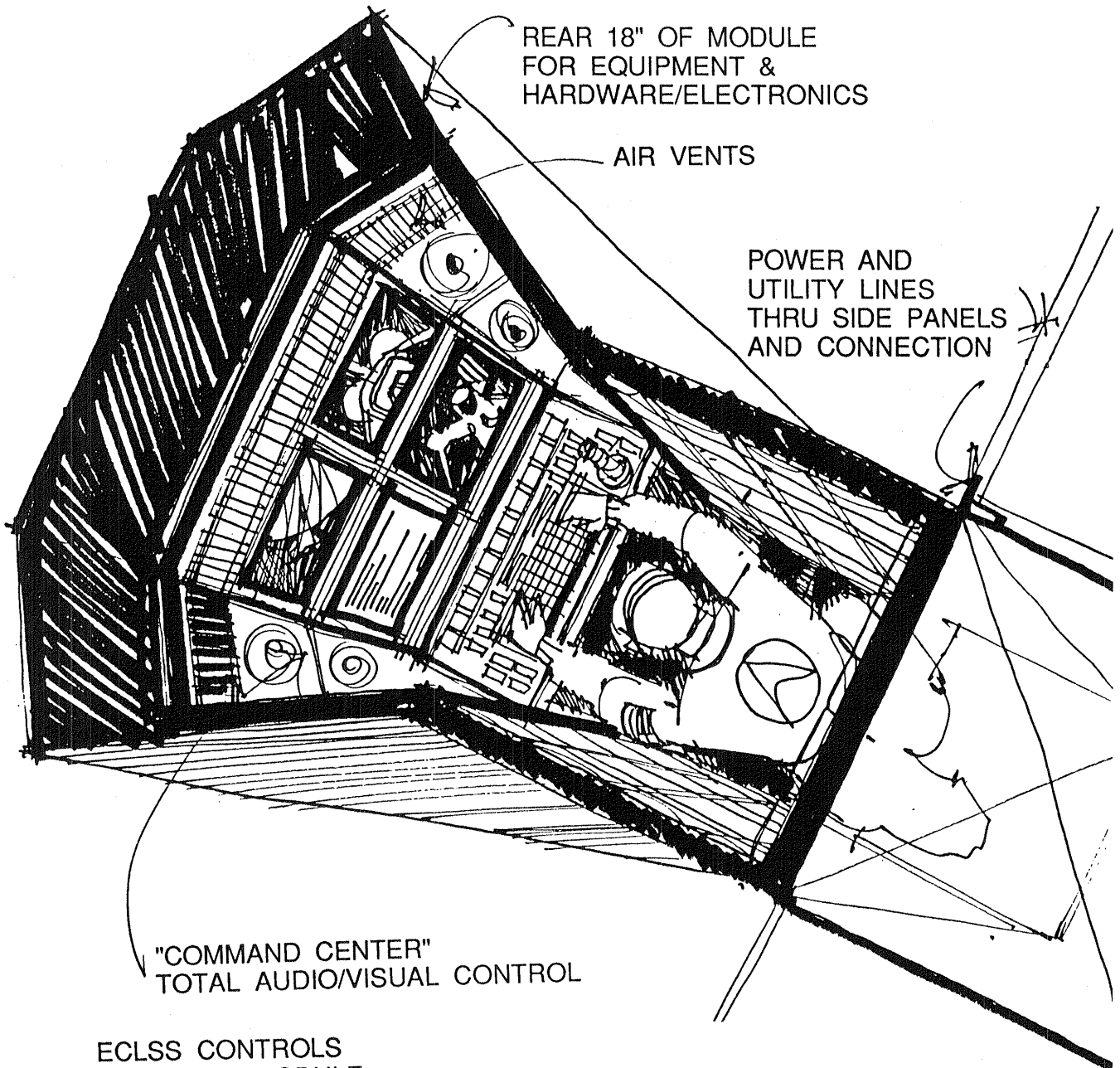

Figure 4 Workspace from NASA CR-3941



REAR 18" OF MODULE
FOR EQUIPMENT &
HARDWARE/ELECTRONICS

AIR VENTS

POWER AND
UTILITY LINES
THRU SIDE PANELS
AND CONNECTION

"COMMAND CENTER"
TOTAL AUDIO/VISUAL CONTROL

ECLSS CONTROLS
FOR EACH MODULE

ENTRY HATCHES CAN BE
CLOSED FOR TOTAL PRIVACY
BY SLIDING PANELS

Figure 5 Workstation Rendering

MODULES ATTACH
TO CENTRAL
"H" BEAM

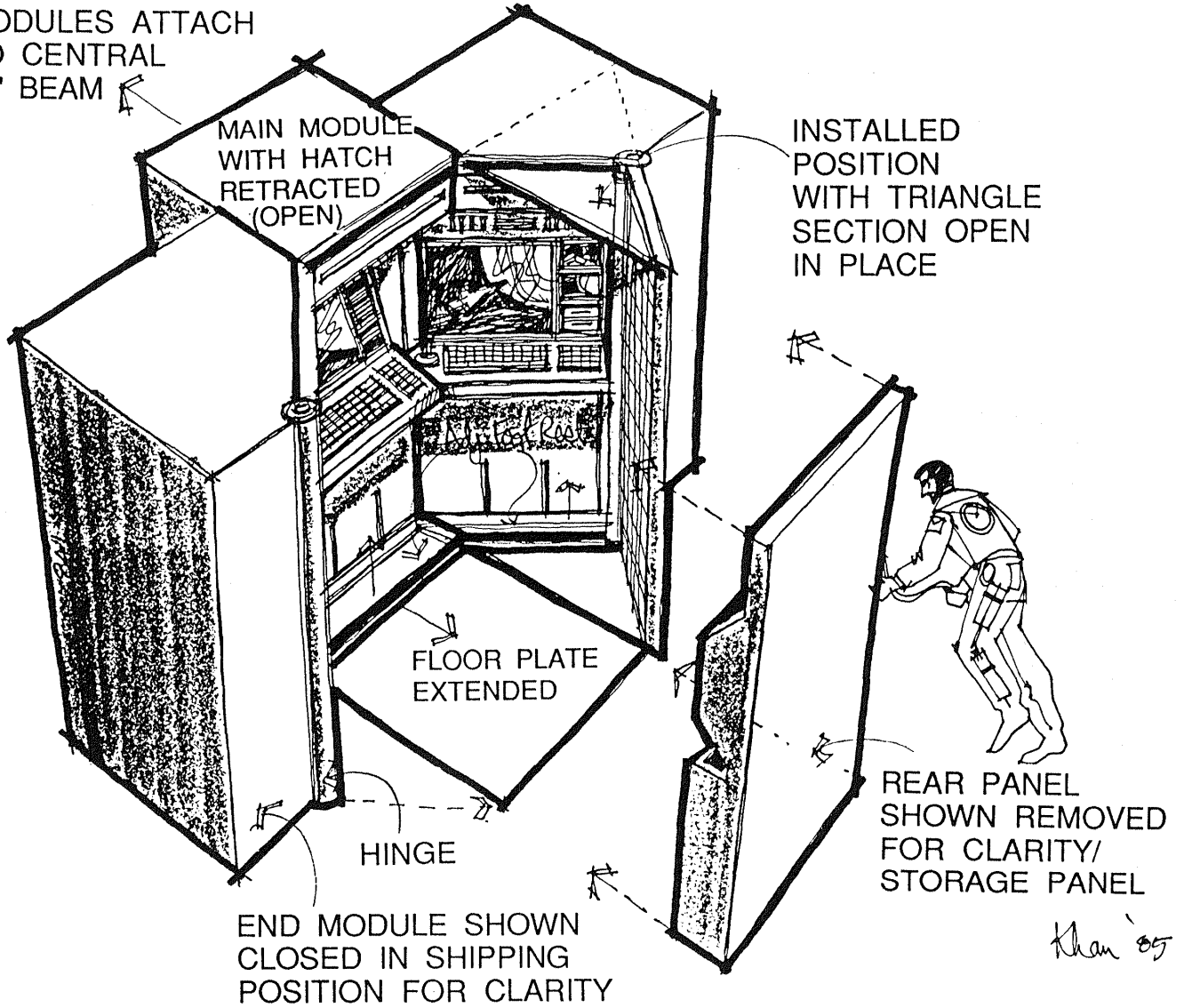

WORK STATION
CONSTRUCTED FROM
3 SUBMODULES - 3' X 3' X 7'
SHOWN IN EXPLODED VIEW
FOR CLARITY

Figure 6 Large Workstation

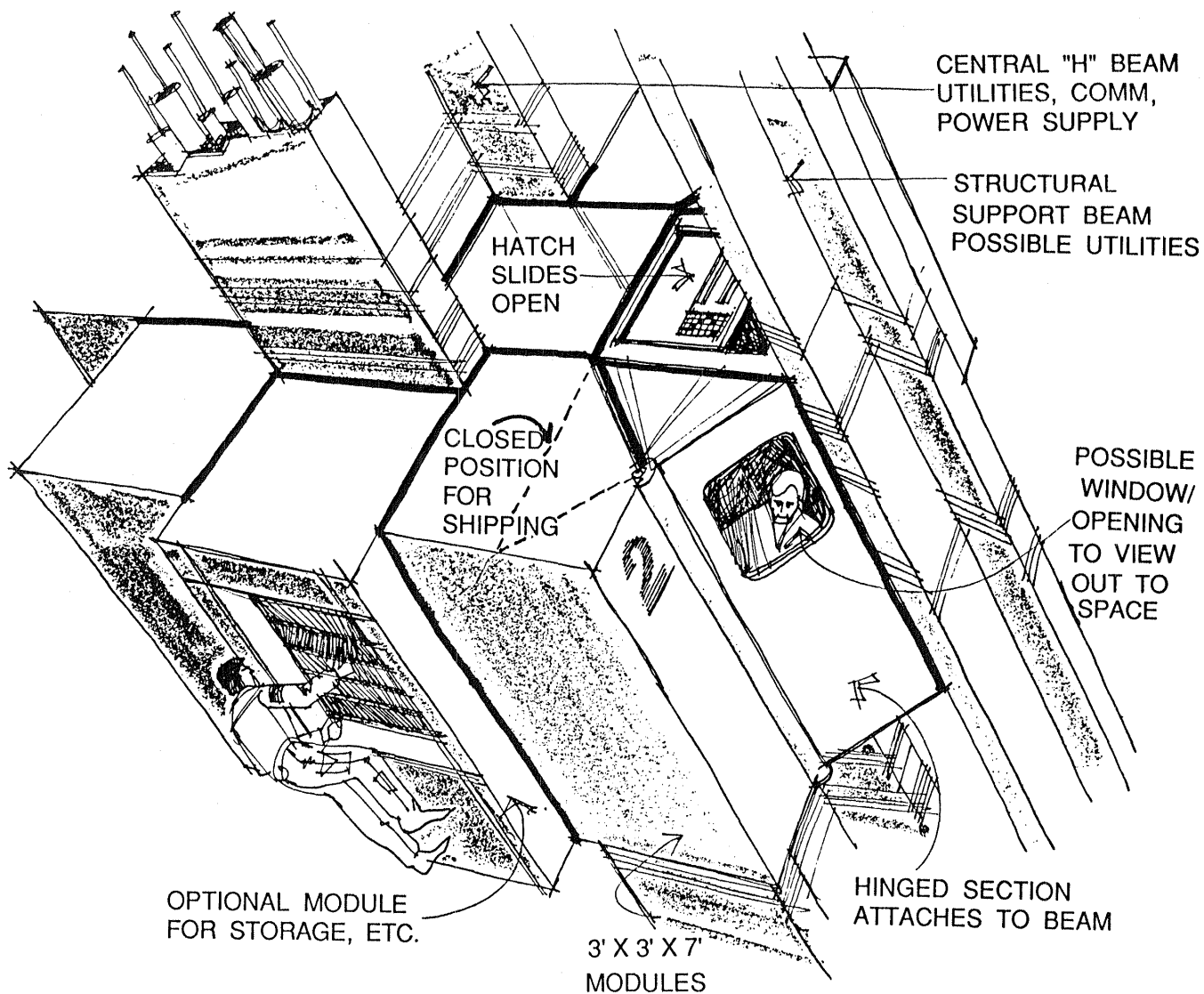

LARGE WORK STATION
CONCEPT FROM 3 MODULES
3' X 3' X 7'

Khan 35

Figure 7 Space Station Application

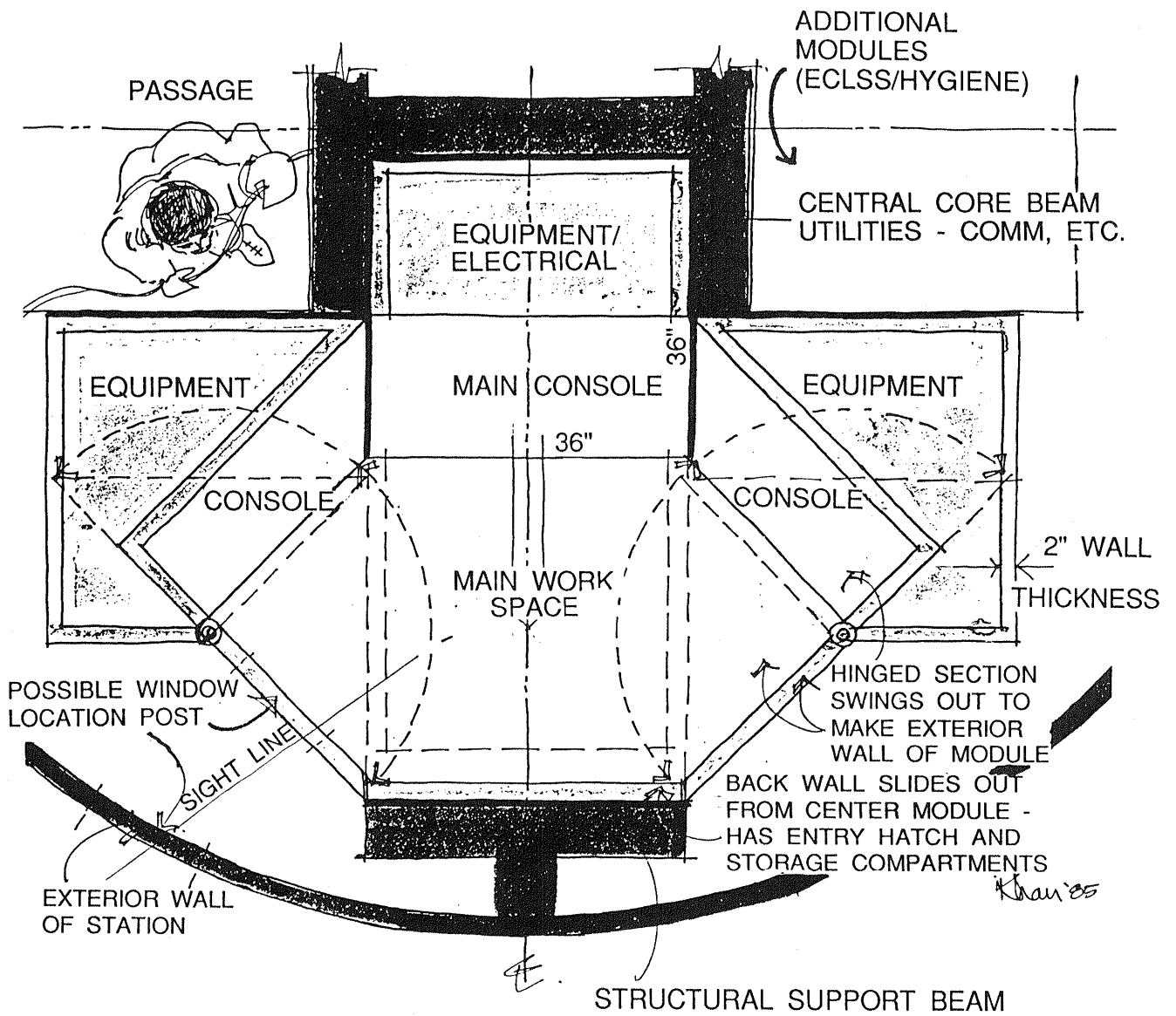

TYPICAL WORK STATION
 CONCEPT - MODULAR
 SYSTEM FROM
 3 MODULES - (3' X 3' X 7')

Figure 8 Top View Large Workstation

The commercial aspects of the Engineering Workstation are significant. On Earth, "Workstations" are proliferating in the emerging personal computer market. (Newsweek, Feb. 3, 1986, p. 61, describes the "workstation" as powerful personal computers - for scientists, engineers and other high-tech professionals). If personal computers evolve in the next eight years as much as the last eight, then each station occupant will have an individual workstation on the surface and in orbit. It will be like a typewriter is today and a sliderule was 20 years ago. It will be the tool of the day and use telecommunications to tie remote work places together. The human factors surrounding the work station is an area of research with both Space Station and surface computer industry implications.

NEUTRAL BODY POSITION REFINED

In order to layout the equipment for an Engineering Workstation, additional refinement of the neutral body position in orbit is required. The neutral body positions depicted earlier are refined by graphically rotating each human joint through the range of arm and leg positions. Figure 9 shows the top view body arm rotations. Figures 10 and 11 depict the front views as the arm and leg joints are rotated. Figures 12 and 13 show the same rotations from the side view.

CREW WORKSTATION

The computer oriented Engineering Workstation Tools on the surface have changed since the Skylab time period from an expensive main frame computer accessory at hundreds of thousands of dollars to a small unit (\$5k) and within personal computer capability. The personal computer has become a commercial consumer item and is likely to reach the 500 megabyte capacity in the near future. Each crewmember is likely to own a business computer on Earth to complete work and will expect a similar situation in orbit. It is not unrealistic to expect the Engineering Workstation to use modified off the shelf business/science computer hardware and take advantage of the cost and technology updating available. This also permits the workstation to be user defined to fit the occupant's requirements and permits the workstation to update its computer technology after it is available in the marketplace. The goal and definitions of a personal Engineering Workstation are shown in Figure 14. The approximate equipment requirements for a personal Engineering Workstation are shown in Figure 15.

The approximate Engineering Workstation components are shown in Figure 15 based on some technology advancements in the 6 to 8 years until Space Station deployment. It depicts the perceived simple general personal needs of a crewmember in orbit. The strawman crewmember is a payload specialist working for a commercial organization with a team of individuals on Earth assisting the on-orbit individual to perform research and development work on a variety of different equipment in one or more lab modules. The individual spends one hour a day communicating verbally with the surface directly from the commercial lab module to the commercial organization on Earth. The communications include verbal and technical data links from various experiments and research. The crewmember has a technical data gathering device which includes an audio capability. The individual uses the data gathering device like a clipboard and uses the Engineering Workstation to store, organize, assemble and communicate the data and perceptions of the day to the group on the ground. Flat screen technology and large storage devices with growth capability are prerequisites for this approach. Each such crewmember brings to the station some plug-in research specific hardware plus user defined software, stored data and entertainment material compatible with the personal "Orbital Desk" system.

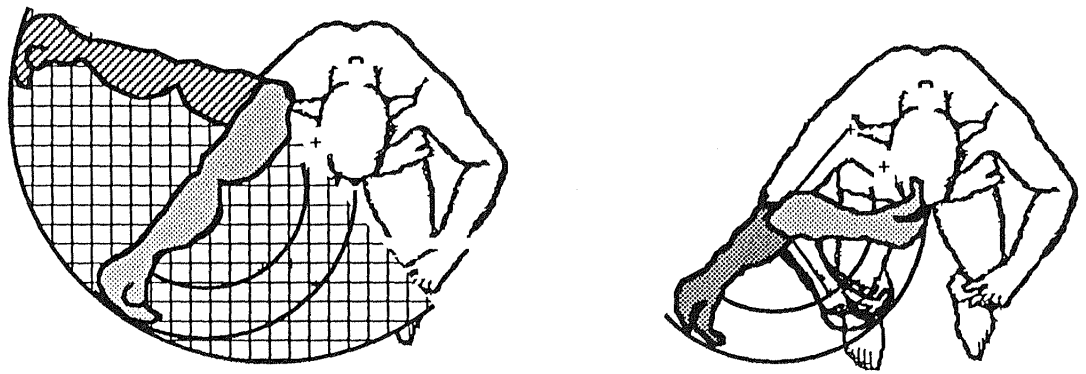

Adapted from Brand Griffin's, Aug 1978 Report
The Influence of Zero-G and Acceleration on the
Human Factors of Spacecraft Design, JSC 14581

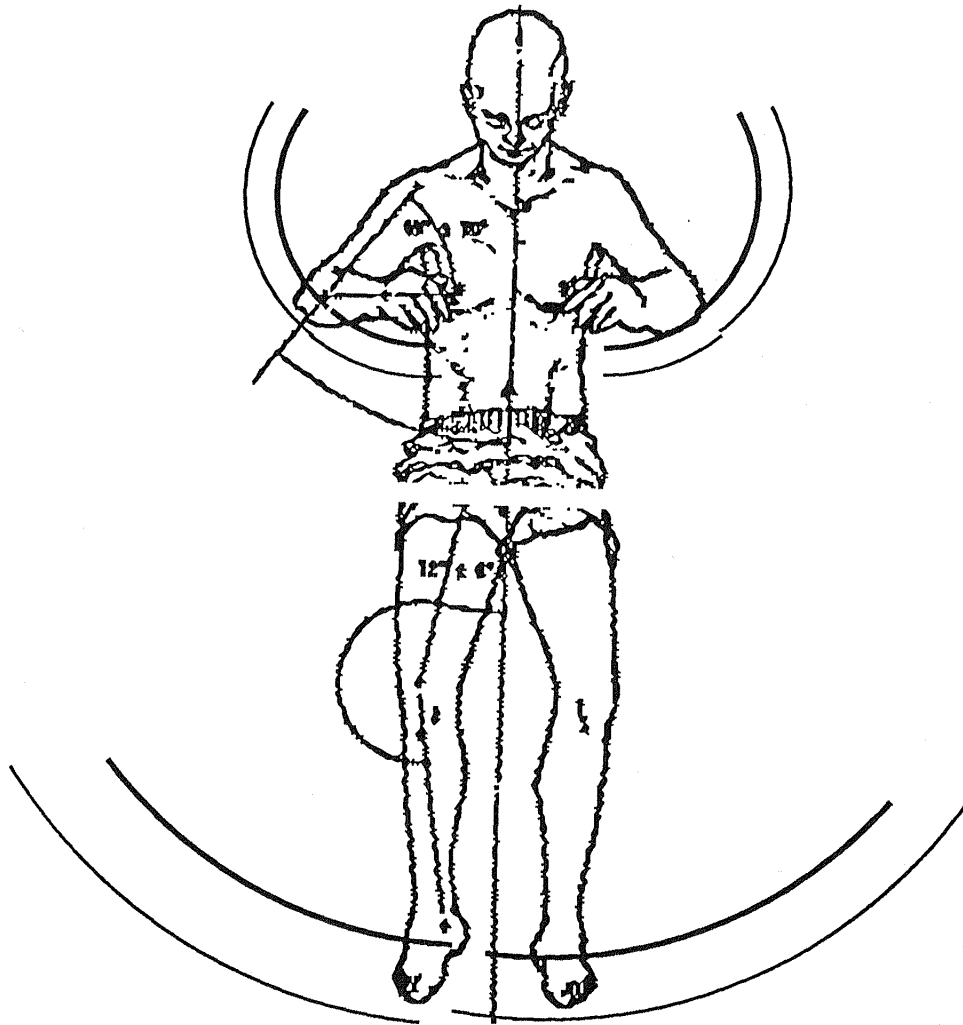
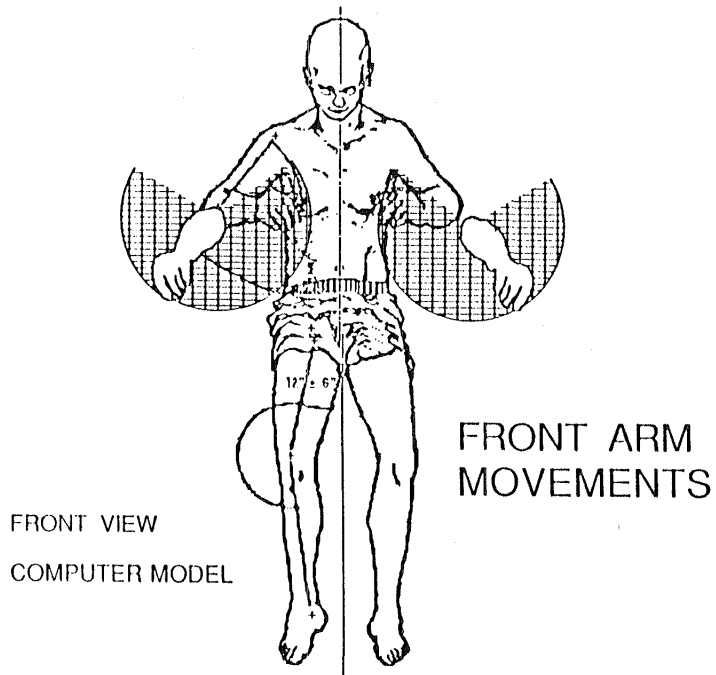

Figure 9 Application of the Neutral Body Position Computer Model



REDUCED AND ADAPTED FROM BRAND GRIFFIN'S WORK TO PRODUCE A
COMPUTER MODEL FOR CONCEPTUAL DRAWINGS AND MODELS.

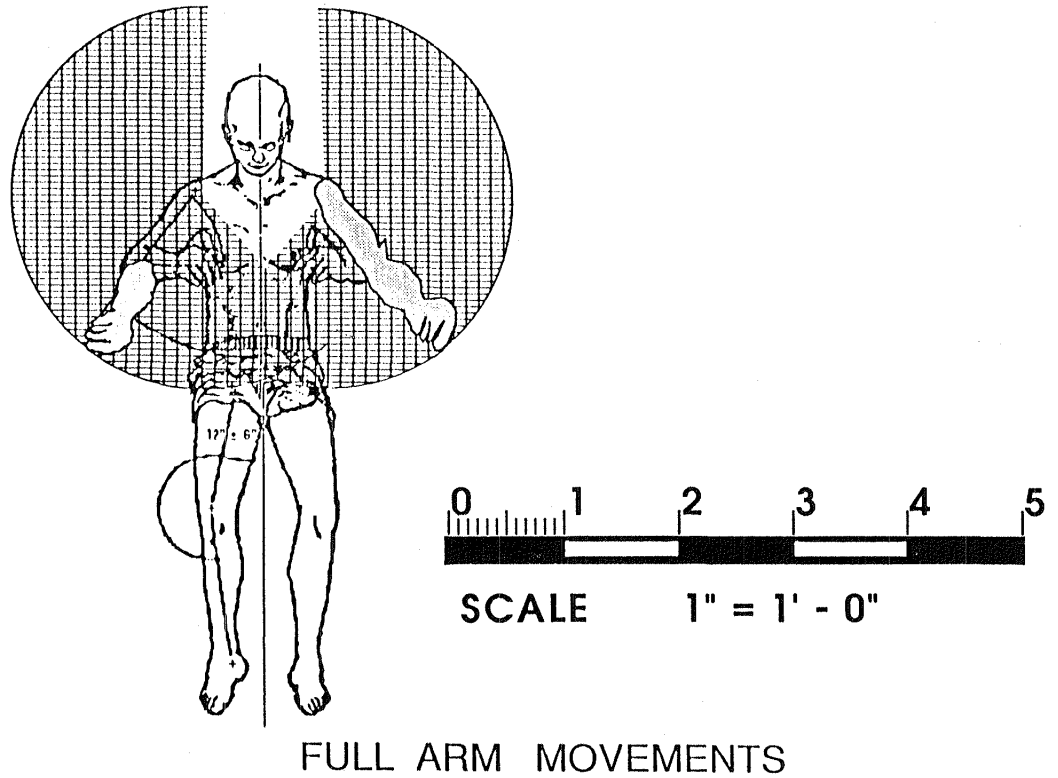
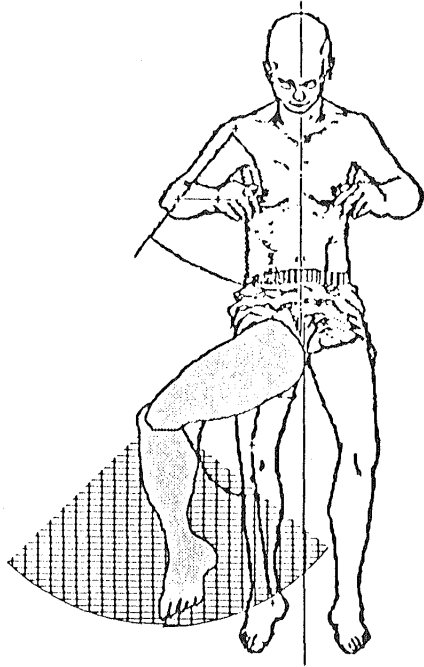
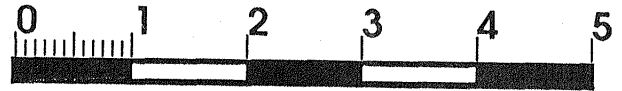

Figure 10 Computer Front View with Arms Rotated



LOWER LEG
MOVEMENTS

REDUCED AND ADAPTED FROM BRAND GRIFFIN'S WORK TO PRODUCE A
COMPUTER MODEL FOR CONCEPTUAL DRAWINGS AND MODELS.



SCALE 1" = 1' - 0"

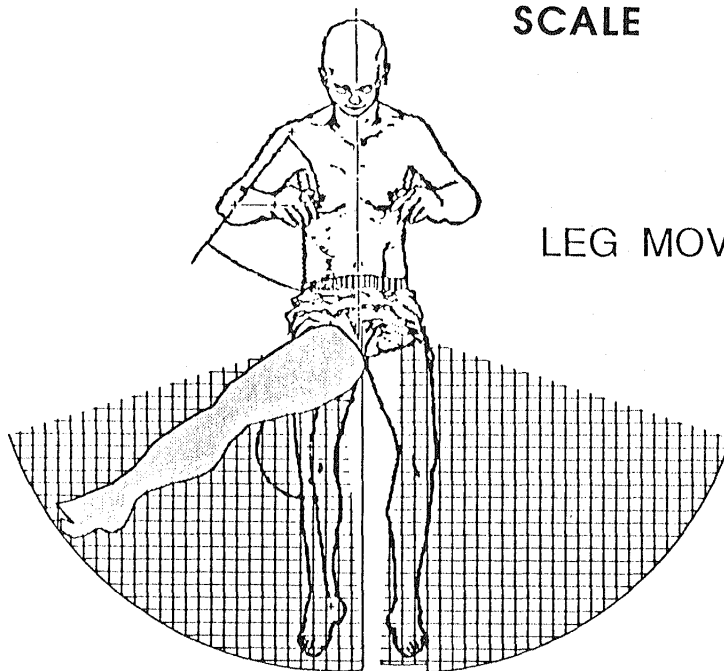

LEG MOVEMENTS

Figure 11 Computer Front View with Legs Rotated

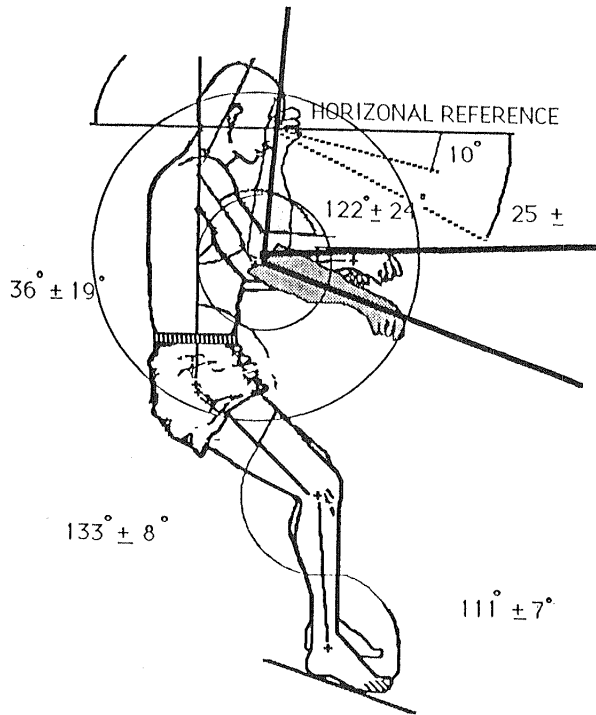

SIDE VIEW COMPUTER MODEL

REDUCED AND ADAPTED FROM BRAND GRIFFIN'S WORK TO PRODUCE A COMPUTER MODEL FOR CONCEPTUAL DRAWINGS AND MODELS.

LOWER ARM MOVEMENTS

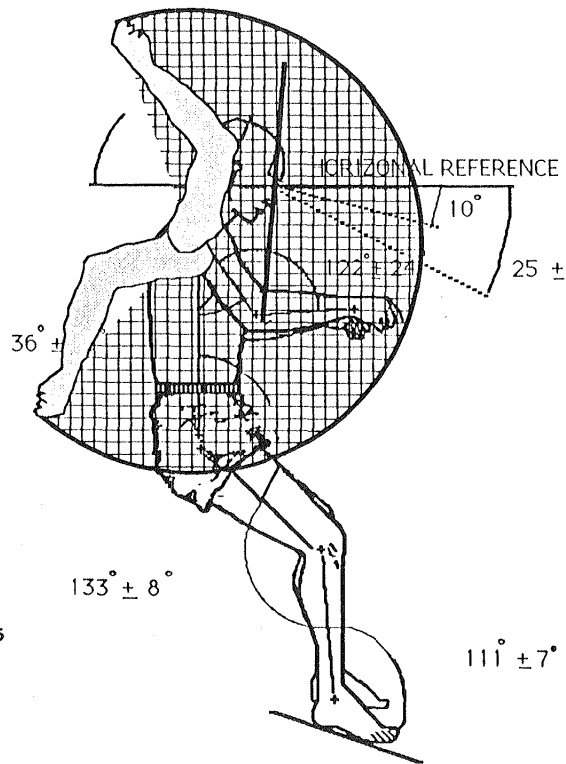

SCALE 1" = 1' - 0"

SIDE UPPER ARM MOVEMENTS

Figure 12 Computer Side View with Arms Rotated

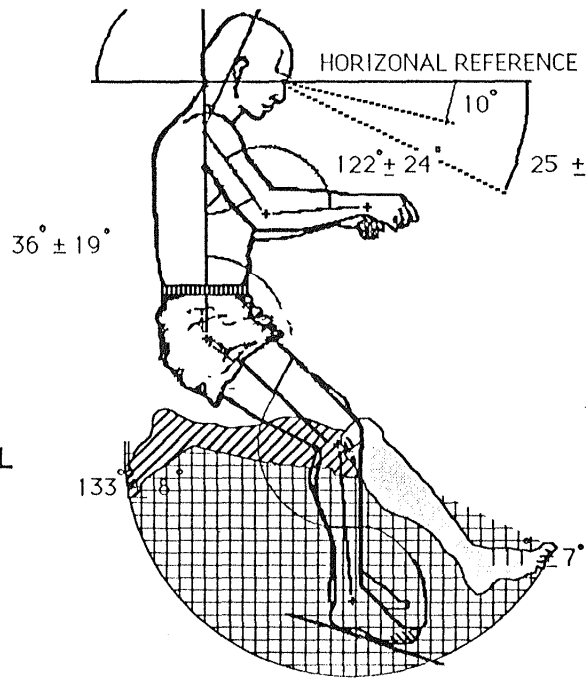

SIDE VIEW COMPUTER MODEL

REDUCED AND ADPATED FROM BRAND GRIFFIN'S WORK TO PRODUCE A COMPUTER MODEL FOR CONCEPTUAL DRAWINGS AND MODELS.

LOWER LEG MOVEMENT



SCALE 1" = 1' - 0"

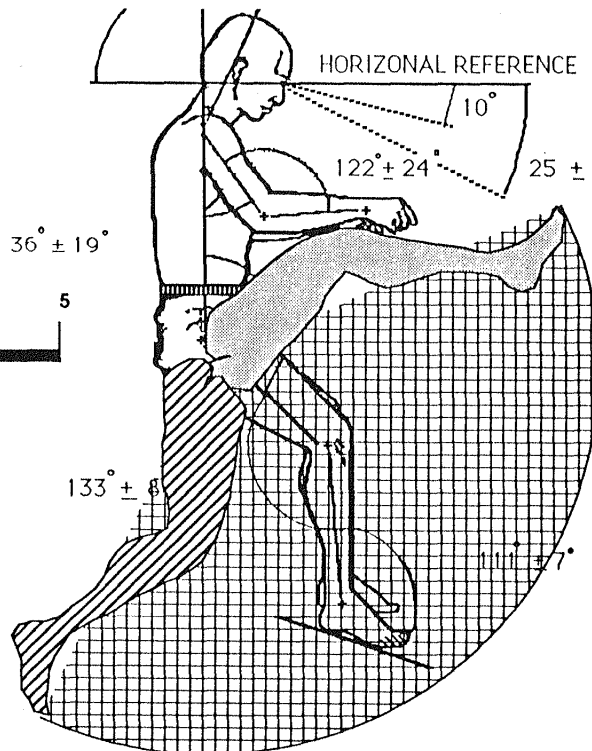

UPPER LEG MOVEMENT

Figure 13 Computer Side View with Legs Rotated

ROUNDED CORNER TYPE SUB MODULE

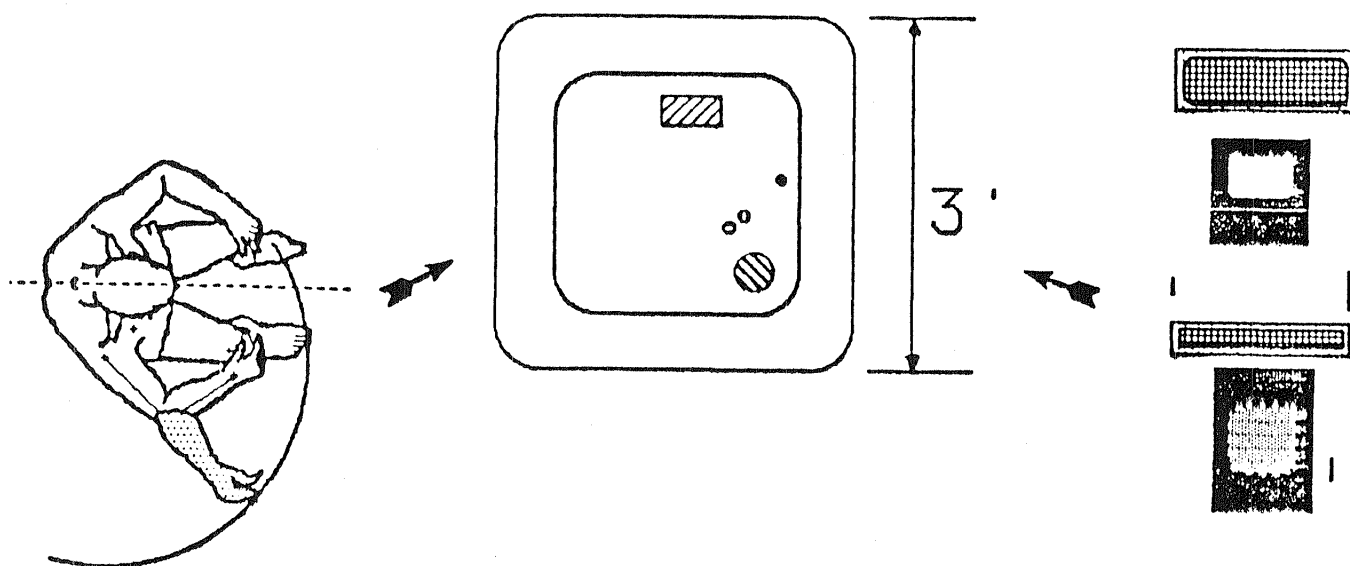

ENGINEERING WORKSTATION

GOAL:

CREATE AN ENGINEERING WORKSTATION IN OR NEAR EACH PERSON'S CREW QUARTER FOR COMMUNICATIONS, DATA REDUCTION, REPORT ASSEMBLY, VIDEO ENTERTAINMENT, SECURE WORK, INFORMATION STORAGE AND PERSONAL VOLUME.

DEFINITION

A USER DEFINED HUMAN PRODUCTIVITY VOLUME WITH DEVICES AND SOFTWARE TO ASSIST THE INDIVIDUAL OCCUPANT. THE VOLUME PERMITS CONTROLLED AIR CIRCULATION, LIGHTING, INTERIOR, COLOR AND TEXTURE, PERSONAL RESTRAINT, PERSONALIZED ENHANCEMENTS AND IS LOCKABLE FOR SECURITY REASONS. THE USER DEFINES THE EQUIPMENT TO BE INSTALLED INTO THE STANDARD ATTACHMENT FITTINGS AND STANDARD INTERFACES. THE WORKSTATION INTERFACES WITH THE VIDEO CAMERA FEEDS AND PROVIDES THE USER WITH ACCESS TO ALL CAMERA VIEWS AND CONTROL OF REMOTELY CONTROLLED CAMERAS TO PROVIDE A SUPERIOR NEAR WINDOW QUALITY PICTURE OF INTERIOR AND EXTERIOR VIEWS INCLUDING EARTH.

Figure 14 Engineering Workstation Goal & Definition

ENGINEERING WORKSTATION

EARLY ESTIMATE OF THE USER DEFINED EQUIPMENT ANTICIPATED IN A SPACE BASED PERSONAL ORIENTED WORKSTATION CAPABLE OF ENGINEERING ACTIVITIES





ITEM	DESCRIPTION	SIZE
	18" KEYBOARD MODIFIED FOR MICROGRAVITY	2" X 6" X 18"
	FLAT SCREEN CAPABLE OF 8 1/2" BY 11" OR LARGER DISPLAY WITH AIDS AND ACCESSORIES CAPABLE OF VIDEO DISPLAY OF LARGE VARIETY OF SIGNALS INCLUDING MAGNETIC STORAGE, OPTICAL ERASABLE DISCS, EXTERIOR AND INTERIOR VIDEO CAMERAS, EXPERIMENTS AND PROCESS RESEARCH EQUIPMENT	12" X 18" X 4"
	DATA STORAGE WITH THREE OR FOUR DIFFERENT METHODS OF RECOVERY AND STORAGE OF DATA	4" X 5" X 7"
	OPTICAL RECORDING AND ERASABLE STORAGE CAPABLE OF RECORDING, STORAGE AND REMOVABLE OF VIDEO FEEDS, GROUND FEEDS, MAINTENANCE MANUALS, REPAIR DIAGRAMS, HUMAN PRODUCTIVITY TOOLS AND USER DEFINED EXPERIMENT RELATED SOFTWARE. MUST BE CAPABLE OF USER CONTROLLED SECURITY SYSTEM FOR PERSONAL AND PROPRIETARY INFORMATION. SIZED TO STORE IN A MIDDECK LOCKER AND PLUG IN REPLACABLE ON ORBIT.	9.95" X 17.312" X 20.32"
	SAME AS ABOVE EXCEPT NON-STANDARD USER DEFINABLE	9.95" X 17.312" X 20.32"
	EXPERIMENT DEFINED RESEARCH USER CHANGED ON ORBIT	9.95" X 17.312" X 20.32"
	AUDIO/DATA TRANSFER AND RECORDING EQUIPMENT WITH STORAGE AND EDITING CAPABILITIES.	9.95" X 17.312" X 20.32"
	4 EA USER CONTROLLED VIDEO DISPLAY SCREENS CAPABLE OF DISPLAY OF INFORMATION FROM ALL STORAGE DEVICES AND LIVE VIDEO FEEDS FROM INTERIOR AND EXTERIOR CAMERAS	16" X 4" X 18"
	HEAD SET WITH MICROPHONE AND AUDIO/DATA RECORDING DEVICE WORN ON THE LEG THROUGHOUT THE DAY AND CAPABLE OF PLUG IN DATA AND VOICE TRANSFER TO THE EQUIPMENT IN THE WORKSTATION.	10" X 14" X 1"
	2 EA WORK SURFACES CAPABLE OF HAND WRITTEN NOTES AND OTHER "OLD STYLE" COMMUNICATION TECHNIQUES AND GENERAL WORK	10" X 14" X 1"

Figure 15 Engineering Workstation Components

The personal Engineering Workstation is designed to fit within a 3' x 3' x 7' submodule as shown in Figure 16. The exterior envelope is a shipping enclosure to be defined after the inside is determined and is limited only by the 50 inch circular hatch. The unit shown is designed to pass through a 50 inch diameter hatch and fold out to expand its inside dimensions within the station module on orbit. It is passed through the existing logistics system if return to Earth repair is required, but is subsystem changeable and reconfigurable on orbit. The unit is deployable on orbit and uses standard interfaces to the central beam and on the interior between components. The work screen is based on flat screen technology and its position reflects the additional tilt angle anticipated in the human body in microgravity. The enclosure or partial Figure 17 places the work screen and the keyboard. The research in full scale mock-ups will assist in fabricating an orbital testbed on the concept. No body restraint is shown and likely to be the subject of research. One or more types of personal restraints are anticipated, but may be personal choice rather than a single solution.

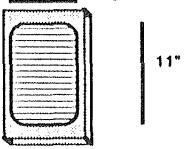
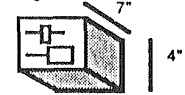
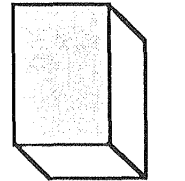
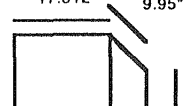
After the placement of other scientific and commercial user defined equipment in the prime work areas shown in Figure 18, the interior evolves as the user requirements are known and understood. Figure 19 depicts the placement of Middeck locker sized, user defined, computer related human output enhancement equipment capable of assisting the user in his or her work.

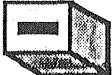
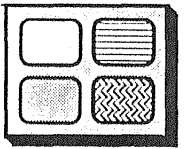
Continued placement of equipment is shown in Figure 20. The equipment can tie into the video, experiment monitoring and control systems on board and assist in the research monitoring on orbit.

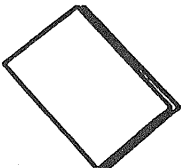
Two types of control stations are emerging from the research. One is a private space used as an "Orbital Desk Plus" with private space, personal communications, proprietary work and a lockable volume. The other is focused on module and station control including module automation control override functions, control of approaching vehicles, EVA activities, material control, Earth communications, data flow control and growth.

PERSONAL WORK VOLUME

The Personal Work Volume is less complicated from an equipment point of view than the module control workstation. It is more subtle and intricate from a human factors point of view. The requirements of the Personal Work Volume are below:

1. Ergonomically correct for the individual, in other words, extreme adaptability to various size and personal preferences of the users.
2. Complete user control and definition of as many of the components of the environment surrounding the equipment including air flow, temperature, lighting, sound, equipment location and touch, smells, texture and color on the interior, charged particles in the air and other comfort features.
3. Provisions for a diversion or break from the normal work load, in space this can be several video feeds from the exterior of the station, which are user selected from all the video cameras on station.
4. Special provisions for comfort and personalization of the volume to include video cassettes of family and favorite Earth scenic views with other stimuli reinforcement.
5. Ten minute changeout for all components.

COMPRESSED ENGINEERING WORKSTATION

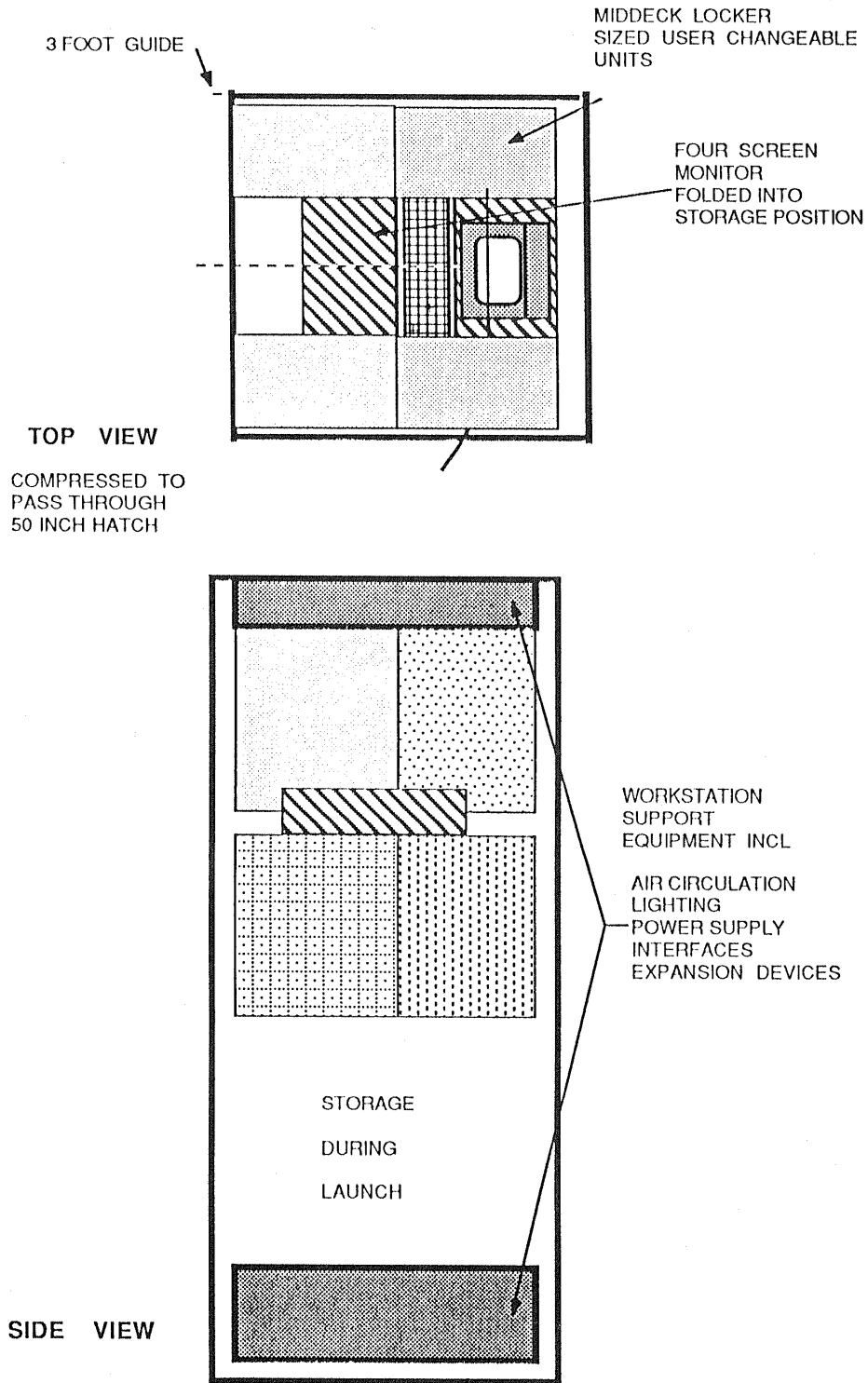

Figure 16 Compressed Transport Unit

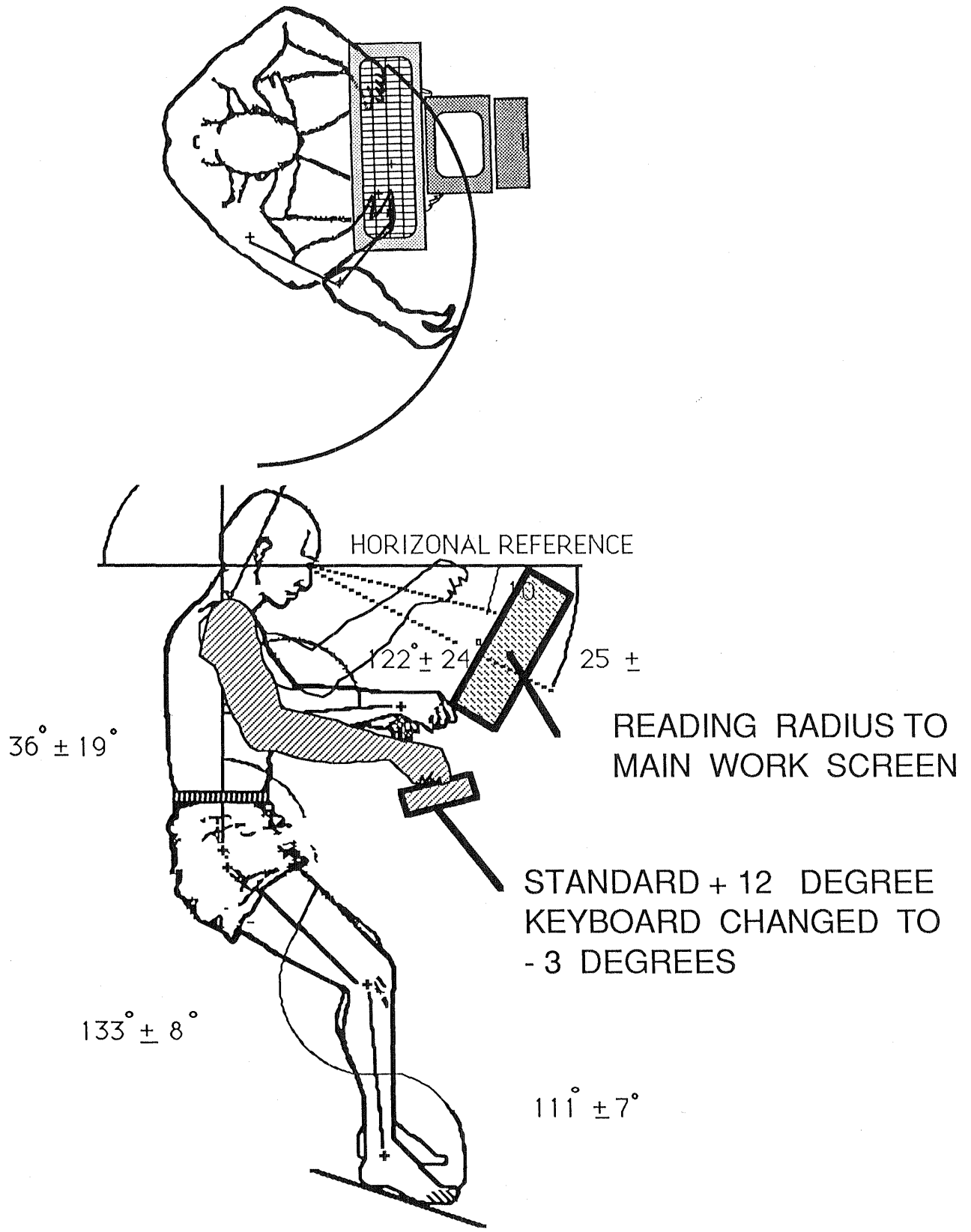

Figure 17 Engineering Workstation Ergonomics

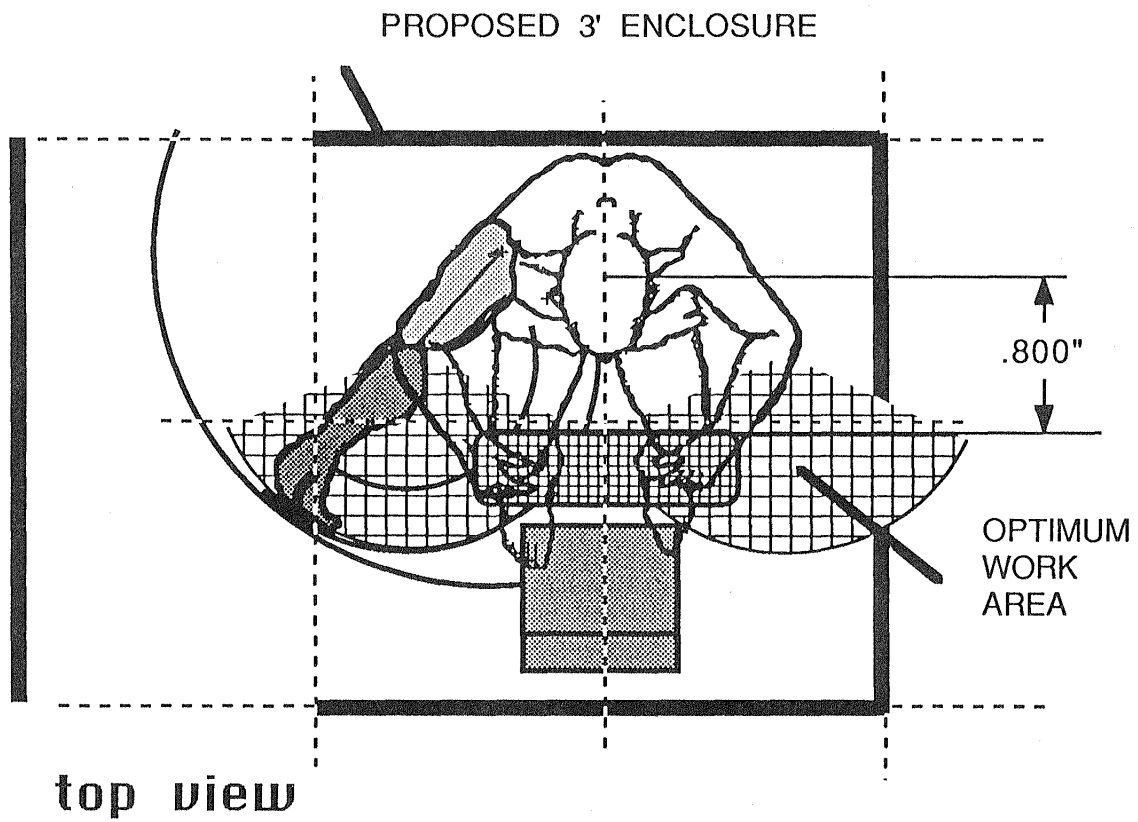
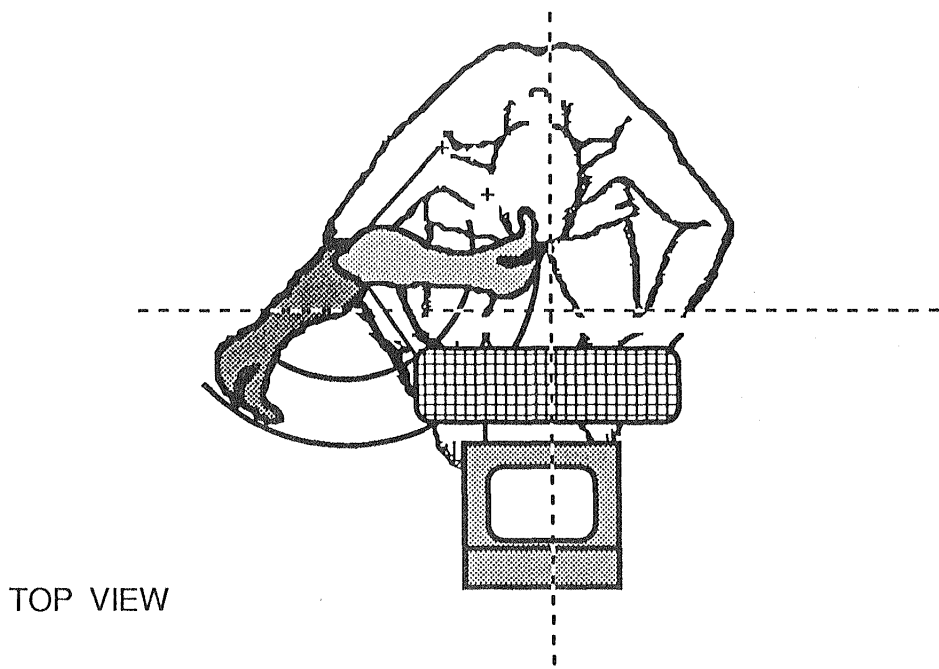

Figure 18 Prime Work Area Workstation

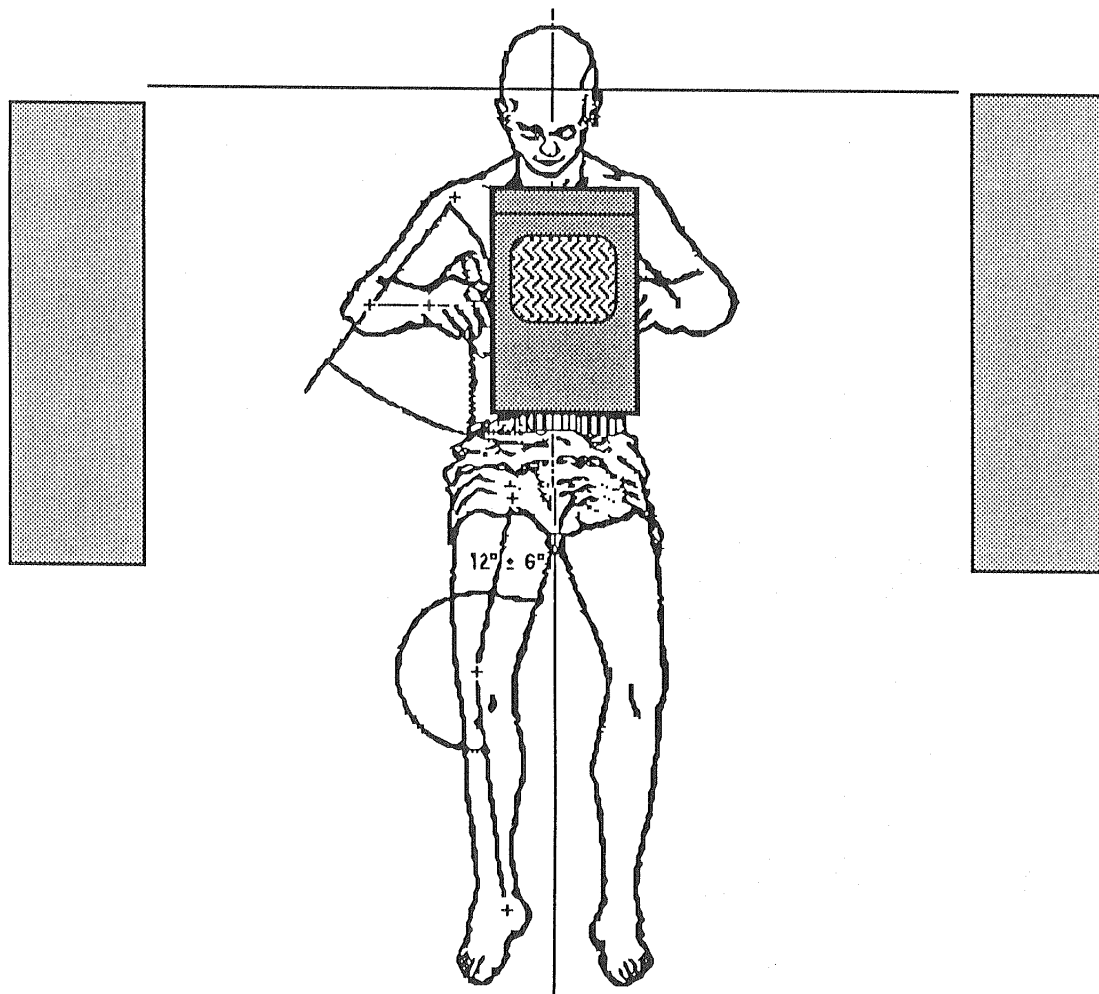
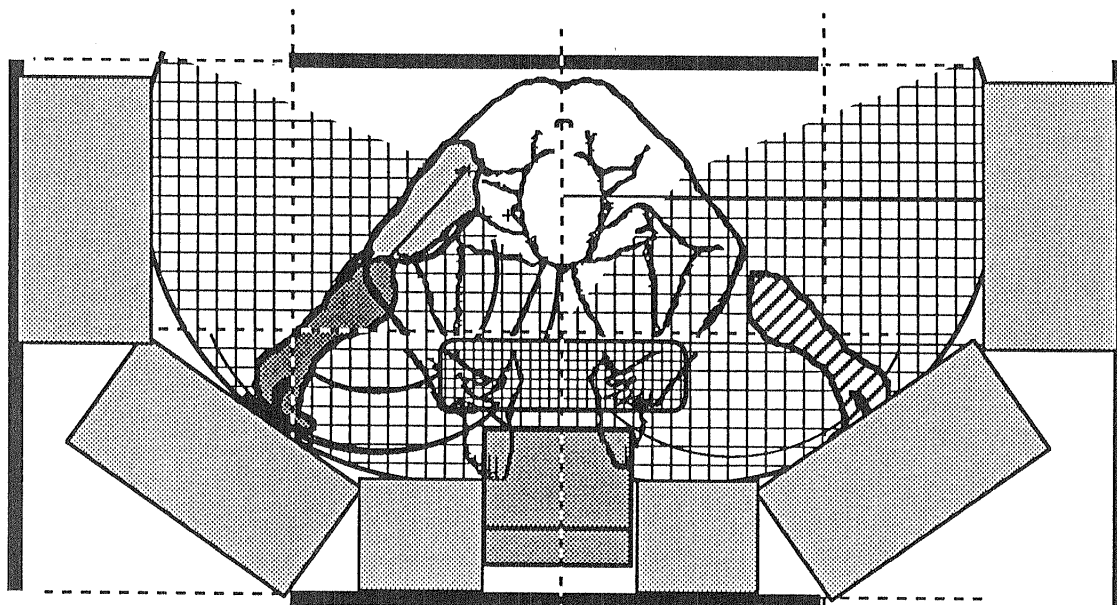
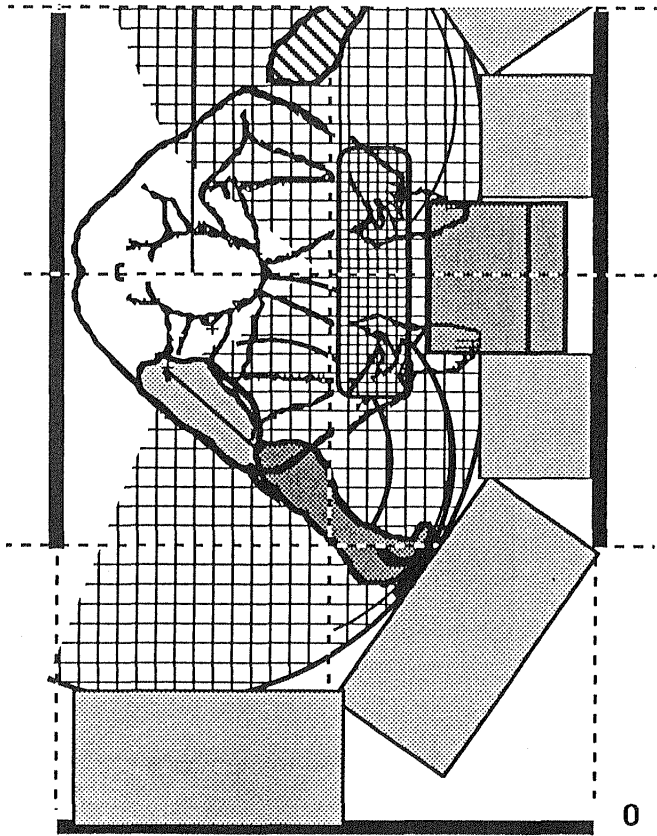

Figure 19 Top View - Engineering Workstation



SIDE VIEW

SCALE 1" = 1' - 0"

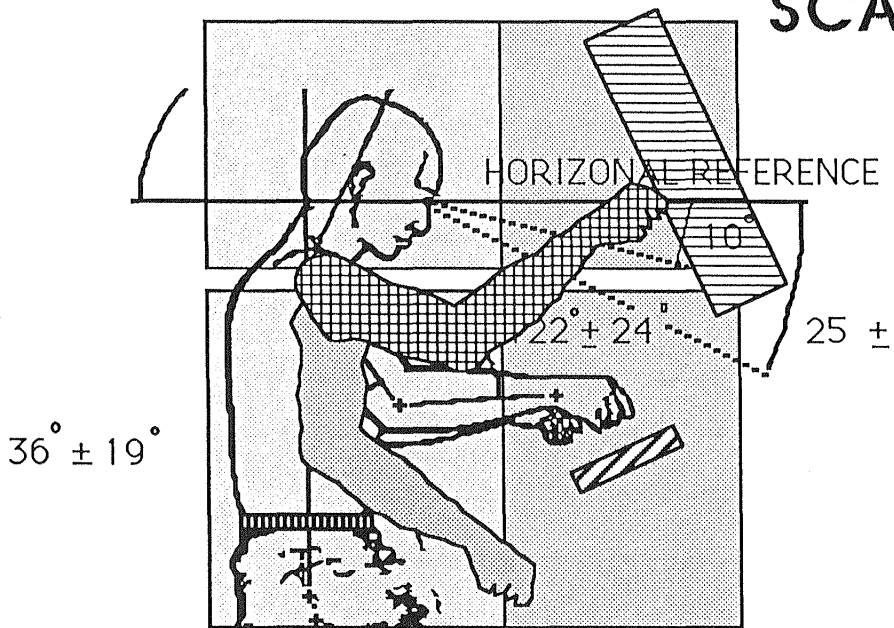

Figure 20 Middeck Sized Equipment

6. Complete privacy via lockable access.
7. Telecommunications for private flow with proprietary commercial clients.

Figures 19 and 20 depict the beginnings of such a personal workstation.

MODULE CONTROL STATION

The Module Control Station is more complicated than the crewmember personal workstation. The requirements of the Module Control Station are below:

1. Ergonomically correct for the range of individuals in the crew with some adaptability to various size and personal preferences of the users.
2. Compatibility control and similar positioning of many of the components of the environment, the equipment and personal restraints so all module control stations are similar enough to permit single training.
3. Provisions for artificial intelligence and automation of almost all functions with adequate provisions for human intervention.
4. Ten minute changeout for all components.
5. Telecommunications for public flow with NASA and commercial clients.

Figures 21 and 22 depict renderings of such a workstation.

CENTRAL BEAM OPTIONS

The "Central Beam" Concept is one of several under consideration by the Space Station program. In the Space Station Habitability Module Brief, April 4, 1985, NASA-JSC, a central beam was used with submodules attached to the utility beam to create a living environment which could be changed out through the logistics system. In a previous NASA CR 3941 contract (Ref. 2), a "Triangular Central Beam" was suggested by John Spencer. Figure 23 depicts the concept and Figure 24 pictures a rendering of the concept as used in a module.

The initial Central Beam was a triangular beam on-center. The central beam is studied in seven variations in this contract. The seven concepts include:

- 1. TRIANGULAR BEAM LOCATED ON CENTER OF MODULE**
- 2. TRIANGULAR BEAM LOCATED OFF CENTER**
- 3. SQUARE BEAM ON CENTER**
- 4. HEXAGONAL BEAM - SMALLER THAN 4 FEET**
- 5. HEXAGONAL BEAM - LARGER THAN 4 FEET**
- 6. H BEAM - LOCATED IN THE CENTER**
- 7. HEXAGONAL BEAM - MEDIUM**

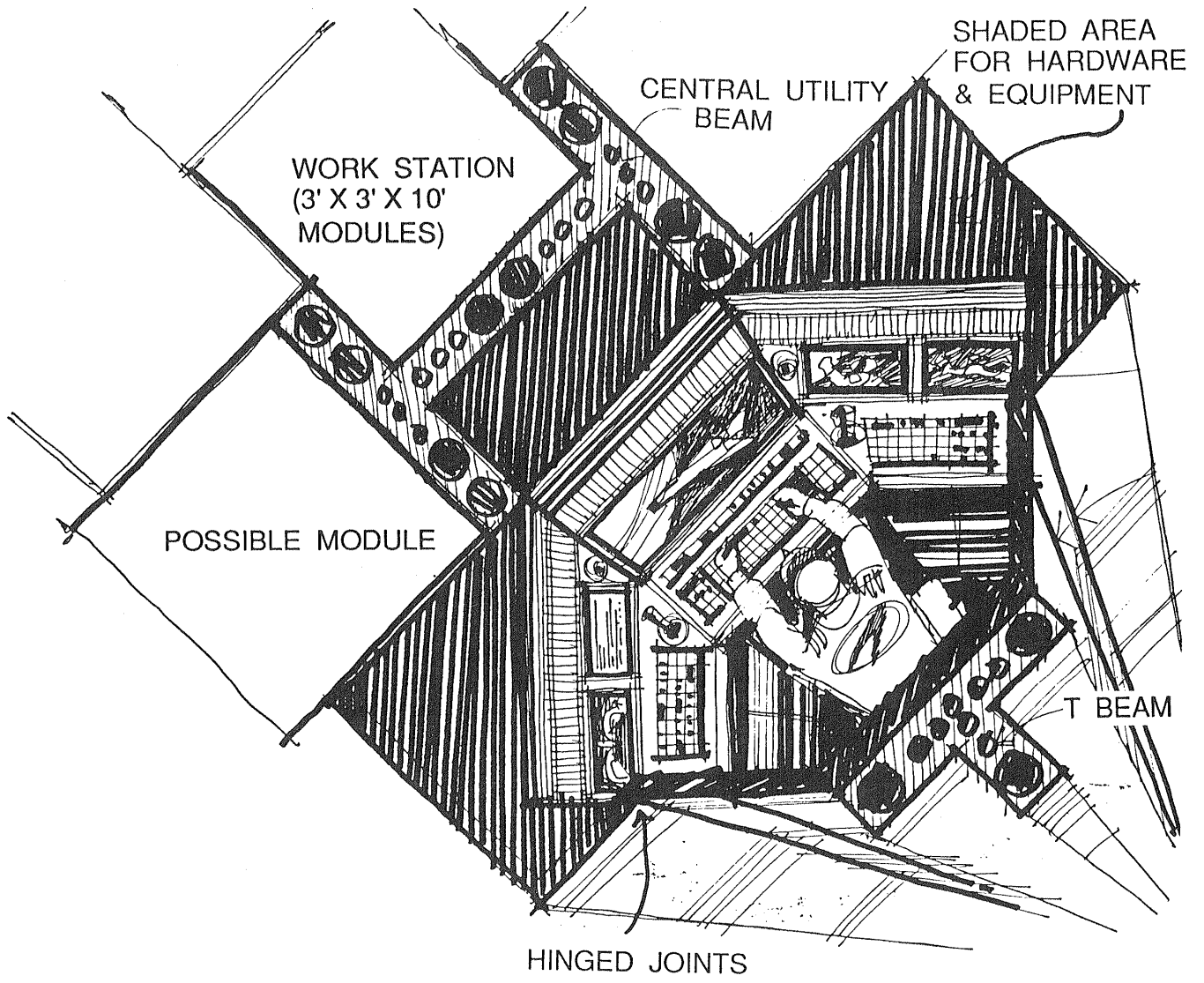

LARGE WORK STATION CONCEPT

Khan '85

Figure 21 Module Control Station

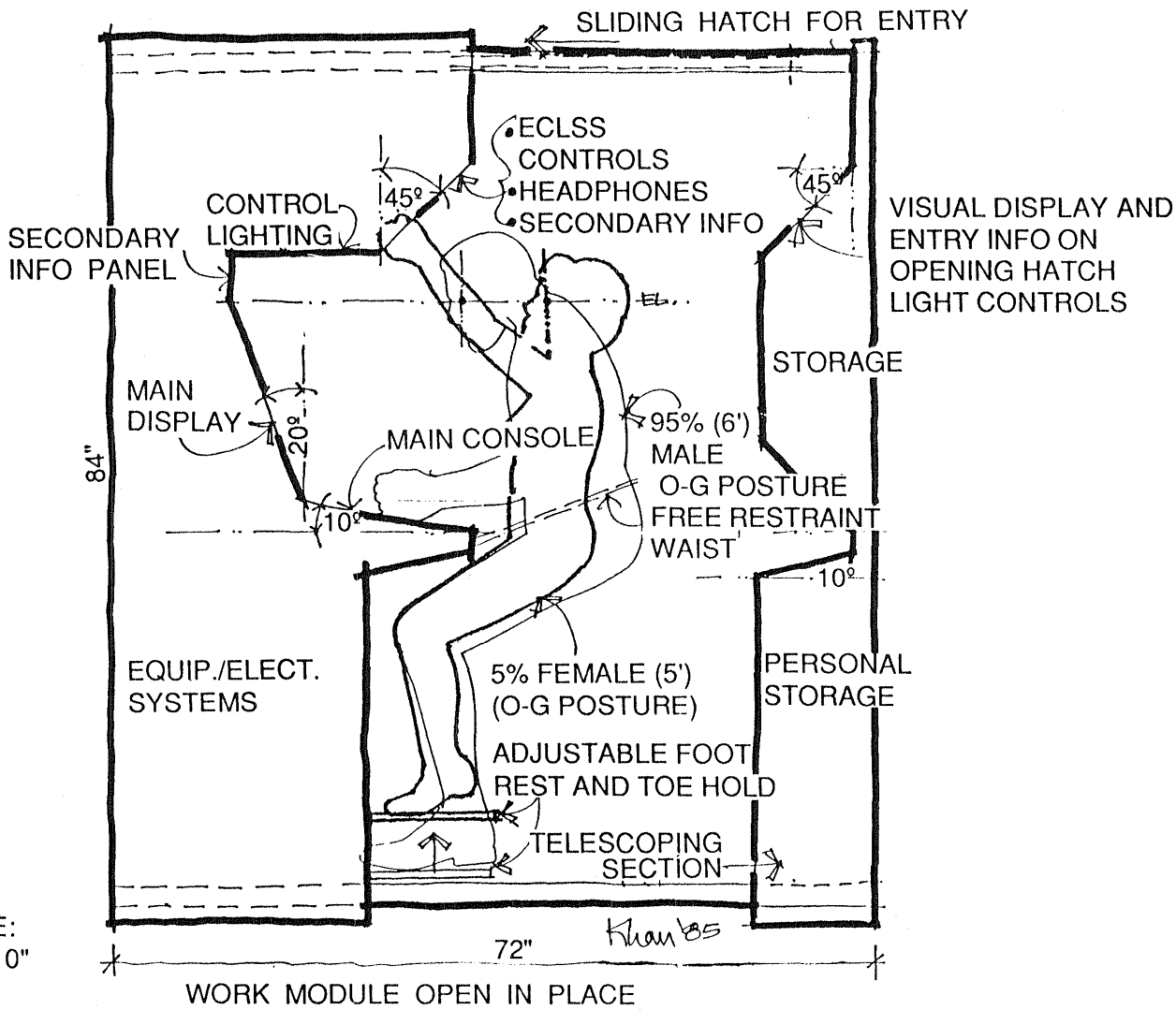

SCALE:
1" = 10"

BASIC
ANTHROPOMETRIC
DATA = (U.S.)

MALES: 97.5% = 6'2"
50.0% = 5'9"
2.5% = 5'4"

FEMALES: 97.5% = 5'9"
50.0% = 5'4"
2.5% = 4'11"

Figure 22 Module Control Station Details

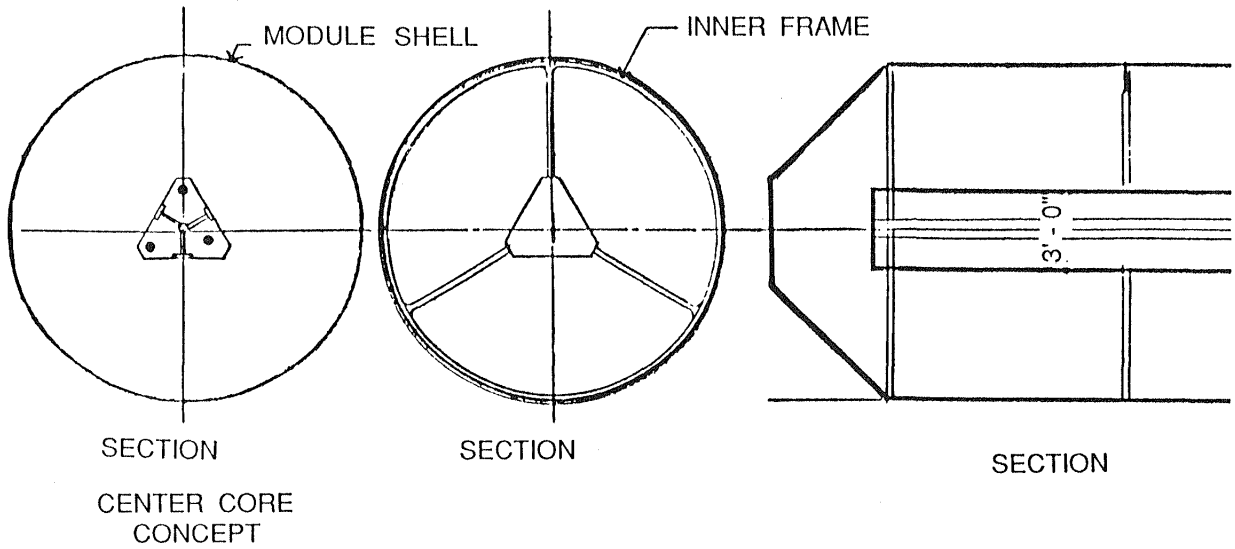

CENTER UTILITY CORE CONCEPT

NOTE: The structure of the core will be sufficiently strong for the launch loads.

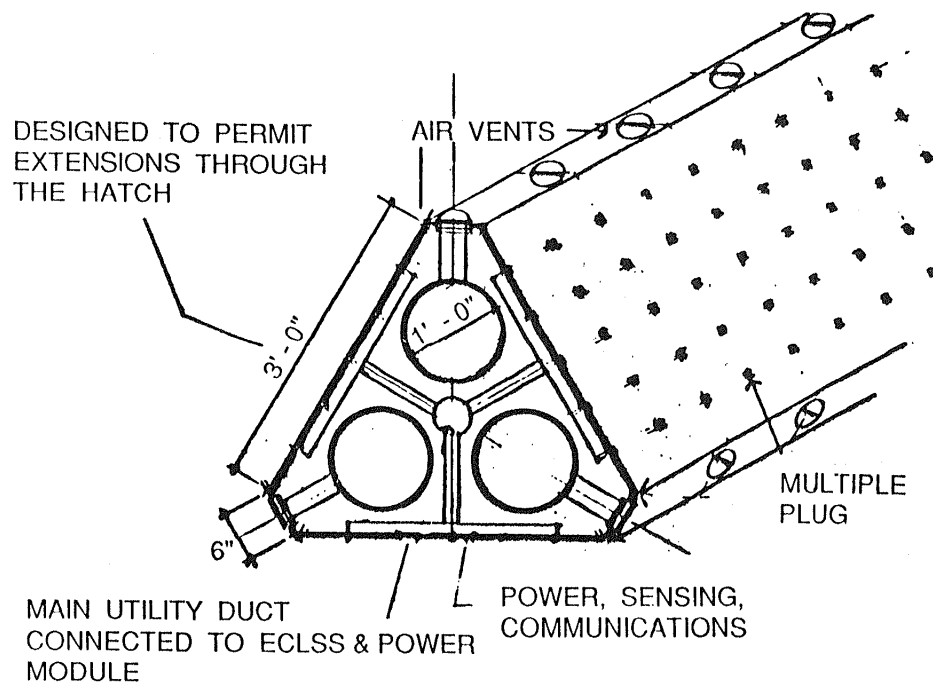

Figure 23 Original Triangular Central Beam Concept

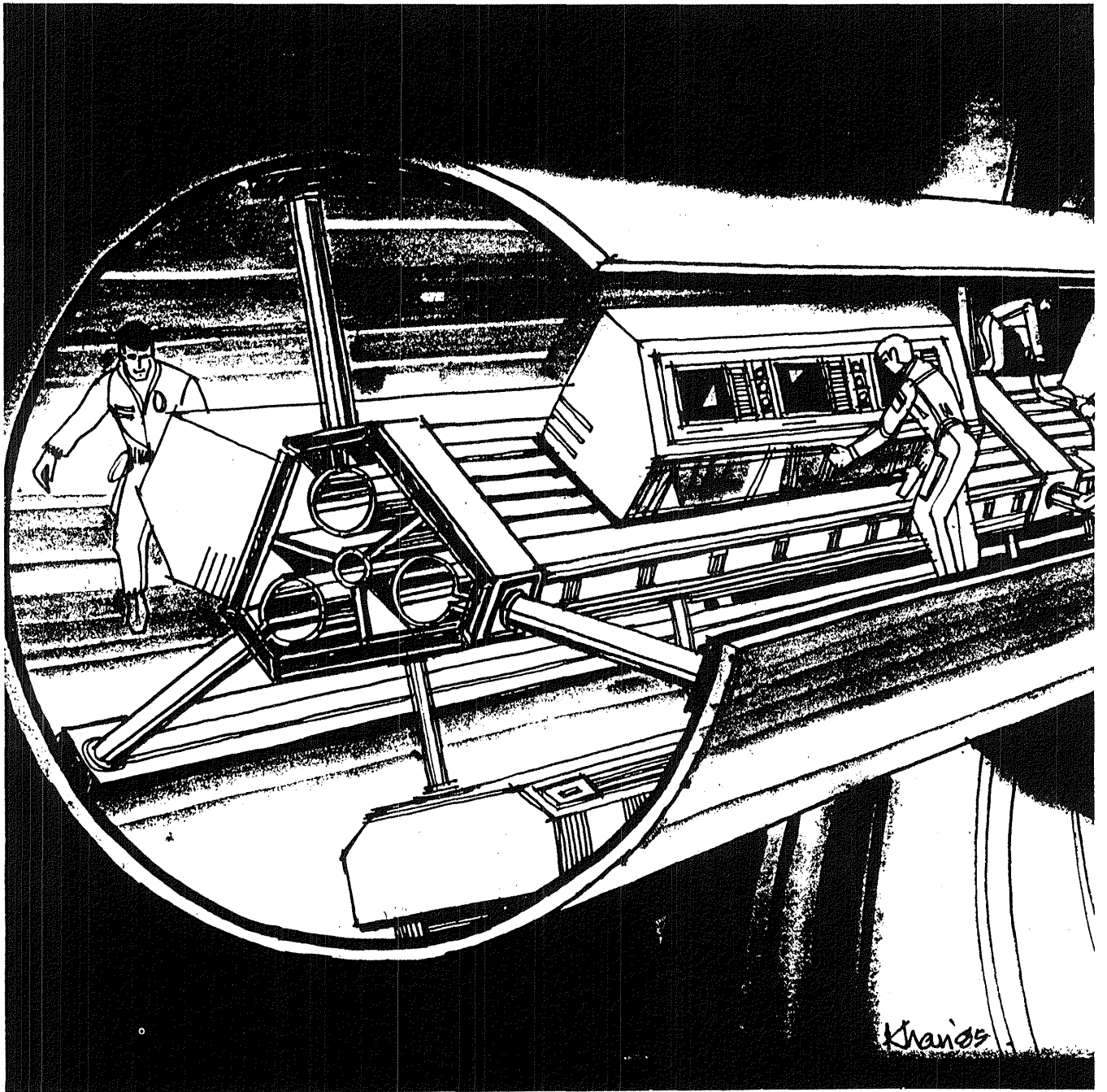

Figure 24 Triangular Central Beam in Module

Seven beam configurations were constructed and documented. A methodology for identifying, selecting and implementing a design criteria for evaluating the beam sections is suggested, but full evaluation must be pursued on an incremental feed back basis. The goal of the suggested criteria is an evaluation tool prototype which is adaptable to several different kinds of Space Station Interior Architecture and flexible enough to be user modified. The seven beam configurations researched in this contract are shown in Figure 25.

The spatial effect of the utilities required in the Space Station appears to be significant. Previous remote bases indicate the initial design and long term maintenance are critically important to the success of the Space Station. For example, the temporary and permanent utilities turned out to be a large manhour maintenance and repair item in the overhead labor budget in Alaska (Refs. 3 and 4).

PRELIMINARY UTILITY ESTIMATE

Early estimates of the utilities required have been extracted from NASA Space Station documents (Ref. 5). It should be noted that the author has supplemented the utilities to reflect maintenance and long term repair considerations. These additions include a 6" vacuum line for several reasons and adapted to combat future problem areas. The diameter of the line is six inches and designed to act in emergency situations as a cleanup vacuum discharge line for water, toxic cleanup, gray water cleanup and potentially waste removal. Microgravity offers some new problems and dictates new rules of thumb over and above normal health and safety considerations normally associated with surface utility design and fabrication/construction.

The Space Station utilities are amplified to include some beam type refinements. Figure 26 illustrates the utilities assumed for the conceptual beam configurations researched in this study. Some utility lines such as the vacuum line are not extended through the hatch as shown in rough form in Figure 27. A typical layout of utilities is shown for the Triangular Beam configuration in Figure 28. Some of the lines are assumed to be loops within the individual modules for technical and maintenance reasons. Figures 29, 30 and 31 assume the ECLSS equipment required as standard within an individual module. It represents only a rough estimate to get a rough volumetric total and is not based on any NASA technical data.

TRIANGULAR BEAM ON CENTER

The triangular central beam placed in the center of the module is depicted in Figure 32. The beam is an isosceles cross-section which divides the volume bounded by the circular module walls, but appears to be less efficient when compared to the equilateral beam section shown in Figure 33. This figure illustrates three equal volumes with potentially different activities. It could, for example, offer a degree of commercial proprietary capability in a future lab module.

Application of the Triangular Beam section can take several directions. The beam and beam support member can subdivide the module volume and provide habitation volumes as shown in Figures 34 through 41. The interior equipment module assumptions are shown in Figure 42. The packing density suffers with such use. Other designs later address the density and increase the packing densities. Packing densities may not be a heavily weighted evaluation factor in the habitation modules.

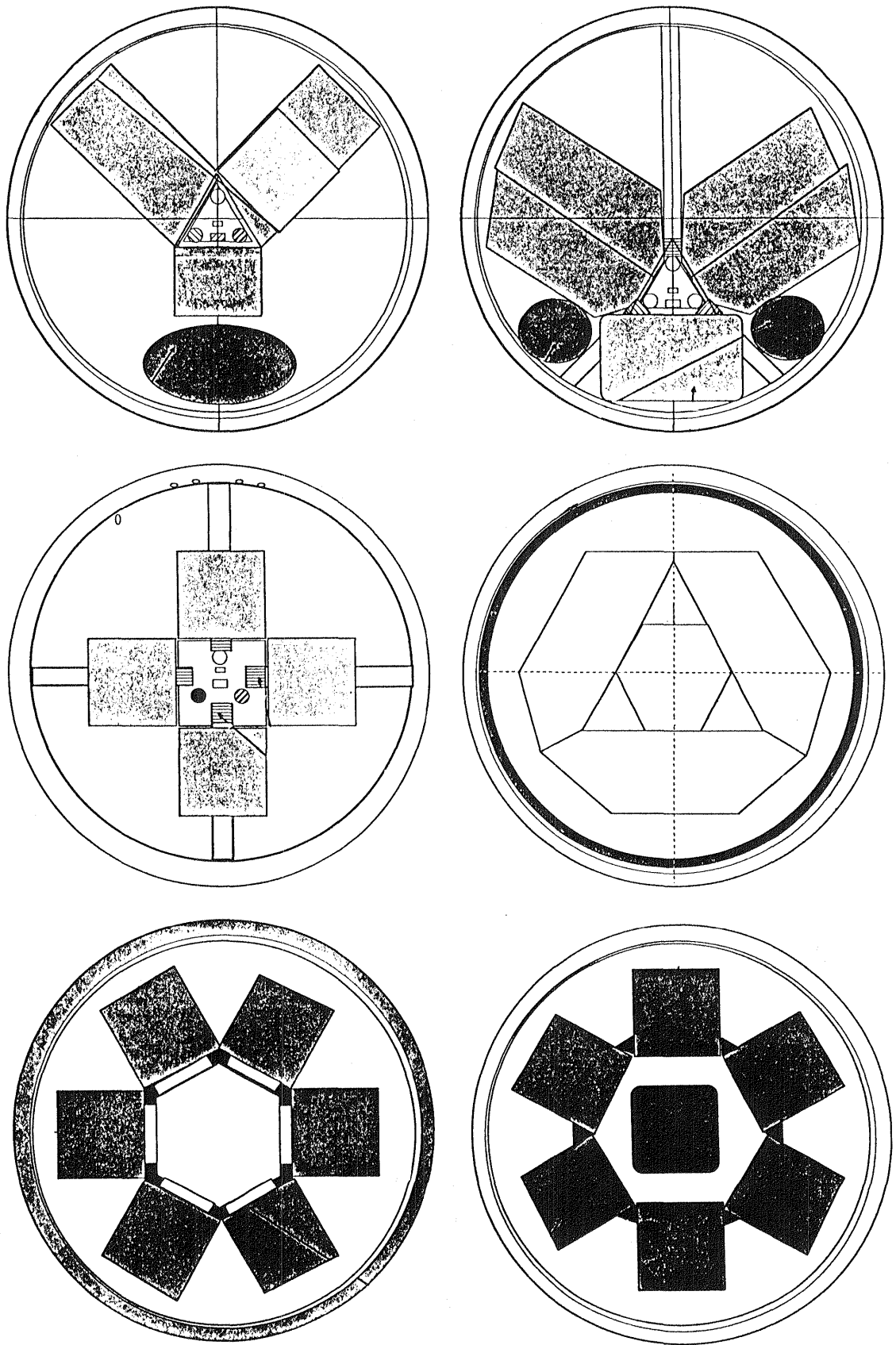

Figure 25 Six Beam Configurations

UTILITIES

SEE JSC-19989, P. 110 FOR BRAKDOWN, EXCLUDES 30% GROWTH,
AUTHOR'S ESTIMATES ARE IN BOXES =

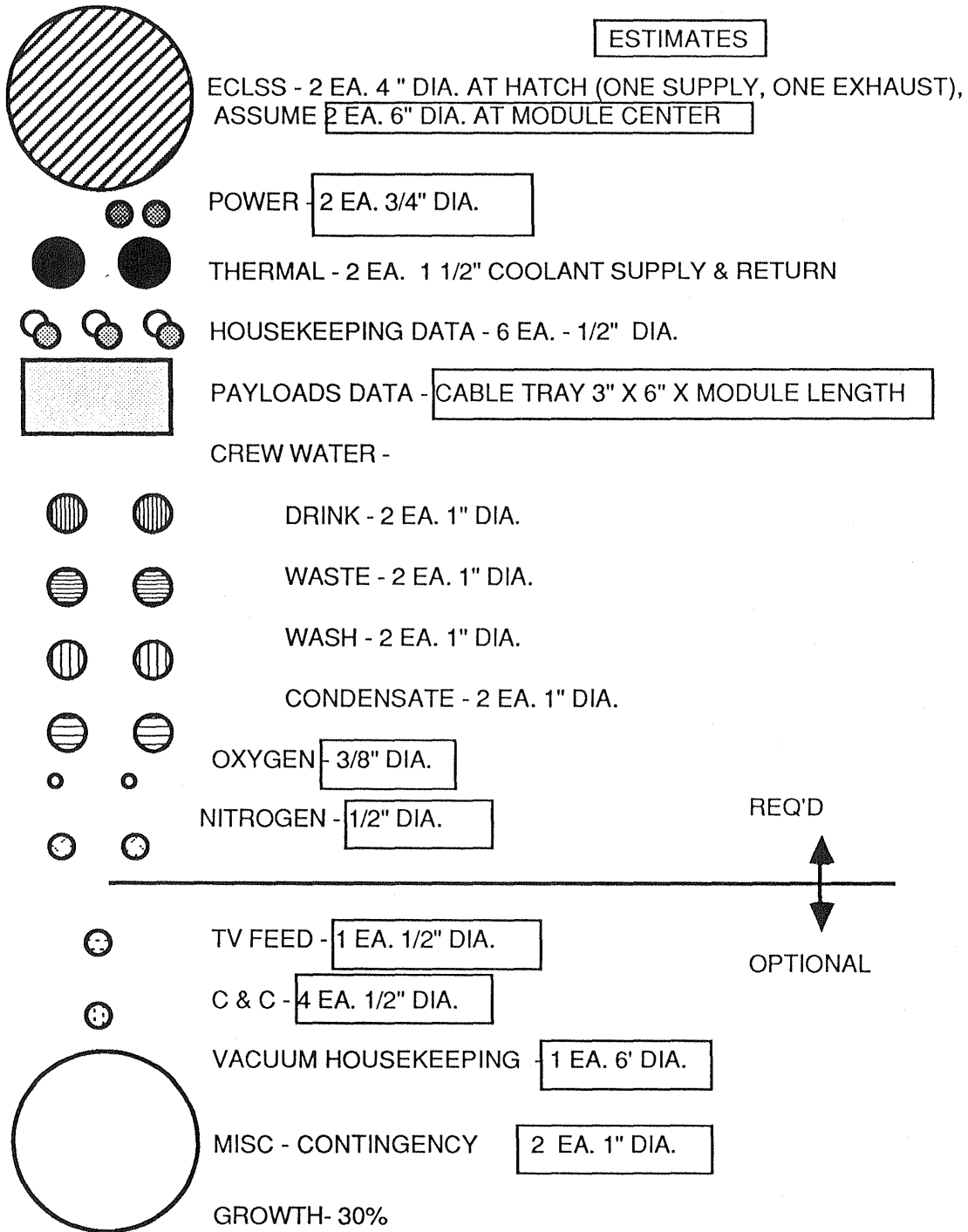
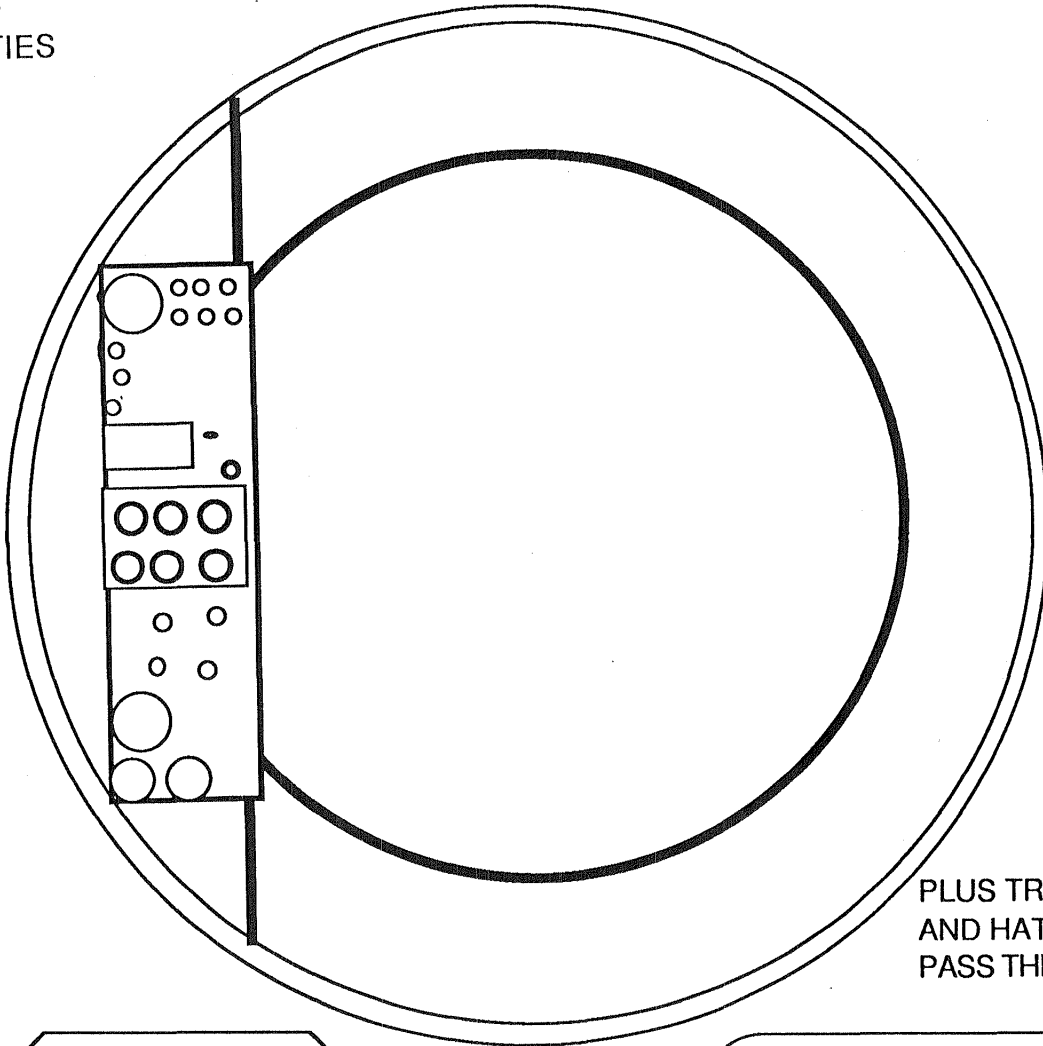

Figure 26 Assumed Utilities

50 INCH
HATCH WITH
BOXED
UTILITIES



PLUS TRANSITIONS
AND HATCH
PASS THROUGHS

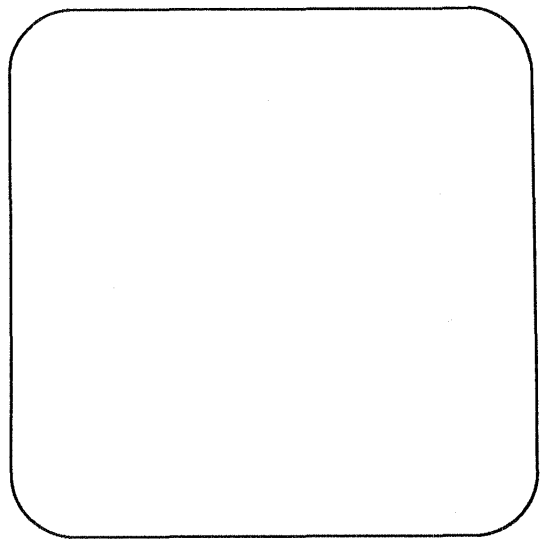
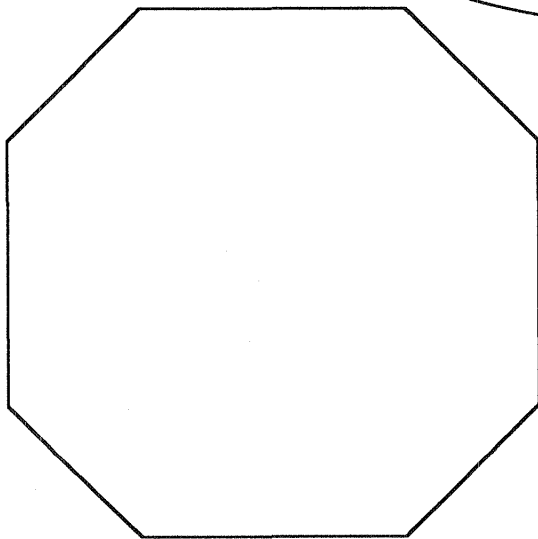
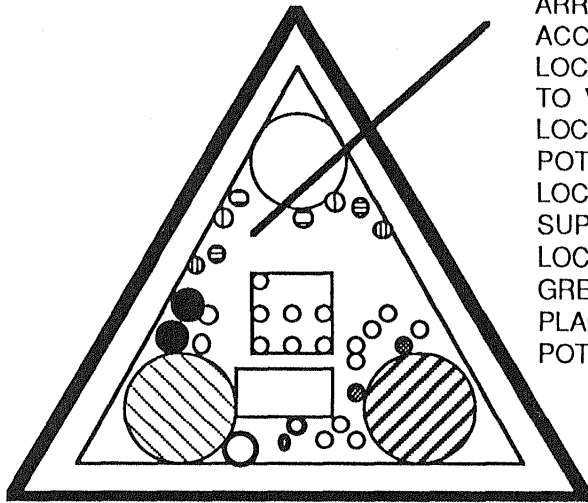

Figure 27 Hatch Assumption

UTILITY PLANNING

TRIANGULAR CENTRAL BEAM



- ARRANGE CONNECTOR LINES NEAR OUTSIDE ACCESS PLATES.
- LOCATE POTENTIAL LIQUID LEAK LINES NEAREST TO VACUUM DISCHARGE LINE.
- LOCATE ELECTRICAL LINES FURTHEST FROM POTENTIAL LEAK LINES.
- LOCATE FIRE POTENTIAL AWAY FROM CUMBUSTION SUPPORT SOURCES.
- LOCATE FRESH WATER FURTHER FROM VACUUM THAN GREY WATER LINE.
- PLACE SENSORS IN ALL THREE CORNERS FOR POTENTIAL TRIANGULATION OF UTILITY PROBLEM.

EQUILATERAL

7.3 CF ECLSS
 35.3 CF OPTICAL, ETC.
 17.6 CF INTERNAL UTIL.
 10.8 CF HAB

71.0 CF REQUIRED

INTERNAL VOLUME

VOLUME W/O 1" 1/2" STRUCTURE

= 2.85 CF X 27" = 77 CF AVAILABLE

PLUS TRANSITIONS AND HATCH PASS THROUGHES



SCALE

1" = 1' - 0"

Figure 28 Utility Volume Estimate

UTILITY DESCRIPTIONS

SCALED INTERNAL DIAMETER

ESTIMATES

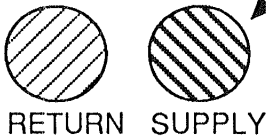

AIR FLOW 2 EA. 6" WITH SLIGHT PRESSURE GRADIENT FROM THE SUPPLY TO RETURN TO PROVIDE FLUID LEAK CONTROL, 6" VACUUM LINE INLETS CAPABLE OF ACTIVATION EVERY FOOT. CLEANING VIA RABBIT OR "CLEANING PIG" USING PRESSURE/VAC. OPERATION. THE SUPPLY FORCES "CLEAN AIR" OUT THE SUPPORT BRACE TOWARD THE MODULE PRIMARY SHELL SURFACE WITH A RETURN TO THE INLET AT THE MODULE CENTER. TWO ECLS EQUIPMENT UNITS =

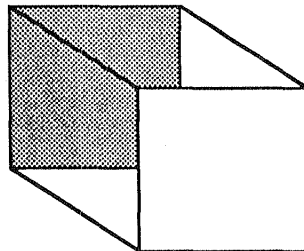
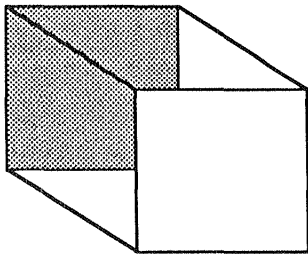

3' SUB MODULE
NOT TO SCALE

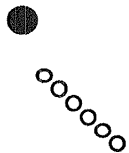
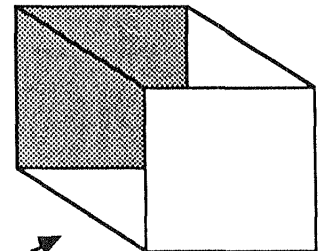

THERMAL - 2 EA. 1 1/2" COOLANT SUPPLY & RETURN UNIT EXCHANGER INCLUDING 1/4 INSULATION. PLACE DOUBLE VALVES AT EACH 9 FOOT BEAM JOINT WITH TWO PUMPS PER MODULE

HOUSEKEEPING DATA - 6 EA. - 1/2" DIA. BUNDLE



POWER - 2 EA. 3/4" DIA. WITH 2 CF LOAD CELL EVERY 9 FOOT SECTION.

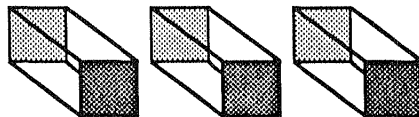

NOT TO SCALE



PAYLOADS DATA CABLE TRAY 3" X 6" X MODULE LENGTH

- 1.
- 2.
- 3.
- 4.
- 5.
- 6.

Figure 29 ECLS Volume Estimate (1 of 3)

CREW WATER -

ASSUME ONE DRINKING WATER UPGRADING UNIT PER MODULE OR 27 CF, ONE FRESH WATER TANK 3' DIA. (GAL.), ONE WASTE WATER TANK 3' DIA., ONE WASH WATER OR GRAY WATER SYSTEM WITH 3' DIA. TANK, ONE SEWAGE TO WASH WATER UPGRADING UNIT (TWO STAGE PROCESS TO DRINKING WATER) 3' CUBE, AND DOUBLE SHUT OFF VALVES AT EACH 9 FOOT CONNECTION.

- | | | |
|---|---|----------------------------|
| ⊕ | ⊕ | DRINK - 2 EA. 1" DIA. |
| ⊖ | ⊖ | WASTE - 2 EA. 1" DIA. |
| ⊙ | ⊙ | WASH - 2 EA. 1" DIA. |
| ⊚ | ⊚ | CONDENSATE - 2 EA. 1" DIA. |

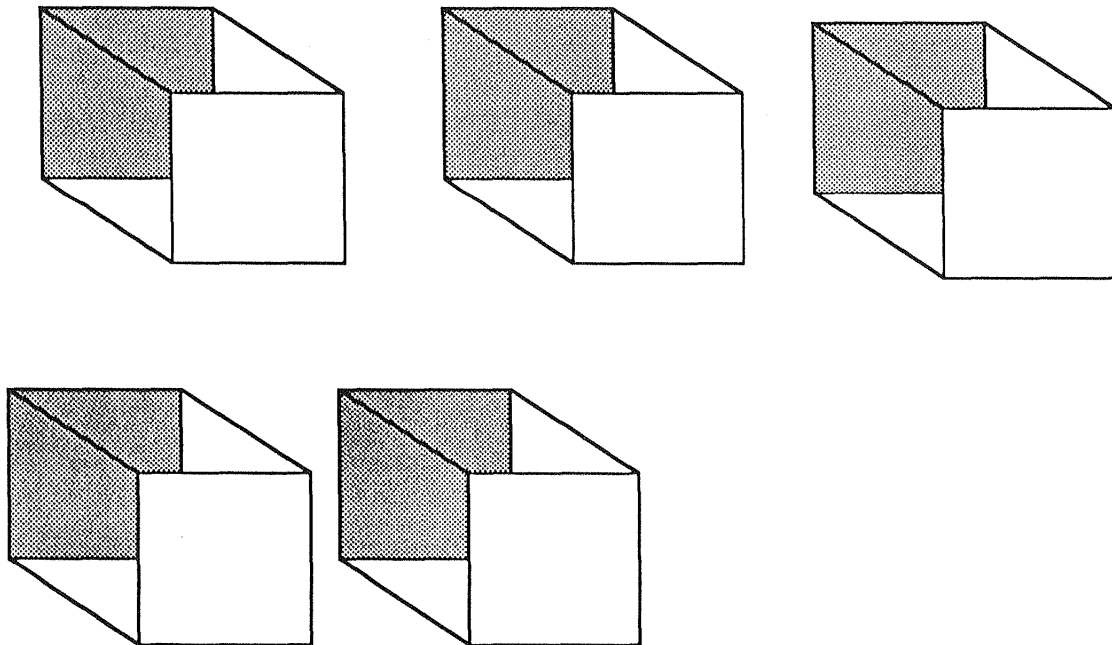

Figure 30 ECLS Volume Estimate (2 of 3)

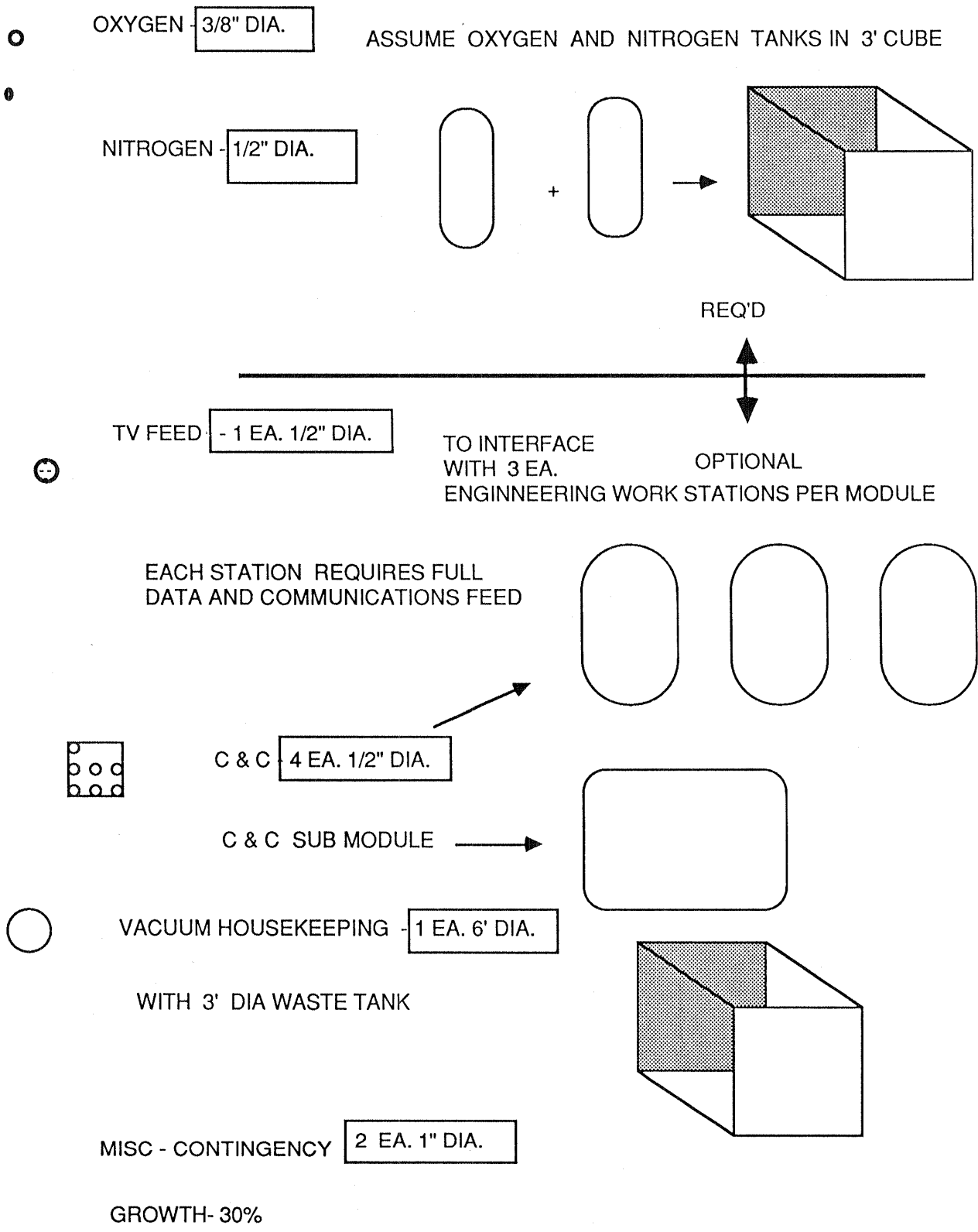
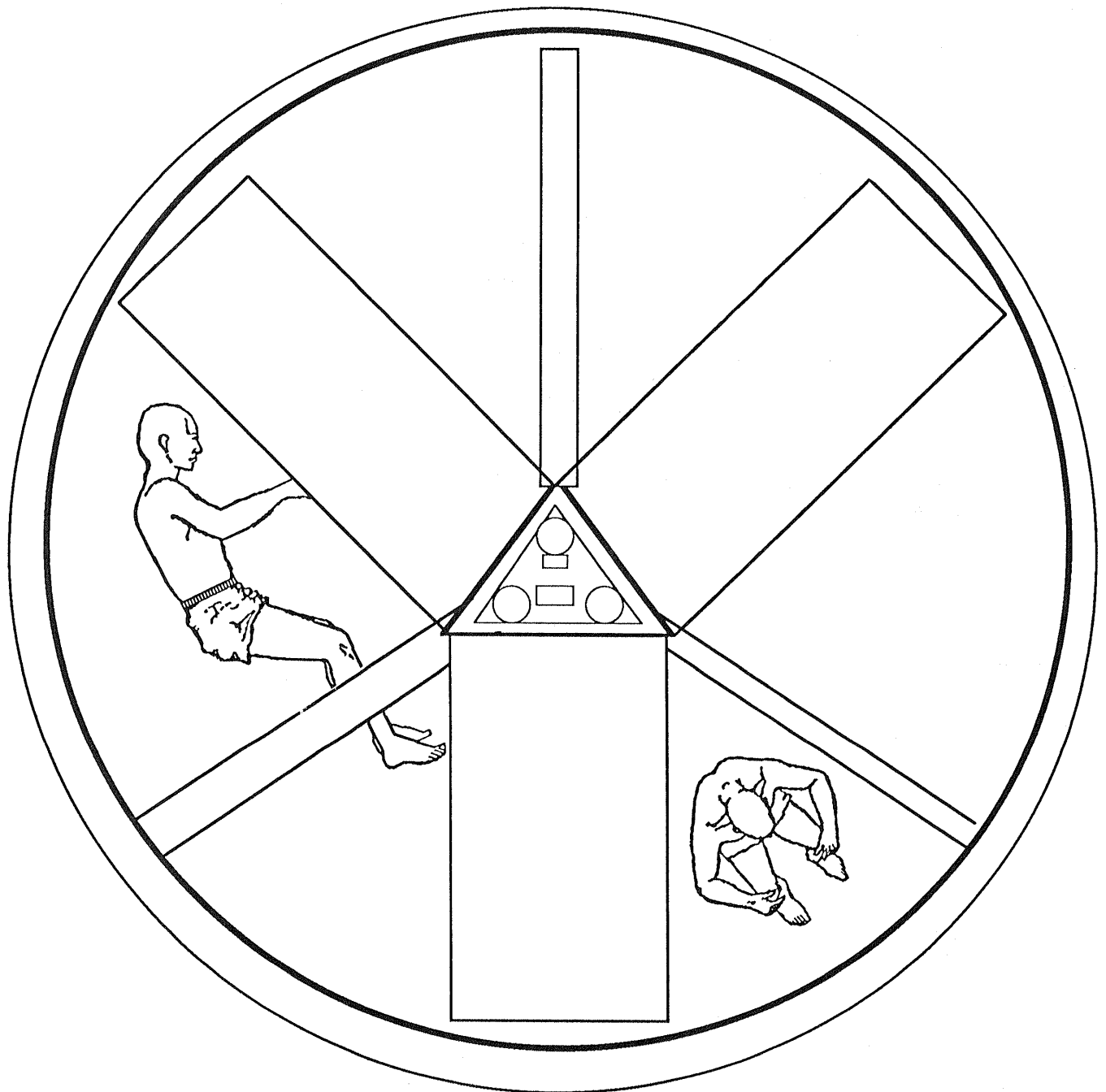

Figure 31 ECLS Volume Estimate (3 of 3)

TRIANGULAR BEAM

ON CENTER



SCALE

Figure 32 Triangular Beam - On Center

3 FOOT SUBMODULES

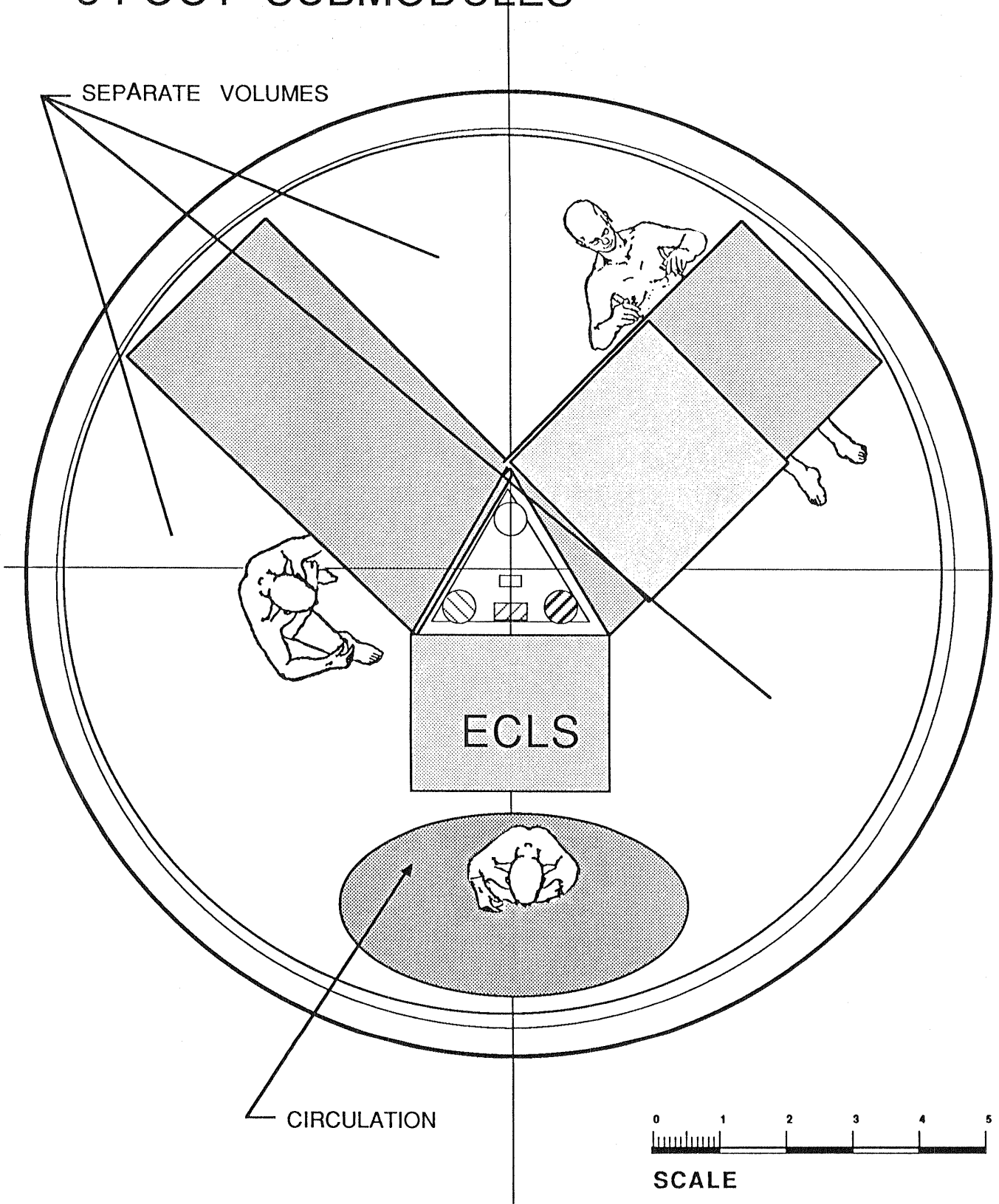
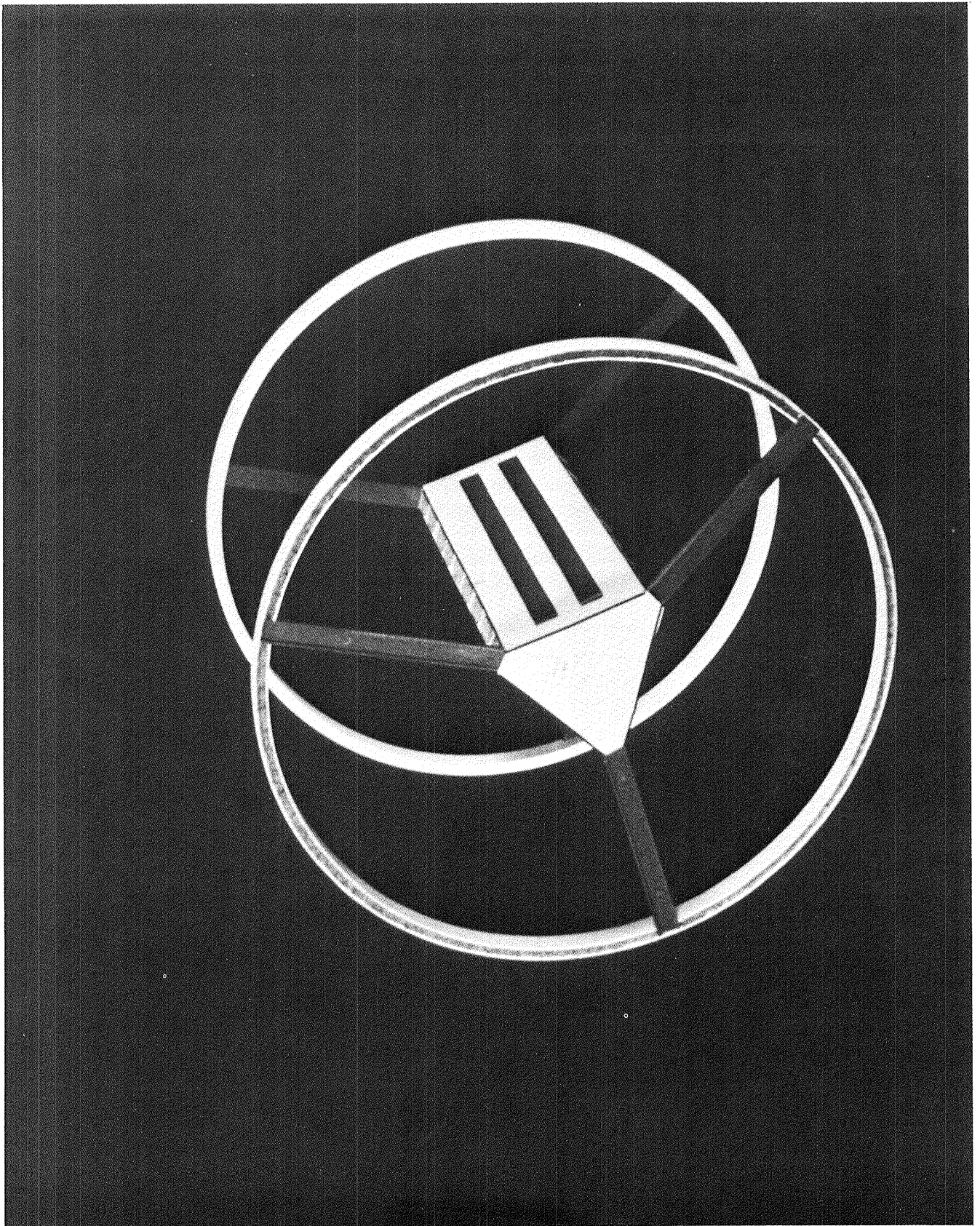

Figure 33 Equilateral Triangular Beam - On Center

TRIANGULAR INSERT FOR THE CENTER OF THE MODULE

Photograph-4 depicts the Triangular Central Beam located in the center of the module. It uses an outer ring which contains air circulation ducts, lighting fixtures and other items such as cameras and sensors which require displacement from the central core of equipment to be effective. The center core is structurally attached to the module exterior skin by three radial members containing air flow ducts and wiring.



Photograph-4 Triangular Beam Insert for the Center of the Module

TRIANGULAR BEAM LOCATED ON CENTER OF THE MODULE

Photograph-5 shows the Triangular Beam insert positioned within the NASA furnished clear plastic scaled module. The scaled human is positioning the beam. The concept allows the common module to be launched without any interior mass and the entire interior system is transported to orbit in a separate dense packed transport module or logistics module. The ability to pass everything in the interior through the hatch will insure the envisioned 2.5 change outs of the entire contents is possible.

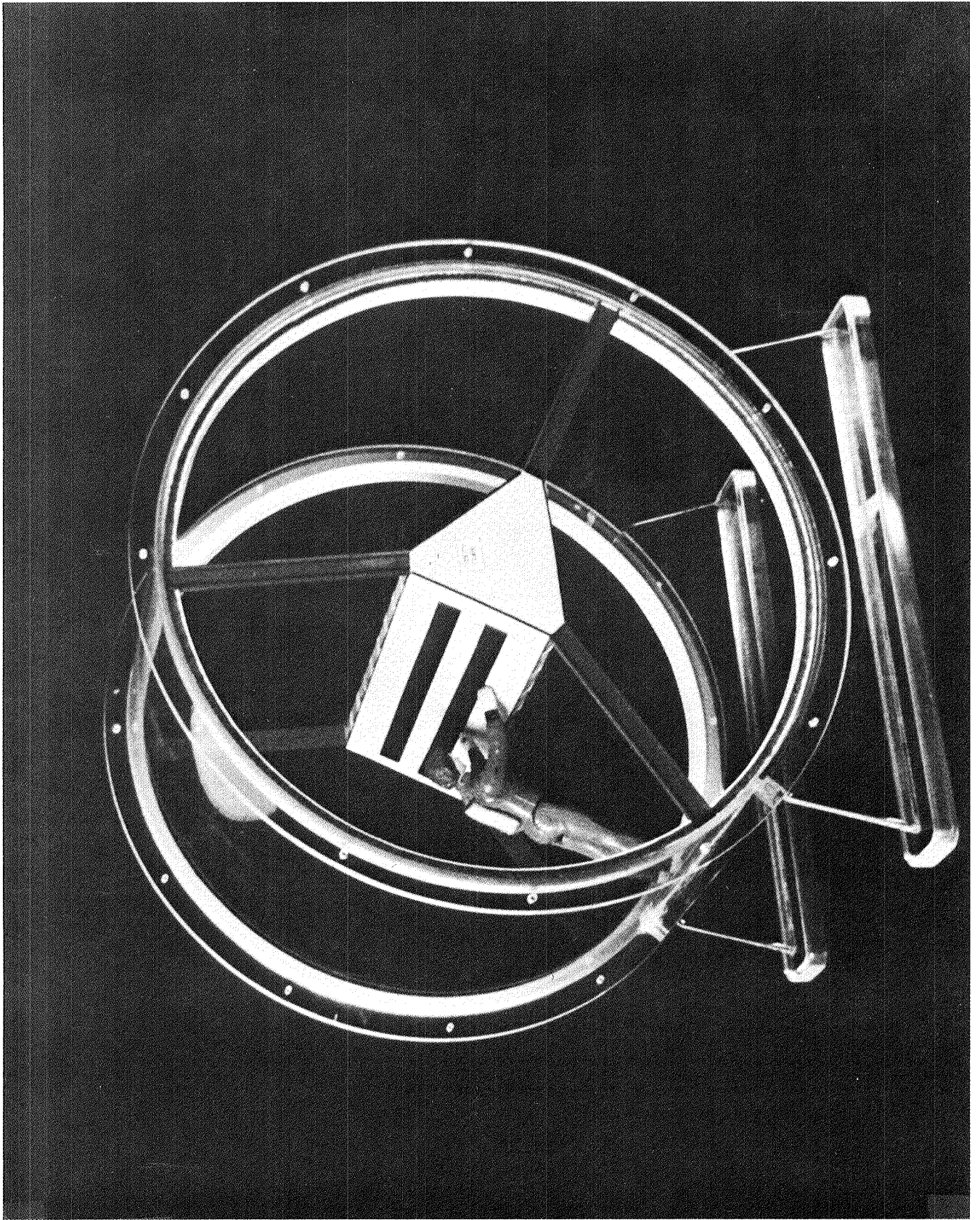

Photograph-5 Triangular Beam Insert With Human Form

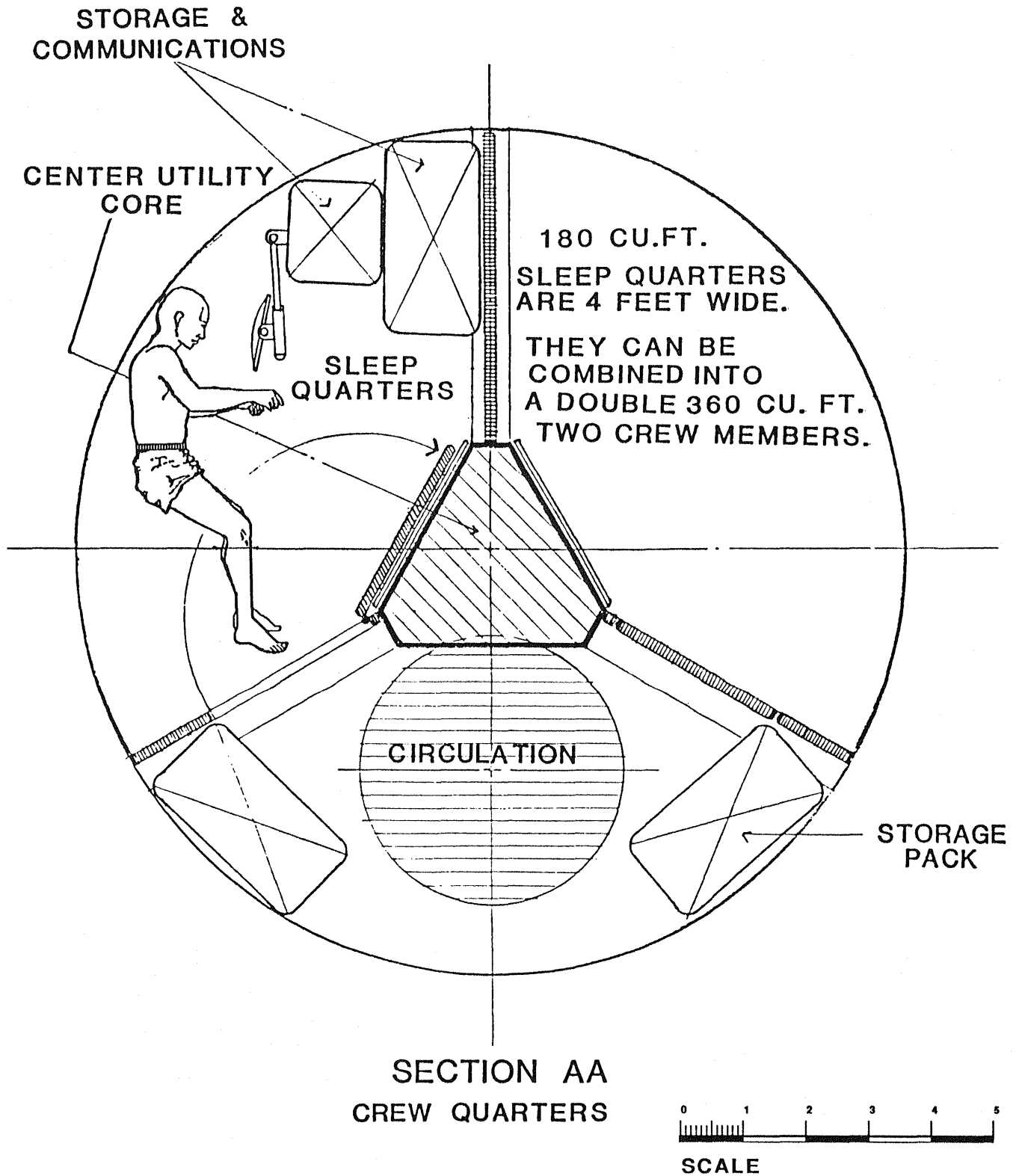
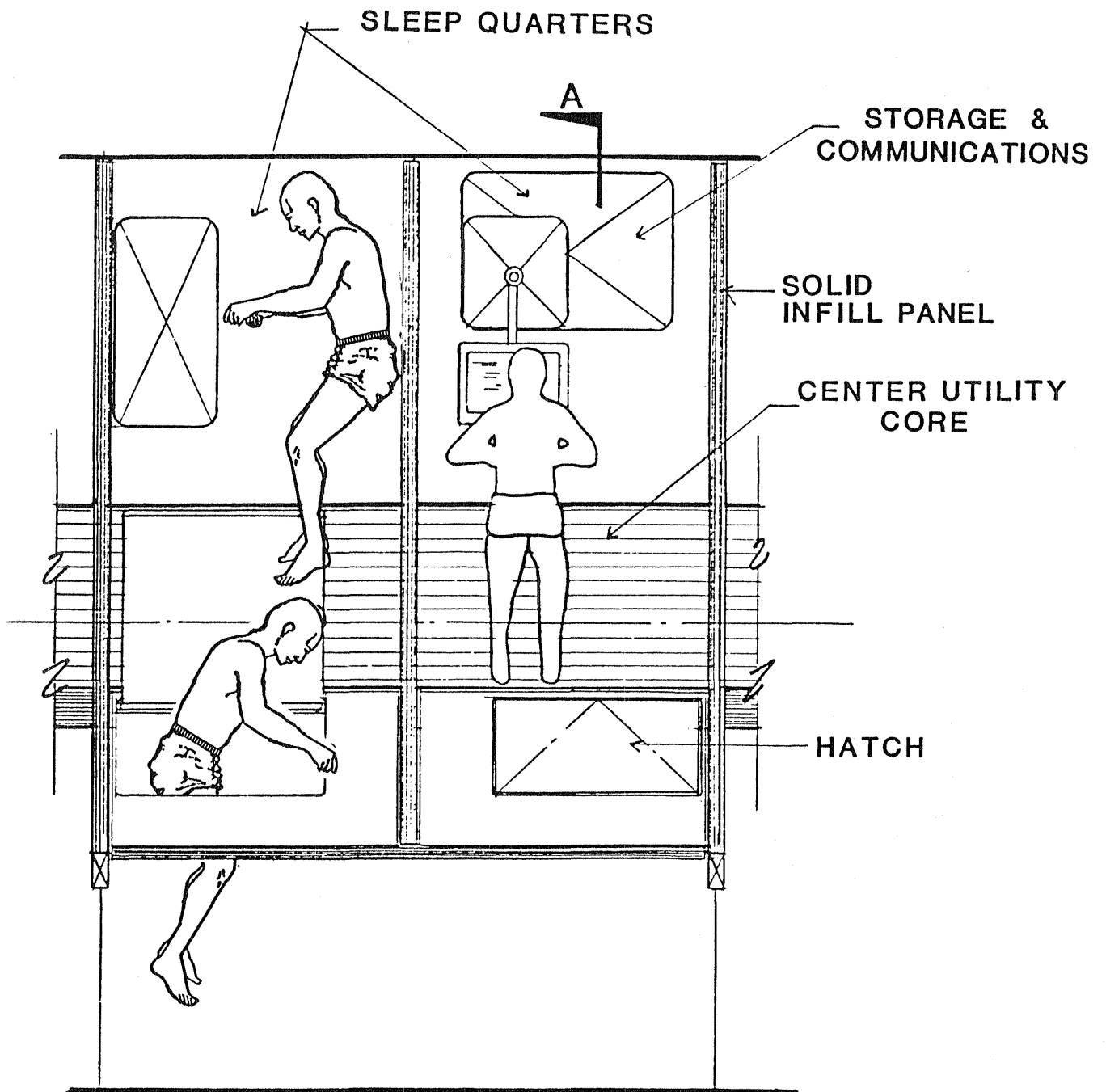

Figure 34 On Center Triangular Beam Application (1 of 6)



LONGITUDINAL SECTION



SCALE

Figure 35 On Center Triangular Beam Application (2 of 6)

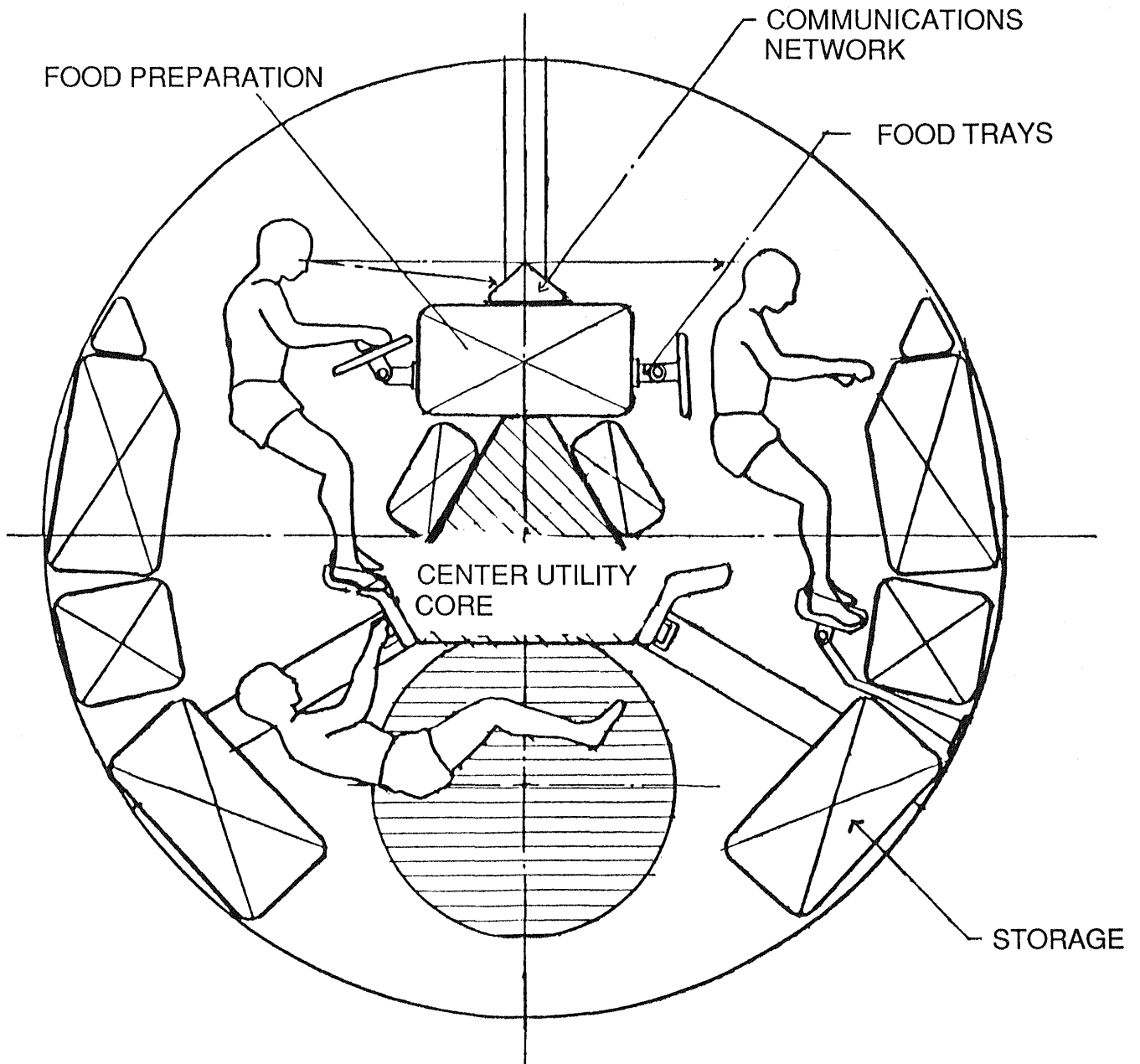

TRANSVERSE SECTION
CREW GALLEY CENTER DESIGN

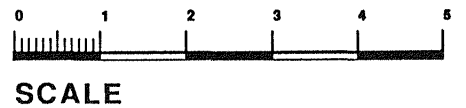
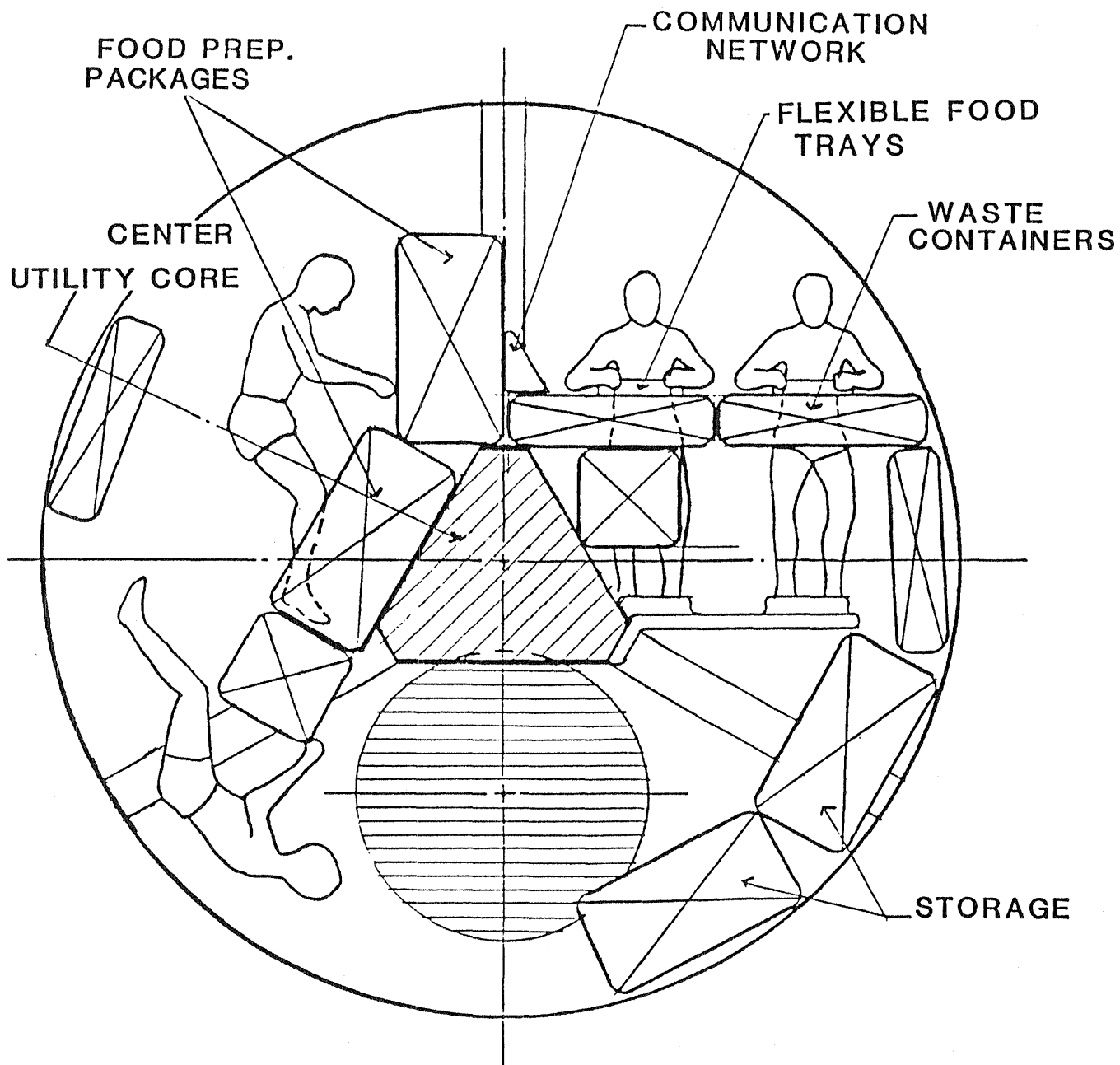

Figure 36 On Center Triangular Beam Application (3 of 6)



SECTION AA
 CREW GALLEY OFF CENTER DESIGN

Figure 37 On Center Triangular Beam Application (4 of 6)

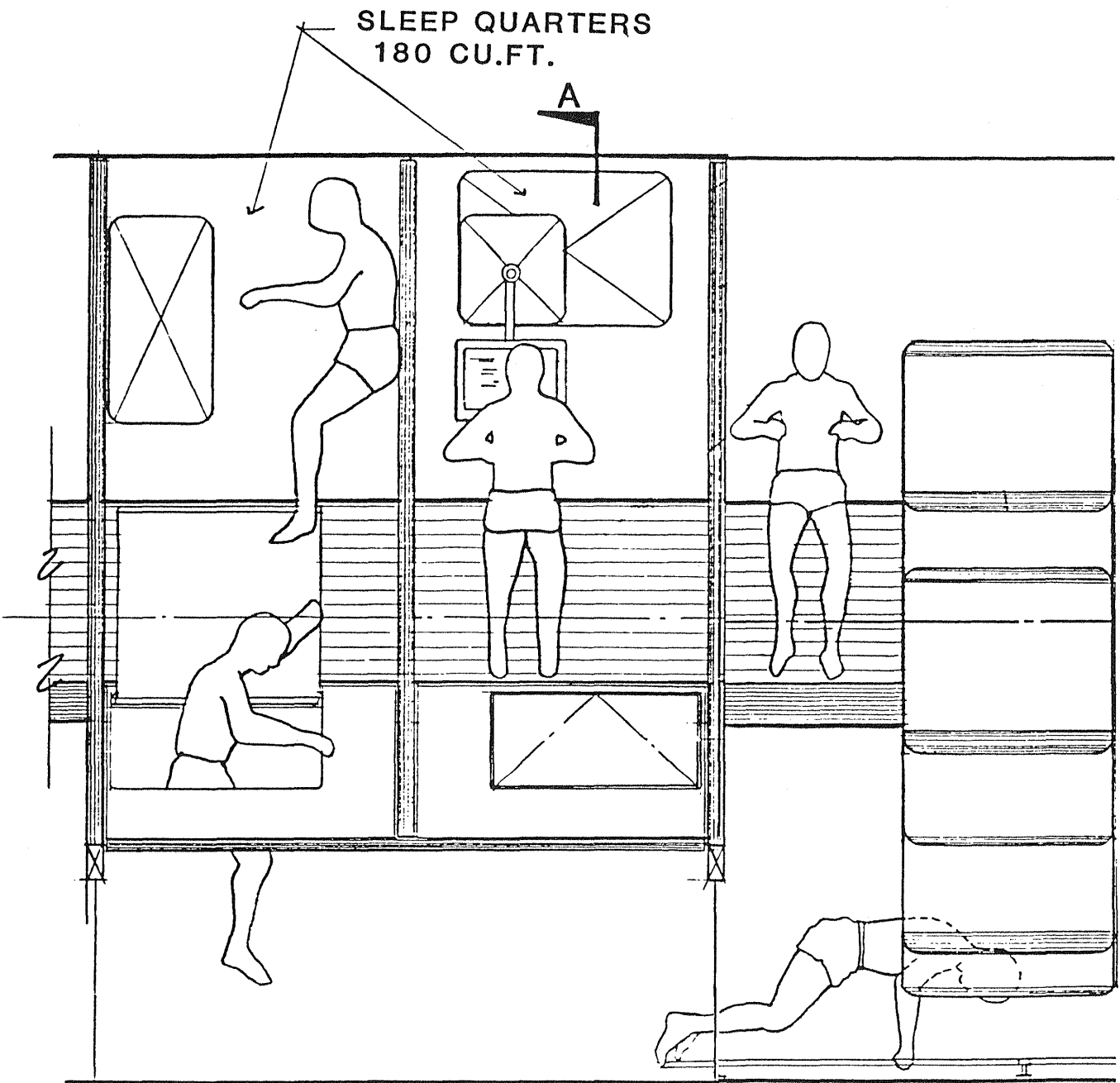

Figure 38 On Center Triangular Beam Application (5 of 6)

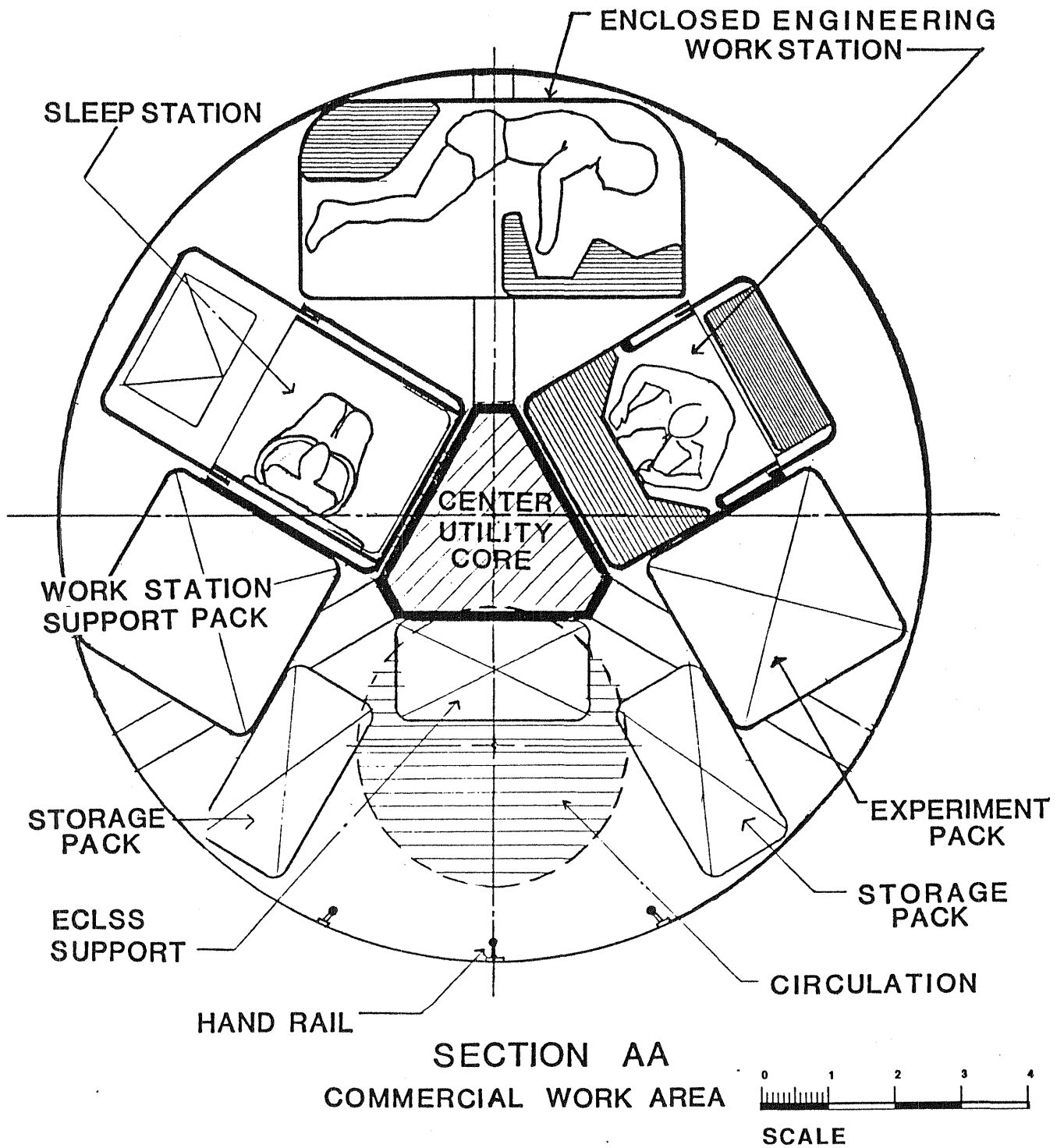

Figure 39 On Center Triangular Beam Application (6 of 6)

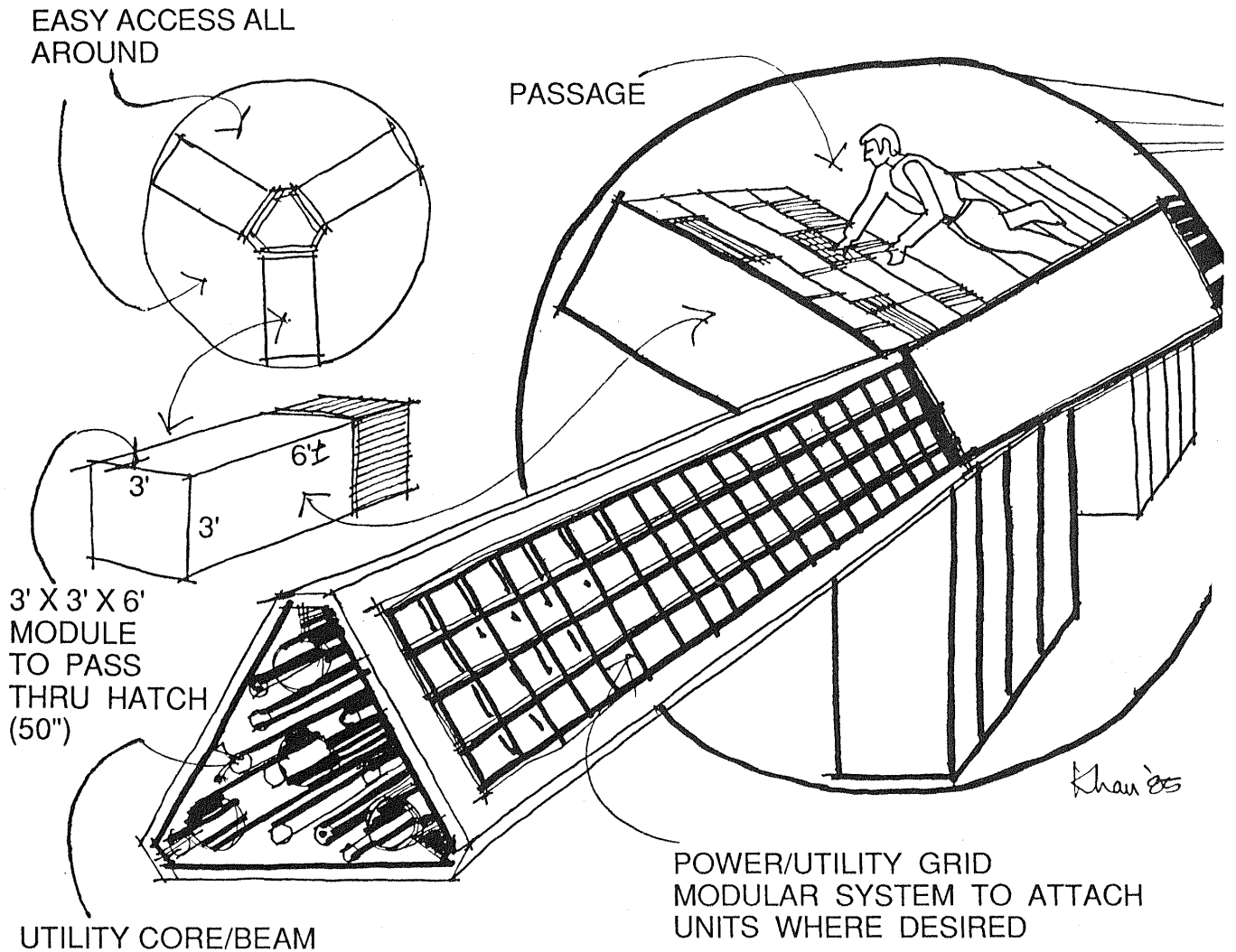

Figure 40 On Center Triangular Beam Renderings

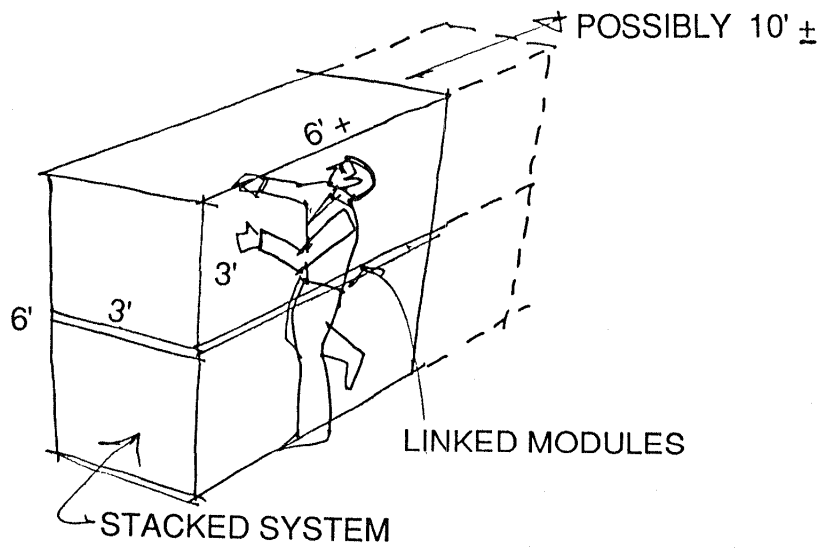
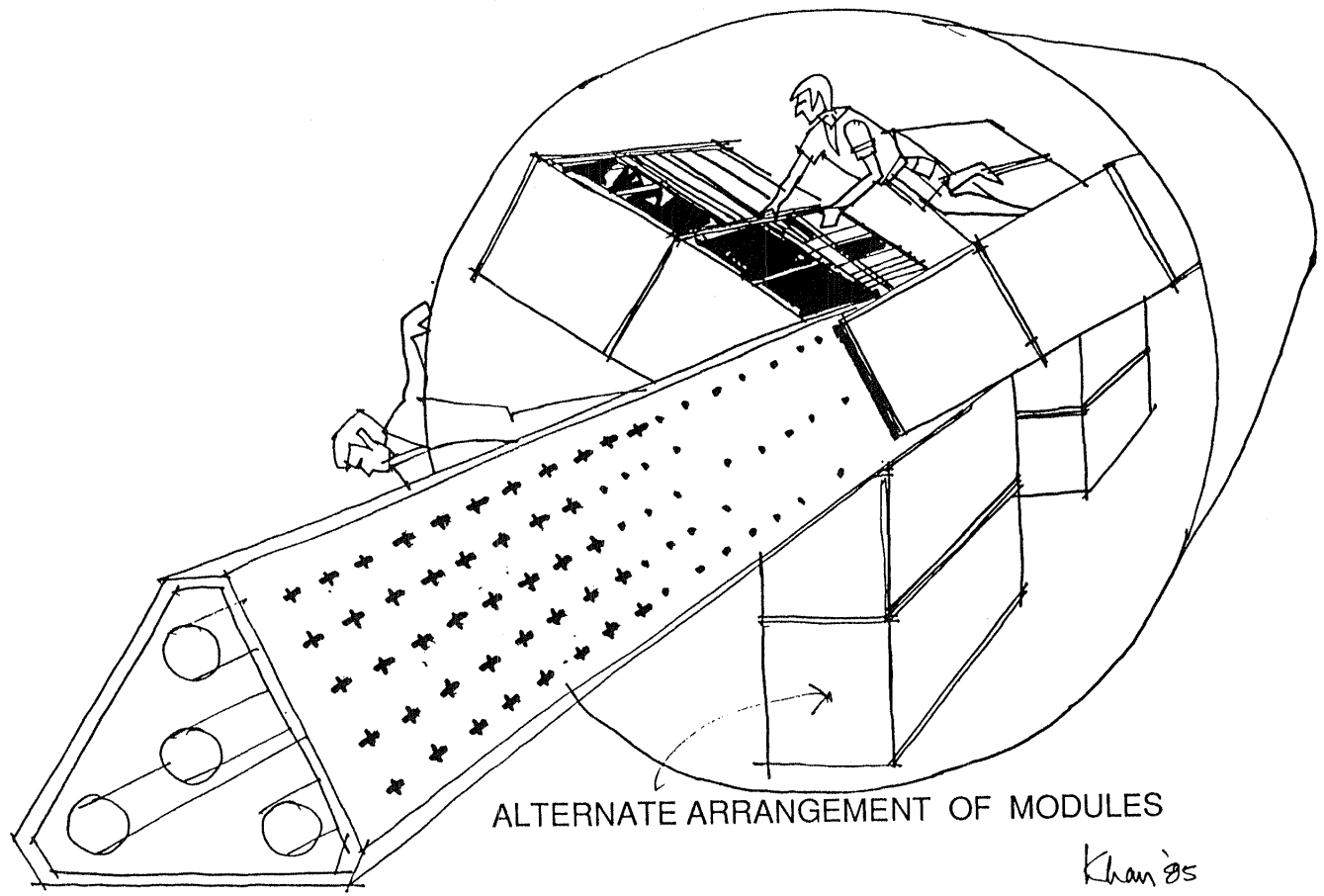
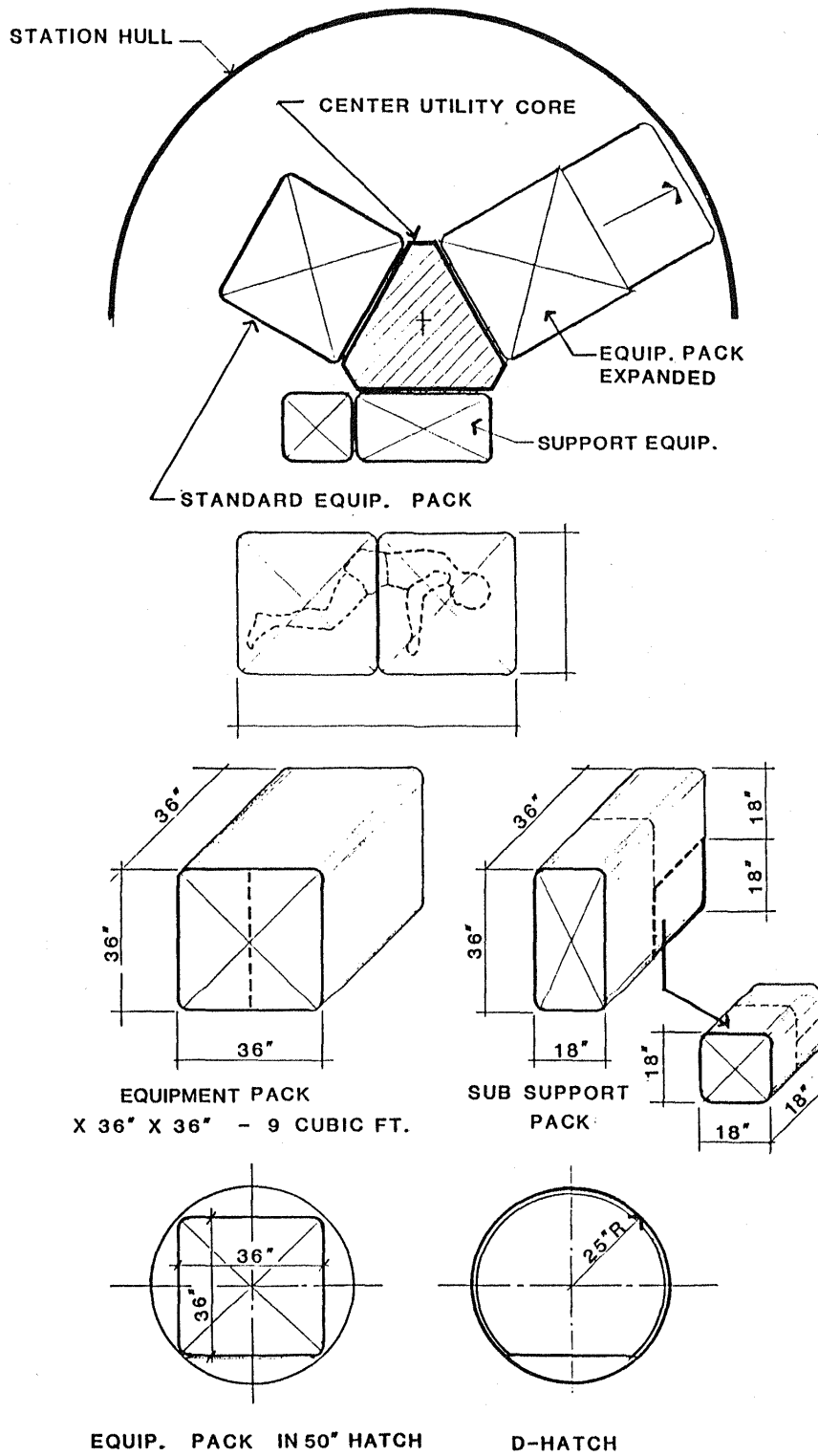

Figure 41 On Center Triangular Beam - Long Submodule System



THE EQUIP. PACKING SYSTEM (EPS) IS BASED ON A 9" CUBE .
 PACKAGES UP TO 36" CAN BE ASSEMBLED & PASS THROUGH
 A 50" D-HATCH EXPANDED PACKAGES CAN BE 5.5' IN LENGTH

Figure 42 Interior Assumptions

This case initially assumed single 3' x 3' modules plugging into the beam. In high equipment density volumes this may not provide the packing densities required. Figure 43 attempts to increase the packing density of the Triangular Beam configuration by adding a second module to plug into the beam in a half utility footprint design. The original idea of a second module was suggested by the NASA Technical Monitor, Marc Cohen, NASA-Ames Research Center. Applications along this direction of utilization are shown in Figure 44.

TRIANGULAR BEAM OFF CENTER

The Triangular Beam in an offset from centerline location which has some advantages and disadvantages over the "on center" solution. Figures 45, 46 and 47 depict the "off center" location.

SQUARE BEAM ON CENTER

The Square cross-section beam may have some advantages and is still under study. Figure 48 depicts an artist rendering of the square beam configuration. Figures 49 through 51 show several square configurations.

HEXAGONAL BEAM - SMALL

A Hexagonal Beam configuration is also possible and shown in rendering form in Figure 52. Figure 53 also depicts this shape. In radial type beam configurations it is important to allow room for the selective removal and replacement of submodules without moving other submodules. This may call for a larger section.

HEXAGONAL BEAM - LARGE

A Hexagonal Beam configuration with the ability to transport and pass submodules through the core beam is under study. Figure 54 shows the general idea. It permits the interior equipment shapes based on a 3 foot criteria to pass to the center and be transported longitudinally.

H BEAM - CENTER

The "H" shaped configuration has some advantages and is shown in Figure 55. The "H" Beam is combined with a "T" shaped utility duct to form an interesting volume with potential.

HEXAGONAL BEAM - MEDIUM

A Hexagonal Beam - Medium configuration splits the difference between the other two hexagonal beam configurations. It permits the ability to transport and pass submodules through the core beam and exterior to the beam, see Figure 56. It permits the interior equipment shapes based on a 3 foot criteria to pass to the center and be transported longitudinally. The shapes are under study including the dense pack triangular shown in Figure 56 and the "Expanded Triangular" as shown in Figure 57.

LOADED TRIANGULAR BEAM - CENTER OF THE MODULE

Photograph-6 depicts a partially loaded Triangular Beam. The 3' x 3' x 7' submodules are attached to a standard utility footprint located every three feet along the triangular beam. The utilities would have a flexible connection on both the beam end and the submodule to permit the attachment process to proceed with about two feet of working volume between the two units. The submodule unit is then rigidly attached to the beam. If the submodules are launched in this location, then additional shipping bracing is required.

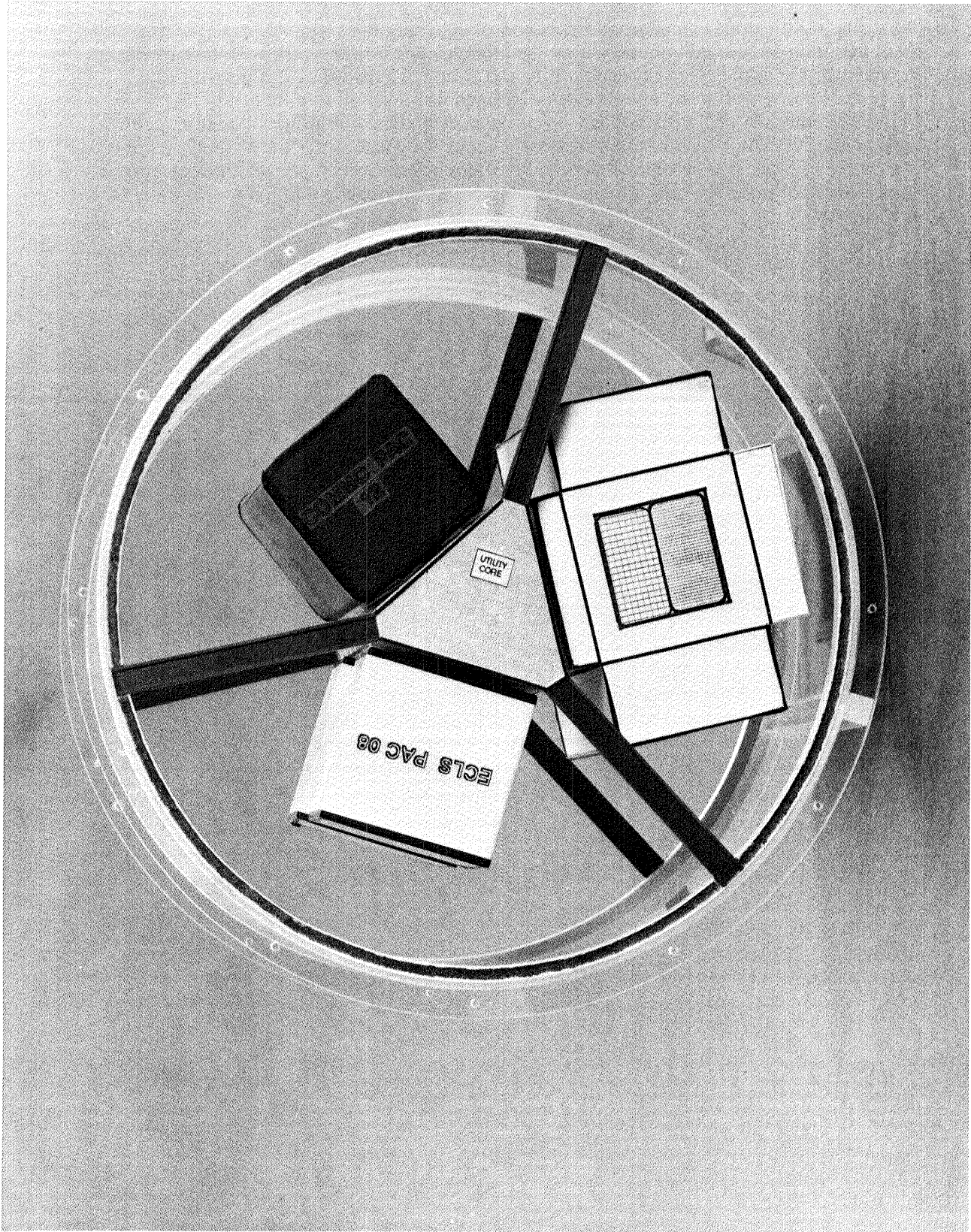

Photograph-6 Triangular Beam Loaded with Submodules

LONGITUDINALLY LOADED TRIANGULAR BEAM

Photograph-7 illustrates an alternative method of attaching the submodules to the triangular beam to obtain additional volume within the module. The utilities with such a beam design include a single loop design for each utility and assumes a racetrack design with four modules. Beams with more complicated dispersed utilities will require utility loops within each module and will increase the complexity and cost of utilities and interfaces exponentially. The ECLSS units and storage tanks for waste water for example are located around the utility loops in appropriate modules and transfer processed water to clean water lines. The distributed ECLSS units provide increased survivability in the event of the loss of a module.

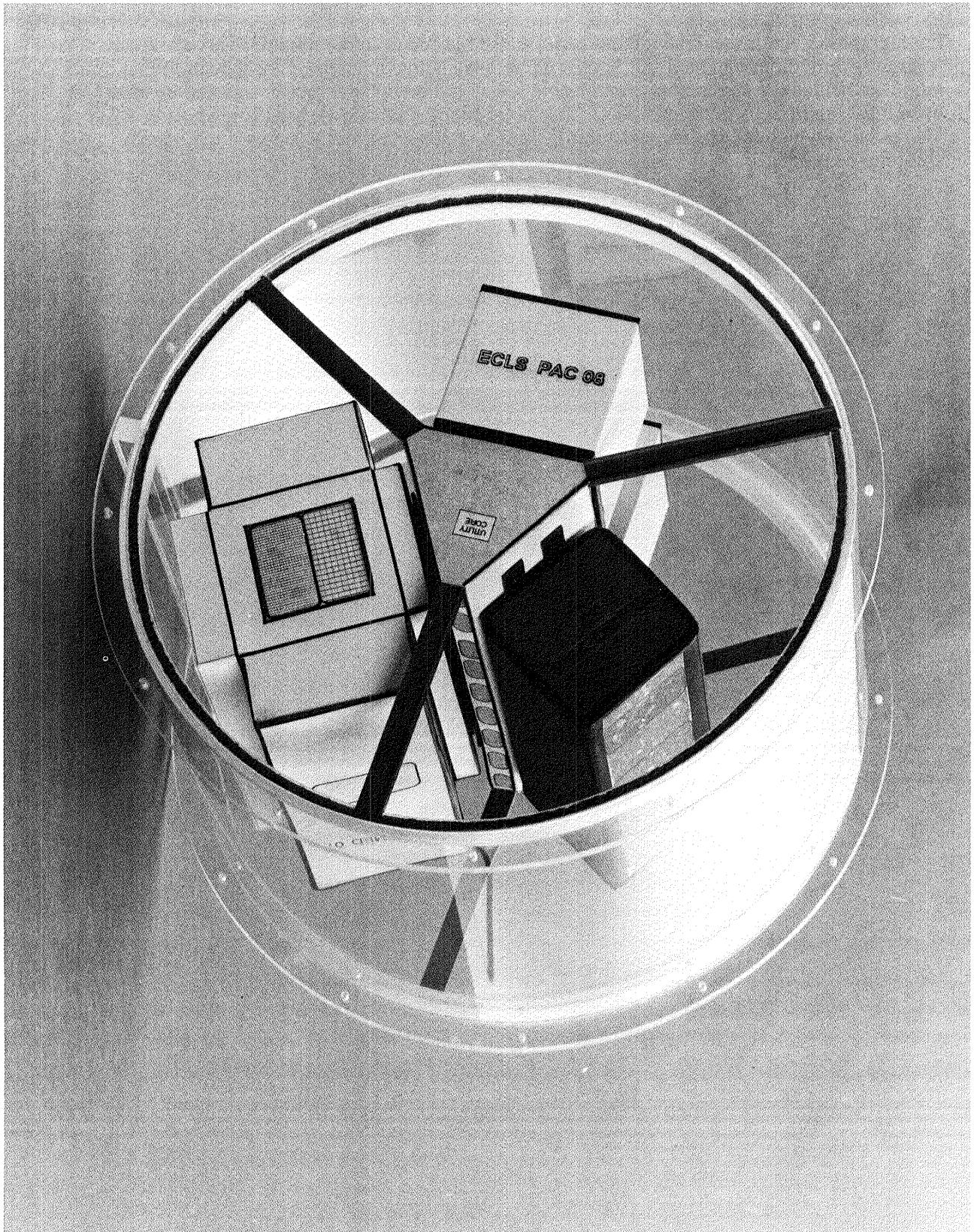

Photograph-7 Triangular Beam Loaded Longitudinally With Submodules

TRIANGULAR BEAM LOCATED OFF CENTER

Photograph-8 depicts the Triangular Beam located off center in the module. The advantage is larger submodules can be used. Some submodules being considered for the common modules include the space telescope console which is somewhat larger in size and appears to be a pacing item for interior design. The large submodule shown is an Engineering Workstation which is expanded on orbit by pulling out several of the sides of the launch shipping container.

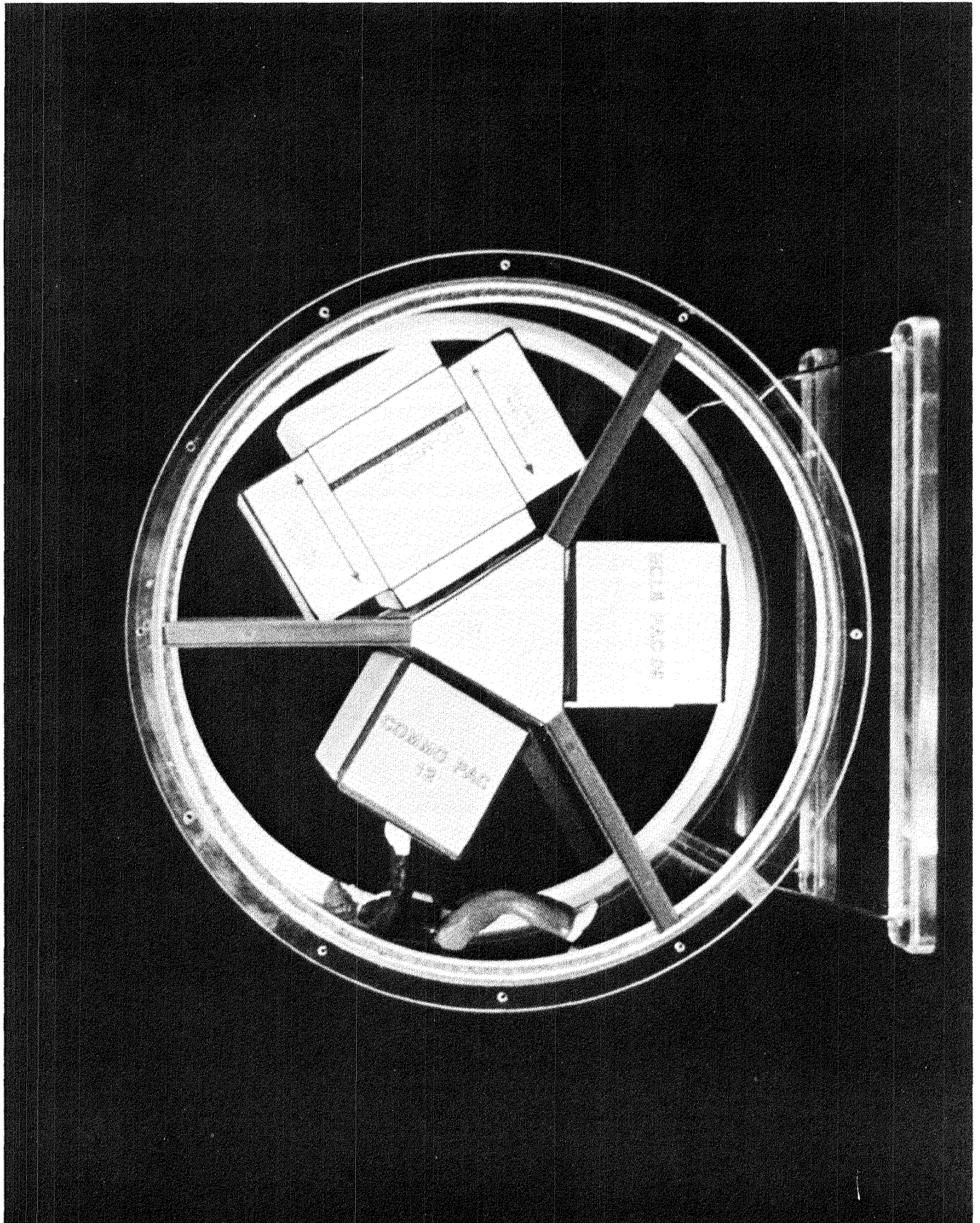

Photograph-8 Triangular Beam-Off Center in the Module

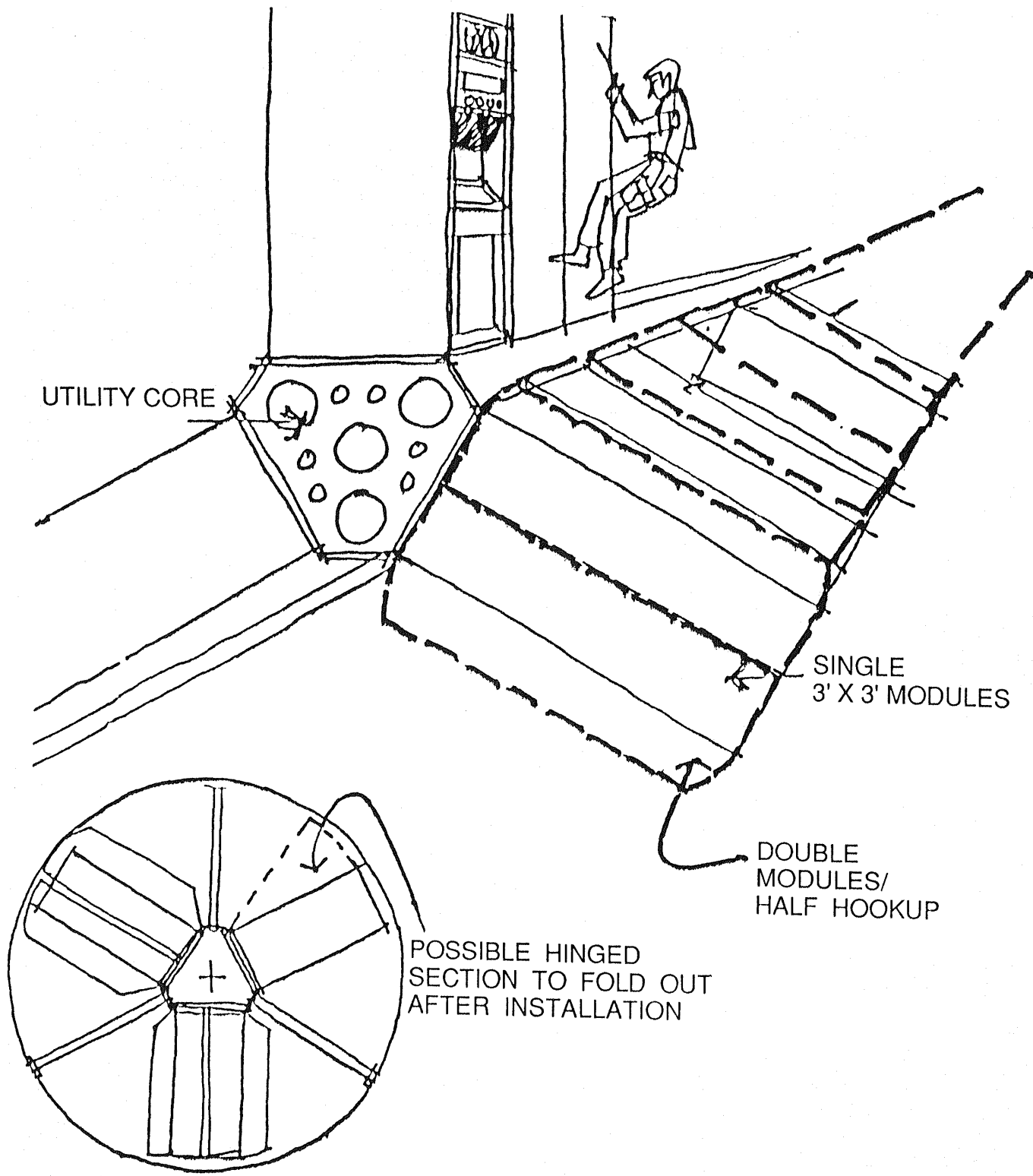

Figure 43 Double Submodule/Half Hook Up Concept

DOUBLE SUBMODULES

SIZE VARIES FOR THE SEPARATE 3' VOLUMES

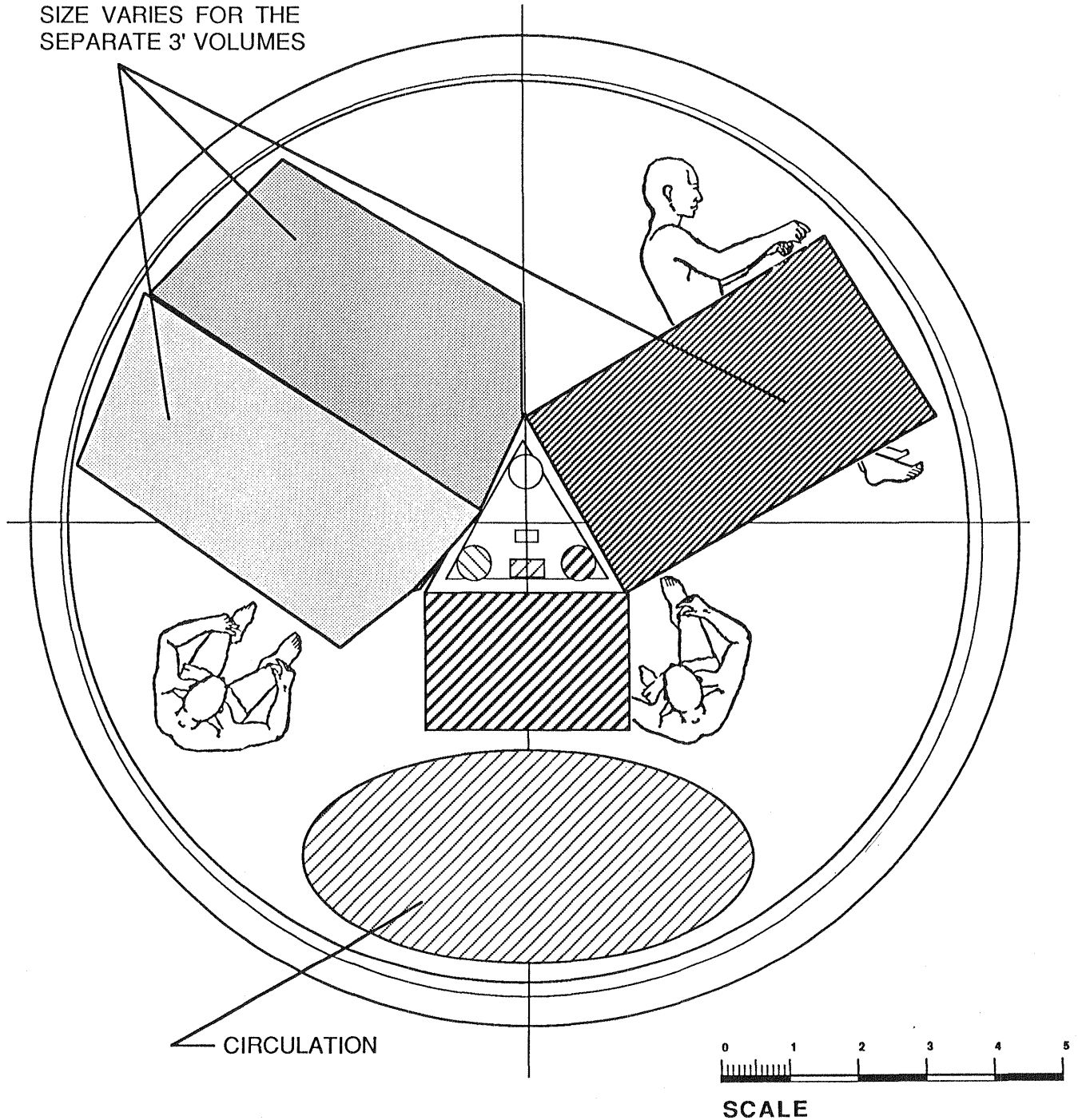

Figure 44 High Density Pack

TRIANGULAR OFF CENTER BEAM

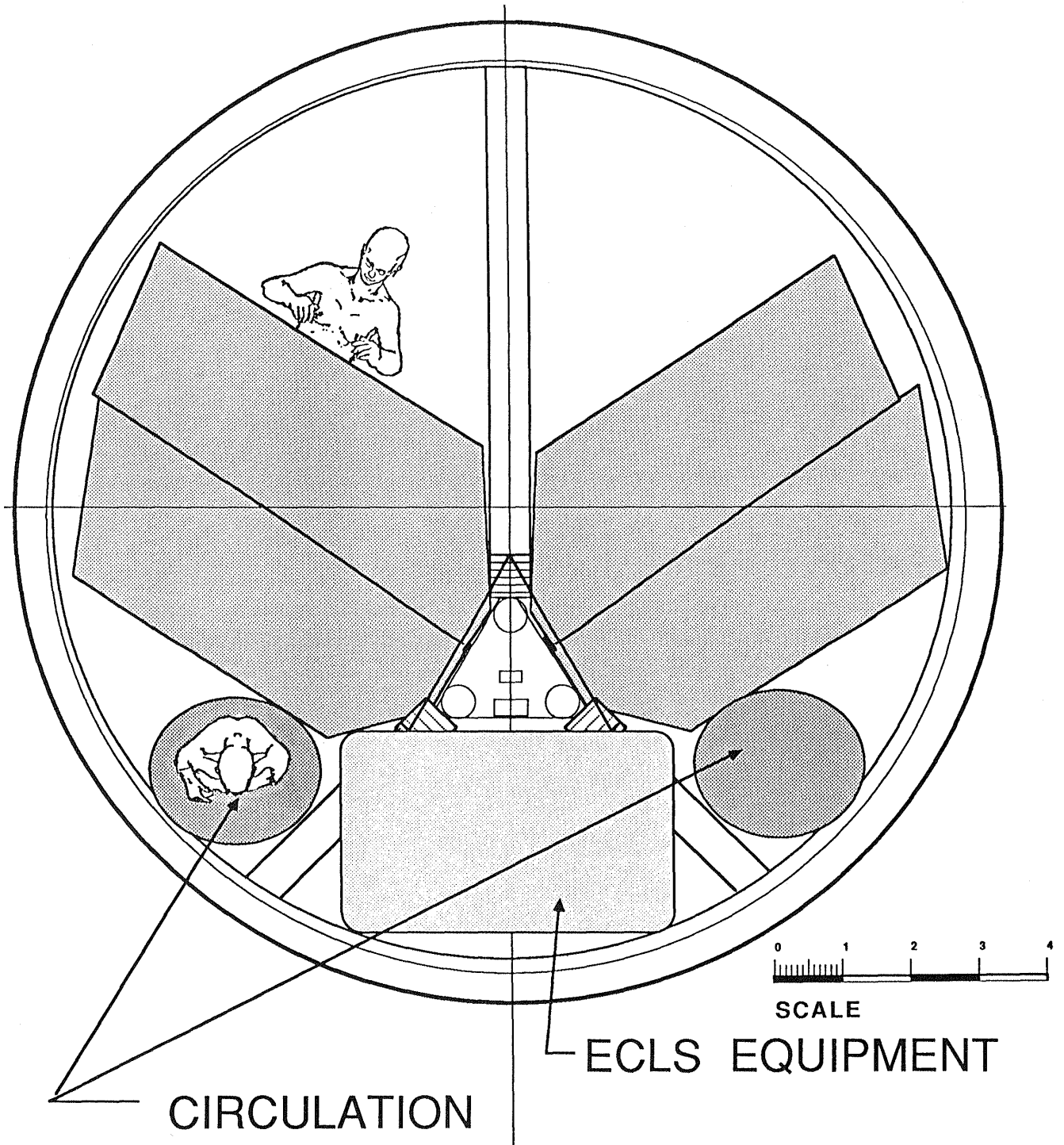
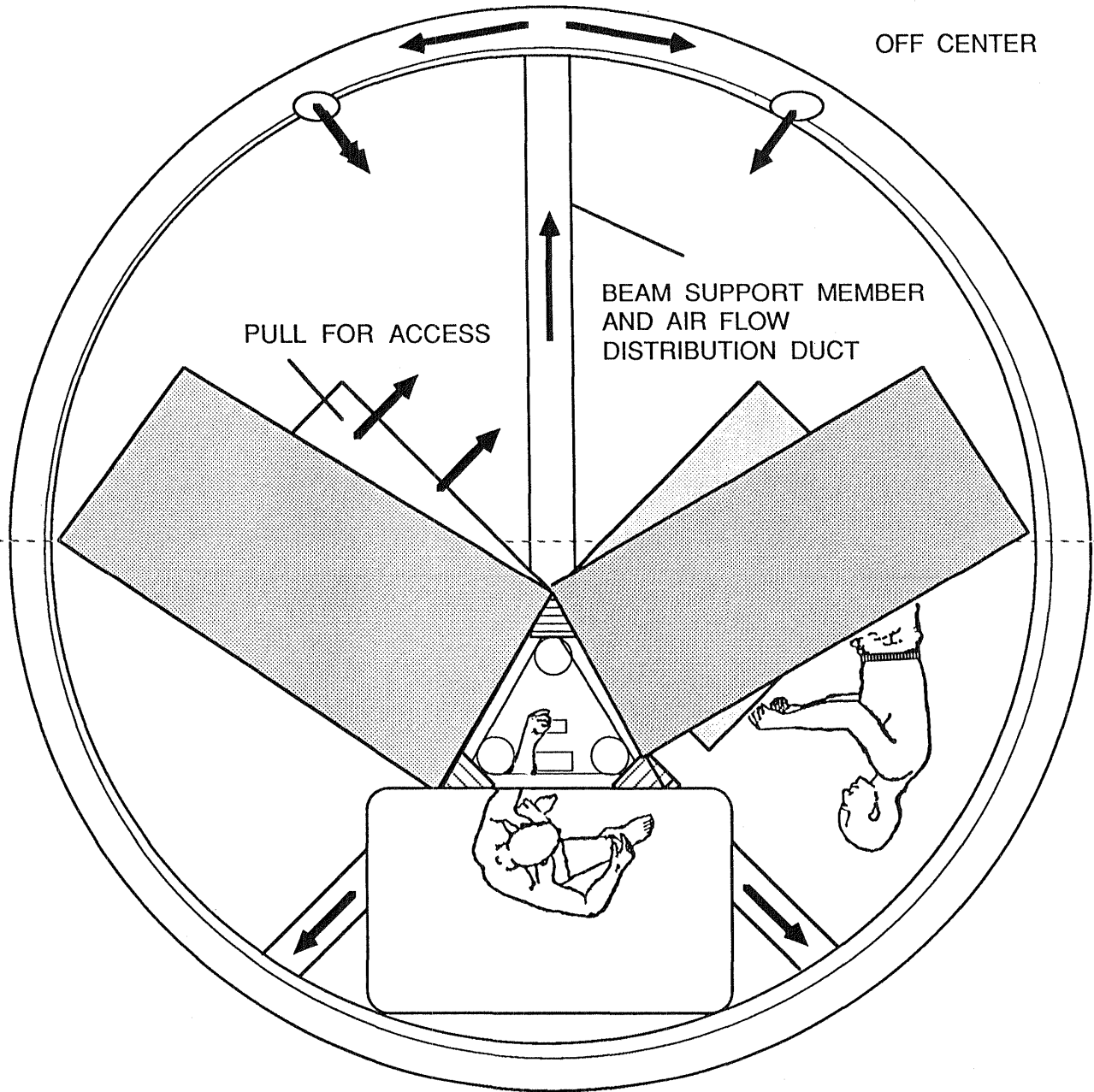

Figure 45 Triangular Off Center Beam - High Density

MODEL FABRICATION TRIANGULAR BEAM



SUPPORT BEAM IS CIRCULAR AND PROVIDES FASTENING LOCATION, AIR FLOW, LIGHTING AND MISC TO THE EXTERIOR SURFACE.

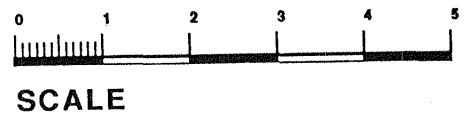
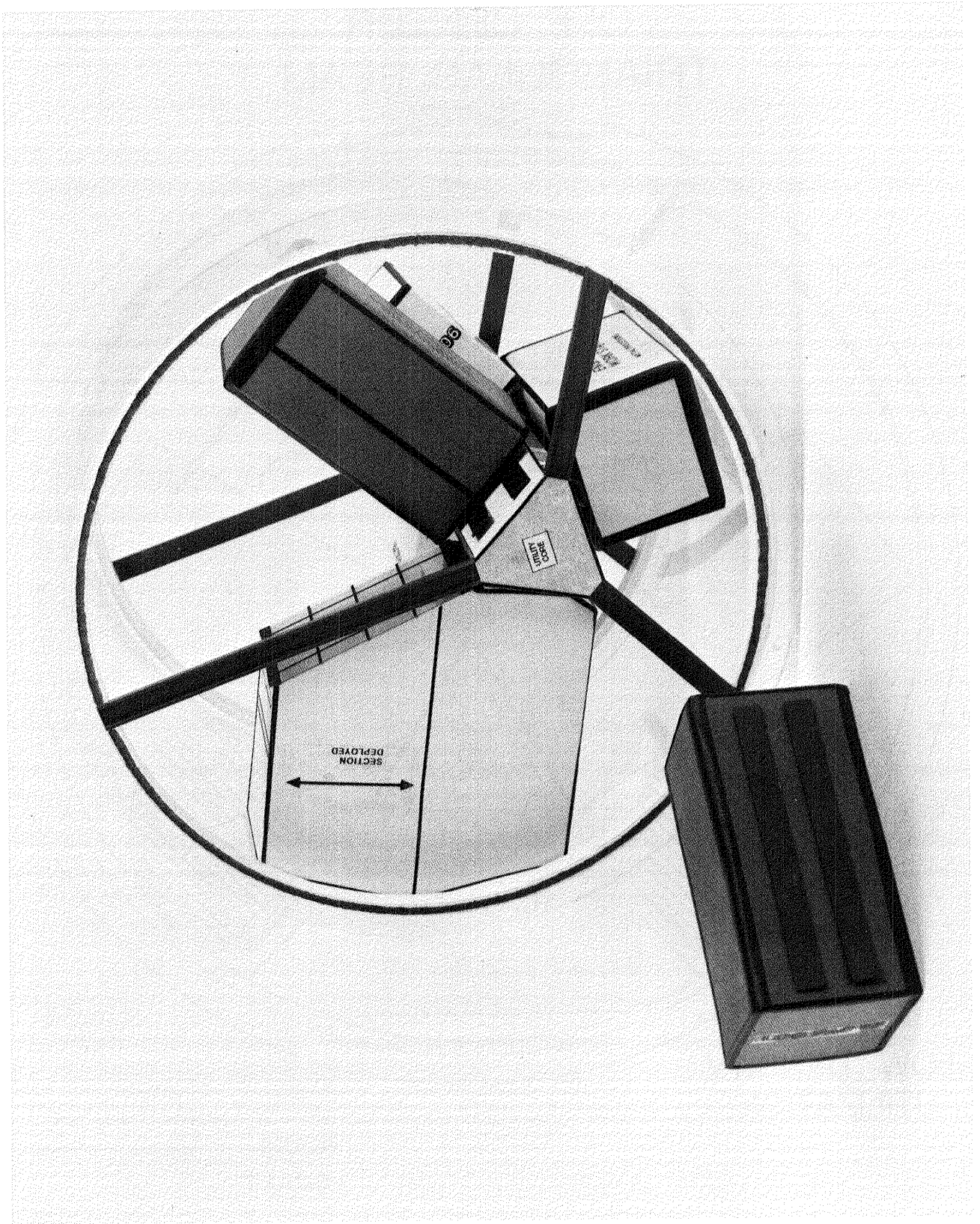

Figure 46 Maintenance and Changeout

TRIANGULAR BEAM - EXPANDED SUBMODULE

Photograph-9 illustrates the model method of attaching the submodules to the central beam using strips of magnetic tape. The Engineering Workstation Design shown in this photograph uses an expanded side wall technique to create a large internal private volume for the workstation.



Photograph-9 Triangular Beam with Expanded Submodule

OFF CENTER TRIANGULAR BEAM

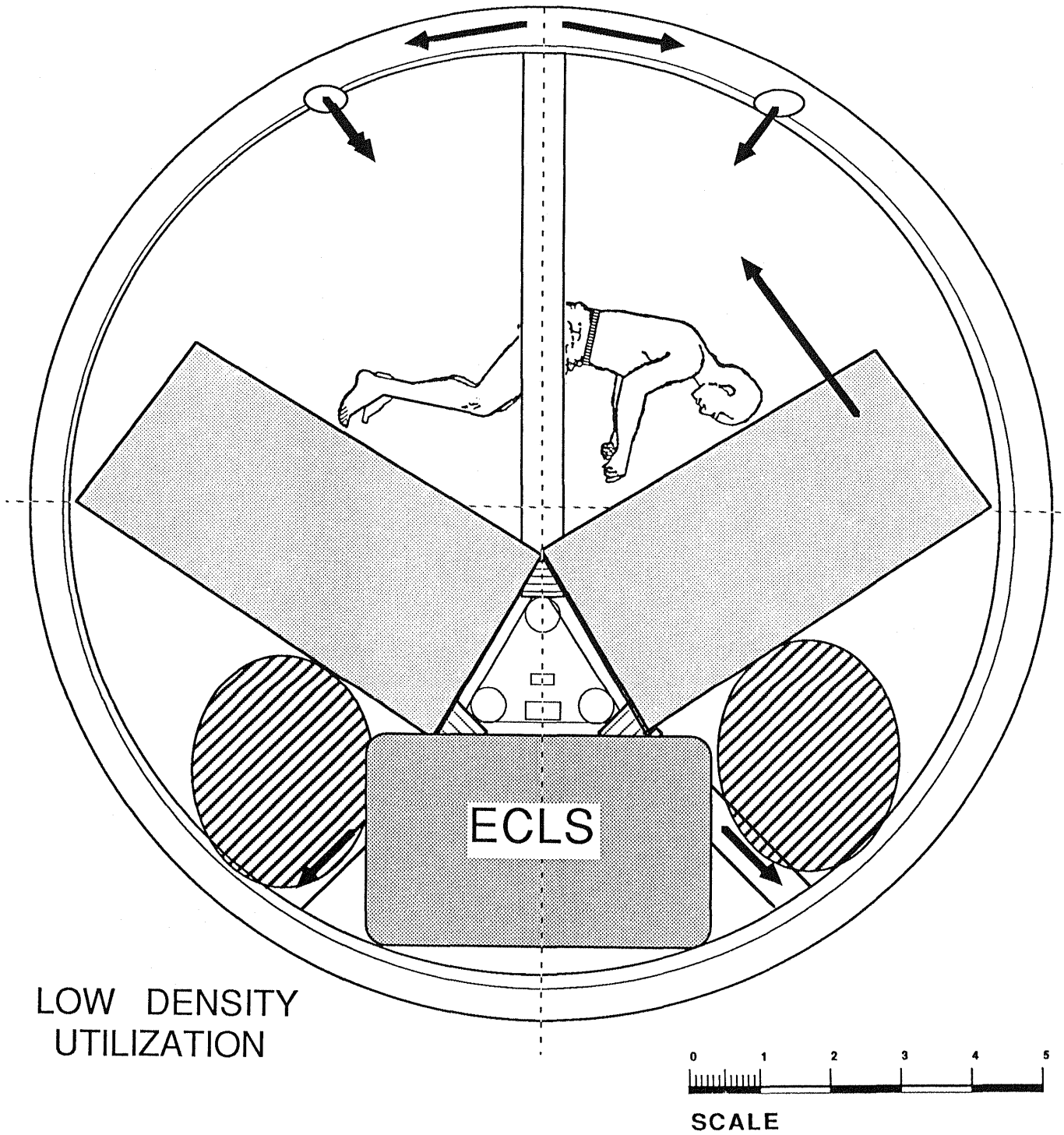

Figure 47 Triangular - Off Center

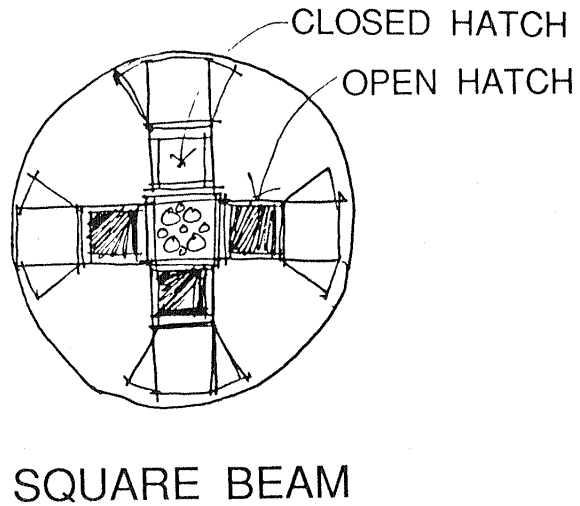
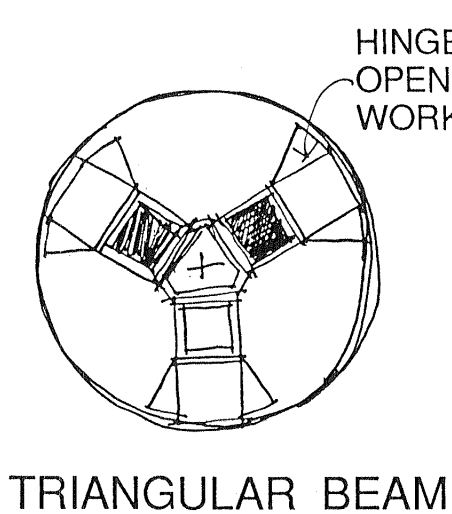
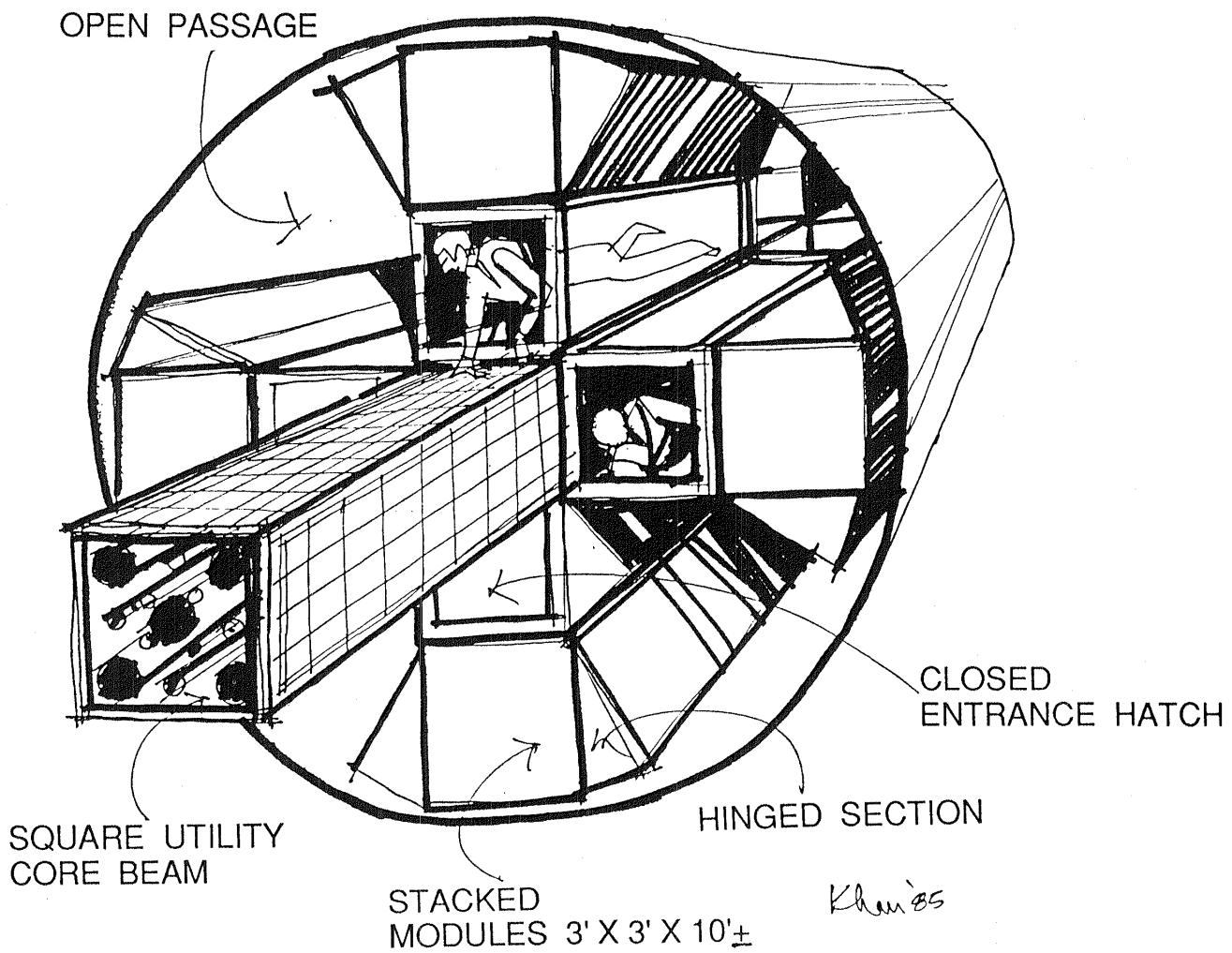
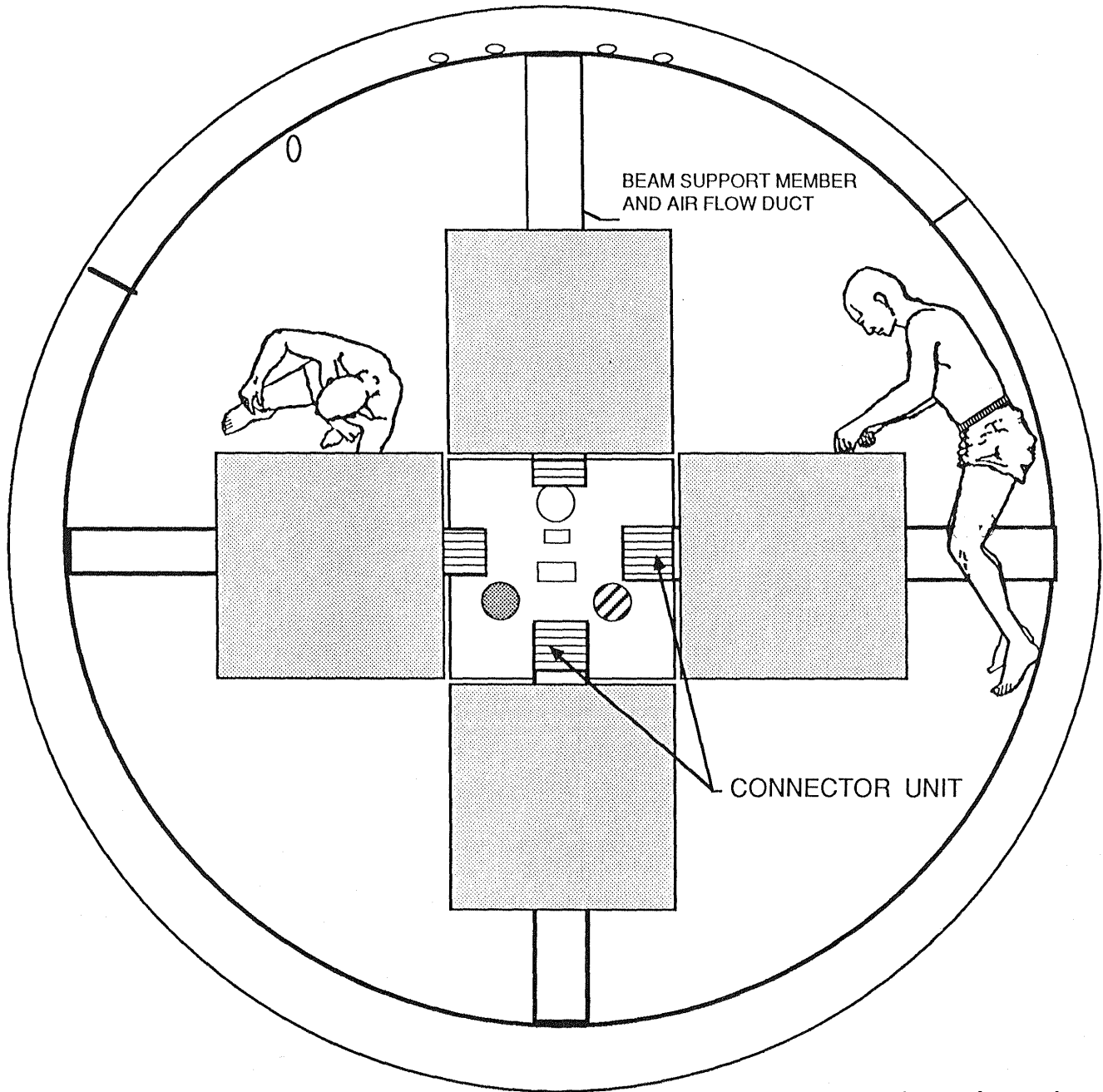

Figure 48 Square Beam Configuration (1 of 4)

SQUARE BEAM ON CENTER



SCALE

Figure 49 Square Beam Configuration (2 of 4)

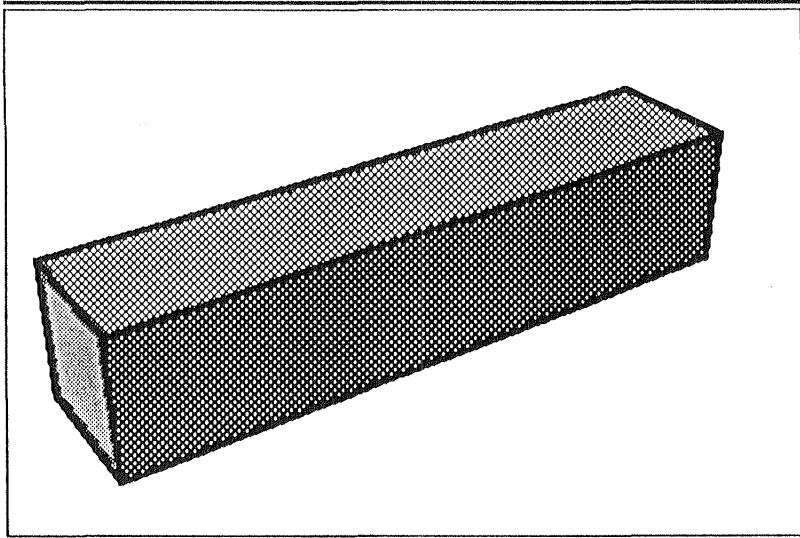

SQUARE BEAM

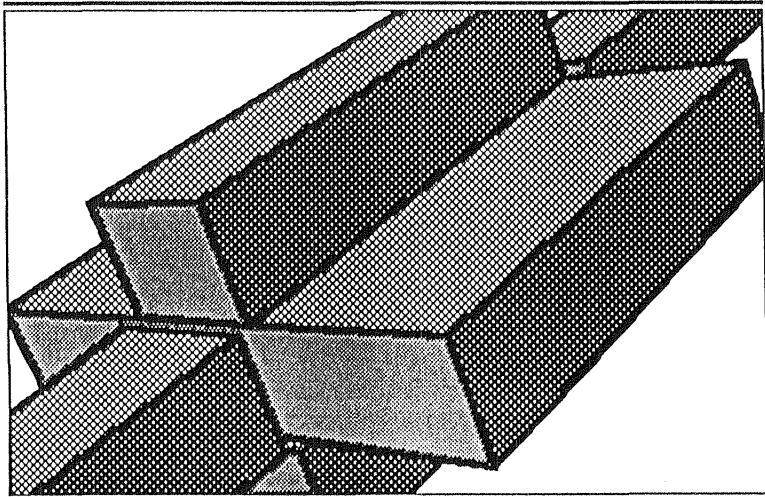

**SQUARE BEAM
WITH LONGITUDINAL
SUBMODULES**

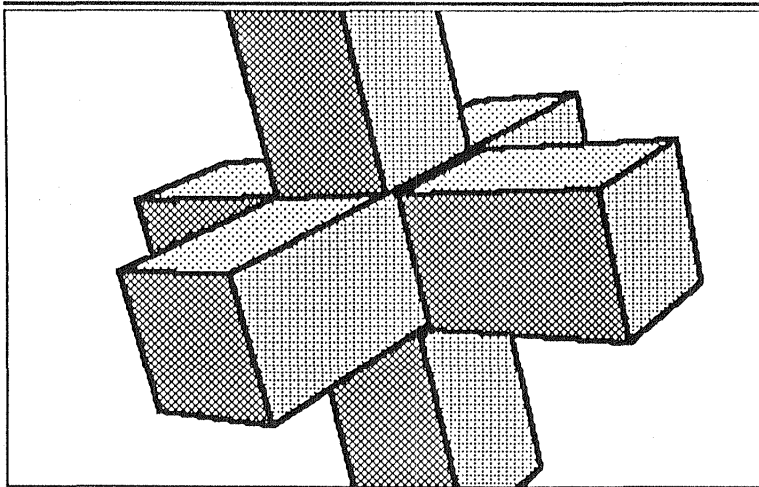

**SQUARE BEAM
WITH PERPENDICULAR
SUBMODULES**

Figure 50 Square Beam Configuration (3 of 4)

MODEL MATERIALS SQUARE BEAM OPTION A

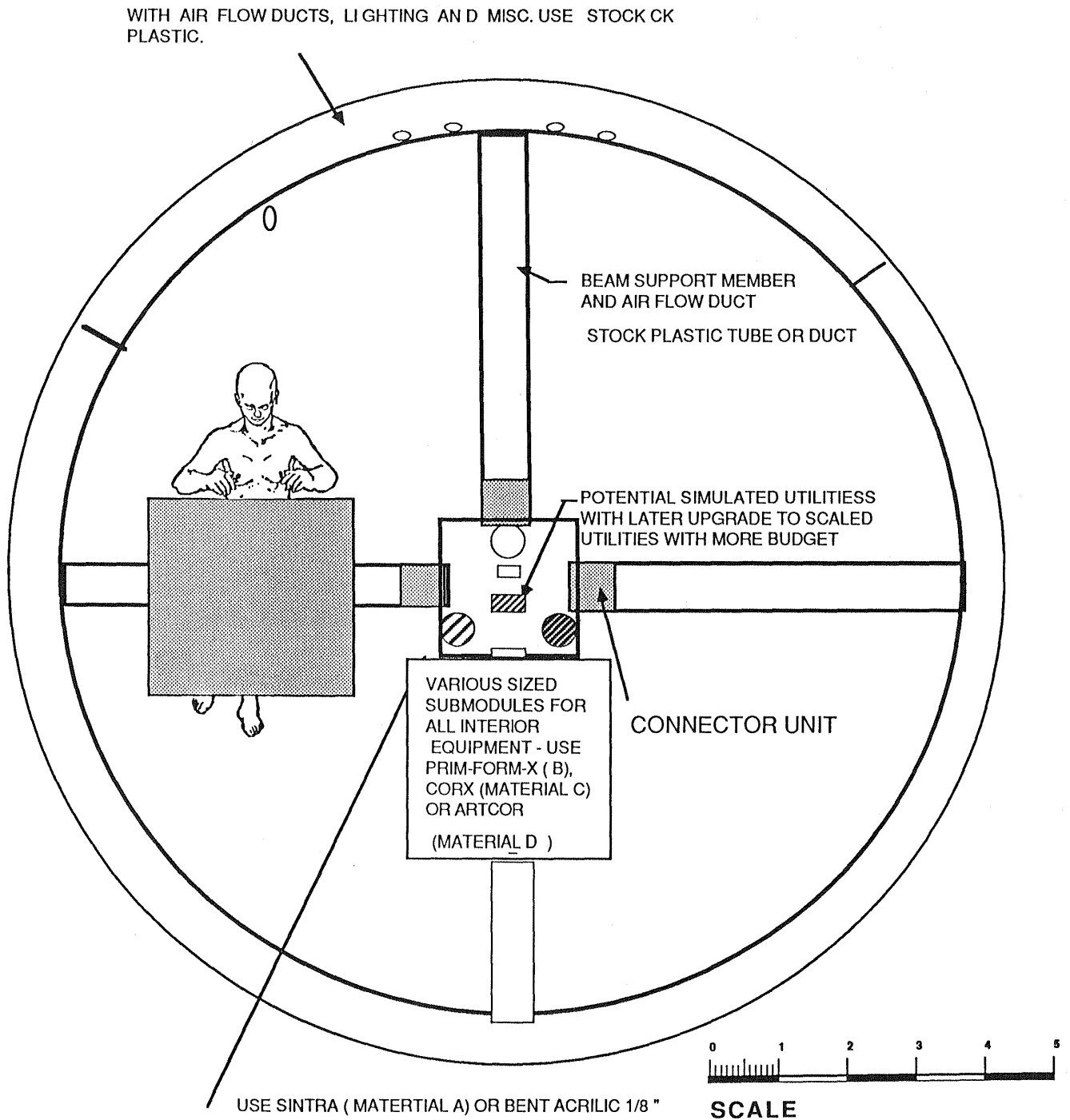
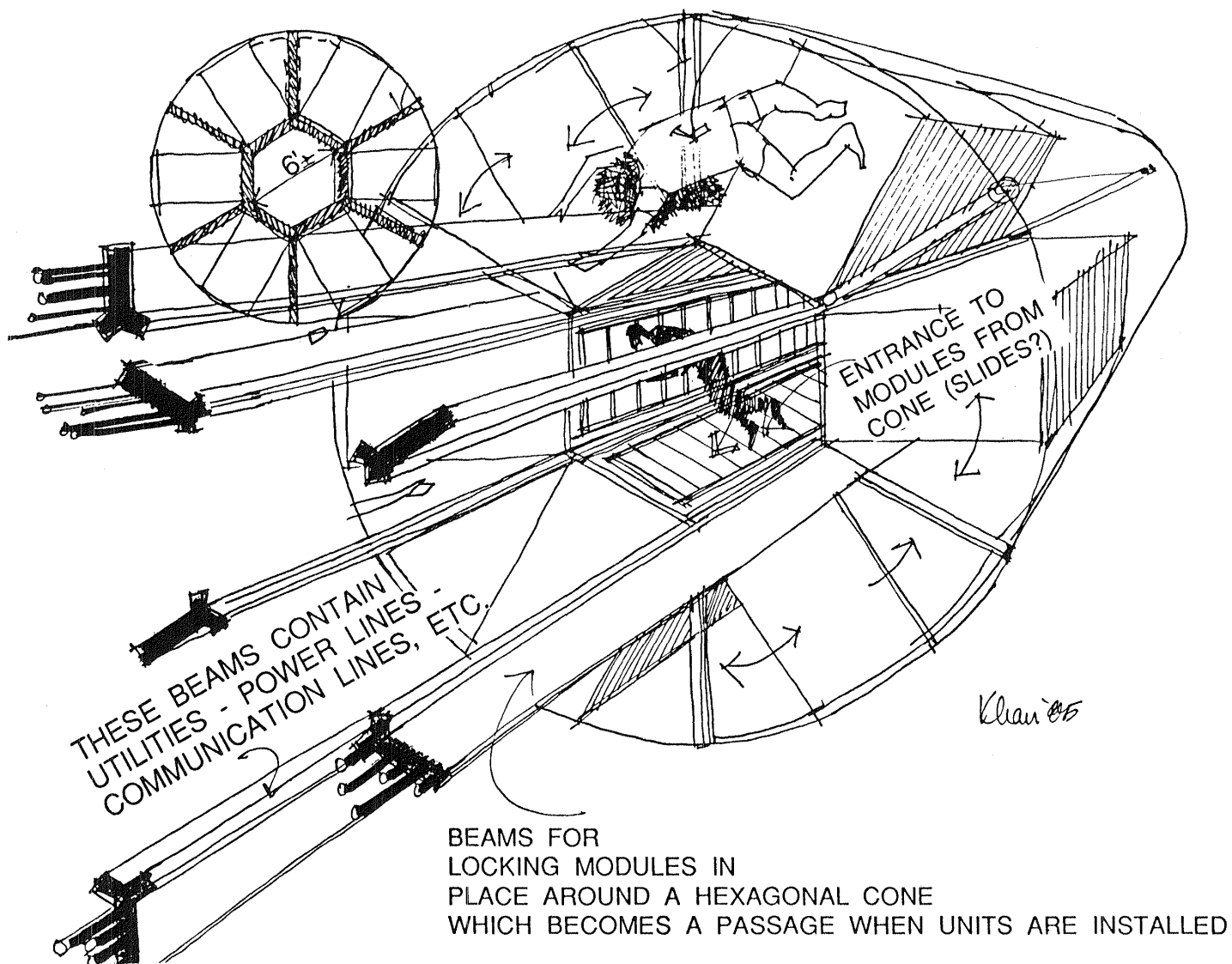
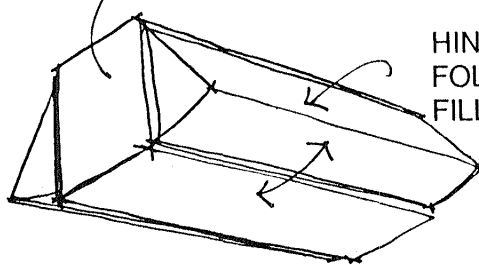

Figure 51 Square Beam Configuration (4 of 4)



3' X 4' X 9' MODULES
FIT THRU 50" HATCH



HINGED SECTION
FOLDS OUT TO
FILL COMPARTMENT

Figure 52 Hex Beam - Small Diameter

SQUARE BEAM ON CENTER

Photograph-10 illustrates the Square Beam on the Center in the Module and fits well with an off center hatch at the ends of the modules. The photograph shows an expanded square submodule attached to each of the four sides of the square central beam.

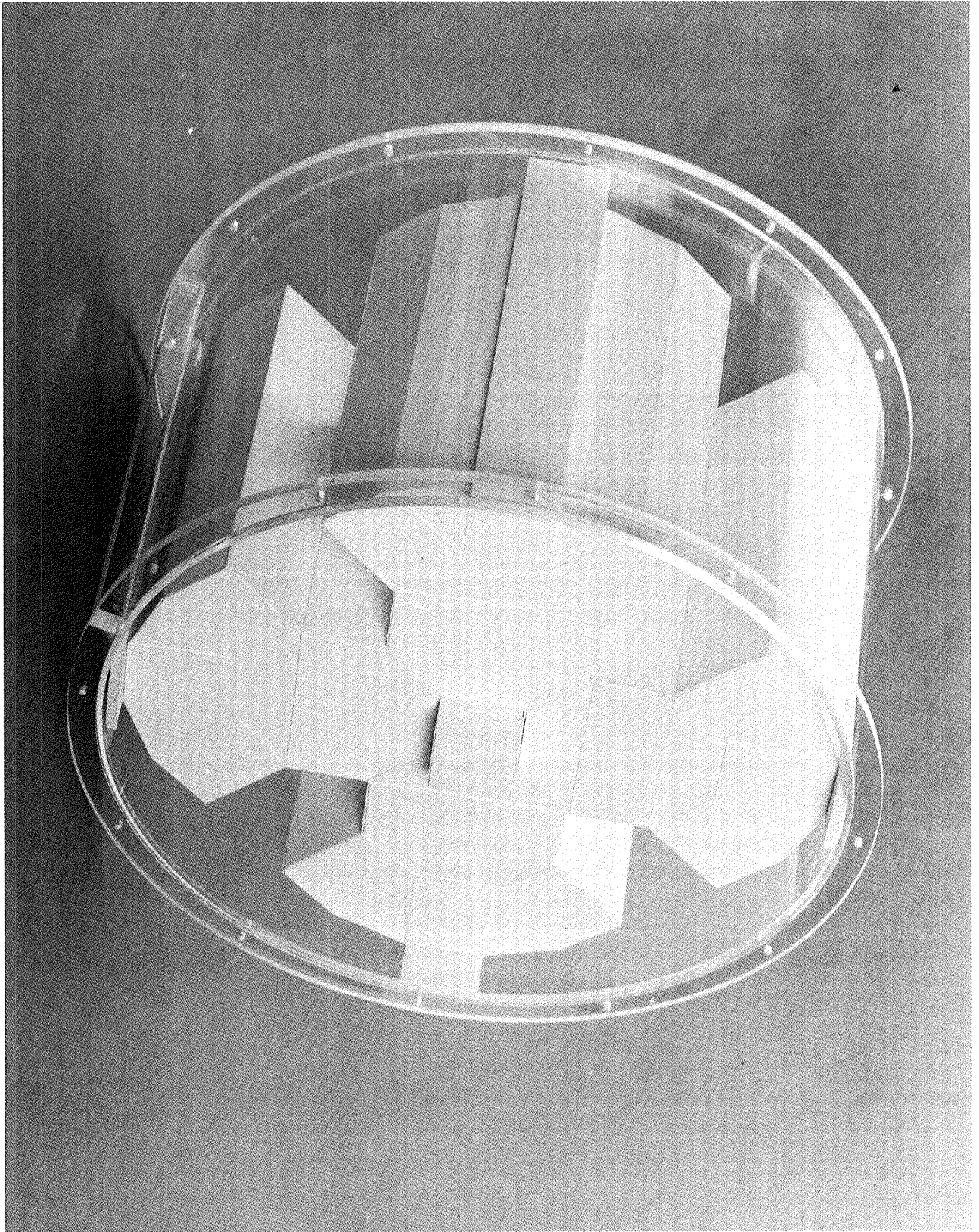

Photograph-10 Square Beam-On the Center in the Module

SQUARE BEAM ON CENTER - CLOSE UP

Photograph-11 illustrates the Square Beam close up view to show the ability of the 49.4% percentile male to move within the volume between the submodules. The photograph shows expanded square submodules attached to each of the four sides of the square central beam. Each of the submodules can be used and interfaced from the outside or a volume can be created inside the submodule.

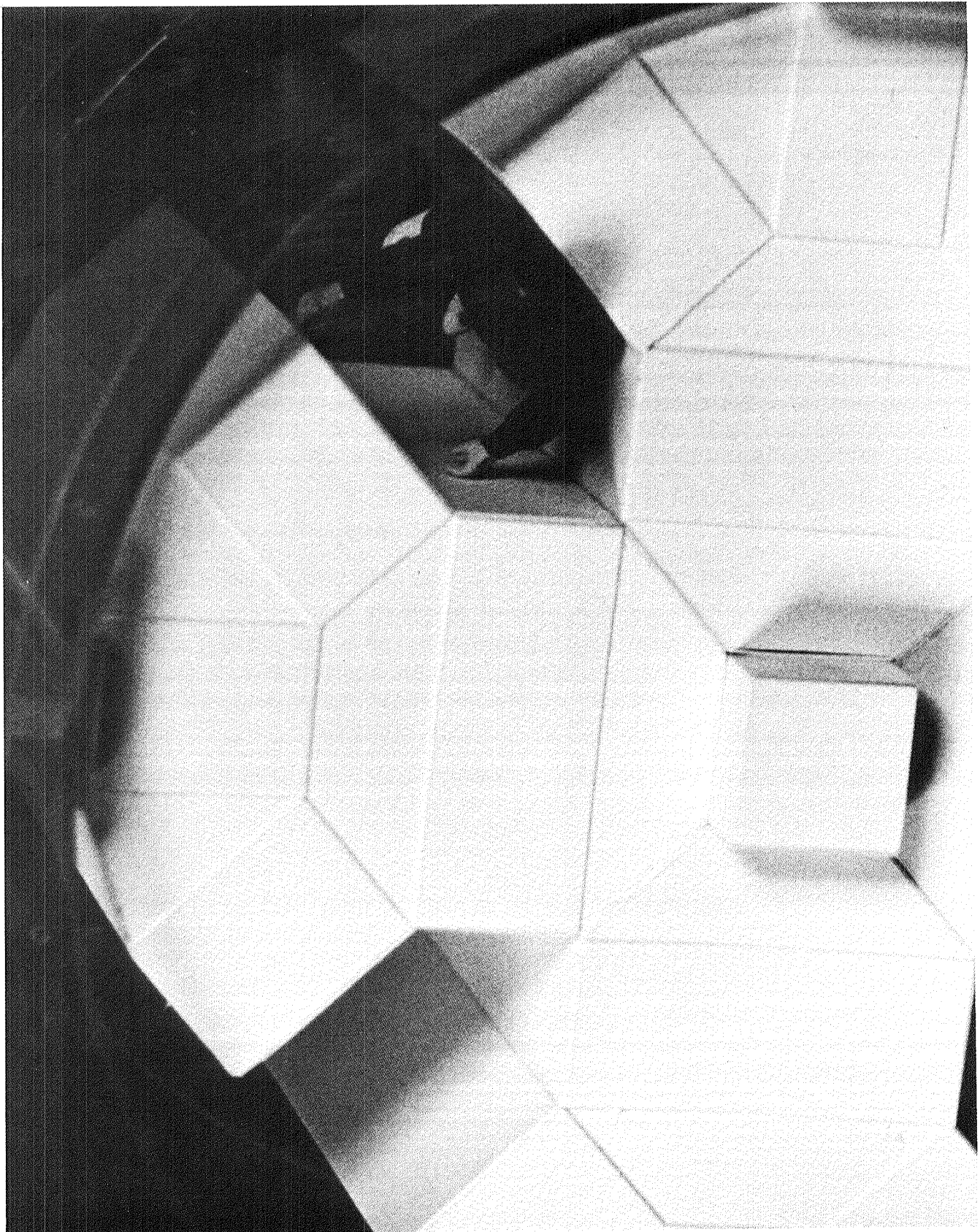

Photograph-11 Square Beam and Submodule Close Up

HEXAGONAL BEAM - SMALLER THAN 4 FEET

Photograph-12 depicts the first of three Hexagonal Beam Designs which are all located in the center of the module. This design permits a hexagonal shaped submodule to fit through the center support structure and be distributed throughout the module without moving other submodules. It also permits other raw material logistics submodules of the same shape to be attached and detached at will next to each of the future commercial processing submodules.

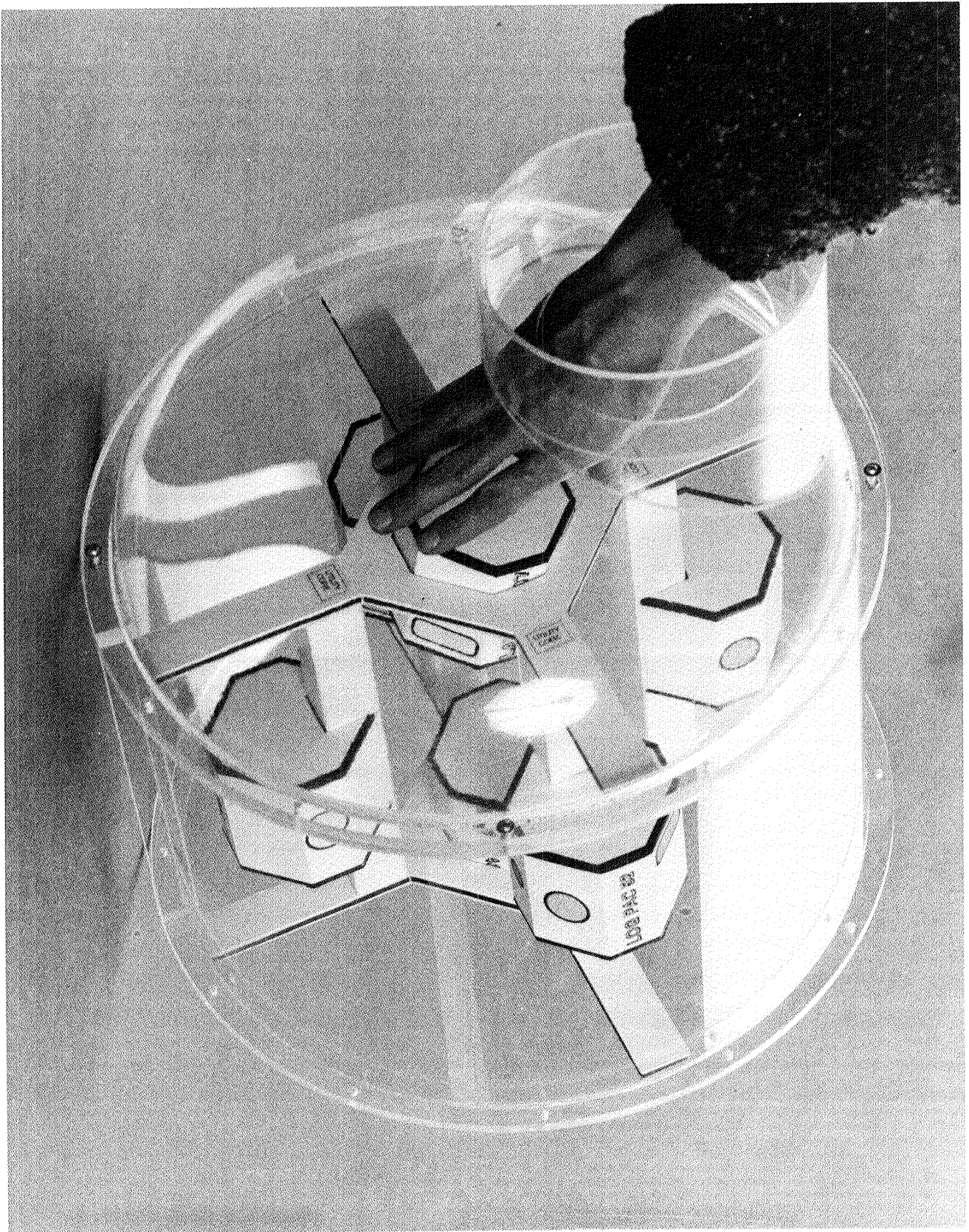

Photograph-12 Hexagonal Beam with Centerline Translation

HEXAGONAL BEAM - LOGISTICS RESUPPLY OF SUBMODULES

Photograph-13 depicts Hexagonal Beam Design which permits resupply of raw materials along the center of the module. This design permits a hexagonal shaped submodule to fit through the center support structure and be distributed throughout the module without moving other submodules. It permits raw material logistics submodules of the same shape to be attached and detached at will next to each of the future commercial processing submodules.

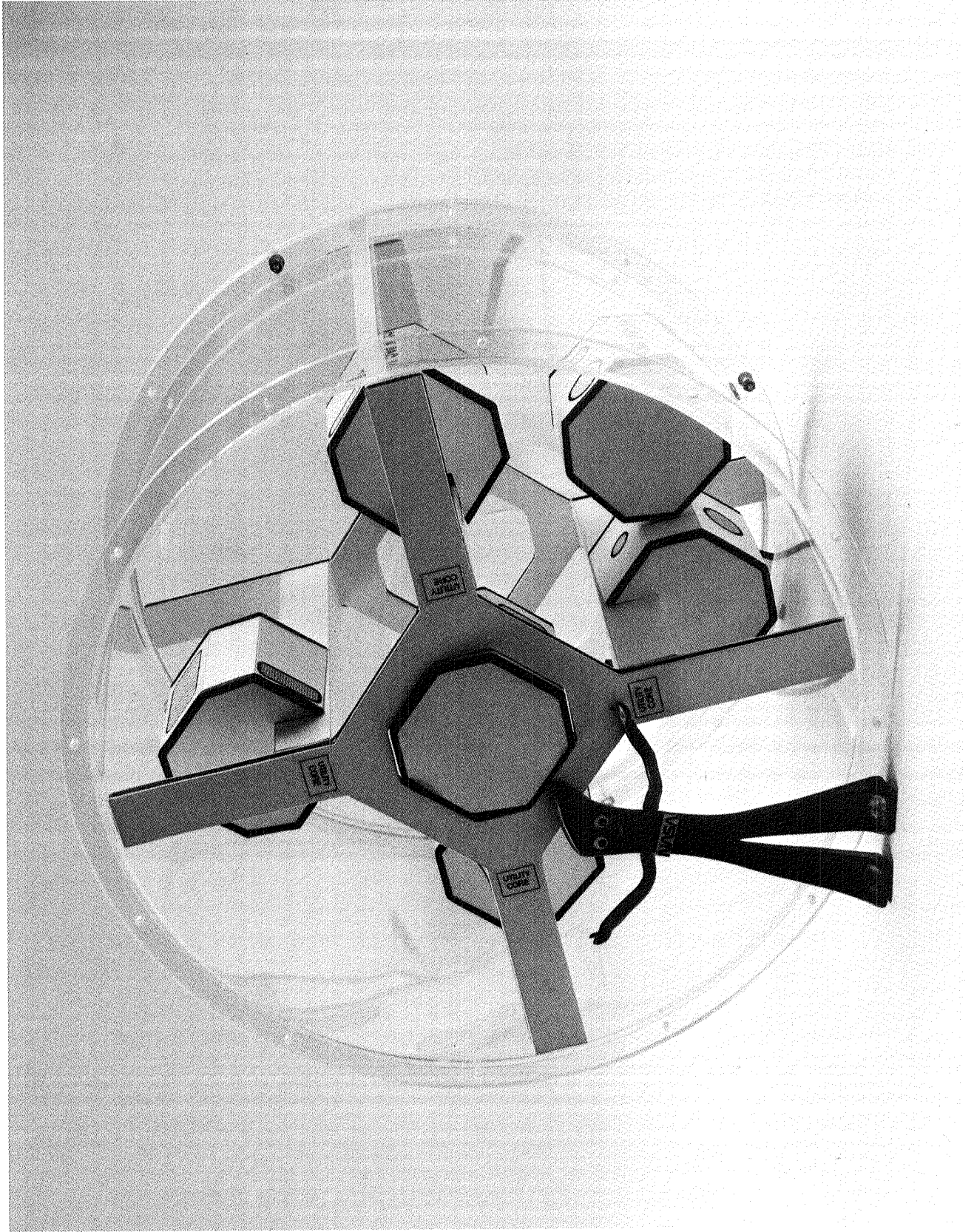

Photograph-13 Hexagonal Beam with Centerline Logistics

HEXAGONAL BEAM - THE HUMAN ELEMENT IN LOGISTICS RESUPPLY OF SUBMODULES

Photograph-14 depicts Hexagonal Beam Designs with the scaled human inside the module to move the submodules for resupply of raw materials along the center of the module. This design permits a hexagonal shaped submodule with human assistance to fit through the center support structure and be distributed throughout the module without moving other submodules. It permits sufficient volume for human intervention with the process submodules and raw material logistics submodules translation of the same shape to be attached and detached at will next to each of the future commercial processing submodules.

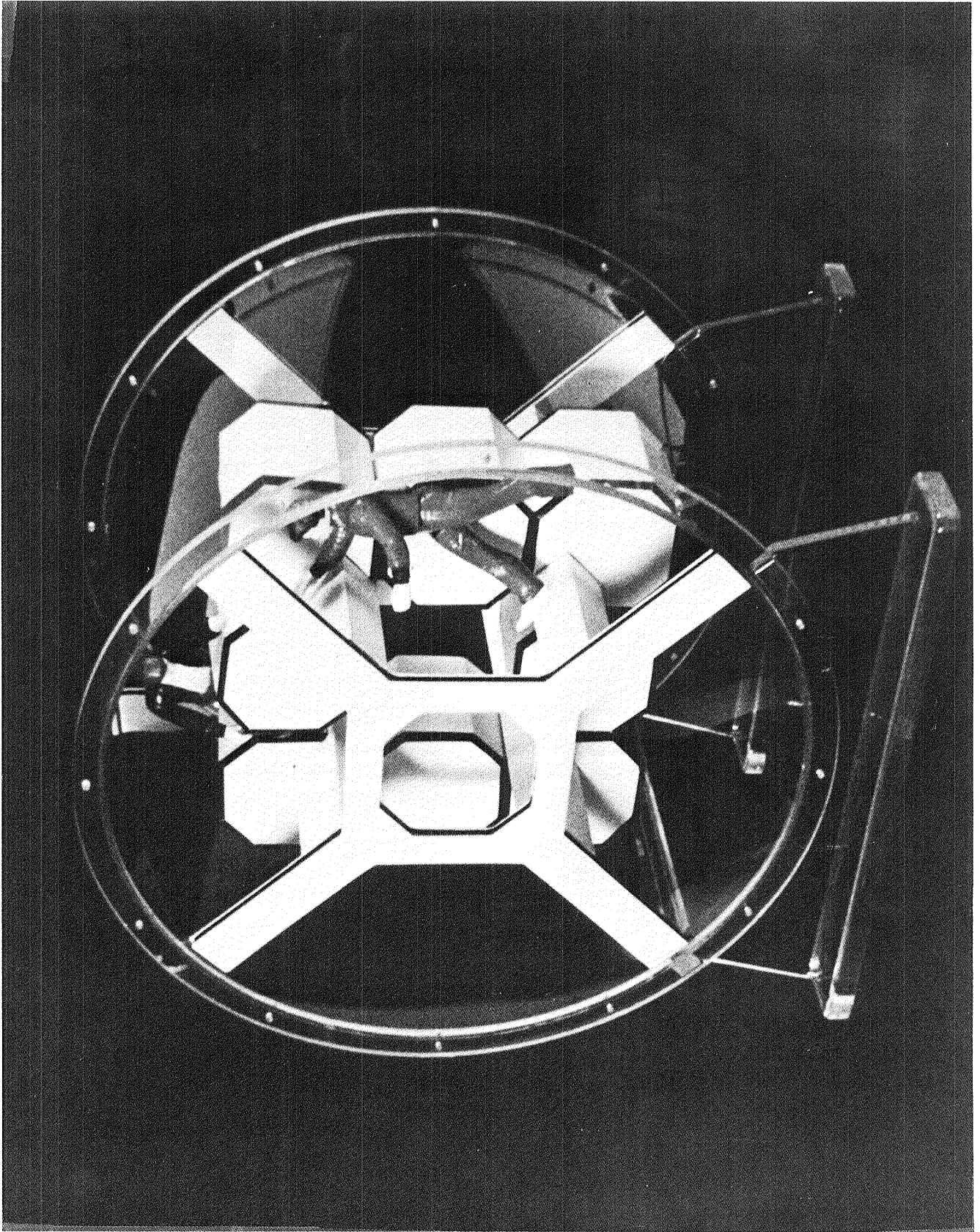

Photograph-14 Hexagonal Beam with Human Logistics Volume

HEXAGON BEAM

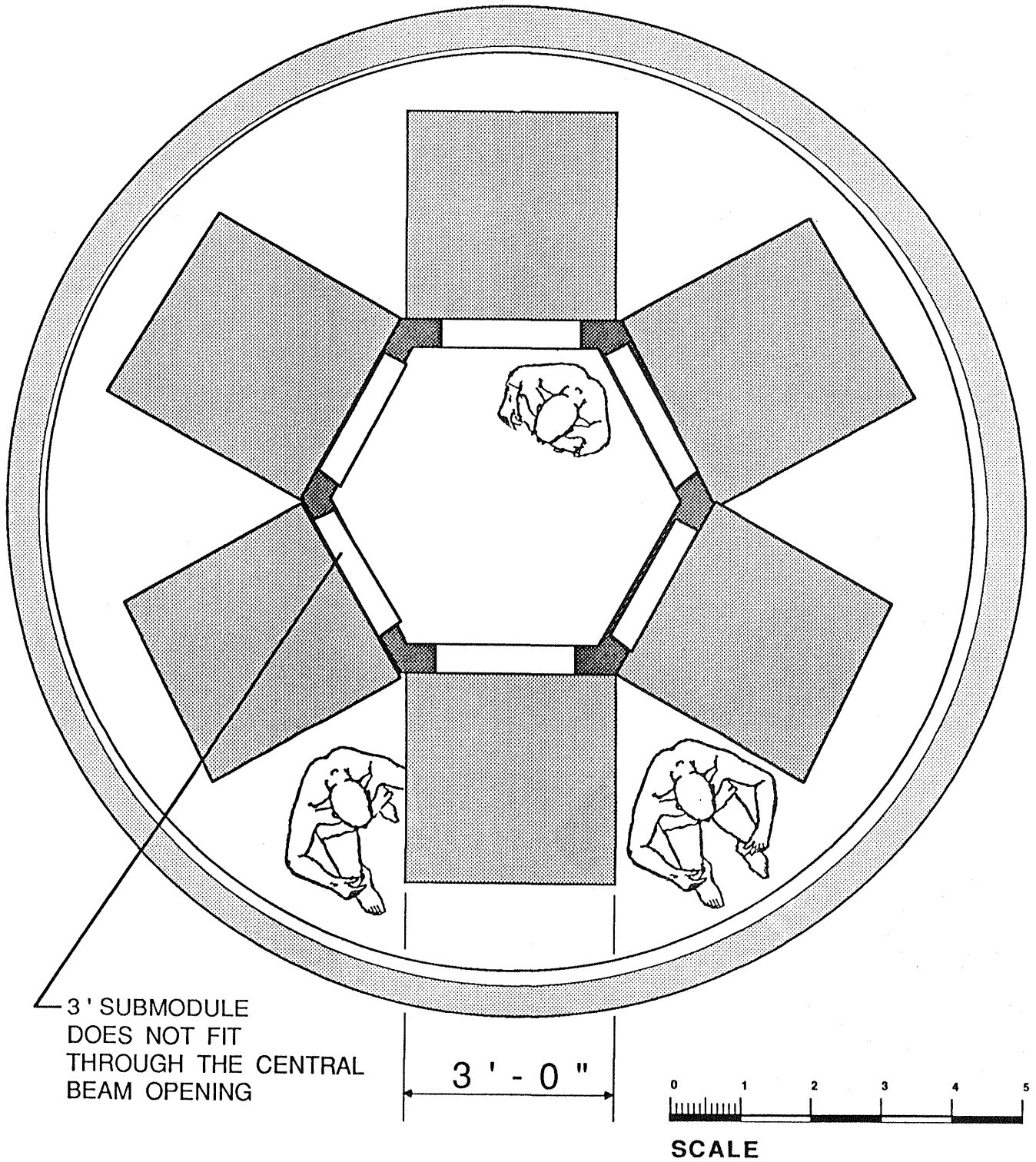
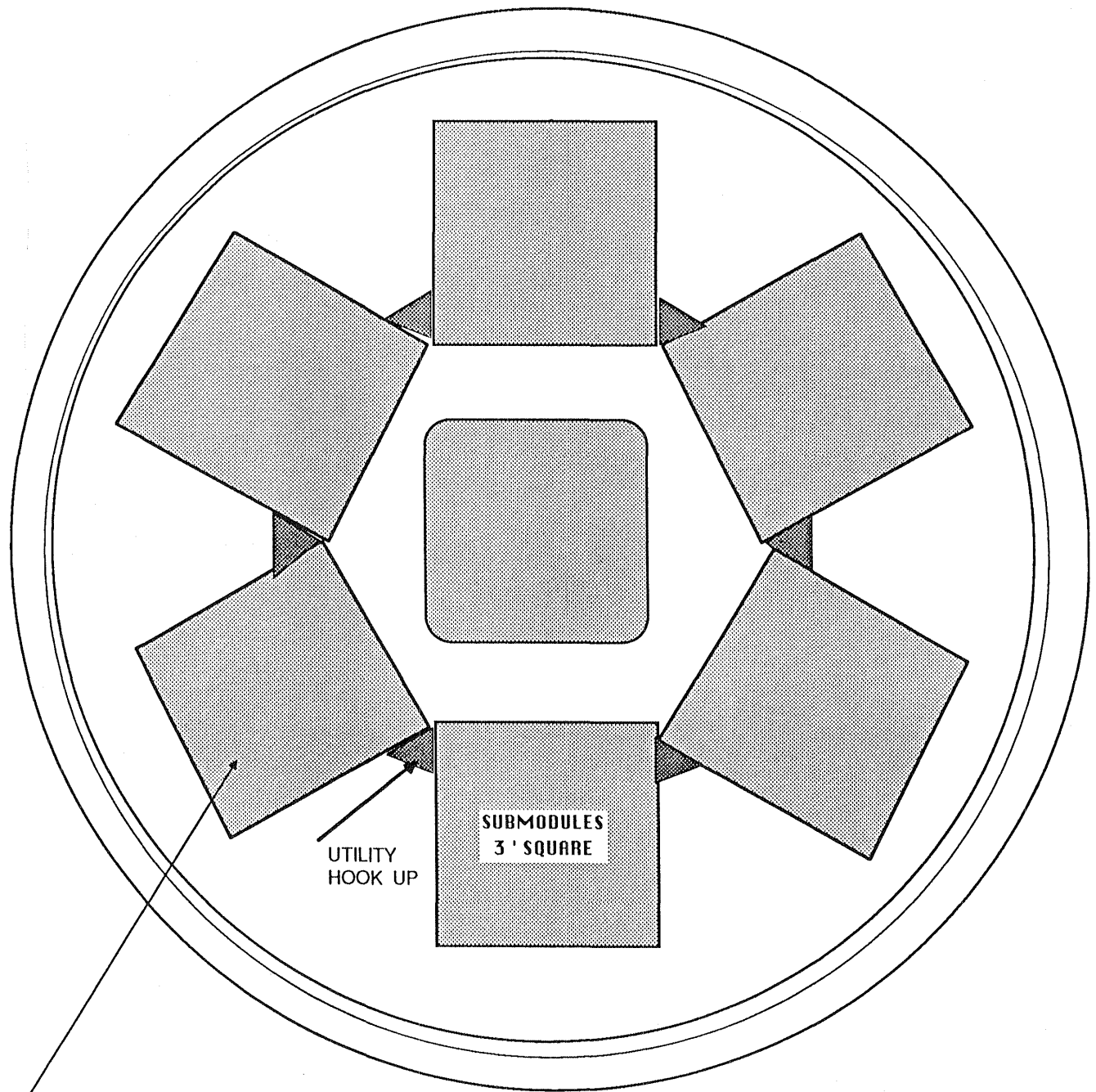

Figure 53 Hex Beam - Small Diameter Sizing

HEXAGON BEAM - LARGE SECTION



UNITS SLIP THROUGH BEAM
OPENING TO PERMIT
TRANSPORT ALONG CENTERLINE



SCALE

Figure 54 Hex Beam - Expanded Diameter

HEXAGONAL - LARGER THAN 4 FEET

Photograph-15 shows a larger than 4 feet hexagonal shaped interior with a scaled human figure. The submodules are expanded and attached to six utility chases to form a center translation interior with little access to the exterior skin of the module. The individual submodules are able to be pulled quickly from the permanent location next to the skin and permit human access to the module skin in the event of an emergency. The submodules are sized to translate through the opening at centerline and each submodule can interface with two of the utility chases. This is an advantage because the utilities required for the station may require two separate and distinct utility chases for safety reasons. This would mean the two types of utility chases could alternate in the six utility locations.

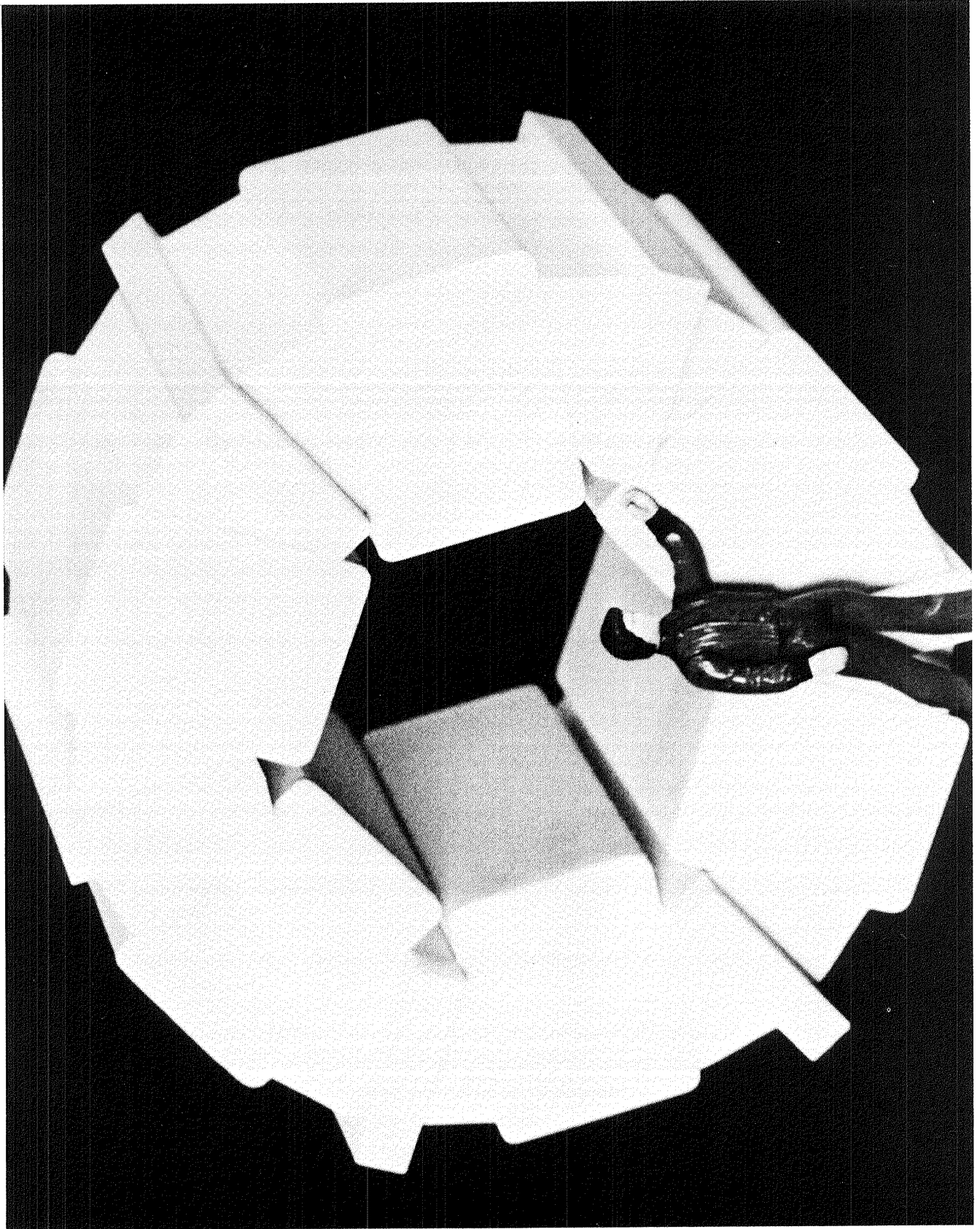

Photograph-15 Larger Hexagonal Beam with Human Form

HEXAGONAL BEAM WITH EXPANDED SUBMODULES

Photograph-16 shows a larger than 4 feet hexagonal shaped interior with expanded submodules. The submodules are expanded and attached to six utility chases to form a massive additional barrier of equipment surrounding the center translation interior. It does create additional effort to gain access to the exterior skin of the module. The individual submodules are able to be pulled quickly from the permanent location next to the skin and permit human access to the module skin in the event of an emergency. The submodules are sized to translate through the opening at centerline.

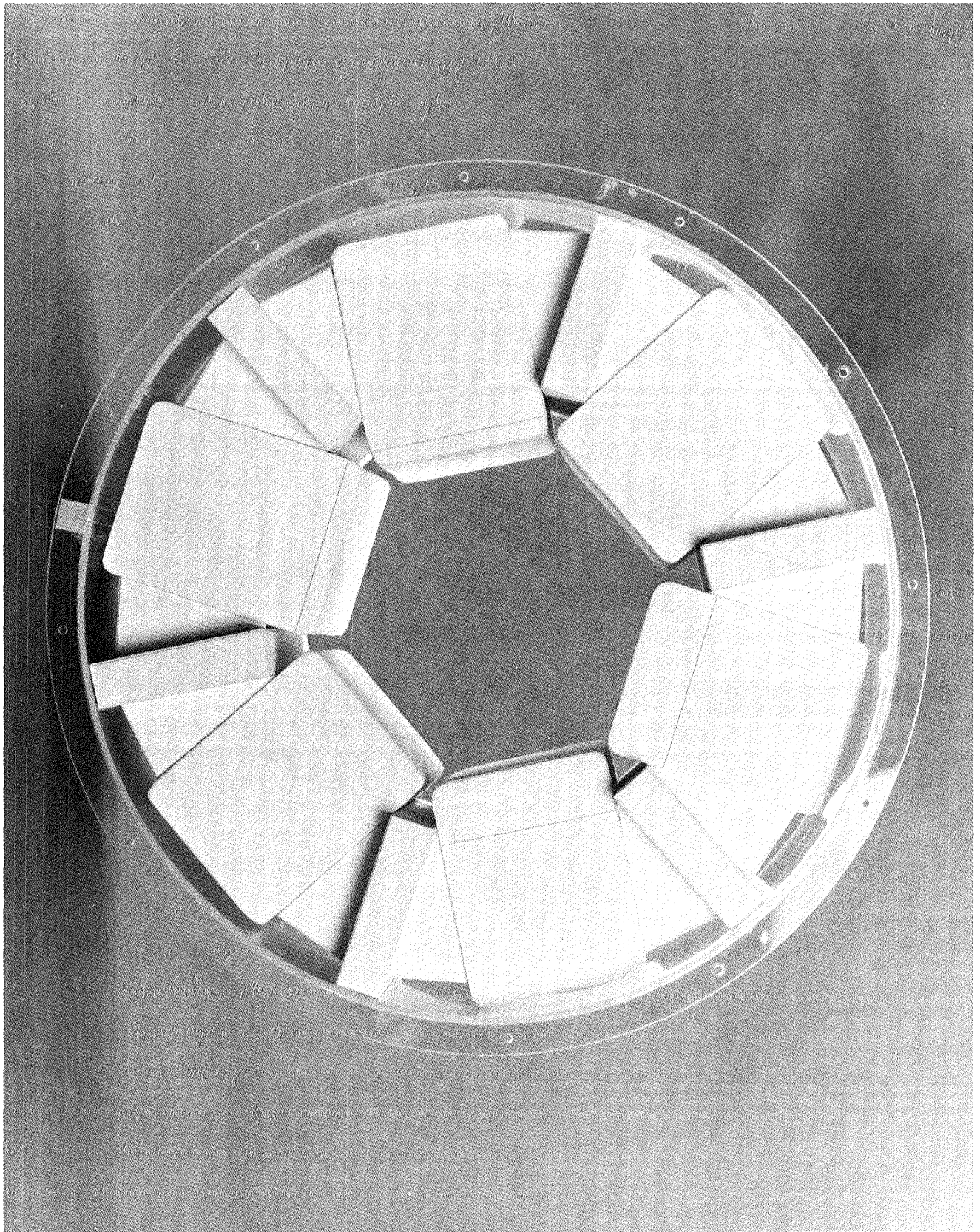

Photograph-16 Larger Hexagonal Beam with Expanded Submodules

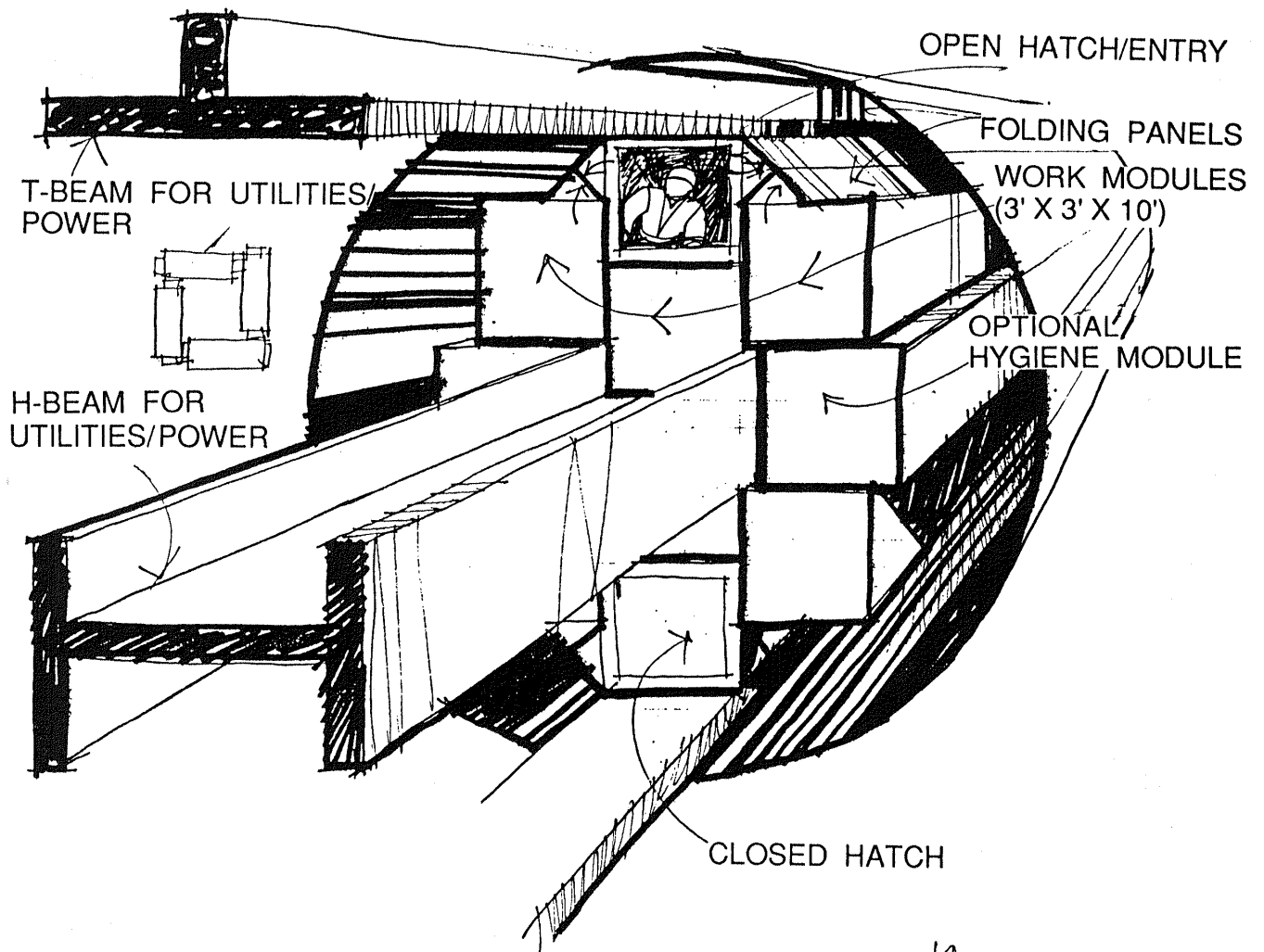

CONCEPT FOR LARGE WORK STATION

Figure 55 H Beam Concept

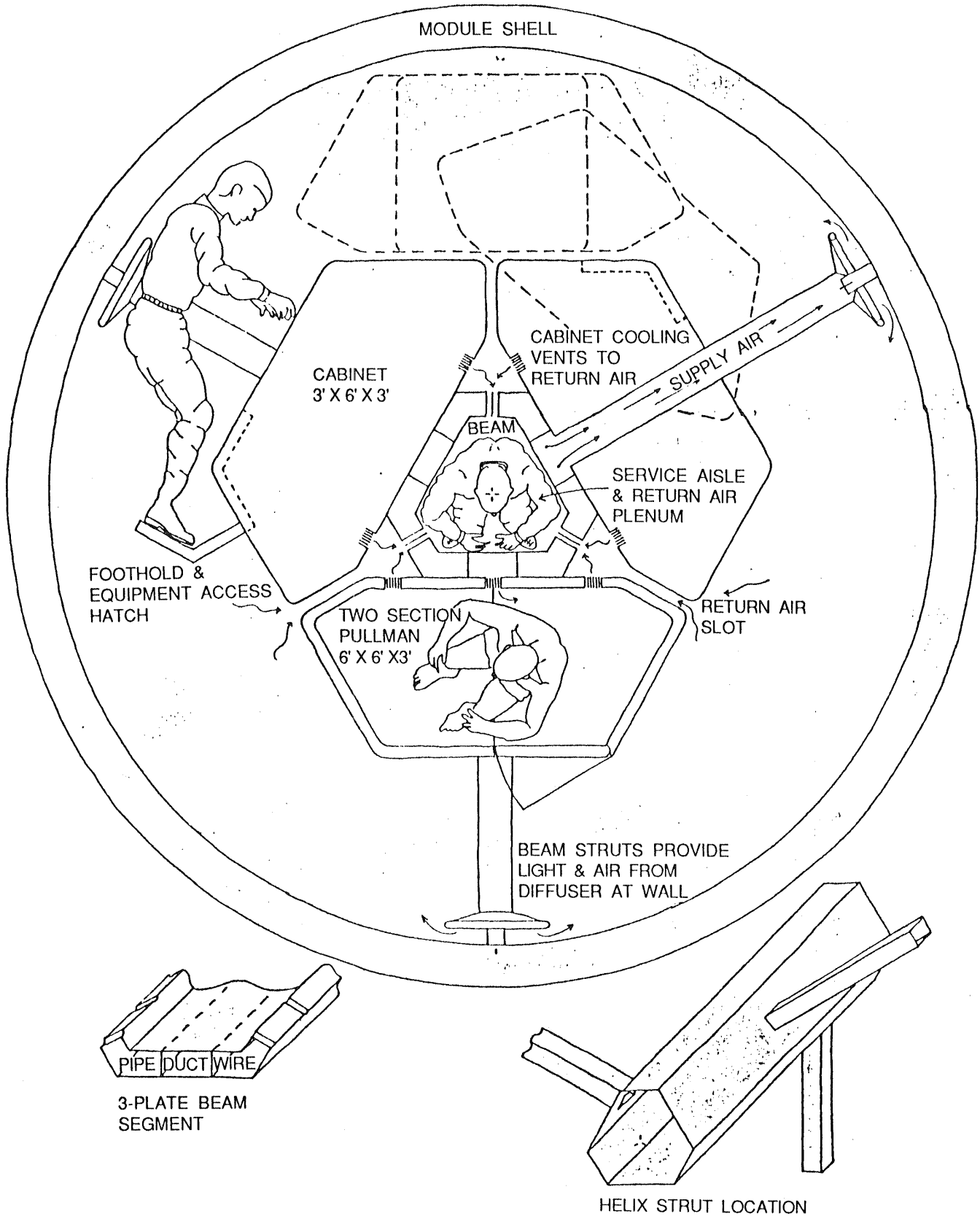
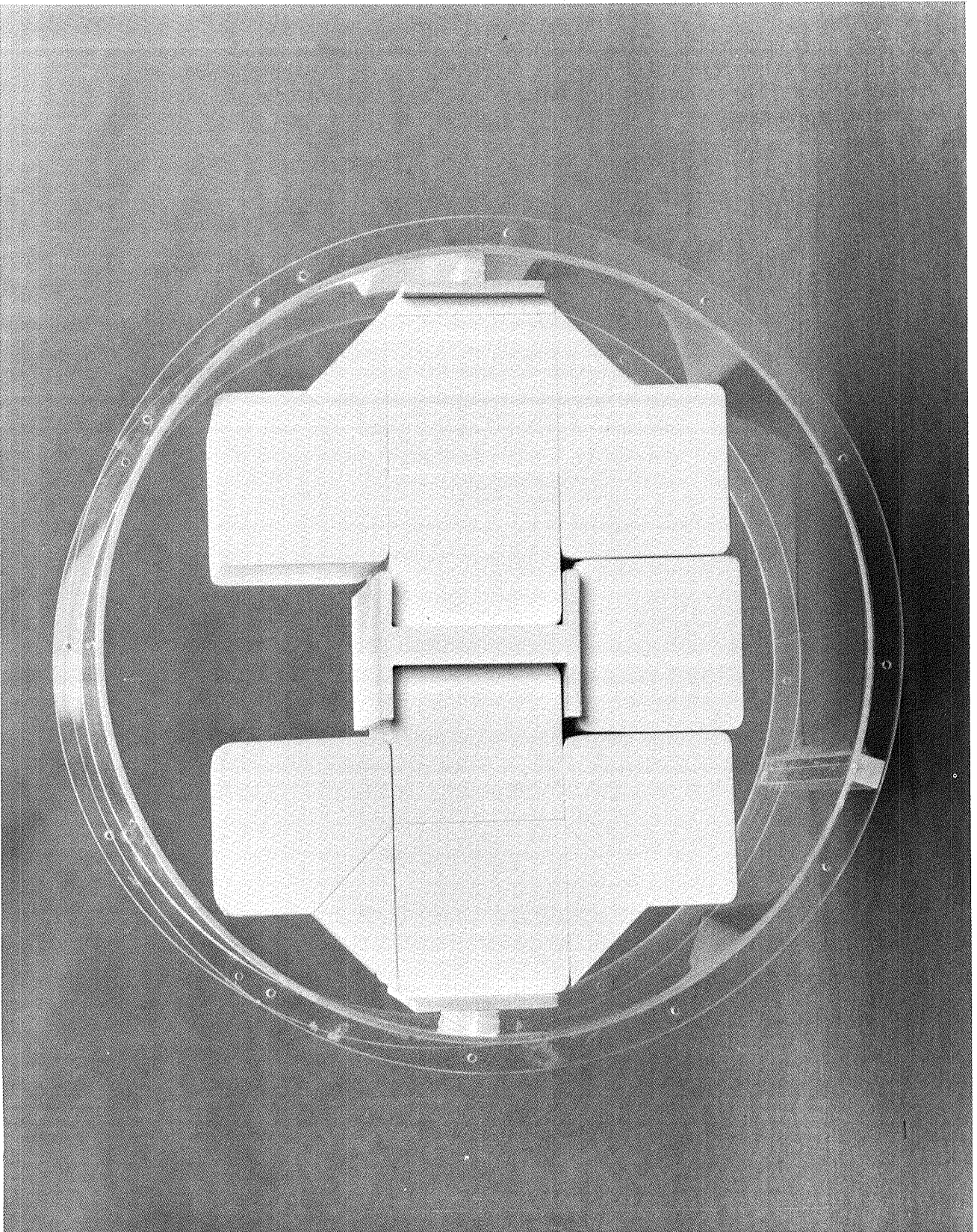

Figure 56 Dense Pack Triangular

H BEAM - LOCATED IN THE CENTER

Photograph-17 illustrates the H beam concept with a large utility structure in the center of the module and smaller utility chases down two sides. This permits a separation of the difficult utilities and a method of accommodating the somewhat larger Common Module Control Workstation. One flange of the H beam is left open for translation of humans and change out of submodules.



Photograph-17 H Beam Concept Located in the Center

H BEAM - LOCATED IN THE CENTER

Photograph-18 illustrates the H beam concept with a human form to permit the reader to see the large translation region at the center of the module and smaller human crawl volumes down the sides. The second human is difficult to see in the smaller volume opposite the translation volume.

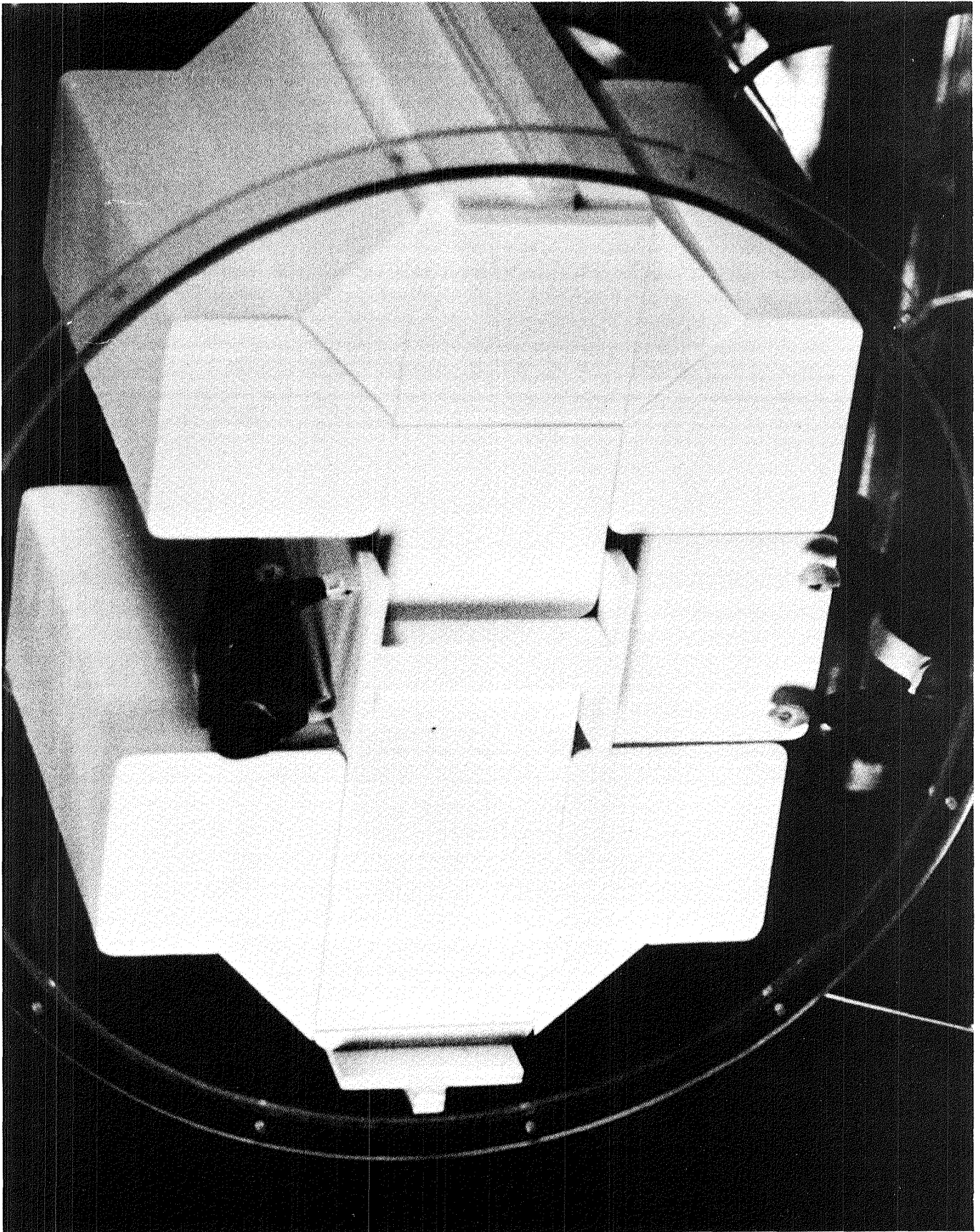

Photograph-18 H Beam Concept with Human Forms

HEXAGONAL BEAM - MEDIUM

Photograph-19 illustrates the Hexagonal Beam clustered around the centerline. The key to this configuration is the variety it provides. The center triangular shaped core permits utilities and humans to function in the utility core. It permits humans to go into the utility core and interface with the hook-up, maintenance, repair and disconnect of the utilities.

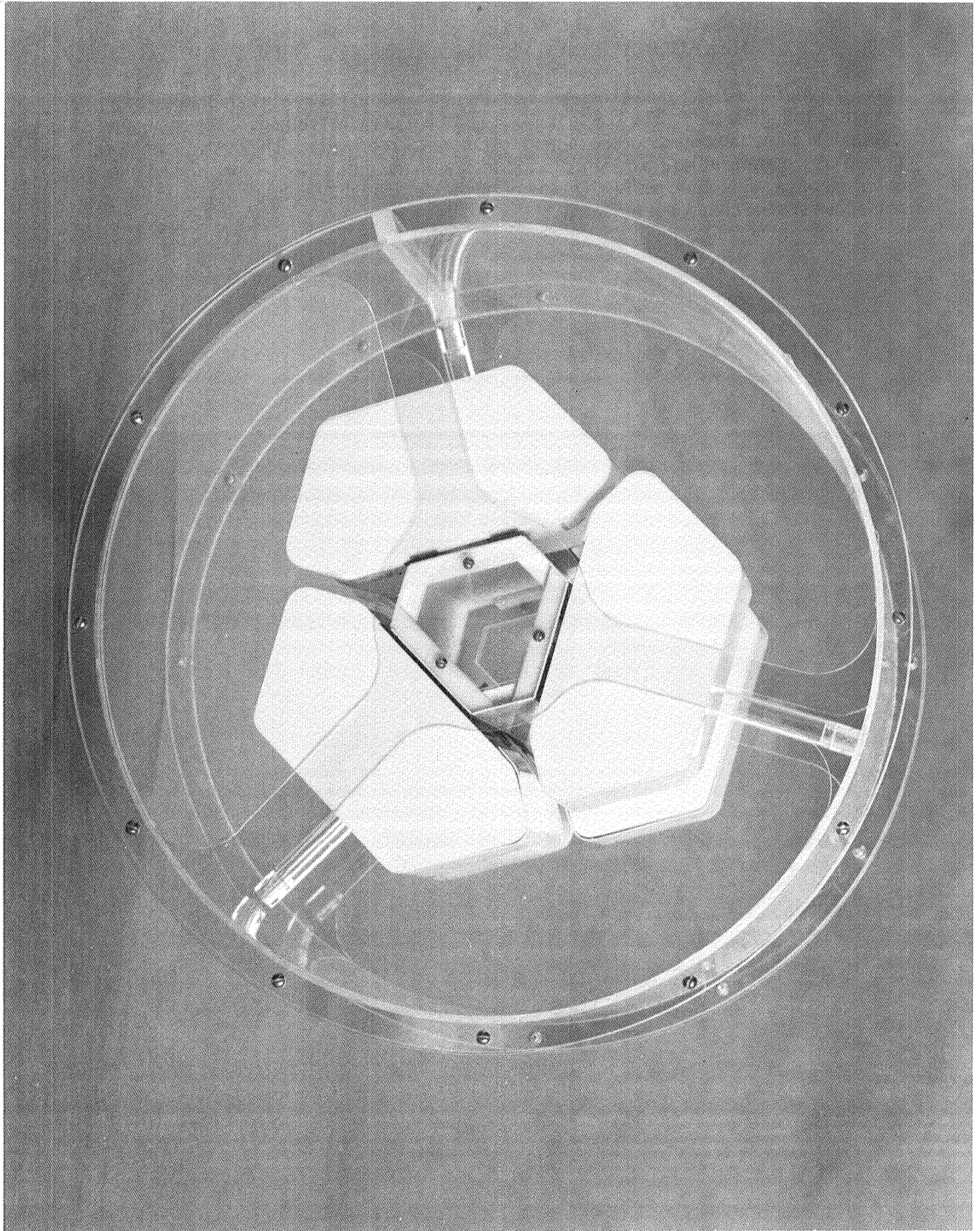

Photograph-19 Hexagonal Beam Concept with Triangular Core

HEXAGONAL BEAM - SUBMODULE CHANGEOUT

Photograph-20 illustrates the Hexagonal Beam with the submodules clustered around the centerline triangular core. The key to this configuration is the movement of the changeout submodule along the outside of the in place submodules it provides. The center triangular shaped core permits utilities and humans to function in the utility core. It permits humans to changeout a submodule next to the skin of the module. In the facing photograph the reader can see the changeout module.

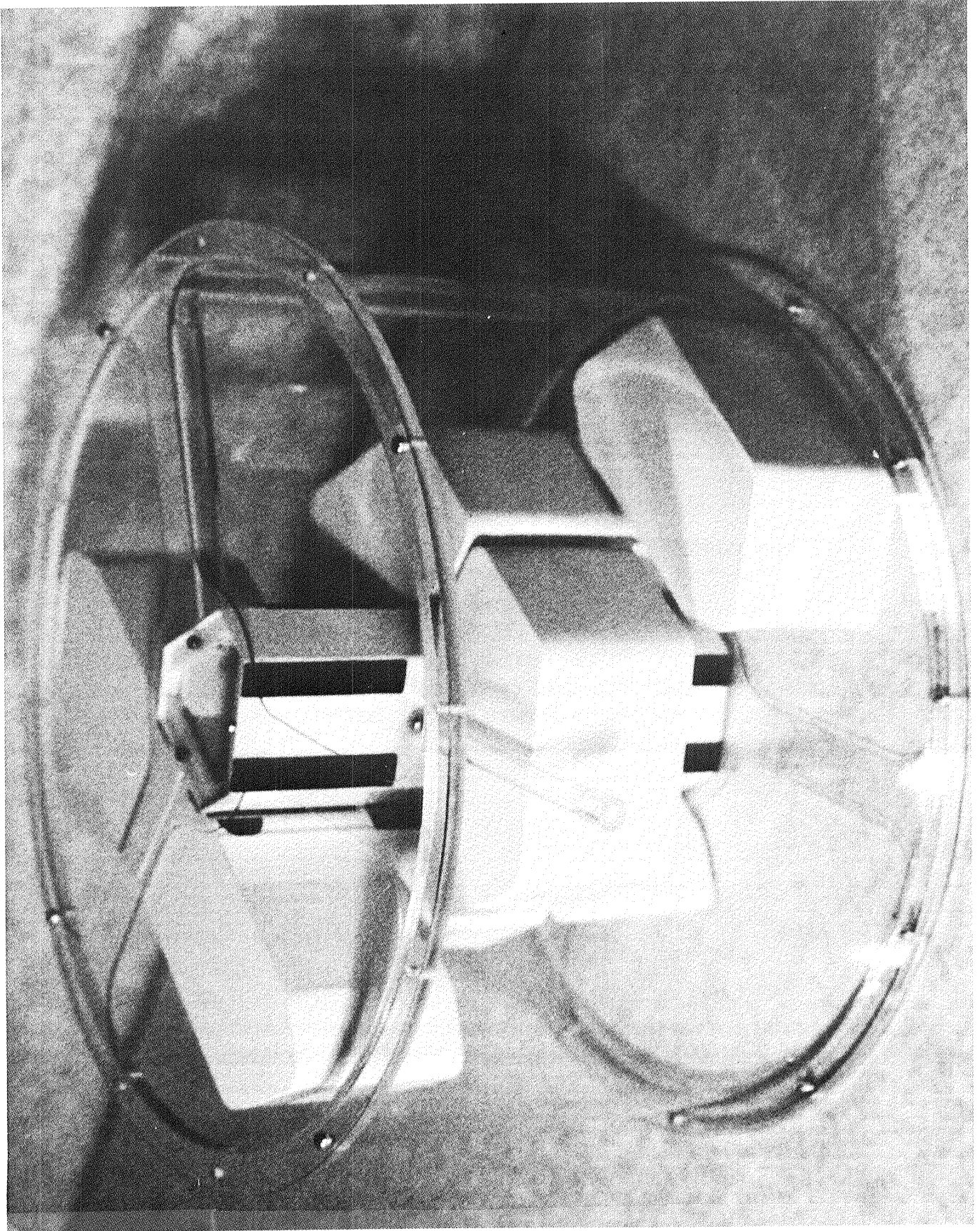

Photograph-20 Hexagonal Beam Concept with Submodule Changeout

HEXAGONAL BEAM - SUBMODULE EXPANDED

Photograph-21 illustrates the Hexagonal Beam with the submodules expanded. The key to this configuration is the expansion capability of the submodule along the outside of the submodules. The center triangular shaped core permits utilities and humans to function in the utility core and the volume outside the submodules to be partially used. In the facing photograph the reader can see the expanded submodule modeled in clear plastic.

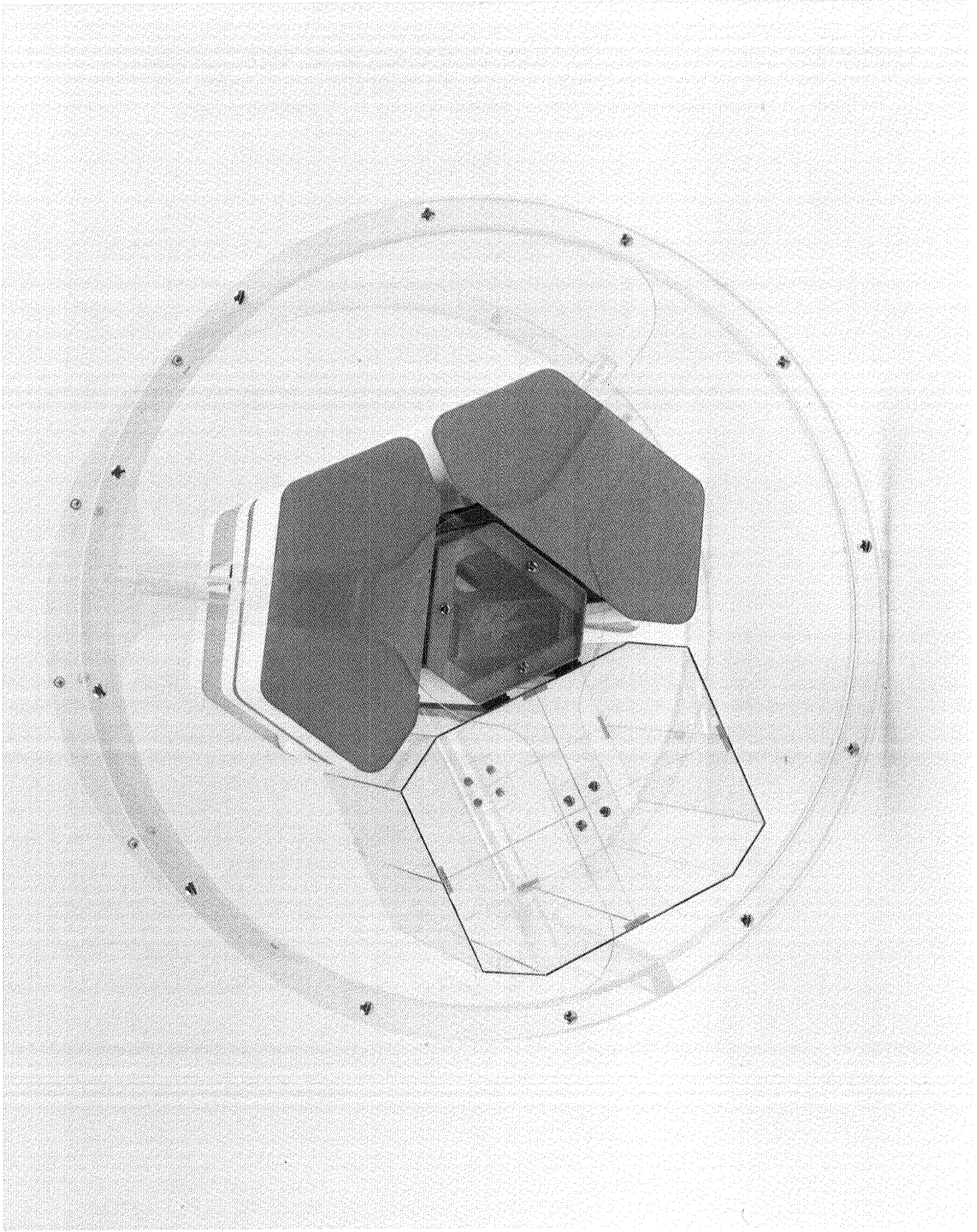

Photograph-21 Hexagonal Beam Concept with Submodule Expanded

HEXAGONAL BEAM - WITH HUMAN LIKE FORM

Photograph-22 illustrates the Hexagonal Beam with the submodules expanded with a human like Gumby form scaled to be similar to the human shape. The key to this configuration is the all around access capability to the submodule from all sides. In the facing photograph the reader can see the human Gumby form and submodule modeled in clear plastic.

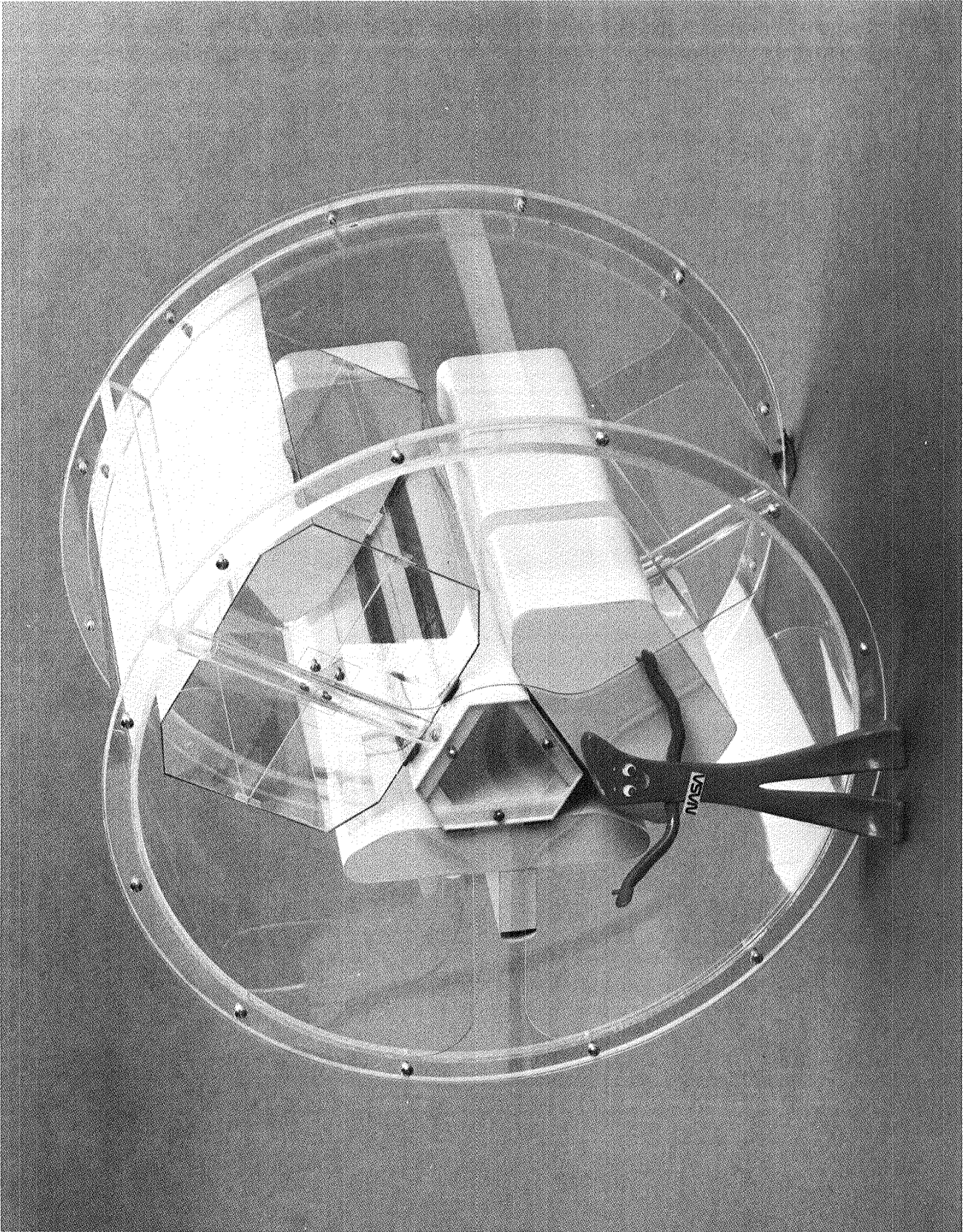

Photograph-22 Hexagonal Beam Concept with Human Like Form

HEXAGONAL BEAM WITH VARIABLE SIZE SUBMODULES

Photograph-23 illustrates the Hexagonal Beam with the submodules of different shape. The key to this configuration is the variety of sizes permitted. In the facing photograph the reader can see some of the different sizes possible.

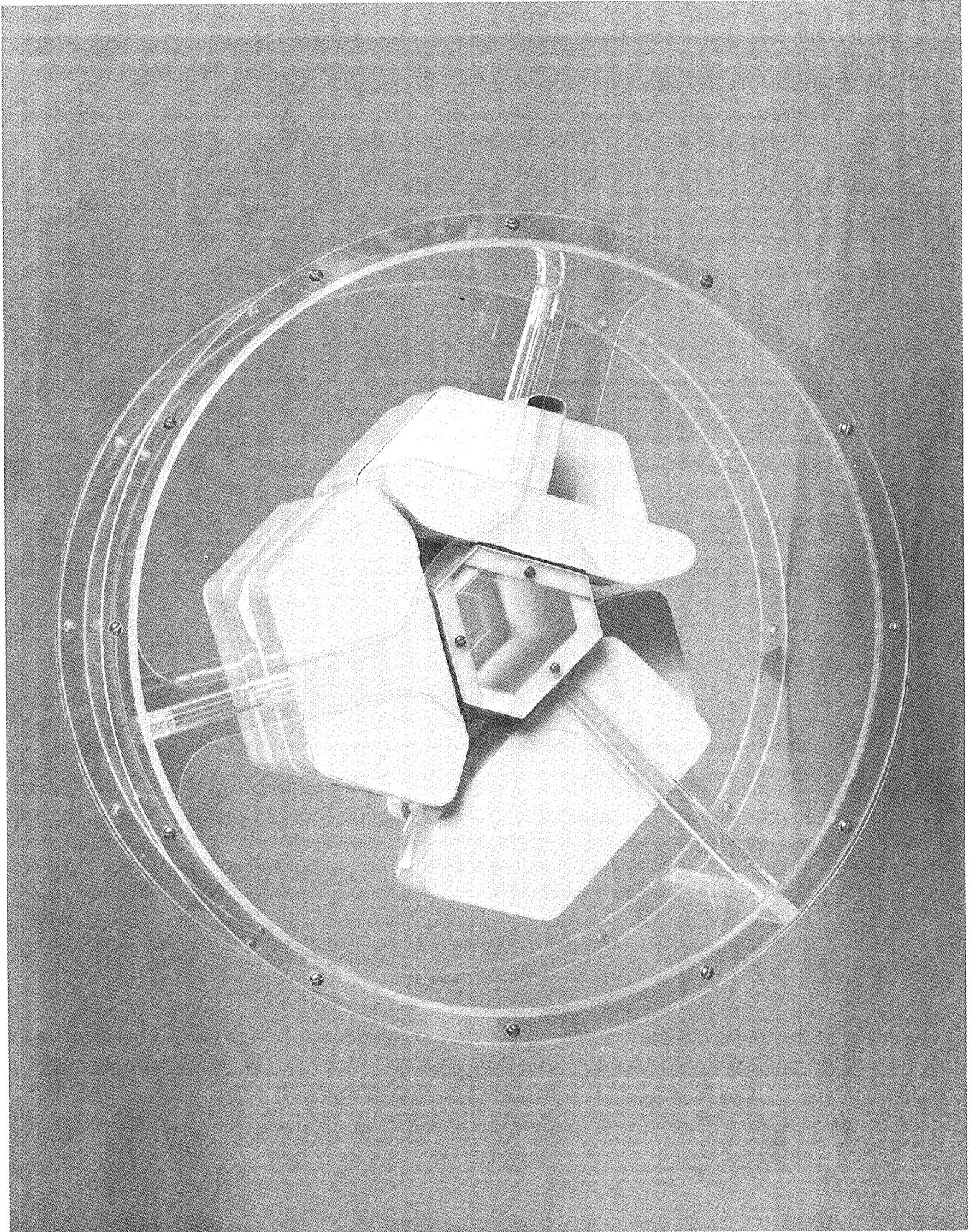

Photograph-23 Hexagonal Beam Concept with Variable Sized Submodules

HEXAGONAL BEAM WITH GAP BETWEEN SUBMODULES

Photograph-24 illustrates the Hexagonal Beam with some distance between the submodules of different shape. The key to this configuration is the access space permitted. In the facing photograph the reader can see some of the different configurations possible.

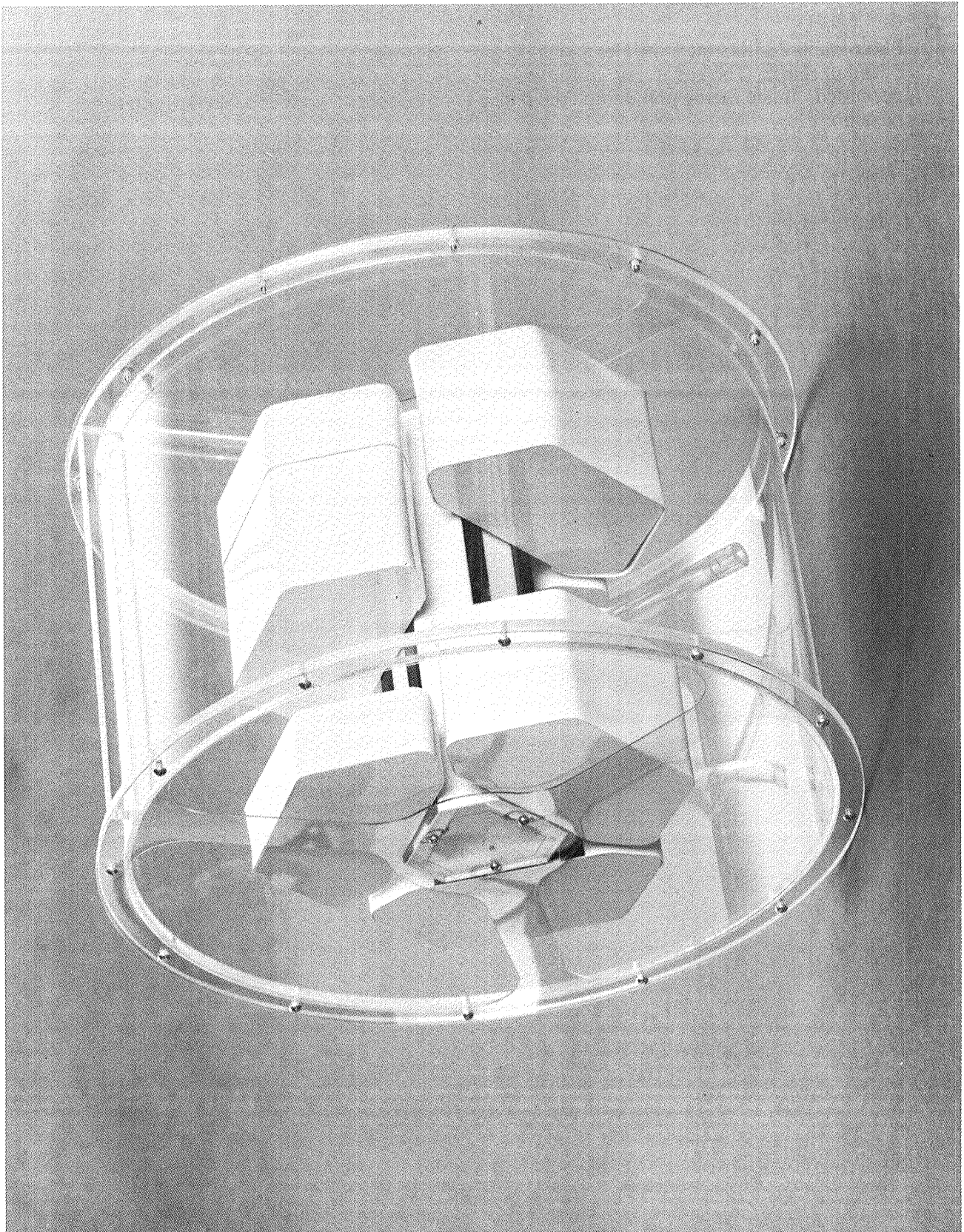

Photograph-24 Hexagonal Beam Concept with Gaps Between Submodules

HEXAGONAL BEAM WITH OVERSIZED SUBMODULES

Photograph-25 illustrates the Hexagonal Beam with some oversized submodules of different shape. The key to this configuration is the oversized volume submodules permitted. In the facing photograph the reader can see the end view of one configuration possible.

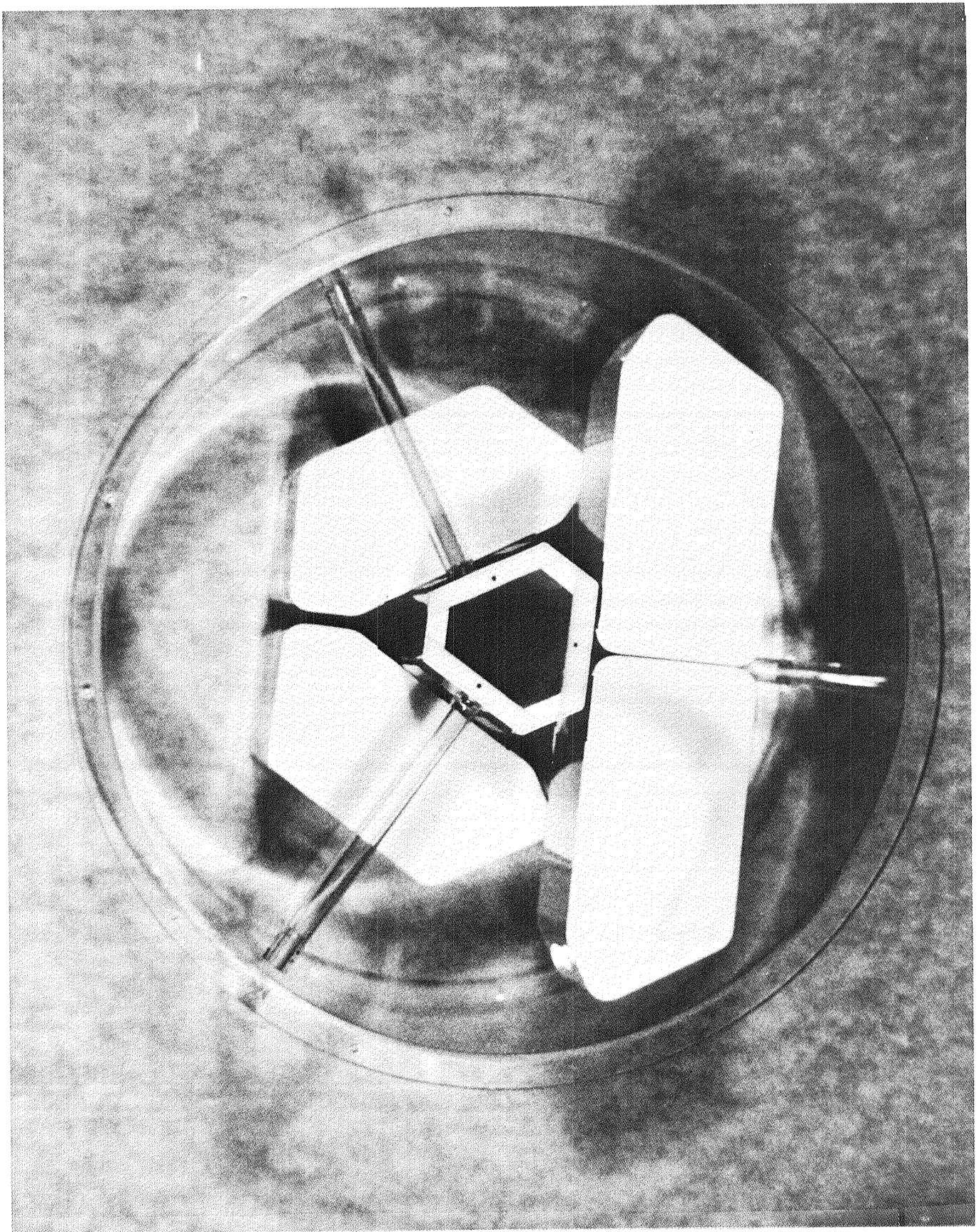

Photograph-25 Hexagonal Beam Concept with Oversized Submodules

HIGH DENSITY OPTION
BIG HEX BEAM
CENTER BEAM MODEL LAYOUT

AIR DUCT 8' ON CENTER

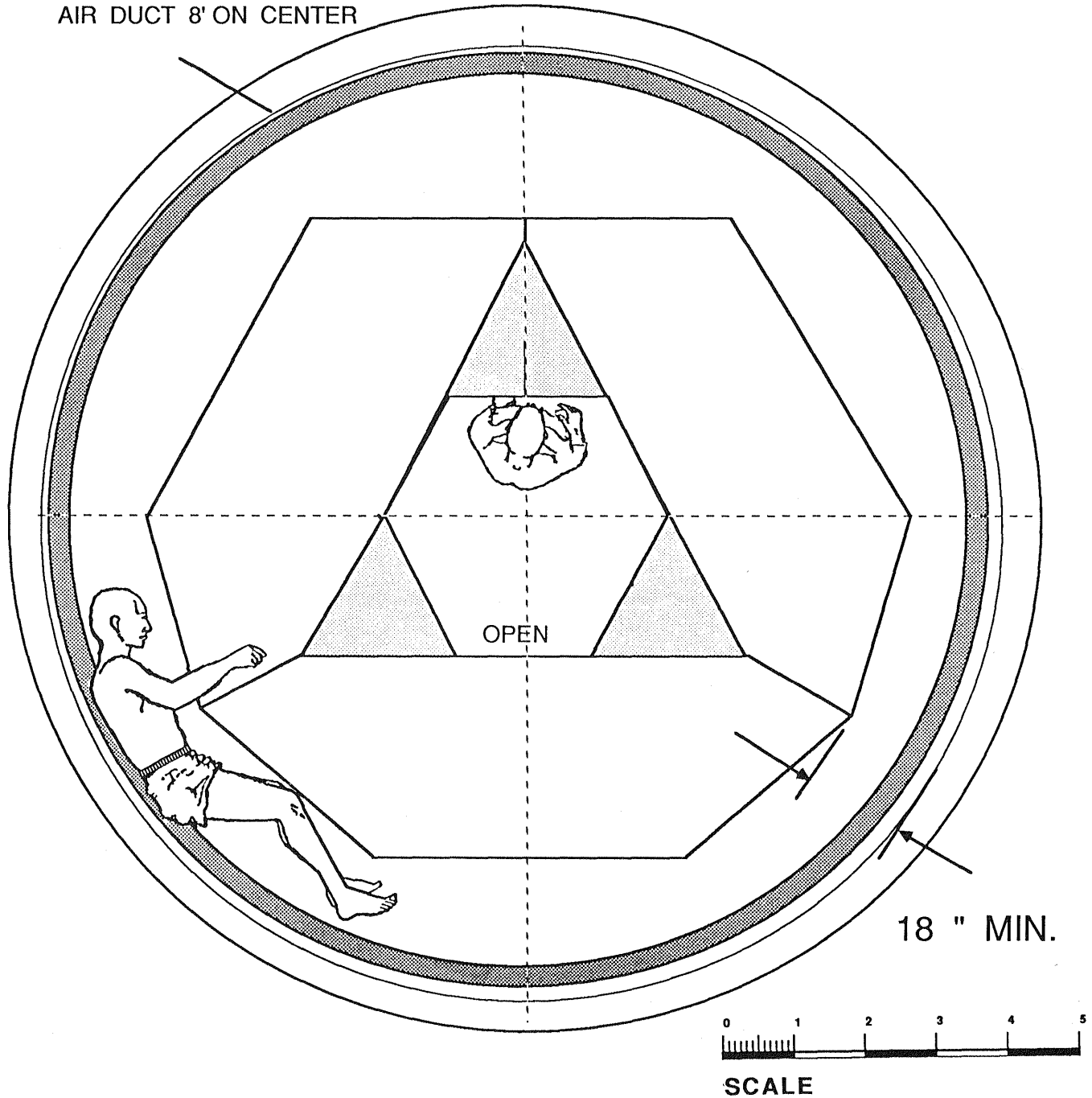

Figure 57 Dense Pack - Expanded

COMMON MODULE APPLICATIONS

The Common Module is the logical application point of the central beam configurations under study. The transition section from the various beam cross-sections to the end cap hatch is a subject for future model contracts and additional research. Figure 58 attempts to depict the complex transitions required for this area. Details of this transition on one of the beam sections are shown in Figure 59.

The racetrack configuration shown in Figure 60 can develop a minimum travel path from one module to another. The figure assumes a "local vertical" as away from center and uses an off center end cap to create a minimum module to module travel time path. The value of the small changes is difficult to calculate exactly, but one example may help. In a thirty year design life of a joint between two common modules with an average crew of 20 people making 10 trips a day and saving 5 seconds per trip from module to module due to the "Minimum Travel" design, an approximate saving of \$ 9,700 a day or a total \$ 106 million savings could be envisioned for the 30 year design life. (Based on a labor hour cost of \$ 35,000/hr).

ENGINEERING WORKSTATION

The Engineering Workstation in model form is shown in Figure 61. It will be based on the 3' x 3' x 7' standard submodule shown in Figure 62.

BEAM MODELS

The beam configurations will be fabricated in 8.8 inch segments designed to fit within one module model straight section as shown in Figure 63. The Triangular Beam - On Center is shown as an example in Figure 64. The model fabrication system uses a technique designed to limit the glue and permanent fastening to the furnished NASA model shell. See Figure 65 for details and Figure 66 for the materials used. A Beam Comparison Table is shown in Figure 67. It roughly calculates the square footage in the cross section devoted to each use. The unexpanded volume includes submodules, utilities and support structure, which are all capable of passage through the assumed 50 inch circular D shaped hatch. The utility volume is in parenthesis. The expanded volume includes all the above unexpanded volume plus the additional volume obtained through various expanded or pull out submodules. The expanded submodules will not fit through the assumed hatch in the expanded condition. The passage way volume is that allocated as passage way volume. The negative volume is difficult to use volume and requires, for example, movement of equipment to examine and repair damage in this inner module skin region. The total of columns 2, 3 and 4 should in each case add to a total of 140 square feet of cross sectional area, which is based on a scaled interior diameter of 160.5 inches. The NASA furnished 13.38 inch interior diameter models were fabricated in advance of the Space Station decision to fabricate the common modules with a 166 inch I.D. Both the Spacelab and Space Station diameters are adjusted to the 160.5 inch I.D. for comparison purposes. Figure 68 illustrates the model shell used and examples of the parameters used in the comparison. The percentage of negative volume to total volume is shown in the next column in Figure 67. The final column contains the total useful equipment volume divided by the total volume. A rough Spacelab and Space Station four rack square design is also listed in Figure 67 to provide a comparison. The Space Station is based on currently available information and is subject to additional changes. Other model fabrication drawings are available and the index for those drawings is in Appendix A.

TRANSITIONAL SECTION OF UTILITY DISTRIBUTION

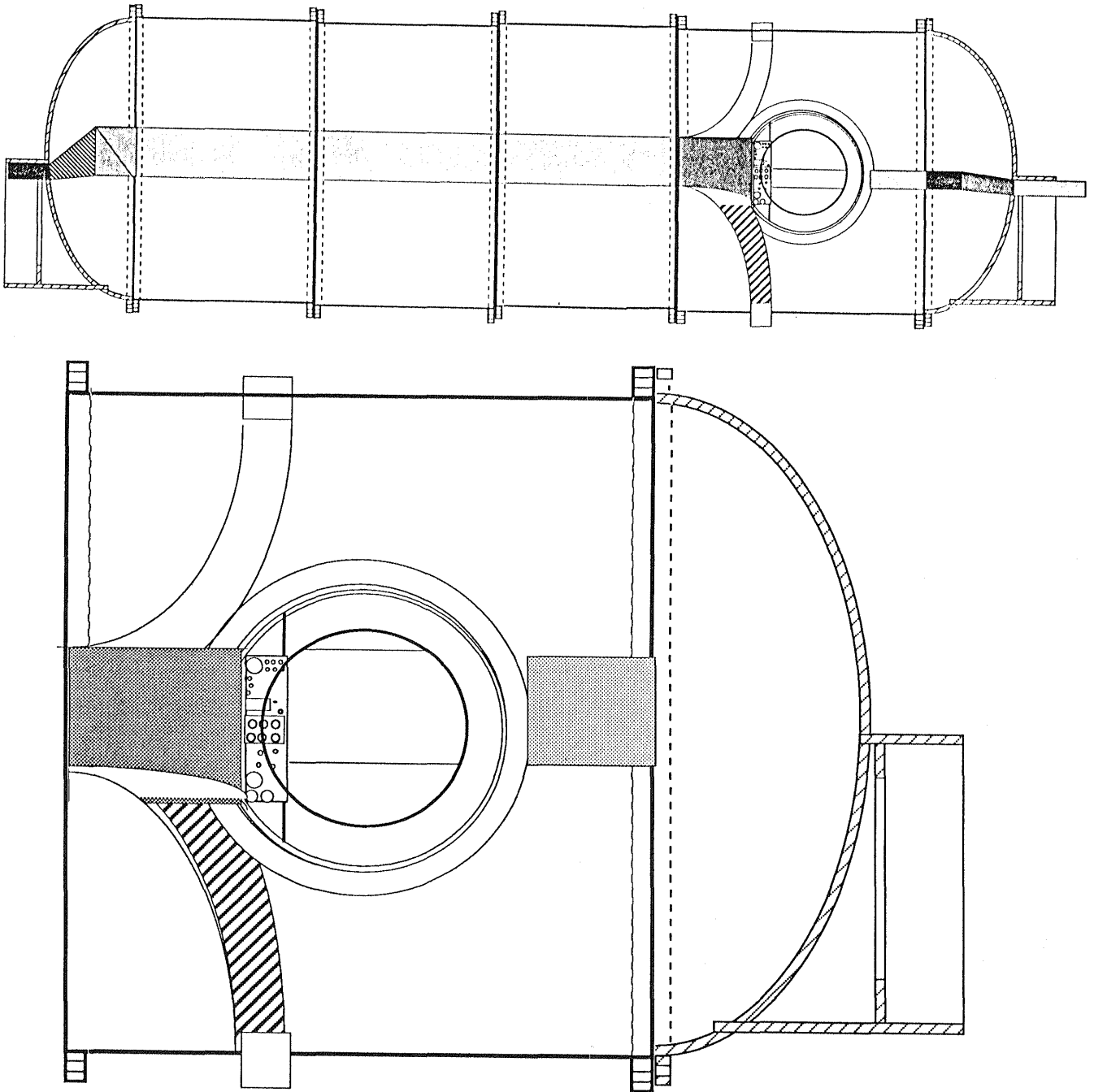

Figure 58 Utility Transition - Original Common Module

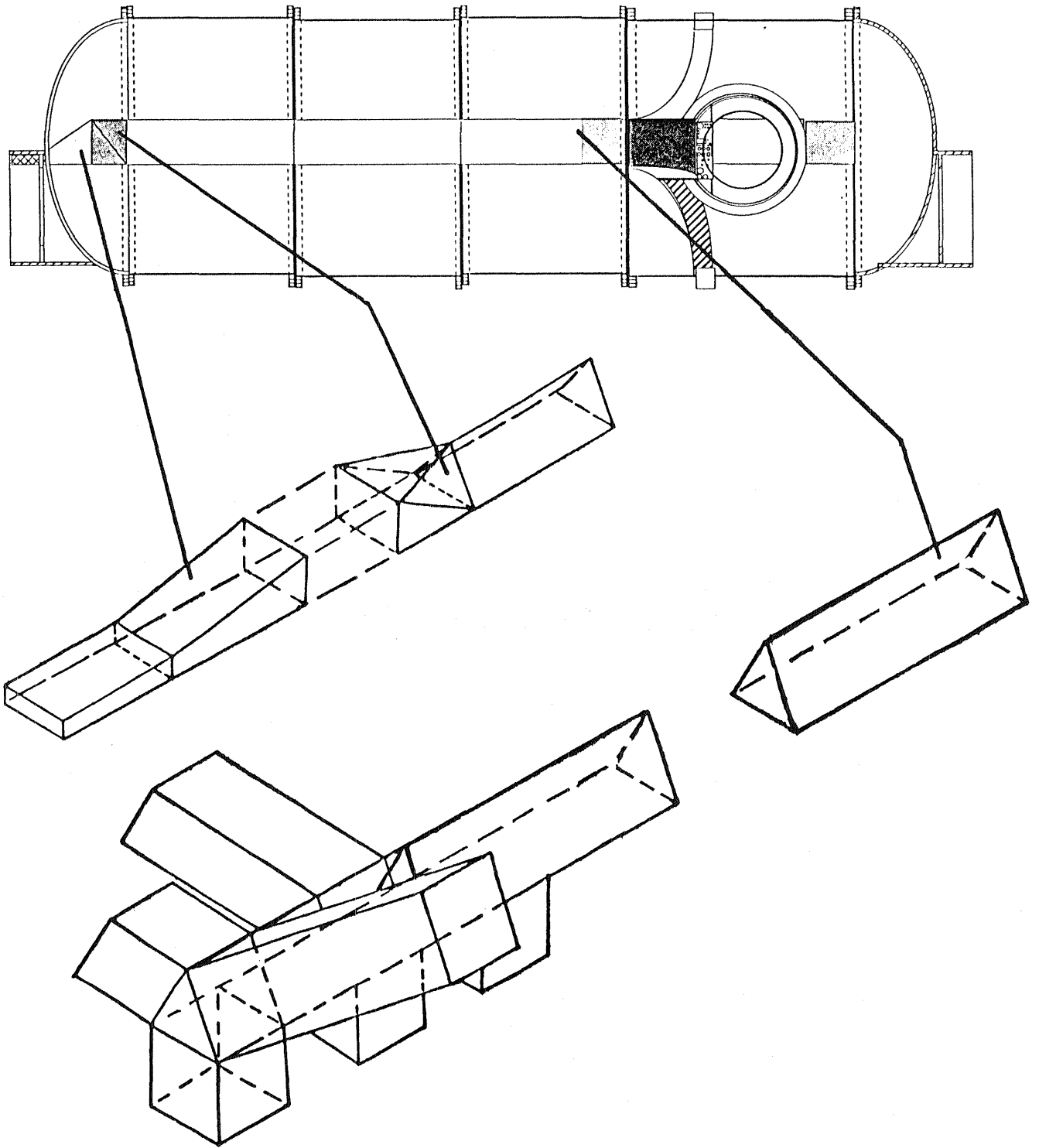

Figure 59 Transition Details

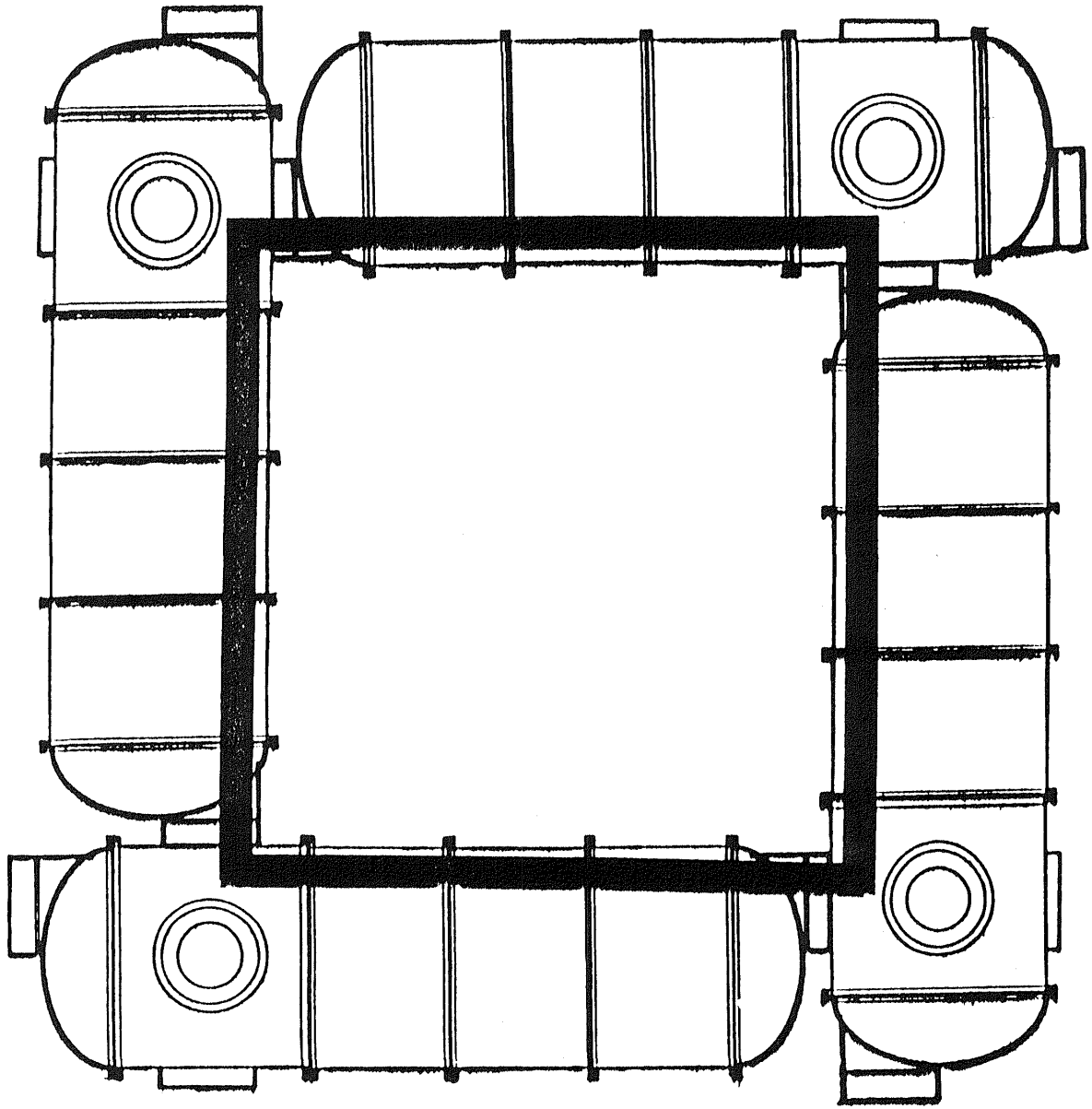

Figure 60 Racetrack - Minimum Crew Circulation Route

COMPRESSED ENGINEERING WORKSTATION

MIDDECK LOCKER
SIZED USER CHANGED
UNITS

USE ROUNDED CORNERS TO
CREATE A 3' X 3' X 7' CLEAR PLASTIC BOX

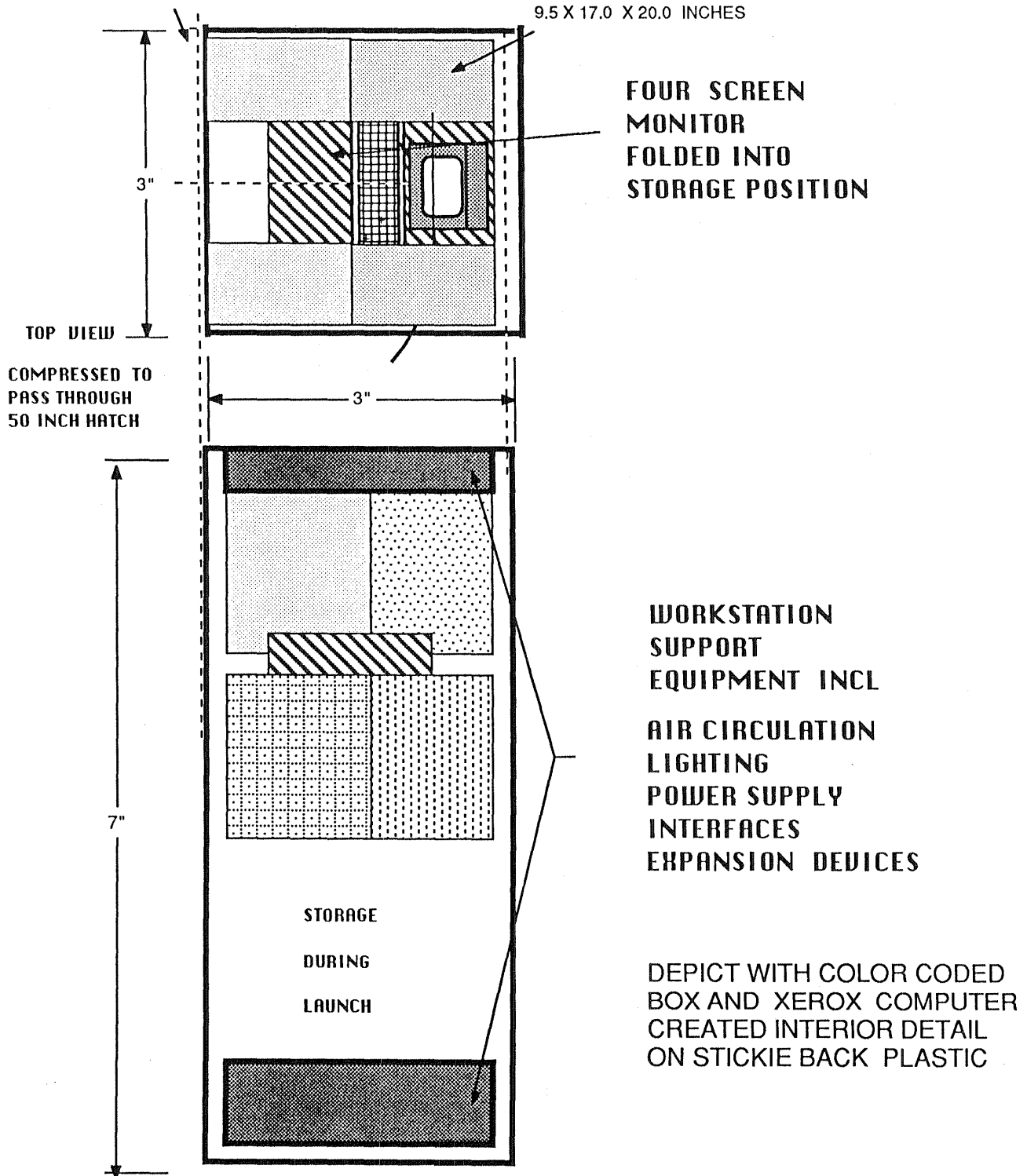

Figure 61 Engineering Workstation Model

ROUNDED CORNER TYPE SUB MODULE

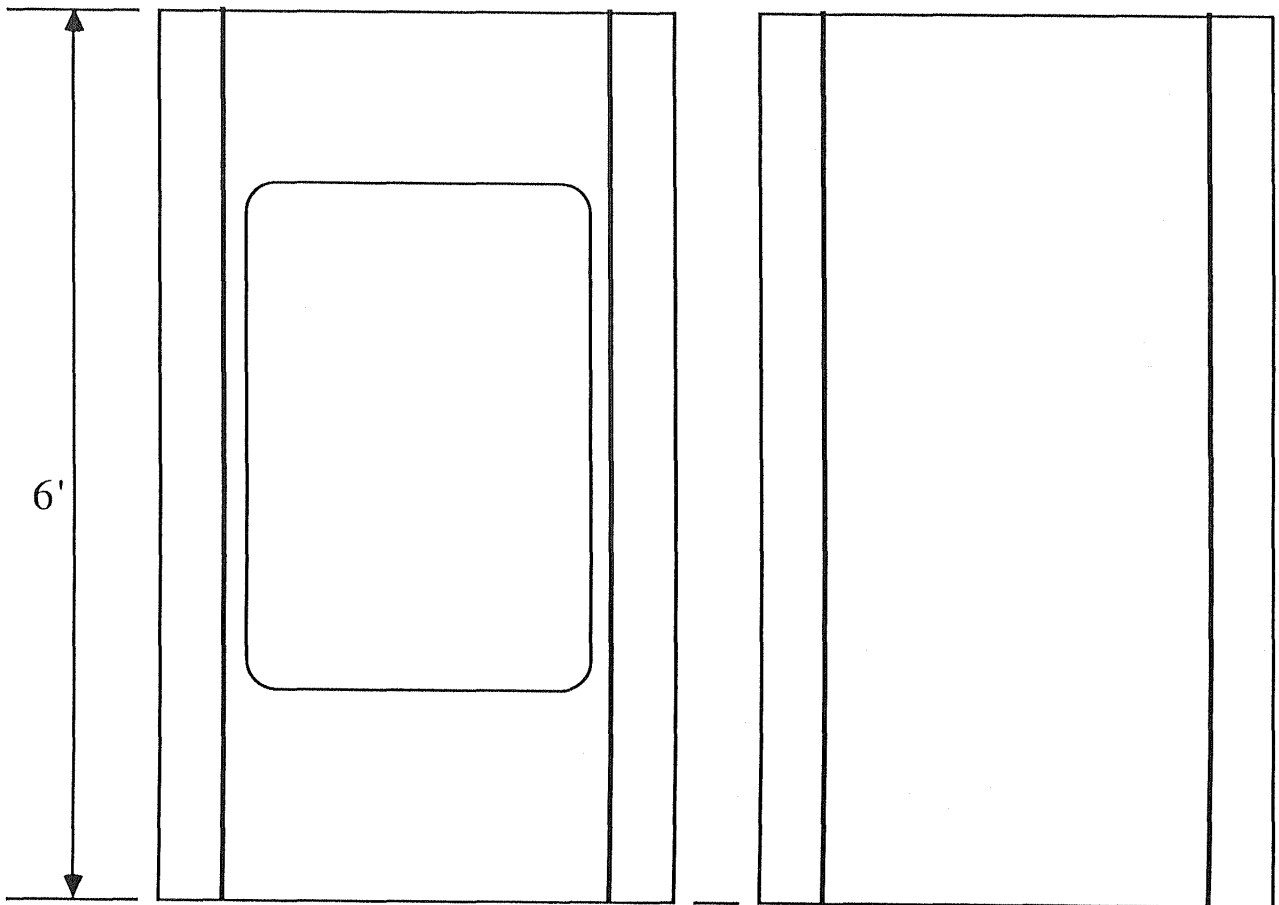
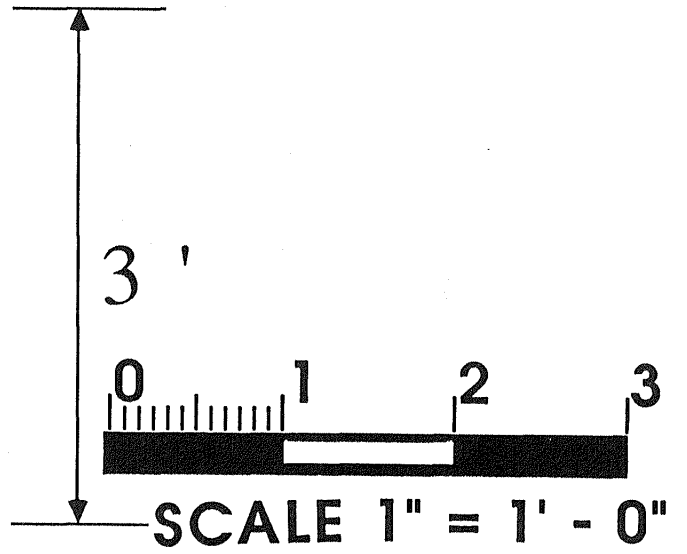
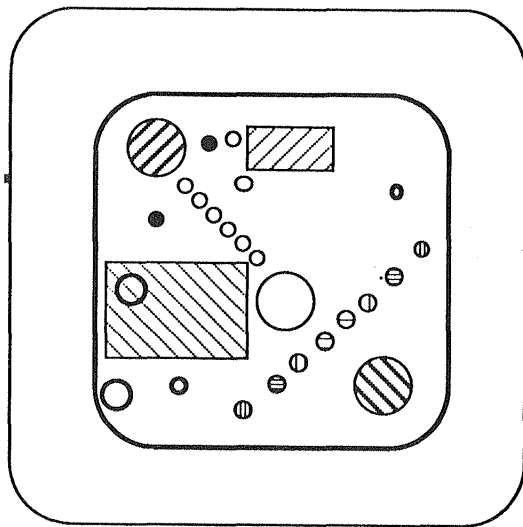

Figure 62 3' x 3' x 7' Submodule

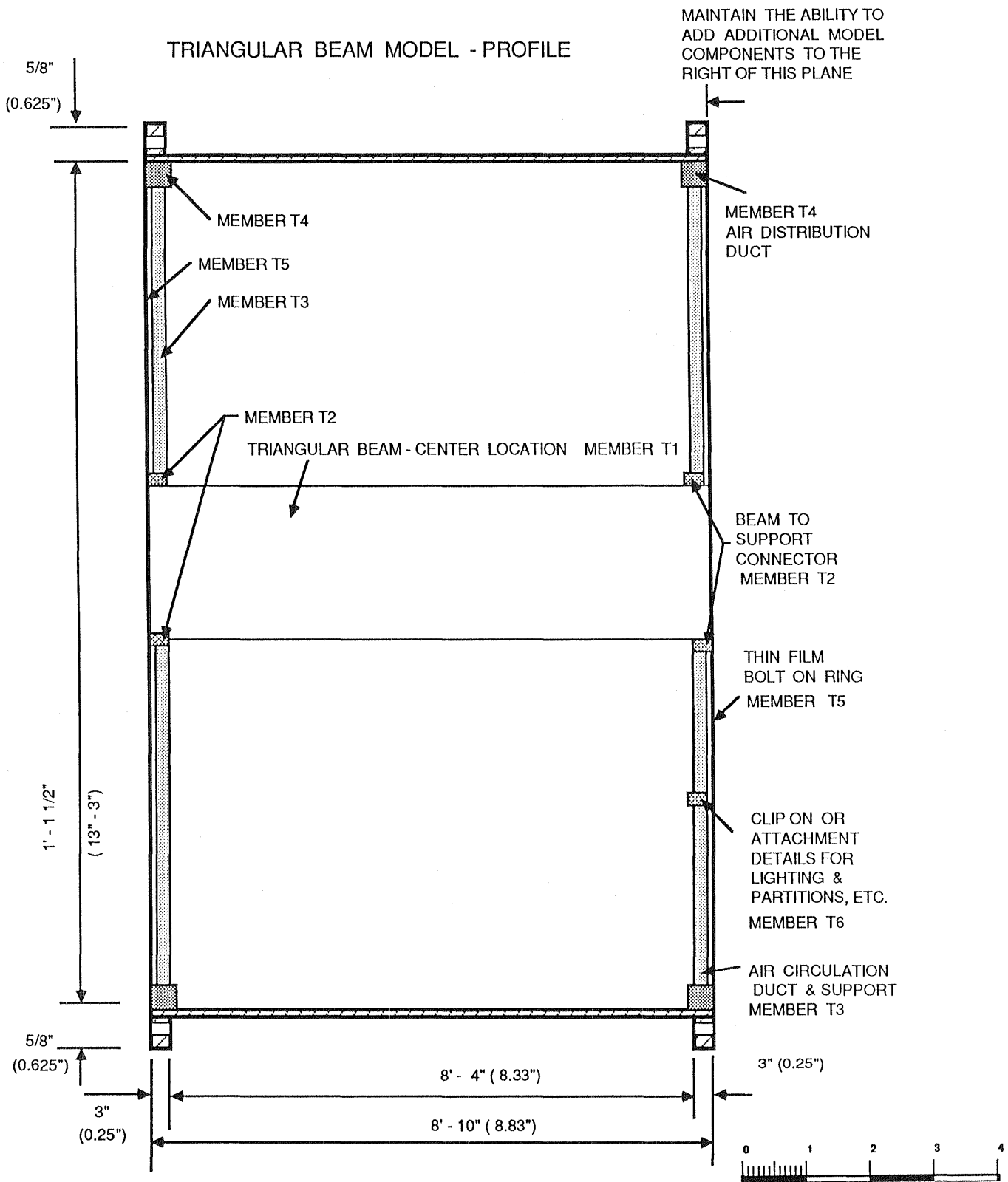

Figure 63 Beam Models - Example Drawing

TRIANGULAR BEAM
CENTER BEAM MODEL LAYOUT
SECTION

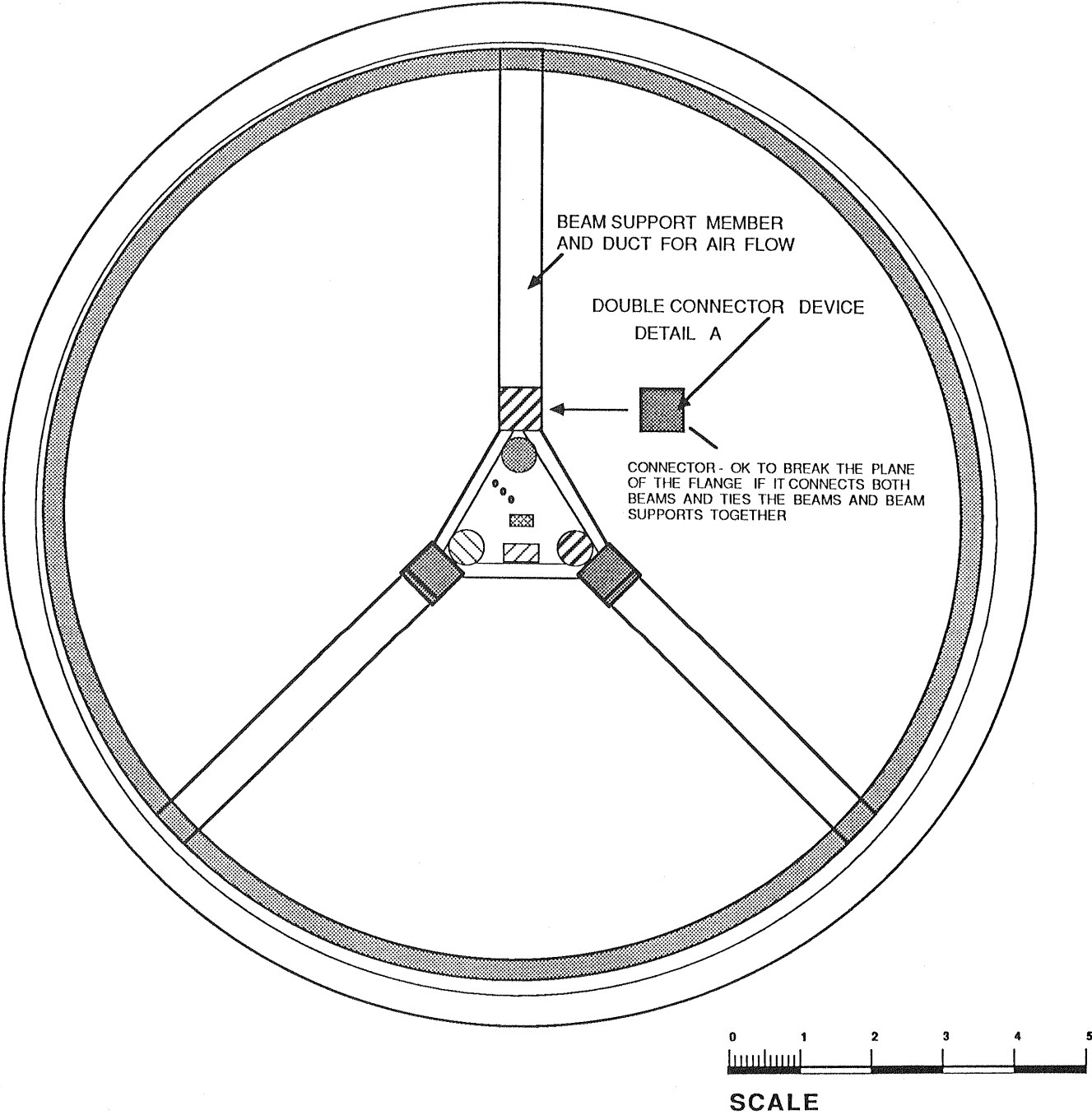
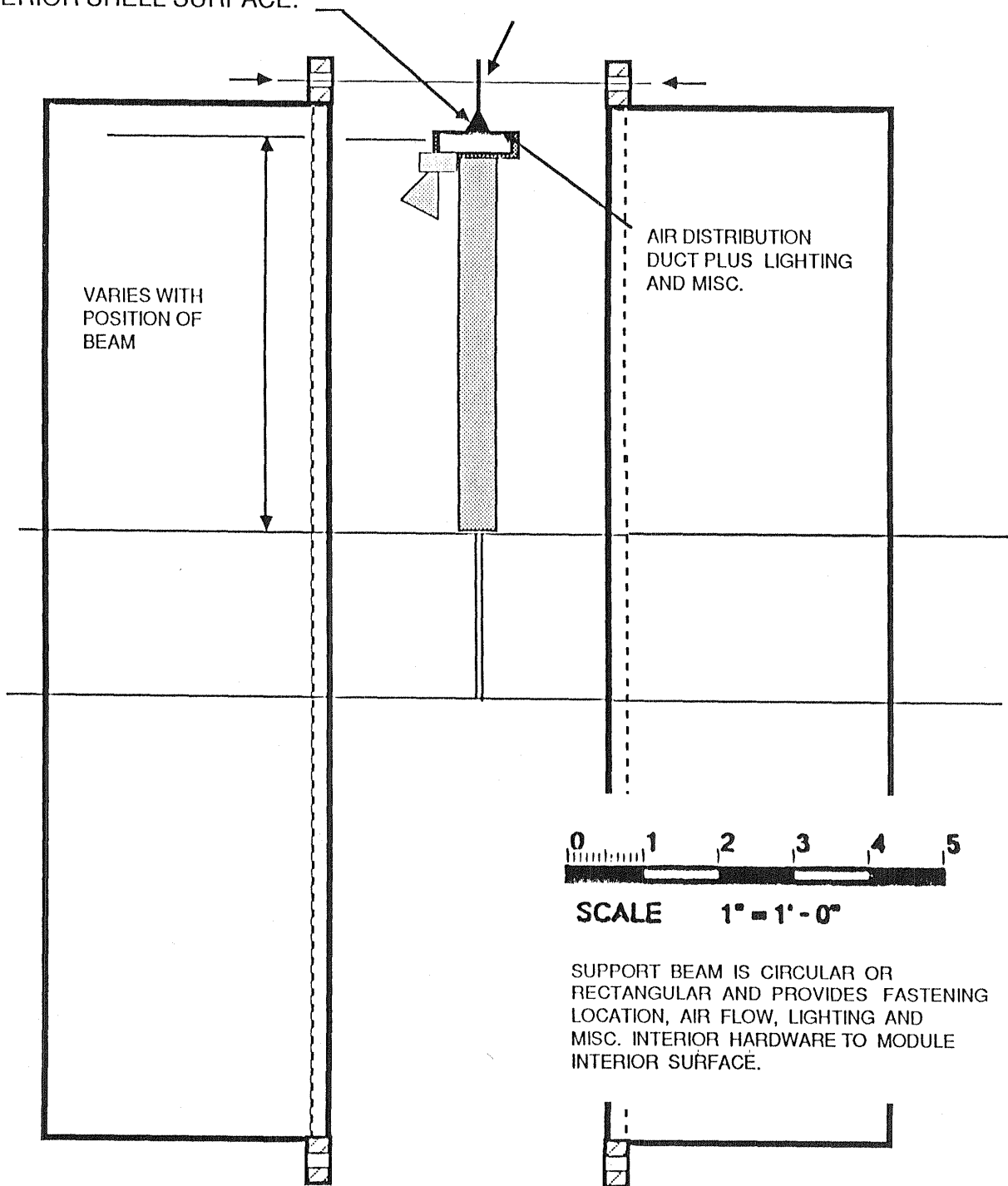

Figure 64 Triangular Beam Model Details

TRIANGULAR POINT BRACE
MINIMIZES THE CONTACT
TO THE SURFACE FOR
MAXIMUM ACCESS TO THE
INTERIOR SHELL SURFACE.

MODEL USES CLEAR PLASTIC SHEET RING
BOLTED BETWEEN THE GFE FLANGES SO
NO FASTENING TO PLASTIC EXTERIOR SHELL IS
REQUIRED. CLEAR PLASTIC SHEET IS THE
THICKNESS OF HEAVY PAPER.



MODEL FABRICATION - TRIANGULAR BEAM

Figure 65 Triangular Beam Model Example Fabrication Details

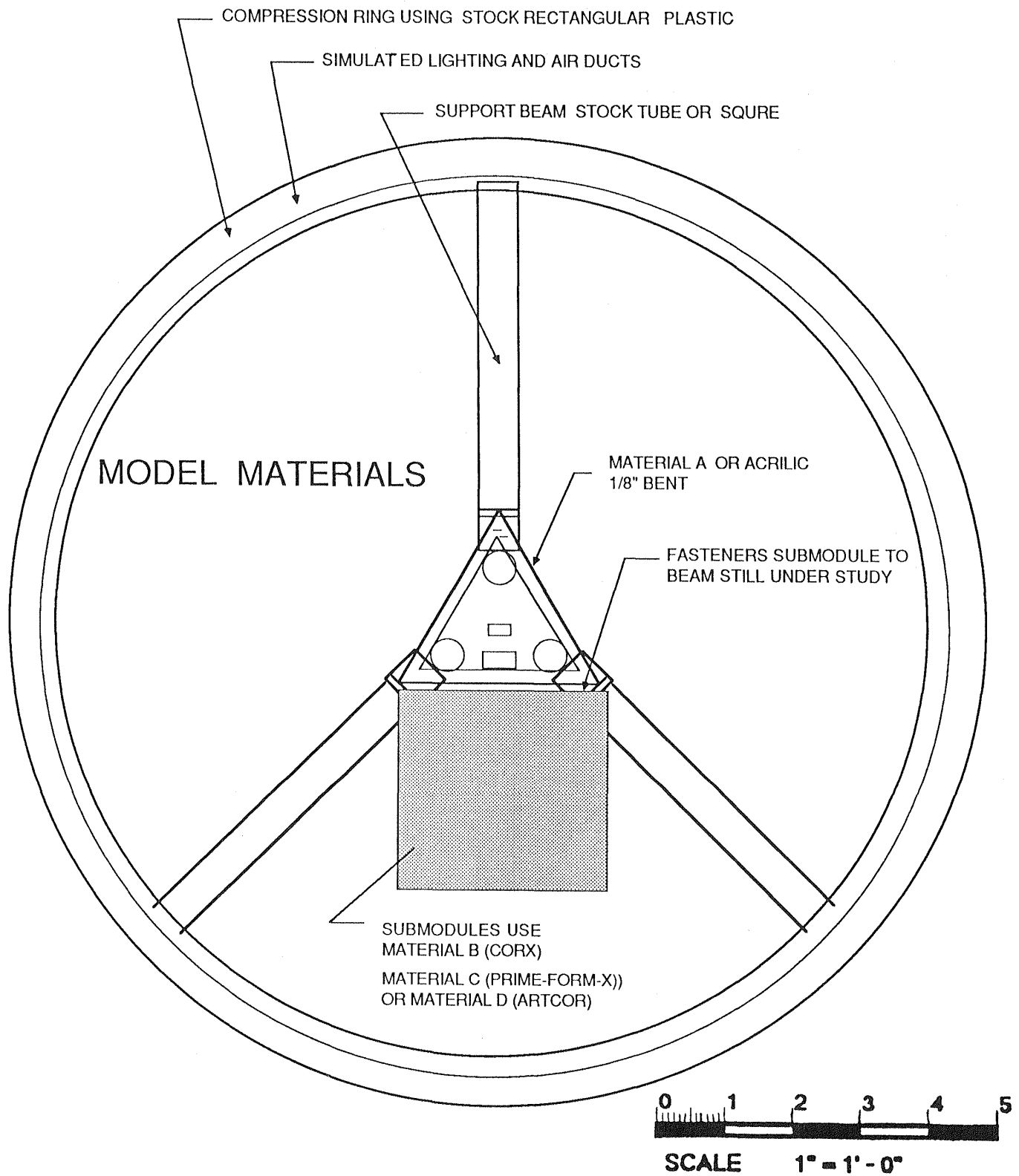

Figure 66 Triangular Beam Model - Model Materials Prelim

COMPARISONS - VOLUME AND PACKING DENSITY

INTERIOR ARRANGEMENT	EQUIPMENT VOLUME	EXPANDED EQUIPMENT VOLUME + (UTILITIES)	PASSAGE WAYS	NEGATIVE VOLUME	NEGATIVE VOL. %	EXP. EQUIP. 140.5 CF
1. TRIANGLE ON CENTER	43	82.5 (4)	15	43	31	59
2. TRIANGLE OFF CENTER	36	86.5 (4)	15	39	28	62
3. SQUARE BM	36	89(3.45)	22.5	29	21	63
4. HEX SMALL	30	60 (4)	7.5	73	52	43
5. HEX LARGE	54	107 (14)	24.9	8.6	6	76
6. H BEAM	63	97 (3.3)	9	34.5	25	69
7. HEX MEDIUM	41	83.3(7.9)	3.3+	57	41	59
SPACELAB* 159.84" ID	57	97.5(19.3)	32	11	8	69
SPACE STA * 166" ID EST	62	77.7(15.7)	42.3	20.5	15	55

* ADJUSTED TO 13'- 4 1/2" OR 160.5 INCH INSIDE DIAMETER
ALL ABOVE BASED ON 140.5 CF INTERIOR VOLUME

Figure 67 Interior Layout Comparisons

GFE MODULE STRAIGHT SECTION

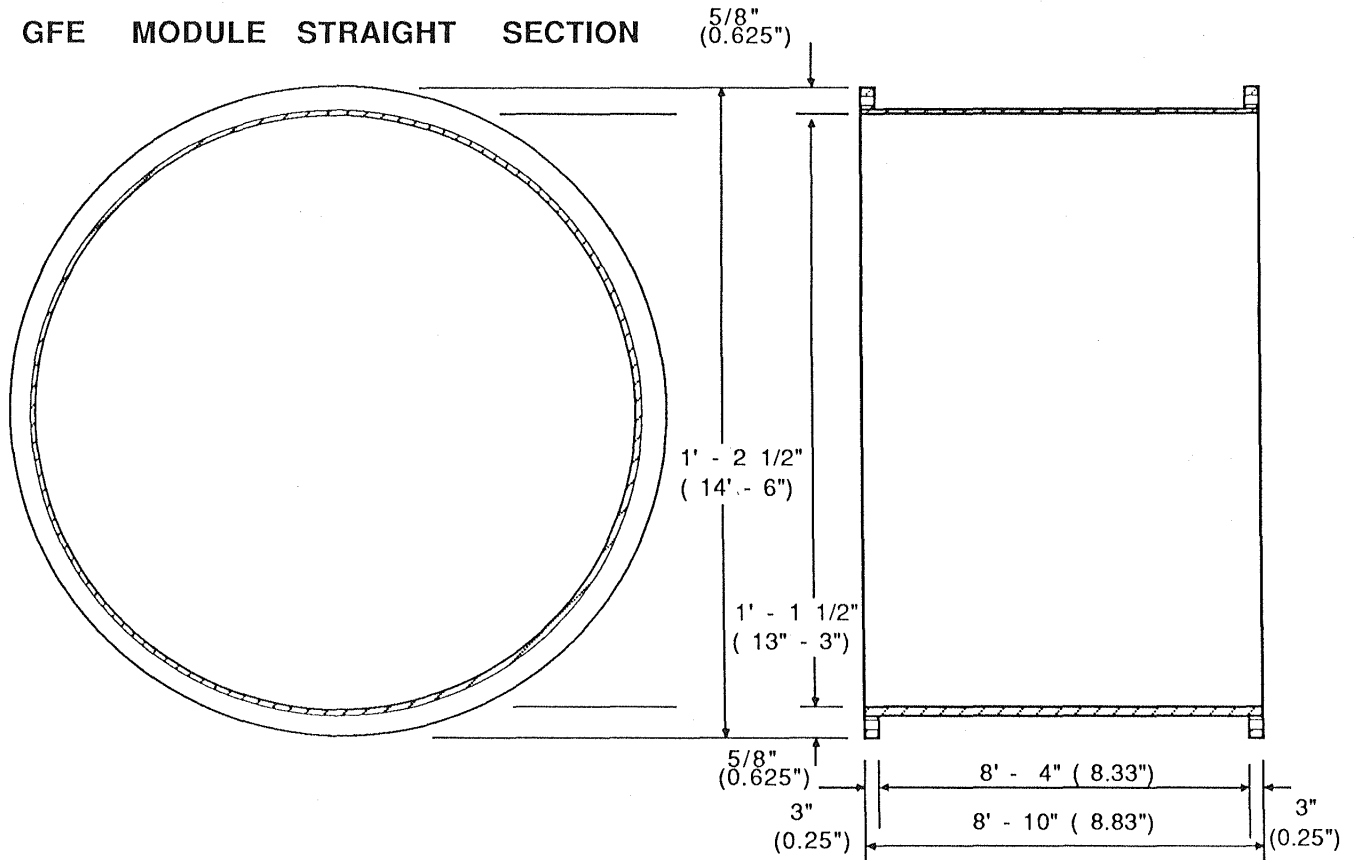

GFE CONICAL END CAP

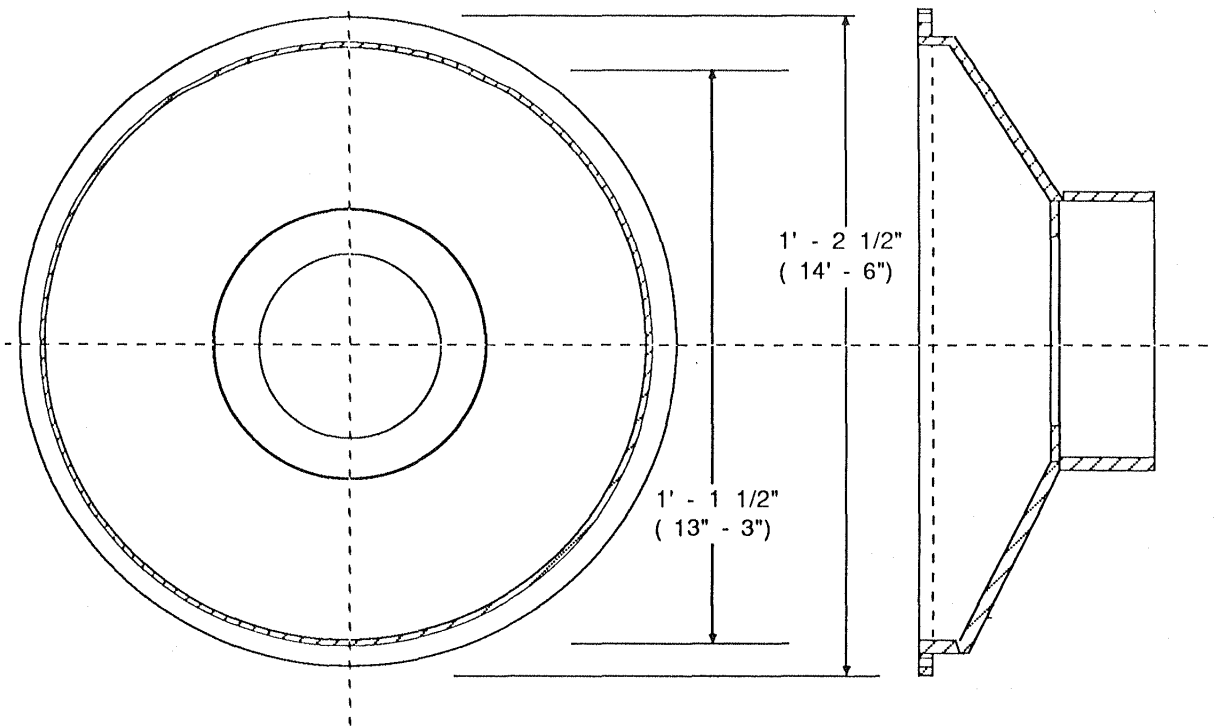

Figure 68 Volume and Packing Details

HUMAN FACTORS/HUMAN PRODUCTIVITY VARIABLES

The issues wrung out and tested by inquiry by design include operations, design and human performance. Each beam type is rated by the author against a matrix of evaluation factors. Figure 69 uses the following numbers for the beam types, and

1. TRIANGULAR BEAM LOCATED ON CENTER OF MODULE
2. TRIANGULAR BEAM LOCATED OFF CENTER
3. SQUARE BEAM ON CENTER
4. HEXAGONAL BEAM - SMALLER THAN 4 FEET
5. HEXAGONAL BEAM - LARGER THAN 4 FEET
6. H BEAM - LOCATED IN THE CENTER
7. HEXAGONAL BEAM - MEDIUM

breaks down the Evaluation Factors suggested in the beginning of the report into four major headings each assumed to have equal weight and scored from 0 to 25. The scoring is heavily weighted toward safety and access to the inner skin, toward human factors and toward life cycle cost and changeout factors. Other individuals would likely have a different view and weighting criteria. The reader is encouraged to set up a criteria for evaluation, add those items important from the reader's perspective and determine the relative score of each of the interior designs. The total of the four is 100 points and the author's breakdown is shown in Figure 69.

TECHNICAL

The technical portion of the total evaluation factor is expected to be user defined, but to contain criteria such as:

- A. Technical Design - 5 total points this subgroup
 1. Weight
 2. Volume
- B. Technical Operation/Performance - 5
- C. Standardization - 5
- D. Ease of Integration and Changeout - 10

EFFICIENCY

The efficiency portion of the total evaluation factor is expected to be user defined and focuses on the long term aspects which usually are difficult in remote locations, but to contain criteria such as:

- A. Volumetric Analysis - 15
 1. Packing Density
 2. Utility Volume
 3. Equipment Volume Capabilty
- B. Frontal Area for Equipment - 5
- C. Life Cycle Consideration and Volume for Growth - 5

**HUMAN FACTORS/
HUMAN PRODUCTIVITY
RATING TABLE**

	1. TRIANGULAR BEAM LOCATED ON CENTER	2. TRIANGULAR BEAM LOCATED OFF CENTER	3. SQUARE BEAM ON CENTER	4. HEXAGONAL BEAM - SMALLER THAN 4 FEET	5. HEXAGONAL BEAM - LARGER THAN 4 FEET	6. H BEAM - LOCATED IN THE CENTER	7. HEXAGONAL BEAM - MEDIUM	8. SPACELAB	9. SPACE STATION
TECHNICAL									
A. Tech Design									
1. Weight - 1	1	1	1	1	1	1	1	1	1
2. Volume - 4	1	3	3	0	4	3	1	3	1
B. Tech Op/Pr - 5	1	1	1	1	4	5	4	3	4
C. Standardization - 5	0	0	0	0	4	5	4	3	4
D. Ease Intgr/On Orbit Chg/Out - 10	9	9	0	9	10	5	7	0	6
EFFICIENCY									
A. Volumetric Analysis									
1. Packing Density - 5	1	2	2	0	5	2	1	2	1
2. Utility Volume - 5	5	5	5	5	0	5	3	0	0
3. Equipment Volume Capabilty - 5	3	4	4	0	5	5	3	3	1
B. Frontal Area for Equipment - 5	5	5	3	4	2	1	4	0	3
C. Life Cycle/Volume Growth - 5	5	5	2	2	2	2	5	2	3
HUMAN ACCEPTANCE									
A. Ergonomics - 2	2	2	0	2	2	0	0	1	2
B. Safety - 2	2	2	2	0	0	0	0	0	0
C. Crew Time/Efficiency - 2	2	2	0	0	0	0	2	2	2
D. Training ease on surface - 2	0	0	0	0	0	0	0	2	1
E. Human Feel-Per Percep -15	15	14	6	6	12	8	10	1	3
F. Crew Traffic - 2	2	2	0	2	2	0	0	1	2
MAINTENANCE									
A. Logistics/Equip Changeout - 10	10	8	1	10	8	2	8	2	4
B. Access to Hull Inspect - 10	10	10	0	6	0	8	10	0	0
C. Repair Sequence/Disrupt/Op - 2	2	2	1	1	1	1	1	0	0
D. Maintenance Required - 2	2	2	0	0	0	0	0	0	0
E. <u>Commonality</u> - 1	1	1	1	1	1	1	1	1	1
TOTAL EVALUATION SCORE	79	79	33	49	63	54	67	26	37
RANK	1	2	8	6	4	5	3	9	7

Figure 69 Evaluation Criteria on Interior Configurations

This factor is expected to strongly reflect the factors which set the Space Station Program apart from previously, relatively short "visits" to space from a permanently manned facility.

HUMAN ACCEPTANCE

The human acceptance portion of the total evaluation factor is expected to be totally a space station user rated factor based on personal perceptions. It contains criteria such as:

- A. Ergonomics - 2
- B. Safety - 2
- C. Crew Time/Efficiency - 2
- D. Training Ease on Surface - 2
- E. Human Feel-Personal Perceptions - 15
- F. Crew Traffic - 2

This component of the total evaluation is meant to be almost totally evaluated by the individuals to actually be on orbit.

MAINTENANCE

The maintenance portion of the total evaluation factor is expected to be rated by the Space Station maintenance staff after the first tour of duty and contains criteria such as:

- A. Logistics and Equipment Changeout Operational Ease - 10
- B. Access to Inner Hull for Inspection, Cleaning and Emergency Situations - 10
- C. Repair Sequence and the Degree it Disrupts Other Operations - 2
- D. Maintenance Required - 2
- E. Commonality of Fittings, Valves, Tools, Consumable Spares - 1

This may be the most important of the evaluation factors, if surface experience is to be believed as an indicator of orbital problems with human productivity in long duration missions.

The exact weighting and breakdown of the general categories is a matter of opinion and every reader will have a different approach to the utilization of the evaluation tool. The value to the industry may be awkward. Before we can develop a more rigorous evaluation criteria and methodology we must first test and try to apply this method.

ISSUES

The issues raised by the beam designs are oppositions or gradients. They include issues which may evolve into factors in future trade studies and the suggested evaluation criteria. They include:

1. Packing Densities vs Circulation
2. Packing Densities vs Perceived Spaciousness
3. Symmetry - Equipotentiality of Utilities Interconnects
4. Asymmetry - Diversity of Functional Allocations
5. Efficiency of Packing/Standardization vs Flexibility/Diversity
6. Standardization of Utility Interfaces vs Diversity of Accommodation Needs

7. Standardization of Structural Interfaces vs Diversity of Modular Packing
8. Composition of Interior Volume as a Space for Living as a PLACE vs Residual "Negative" Volume

The central beam designs provided seven opportunities to the theoretical aspects of interaction.

INTERACTION THEORY

DESIGN CONCEPT FOR TESTING

- | | |
|---|--|
| 1. Symmetric core with 120 degree brace at mid points - minimal central beam - triangular is most surface area to volume - relate to circle section well. | 1. Central Triangular Beam |
| 2. Moving the core of center beam yields greater cross sectional area and diversity of functional allocations. | 2. Triangular Beam Off Center |
| 3. Most perfectly space filling beam allows alignment of opposite sides - 2 axis symmetry. | 3. Square Beam On Center |
| 4. Structural Rationalization and increased/ maximized surface area from square - fold in mounting surface - allow plug-ins. | 4. H or Wide Flange Beam (Compact Section) |
| 5. Beam is essentially a matrix or web of utilities/sub cores - can be spread apart for better axis, more surface. | 5. Small Hexagonal Beam |
| 6. Utility core can develop into parallel circulation - offer spatial definition. | 6. Large Hexagonal Beam |
| 7. Utility core is medium size and could provide three utility cores and a circulation volume with access on both sides of the equipment modules. | 7. Medium Hexagonal Beam |

OBSERVATIONS

The following observations are offered from the research.

1. Symmetry - Although symmetry is generally assumed for the central beam, in fact the distribution of functions around the utility core shows that true flexibility is sometimes opposed to symmetry. The utilities available to each sub-module footprint aren't the same and may not be required to be the same.
2. Asymmetry - Pressure for accommodations of greater diversity of functions around the utility core tends to push the beam off center or break up the volume - "half hex"

3. Flexibility - Often assumed to imply to equipment functionality around a symmetric core, but equipment space within the module should force flexible spatial accommodations. The entire module may change interior configurations much the way a building or lab on Earth changes in its design life.

4. Negative Space/Spatial Composition - Space around equipment is often assumed to be residual only - to allow servicing or other anthropometric envelopes, but to create a true habitable sense of place, the empty volume must be sculptured with equal care as solid packing of equipment. Solid and open volumes are of equal importance.

5. Spatial Composition is neglected in Spacelab type floor/ceiling studies because:

- a. Floor or ceiling, by its mere presence is assumed to create a "place."
- b. All residual volume occurs on the interior core, but in most concepts it is just residual negative volume and not a designed habitable space.

6. Flexibility vs Efficiency of Volumetric Packing - There seems to be an inverse relationship between flexible/readily usable packaging such as the 3' x 3' x 7' modules vs. the enforced stuffing of volume with wall curvature matching racks, i.e. on Spacelab although the racks outer casings occupy a consistent volume, behind the front face, there is an inconsistent degree of packing and true spatial utilization. Perimeter packing of space station would yield a similar result. The illusion of packing efficiency. The Central Beam allows the diversity of packing shapes and sizes, without racks to enhance - maximize perceived space by eliminating hidden residual space. Figure 53 depicts the point.

The hidden residual space in the perimeter packing of the Spacelab Module can be seen in Figure 70. The hidden residual packing can also be seen in the four point stand-off system in the same figure. The central beam eliminates hidden residual space as can be seen in the figure.

The "Center Aisle" derived from perimeter packing does not accommodate special purpose or dedicated/proprietary work stations and work environment volumes, simply because it cannot mold a piece of space to create a place. The arbitrary division of the center aisle artificially divides open residual volume in a way unrelated to work. See Figure 70.

CONCLUSIONS

1. The "Central Beam" concept in general and specific derivations of the central beam has some advantages in the human factors, utilities, volume utilization, logistics, equipment accessibility and minimum negative interior volume.
2. Utilities will emerge as a critical part of the interior design.
3. Quick access to the interior module skin is a safety issue and in emergency situations rapid access to repair could be extremely important.
4. The computer generated human form can be useful in early studies. Computer software exists to take the computer generated form into 3 dimension and color. This level of detailed computer graphics (one level beyond those used in this report) could effectively research the microgravity aspects of human interface which are difficult to simulate on the surface one gravity environment.

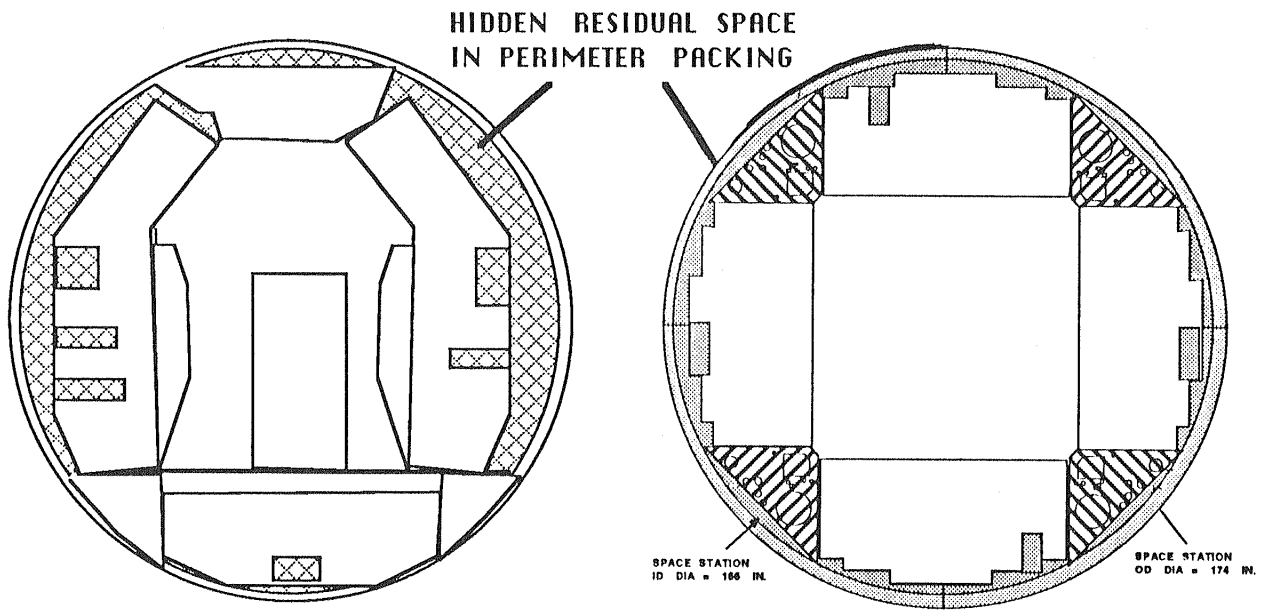

SPACELAB

FOUR-STAND OFF

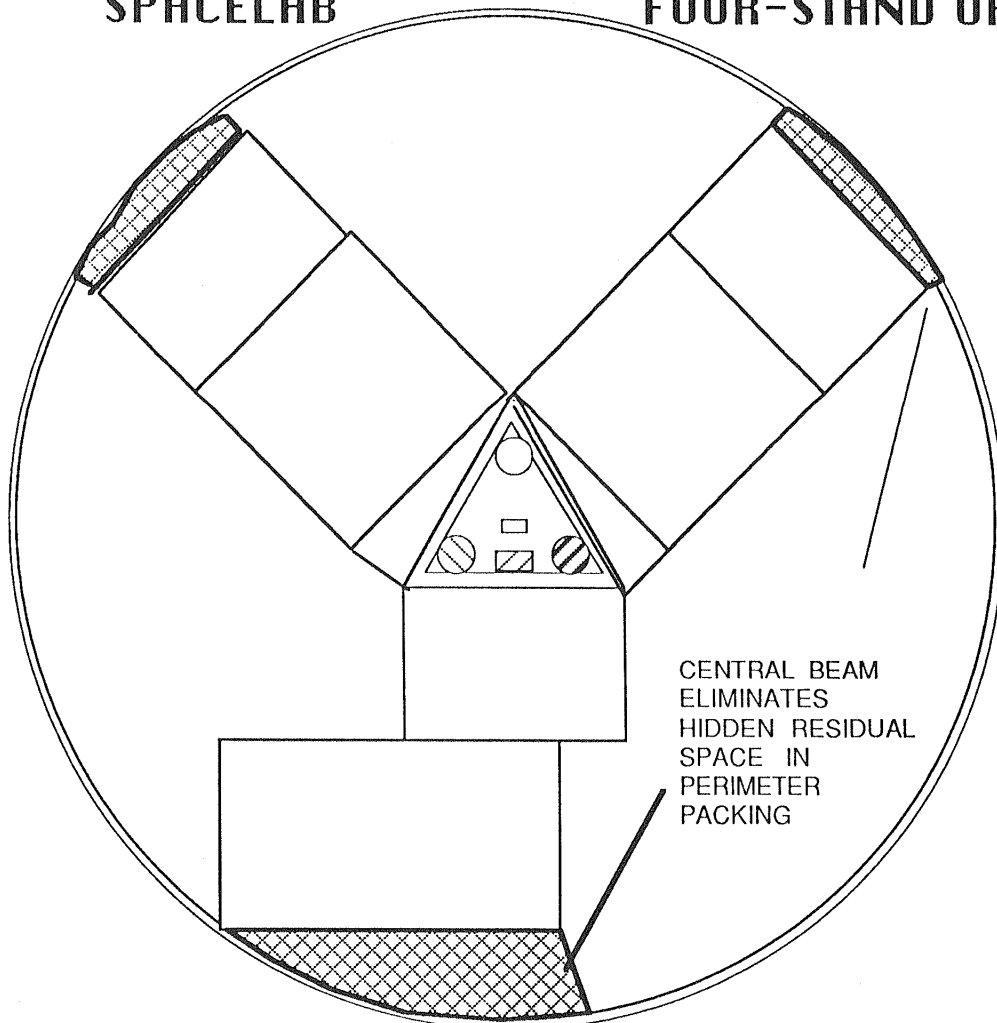

Figure 70 Comparison of Negative Volume

5. Commercial customers will value proprietary separate work volumes more than is now envisioned. The interior arrangement which provides the most effective proprietary volumes in the lab module will stimulate the commercial sector participation.
6. The NASA furnished plastic scale model shell created an effective method of studying the interior of a confined volume. The node and module interface can be studied in the same way.
7. Individual submodules can be later flight tested in the microgravity environment by several methods including components in middeck lockers, Spacelab and SPACEHAB volumes in the Space Shuttle. The entire common module is too large to test in advance in orbit or to adequately simulate on the surface. Adequate models or enhanced computer generated 3D humans may be the only method to check the entire volume prior to deployment in orbit.
8. Effective equipment surface front area or useful wall area is an effective evaluation criteria in a microgravity environment, just like useful square footage is an evaluation criteria in Earth buildings.
9. The personal workstation revolution will emerge as a major human productivity tool of the 1990's as massive storage and other enhancements are added to existing commercial products. Combining artificial intelligence and robotics with the workstation research could have additional impact on the station and the Earth based spinoffs. NASA could lead the research in the man/machine interface, ergonomics, new product testing and human factors in this field and insure the space station will have a good flow of hardware for station applications. The impact of NASA research could have a dramatic effect on the human productivity movement on Earth and in orbit.

RECOMMENDATIONS

1. Expand the anthropometrics from Brand Griffin's work into a 5%, 50% and 95% percentile form for male and female human forms for use on the computer and graphics. The research should explore the use of link type depictions capable of use in premock-up type hardware designs and capable of being offered to the industry in some useful form. Potentially, a computer disk could be created with the user modified forms in a graphics package. Computer graphics are emerging for full color anthropometrics which could provide significant breakthroughs in Space Human Factors research.
2. Evaluate and isolate the one or two commercial scenarios in a 90 day context which utilize the Space Station and follow the individuals and organizations through the beam types of greatest value and interface with a full common module. When this "Full Immersion" Technique was used in other situations such as Alaska planning it produced remarkable results and many surprises.
3. Expand and refine the technical data available on the utility requirements, because these details will probably drive the beam configuration and the long term maintenance considerations as well as some of the logistics considerations. Develop a new rule of thumb criteria and a list of design guidelines/procedures for microgravity using existing utility design principles.
4. Determine an accepted General Evaluation Factor along the lines suggested to evaluate interior hardware and volumes on paper prior to full scale testing on the Earth and later in orbit. The proposed Evaluation Factor is only a crude beginning and subject to revision by

many organizations. The emphasis on the human aspects is important, but unfortunately the critics to this focus will only realize it after the station is in operation.

5. Determine the best method to test the various interior volumes in a manner which best compensates for the microgravity considerations of orbit, possibly a shallow neutral buoyancy tank within the NASA Center capable of interior volume underwater research with light air lines and not with heavy air tanks.

6. Create a full scale mock-up of the Personal Engineering Workstation and research its value to the Space Station Project as an orbital desk, communications enclosure, secure enclosure, private volume, research monitoring device, duplicate communications enclosure at the surface team's location and other yet to be determined uses.

7. Explore the commercial opportunities for funding research in the Engineering Workstation for several reasons including difficulty in getting funding within the NASA Space Station budget cycle, the potential exists for utilization on Space Station and in surface applications related to same and the apparent billion dollar market shaping up in the commercial personal computer market. This avenue of research could place NASA-Ames in a unique position with respect to the transfer of NASA Human Factors research to society through an emerging human productivity hardware with surface and orbital applications.

One avenue of research beyond the current scope of this contract would create a human form for a variety of percentile male and female forms. This type of additional focusing on the anthropometrics is beyond the scope or budget of this contract, but will be suggested as an avenue of future study and potentially of interest to the Space Station industry.

APPENDIXES

Appendix A contains the Index Sheets for the drawings created to date.

Appendix B contains magnetic disk version of report information.

NASA-AMES SPACE STATION MODEL STUDY

INDEX OF DRAWINGS

31797 - T 100 ORIGINAL TRIANGULAR BEAM RENDERING

- T 102 GOAL AND PLAN
- T 103 ORIGINAL CONCEPT DETAILS - 1984 CONTRACT
- T 104 RELATIVE UTILITY VOLUME
- T 105 NASA-AMES GFE MODELS
- T 106 HATCH - 50 INCH DIAMETER

- T 140 TRIANGULAR BEAM UTILITIES
- T 141 MAXIMUM HATCH PASS THROUGH
- T 142 BOXED HATCH PASS THROUGH
- T 143 UTILITY PLANNING - I
- T 144 UTILITY PLANNING - II

- T 160 BASIC CONCEPT STRUCTURE
- T 161 SUPPORT STRUCTURE DETAILS
- T 162 BEAM SUBMODULE INTERFACES
- T 163 COMMON MODULE WITH ELLIPSE CAPS
- T 164 MODEL MATERIALS

- T 201 BEAM TYPE BREAKDOWN
- T 202 BEAM SECTIONS AND DIMENSIONS
- T 203 BEAM LOCATION - CENTER
- T 204 CENTER - SUBMODULE OPTIONS
- T 205 NON EQUALATERAL BEAM
- T 206 BEAM LOCATION - OFF CENTER
- T 207 BEAM - OFF CENTER OPTIONS S/L

- T 290 UTILITIES - SUBMODULE
- T 291 SUBMODULE - ROUNDED CORNER
- T 292 SUBMODULE - CLIPPED CORNER

tai TAYLOR & ASSOCIATES, INC./P.O. BOX 1847
WRIGHTWOOD, CA 92687 PHONE 619-240-0202

SPACE STATION MODEL STUDY			
DATE	APPROVED BY	DATE	BY
29 JUL 85	THOMAS C. TAYLOR <i>Thomas Taylor</i>		YCT
NASA-AMES		CONTRACT 31797	

NASA - AMES SPACE
STATION MODEL STUDY

INDEX OF DRAWINGS

31797 - T 145 PARTS-TRIBEAM ON CENTER
T 146 FAB-TRIBEAM
T 147 MODEL-TRIBEAM
T 148 DOUBLE/HALF SUBMODULES

T 150 TRIBEAM ON CENTER
T 151 ON CENTER FAB
T 152 ON CENTER EXAMPLES
T 153 ON CENTER COMBINATIONS

T 742 SQUARE BEAM-OPTION A
T 743 SQUARE BEAM-FAB
T 744 SQUARE BEAM-OPTION B-PARTS
T 745 SQUARE BEAM-LAYOUT

T 753 HEX PARTS LIST
T 754 HEX BEAM

T 763 CENTRAL H BEAM

T 770 T BEAM

T 300 GOAL-ENG. WORKSTATION
T 301 WORKSTATION METHOD
T 302 WORKSTATION EVOLUTION
T 303 EVOLUTION-WORKSTATION
T 304 TOP/SIDE DETAILS
T 305 USER DEFINED EQUIPMENT

T 350 LAUNCH CONFIGURATION

 TAYLOR & ASSOCIATES, INC./P.O. BOX 1847
WRIGHTWOOD, GA 32097 PHONE 910-240-0808

SPACE STATION MODEL STUDY		
DATE 19 SEP 85	APPROVED BY THOMAS C. TAYLOR	DESIGNED BY TGT
NASA-AMES CONTRACT 31797		

NASA - AMES SPACE STATION MODEL STUDY

INDEX OF DRAWINGS

31797 - T 010 TITLE SHEET
T 021 INDEX SEPT
T 120 ANATOMICAL SIDE
T 121 SIDE ARM MOVEMENTS
T 122 SIDE LEG MOVEMENTS
T 128 ANATOMICAL COMPUTER
T 129 COMPUTER ASSEMBLED MODE
T 130 ANATOMICAL FRONT
T 135 ANATOMICAL TOP
T 610 SLEEP QTRS-TRIANGULAR
T 611 CREW GALLEY-TRIANGULAR
T 612 GALLEY-OFF CENTER
T 613 EQUIPMENT SIZING
T 614 INTEGRATED HAB INTERIOR
T 615 HYGIENE SECTION
T 616 SPECIALIZED HIGH DENSITY
T 710 CENTRAL BEAM VARIATIONS
T 720 TRIANGULAR-HIGH DENSITY
T 721 TRIANGULAR PACKING
T 722 TRIANGULAR STACKED
T 730 EXPANDED INTERIOR DETIALS
T 740 SQUARE BEAM CONCEPT
T 741 WORK STATION - SQUARE
T 750 HEXAGONAL BEAM
T 751 HEX HIGH DENSITY
T 752 HEX EXTERIOR CONCEPT
T 760 H BEAM CONCEPT
T 761 H BEAM DENSE PACK
T 762 H BM WORKSTATION
T 980 PROJECT SCHEDULE



TAYLOR & ASSOCIATES, INC./P.O. BOX 1647
WRIGHTWOOD, CA 92597 PHONE 619-640-6888

SPACE STATION MODEL STUDY		
DATE	APPROVED BY	REVISED BY
31 AUG 88	ROBERT C. TAYLOR	REVISED
INDEX SEPT		
NASA-AMES CONTRACT 31797		PROJECT NUMBER T 021 A

APPENDIX B

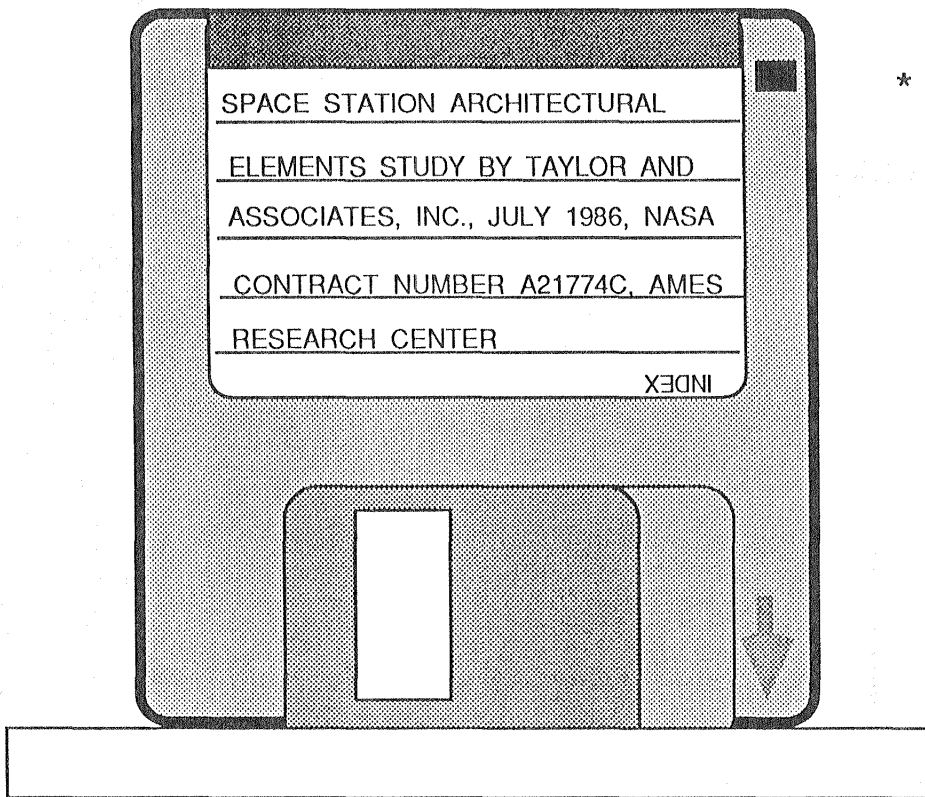

* The NASA published report will be available in mid 1987 through normal government publication sources. Prepublication copies of the report are available in magnetic disk and bound hard copy form. This report is available in both report forms from the following locations.

NASA - Ames Research Center
Space Human Factors Office
Attn: Marc C. Cohen, Mail Code LHS 239-2
Moffett Field, CA 94035

Taylor and Associates, Inc.
Attn: Pub A21774C
P.O.Box 1547
Wrightwood, CA 92397
Phone 619-249-6882

The magnetic version was created on a Mac 512 computer using Microsoft Word, MacDraw, MacDraft, Easy 3D and MacPaint. Some human figures were Thunderscanned from Brand Griffin's work in 1978 and converted to MacPaint for additional enhancement. The images using each software are grouped for easy access by the user. The cost for the hard copy is \$ 25 and the disc version is \$ 18.

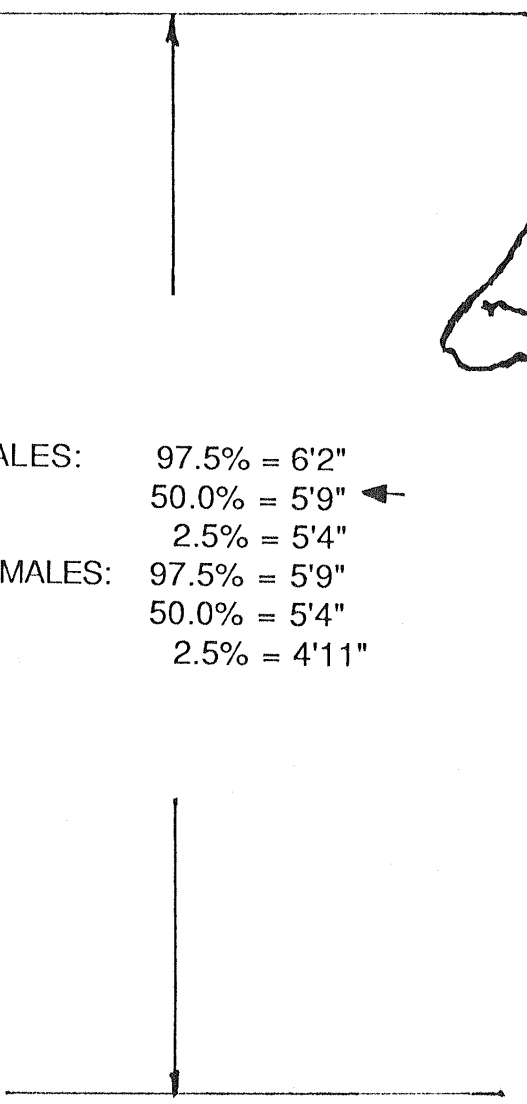
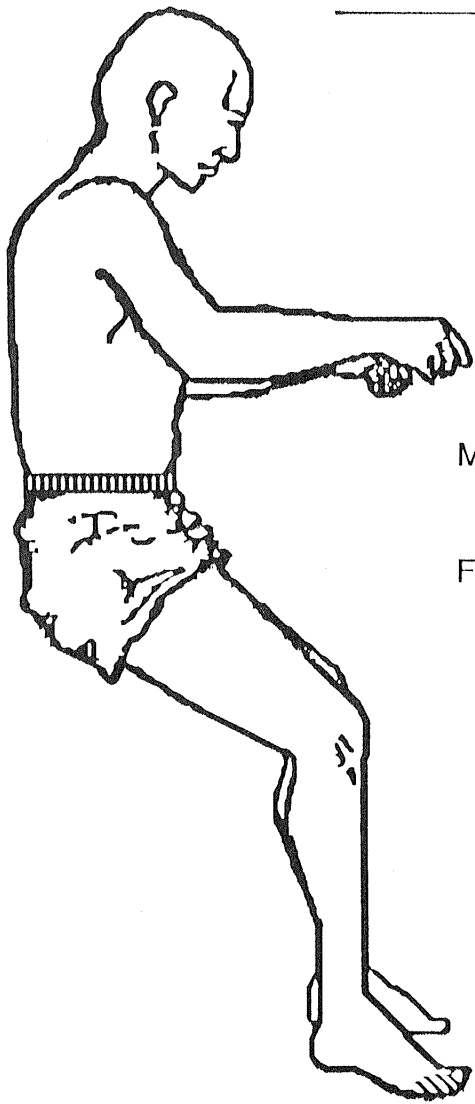

MALES: 97.5% = 6'2"
50.0% = 5'9" ←
2.5% = 5'4"
FEMALES: 97.5% = 5'9"
50.0% = 5'4"
2.5% = 4'11"

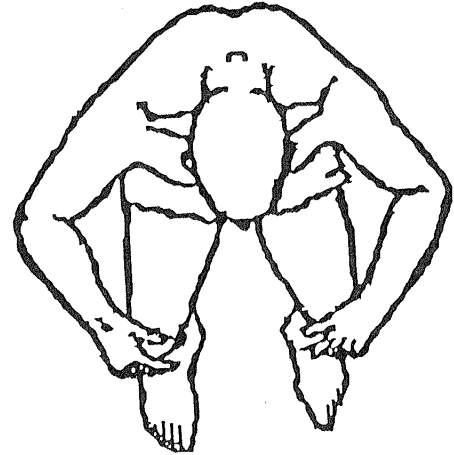
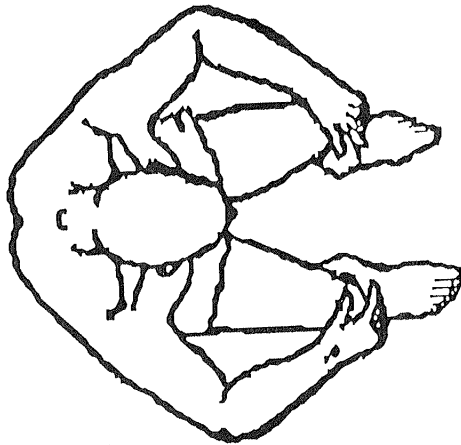

SCALE 1" = 1' - 0"

REFERENCES

1. Griffin, B., Design Guide: The Influence of Zero-G and Acceleration on the Human Factors of Spacecraft Design, NASA-JSC 14581, August 1978.
2. Taylor, T.C., Spencer, J.S. and Rocha, C.J., Space Station Architectural Elements and Issues Definition Study, NASA Contractor Report C-3941, March 1985.
3. Taylor, T.C., A Commercial Construction Base Using the External Tank, 2nd AIAA Conference on Large Space Platforms, Paper #AIAA-81-0460, Feb.2-4, 1981, San Diego, CA.
4. Taylor, T.C., Personal observations in Alaskan remote construction camps, Prudhoe Bay, Alaska, 1975-79, Report A-7 by author.
5. NASA, Space Station Reference Configuration Description, NASA-JSC, JSC-19989, August 1984.

1. Report No. NASA CR-4027		2. Government Accession No.		3. Recipient's Catalog No.	
4. Title and Subtitle Space Station Architectural Elements Model Study				5. Report Date January 1987	
				6. Performing Organization Code	
7. Author(s) T. C. Taylor, J. S. Spencer, C. J. Rocha, E. Khan, E. Cliffton, and C. Carr				8. Performing Organization Report No.	
				10. Work Unit No.	
9. Performing Organization Name and Address Taylor and Associates, Inc. P.O. Box 1547 Wrightwood, CA 92397				11. Contract or Grant No. A211774C	
				13. Type of Report and Period Covered Contractor Report	
12. Sponsoring Agency Name and Address National Aeronautics and Space Administration Washington, DC 20546				14. Sponsoring Agency Code 506-57	
15. Supplementary Notes Point of Contact Marc M. Cohen, NASA Ames Research Center, Mail Code LHS 239-2					
16. Abstract A study was conducted to develop, amplify, refine and resolve several of the ideas presented in a previous contract, NASA CR 3941. The worksphere, a user controlled computer workstation enclosure, was expanded in scope to an Engineering Workstation suitable for use on the Space Station as a crewmember desk in orbit. The concept was also explored as a module control station capable of enclosing enough equipment to control the station from each module. The concept has commercial potential for the Space Station and surface workstation applications. The computer revolution in America is expected to evolve into a significant personal workstation market with each productive individual of the economy requiring a unit capable of user specific definition. This is expected to be duplicated at Space Station for each crewmember. The Central Triangular Beam interior configuration was expanded and refined to seven different beam configurations. These included Triangular On Center, Triangular Off Center, Square, Hexagonal Small, Hexagonal Medium, Hexagonal Large and the "H" Beam. Each was explored with some considerations to the utilities and a suggested evaluation factor methodology was presented. Scale models of each concept were made. The models were helpful in researching the seven beam configurations and determining the negative residual(unused) volume of each configuration. The Final Report contained photographs and the models were delivered to NASA. The author proposed a flexible Hardware Evaluation Factor Concept which could be helpful in evaluating interior space volumes from a human factors point of view. A magnetic version with all the graphics is available from the author or the technical monitor.					
17. Key Words (Suggested by Author(s)) Space station Human productivity Interior innovation Space commercialization			18. Distribution Statement Unclassified - Unlimited Subject Category 05		
19. Security Classif. (of this report) Unclassified		20. Security Classif. (of this page) Unclassified		21. No. of Pages 140	22. Price* A07

*For sale by the National Technical Information Service, Springfield, Virginia 22161

NASA-Langley, 1987

End of Document