

NASA Technical Memorandum 100914

Progress in InP Solar Cell Research

(NASA-TM-100914) PROGRESS IN InP SOLAR CELL
RESEARCH (NASA) 16 p CSCI 1CA

N88-24870

Unclas
G3/33 0148162

Irving Weinberg and David J. Brinker
Lewis Research Center
Cleveland, Ohio

Prepared for the
23rd Intersociety Energy Conversion Engineering Conference
cosponsored by the ASME, AIAA, ANS, SAE, IEEE, ACS, and AIChE
Denver, Colorado, July 31—August 5, 1988

The NASA logo, consisting of the word "NASA" in a bold, sans-serif font.

PROGRESS IN InP SOLAR CELL RESEARCH

Irving Weinberg and David J. Brinker
National Aeronautics and Space Administration
Lewis Research Center
Cleveland, Ohio 44135

SUMMARY

Progress, during the past year, in InP solar cell research is reviewed. Small area cells with AMO, total area efficiencies of 18.8 percent were produced by OMCVD and Ion-Implantation. Larger area cells (2 cm² and 4 cm²) were processed on a production basis. One thousand of the 2 cm² cells will be used to supply power to a small piggyback lunar orbiter scheduled for launch in February 1990. Laboratory tests of ITO/InP cells, under 10 MeV proton irradiation, indicate radiation resistance comparable to InP n/p homojunction cells. Computer modelling studies indicate that, for identical geometries and dopant concentrations, InP solar cells are significantly more radiation resistant than GaAs under 1 MeV electron irradiation. Additional computer modelling calculations were used to produce rectangular and circular InP concentrator cell designs for both the low concentration SLATS and higher concentration Cassegrain Concentrators.

INTRODUCTION

Indium phosphide solar cells are excellent candidates for use in the space radiation environment. This follows from their significantly increased radiation resistance when compared to gallium arsenide and silicon (ref. 1). In addition, InP cells have been observed to anneal at room temperature under dark conditions and under the influence of incident light (refs. 2 and 3). Furthermore, AMO total area efficiencies of over 20 percent have been predicted using a conservative model (ref. 4). For these reasons, the NASA Lewis Research Center has been conducting a program aimed at developing high efficiency, radiation resistant InP solar cells.

CELL PERFORMANCE

Interest in InP solar cells was stimulated by the demonstration, in 1984 that relatively high efficiency n/p InP solar cells with excellent radiation resistance could be processed by a relatively simple, closed tube diffusion process (refs. 5 and 6). Progress in achieving high efficiencies, dating from that time, is shown in figure 1. All data shown are air mass zero, total area measurements obtained at NASA Lewis. The highest AMO efficiency (18.8 percent) was obtained by a combination of organometallic chemical vapor deposition (OMCVD) and ion-implantation (ref. 7). A zinc doped p-type layer, 3- μ m thick, was epitaxially deposited onto a heavily doped p-type substrate and the p-n junction formed by ion-implantation of silicon. AMO parameters for this cell are shown in table I where it is noted that the total cell area was 0.25 cm². In fact, for reasons of economy, all of the cells shown in figure 1 are of similar small areas. Recently however, larger area (4 cm²) cells have been produced using a closed tube diffusion process (refs. 8 and 9). For these cells

In₂S₃ was used as a diffusion source to produce the sulphur doped n-region into a zinc doped p-type substrate doped to $2 \times 10^{16}/\text{cm}^3$ (table I) (ref. 8). These cells were produced on a production basis to yield 1cm by 2cm cells in addition to the 4 cm² cells. These 2 cm² cells are intended for use on the Muses-A spacecraft to be launched in February 1990 (ref. 10). A cutaway view of the spacecraft is shown in figure 2. The larger spacecraft will perform periodic lunar swingbys. At the first swingby the small piggyback lunar orbiter will be injected into an orbit around the moon. Power for the lunar orbiter will be generated by approximately 1000 2 cm² InP cells with 50- μm cover glass. The orbiter is spin stabilized with the InP cells generating about 10 W of power (ref. 10). The larger satellite is powered by silicon solar cells. Since the moon lacks a magnetic field, the lunar orbiter will not be subjected to a severe ambient radiation environment. In fact, radiation from solar flares will present the severest radiation hazard to the small lunar orbiter. Thus, rather than being a severe test of the behavior of InP cells in a strong space radiation environment, the forthcoming lunar orbiter will serve mainly as a vehicle for space qualification of these cells.

RADIATION DAMAGE

Despite the low radiation level encountered in lunar orbit it is necessary to conduct laboratory tests on the large area InP solar cells. The results of 10 MeV proton irradiations are shown in figure 3 where the 2 cm² cells typical of those used on the lunar orbiter, are compared to n/p GaAs and small area, diffused junction n/p InP cells. Pre-irradiation parameters for these cells are shown in table II. The 2 cm² InP cells outperform the smaller area InP cells at the lower fluences but fall off at the higher fluences. Both InP cells exhibit radiation resistance superior to the GaAs cell. With respect to the behavior at high fluence it is noted that the larger area InP cell has a junction depth between 0.2 and 0.3 μm (ref. 8), while the junction depth for the smaller area cell is well under 0.1 μm (ref. 11). Dependence of radiation resistance on junction depth has been previously noted for GaAs where a decrease in junction depth was observed to accompany increased radiation resistance (ref. 12). In the absence of similar data for InP, it is speculated that the fall off at higher fluences may be due to the cell's relatively large junction depth. On the other hand, the increased radiation resistance observed at lower fluence may possibly be due to better substrate quality in the larger area cell. Obviously additional work is required to place these speculations on a firmer basis.

Indium tin oxide/indium phosphide (ITO/InP) solar cells present a lower cost processing alternative to the more common n/p homojunction cells. Previous experience with silicon solar cells, in which an oxide was an active cell component, led to the strong possibility that radiation induced degradation in the oxide was a significant factor in cell degradation (ref. 13). Thus it is relevant to assess the performance of ITO/InP cells in a radiation environment rather than taking it for granted that their radiation resistance will be similar to that observed for the n/p homojunction cells. The results of such irradiations are shown in figure 4, while pre-irradiation cell parameters are listed in table II (ref. 14). The figure indicates that the present ITO/InP cells have radiation resistance, under 10 MeV proton irradiations, which is comparable to that of the n/p homojunction cells. The present ITO/InP cells, supplied by Dr. T.J. Coutts of the Solar Energy Research Institute, were processed by D.C. magnetron sputtering of ITO onto zinc doped p-type InP whose

dopant concentration was $3 \times 10^{16}/\text{cm}^3$. Examination of the ITO/InP interface by Raman spectroscopy and ellipsometry indicates that the cell configuration is most probably that of a semiconductor-insulator-semiconductor (S-I-S), the insulator being amorphous InP (ref. 15).

THEORY

Comparison of InP and GaAs cells, under laboratory irradiations, have employed cells with widely different pre-irradiation parameters. For example; the n/p GaAs cell of figures 3 and 4 has a base dopant concentration which is an order of magnitude greater than that of the n/p InP cells. Previous comparisons, under 1 MeV electron irradiation, have used p/n GaAs cells with an AlGaAs window for comparison with n/p InP cells (fig. 5, ref. 1). In this latter case, the base dopant concentration of the GaAs cell was again an order of magnitude greater than that of the InP cell. In order to compare these cells on an equal basis, a computer calculation was performed using a previously published computer model (refs. 4 and 16). The parameters chosen for comparing both n/p cells are shown in table III. Using these parameters an AMO efficiency of 20.4 percent is predicted for InP while 21.5 percent is predicted for GaAs (ref. 16). However, by reducing the emitter width to 250 to 300 Å, front contact grid shadowing to 4 percent and by use of an optimized two layer AR coating, the optimum efficiency is 21.5 percent for InP and ~22.5 percent for GaAs (ref. 16).

Because of carrier removal effects, it was necessary to use lifetime damage coefficients, K_{τ} , to compute the degradation according to the usual formula,

$$1/\tau = 1/\tau_0 + K \phi \quad (1)$$

where τ is minority carrier lifetime in the base at the 1 MeV electron fluence ϕ and τ_0 is pre-irradiation lifetime. The plot used to obtain K_{τ} for InP is shown in figure 6 a similar plot being used for GaAs. From these data it is found the $K_{\tau} = 1.3 \times 10^{-6} \text{ cm}^2/\text{sec}$ for InP while for GaAs $K_{\tau} = 3.1 \times 10^{-5}$. The computed results for identical cell configurations and doping densities show that the calculated performance of InP is superior to that of GaAs under 1 MeV electron irradiations (fig. 7). It was also concluded that the superior radiation resistance in this case was not due to the higher absorption coefficient on InP but was due to the intrinsic nature of the defects in these two cell types. In this connection, Yamaguchi has tentatively concluded that "the radiation properties of the InP cells was attributable to room temperature and light enhanced annealing phenomena of the major defect centers in InP. The radiation resistance of InP was associated with the lower migration energy of indium and phosphorus displaced atoms in InP compared with those of the Ga- or As displaced atoms in GaAs (ref. 17)."

The model used in the previous case was also used to design and compute the performance of InP cells under concentration at elevated temperatures (refs. 4 and 18). The geometry of a circular cell, for the cassegranian concentrator (ref. 19) and a rectangular cell for the SLATS concentrator (ref. 20) are shown in figures 8 and 9. Cell parameters are shown in tables IV and V. Computed temperature and concentration dependencies of cell efficiencies are shown in figures 10 and 11. A summary of cell parameters at

20 and 100X and at 80 °C is shown in table VI. It is noted that a more comprehensive computer model using a multilayer antireflection coating is being developed and is expected to add at least 1 percent to the efficiencies shown in table VI (ref. 21).

CONCLUSION

Achievement of AMO efficiencies approaching 19 percent makes the ultimate goal (>21 percent) appear attainable. Although the present highest efficiency cells are relatively small, it should be recalled that, for GaAs, efficiencies over 18 percent were first reported, in 1972, for cells whose area was considerably smaller than the present small area cells (ref. 22). The latter cells are of adequate size for concentrator applications such as in the miniature cassegranian concentrator (ref. 19). However, much larger areas are required for planar arrays. The present larger area InP cells, with moderately high efficiencies, are a first step in this direction. However, the method used to produce these larger area cells, i.e. diffusion into a thick Czochralski grown wafer, has inherent limitations. For example, it is noted from table I that the cells produced by OMCVD have much higher open circuit voltages. This is believed to be due principally to the absence of a back surface field in larger cells. This deficiency is inherent in the methodology used to produce these cells (ref. 8). In addition to its flexibility, the use of an epitaxial growth method usually results in a cell base which has less defects than a base consisting solely of a Czochralski grown wafer. Thus it is anticipated that the highest efficiency large area InP cells would ultimately be produced by an epitaxial technique. Aside from this there remains the question of cost and the ability to produce useable large quantities of these cells. The present substrate costs are high but the cost should be reduced when the cells are produced in large quantities. However, a more attractive cost reduction alternative lies in the use of heteroepitaxial growth on cheaper, sturdier substrates. Another alternative for cost reduction lies in the use of techniques, such as the CLEFT process, in which the Czochralski grown substrate is reusable (ref. 23). With respect to quantity production, the example of the cells intended for the small lunar satellite indicate that, if a demand exists, the cells, although presently of moderately high efficiencies, can be produce in relatively large quantities (ref. 8). However, for quantity production of large area, higher efficiency cells, epitaxial growth appears to be the method having the greater possibility of success.

REFERENCES

1. Weinberg, I., Swartz, C.K., Hart, R.E. Jr., and Statler, R.L., "Radiation and Temperature Effects in Gallium Arsenide, Indium Phosphide, and Silicon Solar Cells," Proceedings 19th Photovoltaic Specialists Conference-1987, IEEE, Piscataway, NJ, 1987, pp. 548-557.
2. Yamaguchi, M., Itoh, Y., and Ando, K., "Room-Temperature Annealing of Radiation-Induced Defects in InP Solar Cells," Applied Physics Letters, Vol 45, No. 11, Dec. 1, 1984, pp. 1206-1208.
3. Ando, K., and Yamaguchi, M., "Radiation Resistance of InP Solar Cells Under Light Illumination," Applied Physics Letters, Vol. 47, No. 8, Oct. 15, 1985, pp. 846-848.
4. Goradia, C., Geier, J.V., and Weinberg, I., "Modelling and Design of High Efficiency Radiation Tolerant Indium Phosphide Space Solar Cells," Proceedings 19th IEEE Photovoltaic Specialists Conference-1987, IEEE, Piscataway, NJ, 1987, pp. 937-943.
5. Yamaguchi, M., Uemura, C., Yamamoto, A., and Shibukawa, A., "Electron Irradiation Damage in Radiation-Resistant InP Solar Cells," Japanese Journal of Applied Physics, Vol. 23, No. 3, Mar. 1984, pp. 302-307.
6. Yamamoto, A., Yamaguchi, M., and Uemura, C., "High Conversion Efficiency and High Radiation Resistance InP Homojunction Solar Cells," Applied Physics Letters, Vol. 44, No. 6, Mar. 15, 1984, pp. 611-613.
7. Keavney, C.J., and Spitzer, M.B., "Indium Phosphide Solar Cells Made by Ion Implantation," Applied Physics Letters, Vol. 52, No. 17, Apr. 25, 1988, pp. 1439-1440.
8. Okazaki, H., Takamoto, T., Takamura, H., Kamei, T., Ura, M., Yamamoto, A., and Yamaguchi, M., "Production of High-Efficiency InP Solar Cells for Space Use," 3rd International Photovoltaic Science and Engineering Conference, Japan Society of Applied Physics, Tokyo, Japan, 1987, p. 791.
9. Weinberg, I., Swartz, C.K., Hart, R.E., Jr., Gandhi, S.K., Borrego, J.M., Parat, K.K., and Yamaguchi, M., "Comparative Radiation Resistance, Temperature Dependence and Performance of Diffused Junction Indium Phosphide Solar Cells," Solar Cells, Vol. 22, No. 2, Oct. 1987, pp. 113-124.
10. Nagatomo, M., Institute of Space and Astronautical Science, Tokyo, Private Communication.
11. Parat, K.K., and Bothra, S., Borrego, J.M., and Gandhi, S.K., "Solar Cells in Bulk InP, Made by an Open Tube Diffusion Process," Solid State Electronics, Vol. 30, No. 3, 1987, pp. 283-287.
12. Loo, R., Kamath, G.S., and Knechtli, R.C., "Radiation Damage in GaAs Solar Cells," Proceedings 14th IEEE Photovoltaic Specialists Conference-1980, IEEE, Piscataway, NJ, 1980, pp. 1090-1097.

13. Weinberg, I., Brandhorst, H.W., Jr., Swartz, C.K., and Weizer, V.G., "Radiation Damage in High Voltage Silicon Solar Cells," Photovoltaic Generators in Space, ESA SP-147, W.R. Burke, ed., European Space Agency, Paris France, 1980, pp. 129-134.
14. Weinberg, I., Swartz, C.K., Hart, R.E., Jr., and Coutts, T.J., "Radiation Resistance and Comparative Performance of ITO/InP and n/p InP Homojunction Solar Cells," Proceedings 20th IEEE Photovoltaic Specialists Conference-1988, IEEE, Piscataway, NJ, 1988. (To be published.)
15. Coutts, T.J., Solar Energy Research Inst., Golden, CO, Private Communication.
16. Goradia, C., Geier, J.V., and Weinberg, I., "Experimental and Theoretical Comparison of 1 MeV Electron-Induced Radiation Damage in InP and GaAs Space Solar Cells," 3rd International Photovoltaic Science and Engineering Conference, Japan Society of Applied Physics, Tokyo, Japan, 1987, pp. 207-210.
17. Yamaguchi, W., "Radiation Induced Defects in InP Solar Cells," 3rd International Photovoltaic Science and Engineering Conference, Japan Society of Applied Physics, Tokyo, Japan, 1987, pp. 471-476.
18. Goradia, C., Thesling, W., Goradia, M.G., Weinberg, I., and Swartz, C.K., 1988, to be published in Proceedings 9th Space Photovoltaic Research and Technology Cong. Lewis Research Center.
19. Patterson, R.E., Rauschenbach, H.S., and Cannady, M.D., "Design and Performance Trades for a Miniaturized Photovoltaic Concentrator Array," Proceedings 16th IEEE Photovoltaic Specialists Conference-1982, IEEE, Piscataway, NJ, 1982, pp. 39-44.
20. Stern, T.G., and Hayes, E.W., "Structural Design for High-Power Parabolic Trough Concentrator Arrays in Space," Proceedings 17th IEEE Photovoltaic Specialists Conference-1984, IEEE, Piscataway, NJ, 1984, pp. 326-329.
21. Goradia, C., Cleveland State University, Cleveland, OH, Private Communication.
22. Woodall, J.M., and Hovel, H.J., "High-Efficiency $Ga_{1-x}Al_xAs$ -GaAs Solar Cells," Applied Physics Letters, Vol. 21, No. 8, Oct. 15, 1972, pp. 379-381.
23. McClelland, R.W., and Bozler, C.O., and Fan, J.C.C., "A Technique for Producing Epitaxial Films on Reusable Substrates," Applied Physics Letters, Vol. 37, No. 6, Sept. 15, 1980, pp. 560-562.

TABLE I. - AIR MASS ZERO PARAMETERS OF BEST InP CELLS

[Measurements performed at NASA Lewis; total area, AMO = 137.2 mW/cm².]

Cell type	Growth method	Area, cm ²	Efficiency, percent	J _{sc} , mA/cm ²	V _{oc} , mV	FF, percent	Reference
n ⁺ pp ⁺	OMCVD and ion-implant	0.25	18.8	35.7	873	82.9	7
n ⁺ p	Closed tube diffusion	4	16.6	33.7	828	81.6	8

TABLE II. - PRE-IRRADIATION AMO PARAMETER OF CELLS

IN FIGURES 3 AND 4

Cell	Area, cm ²	Efficiency, percent	J _{sc} , mA/cm ²	V _{oc} , mV	FF, percent
n/p InP	2	16.4	32.9	825	83
n/p InP	0.25	13.6	27.6	826	81.8
ITO/InP	0.717	13.2	32.6	761	78
n/p GaAs	4	16.6	29	960	81.8

TABLE III. - PRE-IRRADIATION CELL PARAMETERS USED IN THEORETICAL

COMPARISON OF InP AND GaAs

	InP	GaAs
Junction area, cm ²	1.00	1.00
Total illuminated area, cm ²	0.94	0.94
Grid coverage, percent	6.00	6.00
Specific contact resistance, Ω-cm ²	1.0x10 ⁻³	1.0x10 ⁻³
Front surface recombination velocity, cm/sec	1.0x10 ⁵	3.0x10 ⁵
n ⁺ emitter width, Å	400	400
n ⁺ emitter doping, cm ⁻³	6.0x10 ¹⁷	6.0x10 ¹⁷
p base width, μm	1.50	1.50
p base doping, cm ⁻³	5.0x10 ¹⁶	5.0x10 ¹⁶
p ⁺ BSF/buffer layer width, μm	250	250
p ⁺ BSF/buffer layer doping, cm ⁻³	5.0x10 ¹⁸	5.0x10 ¹⁸

TABLE IV. - GENERAL PARAMETERS OF NEAR-OPTIMUM CONCENTRATOR

CELL DESIGNS

	Rectangular	Circular
Total area, A, cm ²	0.25	0.1257
Grid shadowing, percent	4	4
AR coating, Å SiO	750	750
Specific contact resistance, R _{ms} , Ω-cm ²		
To n+ emitter	2x10 ⁻⁵	2x10 ⁻⁵
To p+ BSF layer	1x10 ⁻³	1x10 ⁻³
Series resistance, R _s , mΩ	59.7	92
Shunt resistance, R _{sh} , Ω	1x10 ⁷	1x10 ⁷
Bandgap of InP at 300 K, E _g , eV	1.35	1.35
Intrinsic carrier concentration n _i at 300 K, cm ⁻³	1.65x10 ⁷	1.65x10 ⁵
Effective front SRV, S _f , cm/sec	1.1x10 ⁵	1.1x10 ⁵

TABLE V. - GEOMETRICAL AND MATERIAL PARAMETERS OF NEAR-OPTIMUM CELL DESIGN

[The following parameters are identical for both rectangular and circular cells.]

Emitter	
Width, W _E , μm (Å)	0.04 (400)
Doping, N _{dE} , cm ⁻³	2x10 ¹⁸
Effective lifetime, τ _{pE} , ns	1.26
Diffusion length, L _{pE} , μm	0.42
Base	
Width, W _B , μm	1.5
Doping, N _{aB} , cm ⁻³	5x10 ¹⁶
Effective lifetime, τ _n , ns	17.8
Diffusion length, L _{nB} , μm	12.75
BSF region	
Width, W _{BSF} , μm	250
Doping, N _{a,BSF} , cm ⁻³	5x10 ¹⁸
Effective lifetime, τ _{n,BSF} , ns	0.18
Diffusion length, L _{n,BSF} , μm	1.06

TABLE VI. - CALCULATED PERFORMANCE OF

InP CONCENTRATOR CELLS AT 80 °C

	20 AMO (rectangular)	100 AMO (circular)
J _{sc} , A/cm ²	0.764	3.821
V _{oc} , mV	896.8	946.2
FF, percent	83.72	81.40
η, percent	20.57	21.10

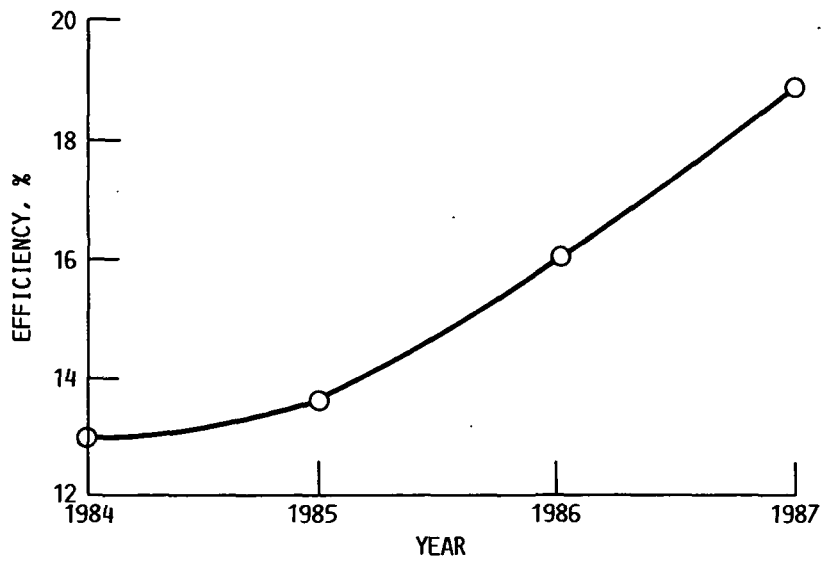

FIGURE 1. - InP - PROGRESS IN ACHIEVING HIGH-EFFICIENCY.

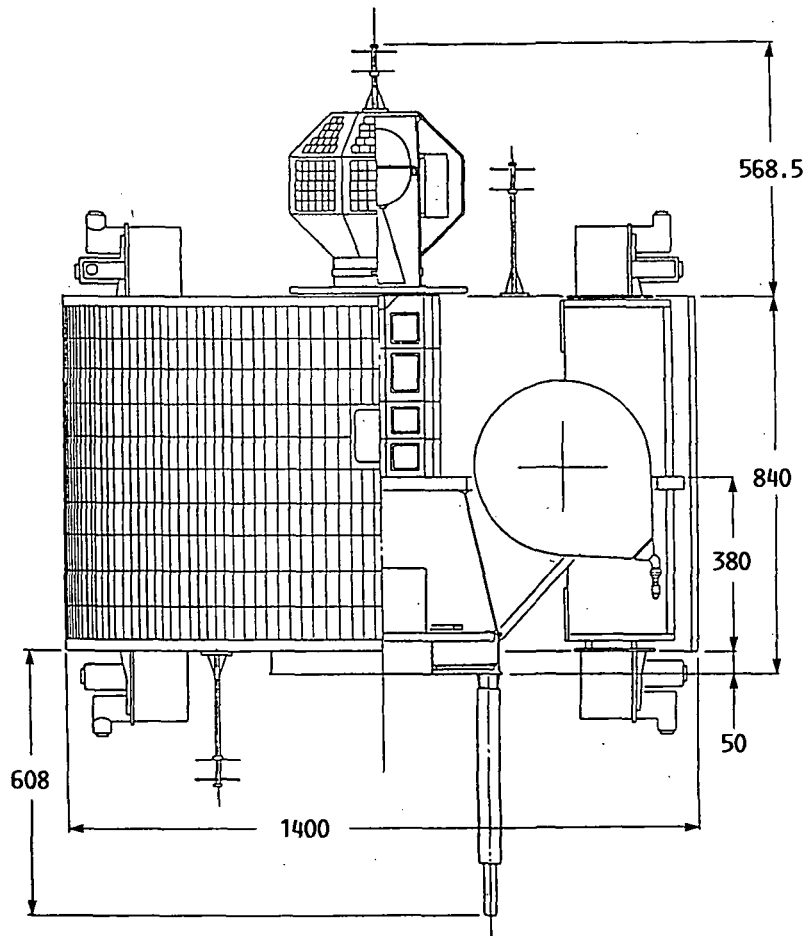

FIGURE 2. - MUSES-A SPACECRAFT AND LUNAR ORBITER. DIMENSIONS ARE IN MILLIMETERS.

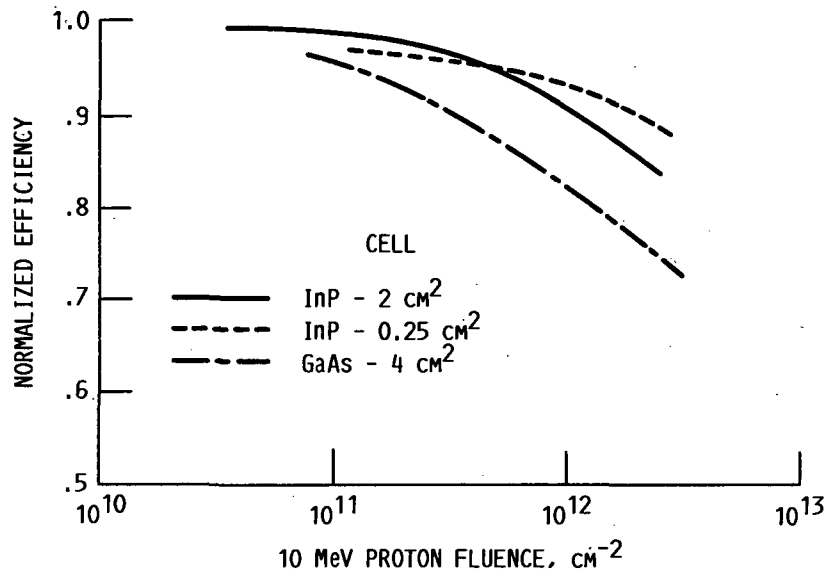

FIGURE 3. - NORMALIZED EFFICIENCIES UNDER 10 MeV PROTON IRRADIATION InP AND GaAs.

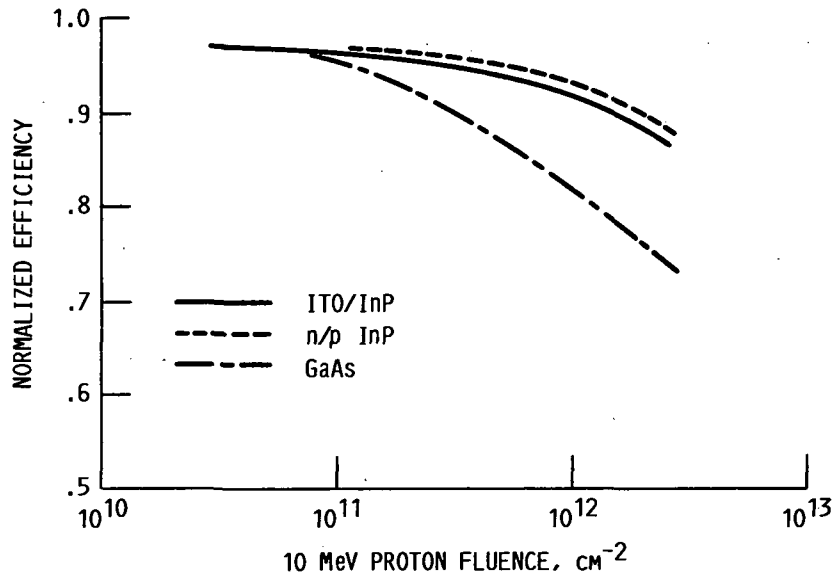

FIGURE 4. - NORMALIZED EFFICIENCIES UNDER 10 MeV PROTON IRRADIATION ITO/InP, n/p InP, AND GaAs.

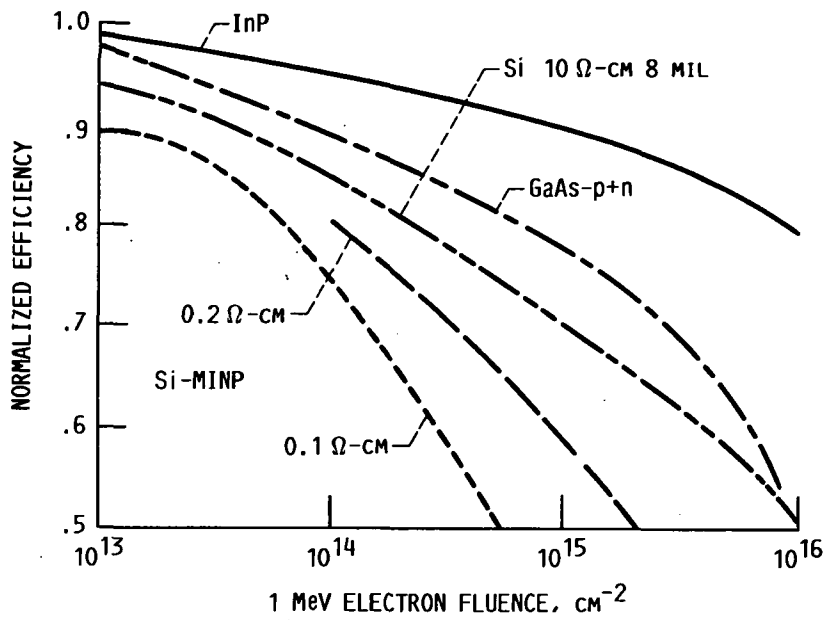

FIGURE 5. - PERFORMANCE OF InP, GaAs, AND Si SOLAR CELLS UNDER 1 MeV ELECTRON IRRADIATION.

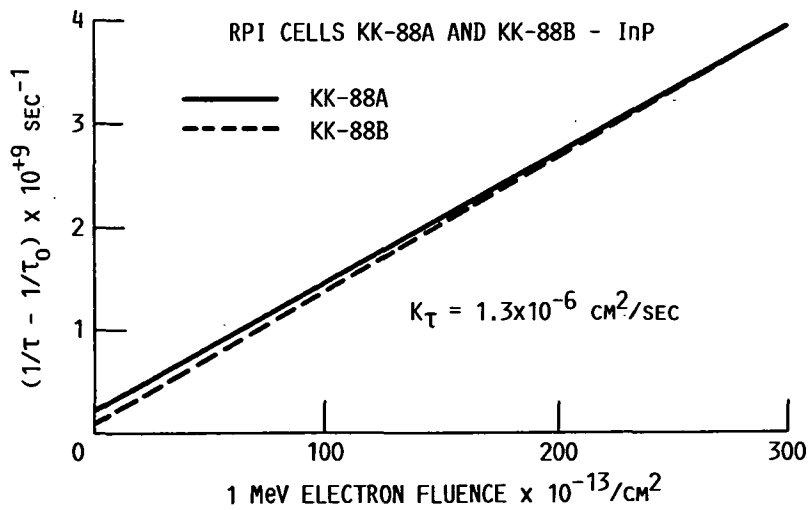

FIGURE 6. - GRAPHICAL PLOTS USED TO OBTAIN LIFETIME DAMAGE COEFFICIENTS FOR InP.

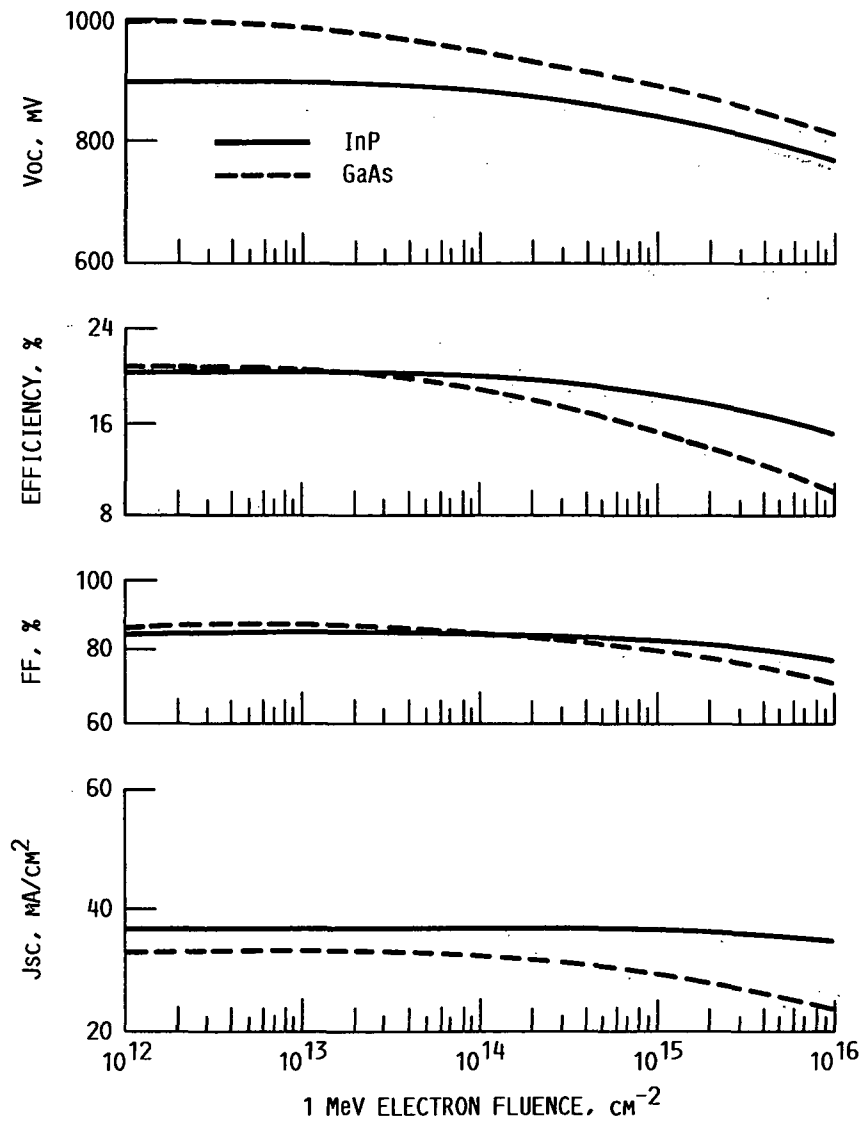

FIGURE 7. - PERFORMANCE PARAMETERS VERSUS 1 MeV e^- FLUENCE: THEORETICAL VARIATION FOR InP AND GaAs.

ORIGINAL PAGE IS
OF POOR QUALITY

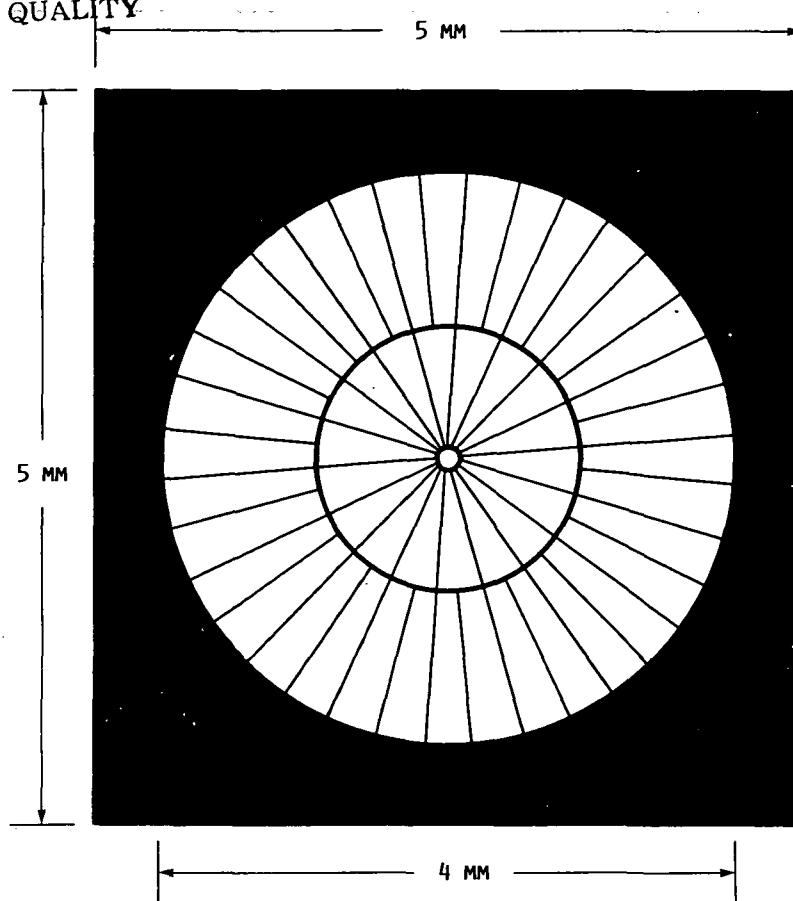

FIGURE 8. - CIRCULAR CELL FOR CASSEGRAINIAN CONCENTRATOR
100 AMO, 80 °C.

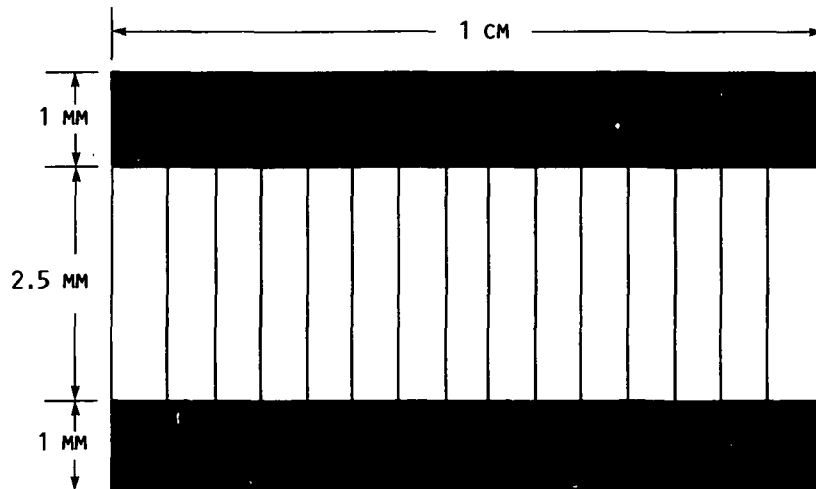

FIGURE 9. - RECTANGULAR CELL FOR SLATS CONCENTRATOR 20 AMO,
80 °C.

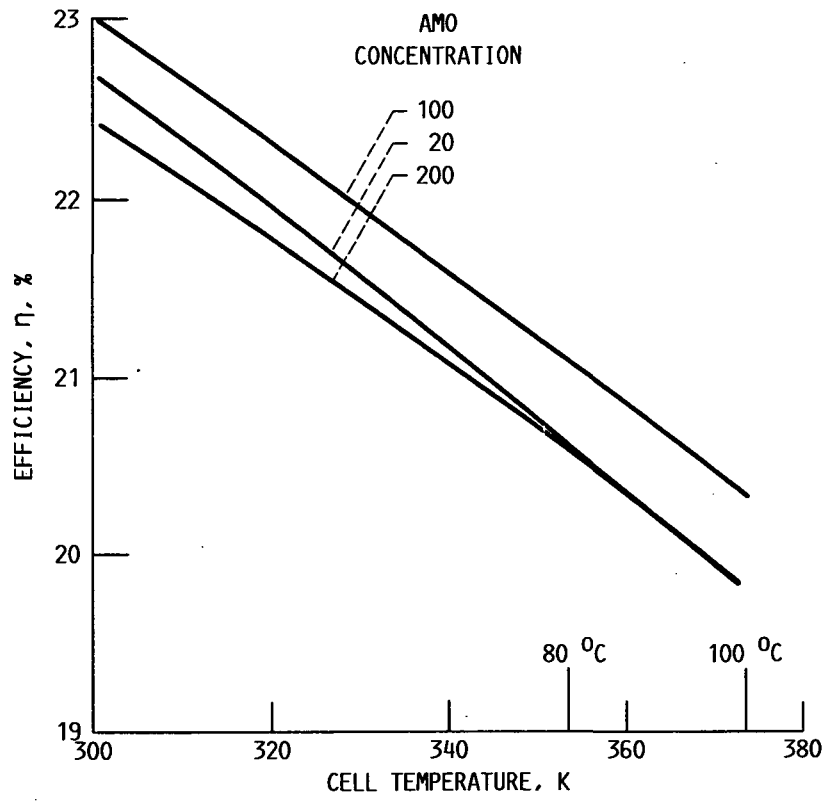

FIGURE 10. - EFFICIENCY VERSUS TEMPERATURE AT VARIOUS AMO CONCENTRATIONS - CIRCULAR CELLS.

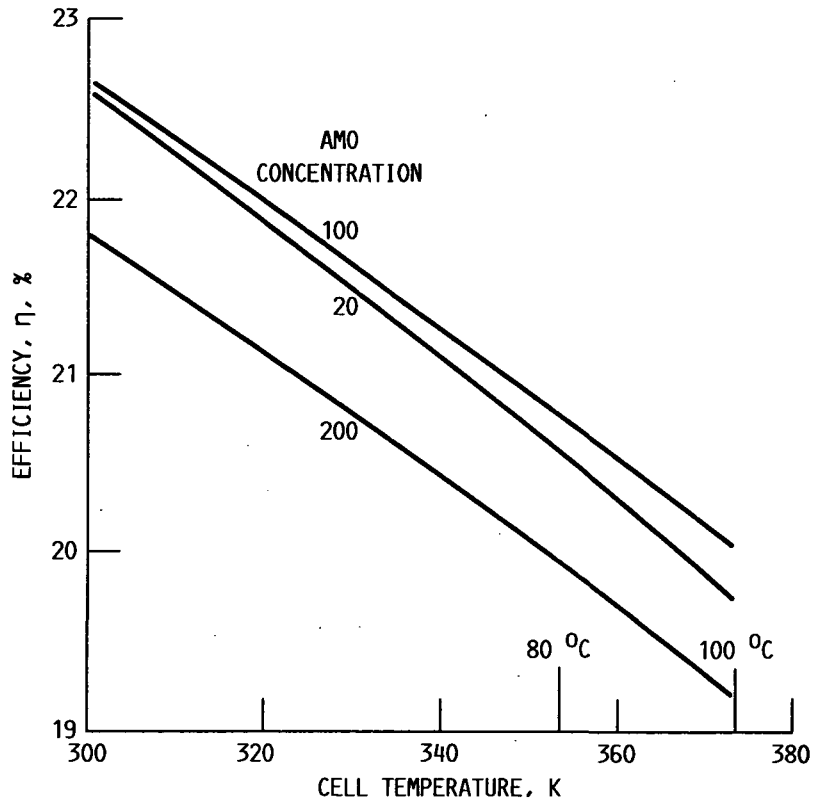

FIGURE 11. - EFFICIENCY VERSUS TEMPERATURE AT VARIOUS AMO CONCENTRATIONS - RECTANGULAR CELLS.

1. Report No. NASA TM-100914		2. Government Accession No.		3. Recipient's Catalog No.	
4. Title and Subtitle Progress in InP Solar Cell Research				5. Report Date	
				6. Performing Organization Code	
7. Author(s) Irving Weinberg and David J. Brinker				8. Performing Organization Report No. E-4166	
				10. Work Unit No. 506-41-11	
9. Performing Organization Name and Address National Aeronautics and Space Administration Lewis Research Center Cleveland, Ohio 44135-3191				11. Contract or Grant No.	
				13. Type of Report and Period Covered Technical Memorandum	
12. Sponsoring Agency Name and Address National Aeronautics and Space Administration Washington, D.C. 20546-0001				14. Sponsoring Agency Code	
15. Supplementary Notes Prepared for the 23rd Intersociety Energy Conversion Engineering Conference cosponsored by the ASME, AIAA, ANS, SAE, IEEE, ACS, and AIChE, Denver, Colorado, July 31 - August 5, 1988.					
16. Abstract Progress, during the past year, in InP solar cell research is reviewed. Small area cells with AMO, total area efficiencies of 18.8 percent were produced by OMCVD and Ion-Implantation. Larger area cells (2 cm² and 4 cm²) were processed on a production basis. One thousand of the 2 cm² cells will be used to supply power to a small piggyback lunar orbiter scheduled for launch in February 1990. Laboratory tests of ITO/InP cells, under 10 MeV proton irradiation, indicate radiation resistance comparable to InP n/p homojunction cells. Computer modelling studies indicate that, for identical geometries and dopant concentrations, InP solar cells are significantly more radiation resistant than GaAs under 1 MeV electron irradiation. Additional computer modelling calculations were used to produce rectangular and circular InP concentrator cell designs for both the low concentration SLATS and higher concentration Cassegranian Concentrators.					
17. Key Words (Suggested by Author(s)) Solar cells Indium phosphide Gallium arsenide			18. Distribution Statement Unclassified - Unlimited Subject Category 33		
19. Security Classif. (of this report) Unclassified		20. Security Classif. (of this page) Unclassified		21. No of pages 16	22. Price* A02

National Aeronautics and
Space Administration

Lewis Research Center
Cleveland, Ohio 44135

Official Business
Penalty for Private Use \$300

SECOND CLASS MAIL

ADDRESS CORRECTION REQUESTED



Postage and Fees Paid
National Aeronautics and
Space Administration
NASA-451

NASA
