

NASA-CP-2498 19880015721

NASA Conference Publication 2498

Meteorological and Environmental Inputs to Aviation Systems

LANGLEY RESEARCH CENTER
LIBRARY, NASA
HAMPTON, VIRGINIA

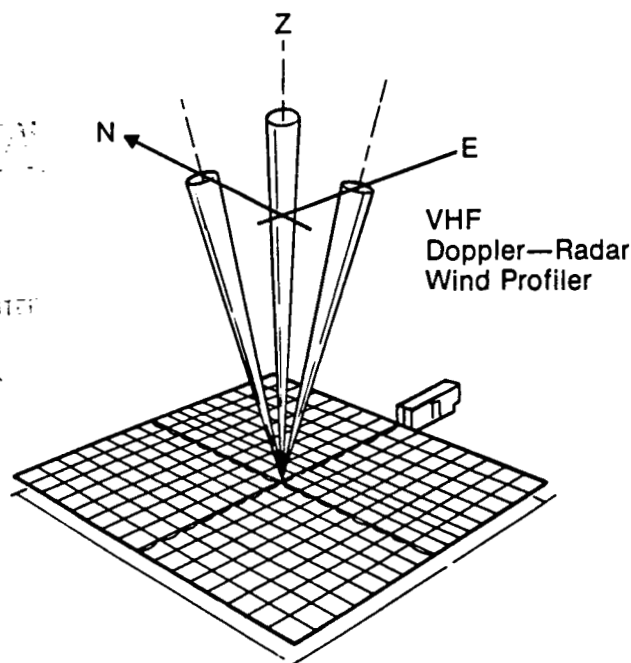

*Proceedings of a workshop held at the
University of Tennessee Space Institute in
Tullahoma, Tennessee
March 12-14, 1985*

NASA

Meteorological and Environmental Inputs to Aviation Systems

Edited by
Dennis W. Camp and Walter Frost
University of Tennessee Space Institute
Tullahoma, Tennessee

Proceedings of a workshop jointly sponsored by the
National Aeronautics and Space Administration,
National Oceanic and Atmospheric Administration
(Department of Commerce), Federal Aviation
Administration (Department of Transportation),
Department of Defense, and Office of the Federal
Coordinator for Meteorology, and held at the
University of Tennessee Space Institute in
Tullahoma, Tennessee
March 12-14, 1985



National Aeronautics
and Space Administration

Scientific and Technical
Information Division

PREFACE

The first in a series of annual workshops addressing meteorological inputs to aviation systems was held on March 17-19, 1977, at the University of Tennessee Space Institute in Tullahoma, Tennessee. The workshops were initially sponsored by NASA, NOAA and the FAA, and were later joined in sponsorship by DOD and the Office of the Federal Coordinator. They have provided a forum for open discussion of weather and environmental concerns between the research, operations and user organizations within the aviation community. Following the past few workshops, several individuals have voiced concern over the benefit of what has become a continuing workshop with in many instances the same continuing recommendations. To assess the value of a continuing workshop one must look beyond a simple comparison of recommendations made year to year. Although problems appear very rapidly, such as those resulting from an accident, solutions usually span many years and involve time-consuming activities such as funding cycles, studies, experiments, and cooperation from multiple organizations. The values I would give high marks to are in programmatic guidance and communication.

Over the history of this workshop I have seen programs within my own organization NASA initiated and/or guided from information gained here at Tullahoma. The task of communicating is difficult when people are on the same side of an issue; it is almost impossible when requirements of operators, researchers, and users are debated before the Congress or the public in a competitive environment. The continuing Workshops on Meteorological and Environmental Inputs To Aviation Systems provide a needed non-competitive atmosphere for open discussion of aviation problems and a critique of ongoing activities from a diversified, but involved audience.

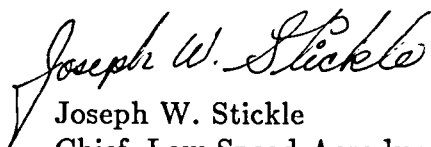

Joseph W. Stickle
Chief, Low-Speed Aerodynamics Division

TABLE OF CONTENTS

I. EXECUTIVE SUMMARY	1
II. INTRODUCTION AND WELCOME	17
III. OVERVIEW PRESENTATIONS	23
AUTOMATION OF SURFACE OBSERVATIONS PROGRAM	
Steve E. Short	25
BRACKNELL METEOROLOGICAL OFFICE	
Colin R. Flood	41
SPECIAL OBSERVATIONS	
Donald Beran	53
APPLICATIONS PRODUCTS OF AVIATION FORECAST MODELS	
John P. Garthner	67
GENERAL-AVIATION'S VIEW OF PROGRESS IN THE AVIATION WEATHER SYSTEM	
Douglas J. Lundgren	79
PANEL DISCUSSION FOLLOWING OVERVIEW PRESENTATIONS .	87
IV. BANQUET PRESENTATION	
Dub Yarbrough	97
V. IMPROMPTU PRESENTATIONS	101
AIRCRAFT/LIDAR TURBULENCE COMPARISON	
Kao-Huah Huang	103
LIGHTNING DETECTION AND LOCATING SYSTEMS	
Russell L. Hovey	115
NATIONAL PLANS FOR AIRCRAFT ICING AND IMPROVED AIRCRAFT ICING FORECASTS AND ASSOCIATED WARNING SERVICES	
Ralph P. Pass	121

OBJECTIVE DETECTION AND FORECASTING OF CAT: A STATUS REPORT John L. Keller	125
COMPARATIVE VERIFICATION BETWEEN GEM AND OFFICIAL AVIATION TERMINAL FORECASTS Robert G. Miller	133
COMPUTER AND MODEL CHANGES AT NMC Charles H. Sprinkle	139
DENVER ARTCC EVALUATION OF PROFS MESOSCALE WEATHER PRODUCTS John W. Hinkelman	145
THE FAA/M.I.T. LINCOLN LABORATORY DOPPLER WEATHER RADAR PROGRAM James E. Evans	155
VI. COMMITTEE SUMMARY REPORTS	167
SUMMARY REPORT: OBSERVING WEATHER Chairman: Alexander E. MacDonald	169
SUMMARY REPORT: PRODUCTS AND SERVICES Chairman: Col. John W. Oliver	174
SUMMARY REPORT: SPECIAL OBSERVATIONS Chairman: Gerald F. O'Brien	179
SUMMARY REPORT: AVIATION FORECAST MODELS Chairman: Raymond J. Stralka	185
SUMMARY REPORT: USING THE SYSTEM Chairman: John R. Gallimore	189
SUMMARY REPORT: PASSENGER AIRLINES Chairman: Russell Crawford	191

SUMMARY REPORT: CARGO AIRLINES	
Chairman: William H. Pickron	195
SUMMARY REPORT: CORPORATE AVIATION	
Chairman: Richard J. Van Gemert	198
SUMMARY REPORT: GENERAL AVIATION	
Chairman: Elaine McCoy	202
SUMMARY REPORT: MILITARY AVIATION	
Chairman: Lt. Col. James L. Crook	205
VII. CONCLUDING REMARKS	211
APPENDICES	215
APPENDIX A: LIST OF ACRONYMS	217
APPENDIX B: ROSTER OF WORKSHOP PARTICIPANTS	225

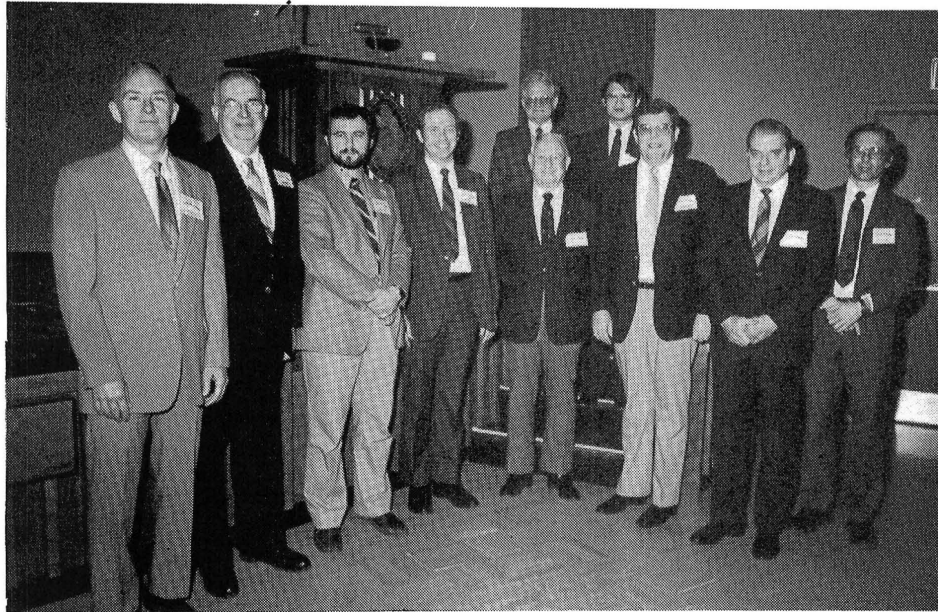
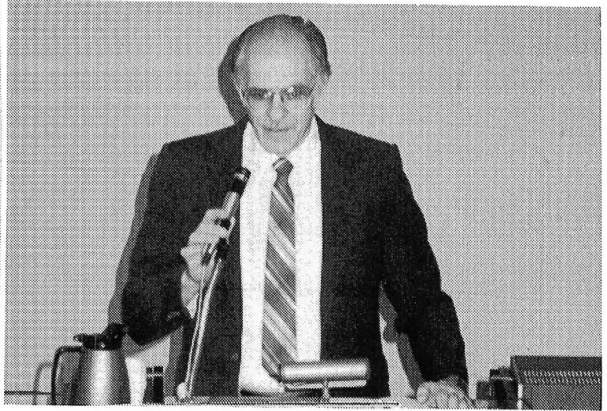

COMMITTEES

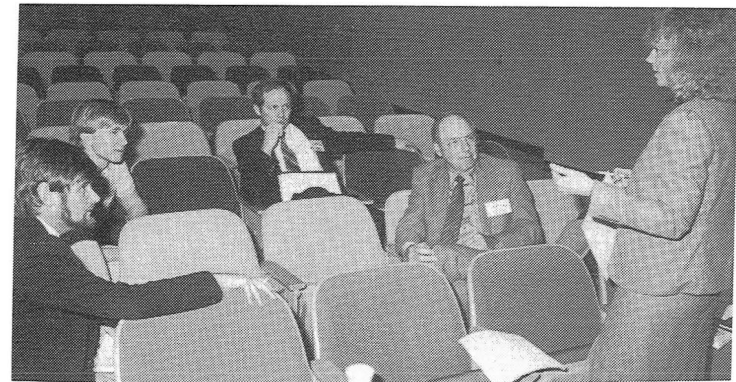
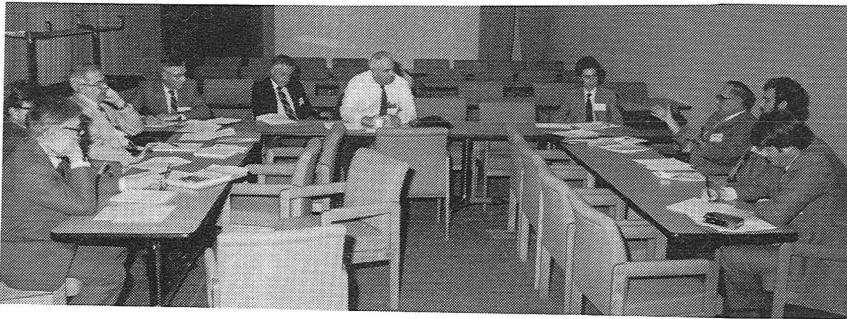

x



SECTION I
EXECUTIVE SUMMARY

EXECUTIVE SUMMARY

Introduction

There have been seven workshops concerned with meteorological and environmental inputs to aviation systems. The first one was held in March 1977 and the last in March 1985. These workshops have served a twofold purpose for the government sponsors (NASA, FAA, NOAA, DOD, and OFCM). Their first purpose was to bring together the various disciplines of the aviation community with atmospheric scientists and meteorologists in interactive discussions concerning needs of the community and how to satisfy these needs. Their second purpose was to use the established and identified needs to develop recommendations that serve as a basis for structuring relevant programs of the sponsoring agencies. An indication of how well the purpose of these workshops has been achieved is given in the various reports, papers, and presentations that have been made on the workshops (Camp and Frost, 1977, 1979, 1981, 1985a, 1985b; Camp, et al. 1980a, 1980b, 1981; Frost and Camp, 1978, 1980, 1982, 1983, Frost, et al. 1979a, 1979b; and Miller, 1987; [1-16]). Due to the coverage of the previous workshops, this article will be concerned only with the results (recommendations) of the seventh workshop.

Workshop Structure and Operation

The basic objective of all the workshops has been and is to satisfy the needs of the sponsoring agencies relative to such factors as 1) Knowledge of the interaction of the atmosphere with aircraft and airport operations, 2) Better definition and implementation of meteorological services for the operators, and 3) The collection and interpretation of data for establishing operational criteria relating the total meteorological inputs from the atmospheric sciences to the operational and educational needs of the aviation community.

The specific theme of each workshop gives an insight into its particular focus. "Aviation Weather/Observing, Distributing, and Using the Products" was the theme for the Eighth Annual Workshop on Meteorological and Environmental Inputs to Aviation Systems. This workshop theme, coupled with the focusing of the interactive committees, according to the committee titles (Table 1), tended to direct the workshop in the desired area of effort. These interactive committee sessions are considered to be a major element contributing to the success of the annual workshops.

The type of information desired from the interactive committee sessions was what was the effect of the particular subject area (Fixed Committee Title) on

the operation of the various segments (Floating Committee Title) of the aviation community? Each of the committees was asked to focus its discussion according to the committee guidelines given in Table 2.

The workshop began with a series of five overview papers (Table 3). Papers on previous workshop accomplishments, interactive weather displays, and impromptu tasks were also given. These also helped to set the tempo in the vein of the workshop theme, as did the banquet and dinner presentations.

The structure (program) of this workshop was very similar to previous workshops. It began with the overview presentations, followed in order by interactive committee sessions, banquet, impromptu presentations, more interactive committee sessions, dinner presentation, more interactive committee sessions, and a conclusion with a plenary session consisting of the committee chairmen presenting the results and recommendations of their committees.

Comments and Recommendations

At this workshop, the committee chairmen were requested to use a special procedure (form) for reporting their comments and recommendations. Specifically, they were asked to give the results of their efforts in the following order: 1) state as concisely as possible the issue, 2) briefly summarize the discussion of the issue, 3) state recommended action, 4) indicate who should be responsible for accomplishing any required effort, and 5) specify the priority of issues discussed.

TABLE 1.

INTERACTIVE COMMITTEE TITLES FOR THE EIGHTH WORKSHOP

FIXED COMMITTEES	FLOATING COMMITTEES
1. Observing Weather	1. Passenger Airlines
2. Products and Services	2. Cargo Airlines
3. Special Observations	3. Corporate Airlines
4. Aviation Forecast Models	4. General Aviation
5. Using the System	5. Military Aviation

TABLE 2.
COMMITTEE GUIDELINES

1. What are the major problem areas with respect to the list of meteorological topics given below which exist relative to safety and operations as they pertain to the categories of aviation operations identified by the committee titles?
2. What current aspects of existing technology, operational procedures, or facilities cause these problems?
3. Specify what action is needed to overcome or alleviate these problems.
4. What sector of the aviation community should accept the responsibility for rectifying these problems?
5. Prioritize the action recommended in Step 3.

Meteorological Topics

- A. Winds and Wind Shear
- B. Turbulence
- C. Fog, Visibility, and Ceiling
- D. Lightning and Atmospheric Electricity
- E. Icing, Frost, and Snow
- F. Rain
- G. Ozone, Acid Rain, and any other meteorological parameters suggested by committee members.

TABLE 3.
LIST OF OVERVIEW PAPERS

TITLE	AUTHOR	AFFILIATION
1. Automation of Surface Observation Program	Steve E. Short	NOAA/NWS
2. Brackwell Meteorological Office	Colin R. Flood	British Met. Office
3. Special Observations	Donald Beran	NOAA/ERL
4. Aviation Forecast Models	John P. Garthner	U.S. Navy
5. General Aviation's View of Progress in the Aviation Weather System	Douglas J. Lundgren	AOPA

The committees stated 59 issues with respective recommendations for each. Of these, there was an indication that 4 were in a very high-priority category, 40 were in a high category, 13 were considered to be of medium priority, and two were not rated. These recommendations could be sorted into several classes. Some of the recommendations could easily fit into two or more of the classes. Some of the recommendations are quite similar and can be combined. The ones presented here should not be considered as the more important of the high-priority recommendations, but only a sample of them. For a more in-depth discussion of the comments and recommendations the proceedings (Frost and Camp, 1987 [13]) should be pursued.

ISSUE: Establishment of a driving force for workshop recommendation implementation.

DISCUSSION:

In this day and age of reduced budgets for both dollars and manpower and increased competition for the same, it is essential that the end users in the aviation systems strongly support the implementation of the workshop recommendations. During the past seven workshops, many issues have been discussed and recommendations have been made regarding actions to be taken by various governmental agencies. Many studies, research activities and development programs have been initiated as a result. A large number of those issues and recommendations have been discussed again and agreed to at this eighth workshop by essentially new participants.

Very often, during these interactive discussions, the comment was made by the government technical people that they lacked the strength and resources to be the advocates for the implementation of the workshop recommendations. We believe that the end users in the aviation systems should integrate these recommendations into their agendas and proceed with the political process of establishing the public need for the products and services recommended. A coordinated approach by such responsible organizations as ALPA, AOPA, ATA, GAMA, NBAA, HAA, FSF and RAA would go far in establishing the public need and could provide the impetus for timely implementation of the workshop recommendations.

RECOMMENDED ACTION

An editorial committee composed of the chairpersons for the fixed and floating committees should be established immediately to produce an executive summary of the recommendations of all of the workshops (one through eight). This summary should then be sent to the aviation system user organizations (as above) for integration into their agendas.

RESPONSIBLE AGENCIES: Workshop Organization Committee and Committee

Chairpersons.

PRIORITY: Highest Possible

ISSUE: Implementation of automated observations into nationwide operations.

DISCUSSION:

Automation offers an opportunity for substantial improvement of services. It allows for expansion of services into smaller airports (e.g., FAA; AWOS Program; and non-federal programs), as well as expansion of hours at many part-time FAA and NWS locations. This opportunity, however, entails certain risks that need to be managed carefully. Specific concerns are

- Need for completeness of observation where required to support commercial operations
- Need for representatives of the automatically provided visual element (e.g., index of visibility, ceiling conditions)
- Need for sufficiently rigorous system standards and ongoing operational quality control

RECOMMENDED ACTIONS:

- Strong support is made for AWOS-level automation at unmanned airports (however, inclusion of lightning detection is recommended)
- For current manned observation sites, observer augmentation of the system (both AWOS and ASOS) as necessary for critical information such as precipitation discrimination, and retention of remarks (e.g., fog bank cast)
- Need exists for validation and demonstration of sensed parameters for representatives of observation, and use of multiple sensors as necessary (e.g., multiple visibility sensors where non-homogeneous conditions are common)
- Require sufficiently stringent design standards and institute rigorous operational quality control procedures sufficient to meet the aviation safety requirements

RESPONSIBLE AGENCIES: FAA, NWS

ISSUE: Can profilers provide the added temporal and spatial density of wind data and short-term forecasts for lower-level flights for both flight economy and safety?

DISCUSSION:

It is unlikely that profilers will be able to satisfy the need for both boundary-layer and jet-stream level winds at reasonable cost.

Most likely, profilers will provide highly accurate winds above 2,000 ft. to 3,000 ft. but only at profiler sites which may be 200 km or more apart. Local terrain effects may not be resolved with such a network.

NEXRAD will have the capability of observing clear-air wind profiles in the lower few thousand feet of the atmospheric boundary layer on most days.

RECOMMENDED ACTION:

Explore techniques for combining the temporal density of profiler measurements in a network configuration with diagnostic models to generate mesoscale wind fields.

Also ensure the development of NEXRAD techniques to provide low-level clean-air wind fields.

RESPONSIBLE AGENCY: NOAA

ISSUE: Need 6-hour updated global temperature/wind forecast fields.

DISCUSSION:

This action is needed for computer flight planning; it would reduce forecast time period for a better product and would save airlines millions of dollars:

- 6-hour updates must include “off-time” sources of wind/temperature data such as PIREPs, profilers, special rawinsonde runs, R&D set-ups, etc.
- Incremental improvements must be weighed against “opportunity costs” such as delays in other products/services that may result.

RECOMMENDED ACTION:

Submit this proposal to NWS for consideration.

RESPONSIBLE AGENCIES: NWS, NMC

ISSUE: NEXRAD-derived parameters are needed by the meteorological community to improve forecasting of turbulence, icing, low-level wind shear events, and severe thunderstorms/tornadoes.

DISCUSSION:

It was noted by pilots and meteorologists that the state of forecasting turbulence (clean-air turbulence, in particular), icing conditions, and low-level wind shear has not changed significantly in over three decades and that better forecasting skills must be developed. Operational forecasters require additional meteorological data for analysis and on which to base predictions. NEXRAD Doppler radar will provide additional information useful to a meteorologist in the detection and forecasting of wind shear, turbulence and severe weather. Doppler radar provides the best known means of detecting microburst events which are potentially devastating to the flying community. NEXRAD offers diagnostic software that, in turn, offers valuable analysis information and reduces manpower requirements.

RECOMMENDED ACTION:

Continue support of NEXRAD project to aid in the detection, nowcast, and forecast of weather phenomena dangerous to aviation.

RESPONSIBLE AGENCIES: FAA, DOD, DOC

PRIORITY: High

ISSUE: Wind shear during approach and takeoff continues to be a serious problem for aircraft operators. Installation of terminal Doppler weather radar is not yet in the FAA's plans and there is disagreement on deployment techniques. Limited nationwide coverage of airports by a fully deployed system and ground-to-air weather advisories limited by available communication channels point to a need for airborne detection systems, which do not yet exist.

DISCUSSION:

There have been a number of accidents caused by wind shear. The current Low-Level Wind Shear Alert System (LLWSAS) does not appear to be the ultimate answer, and efforts on development of an on-board Doppler system appear to be grinding to a halt because of lack of financial support. The FAA does not have an approval program for development of a terminal Doppler radar system. With respect to on-aircraft detection systems, most of the aviation groups indicated high interest in advance warning of wind shear conditions, providing the system can be reasonable in cost and lightweight. In particular, cargo carriers and military aviation would like to identify gust fronts as well as microburst/downburst activity prior to penetration. (Helicopters are especially vulnerable to 15 Kn gust fronts). Passenger carriers pointed out that on-board detection systems were recommended by the 1983 NAS report, if hardware could be developed.

RECOMMENDED ACTION:

Support efforts to complete research on the terminal Doppler radar while continuing research on airborne detection systems, alternately, and implement operational systems at a reasonable cost.

RESPONSIBLE AGENCIES: FAA, NWS, DOD, NASA

ISSUE: There is dissatisfaction with the accuracy of icing reports and with interpretation of both forecasts and reports.

DISCUSSION:

Future improvements may be expected to arise from current revisions in our understanding of storm structures and from new observing systems such as radiometers for the detection of liquid water. Current problems stem from both lack of accuracy and problems with interpretation. Accuracy may be improved through research that combines new observing systems with experimental forecasting development. Problems with interpretation include the current aircraft-dependence of icing severity reports and the inconsistency between certification requirements and reporting conventions.

RECOMMENDED ACTIONS:

Support current efforts to review reporting conventions and certification requirements. Encourage new research into icing forecasting which could combine new sensors with improved knowledge of storm structures.

RESPONSIBLE AGENCIES: NWS, DOD, NASA

ISSUE: Terminal Forecasts: Need improvements

- Decreasing number of operating hours at various terminals;
- Man-made TF's often don't adequately take into account the effects of local conditions;
- Failure rate of automated systems when they become widespread is of concern.

DISCUSSION:

The hours during which airport TF's are available are decreasing. This is a particular problem for night flyers such as the cargo airlines. The problem can be remedied by using models such as GEM (Miller, 1987 [16]). This model is airport and time independent. GEM has already been shown to provide better forecasts

than man-made TF's inside 3 hours relative to the persistence and predominance of conditions. GEM is currently under development and testing to predict weather conditions from the automated observations (AWOS, ASOS). The output of hourly GEM can be produced on a micro-computer and is able to operate using special or record observations. Reliability of automated observation systems such as AWOS has been found to be fairly high.

RECOMMENDED ACTION: AWOS

Implement

RESPONSIBLE AGENCIES: NWS, FAA

ISSUE: AWOS implementation at remote and unmanned IFR airports is long overdue. AWOS is essential for safe and efficient operation for both ATC and NWS observations and forecasting.

DISCUSSION:

AWOS can be enhanced by adding several features:

- Satellite interrogation can add AWOS sensors into the meteorological network for enhanced area and frontal weather activity information. Temperature should be transmitted in tenths of 1⁰C or better to develop more useful trend data .
- Include ATC two-way communications at remote AWOS sites. This can enhance IRF efficiency, number of aircraft serviced, and operational safety.
- Include remote-controlled TV camera (controllable by ATC are controller, NWS personnel, etc.) for observing airport precipitation, general visibility and runway conditions for snow cover, etc.
- Include AWOS at controlled/manned airports and access by satellite up/down link. This will permit direct NWS computer access.

Digital computers need real-time precise data. Declining weather conditions can be monitored and data updated every five minutes, if needed, adding potentially a quantum jump in weather data quality, both in nowcasts and forecasts.

RECOMMENDED ACTIONS:

Implement satellite up/downlinked AWOS stations at all IFR airports. Twenty percent of all IFR airports should have installation completed and operational each

year beginning in 1987.

RESPONSIBLE AGENCIES: FAA and NWS, jointly. (Funding: Aviation Trust Fund)

ISSUE: There is a need for weather education for pilots.

DISCUSSION:

General-aviation facilities often cause weather-related accidents. Current testing procedures are inadequate for establishing pilot competency with regard to weather criteria, and weather theory study is in need of reinforcement. For example, written exams currently permit an applicant to pass the exam even if missing all weather-related items, while the BFR, a key opportunity for competency checks in all areas, fails to incorporate weather review by regulation. Additionally, updates of aviation weather and aviation weather knowledge, weather-related pilot judgment skills need to be enhanced through textual-situational judgment training to further compound the problem of weather education. The influx of new service including automated self-briefing to the general-aviation community is occurring without plans at the national level for a familiarization or educational program covering these options. Inactive or low-time pilots may not know the available options or the diversity of formats appearing in the private and governmental sectors.

RECOMMENDED ACTIONS:

- Require demonstrated meteorological knowledge at written, oral, and practical test levels for obtaining airmen certificates
- Require the BFR to incorporate demonstrated weather competency
- Encourage flight instructors to emphasize the importance of weather theory through certification procedures and flight refresher clinics
- Incorporate weather judgment training in flight training
- Utilize accident prevention seminars to assist pilots in using all services available for preflight briefing
- In letters to airmen, indicate specific facility improvements as well as national improvements (Aviation Services Branch)
- Update aviation weather services

RESPONSIBLE AGENCIES: FAA, NWS, NTSB, Air Safety Foundation, AOPA,

educational institutions, flight schools, etc.

ISSUE: There is a military need for in-flight detection turbulence potential at normal cruise altitudes as well as in low-level flight operations.

DISCUSSION:

High-performance military aircraft and helicopters are not exempt from the hazards of clear-air turbulence. In fact, military missions, such as in-flight refueling and terrain-following flight at all speeds, require maximum aerodynamic performance of aircraft and cruise missiles.

Simultaneously, there is presently considerable emphasis on the potential hazards of wind shear in the airport vicinity. Remote detection and in-flight warning or control (e.g., cruise missile, Space Shuttle) are needed for mission success and safety of flight.

RECOMMENDED ACTION:

Cooperative efforts in turbulence research and instrumentation development which will simultaneously satisfy military and civilian objectives are needed.

RESPONSIBLE AGENCIES: DOD, NASA, FAA, NOAA

ISSUE: Modeling for usable icing parameters.

DISCUSSION:

Present information is too vague and not airframe dependent (1950's technology).

Model output should include the variables required to enter icing curves provided by the aircraft manufacturer.

Examples:

- a) liquid water content
- b) type of cloud (stratus, cumulus)
- c) vertical extent of cloud-temperature below freezing
- d) vertical velocity
- e) area extent
- f) age of the cloud system

Present models are not capable of depicting freezing rain. Plans are being formed to define the icing problem.

RECOMMENDED ACTIONS:

- Advocate continuing efforts to develop specifications pertaining to aircraft icing
- Encourage the modelers at NMC, British Meteorological Office, USN and USAF to provide the required parameters
- Encourage industry to develop frames of reference for icing on various airframes in use today and proposed for the future

RESPONSIBLE AGENCIES: NMC, DOD, Aircraft Industry, British Met. Office

PRIORITY: High

REFERENCES

1. Camp, D. W., and W. Frost, 1977: Proceedings: First Annual Workshop on Meteorological and Environmental Inputs to Aviation Systems, 8-10 March 1977, NASA CP-2028/FAA-RD-77-173, Washington, DC, 327 pp.
2. Camp, D. W., and W. Frost, 1979: Proceedings: Third Annual Workshop on Meteorological and Environmental Inputs to Aviation Systems, 3-5 April 1979, NASA CP-2104/FAA-RD-79-49, Washington, DC, 183 pp.
3. Camp, D. W., and W. Frost, 1981: Proceedings: Fifth Annual Workshop on Meteorological and Environmental Inputs to Aviation Systems, 31 March-3 April 1981, NASA CP-2192, Washington, DC, 143 pp.
4. Camp, D. W., and W. Frost, 1985a: Proceedings: Meteorological and Environmental Inputs to Aviation Systems, NASA CP-2388, Washington, DC, 154 pp.
5. Camp, D. W., and W. Frost. 1985b: "An Aviation Meteorology Workshop", Paper presented at Second International Conference on the Aviation Weather System of the American Meteorological Society, 19-21 June 1985, Montreal, Quebec, Canada.
6. Camp, D. W., W. Frost, J. W. Connolly, J. H. Enders, and J. F. Sowar, 1980a: Third Annual Workshop on Meteorological and Environmental Inputs to Aviation Systems, Bulletin American Meteorological Society, 61, 25-29.
7. Camp, D. W., W. Frost, J. W. Connolly, J. H. Enders, J. F. Sowar, E. M. Gross, and A. R. Tobiason, 1980b: Fourth Annual Workshop on Meteorological and Environmental Inputs to Aviation Systems, Bulletin American Meteorological Society, 61, 1628-1633.
8. Camp, D. W., W. Frost, E. M. Gross, J. F. Sowar, and A. R. Tobiason, 1981: Summary Report of the Fifth Annual Workshop on Meteorological and Environmental Inputs to Aviation Systems. Preprints, International Conference on the Aviation Weather System (Montreal), AMS, Boston, MA, pp. 233-238.
9. Frost, W., and D. W. Camp, 1978: Proceedings: Second Annual Workshop on Meteorological and Environmental Inputs to Aviation Systems, 28-30 March 1978, NASA CP-2057/FAA-RD-78-99, Washington, DC, 252, pp.
10. Frost, W., and D. W. Camp, 1980: Proceedings: Fourth Annual Workshop on Meteorological and Environmental Inputs to Aviation Systems, 25-27 March 1980, NASA CP-2139/FAA-RD-80-67, Washington, DC, 275, pp.

11. Frost, W., and D. W. Camp, 1982: Research Areas Relative to General Aviation Weather Problems. Paper presented at AIAA 20th Aerospace Sciences Meeting, Orlando, FL, 11-14 January 1982, 12 pp.
12. Frost, W., and D. W. Camp, 1983: Proceedings: Sixth Annual Workshop on Meteorological and Environmental Inputs to Aviation Systems, 26-28, October 1982, NASA CP-2274/FAA-RD-83-67, Washington, DC, 148, pp.
13. Frost, W., D. W. Camp, J. W. Connolly, J. H. Enders, J. F. Sower, and H. L. Burton, 1979a: Second Annual Workshop on Meteorological and Environmental Inputs to Aviation Systems. Bulletin American Meteorological Society, 60, 38-45.
14. Frost, W., D. W. Camp, J. H. Enders, J. F. Sower, and J. W. Connolly, 1979b: Survey of Meteorological and Environmental Inputs to Aviation Systems. Paper presented at the WMO Technical Conference on Aviation Meteorology, Geneva, 5-9 November 1979, 30 pp.
15. Miller, R.G., 1987: "Comparative Verification Between GEM and Official Aviation Terminal Forecasts", NASA CP-2498.

SECTION II
INTRODUCTION AND WELCOME

INTRODUCTION AND WELCOME

Dr. Walter Frost

Welcome to the Eighth Annual Workshop on Meteorological and Environmental Inputs to Aviation Systems. We welcome our newcomers. There are several new faces, as well as many of the “oldtimers”, so to speak, who are back with us. We appreciate your coming. I would like to begin the workshop by asking Dr. Ken Harwell, who is the Dean of The University of Tennessee Space Institute (UTSI), to come forward and welcome you here.

Ken is an Aeronautical Engineer who graduated from California Institute of Technology, completed some work at Auburn University, then joined us here as a professor and became our Dean a few years back. He is doing a great job for the Space Institute.

Dr. Kenneth E. Harwell

It is my pleasure to welcome you to The University of Tennessee Space Institute. I know that many of you have been here several times before, so this is not a new treat for you. However, I know we have several new faces in the audience and we are very glad to have you. We hope that you will have an enjoyable stay, both professionally and socially. For those of you who are new, I would like to say a few words about the Space Institute, and I feel that this is a unique institution in this country. We are totally a graduate university, and our graduate programs are integrated into a very large research program. For example, in our academic program we have, essentially 45 full-time professors and 20 part-time professors who are mainly from the Arnold Engineering Development Center (AEDC). AEDC is, as many of you know, the free world's largest aerospace test facility. Virtually every military, as well as civilian, aircraft engine, aeropropulsion system (such as the NASA Space Shuttle models) and MX Mission are tested here. It is a very-well kept secret in Tennessee that we have this large concentration of high-technology. Most of you have heard of NASA Marshall Space Flight Center in Huntsville, but not many have heard about the efforts of the Air Force at AEDC.

The Space Institute was established in 1964, so we had our Twentieth Anniversary this year. We have approximately 500 students now. We have 82 who are supported by full-time Graduate Research Assistantships. These are people who work full-time on our research contracts and grants. We have approximately 275 students from AEDC, and a number of graduate students who commute from Huntsville and Nashville. We presently have 160 graduate students in a new program that some of you may be interested in. We started a new engineering management program two years ago which is delivered by video tape over the entire

state of Tennessee, with one graduate of the program in Washington, DC. We hired Dr. Merritt Williamson, who was the Dean of Engineering Management” in this country, to start our program which has been very successful to date. It is a unique program for the practicing engineer who is in a management situation.

I would like to again commend Walter for his efforts in organizing this workshop. As you know, along with the Organization Committee members, he has done an excellent job over the past few years on behalf of this workshop, as well as his work at the Space Institute in atmospheric sciences and programs related to aviation.

In addition to the Atmospheric Science Division, we have a Flight Research Center at the Tullahoma Airport and other work going on in areas related to topics that you will be looking at. I hope you will take advantage of your visit here to talk with our faculty and see some of our laboratories. We have two centers of excellence here. One is presently funded by the Federal Government at approximately \$6.8 million per year in the fossil energy area. It is a coal-fired flow facility (magneto-hydrodynamics direct power conversion), and secondly, we have a new center for laser applications which is funded by the state with a budget of about \$2 million per year. The Space Institute is growing rapidly, with our budget increasing by about 42% in the past two years, which is very significant. We have also gained about \$2 million in new research equipment, with about \$600,000 of that coming from the state of Tennessee and the remainder being raised by our faculty.

I would like to express my appreciation to NASA Marshall and, in particular, Dr. George McDonough, and to Dr. Jim Blair who is representing him here today, for co-sponsoring this workshop. We are happy about the joint cooperative arrangements we have with NASA Marshall as it has been a very productive association over many years. Jim, I would like to express our thanks, again, for helping sponsor this workshop.

If there is anything that I can do to help make your stay any more beneficial, please let me know. My office is right next door to the auditorium.

Dr. Walter Frost

One thing Ken did not mention is that it is through his energies and drive that the Space Institute is growing in the manner that it is.

As Ken pointed out, our co-sponsor/co-host is our neighbor, NASA Marshall Space Flight Center, and to welcome you here on behalf of the Marshall Space Flight Center, we have Dr. James Blair. Jim is Deputy Director of the Science Dynamics Lab at NASA Marshall Space Flight Center and has been there since

1963 after working in the aircraft industry at General Dynamics, Fort Worth. He has an excellent education having an electrical engineering degree from Vanderbilt, in Nashville, Tennessee, and a degree in electrical engineering from The University of Tennessee. We are happy that Dr. Blair had the time to come here and welcome you to the workshop.

Dr. James Blair

I would like to bring you greetings and welcome from Marshall Space Flight Center and to thank Ken for his words, also. We are glad to be neighbors of UTSI. We are glad to see that we have such a good turnout today. We are also pleased to co-sponsor this workshop, and are proud to have been associated with this workshop and its accomplishments since its inception. The importance of your goals and subject matter is self-evident, and I would like to wish you continued success in your endeavors.

Any large, complex system has, as its lifeblood, information flow. Certainly all of you here today represent a large complex system from multiple organizations, technologies, bodies of knowledge, science, academic institutions, and operations that represent complex hardware/software systems, and communications is the lifeblood of this system. The enhanced communications, which is the purpose of the workshop, is what enables us to work toward the final goal of increased air safety. I would like to echo my boss, Dr. George McDonough, who has spoken to this group on a previous occasion, when he said that he was a frequent airline passenger (as we all are) and glad that there is a group such as this to address the types of problems and aim toward the goals of air safety. I would like to wish you well in your deliberations this week and look forward to another successful workshop.

SECTION III
OVERVIEW PRESENTATIONS

AUTOMATION OF SURFACE OBSERVATIONS PROGRAM

Steve E. Short
National Weather Service

Surface weather observations are fundamental to essentially all meteorological services. Observations are necessary in order to make accurate forecasts and warnings and to support aviation operations. For example, the National Weather Service (NWS) currently issues about 500 airport terminal forecasts three times a day, and NWS meteorologists also provide real-time weather information and short-range forecasts for use in pilot briefings and to aid pilots and air traffic controllers.

A complete surface aviation observation provides precise information on weather conditions at and near the Earth's surface, and is taken and recorded at least hourly. The parameters observed typically include temperature and dew point, pressure, wind speed and direction, precipitation type and amount, visibility, and cloud cover and height.

While the NWS provides the core of the nation's weather services, other federal agencies—primarily the Federal Aviation Administration (FAA) of the Department of Transportation (DOT) and the Air Weather Service (AWS) of the Department of Defense (DOD)—routinely take surface weather observations at many locations. Together, the three agencies expend about 1,020 staff years annually on these activities at nearly 1,000 locations across the country.

At present, surface observing methods are still largely manual and labor-intensive. Approximately 1,200 NWS employees participate in taking surface observations at about 260 locations. Other routine services provided by these employees typically include issuing local weather statements, forecasts, updates, weather radio broadcasts, and pilot briefings. In addition, radar or upper-air observations are also frequently involved. Over the past decade, personnel ceiling restrictions, combined with the need to provide improved services, have severely strained staff capabilities. During periods of bad weather, the need for special observations increases dramatically, and station staff is stretched thin. Severe weather conditions such as hurricanes, tornadoes, severe thunderstorms, high winds, and winter storms do result in even greater demands placed on the limited available staff.

Through the nationwide implementation of Automated Surface Observing Systems (ASOS), this situation can be improved. In addition, advances in Doppler radar (and in information systems which integrate complex radar, satellite and surface data sets) provide the opportunity for significant service improvements. Agency modernization plans envision broad use of these technologies coupled with

organizational changes and an enhancement of the workforce skill mix to use these new technologies fully. These modernizations are planned to be in place by the early 1990's. ASOS will contribute to this modernization initially through substantial reduction in the labor intensity of the observing function. This reduction in observing work load will permit significant conversion of the field work force to the professional level, and subsequently relieve the constraint of fixed staffing locations, especially at airports.

Objective and Benefits

The program objective is to effectively automate the surface weather observing function. By employing recent technology advances, the NWS will implement a system which can handle all routine observing and record-keeping chores, and which should reduce staff time now spent in taking observations by greater than two-thirds. ASOS will then enable a) redirection of staff to other services, b) flexibility in future staffing and service consolidations, and c) an upgrade in workforce professionalism.

In addition, the systems will contribute to improved aviation safety and better forecasts and warnings, and specifically will

- Operate full-time, 24 hours a day—especially important at part-time stations
- Produce better night observations—particularly in the areas of visibility and sky conditions
- Standardize observation of the visual elements (i.e., visibility and sky condition)
- Provide a continuous weather watch and rapid alert of significant weather changes
- Allow for remote maintenance monitoring
- Replace existing aging equipment

Application of ASOS

Two ASOS capability levels are planned. The first is a Basic-level System which will automatically observe the weather parameters essential for aviation operations and will operate either with or without supplemental contributions by an observer. The second is a more fully automated, Stand-alone System which will observe and report the full range of weather parameters and will operate primarily in the unattended mode.

Approximately 250 systems are planned to be in operation around the end of the decade at nearly all current NWS primary observing sites in the United States. Initially, most of these will be Basic Systems, which will be attended when the facility is open, and potentially at other times by cooperative observers. Stand-alone Systems will at first be limited to a small number of critical locations where observer attendance is impractical. Ultimately, most systems will be enhanced to a full-automation level as appropriate future key sensors become available. These systems may also be augmented to a small degree, if necessary.

When initially deployed, these systems will generate the standard hourly and special long-line transmitted weather observations, as well as provide continuous weather information direct to airport users, e.g., weather office and air traffic control tower.

At a later stage, as other modernization programs of the NWS and FAA are completed, quasi-continuous weather information from these systems will also flow directly into the NWS Warning and Forecast Offices and FAA Air Control Facilities from systems within their areas of responsibility.

Interagency Aspects

The ASOS is an NWS program. However, as the NWS, FAA and AWS (as well as other Defense components) have interdependent observing programs, the introduction of automation needs to be fully coordinated. Thus, an interagency mechanism has been established to coordinate observing policy, equipment development, and acquisition efforts among the three agencies. This mechanism, known as the Joint Automated Weather Observing Program (JAWOP), is to ensure that observations remain fully interchangeable between agencies and that, wherever appropriate, costs will be reduced by collaborative sensor developments or selected equipment procurements.

Observing Process—Manual versus Automated

Today's method of taking surface observations is still primarily manual and largely unchanged from the earliest days of aviation. Using sensors of varying sophistication, the observer personally views and records the indicated values. The observer then often calculates additional weather parameters, applies correction factors, converts data to proper units, etc. The observer then codes the observation into the proper format and manually enters it onto one or more communications systems. This sequence is repeated at least hourly at most locations, with additional "specials" taken whenever significant weather changes occur. Often, the observer must also communicate with the local control tower to ascertain tower visibility and to provide air traffic controllers with the current observation.

The Basic ASOS will relieve the observer of most of this process. The data will be automatically collected, checked, formatted, displayed and transmitted. The system will also continuously monitor weather conditions. The observer need only check for unusual and some specific conditions to determine if necessary to edit the automatically prepared observation. The Stand-alone System will usually operate completely in an unattended mode, performing the same operations as the Basic System, but incorporating additional sensors to identify and report on selected present weather elements as well. Figure 1 illustrates both the manual and automated surface weather observation.

Technology Background

Development of automated observing systems has been under way for a number of years. Research on techniques and development of automation to determine the traditionally visual elements of sky conditions, visibility, present weather, and obstructions to vision have resulted in significant improvements in automation capability. With recent advances, it is now possible to automate surface observations almost completely, providing for more standardized and objective reporting and removing most human-induced variations.

The feasibility of automation of most weather elements (excluding present weather) has been conclusively demonstrated by the Aviation Automated Weather Observing Systems (AV-AWOS) experiment conducted in 1978. This joint FAA/NWS project used a minicomputer-based system with conventional surface-type sensors, an array of ceilometers and visibility sensors, and innovative data processing techniques. This system operated side-by-side with weather observers for four months, and confirmed that the technology exists to automatically provide the minimum set of weather elements needed to satisfy aviation interests and minimal forecast requirements.

System Requirements

ASOS is to be a flexible and modular system capable of being deployed in various configurations and able to function with or without the attendance of an observer. The system is required to operate continuously with high reliability under varied and sometimes extreme weather conditions. It must be capable of providing data in multiple reporting codes and interfacing with existing and future weather sensors in differing combinations, as well as with various communications means.

CURRENT MANUAL METHOD

Measured: (m) Observed: (o)

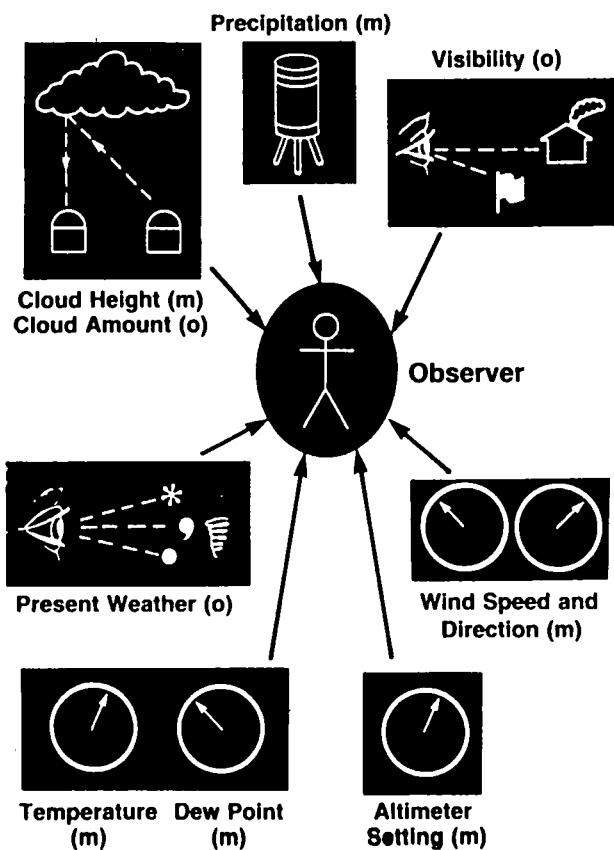

AUTOMATED SURFACE OBSERVING SYSTEM (ASOS)

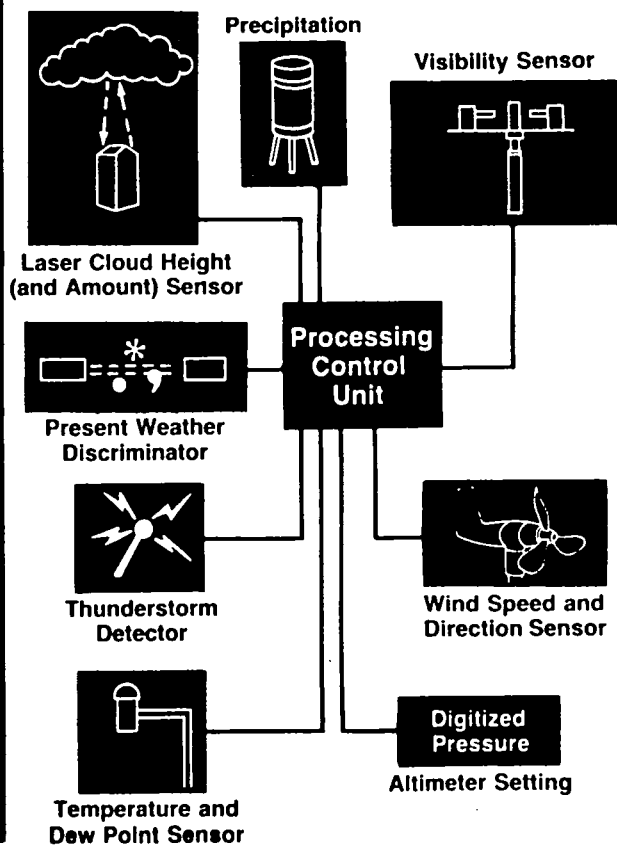

Figure 1. Surface Weather Observation.

Figure 2 illustrates the ASOS system concept, and Figure 3 illustrates a typical airport installation.

A. Automated Capability Levels

Specific configurations will vary depending upon whether the operation is unattended, attended by observers who provide a minimal level of information, or fully automated with a more extensive set of sensors for use as a Stand-alone System.

In all cases, the system will handle all the clerical tasks of local archiving, maintaining the observer's log and summaries, and formatting in various codes for distribution. The system will stay continuously on duty to detect and report significant weather changes as they occur, thus providing a continuous weather watch (which is not now possible) at NWS sites.

B. Basic System - This system will operate in two modes:

1. Unattended - This system will be configured to automatically observe the essential weather parameters needed for aviation operations and most forecast operations. Typical observed parameters will be

- Wind speed and direction, gusts, squall, wind shift, etc.
- Temperature and dew point
- Pressure characteristics
- Visibility conditions (to 8 miles)
- Limited present weather (e.g., freezing rain, precipitation occurrence, thunderstorm detection)
- Precipitation accumulation
- Sky condition (up to 10,000-12,000 feet)

The entire observation will proceed automatically, with only occasional checks by on-site personnel to verify proper operation. The observation generated by this basic, unattended system will also include selected automatically generated remarks.

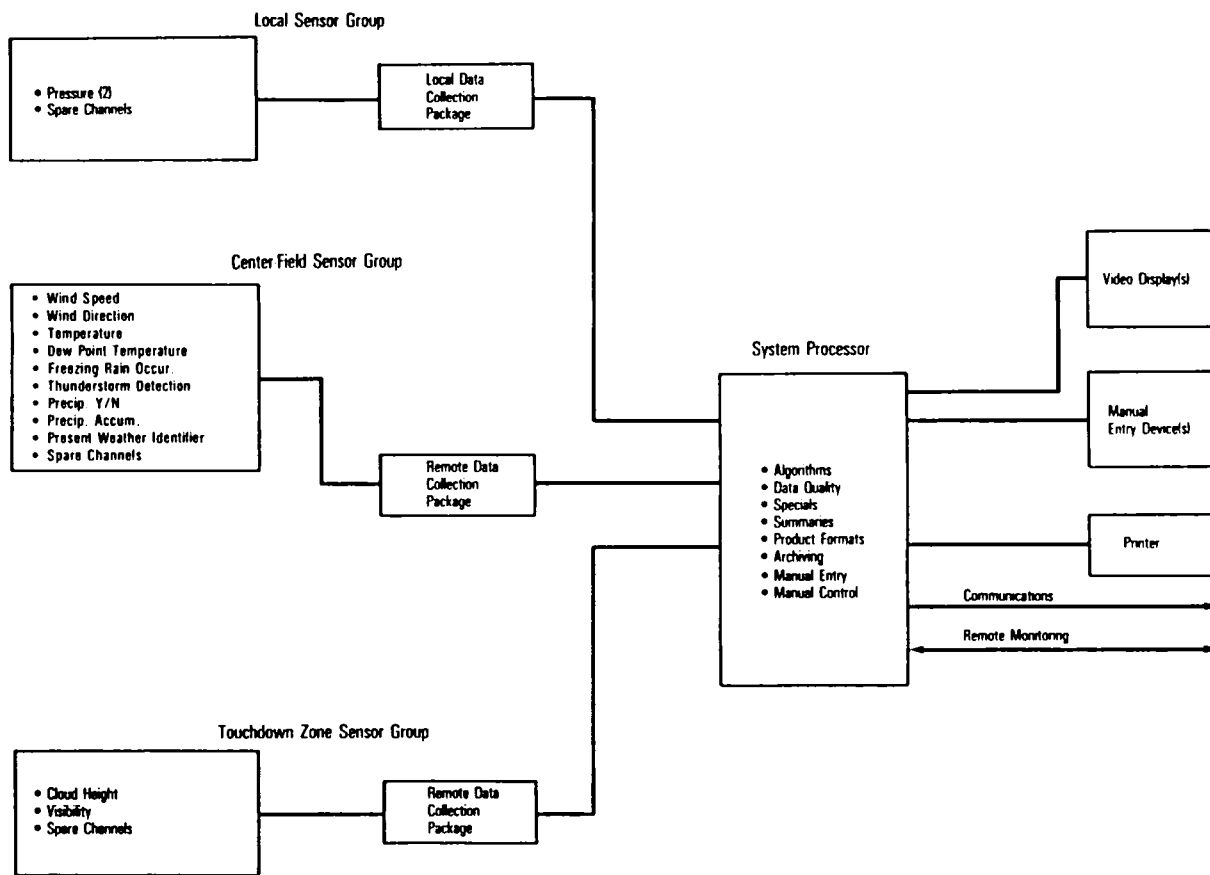

Figure 2. Typical ASOS Block Diagram.

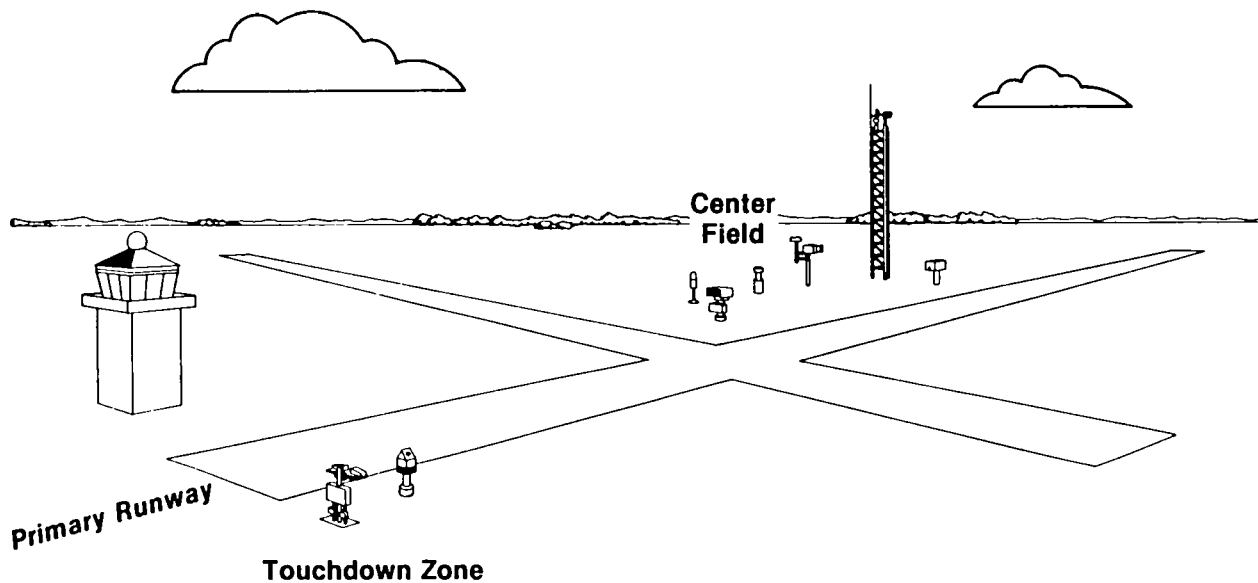

Figure 3. Typical Airport Installation.

2. Attended - The attending observer will add to the observation of the basic system by providing additional selected information on present weather and adding necessary additional remarks. This input will be via manual entry keyboard, and requires little more time than that needed to maintain an awareness of on-site weather. At stations staffed part-time, the system will continue to operate after hours in the unattended mode to provide continuous 24-hour observations.
- C. Stand-alone System - This system is designed to operate in an unattended mode to automatically observe and report the full range of weather parameters that can be automated. This requires additional sensor and processing capabilities beyond that of the basic system, namely:
- A present weather sensor (e.g., Laser Weather Identifier) for detection and discrimination of precipitation type and character
 - Extra ceilometers and visibility sensors (at selected locations as necessary to recognize and report non-homogeneous conditions)

High system reliability and data quality assurance are essential since this stand-alone system may have neither an observer nor a local repair technician.

D. System Functions

The major functions of ASOS are grouped into four areas: 1) data collection, 2) processing, 3) product distribution, and 4) system control. These functions are described as follows:

1. Data Collection - Uses a variety of sensors to measure weather elements and provides the sensed data for processing.
2. Processing - Performs a variety of preprocessing functions including a) conversion of sensed data into specific weather parameters, b) monitoring data quality to identify erroneous, questionable, or incomplete data, c) formatting the observed parameters into standard observation products for display and communication, d) archiving of selected observations and system status information for subsequent retrieval, and e) monitoring its own performance via periodic throughput testing and diagnostic capabilities.

3. Product Distribution - Distributes or communicates data, observations, summaries, and status information to a wide variety of users. Distribution methods include local and remote displays (e.g., tower, weather office), automatic dial-out or direct connection to long-line distribution circuits, and dial-in for inquiry and remote monitoring.
4. System Control - Provides three types of control: 1) Manual Entry, which allows an observer to add data, edit, or override the automatically generated observation; 2) Inquiry Functions, which allow an operator to review previously distributed products; and 3) System Control Functions, which allow a local or remote operator to monitor or change system status, configuration, or constants, and to initiate special system functions.

Program Phases

The Automation of Surface Observations Program has been structured into four phases:

- Development
- Demonstration
- Production System Acquisition
- Operational Implementation

Figure 4 depicts the program phases and general schedule.

Development Phase

This phase, presently under way, consists of development and refinement of sensors and algorithms. Most of the sensors and algorithms necessary for operation of an attended Basic System are currently available. Some further development and algorithm refinements are ongoing to reduce cost and the remaining technical risk, as well as attain the highest possible performance level. Development of a present weather sensor for the stand-alone, unattended operation is still under way. In addition, selected currently operating but obsolete sensors are being replaced with modern sensors that will be fully compatible with future needs of automation (e.g., hygro- thermometer, ceilometer).

The objective parameters (i.e., wind speed and direction, pressure, temperature, dewpoint, rainfall, and occurrence accumulation) can be readily automated. The sensors for these are currently available, as are most of the necessary processing algorithms.

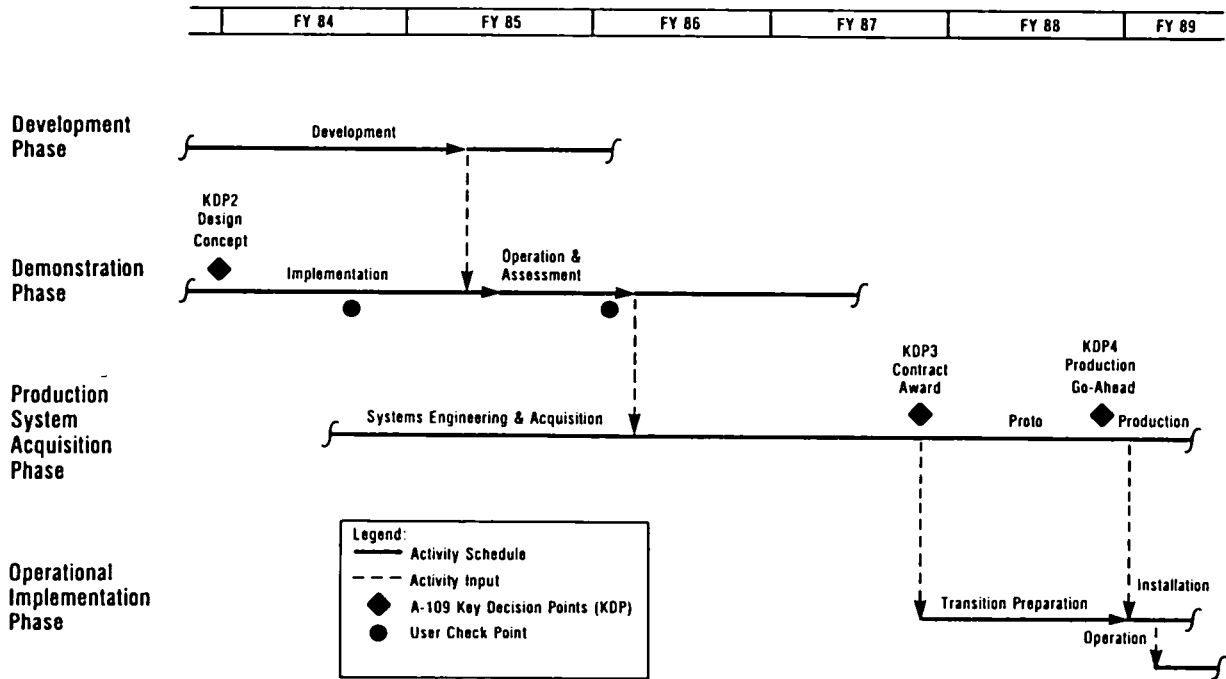

Figure 4. Program Phases and General Schedule.

Algorithms are ready for most cloud parameters (e.g., cloud height and amount, ceiling height, variable ceiling, and variable cloud amount) as well as for most visibility parameters (e.g., visibility, variable visibility, and sector visibility). However, refinements to these algorithms are necessary and will be developed in conjunction with the demonstration. Laser ceilometers are becoming commercially available and should ultimately be capable of monitoring all of the necessary cloud parameters. This sensor is especially critical to the automation program, and NWS is actively engaged in the acquisition of a next generation ceilometer which should, after development, testing, and necessary refinement, become suitable and available for automation by about 1987. Both forward-scatter and backscatter meters are proven technology for monitoring visibility and will adequately serve for the visibility measurement.

Algorithms are also available for monitoring thunderstorm occurrence and freezing precipitation. Commercially available sensors for these parameters are available; however, sensor improvements will most likely be required as field testing continues.

A. Near-term Development

Relatively low-risk, near-term development (e.g., two to four years) is needed for the sensors and algorithms that report mixed precipitation, thunderstorm location and movement, and water equivalent of snow.

The Laser Weather Identifier (LWI), which has undergone testing for several years, can detect and identify pure states of rain, snow, and hail. The LWI and its associated processing algorithms are expected to be ready for the initial ASOS procurements. An alternative approach to the LWI is also under development in order to provide additional assurance of attaining a satisfactory sensor. This is the Light Emitting Diode Weather Identifier (LEDWI). This device has less-complicated electronics, optics, and light source. This single-ended sensor is anticipated to have advantages over the LWI in terms of production cost, installation, and maintenance. Prototypes of the LEDWI are being fabricated for initial testing during the winter of 1985-1986. After this preliminary test, the decision will be made whether to further pursue the LEDWI alternative.

A lightning location sensor which will monitor thunderstorm activity should be ready soon. Deployment of ASOS with a single, on-site sensor having adequate range and heading resolution should yield an effective solution for surface observing. Alternatively, the existing and expanding networks of lightning direction-finding capability operated

by other agencies (using centralized processing) may be expanded into an almost nationwide system, which has potential to provide the necessary capability in lieu of the site-specific approach. However, further research is necessary before the final decision on the approach for lightning detection will be made.

Relatively low-risk development should yield sensors and algorithms adequate for reporting precipitation occurrence and amount, and thunderstorm location. However, final refinements and development, testing, and acceptance will require a few years.

B. Longer-term Development

The need for additional development or refinement in the detection and characterization of present weather parameters is still required. Much of this work will be identified and begun within the Demonstration Phase (as part of the Climatic Test-bed Project). Specific algorithm refinements to be undertaken include capability for nonhomogeneous cloud height or cover and low-visibility conditions, as well as development of specific criteria for locations requiring multiple sensors.

C. Standards Development

Appropriate siting of sensors is essential to ensure that their measurements truly reflect the meteorological conditions. An interagency task group has been established to develop and coordinate necessary standards. This group, the Task Group on Surface Instrumentation Standards (TG/SIS), was established to develop appropriate national standards for sensor siting at airports (as well as algorithm standards and certification policy and procedures). This group will review existing guidelines and standards and reconcile individual agency criteria. The TG/SIS is under the Interdepartmental Committee for Meteorological Services and Supporting Research.

Demonstration Phase

The demonstration has two thrusts. Systems with current sensors and algorithms will function in a quasi-operational environment in the Kansas Pilot Project. Systems intended for use in algorithm and sensor testing and refinement will be deployed in the Climatic Test-bed Project. Delivery of the systems in early 1985 will be followed by operation and ongoing assessment through 1986. (A commercial system using similar sensors and many of the NWS algorithms has recently been

tested and certified for official use by the municipal airport at Lynchburg, Virginia.

A. Kansas Pilot Project

The Kansas Pilot Project will provide further experience in operations and maintenance of automated systems and will be used to assess the impact on observing operations as well as to determine the most appropriate level of automation. In addition, selected forecast operations will be conducted to assess the adequacy and advantages of automated observations. The project will use a state-wide network of six observing stations exposed to a wide variety of weather (e.g., freezing rain, thunderstorms, and dense fog), as well as frequently occurring changes in the weather. All levels of system capability will be evaluated. The stations will be collocated with existing operations: 1) the Automated Meteorological Observing System (AMOS) at Elkhart; 2) the Weather Service Offices (WSOs) at Dodge City, Wichita, Concordia, and Goodland; and 3) the Weather Service Forecast Office (WSFO) at Topeka. Location of automated systems at current NWS observing sites permit comparisons of quality, timeliness, and content between the two observing methods.

Preparation for the Kansas Pilot Project is well under way, and installation is currently in progress, with operations starting by May 1985 and continuing for at least 18 months. In addition, an ASOS unit is being placed in the FAA tower at the Kansas City Municipal Airport for use by the FAA in assessing workload impact on air traffic controllers in augmenting the automatically generated observation.

B. Climatic Test-beds

The Climatic Test-bed Project will deploy automated observing systems in four other regions with distinctly different climates: 1) subarctic (Fairbanks, AK); 2) mid-latitude temperate (Dulles Airport, VA); 3) maritime (San Francisco, CA); and 4) semitropical (Daytona Beach, FL). This development project will serve to uncover weather-related factors that affect sensors and algorithms. Figure 5 illustrates these locations.

Production System Acquisition Phase

This phase covers the production system planning, engineering, procurement, and manufacturing, as well as operations and maintenance planning and provision-

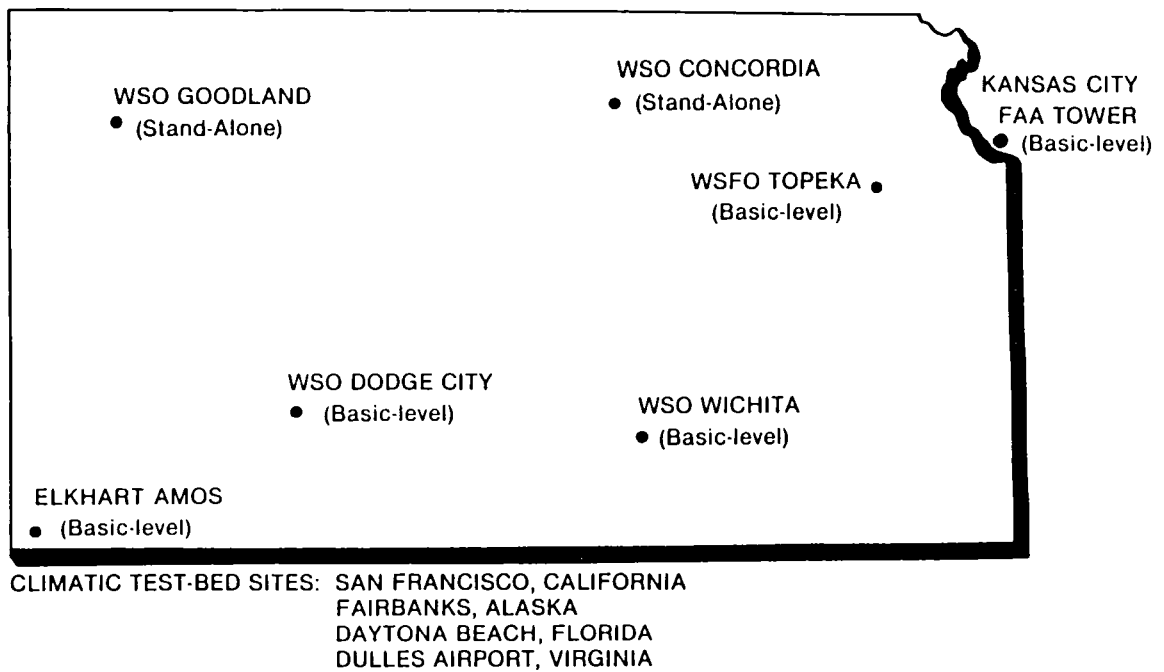

Figure 5. Kansas Pilot Project

ing. This phase will start sufficiently early to permit timely deployment of the production systems, yet allow for assimilation of development and demonstration results into the production contract effort. Final engineering will be completed for communications interface (with NWS's current automated weather information system initially; and, subsequently, to enable quasi-continuous data flow into future systems), display, archiving and system integration planning, and final system design. Rigorous testing and evaluation will be conducted throughout this phase. Support planning and provisioning will also be completed for operations and maintenance training and preparation necessary for the nationwide transition into automated observing operations. Initial efforts leading to production systems will begin with engineering planning in 1985. By late 1986, results from the demonstration effort will be integrated into the equipment and services specification, along with the results of final engineering and support planning. The production system award is planned for late FY 1987. Prototypes will be tested leading towards the final production go-ahead targeted for FY 1988.

Operational Implementation Phase

The operational implementation phase involves installation (including site survey and facilities preparation work), site and system acceptance and activation, and the transition to automated observing. The Operational Implementation Phase will start in 1988 with site preparation and operations and maintenance training. Systems will be installed and operated beginning in mid-to-late 1988, with completion of this phase planned for the early 1990's.

BRACKNELL METEOROLOGICAL OFFICE

Colin R. Flood
Bracknell Meteorological Office
Bracknell, Berkshire, England

Introduction

This presentation will be more of a “view” than an “overview” and will basically cover the Bracknell Model, the products, and the services provided by the Bracknell Meteorological Office. First of all, Bracknell is situated approximately 40 miles west of London (quite close to Windsor Castle).

Last year Bracknell became one of the world centers for civil aviation; it is also a regional center. As far as things in the United States (U.S.) go, that change may not have made very much difference, but for Europe, it was quite a significant change. There are two Numerical Forecast Centers very close in the United Kingdom (UK). One, of course, is the Bracknell Meteorological Office; the other is the European Center for Medium Range Weather Forecasting, which is a consortium of about 25 European countries that have set up a center purely for numerical modeling. The latter provides no forecast services; it is purely for numerical model guidance aimed particularly at the medium-range period (4–10 days). Their model is run once a day and has a late cutoff time ($\sim T+11$); the products are very good, but aimed very much toward the medium-range. The Meteorological Office at Bracknell is the National Weather Service for the UK. It runs a global model twice a day with a much earlier cutoff and with much more forecasting for shorter periods ahead (up to 36 hours and up to 6 days). As far as civil aviation goes, it is Bracknell which is providing the products.

World Center and Regional Centers Products

As mentioned above, the global model is run twice a day. Taking into account the standard range of observations in our analysis, we provide the following data: surface and radiosonde; aircraft reports (these are particularly important in the data-sparse areas); satellite soundings and wind; followed by the intervention from a human forecaster. The human forecaster has the opportunity to look at those observations, input interactive quality control graphics, and make sure the analysis from which the forecast starts is as good as it can be. The analysis is every six hours with temperatures and winds.

The forecast model is a global model run on a 150 km grid with 15 levels (a good resolution for a global model). Therefore, there are about 1/3 million grid points in that model; yet, reproducing in that forecast model, a 24-hour forecast

takes four minutes. That is the power of the Cyber-205.

Backup is very important as far as running models is concerned. The most important thing is that the backup is transparent to the user; i.e., the user of the products sees those products exactly the same as whether they are the real thing or whether they have been coupled together with our backup arrangements. Our backup arrangements are that every time we produce a forecast run (perhaps to 12 or 18 hours for aviation), we extend that forecast to produce identical products for 12 hours later. Therefore, we always have a forecast from the previous run to fall back on if we have problems with the next run. If necessary, we go back 24 hours, but before doing that, we would tend to use the products from the other World Center in Washington. Again, the products from Washington would probably be 12 hours in arrears.

The standard output from the global products are wind, temperature, height (standard levels), tropopause, and maximum wind (available $\sim T + 0430$). We run the model with a cutoff of $\sim T + 0320$, and the products output at 0430, twice per day. These products go out electronically to the airlines organizations such as SETA, and they also go out to the regional area forecast centers. The regional centers are responsible for turning those products into charts. Figure 1 is a forecast chart from the Bracknell Model on 6 March 1985 covering Europe, Africa and South America showing a marked trough in the wind flow. Besides providing products for civil aviation, products are also provided for military aviation. Figure 2 is an example of a series of forecast charts at different flight levels which go to the military center at Strike Command at High Wickingham. Unlike in the U.S., the services in the UK are provided from one center; therefore, the Meteorological Office at Bracknell provides the products for the Royal Air Force as well as the products for civil aviation.

Another task of the regional centers is to provide significant weather charts. In the U.S. there is one center in Washington, DC; thus, you may not see a difference between the World Center and the Regional Centers. In Europe there are three Regional Centers: one each in Bracknell, Paris and Frankfurt. These weather charts are produced every six hours by forecasters. We exchange products with the U.S. and the other European centers, so we have a good idea of what is going on. Figure 3 shows the areas for which the UK is responsible, for west-bound flights across the Atlantic. Much of our information for the U.S. is taken from products exchanged with Washington.

Short-Period Forecasting

When discussing short-period forecasting for particular air fields or routes over small areas, the man-machine mix becomes very important. The aforementioned

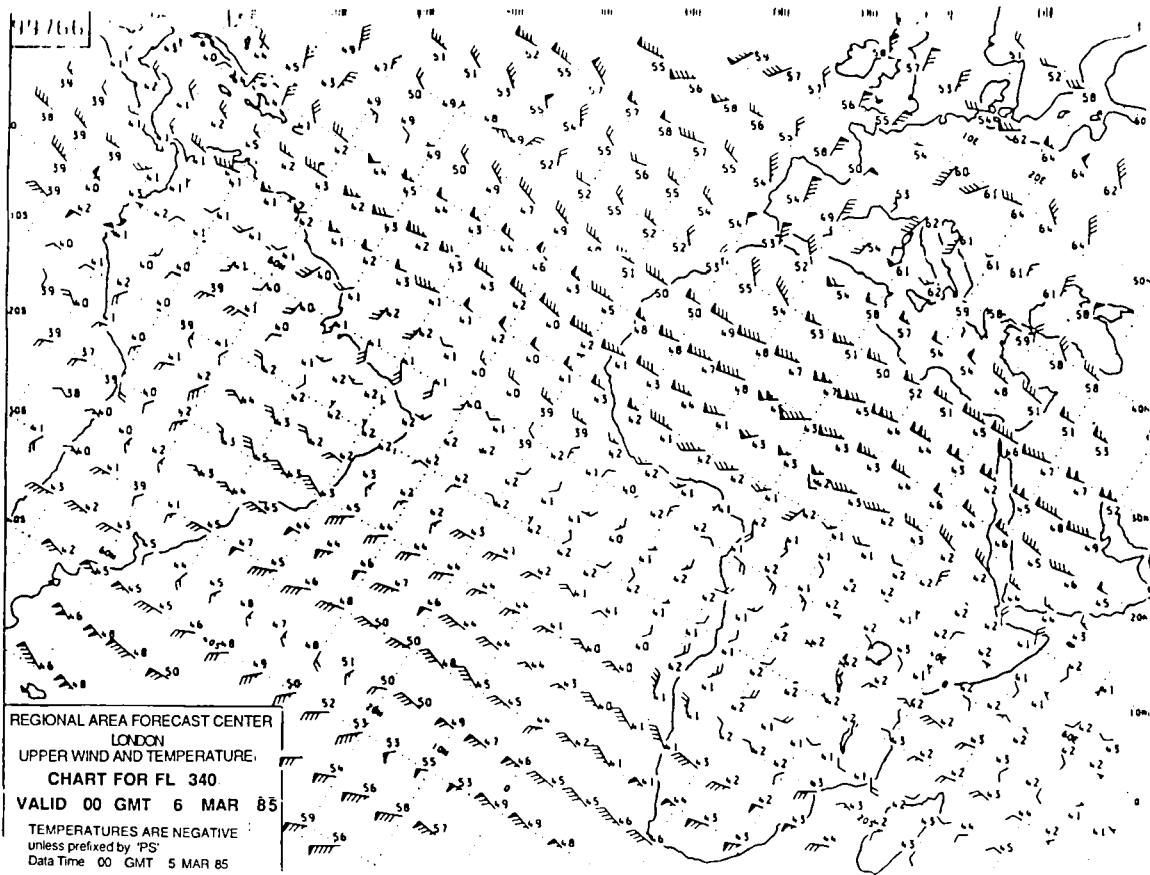

Figure 1. Forecast chart from the Bracknell model on 6 March 1985.

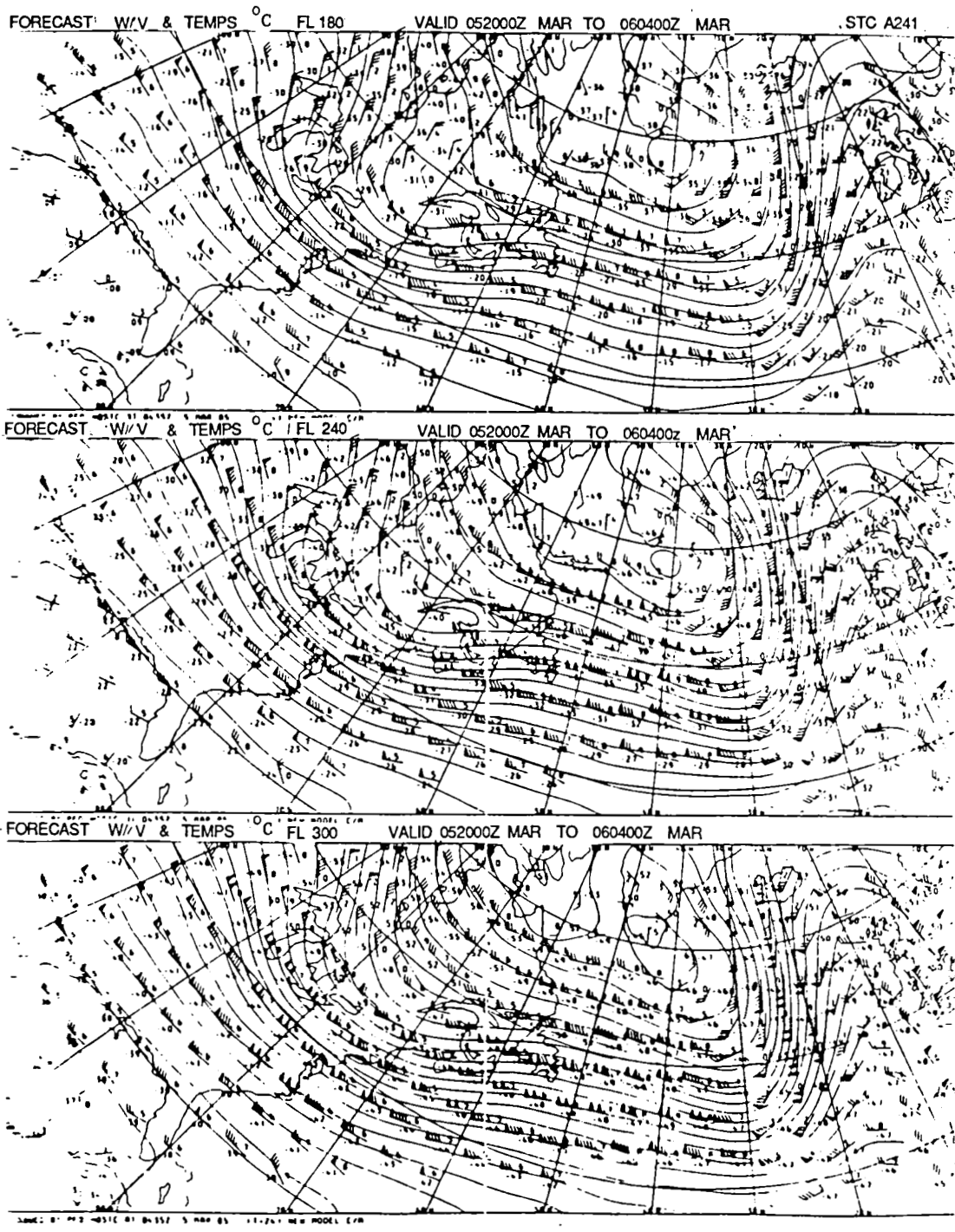

Figure 2. Example of a series of forecast charts at different flight levels.

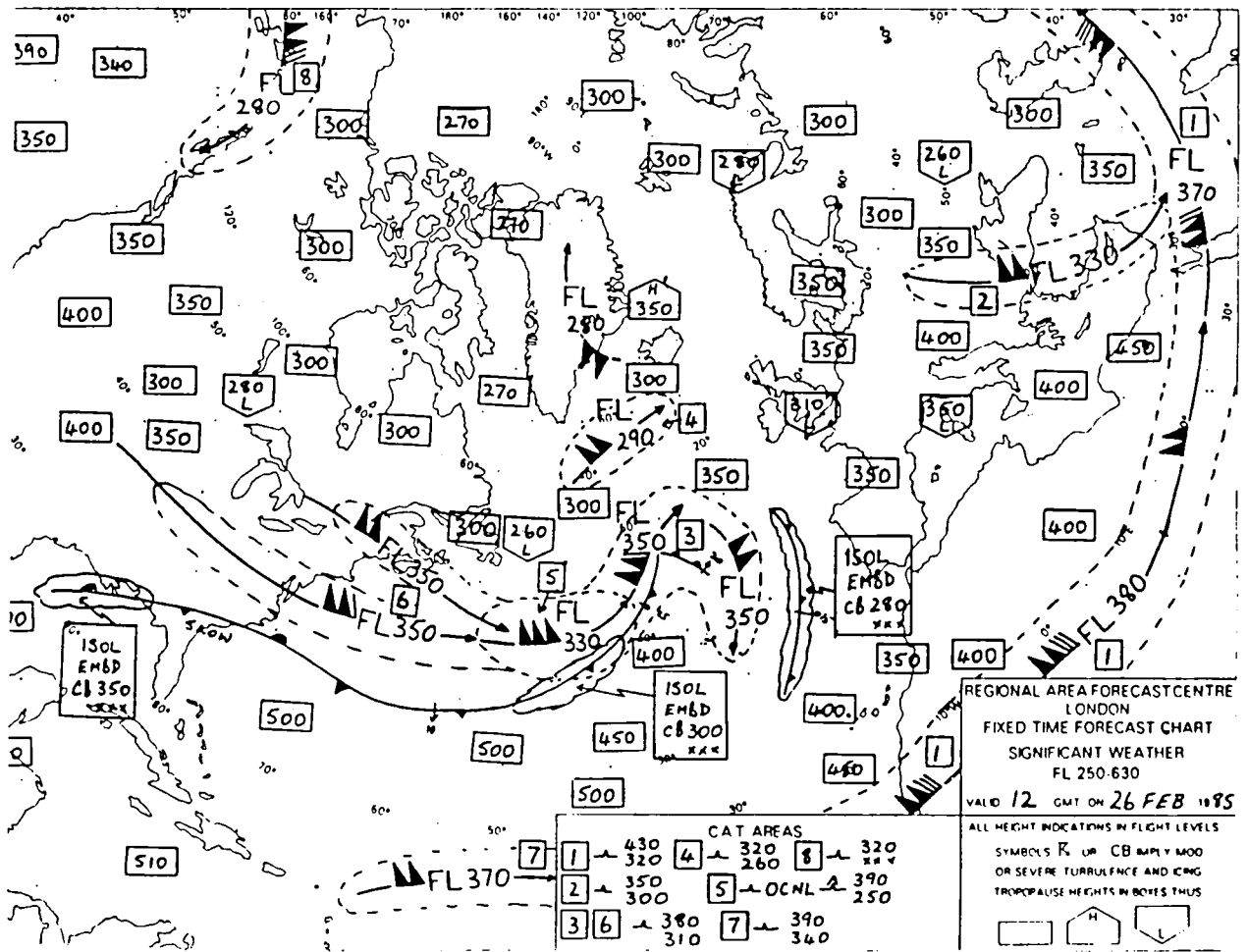

Figure 3. Areas for which the United Kingdom provides forecast services.

method of forecasting has been very much numerical-model dominated. Various experiments have been conducted to see if forecasters could improve on the upper-wind forecasts (e.g., across the Atlantic). The results were that it is very difficult to beat the numerical model, even giving the numerical model guidance to the forecasters. However, once into short-period forecasting, the man becomes much more important. The machine is still very important; thus, we have the man-machine mix using graphic devices which are clearly going to extend over the years to come. We can also think of interaction analysis and extrapolation techniques which have been explored quite significantly in the U.S. We would hope to learn more about these techniques which are very dependent upon good data for the covered areas. However, there is a question as to how far ahead these short-period extrapolations or forecasts can be produced, because the data are being entered only at particular levels and is not particularly helpful for a numerical model, which finds it quite difficult to adjust to data going in at, for instance, only the main flight levels. What is happening to the model at a level like 15,000–20,000 feet when many aircraft are flying much higher? Definite applications are needed, particularly for general aviation and for locations over the U.S., but they are not so essential for going across the Atlantic. There is still the question as to how far they can go. Six hours is promising, but I believe 12 hours is pushing it.

Small-scale models are being run in both the U.S. and the UK. We have a fine-mesh model which covers Europe, the Atlantic, and just into the U.S. We are also developing a mesoscale model which has a 15 km grid and covers quite a small area. It is 1/10 of the resolution of the global model, and it is producing rather interesting results. Figure 4 shows a forecast from that model for Brize Norton. The F/C indicates the forecast observations from the mesoscale model; the ACT indicates the actual observations for different hours. The first section in Figure 4 shows the forecast until midnight. More interesting is what happened after midnight, as is noted in the second section in Figure 4, showing the forecast to 06Z. Brize Norton went into fog at 0300 (with a visibility of about 200 yards), came out of fog a few hours later, then it began to rain about an hour later. This is illustrative not of what we can do now, but of what we may be able to do in the future with the mesoscale model.

In 1982, we made a transition from our 10-level model using the IBM 36195 to a 15-level model using the Cyber-205. The NMC is now going through the same phase. During that period, many tests were run between the old and new models, and Figure 5 shows these results. This was an 18-hour forecast produced in the summer of 1982 just prior to introducing the new model. The diagram on the left is the maximum wind forecast made by the 10-level model, and the diagram on the right is the forecast made by the 15-level model. The thick lines indicate the 100 kn isotach. The big difference can be noted by the 10-level model producing a complete envelope right around the ridge, and the 15-level model forecasting winds of up to

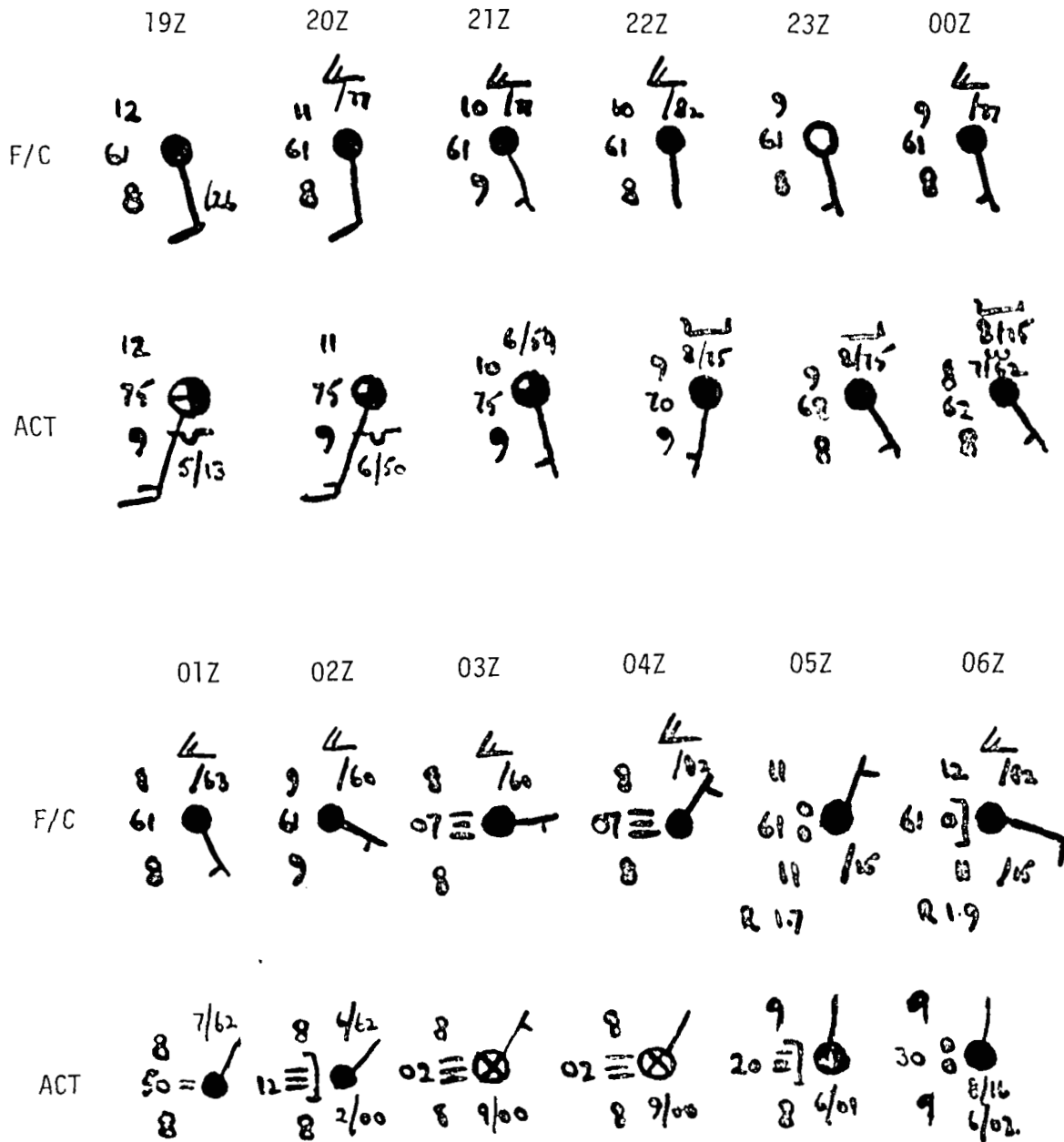

Figure 4. A forecast from the mesoscale model for Brize Norton.

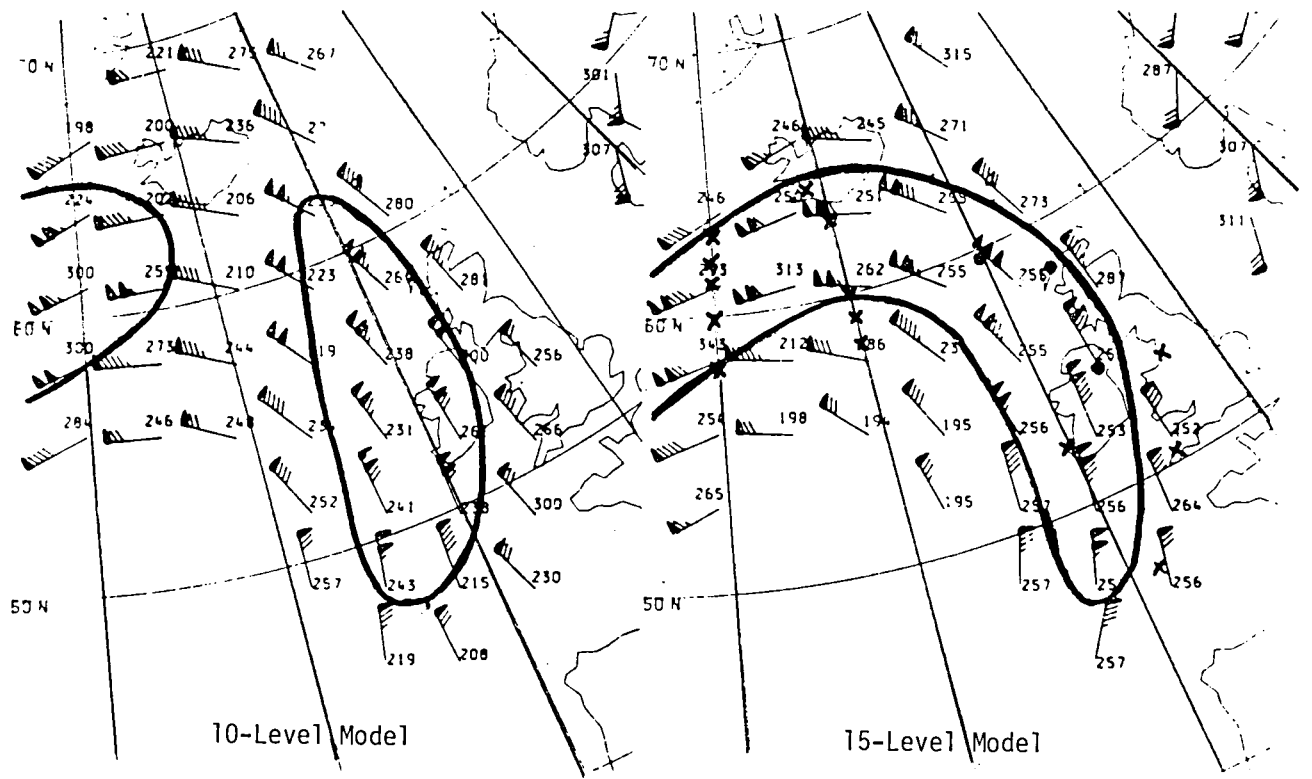

Figure 5. 18-hour forecasts from 00Z 30 August 1982.

150 kn compared with a maximum of about 120 kn. For verifying analysis, the x 's indicate aircraft reports of 100 kn or greater; so it is fairly clear that the 100 kn did indeed extend around the ridge. The \bullet 's indicate the radiosonde observations or aircraft reports of 150 kn. So, in the middle of that core, there were certainly winds of 150 kn. That is the type of improvement we have been noticing fairly typically since we transferred to our new model.

A great deal of verification work is done to see how good the models are. Figure 6 shows the 48-hour forecast of 500 mb height; regardless of the parameter, you can see the big drop in forecast errors over the period between 1966 to 1983. One axis shows the error in the model, and the other axis shows the period from 1966/67 (when the early models were introduced) to 1982/83, with the last one being in 1983/84. During the period of our 10-level model, forecast errors decreased gradually toward the large drop, shown by the circles, which indicates use of the 15-level model introduced in 1982. It is also interesting to note that the models improve during their life as improvements are gradually input to the system. The black circles to the right of the diagram on Figure 6 indicate the 72-hour forecast errors from the current 15-level model. They are about as good as the 10-level model forecasts were about five or six years ago.

In 1978, we began to verify against observations in lieu of against analyses for greater accuracy. Figure 7 shows the RMS temperature errors for an area covering Europe, the Atlantic, and eastern America from 1978 to 1984. The open circles are the 10-level model, and the full circles are the 15-level model, with 1982 being the transition year. Similarly for winds, Figure 8 shows the 24-hour RMS vector wind errors, 200 mb, down to about 14 kn, over the same area as in Figure 7. As a new model comes in, the figures get better; but equally, improvements are introduced during the course of the model. A big change was introduced into our model in December, which added a new parameterization. In fact, for January, which is normally one of our worst months because the jets are strong, the figure was 14 kn, which is the same as the whole of the average for 1984. The figure for February was 13 kn. The year 1985 appeared to be a good year, also.

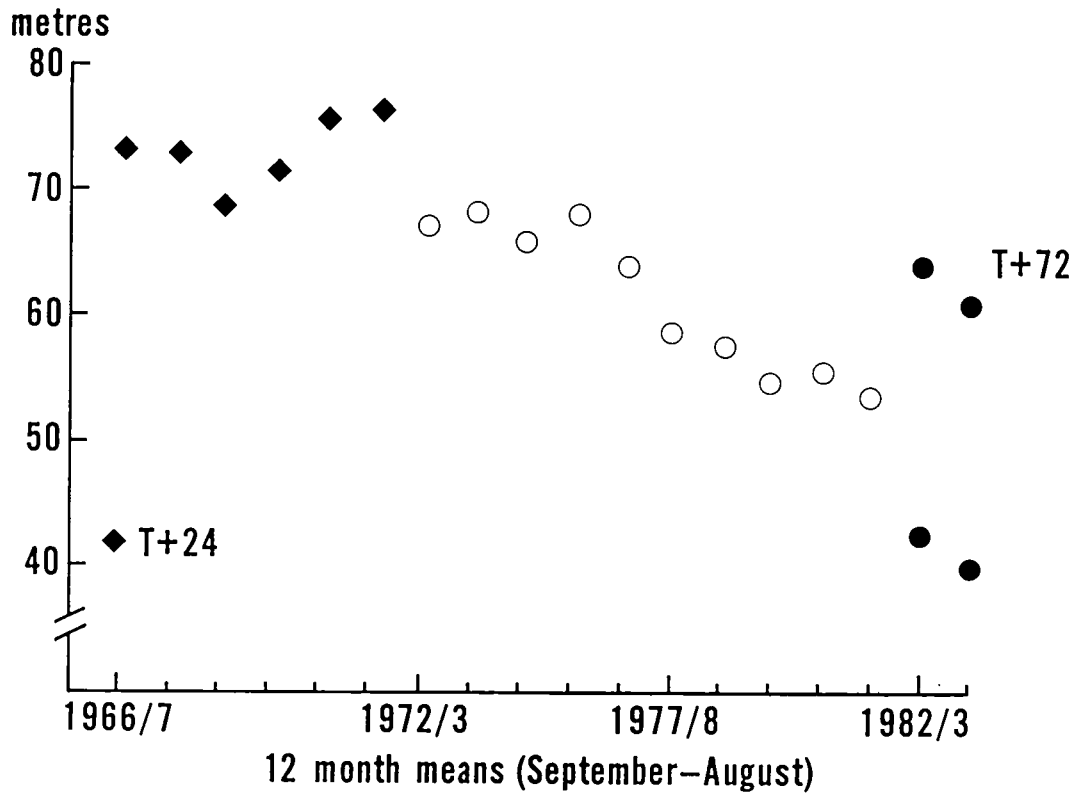

Figure 6. The 500 mb RMS height errors compared with model forecasts at T + 48.

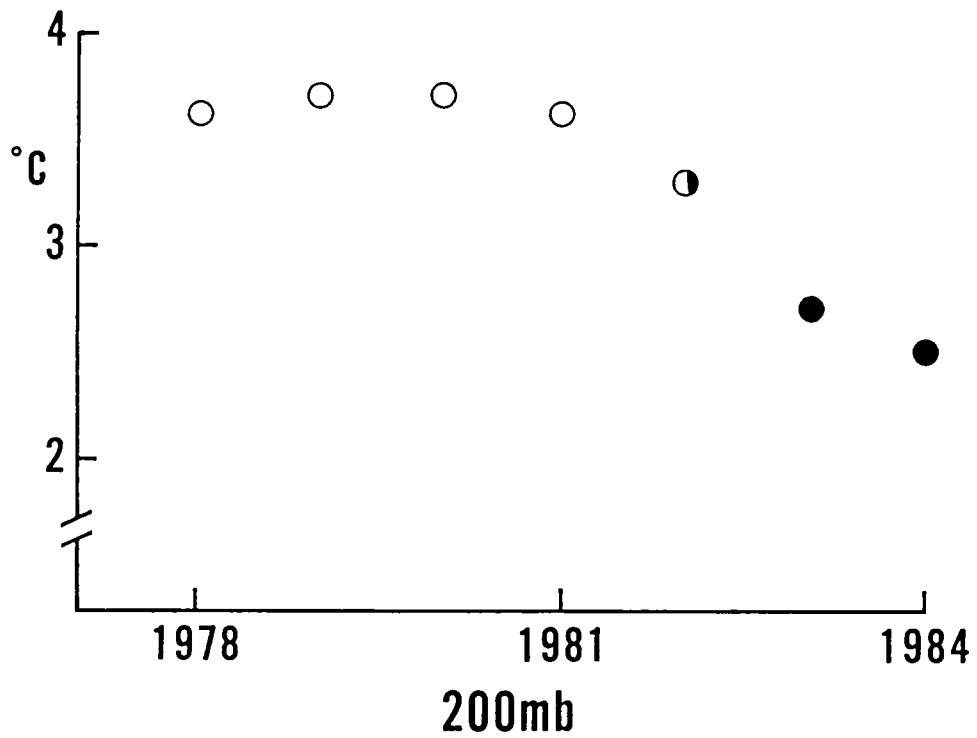

Figure 7. The 1978 to 1984 T + 24 temperature RMS errors for Europe, the Atlantic, and Eastern America.

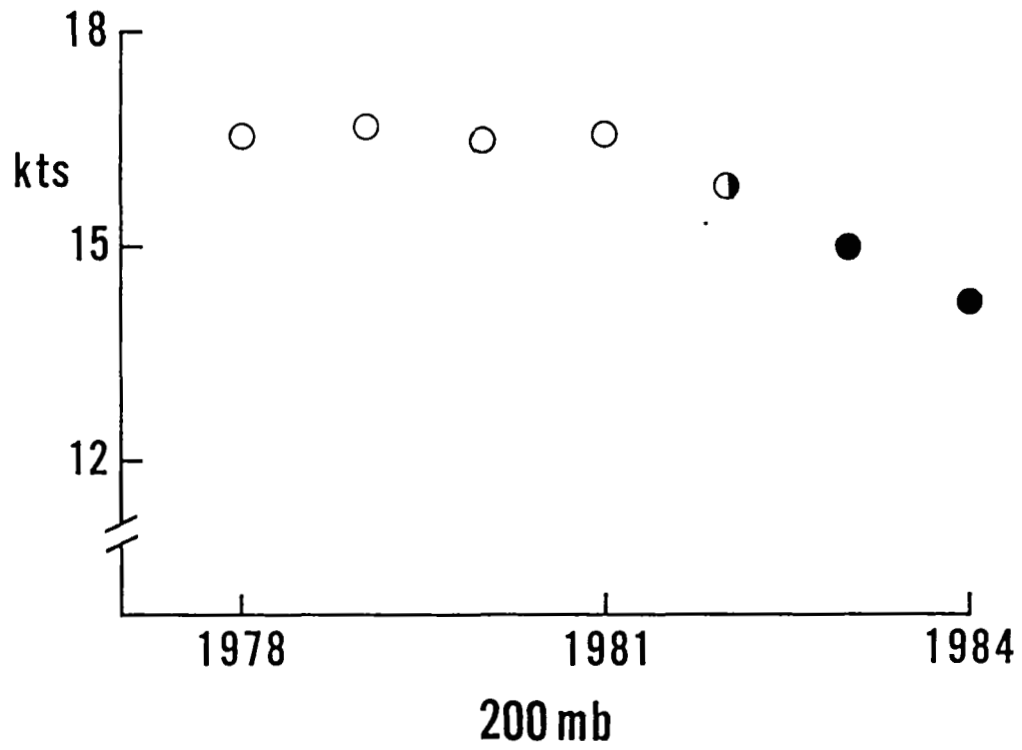

Figure 8. The T + 24 vector wind errors over same area as seen in Figure 7.

SPECIAL OBSERVATIONS

Donald Beran
NOAA Wave Propagation Laboratory

The profiler is one of the new special observation devices. Figure 1 shows the impact of various meteorological data types on "forecast lead time." A scale called "relative importance" is used to avoid advocating a particular sensor. Clearly, radar is most useful in the short, nowcast (out-to-one-hour) time frame. Satellites and surface observations are also most useful for short-range forecasts but have less impact on the longer range. The radiosonde network, on the other hand, only starts to be very important after about 6 hours and has greatest impact at lead times of 12 hours or more. It has even been suggested that forecasts of greater than 12 hours may be better than present short-range forecasts.

Many people speak of a data "gap". A data "valley" is seen in Figure 1, but is not a real gap. So why are we concerned? What do we need to do differently? I submit that we have been viewing this diagram incorrectly, and that, in fact, it is a three-dimensional diagram (Figure 2). Observations are of two fundamental types: 1) those which show atmospheric discontinuities, and 2) those which show basic fields in the atmosphere. It is the atmospheric discontinuities which are most important to one-hour forecasts. For example, radar detects an atmospheric discontinuity (e.g., a thunderstorm), whose position can be extrapolated for a short distance. The second type, the actual measurement of a basic field of wind, temperature, or humidity, is needed to do true forecasting for more than one hour.

We are attempting to correct these weaknesses with VAS and Doppler radar, but I submit that we still have a gap. I further suggest to you in the aviation community that this is a very important area for aviation forecasting. The importance of the two-to-eight-hour forecasts becomes evident when we try to define the critical weather that may be encountered during, for example, a flight from New York to Los Angeles.

Radiosonde vs. Profiler

Of course, radiosondes could be placed at much greater density all over the United States, and the frequency of the soundings could be increased to every couple of hours. This would, however, be extremely difficult to accomplish because of some of the characteristics of a radiosonde (Figure 3). First, it is difficult to obtain good temporal resolution. The temporal resolution of a radiosonde is only as fast as a man can blow up and release a balloon. Even this rate is limited because a second balloon cannot be launched until the first has burst and allowed the transmitter to fall to the ground. Temporal resolution is, therefore, limited regardless of how

IMPACT OF METEOROLOGICAL DATA TYPES

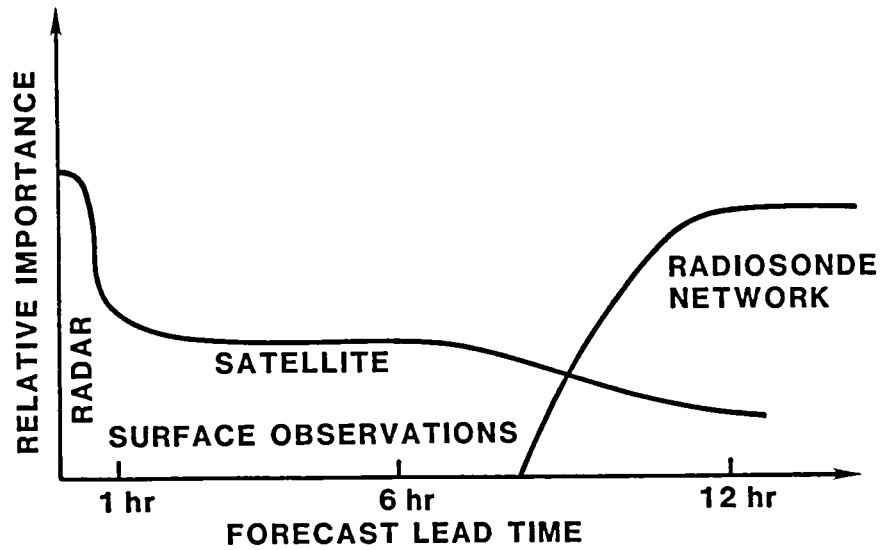

Figure 1. One perception of the impact of various instruments on forecast lead time.

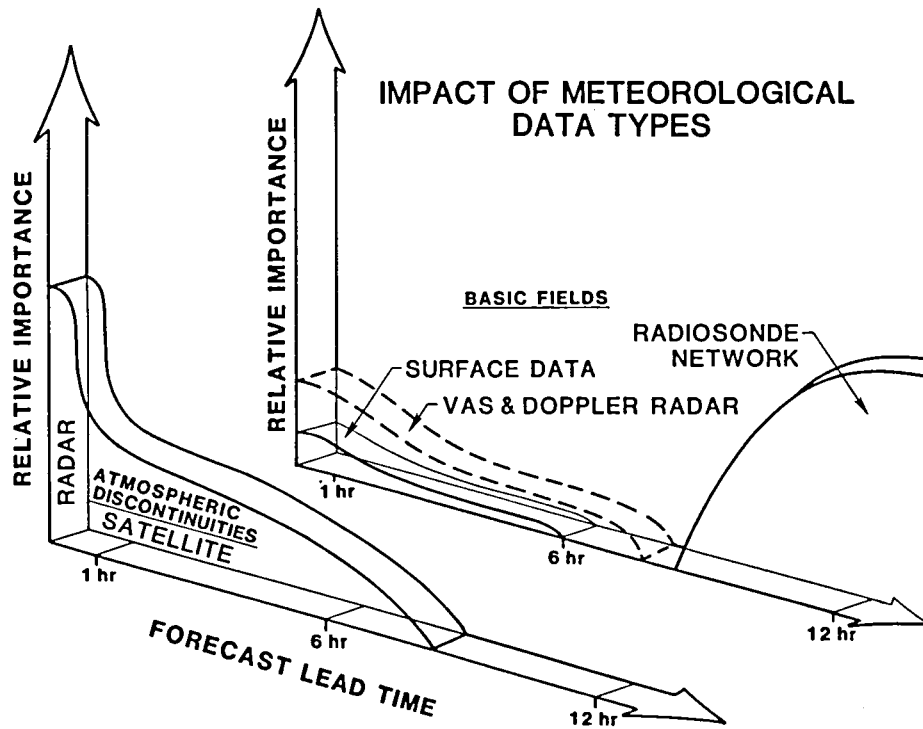

Figure 2. A different view of the impact of various instruments on forecast lead time.

- Accuracy - ?
- Representativeness - ?
- Temporal Resolution - as fast as a man can launch
- Height Limits \approx 100mb
- Labor Intensive
- Reliability = Good
- Automation - Nearly Impossible
- Cost - \$200⁰⁰-\$300⁰⁰/Launch

Figure 3. Some of the characteristics of the radiosonde.

many radiosonde sites are provided. Second, it is nearly impossible to automate a balloon system. Therefore, it would seem preferable to find another solution. We believe it is the profiler.

The wind is measured by using clear-air Doppler radar principles. Two fixed beams, pointing 15 degrees to the north and 15 degrees to the east, sense the Doppler shift. The resulting wind vectors are then rotated to the horizontal and combined to give total wind. Figure 4 is a schematic of a 50 MHz wind profiler showing three beam positions (one vertical). The antenna for this system takes up an area of about 50 m on a side. Figure 5 is a photo of another version of the wind profiler (the 915 MHz system located near Denver, Colorado). Work is currently under way on a 405 MHz system which has a much smaller antenna. This smaller version could well be the forerunner of commercial systems.

Comparisons of the winds measured by a profiler with those from a radiosonde have been made many times over the past few years. We generally find that the profiler is better than the radiosonde. Figures 6 and 7 illustrate the wind measurement capabilities of the profiler. Figure 6 shows winds measured at NOAA's Platteville, Colorado, site early in 1985 when a winter storm was moving through Colorado. A range of 16 km is shown. Figure 6 shows the wind field that would have been measured by 12-hour radiosonde ascents. Figure 7 is the same wind field as measured by the profiler. The profiler is a very high temporal resolution system which operates automatically. You do not need to send up a balloon. During any 12-hour period the profiler can show mesoscale features that simply cannot be seen by using radiosondes. In Figure 7, for example, the profiler winds indicate a mesoscale low-pressure center that would have been missed by 12-hour radiosondes.

The radiosonde measures temperature and humidity as well as wind. Here the story of the profiler is not quite so bright. A profiler measures temperature and humidity by using passive radiometers. Figure 8 is a time/height plot of radiometer-derived and radiosonde-measured temperature profiles near Denver, Colorado. The dashed lines are from radiosonde-measured temperatures 12 hours apart. The smooth curves are the radiometer temperatures. Notice that the radiometer does not see sharp "kinks" in the temperature profile. However, it does show when the ground-based inversion broke up. Some meteorologists suggest that this smooth profile is adequate. Others point out that the ground-based and upper-level inversions are very important in predicting the onset of mesoscale convection. The Wave Propagation Laboratory is doing research on adding the kinks to the radiometric temperature profiles. On the positive side, the radiometric system is capable of very accurately measuring the height of pressure surfaces, one of the primary inputs to numerical weather prediction models.

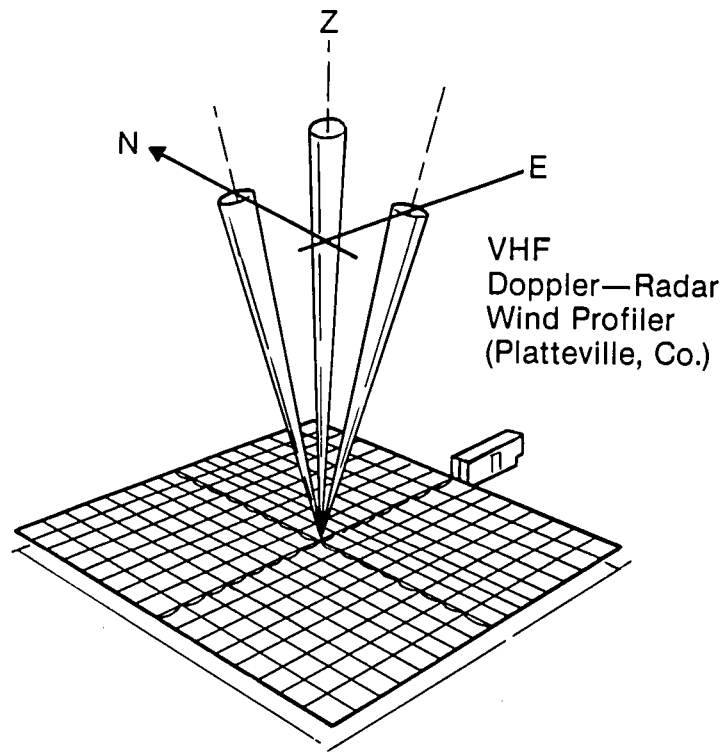

Figure 4. A schematic showing the 50 MHz antenna and fixed beam pattern. The inset shows the building that houses the radar and processing equipment.

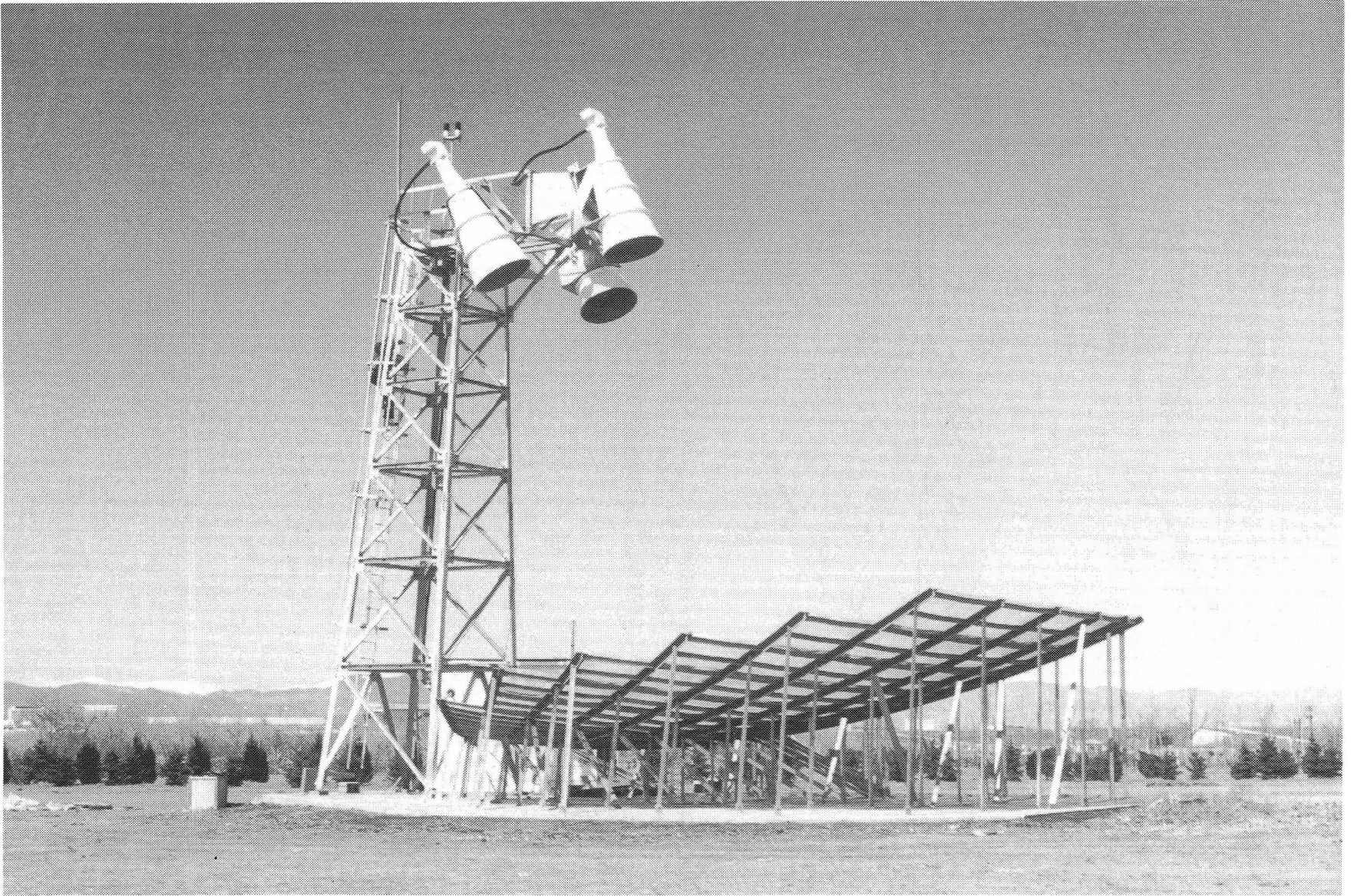

Figure 5. The 915 MHz wind profiler located at Stapleton Airport near Denver, Colorado.

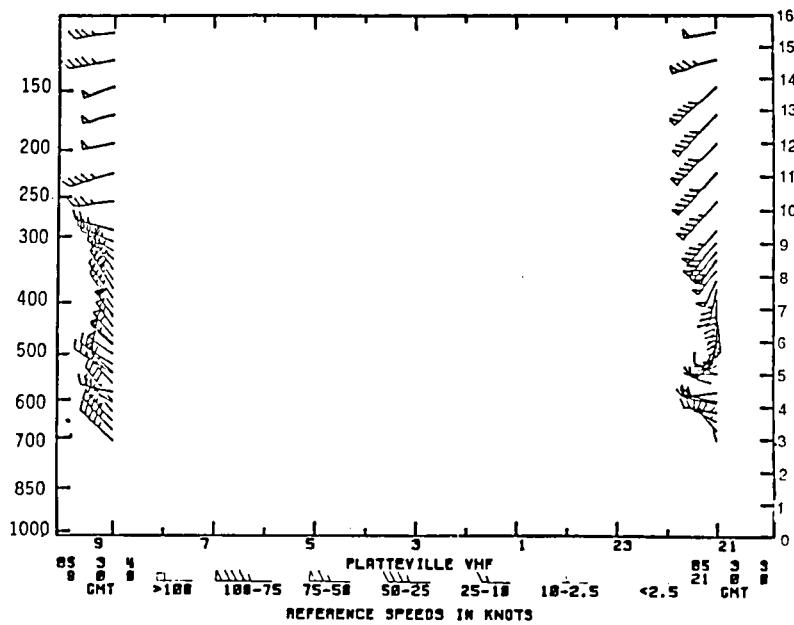

Figure 6. A time/height section of wind profiles. The left vertical scale is pressure height and the right vertical scale is in km above sea level. The wind barb values are given below the figure. Wind direction is represented by the direction of the wind arrow with north at the top of the figure. The two profiles represent the winds that would be measured by 12-hourly radiosonde ascents.

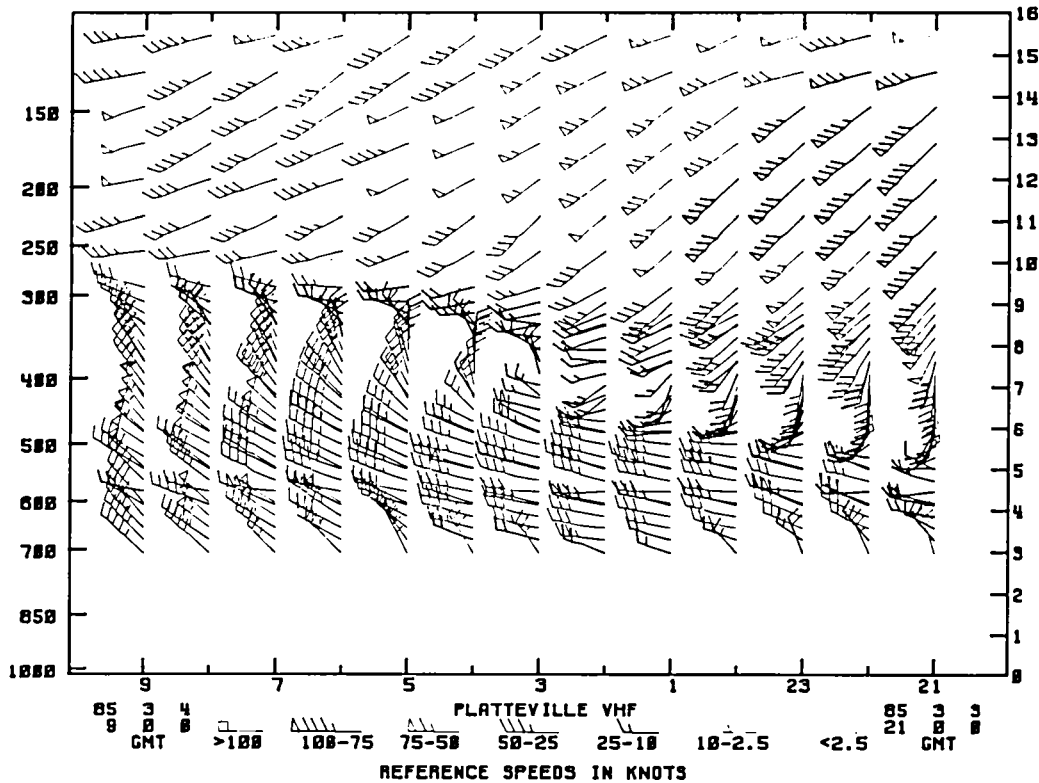

Figure 7. Same as Figure 6, only showing the number of wind profiles that would be provided by a profiler in the same 12-hour period. Note the mesoscale detail that is revealed by the higher temporal resolution.

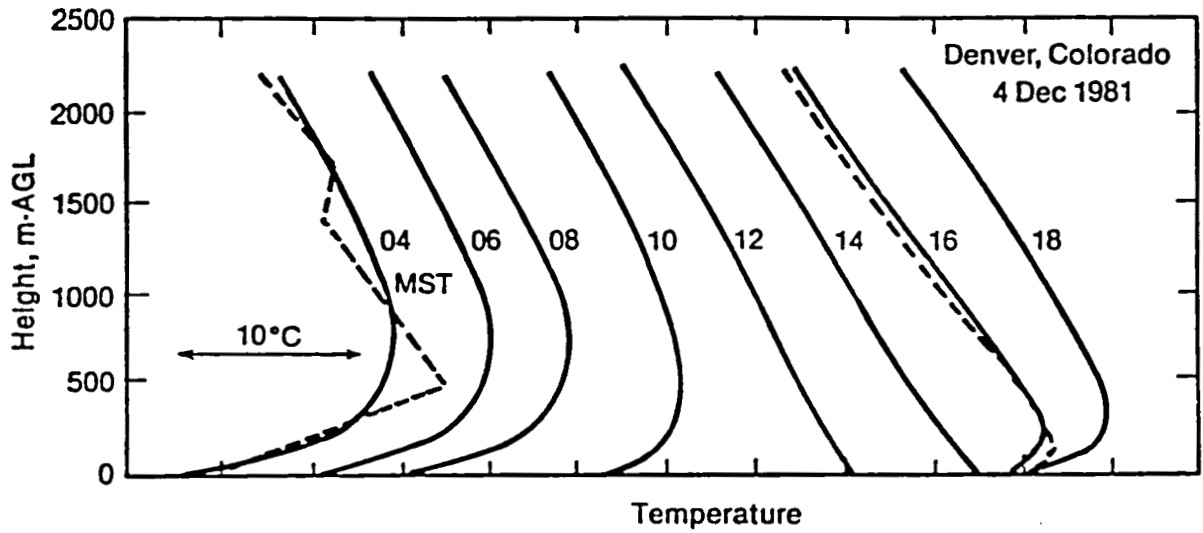

Figure 8. Time/height section of temperature profiles taken by a radiosonde (dashed lines) and a thermodynamic profiler (solid lines). The tic marks on the bottom represent one-hour intervals.

The wind profiler development is 95% complete. It is ready for implementation, and we are starting a program where that will occur. Temperature profiler development is probably only 75% complete. The remaining work is pictorially represented in Figure 9. The dashed lines suggest the sharp inversions that might be seen in a radiosonde trace. The solid lines represent the temperature profiles from a radiometer at various points in our projected research plan. First, we know that by simply combining data from ground-based and satellite radiometers, the height of the profile can be extended. This is an improvement over both the ground-based and the satellite temperature profiles. Second, the wind profiler can detect the height of inversion layers because the radar receives stronger signals from regions where temperature inversions are present. This information can then be added to the profile. Finally, we have shown through computer simulation that the relationship between the temperature and wind field can be used to improve the derived temperature profiles. The high-resolution winds from a network of profilers can be used to reproduce the temperature field and, in turn, to add the kinks in the radiometric temperature profile.

Wind profilers are to be installed in the central U. S. Figure 10 shows one of the proposed configurations for this network. The network will contain 30 to 35 profilers some operating at 405 MHz, others at 50 MHz. This network will be used to test the operational characteristics of the profiler system and to assess the optimum frequency and distribution of profilers in a network.

We are also looking at ways profilers might be used to support such operations as the Space Shuttle launch (Figure 11). This is a rather interesting special problem because, at present, the best wind profile available for launch support is taken three and one-half hours before the launch. With a profiler, winds could be measured right up to the time of launch. The Shuttle recovery problem is equally interesting. It is difficult to provide a four-hour forecast of whether there will be a thunderstorm over the end of the runway. Accurate high-resolution upper-air and surface measurements on and around the Florida peninsula would make the recovery forecast much easier.

Summary

If we are to improve our ability to forecast weather, we must have better high-resolution data sets. We must also recognize that these high-resolution observations are needed for research in order to develop understanding and forecasting techniques. The critical role of high-resolution measurements and their link to automation, training, and improved mesoscale services is depicted in Figure 12. There is one link on this diagram that we seem to overlook. We do wonderful research experiments that employ high-resolution instrumentation. We operate for two months, then remove the instruments and go away to develop new forecast techniques that

THERMODYNAMIC PROFILER

RESEARCH PLAN

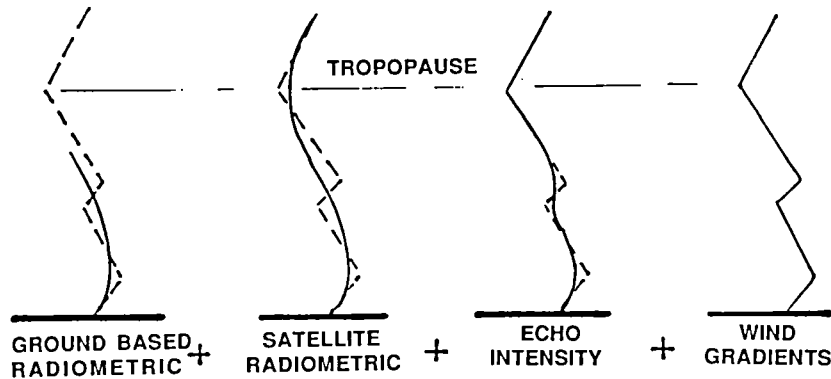

Figure 9. Schematic representation of the research steps required to improve the height resolution of the thermodynamic profiler. See text for fuller explanation.

A Proposed 1989 Wind Profiler Network

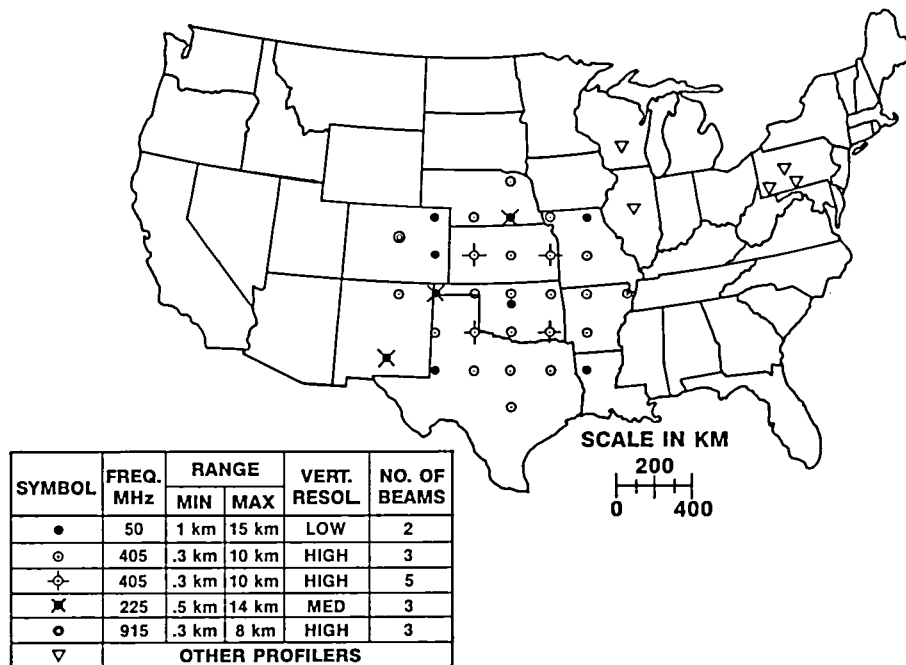

Figure 10. One of the proposed profiler network configurations.

Profiler Support Network for Space Shuttle Recovery

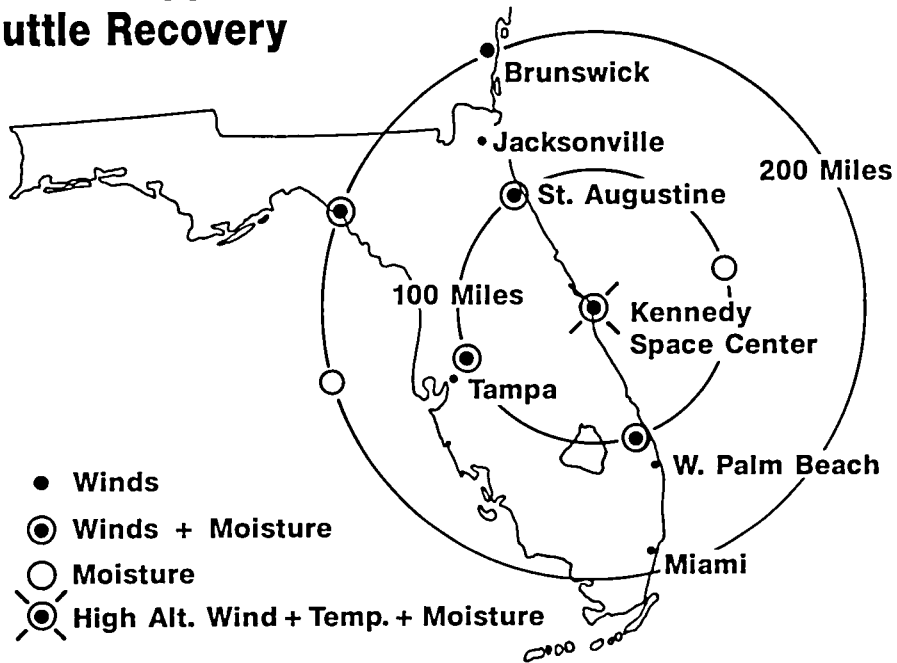

Figure 11. A proposed profiler network for supporting Space Shuttle launch and recovery operations at Kennedy Space Center.

A ROUTE TO IMPROVED MESOSCALE FORECASTS

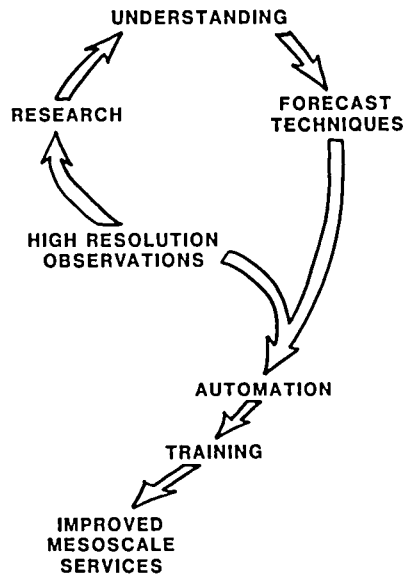

Figure 12. The route to improved forecasts and services.

are given to the operational forecaster to use. But we forget to leave the instruments in the field. How is the forecaster going to make a better mesoscale forecast unless he has available an equivalent set of high-resolution data?

We developed the radiosonde when we had aircraft like those shown on the left side of Figure 13. The right side shows the aircraft that we now have, and we are still using the radiosonde as our basic upper-air instrument. I believe it is time for a change.

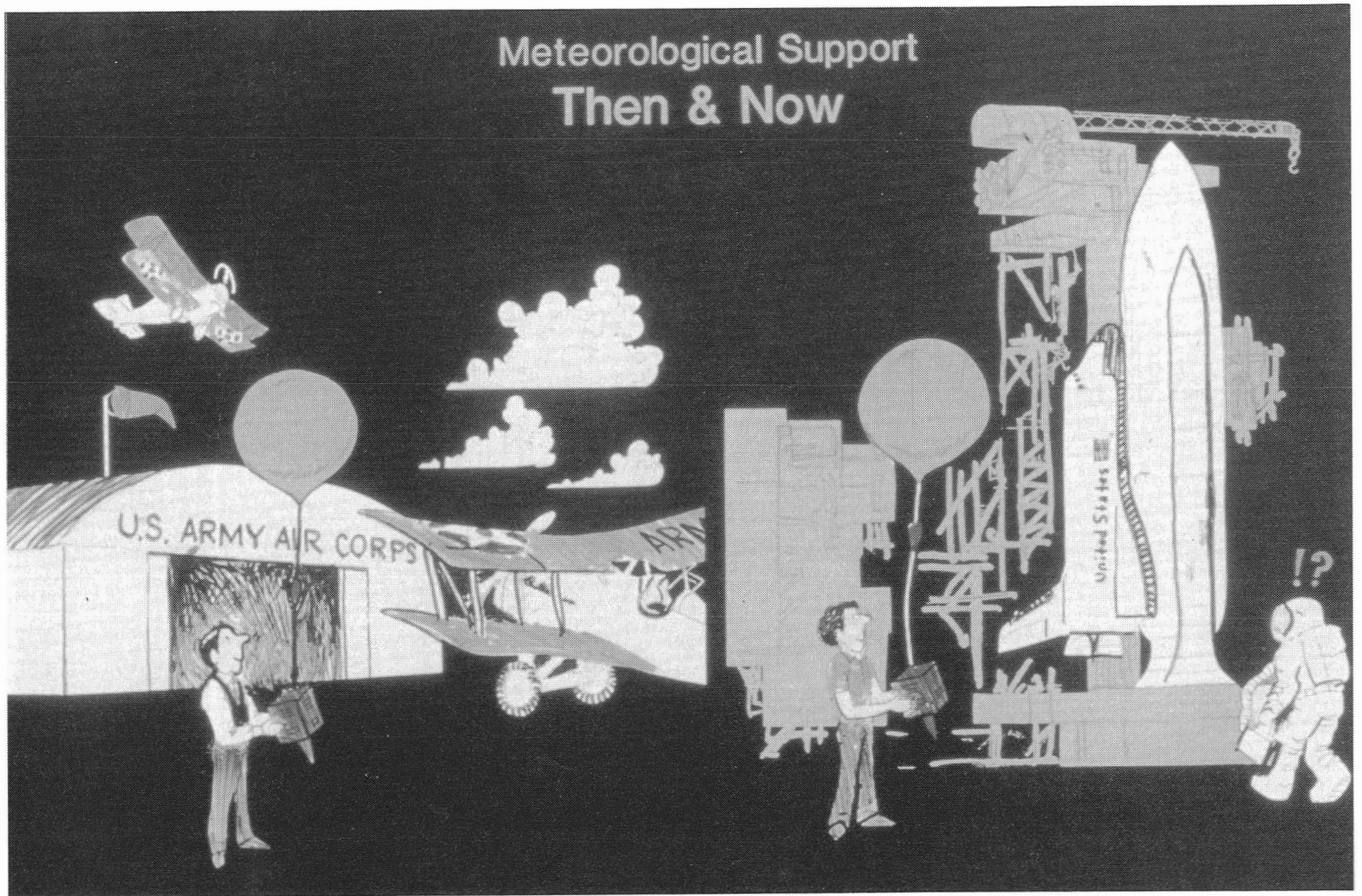

Figure 13. The progress in meteorological sensors compared to the progress in aeronautics.

APPLICATIONS PRODUCTS OF AVIATION FORECAST MODELS

John P. Garthner
Fleet Numerical Oceanography Center

The Fleet Numerical Oceanography Center (FNOC) is a unit of the United States Navy and is located in Monterey, California. This presentation will concentrate mainly on an application of output data from FNOC's Naval Oceanographic Global Atmospheric Prediction System (NOGAPS) model run on a Cyber-205 computer. We operate a service called the Optimum Path Aircraft Routing System (OPARS). It was developed in the late 1970's and early 1980's for Navy, Marine Corps, and Coast Guard aircraft primarily to save fuel. The aircraft shown in Figure 1 is the NC-4, and it was the first aircraft to cross the Atlantic, in May 1919, several years before Lindbergh flew nonstop. Three Navy aircraft started from Rockville, New York; went to Halifax, Nova Scotia; Nova Scotia to the Azores; from the Azores to Lisbon; then from Lisbon to Portsmouth, England. Of the three that started, only one completed the trip. It took them 20 days, and navigation en route had to be assisted by several ships stationed along the flight route. They had to fly low to see the ships as there were no NAVAIDS and forecast meteorological information was nonexistent. I use this aircraft as a logo as it is acceptable by all the aviation communities of the Navy and Marine Corps. Also, this is probably the first time that the requirement for a computer-assisted flight planning program was defined. This aircraft was restored by the Smithsonian Institute and is presently on display at the Naval Aviation Museum in Pensacola, Florida.

The Cyber-205 NOGAPS model is run once each 12 hours and once the run is completed, oceanographic and meteorological forecast data are transferred to other computers for use in applications programs. OPARS is one such program. Figure 2 illustrates the Primary Environmental Processing System (PEPS) which is a bank of two computers. OPARS operates on a separate computer affectionately known as HAL. At the present time, it is a CDC-6500, but will soon be replaced by a CDC-860. People around the world will be able to dial in on value added network directly into HAL, supply input, and gain an output. If they have any difficulties, there are people on watch 24 hours a day for assistance. Another method of getting a flight plan is by use of the DOD message system. In this case, the PEPS computers process OPARS and generate a return message. A message is returned within 2-4 hours after receipt of the request. Figure 3 is a graphic which depicts the sites we service on-line (value added network). They range from the Philippines and Japan through Alaska and the Hawaiian Islands, throughout the United States, Bermuda, Puerto Rico into Spain and Europe. All these sites have direct access into our computer at Monterey.

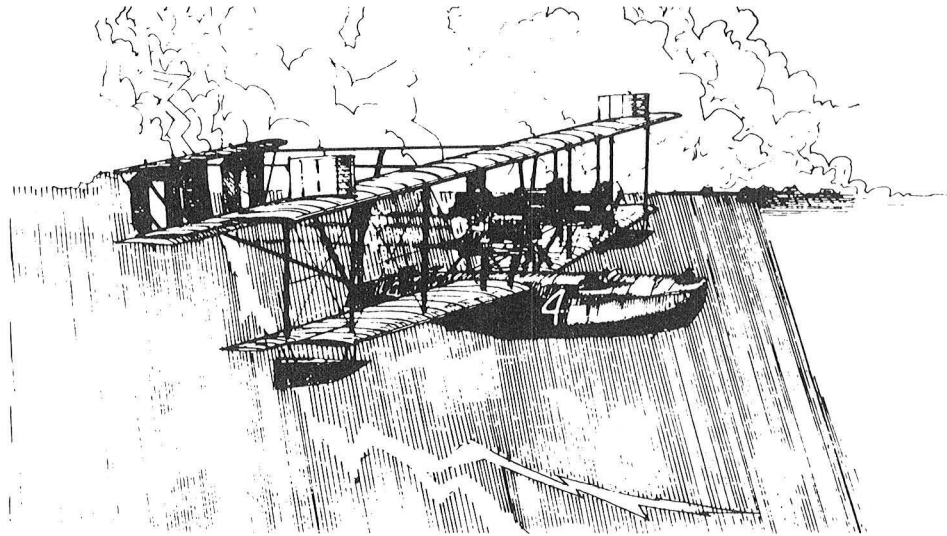

Provide recommended optimum flight plan:

- Fuel management
- Time en route

Figure 1. Optimum Path Aircraft Routing System (OPARS).

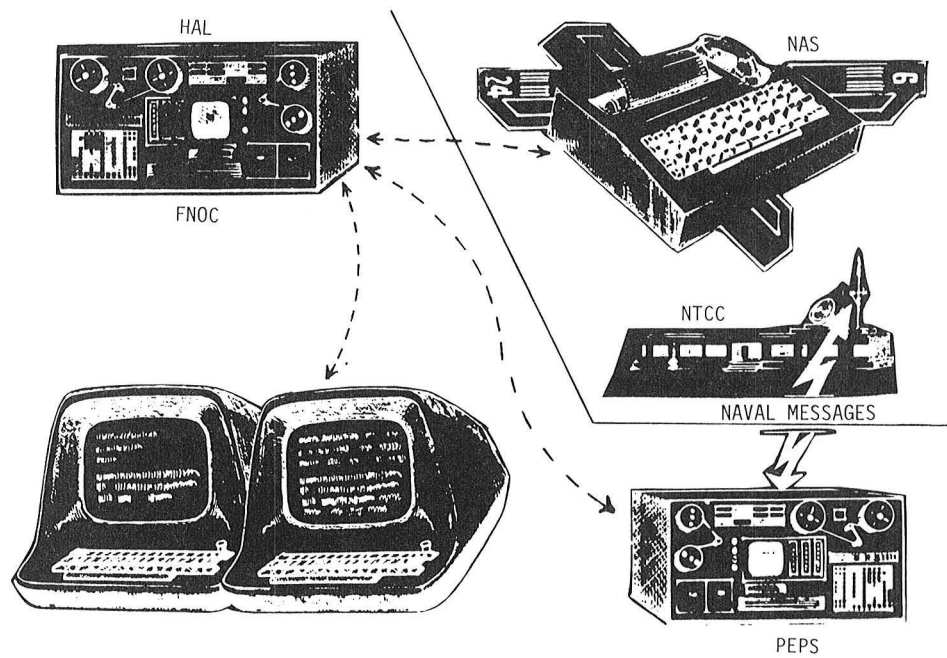

Figure 2. Optimum Path Aircraft Routing System (OPARS).

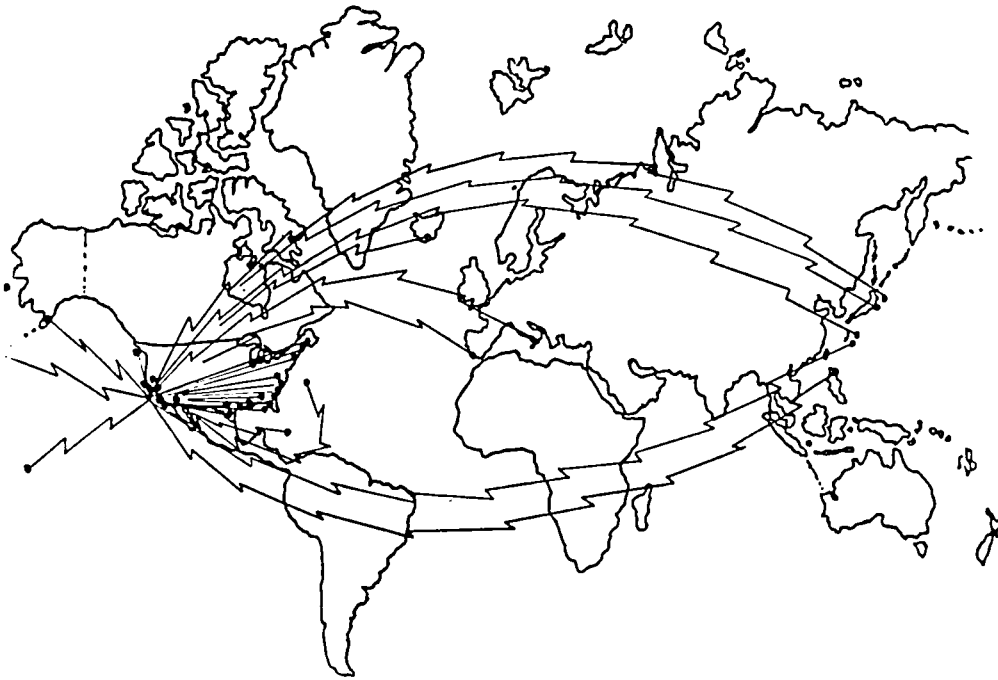

Figure 3. Sites regularly served by OPARS from FNOC.

FLIGHT PLAN FORMULATOR

- RSU - Request Set Up
- FPF - Flight Plan Formulator
- PRA - Post Route Analyzer
- OPA - Output Preparation = Archival

COMMUNICATIONS

Interactive
Request

ENVIRONMENTAL DATA

Global Update Every 12 Hours
Time/Space Interpolation Every Flight

DATA BASE MANAGER

- Aircraft Performance Curves
- Routes - Airports - Nav aids
- Restricted Areas

Figure 4. Major subsystems of OPARS.

The computer program is divided into four major subsystems (Figure 4): 1) the Flight Plan Formulator does the actual processing, by calling upon several data bases to enable the system to run properly. 2) The Communications subsystem allows the user to interface with the computer to enter the request and receive the flight plan. 3) The Data Base Manager stores the data bases that remain relatively static such as aircraft. For Navy aircraft we use performance data depicted in the Naval Air Training and Operating Procedures Standardization Program (NATOPS) manuals provided for each aircraft. The air routes, airports, and NAVAIDS are provided in computer-readable format by the Jeppesen Sanderson Corporation of Denver, Colorado. This data base is updated every 28 days and consists of all the air routes, NAVAIDS, waypoints, and all airports (with hard surface runways 5,000 ft. or longer) in the Northern Hemisphere and selected areas in the Southern Hemisphere. The prohibited area data base is static as most prohibited areas remain constant. Input options will either allow or not allow aircraft to fly through these areas. 4) The Environmental Data subsystem consists of winds and temperatures extracted from the NOGAPS model which is run once each 12 hours. OPARS primarily uses the 12- to 48-hour forecast winds. Temperatures and winds are extracted from the surface to 100 mb, approximately 55,000 ft. We also have a level of maximum winds which approximates the tropopause level. NOGAPS is usually complete within four and one-half hours after observation time, and processing the wind/temperature data takes another hour, so the first available winds for OPARS come from the 12-hour forecast. Most flight plans are processed using the 12- to 36-hour forecast winds. For the flight simulation we use a time and space interpolation (space being the proper altitudes for the most efficient (optimum) flight profile). Time is the forecast winds nearest the actual time of flight. Forecast winds are available in six-hour time steps; i.e., 12-hour, 24-hour, 30-hour forecasts, etc. For a while we toyed with the idea of interpolating right down to the actual forecast minute that an aircraft would transmit a position, but found that it was difficult to obtain a viable method of averaging the wind vectors to depict accurate winds (average velocity is normally too low). We decided to go with the 6-hour time step since it is a direct extract from the NOGAPS model.

For the past 14 months we have been verifying winds over regions where we feel the NOGAPS model is most likely to be weak, and where radiosonde station sites are located so we can verify forecasts with observations. The regions are the east coast of Asia; off the west coast of the U. S., where a trough can migrate west or east of actual position (winds potentially 180° in forecast error); a track across the northern U. S.; another across the mid-United States, to pick up any errors in jet stream migration; along the east coast of the U. S.; across the North Atlantic; and through the Mediterranean area. During these 14 months, we concentrated our effort on the 24-hour forecast at the 300 mb level. We simulate flight in both directions through each area. Flights are about 2,000 miles long, and we use a

Navy C-9 Aircraft. The results to date have been very good as we have about 99% probability of being within 15 minutes of estimated fuel (1000 - 1200 lbs.) using the 24-hour forecast winds and temperatures. As the NOGAPS model improves, I feel we also will improve.

Figure 5 is an example of a typical input into the OPARS system. There are multitudes of possible input combinations, of course, but the one shown in Figure 5 was chosen because it is a short flight and easy to read. The input consists of a C-9B aircraft using a normal rate of climb, maximum range cruise, idle descent, and a specified output mode for a one-leg flight plan. We can run up to three legs at one time with any combination of refuel options. A leg is defined as from one point of departure to one point of arrival. In this case a \$R\$ was selected which is defined as flying on jet routes, if possible, but it is permissible to fly NAVAID direct between jet routes. We have an option forcing OPARS to remain on jet routes, and it is primarily used in the European areas. We can also fly inertial direct, inertial optimize, and any other combination that may be appropriate, but \$R\$ seems to be the most popular. Since we climb out and descend on course, we provide for additional fuel/time estimates in the departure and arrival bias inputs. In Figure 5, the point of departure was San Francisco arriving at KNZY, which is Navy North Island in San Diego.

Figure 6 shows the output calculated from the input shown in Figure 5. The cargo/fuel mix for the aircraft in this flight was determined for maximum load capability, and the time of flight was calculated to be one hour and fourteen minutes requiring 7,349 lbs. of fuel, a 45-minute reserve (at FL 100) calculated at 4,800 lbs. which totaled a 12,149-lbs. required fuel onboard. The computer calculated a maximum cargo of 29,197 lbs. The routing was from San Francisco direct to Salinas then direct to North Island, and did not select any jet routes in this example. The captions across the bottom of Figure 6 represent the checkpoint, flight level, temperature deviation, winds, true course, true heading, mag heading, true airspeed, ground speed, zone distance, cumulative distance, estimated time en route, estimated time remaining, estimated fuel usage, and estimated fuel remaining. This is one of eight possible output formats.

The wind printed on this plan is not the same wind used to calculate the fuel usage and time between checkpoints. After trying several averaging methods, we settled on a simplified trapezoidal interpolation between checkpoints which is more accurate than simply averaging end point winds. The winds printed in the example in Figure 6 are derived by going back into the environmental data base and interpolating the wind at the checkpoint location and altitude. This can be verified by the pilot by reading actual winds on his inertial navigation/Doppler system. If the winds are right on, then he knows that the forecast is good and the fuel/time data from OPARS is accurate. If the winds are a little off, then he has to take

USER	=U,OPFO
PILOT	=LT JONES
ACTYPE	=C9BFNF
OMODE	=2KB
LEG	=1
POD	=KSFO
TOD	=04OCT1983 ,2100Z
OPWT	=65000
CARGOCH	=C
ROUTING	=\$R
DBIAS	=500,5
ABIAS	=500,5
POA	=KNZY
RESERVE	=C
COMMAND-	

Figure 5. Example of typical OPARS input.

J,65

FLIGHT PLAN FOR LT JONES COMPUTED 1332Z
BASED UPON 8310040000 WEATHER DATA
LEGG1 STANDARD KSF0 TD KNZY
ACFT TYPE C9BFF 10/04/82
PLANNED FOR ETD 2100Z INITIAL CRUISE FLIGHT LEVEL 290
FOA FUEL TIME DIST ARRIVE TAKEOFF LAND CARGO OPNLWT
ALT 007349 1/14 0391 2214Z 108345 098997 029197 065000
RES ...
TOT 004800 0/45
 012149 1/59
FUEL BIAS: 0 DBIAS: 500 ABIAS: 500 IBIAS: 0
ROUTING USED FOR THIS LEG
KSF0 .. SNS .. NTD .. KNZY

OPT	F/L	TMP	WIND	T/C	T/H	M/H	TAS	G/S	ZD	CD	ETE	ETR	EFU	EFF
KSF0	1	00	00000	000	000	*****	***	***	000	0000	0/01	1/14	000	0121
KSF0	N37372W122225													
SNS	199	P11	09023	147	144	127.0	***	***	068	0068	0/13	1/00	023	0098
SNS	N36398W121361													
TCC	290	F10	07529	142	138	122.0	***	***	079	0147	0/16	0/44	020	0078
TOC	N35378W120354													
NTD	290	P09	14509	141	140	124.7	436	426	116	0263	0/16	0/28	016	0062
NTD	N34074W119073													
SLP	290	P09	20515	132	133	117.9	434	428	035	0298	0/05	0/23	005	0057
SDP	N35442W118361													
KNZY	0	P01	12510	132	132	118.6	***	***	093	0391	0/23	0/00	010	0047
KNZY	N32420W117129													

TOTAL WIND FACTOR -4KTS

=====

Figure 6. Example of OPARS output from input format shown in Figure 5.

alternate action. Since the beginning of our operation in 1980, I do not know of anyone's having to divert due to inaccurate environmental data. In this example, the total wind factor is shown to be -4 kn.

Figure 7 is an example of an abbreviated output format used for planning purposes, and has basically the same summary information as that in Figure 6. Figure 7, however, was from Travis to Hickam AFB. It does not show all the checkpoint navigation, but does indicate the planned route, penetrated airspaces, and total wind factor. Its primary use is for planning purposes (i.e., run several with different cargo loads, etc.). Figure 8 is a popular output for pilots, a "how goes it" type of output. The flight crew must connect the dots to complete the graph. Then during the flight, the pilot plots actual fuel at each checkpoint. If it plots on the line or to the right side of the line, then fuel usage is as (or better than) predicted. If the plot is to the left, then more fuel is being expended than planned for and some corrective action or a divert is in order.

Figure 9 lists some of the other benefits of the OPARS system. Within the military, entire squadrons of aircraft are deployed from time to time, and this system is used to plan time and fuel requirements for the deployment. The system is also used to plan aircraft carrier wing fly on/off scenarios which can be extremely complicated (up to 70 aircraft at a time). One main benefit for the C-9 transport community is for planning maximum flight time versus crew rest requirements. This enables a schedule to be followed to make sure an aircraft is back at home base and ready for the next day's mission rather than somewhere else, because a lot of time was saved by letting the computer help plan the flight. The crew spent most of their workday in the air and not in Base Operations planning the flight.

Figure 10 shows the areas covered by the OPARS system in a representation flight from Jacksonville, Florida, to Spain. All the winds are loaded into this entire area at/around the optimum altitude that the aircraft should fly. Flight is simulated through all altitudes to deduce the best fuel usage.

FLIGHT PLAN FOR AIR FORCE

COMPUTED 1804Z

BASED UPON 8401040000 WEATHER DATA

LEGO1 STANDARD KSUU TO PHHI

ACFT TYPE C9BFNF 1/04/84

PLANNED FOR ETD 2200Z INITIAL CRUISE FLIGHT LEVEL 310

	FUEL	TIME	DIST	ARRIVE	TAKEOFF	LAND	CARGO	OPNLWT
POA	029368	5/34	2125	0334Z	109998	080630	009630	065000
ALT	...							
RES	006000	1/06						
TOT	035368	6/40						

FUEL BIAS: 0 DBIAS: 500 ABIAS: 500 IBIAS: 0

ROUTING USED FOR THIS LEG

KSUU .. SAU D230 BEBOP R64 PHMAGGI V12 PHJOELE .. PHHI

TOTAL WIND FACTOR -36KTS

FOLLOWING AIRSPACES PENETRATED

FIR BOUNDARY	KZ /KZOA	AT 2231Z
FIR BOUNDARY	KZOA/PHZH	AT 0239Z

Figure 7. Example of abbreviated format from data shown in Figure 6.

FLIGHT PLAN FOR AIR FORCE COMPUTED 1804Z
 BASED UPON B401040000 WEATHER DATA
 LEG01 STANDARD KSUU TO PHHI
 ACFT TYPE C9BPNF 1/04/84
 PLANNED FOR ETD 2200Z INITIAL CRUISE FLIGHT LEVEL 310

	FUEL	TIME	DIST	ARRIVE	TAKEOFF	LAND	CARGO	OPNLWT
POA	029368	5/34	2125	0334Z	109998	080630	009630	065000
ALT	...							
RES	006000	1/06						
TOT	035368	6/40						

FUEL BIAS: 0 DBIAS: 500 ABIAS: 500 IBIAS: 0

ROUTING USED FOR THIS LEG
 KSUU .. SAU D230 BEBOP R64 PHMAGGI V12 PHJOELE .. PHHI

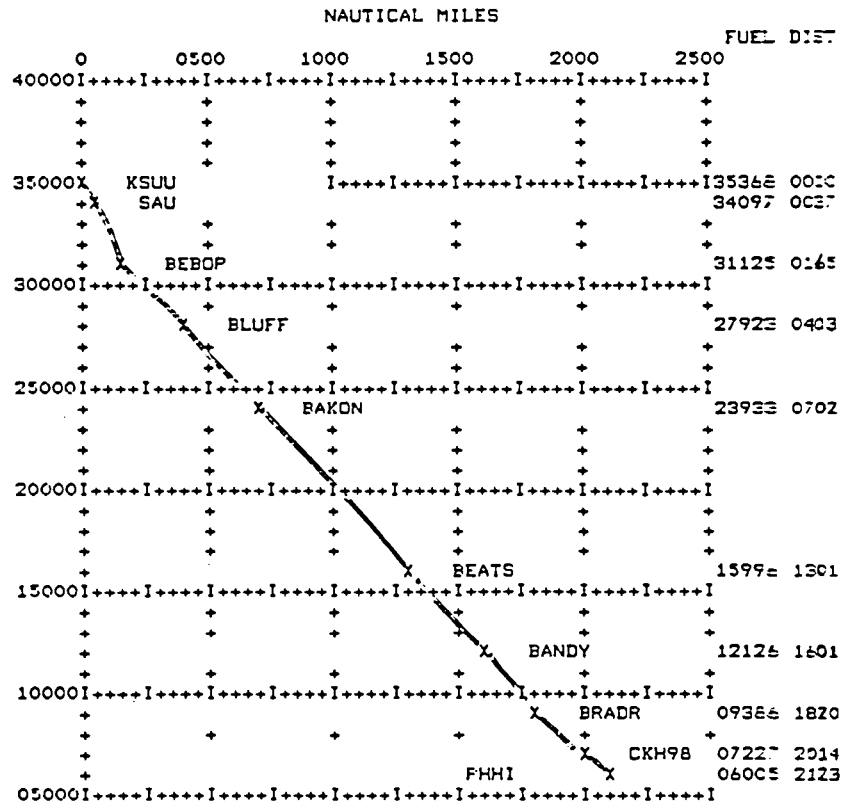

Figure 8. Graphic data display for pilots using same data as Figure 6.

TACTICAL MISSION PLANNING
AIR-TO-AIR REFUEL PLANNING
DEPLOYMENT PLANNING
AIRCRAFT CARRIER FLY ON/OFF PLANNING
OPTIMIZE FUEL LOAD/CARGO MIX
MAXIMUM FLIGHT TIME VS. CREW REST

Figure 9. Additional benefits of the OPARS system.

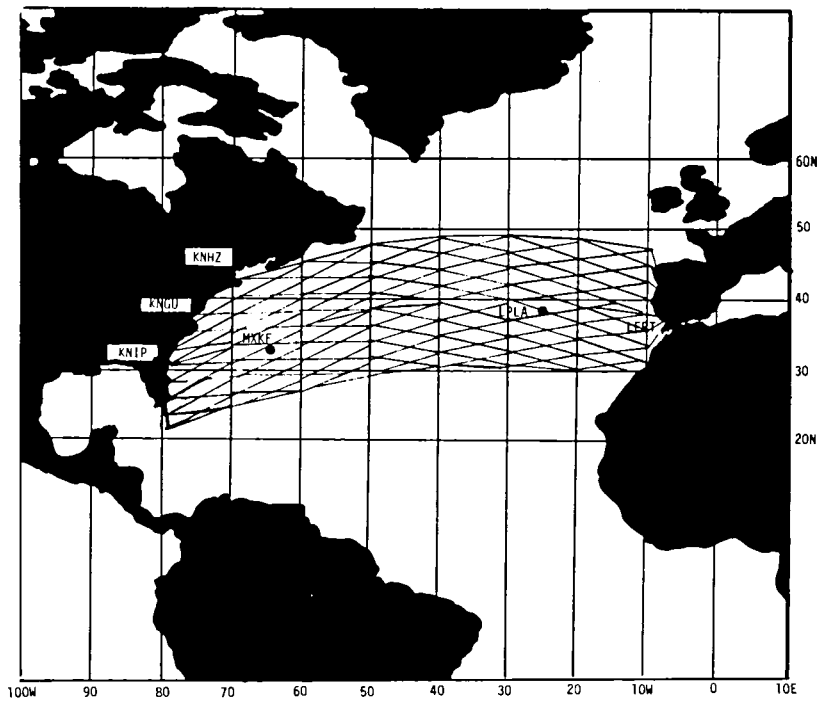

Figure 10. Areas covered by the OPARS system in representation flight.

GENERAL-AVIATION'S VIEW OF PROGRESS IN THE AVIATION WEATHER SYSTEM

Douglas J. Lundgren
AOPA

AOPA represents a wide variety of aviation interests among its 265,000 members who are a cross section of the 730,000 active pilots today. Our members own and fly the majority of the 210,000 civil aircraft registered for personal, business, and commercial purposes. We fly more than five times as many hours annually as do the air carriers (into nearly 13,000 airports). General-aviation fuel taxes are funding both the operation and capital improvements of the FAA's National Airspace System and help to reimburse the aviation programs of the National Weather Service.

The Continuing Impact of Weather on Aviation Safety

For all of its sheer mass of activity statistics, general-aviation inevitably is the most vulnerable to hazardous weather. Our members generally fly in the weather the whole route, unlike air carriers which can fly above most en route weather. To quote from the November 1984 Report of the House Subcommittee on Investigations and Oversight entitled, "The Impact of Weather on Aviation Safety:"

"Weather has long been known to be a contributing factor in about 40 percent of air accidents. Air carrier accidents get the most public attention, but general-aviation accidents result in the most casualties. Adequate and timely weather information is not reaching the pilot in the cockpit; often pilots do not get the hazardous weather information available from the National Weather Service." The report continues, "These comments made in 1975 illustrate the life-costing criticality of unavailable or misleading weather information, the weak links in communications and observation that prevent the transmission of timely and accurate weather information, and the inability of federal agencies to improve this situation."

That was a decade ago. What progress has been made in the aviation weather system since then? The good intentions of the FAA and NWS are borne out by good studies and good plans. For example, the FAA's Aviation Weather System Plan is evolving into an excellent guide to planned improvements and user requirements. Unfortunately, fairly straightforward improvements seem to drag into long-term programs. FSS Automation, AWOS, NEXRAD, High-Altitude EFAS, DUAT, and Voice Response System are all examples of the "moving target" syndrome.

Meanwhile, technology charges ahead both in the private sector and in the government's own think tanks. The irony is that just when there appears to be light at the end of the tunnel for a long-term government project, the private sector often produces cheaper, better alternative products which must fight uphill against the "not-invented-here" (NIH) syndrome.

Since this workshop seeks to educate its participants to real-world problems faced by aviation users, we have hope that your approaches to aviation weather services will indeed be "service" oriented rather than merely "program" oriented.

SPECIFIC CONCERNS: Weather Collection, Processing, Products and Dissemination

While AOPA generally approves of the direction that the Automated Weather Observation System (AWOS) program is headed, the glacial pace of actually getting the units out to the field is unacceptable. While we appreciate the amount of research and development required to provide a machine capable of meeting NWS Part 121 (airline) observation and forecasting requirements, we need at least a basic modular AWOS now to satisfy Flight Standards requirements at unmanned locations with instrument approach procedures. We do not see any air traffic locations to be a priority for AWOS at this point until the flight standards locations receive at least the equivalent of an AWOS-1 (no ceiling or visibility) unit. The planned 400 flight standards units and estimated 400 Airport Improvement Program units will still yield a shortfall of more than 100 airports with instrument approach procedures without weather observation service. In addition, the impending loss of remote altimeter authorization for airports with instrument approaches in mountainous areas is a further, recent impetus to getting simple sensors out there where they are needed most.

The reason that AOPA is not as concerned about getting AWOS to FAA tower and FSS locations is that there is a provision for adequate replacement service throughout the contract weather observation program. Although the goal is to eventually have AWOS replace these observers, we feel the intervening period can be spent profitably in getting basic AWOS-1 deployed to unmanned locations as mentioned above.

Meanwhile, the AWOS-3 (full observation capability) can be perfected to bring it up to the "equal or better service" standard required for replacement of human observers. Although we feel certain of FAA's commitment to support a contract observer program, there are many unanswered questions for which we hope there will soon be answers:

- Who in FAA will arrange and supervise these contracts?

- What will govern their hours of observation coverage?
- Will they be around to take “specials” as needed?
- How long will these contracts last?
- Will their observations be available through the airport’s UNICOM frequency, if a non-tower location?
- Will FAA retain certain Flight Service Stations in mountainous areas and Alaska where neither AWOS nor contract observers are feasible, as Administrator Engen of FAA has recently testified?

Of great concern to us are the continuing efforts of NWS to withdraw from both the observation and dissemination roles of the aviation weather system. For example, the Nebraska Plan of cooperative NWS/FAA/state-supported supplemental observations has been damaged in many places because of NWS withdrawal from the program. Alaska just lost seven formerly joint NWS/DOD observation points, while the State of Minnesota and FAA have been unable to expand the Minnesota Shared Weather Observation Plan beyond six of 14 planned sites since NWS has pulled out.

There is a growing awareness that many more observation points are needed nationwide to improve the accuracy of terminal and area forecasts, but lack of capacity in the Service A, AFOS, and 604 circuits have helped constrain the addition of more reporting locations to the system. Again, the State of Minnesota will be taking matters into its own hands shortly with a grid network of “mini-AWOS” sensors across the state tied to its own communications network. The rest of us have to hope that weather circuit capacity improvements through NADIN and the WMSC-Replacement are finally in sight.

Let us now turn to forecast products themselves—area forecasts, terminal forecasts, and winds aloft forecasts. In short, they all need some more work. Although weather forecasting will always remain somewhat of an imprecise science, we simply need more accurate information on icing conditions, convective activity, precipitation, low clouds, fog probability, and frontal passages. We know that much money and effort has been expended on exotic products such as the Automated Route Forecast (ARF), but we have the nagging feeling that it may be victim of “garbage in—garbage out” if basic forecast processes are not improved.

Area and terminal forecasts would benefit directly from more observation points, earlier hours at part-time locations, and more frequent observations. AWOS and Aviation Surface Observation System (ASOS) will obviously be the ultimate solutions to these needs, but again, holding the line on human observations until then is needed.

Area forecasts presently suffer from a disorganized format on Leased Service A, making it difficult for the briefer to grasp the entire picture. Private sector aviation computer services (avcomps) vendors report that it is a major task to clean up the area forecast mess before releasing this data to their customers. We would expect that any FAA-sponsored Direct User Access Terminal (DUAT) service would have a presentation as well organized as that of the private sector avcomps vendors.

Due to the twice-daily frequency of upper-air soundings, it is not uncommon for winds aloft forecasts to rely on raw data more than ten hours old. The promise of improvements through profilers, and AMDAR and ASDAR automatic airborne winds aloft relay are encouraging. Since benefits to general aviation are dependent on the participation of air carriers and, to a lesser extent, corporate jets in the latter two programs, we can only lend our support.

Pilot Reports (PIREPs) are still falling through the cracks in the collection, processing, and dissemination phases. PIREPs will always be of vital importance to general aviation to complete the often incomplete picture painted by a preflight briefing. A single PIREP confirming icing conditions aloft received in time can be enough to keep a number of non-equipped aircraft on the ground or to seek a safer altitude or route. Although we understand that the FAA mounted a substantial controller PIREP awareness and solicitation program within recent years, the momentum must be maintained. Pilots for their part are happy to give PIREPs if they have the opportunity and if they think their reports will indeed be distributed. Although improvements in communications and switching systems will be delayed until a low-cost cockpit weather display system is authorized for use in the National Airspace System. Although both controllers and EFAS specialists should have the latest weather information including PIREPs at their fingertips, hard IFR conditions will almost certainly always jam voice ATC and EFAS frequencies.

This leads us to their entire spectrum of in-flight weather dissemination. A full eight years after the Southern Airways Flight 242 accident near New Hope, Georgia, there is virtually no progress in cockpit weather displays on the part of the Federal Government. We have seen the FAA/Mitre VOR ground-based radar uplink come and go, satellite radar display experiments in the private sector, the NASA/Kavouras F-106 cockpit radar display, and very shortly, a ground-based six-level color ground-based weather radar display in a State of Minnesota King Air.

Besides graphic products, we sorely need basic alphanumeric displays as well. It is bad enough that EFAS still has only one nationwide voice frequency, but serious thought should be given to making EFAS facilities providers of digital cockpit weather data as well as voice.

Speaking of EFAS, we have no objections to EFAS consolidation to conform

to Air Route Traffic Control Center (ARTCC) boundaries if it leads to closer coordination with associated Center Weather Service Units (CWSU). However, EFAS consolidation, like Flight Service Station (FSS) consolidation, requires adequate staffing, training, and communications outlets.

We welcome the expansion of the Hazardous In-flight Weather Advisory Service (HIWAS) as a needed supplement to controller and EFAS-delivered advisories. However, we are troubled by the simultaneous erosion of both NDB and VOR Transcribed Weather Broadcasts (TWEB). To again cite the 1984 House Report "The Impact of Weather on Aviation Safety": "The subcommittee recommends that FAA assume responsibility for actively disseminating weather information to general aviation pilots through the Flight Service Stations." HIWAS is a step in the right direction, but it cannot replace the comprehensive picture that TWEB provides.

The continuing deficiencies in the FAA's preflight weather dissemination system need no introduction. Briefly, the Flight Service Automation System (FSAS) is a classic example of a "moving target" completely missing the mark of satisfying user needs.

Readily available improvements to the existing system have been held hostage to FSS consolidation, which in turn is held hostage by the snail's pace of FSS automation.

Meanwhile, we have continuing problems with telephone briefing access due to staffing, equipment, and toll rates; trouble-prone Leased Service A Systems; inadequate recorded telephone products; and lack of timely, quality graphics products. It may be to our advantage to have new FSS hubs open as soon as possible to take advantage of new telephone equipment and Model I automation when it becomes available. Model II graphics for the FSS are so far downstream as to be irrelevant at this point. The FAA must now take steps to buy or lease commercially available color weather graphics displays for the FSS briefer.

We can say little about the Interim Voice Response System (IVRS), another "moving target", until we finally see it in operation. A nationwide telephone voice response system has been badly needed for some time to offload the FSS briefer; if IVRS works, consideration should be given to expanding the contract to cover more territory. If IVRS does not work, there are similar commercial systems available for government procurement.

However, it is essential that the aviation user community actively push to make "near-term" DUAT service a reality. We simply cannot be asked to wait until 1991 for nationwide DUAT coverage through Model II. For one thing, Model II funding

is doubtful at this point, FSS consolidation is under way, and private sector stands ready today to provide this important service for the FAA.

After seemingly endless debate and study, we are pleased to see that the FAA is apparently moving off dead center with regards to a DUAT service. We concur with the FAA's "Proposed Near-Term DUAT Policy" which surfaced during a December 17 meeting of the FAA Administrator with the National Avcomp's Council (NAC). We also agree with NAC's approach to providing FAA DUAT services, which would be for monthly FAA reimbursement for any vendor delivering the basic FAA DUAT "product".

The one deficiency so far in the proposed DUAT policy is the omission of financial incentives for state and local governments to provide "pilot self briefing facility" hardware. The FAA's FSS Modernization Plan of 1978 originally called for some 3500 airport-located Pilot Self Briefing Terminals (PSBT) to access FAA-provided data. Because pilots cannot take their home and office terminals with them, the FAA must complete the loop and stimulate the equipage of airports with DUAT terminals. Minnesota and Wisconsin, of course, got tired of waiting for the FAA to act and went to some trouble to provide their own DUAT service.

Thunderstorms

The last topic to address is detection, warning, and avoidance of thunderstorms. We have already mentioned the unmet need of uplinking ground-based radar data to properly equipped aircraft in flight. But the majority of general aviation aircraft, which will not have either a cockpit weather display system (CWDS) or airborne radar, will have to rely on good preflight briefings and in-flight advisories to avoid thunderstorms.

We have the following recommendations to improve the severe weather safety situation:

- All FSS must be equipped with color weather radar displays. These data can even be provided now through personal computer terminals with proper software. It is unconscionable that eventual FSS consolidation be used as an excuse to keep briefers and pilots in the dark. Storm Detection (SD) reports are a poor substitute for radar imagery. The concept of equipping only 44 of 61 Automated FSS hubs with RRWDS radar displays is completely unacceptable.
- We agree with the House Oversight Subcommittee that TRACONs should have the benefits of color weather radar. It is encouraging to see that color weather radar displays will be evaluated at the Memphis, Kansas City, and Boston towers.

- FAA, Air Force, and NWS should continue NEXRAD development, but should devote attention to commercially available terminal Doppler radars that are ready for testing now.
- We know of few pilots or controllers who place much faith in Low-Level Wind Shear Alert System (LLWSAS); its funding should be shifted to terminal Doppler radar procurement for towered airports.
- For all of its advantages, ground-based weather radar should be backed up by lightning detection systems. There are many available now that could be added later to existing AWOS units. In the meantime, we are encouraged by the interagency cooperation that has enabled Bureau of Land Management/U. S. Forest Service lightning detection networks to be fed into the National Severe Storms Forecast Center in Kansas City.

Conclusions

While AOPA and general aviation, as a whole, continue to have both high expectations and frustrations with the aviation weather system, we realize that cooperation among all sectors is necessary to improve the situation. While those in government, married to certain long-term projects, may not really want to hear about alternative solutions to our problems, as aviation consumer advocates, we owe our members nothing less. Most of the programs proposed for aviation weather needs are adequate and acceptable, and we must get on with them.

**PANEL DISCUSSION
FOLLOWING OVERVIEW PRESENTATIONS**

Question to Doug Lundgren, AOPA: Mike Tomlinson, NWS

One of the statements in your prepared comments said that the area and terminal forecasts needed some work, and you spoke particularly about probability of fog. Can you be a little more specific? Are you speaking, for instance, in terms of warranting information about probabilities rather than having conditional statements taken out? Also, what problems do you, as the user, see with the area forecasts?

Response: Doug Lundgren

Of course, there is a whole lot of debate about the value of conditional statements, i.e., “the chance of,” “occasionally,” etc. From a general-aviation standpoint, we can live with conditional statements. The airlines, of course, get snagged by them because they have to plan for more fuel, and so forth. We don’t mind “the chance of,” but sometimes we really do have to define the probabilities a little more. I cannot quantify exactly what we are looking for except to say that there are just so many times when the fog doesn’t materialize, or it does materialize and we don’t expect it. Not being a meteorologist, I can only wonder, in general, how we can improve these things. Is it a matter of more points or better models. I really don’t know. I simply get feedback in letters from folks saying of the phenomena I mentioned, it is just not making the mark. Either it is worse than predicted, or better than predicted; and either I cancel the trip unnecessarily, or I take a trip and get “bashed.” So I cannot be too specific at this point with what I have in hand, except that perhaps we could pass the letters on to you directly and you can try to figure out how we can take care of the phenomena.

Question to Steve Short, NWS: Jim Sullivan, US Air

Will the demonstration automated reporting system have a phone dial-in capability as do some of those now in operation?

Response: Steve Short

The answer is no. The reason for that is we are restricting the use of the data initially until such time that we are sure that the system is functioning very well and we have no problems. Then, at that time, there may be some external use available, but not initially.

Question to Steve Short, NWS: John Prodan, AV-CON

What is the radius of acceptability of your area weather? In other words, if

you have clouds over the hills in the neighborhood with visibility dropping strongly, would your system be able to pick that up, and in what radius?

Response: Steve Short

The system should be able to detect ceiling conditions. But, again, it would be dependent upon a site survey, where we really need more than one ceilometer. For example, the airport in San Francisco will have multiple ceilometer installations a number of miles apart (separated approximately five or six miles apart). So the observations that would be acquired from there (i.e., low stratus; broken stratus) should be representative over a fairly large distance. We have to look at particular orographic conditions that might influence that, and there are a host of considerations to take place there, as visibility. In the southwest, where there are homogeneous conditions, a single sensor would be sufficient and representative of a large area. If that's not the case, we would need either multiple visibility sensors a number of miles apart, or someone such as a weather service observer or air traffic controller to override and put in precise information. But procedures would have to be established and instituted along with the system.

To answer your question specifically, we would expect the visibility of the observations to be representative since our visibility range is 8+ miles.

Question to Steve Short: Norm Crabill, NASA/LaRC

In your discussion of your automated observation system, you said that the data would be brought into a regional office of some kind; i.e., I believe you called it the "war room." Can you discuss what kind of real-time displays are envisioned for this, if I have the concept right?

Response: Steve Short

Yes, I can. Initially, what we will be doing with automation is simply replicating what is done right now. No real change is expected, except for the fact that real-time data will be available at that airport in the tower. That will change, though, in two cases. 1) When the Weather Service implements AWIPS-90 (Advanced Weather Interactive Processing System of the 1990's), as I referred to as the "war room," there will be an effective work station for the forecaster to have, at ready access, real-time data (e.g., satellite and radar imagery, surface observations) flowing in from the area of responsibility for that forecast office. Again, that is a future environment for the early 1990's. The AWIPS-90 Program should be essentially completed by 1993-94 coupled with reorganization changes of some sort. 2) Analogously, within the FAA at the Air Control Facility with the CWSU, they envision a relatively similar operation. Again, that is a few years hence.

Observations from all the surface automation sources in the weather forecast area, which will be a geographic area comprising typically the size of half a state, will be ingested.

You may be familiar with the PROFS work effort, which is basically the precursor and the prototype for the future operations. It is now being done on an experimental basis at PROFS in Boulder. There will be a real-time exchange of data both from our forecast operations and the CWSU.

Question to Doug Lundgren:

When you access private source units like the State of Minnesota has put in several of the airports, do you have to pay for that or is it state supported?

Response: Doug Lundgren

It is state supported, and the pilots pay for it. There are about six different options which the FAA has come up with in their discussions with the private sector which would involve some sort of government reimbursement to the private sector. Whenever I say "private sector" in this context, I am not advocating that we abandon the government role in providing this service. The government has a fiscal responsibility in that it is still collecting our user taxes to provide that service. The State of Minnesota program is funded by a fairly hefty registration tax on aircraft, a state airmen tax, a fuel fillage fee, and various taxes on airline passengers, I believe. There is a dedicated aviation trust fund in that state. They are running the entire 50-terminal direct user access program with about \$300,000 per year in operations money from a private contractor.

Question to Steve Short:

With all the automated stations being installed, where are we going to find the circuit time to send this information out? Most of the Weather Service circuits now are absolutely saturated, and I cannot see this machine putting out a special every 30 seconds.

Response: Steve Short

That is a real good question. The quasi-continuous observations flowing to the forecast office in the future will be during watch and warning periods. Other than these periods, it will be hourly or special observations as are done now. The real-time flow of data from surface observations is dependent upon the communications upgrade which is part and parcel of our AWIPS-90 Program and on the companion system for the FAA.

Question to Steve Short: Leo Boyd, CLB Assoc.

May I suggest that a lot of this clogged circuitry that you are talking about in data transmission is going to weather and flight service stations? Could it be reprioritized so that the more essential data get in there and in the time remaining the interagency communications take the hindmost?

Response: Steve Short

Let me see if I understand the question. Right now we, of course, generate hourly and special weather observations, and I don't think we have any appreciable delay that I am aware of there. That does not permit the real quantum increase in data traffic that will take place with the quasi-continuous data stream from all of the automated sources. That's not a question of reprioritizing, but a total upgrade of communication systems. There are a number of phases planned with that, but it is really dependent upon that upgrade. We envision that to be in the 1990's.

Question (cont.): Leo Boyd

You are putting in some flight service stations, with the CRT's in order to pull up certain data, but then using 1947-type slow-speed printers which could have been upgraded a long time ago.

Response: Steve Short

In answer to flight service stations, I will have to defer that to Doug Lundgren.

Response: Doug Lundgren

I have been doing a little research as to how the FSS automation network is going to fare with some of the budget cuts and perhaps project slippages that we're looking at; obviously we want it to succeed. Particularly, I asked the FSAS program office whether Model-1 automation is alphanumeric retrieval and input to the specialist for just weather and flight plans; and if that could be run with Service-A circuits, or whether it needed NADIN. The response was that Model-1, the basic FSS automation, can use existing medium-speed Service-A; however, to get the full benefit of the FSS automation program through Model-2, you need the high-speed data. The private sector, of course, does not even deal with medium-speed anymore for similar capabilities. Yes, if NADIN is cut, basic Model-1 automation can succeed, apparently; but after that, it is questionable as to whether Model-2 can do anything without high-speed data.

Question to Don Beran: Tom Genz, Northwest Airlines

My question would be what your projections are for the accuracy of this at high altitude and what kinds of maximum altitudes are we talking about? For example, what degree of accuracy is there between 30,000–45,000 ft with the profiler?

Response: Don Beran

The accuracy of the system is ± 1 m/sec. I was not joking when I said that we do not like to compare this with radiosondes because the profiler is so much better. We measure the wind directly above the site, not downwind as the radiosonde does. We have many comparisons with radiosonde, and we compare very well. We now have two profilers (a 50 MHz and a 405 MHz) sitting side-by-side at Platteville, operating simultaneously. I can show you the wind fields measured by those two totally independent systems. They overlay each other and you cannot see any difference in the winds from the two systems. In my opinion, that is validation that we are measuring the wind very well. To go a little further, we have also compared the radial velocities with the Doppler CO_2 -pulsed coherent lidar system, and obtained similar excellent results. There is no question in my mind that we are measuring the wind with more accuracy than it is measured with the radiosonde. On the 50 MHz systems, we see ranges up to approximately 17 to 18 km, which is above the height you mentioned. On the 405 MHz systems, we see good performance up to 13 or 14 km, which is in the approximate range you asked about.

Question to Don Beran: Louis Duncan, U.S. Army/Atmospheric Science Laboratory

How long does it actually take you to get a wind profile by using the system and the data reduction?

Response: Don Beran

The data processing system we use requires about an hour because the two beams require long average times to reduce the impact of unmeasured vertical velocities. For a little extra cost for a third vertical beam, the profiler should be capable of taking the wind profile about every two minutes. The present data processing system is not capable of this speed.

Question to Don Beran: Bill Hall, OFCM

I was simply curious about finances. Can you give us some idea of the cost factor per profiler and whether or not your proposed network is funded?

Response: Don Beran

The hardware cost for each system has been about \$200,000. We are currently funded at \$6 million/year for putting in the network. These funds are for the installation, operation, maintenance, and testing of that network. We have developed cost estimates for a commercial version. These units will probably cost about \$300,000 to \$400,000 for the wind profiler alone. That's the best estimate I can give you. We will not know the exact cost until the lowest bidder arrives to tell us what it will be.

If you also set up a temperature profiling system, you would probably not put a radiometer at each of the wind profiler sites. We believe you can use the high-resolution wind network to derive the temperature profile, having perhaps one temperature profiler for every ten stations, and also combine it with the satellite information to have a complete network. The cost of an individual thermodynamic profiler would be of the same order, i.e., \$200,000 to \$300,000 per copy.

Question (cont.): Bill Hall

Are you suggesting that we may eventually reach a point where we would not have a network of radiosondes?

Response: Don Beran

Yes, I think that will occur in perhaps the next 20–30 years. I think it will eventually happen; but I am certainly not going to say that it is going to happen very soon. I think we would be foolish to take any of the radiosondes out of commission now because we still need all of the meteorological data we can get and then some. I suspect that we will see a transition to a first stage when the profiler will supplement the radiosonde network. The profiler could eventually replace the radiosonde completely. When you get to that point, remember those cost figures I gave you of \$200 to \$300 per launch, I believe it costs about \$200,000 to \$300,000 per year to operate a radiosonde station. So you would pay for the capital costs in only three or four years for a complete profiler system that would replace the radiosonde network.

Question to Don Beran: Bob Dean, USAF

Don, you have brought up some interesting points about your profilers. You mainly dwelt on the wind profiler, but I would like to address a question on the radiometric profiler. What do you perceive will be the impact of the observations from your new profiler compared to the data base which we now have, for example, the cloud-free line of sight? For obvious reasons, the Air Force is interested in air-to-ground, ground-to-air, and air-to-air combat. What will your new profiler do with respect to our current data base on cloud-free line of sight?

Response: Don Beran

I suspect that you should continue to use the satellite. It is probably the best cloud-free line of sight device found anywhere, certainly in terms of forecasting cloud incidents over friendly territory. However, I'm guessing that you probably want cloud-free line of sight over unfriendly territory. It is doubtful that the enemy will provide this kind of information for you in wartime. I don't know. That would be an interesting speculation in itself. Close to this topic, it is interesting what you can do with clouds and moisture. I didn't mention this in the talk, but the radiometer has a two-channel radiometer which is part of the total system, and has the ability to see the total liquid water and water vapor content above the instrument. In fact, it appears that it is a very good device for detecting conditions which are conducive to aircraft icing. It is also being used in a number of cloud physics experiments where they are looking at seeding of clouds. So, it does have some relationship with clouds and moisture in the atmosphere, and I suspect that the more information we get over friendly territory where you have definitive information, you will be able to make better forecasts. I believe the satellite is the only way you will have for a long time to get much information over unfriendly territory.

Question to Colin Flood, Bracknell Met. Off.: Bob Dean

Since you are talking about friendly/unfriendly territory, I have a question for Colin Flood. You mentioned the World Forecast Center in your talk, and I would like for him to make some comments on whether or not the Warsaw-Pact countries contribute to that particular center.

Response: Colin Flood

I am not actually sure of the correct answer to that question. The European Center is funded by a lot of European nations, and it certainly goes wider than the NATO countries. So, as far as I know, countries like East Germany, Poland, etc., do not contribute to the program, but products from the European Center do get distributed around the world on the world trunk circuits. Although the main body of the products from the European Center are contained within Europe by the National Weather Services within Europe, a limited number of products are distributed around the world on the world trunk circuits (i.e., basically 500 mb height in surface pressure out to about six days). I'm afraid I'm not able to answer your question exactly about the Warsaw-Pact countries. Does that help?

Question to John Garthner, FNOC: Doug Lundgren, AOPA

Are the data from your system available on ships as well as aircraft, or is a dedicated land line required?

Response: John Garthner

Currently the system uses a dedicated land line. Ships can receive the service with the Naval message. For example, if a carrier was planning a fly-off perhaps across the Atlantic or Pacific, a message may be sent several days prior to fly-off asking for the position of fly-off. Perhaps the particular latitude/longitude, number of aircraft flying, and destination are provided. We would then simulate the flights of these aircraft and get the data back to them probably within about 12 hours prior to fly-off.

Question (cont.): Doug Lundgren

But it does make you think about having satellite transmission down to the carrier deck, doesn't it?

Response: John Garthner

Yes, that would be outstanding, sir.

Question to John Garthner: Steve Fuller, EMI Aerodata

Why are you using Jeppesen data rather than MOS data for your airspace data?

Response: John Garthner

For the air route structure, Jeppesen data is the only data currently available in a digitized format.

Question to John Garthner: Dick Van Gemert, Xerox Corporation

Do you have the ability to load in the operating cost base to make the trade-offs of flight time versus rotables versus fuel to get the least cost routings?

Response: John Garthner

We have not done that. We have done some guesswork trying to be as conservative as possible in taking everything into consideration: i.e., communications costs, salaries, computer usage, etc. We feel very conservatively that we saved the Navy between \$11-12 million in 1984.

Question to John Garthner: Ed Harrison, USN, Pentagon

What method do you have of incorporating the weather warning data into the model? I know that is a significant weakness.

Response: John Garthner

I have stayed away from incorporating weather warnings into the model for a couple of reasons: 1) I am not sure I could get it in fast enough or accurately enough (since it is an on-line system) to cover everyone and everything. You must realize that our model runs every 12 hours, so flight plans are sometimes run shortly after a model is run, expecting a take off within the next 12 hours. A weather warning could, in fact, occur that would not be in the system, and I would not want someone to take off thinking there is none when possibly there is. As an aviator, I feel that if you have a chance to go by a desk and talk to a human before flying, that is the best thing to do.

SECTION IV BANQUET PRESENTATION

Mr. Dub Yarbrough
Staggerwing Museum Foundation

Introduction

I am really pleased that Dub Yarbrough will discuss the Staggerwing Museum. Dub is the Founder of the Staggerwing Club which was established in Atlanta, Georgia, in 1962. He held the position of President of the Club from 1962 to 1973. I know that many of you have frequently asked about the Staggerwing Museum and have wanted a chance to see it. Some of you have had an opportunity in the past to go out and see it. We really appreciate the fact that Dub opened it for us so that we could take a tour.

In 1973, Dub also founded the Staggerwing Museum in Tullahoma, Tennessee, and he held the position of President from 1973 to 1982. He is currently a Trustee of the Staggerwing Museum Foundation. He has many ties to some of you people, because in 1971, he retired as a Navy Captain after serving 30 years combined active and reserve duty during which he was a pilot.

During his civilian career, Dub was employed by Lockheed in the Flight Test Division for 21 years. After all that activity in the aviation community, he currently serves as Vice-President of Worth Sporting Company in Tullahoma, and has been doing that for twelve years now. We are pleased to have him discuss the museum.

Mr. Dub Yarbrough

The Staggerwing Museum started many years ago. I would like to bring you up-to-date on its history because it is very interesting to see where we are today and where we were back in the 1920's. Walter Beech was born in Pulaski, Tennessee, and some of his relatives wound up at Beech over the years. Ed Burns, who was a recent President of Beech, was one of them. Walter Beech, Lloyd Steerman, Clyde Cessna and Matty Laird are all names that people in the aviation business know and understand very well. They all got together in the 1920's and started the Travel Air Company in Wichita, Kansas. Walter Beech sold the Travel Air Company to Curtis Wright in 1930. In 1931, he came back to Wichita and started the Beech Aircraft Company. In December 1932, the first Staggerwing Beech aircraft was produced. They wanted an airplane which could get good speed (close to 200 mph), and which could land at about 50-60 mph on unimproved fields and roads around oil derricks in Oklahoma and Texas. So, Wichita businessmen put some money into the company, and Walter built the airplane.

That first aircraft was built in 1932 and it crashed in New York around 1936.

A young man in California dug up that airplane, which was still covered, and the fuselage was in excellent shape when he got it out of the ground. He has the parts and is in the process of restoring this airplane. In about two years it will be displayed at our museum. Serial No. 3 was the first retractable-gear airplane. In the museum, we have the wind tunnel model and the miniature structural model of the retractable system on that airplane. The Serial No. 3 airplane is currently in the FAA Museum in Oshkosh, Wisconsin.

Beech manufactured 840 Staggerwing Beech Aircraft. At the present time, we have about 150 remaining on the FAA register as licensed airplanes (110 of them are flying today and 40 are currently in restoration). I have always said that behind every successful man there is a successful woman, and behind our whole program there was one woman who stood out more than anyone else. That woman's name was Louise Thaden. Louise started flying in the 1920's, and she won the first women's air derby from California to Cleveland, Ohio in 1929. They stopped about every six hours all the way across the country. That was the first powder-puff derby. Then she turned around in 1936 and won the Bendix Trophy flying from New York to California in a Staggerwing Beech. That turned things around at Beech. Beech Aircraft asked Louise if she would fly the race because Mr. Bendix was going to award a \$3,000 check for the first woman to complete the Bendix Race. Not only did she receive the \$3,000 for the first woman to complete the Bendix, she also received the \$7,000 check for winning the race.

That put Beech rolling. In the first five years of production at Beech, from 1932 to 1936, they had produced 76 aircraft. Within the next nine years they produced 764 aircraft plus they were producing the Model 18 Twin Beech, with which many of you are familiar. That large quantity, 764 aircraft, was built mainly for the military during World War II. Over 600 Model D-17S aircraft which used a Pratt and Whitney engine were built. After the war, they built 20 Staggerwings and called them the G17S, which is really the Cadillac of aircraft. In 1962 I was fortunate to obtain a G17S Serial 3. At that time, I was in Flight Test at Lockheed. In 1944, I was an instructor in Stearmans at Bunker Hill, Indiana, in the Navy, and I had a chance to fly a GB-2, which was a Staggerwing Beech.

After I picked up the G17S Serial 3, which was in beautiful condition, I wrote a group of 20 people to see if we could get together and keep this airplane going, share our knowledge and parts, and start an organization. After the first year, we had brought in many others. Bob Smith with the FAA Office in Atlanta came out in 1967 with a book entitled, "Staggerwing." That book gave us quite a boost as far as our club was concerned. In 1967, Olive Ann Beech asked the club to come to Wichita for a homecoming. We did and had a fine time.

Olive Ann Beech was delighted when she came to Tullahoma and saw what

we were doing. We have been completely at arm's length with Beech Aircraft. We have never had to ask them for anything whatsoever. Everything in our Museum has been done by our 350 members.

In 1973, I had been in Tullahoma one year and we had our first convention. I asked Louise Thaden to come over to be our Guest Speaker. She accepted our invitation and pleased everyone with her past accomplishments. She held the endurance record, altitude record, speed record and solo endurance record all at one time. She was the only woman to receive the Harmon Trophy which came from the President of the United States as the most outstanding aviatrix in this country. She is a very humble and family-oriented person. While she was here, she suggested we gather some technical information through bulletins, drawings, etc., and set up a library or museum. The next year we dedicated the Thaden Library and Building. We have 340 members in the foundation. These members include farmers, corporate presidents, airline pilots, FAA people, movie stars and many others in this organization, but when they all get together, they simply have a lot of fun with the airplane. To be a member of the foundation, you do not have to own an airplane; just enjoy people. Communication is the essence of our whole program. We have a convention each year here in Tullahoma, with the exception of every fifth year when we go back to Wichita.

Raytheon has bought Beech Aircraft, so we do not know whether or not we will be going back to Beech as all of our ties have been lost. However, Raytheon has told us they would like for us to come back in 1987. This is not just a party program as far as the conventions are concerned. We have seminars, maintenance demonstrations (by dismantling an aircraft for its annual inspection), safety flights, and biannual check rides for our members given by our five pilots. If you purchase a Staggerwing and want to learn to fly it safely, one of these same five pilots will check you out in the aircraft and stay with you until you are ready to go. We have become so close, like a family, and when we lose someone, it hurts; so we go the long yard, as far as maintenance is concerned. If someone comes into our new maintenance building and does not know much about his airplane, we will run gear checks and show him what he needs to look at because you do not simply order another part for one of those aircraft. Most replacements parts have to be made.

In 1946, the price of the new aircraft was \$29,000. I bought a used Staggerwing in 1960 and paid \$2,700. Last year at our convention, Duke Vincent paid \$150,000 for a Staggerwing and took it back to California.

The museum is financially sound. In the report given at our Trustees' meeting in San Diego this year, our museum value was right at \$1 million. This has been accomplished in the last 13 years. At the present time, our indebtedness is approximately \$24,000. We have over \$500,000 in an endowment fund and in negotiable

securities, so we do not have any problems and ask no one for help. It is strictly voluntary. We would love to have you come back and visit us again. The museum is open by appointment, and in the summer it is open each weekend. Are there questions that I might answer for you at this time?

Question from the floor: Can you tell us the smallest and largest engines ever installed in that airplane?

Response: Mr. Yarbrough: Yes, the 245 HP Jake was the smallest and it was in Serial 3. The largest was a 600 HP installed in one of the fixed-gear airplanes used in the McPhearson Race. They are all four-place aircraft with wood-framed wings and steel fuselages. I used to go to San Diego from Atlanta, and I would make one stop for gas in El Paso, cruising at about 192 mph at 8,000 feet, which is about the best altitude for the aircraft. Are there any other questions?

Question from the floor: What did the Army use the Beech aircraft for? Was it observation or transport?

Response: Mr. Yarbrough: The Air Force and Navy used them as utility aircraft. Each Commanding Officer of each Naval Air Station and Army Air Corps post had one for his own use. It was not a training airplane. It was a lovely airplane in the air, but a bear on the ground, as Louise Thaden said. They are a little unpredictable on the ground, but a beautiful airplane in the air.

I remember an old gentleman in North Carolina called me about a D-Model airplane he wanted to sell. When I was in that area, I called him and asked if I could visit and take a look at his airplane. He came in to meet me and we went out to his farm. In the middle of the cotton patch in an old wooden hangar was the airplane. I looked around and didn't see a runway, so I asked, "Where is the runway?" He answered, "Well, it's right out there." I asked him how long the runway was and he told me it was 1,000 feet. I said, "Well, for Pete's sake, that's pretty short, and there's a fence at one end and good approaches on the other." He said, "Yea, I had to extend it to 1,000 feet because I started coming in here at night."

It's a very good performing airplane; but it's back to a grassroots-type of flying.

Question from the floor: What was your average cruise altitude and maximum altitude on the Staggerwing?

Response: Mr. Yarbrough: The optimum altitude is anywhere from 8,000 to 10,000 feet. Of course for anything above 12,000 feet, you need to be on oxygen. You can hold cruising manifold pressure of 26 at 10,000 feet. The range is 900 miles with an average of 20-22 gallons per hour. On the G-Model, we carried 192 gallons of gas.

SECTION V
IMPROMPTU PRESENTATIONS

AIRCRAFT/LIDAR TURBULENCE COMPARISON

Kao-Huah Huang
FWG Associates, Inc.

Introduction

A field test was carried out to compare lidar-measured winds and turbulence with both aircraft measurements and tower array measurements. The instrumentation consisted of the NASA/MSFC (NASA/Marshall Space Flight Center) lidar (Bilbro and Vaughan 1978), the NASA B-57B instrumented aircraft (Campbell et al. 1983), and the NASA/MSFC Atmospheric Boundary Layer Facility eight-tower array (Frost and Lin 1983). The experiment called for flights on May 10, 11, and 12, 1983. The May 12 experiment is reported here. Details on the other flights are given in Frost and Huang (1983).

On May 12, 1983, the lidar was fixed at a 6° vertical angle and at 52° azimuthal from true north, see Figure 1. The aircraft then flew approach paths at an approximate 4° glide slope parallel to the radar beam. Eight successive runs or approach paths were flown at approximately 5-minute intervals.

The emphasis of the study was to compare Doppler lidar-measured winds and turbulence with aircraft measurements. Primarily the study was to compare aircraft-measured turbulence intensities with the lidar second moment or spectral width data. Unfortunately, this aspect of the study was not particularly successful in view of the fact that only three range bins (Range Bins 9, 10, and 11) had high enough signal-to-noise ratios for the second moments to be successfully computed. Secondly, the values were computed in the range from 1.26 to 2.51 m/s, which is a factor of ten larger than those values measured either with the aircraft or with the tower array.

The field study was successful, however, in that it: 1) provided a unique set of data for comparing mean wind speed values; 2) revealed that turbulence intensities computed from the Doppler-measured wind speed time histories (i.e., 300 m spatially averaged values) agree remarkably well with the point measurement from the aircraft; and 3) showed that turbulence spectra calculated both from the time histories of the lidar-measured winds, and the aircraft-measured winds, were in very good agreement.

Finally, an extremely interesting atmospheric boundary-layer event evolved during the time period (16:42–17:28 Z) of the May 12 test. This event was clearly recorded by both the aircraft instrumentation and the lidar. Because both systems accurately recorded this boundary-layer event, it is believed that considerable

reliability in the lidar mean winds is demonstrated.

This report presents a detailed analysis of the winds measured during the evolution of the atmospheric boundary layer occurring on May 12 and emphasizes the validation of the Doppler lidar remote measurements with the in situ aircraft measurements.

Instrumentation and Data

A complete description of the NASA/MSFC Doppler lidar is provided in Bilbro and Vaughan (1978), Jeffreys and Bilbro (1975), and Lee (1982). The lidar is a variably pulsed CO_2 Doppler lidar. During this study, a 2- μs -pulsed lidar was used. The Doppler measures the component of the wind along the lidar beam, i.e., the radial wind speed component. The measurements are representative of the average wind speed within a conical trapezoid of 300 m in length and of diameter associated with the diverging lidar beam width. Figure 1 illustrates the lidar beam and shows the location of each individual range bin for which radial wind speed components are measured. The figure also illustrates the position of the beam relative to the terrain contour cross section.

The lidar data were received from NASA/MSFC in digitized format on magnetic tapes. Typical time histories of the data provided on the tape, which includes amplitude of the signal in decibels, radial wind velocity in meters per second (m/s), and second moment (lidar width) data for turbulence intensities in meters per second, are shown in Figure 2 for the May 10 and 12 field tests, respectively.

Figure 3 is a plot of 150 sequential values of wind velocity from the May 12 data tape. The figure illustrates approximately 75 seconds of data. It is clear from the figure that data in Range Bins 1 through 8 are very noisy due to ground clutter and do not provide useful data. Also, the figure shows that beyond approximately Range Bin 21, the signal-to-noise ratio becomes excessive and velocities measured above this altitude are not meaningful. Thus, for the May 12 field test, only radial wind speed values from Range Bin 9 (460 m msl) to Range Bin 21 (840 m msl) were selected for analysis.

Data from the B-57B flights consisted of 80 variables in a 60-bit integer format. The original raw data were sampled at 200 cycles per second. However, they were provided from NASA Langley Research Center in engineering units at 40 samples per second. Although all the variables necessary to resolve the wind speed components by backing out the aircraft motion are available, the data from NASA Langley provided pre-computed gust velocities. These were used throughout the analysis.

Figure 1 shows typical flight paths relative to the lidar beam. Because of un-

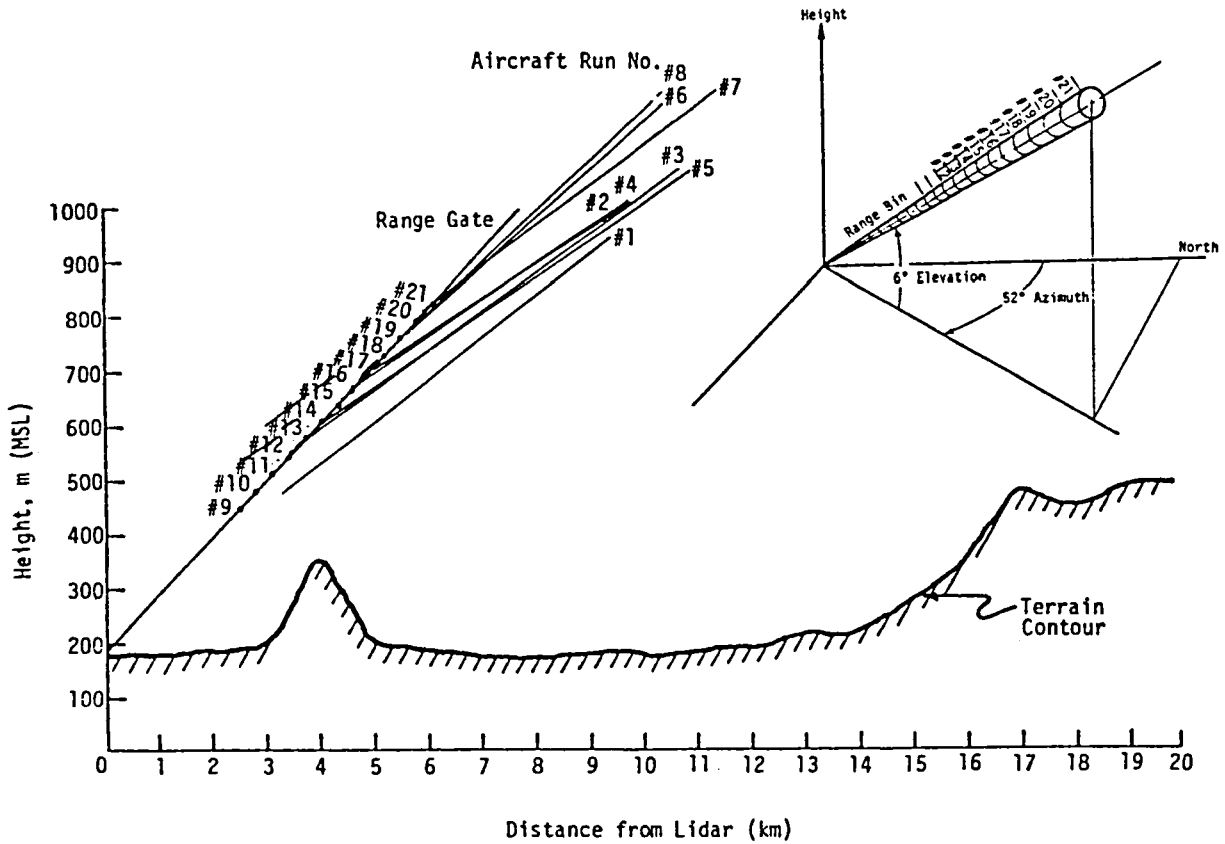

Figure 1. Lidar beam range bins at 6° vertical and 52° azimuth and relative positions of aircraft flight paths.

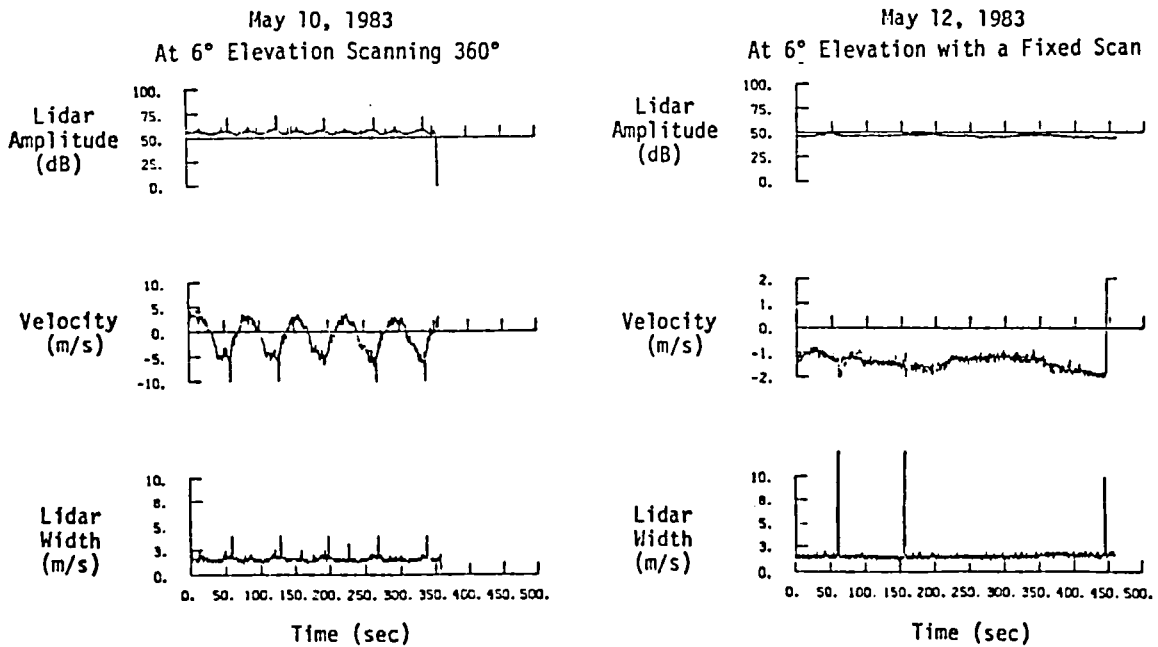

Figure 2. Typical time series of lidar amplitude, velocity, and spectrum width for Range Bin 9.

usual drift in the INS, the latitude and longitude measurements are questionable. Thus the exact position of the aircraft relative to the lidar beam in a horizontal plane is not known precisely. Ground-based personnel, however, observed the aircraft to approach essentially along the position of the lidar beam. The aircraft height, however, at any instant is accurately measured and is, in fact, the most important value of aircraft position for comparing the wind speeds measured by the two systems.

Figure 4 is a three-dimensional plot of the horizontal winds measured with the aircraft along each flight path and staggered in time. In this plot the wind vectors illustrated are values averaged over a 300 m section along the flight path. One observes the growth of the inversion layer, which was developing at approximately 600 m above the ground, over the 30-minute period during which the eight flights were carried out.

Comparison of Lidar Measurements with Aircraft Measurements

Comparison of the measurements of mean wind with the lidar and with the aircraft system is described in this section. The aircraft-measured wind speeds were first transformed to the time-dependent components along a 6° line of sight and at 52° azimuthal true north, i.e., along the lidar beam.

The aircraft-measured wind speeds were then averaged with time over a period corresponding to the length of time required for the aircraft to traverse the 300-m range bins along the flight path. Two approaches to carrying out this averaging technique were investigated. One was to assume vertical homogeneity in the flow field. The averaging process for the aircraft data was then carried out as illustrated in Figure 5a. The alternate technique was to average the wind assuming homogeneity in the horizontal direction. This approach is illustrated in Figure 5b.

A third effect taken into account when comparing data from the two systems was to assure that the winds measured with lidar and with the aircraft were measured in the same time period. The run times associated with each flight path were, therefore, overlaid on the lidar-measured winds as illustrated in Figure 6. The lidar data are sampled in each bin at approximately 0.5-second intervals. The segment of the lidar wind speed time history associated with the time period in which the aircraft was passing through or parallel to that range bin was then averaged.

Figure 7 compares the lidar-measured winds averaged over the time period, as described above, with the aircraft-measured winds averaged over the corresponding 300-m section assuming vertical homogeneity. Horizontal homogeneity showed similar results. One observes very good agreement between the lidar measurements and aircraft measurements although the data are consistently higher for the lidar

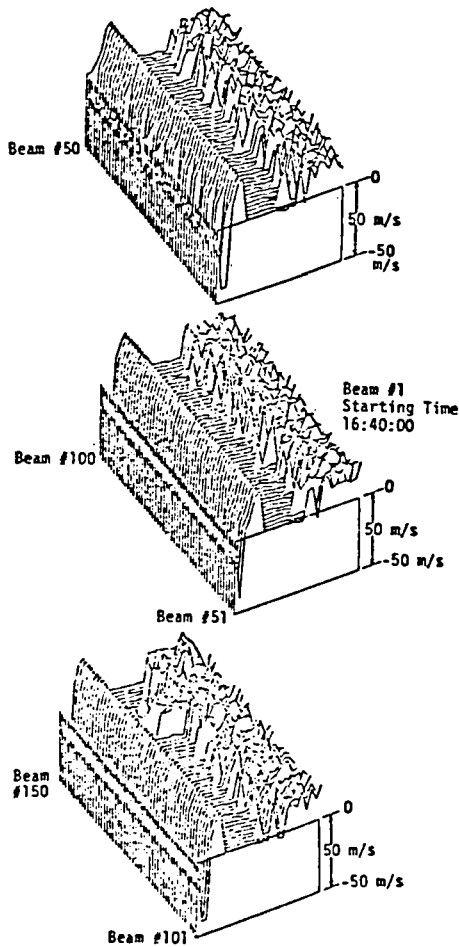

Figure 3. Sample of velocity data along the lidar beam for 150 sequential beams (represents 75 seconds of data).

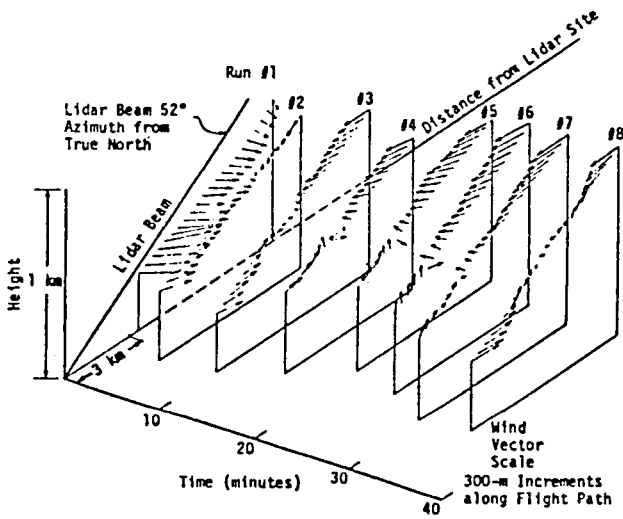
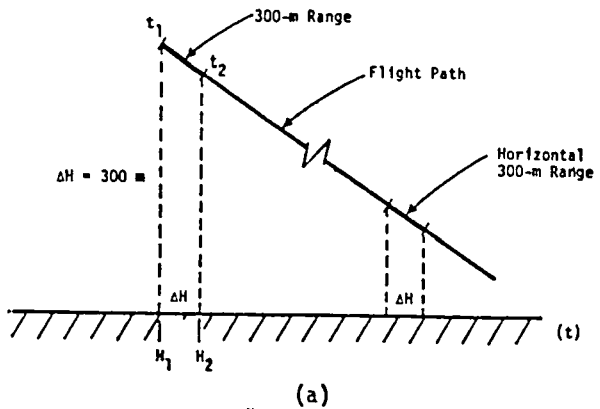

Figure 4. Horizontal wind vectors along B-57B flight path (May 12, 1983).



$$\bar{W} = \frac{1}{(N_2 - N_1 + 1)} \sum_{i=N_1}^{N_2} w_i$$

$$N_1 = \frac{t_1 - t_0}{0.025} \quad N_2 = \frac{t_2 - t_0}{0.025}$$

t_0 = beginning of each run
 t_1 = time airplane enters each horizontal range at N_1
 t_2 = time airplane leaves each horizontal range at N_2

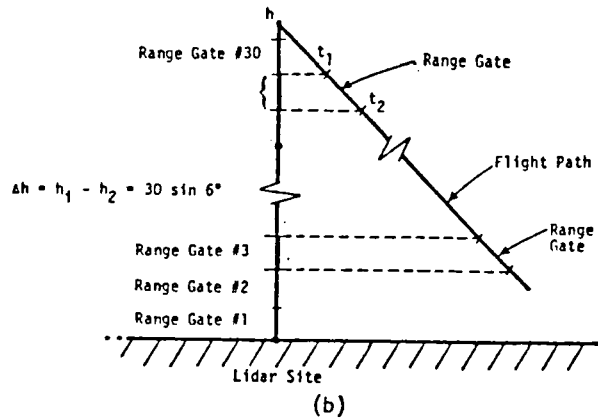
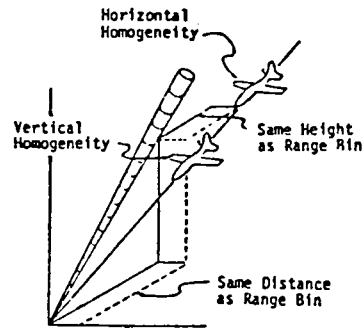

$$\bar{W} = \frac{1}{(N_2 - N_1 + 1)} \sum_{i=N_1}^{N_2} w_i$$

$$N_1 = \frac{t_1 - t_0}{0.025} \quad N_2 = \frac{t_2 - t_0}{0.025}$$

t_0 = beginning of each run
 t_1 = time airplane enters each range gate at height h_1
 t_2 = time airplane leaves each range gate at height h_2

Figure 5. Evaluation procedure for averaging B-57B wind for each range bin.

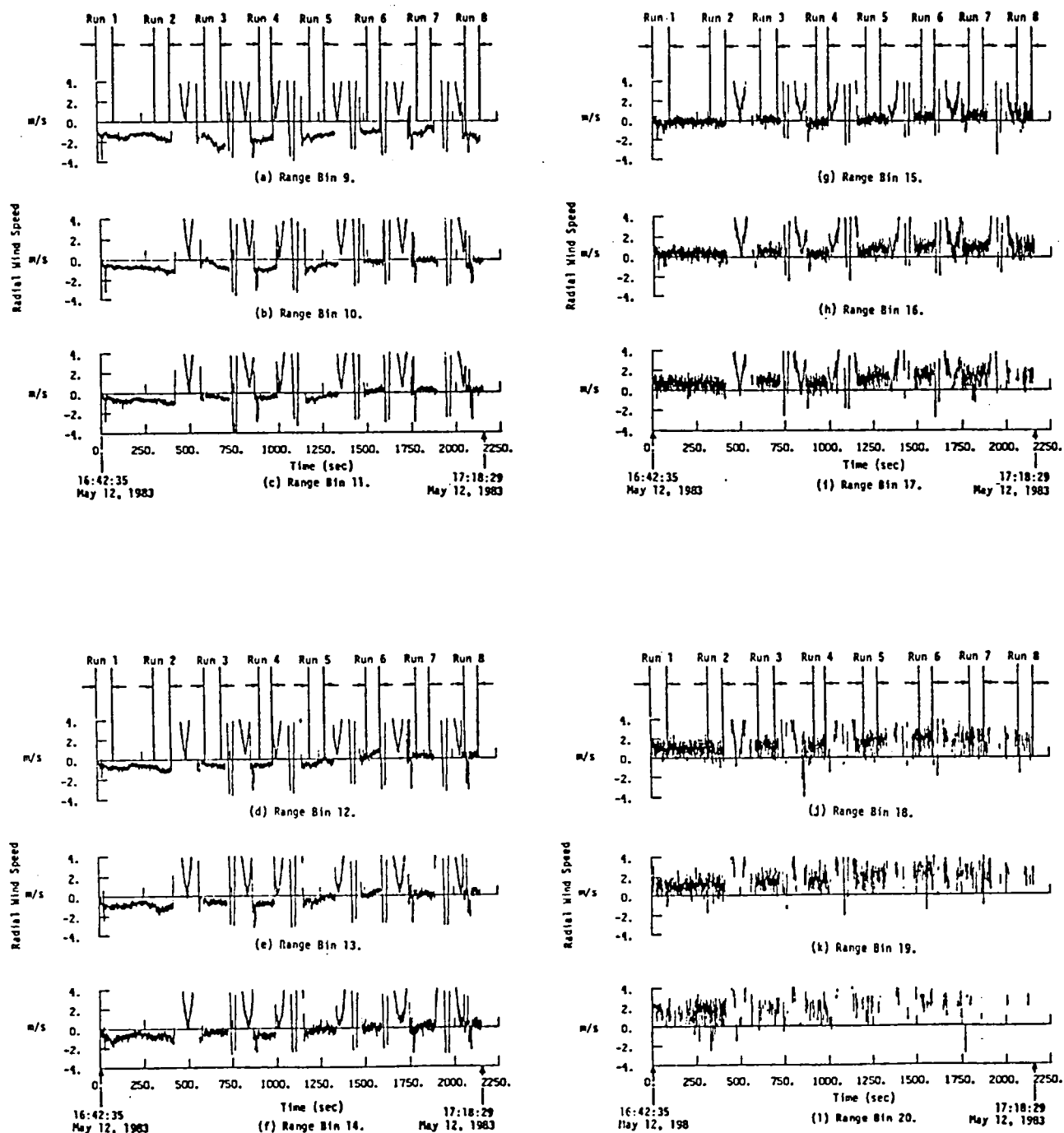

Figure 6. Time histories of radial wind velocity from lidar measurements.

measurements. Although the exact cause of this difference is not known, it is reasonable to assume that due to the unusual drift in the INS the aircraft velocity may be low because of the Schuler oscillation phenomenon.

In general, the trends of the aircraft-measured wind most closely follow the lidar measurements when the assumption of vertical homogeneity is made. This implies that the best agreement is achieved when the aircraft is at the same distance from the lidar even though it may be above or below the lidar beam at that distance. Horizontal homogeneity, of course, implies that the aircraft is making measurements at the same height as the lidar beam for the given range bin, but may be further from, or closer to, the lidar location in horizontal distance. It should be noted that no attempt is made to correct the velocities for convective effects, i.e., translation of the air parcel parallel to the lidar beam, nor for surface terrain contour effects. A terrain correction may help improve the data comparison since the lidar beam passed directly over the top of a mountain, whereas some of the flight paths may have passed to one side or the other. The agreement of the data is believed to be sufficiently good that no terrain correction was attempted.

Computed turbulence intensities for the radial wind speed component from the aircraft measurements and the lidar measurements are also shown in Figure 7. In the figure, the turbulence intensity of the lidar-measured wind is computed from:

$$\sigma_w = \frac{1}{N} \sqrt{\sum_{n=1}^N (W(t) - \bar{W})^2} \quad (1)$$

where \bar{W} is the average wind speed for the period of time the aircraft passes through or parallel to the range bin of interest and $W(t)$ is the fluctuation in wind. The summation is carried out over N time increments of $\Delta t = 0.455$ second which lapses the time interval between the aircraft entering and leaving the range bin. This time interval is used both in computing the aircraft turbulence intensity, illustrated in the figure by the small plus signs, and the lidar turbulence intensity, indicated by the small circles. The interesting result is that the turbulence intensities, although scattered, are intermingled, indicating general agreement between the lidar-measured turbulence intensity and the aircraft-measured values. This is particularly true for the lower range bins.

This result is an important observation. It is apparent that results from the present study contradict this thinking. It is generally thought that the Doppler second moment data will correlate with essentially point measured turbulence intensities obtained from the aircraft. The fluctuations in the radial wind component time history, on the other hand, being values of wind averaged over the spatial

extent of the range bin, are thought to not necessarily correspond to turbulence measured internal to the volume element.

As noted earlier, only three range bin values of spectral width determined turbulence intensities could be extracted from the lidar signal. These values range from 1.26 to 2.51 m/s; almost a factor of ten larger than values measured by the aircraft or computed from the lidar data as described above.

In order to investigate the turbulence measurements further, the turbulent energy spectra were computed. Turbulence spectra was computed for each of the eight flight paths and at each corresponding range bin, assuming vertical homogeneity. The spectrum computed for each range bin for the eight aircraft flights was then segment averaged to provide the spectra illustrated by the small plus signs in Figure 8. Similarly, spectra for a 2-minute time period begin at the time the aircraft enters the range bin, or a region parallel to it, were then computed from the lidar data. Note these data are sampled at approximately two times per second resulting in a Nyquist frequency of approximately 1 Hz. The aircraft data, on the other hand, are sampled at 40 times per second resulting in a Nyquist frequency of 20 Hz. The spectra computed from the lidar data were only five segment averaged. The reason for this is illustrated by inspection of Figure 6. At times, corresponding to some of the later aircraft flights, the radial wind measured by the lidar at the higher elevations or higher numbered range bins (i.e., approximately Range Bins 16 through 21) was extremely intermittent. This is probably due to cloud formation during the later runs. Therefore, although these time histories provide a reasonably valid average or mean wind speed, they do not allow a valid spectrum to be computed. At the lower range bins (i.e., Range Bins 11 through 16), very good agreement with the aircraft data is observed. Note Range Bins 9 and 10 were not used because very few aircraft flights descend to that height.

Although the data do not fall on top of one another because of the different sampling frequencies involved, the spectra do merge together forming a relatively continuous line. This indicated that the distribution of turbulent intensity in the frequency domain is essentially the same for both measurements. The disagreement in spectra at the higher range bins is due to increasing noise or decreasing signal-to-noise ratio, which is clearly apparent in Figure 6.

The very good agreement both in turbulence intensity, and in turbulence spectral properties occurring in the clear-air measurements, leads to the conclusion that computed values of turbulence properties using the time history of the lidar-measured winds provide highly meaningful results. Although further research is required, this suggests that the second moment or spectral width of the Doppler frequency from the lidar may not be necessary in order to compute turbulence properties. If this is true, the time history of the wind speeds measured by the lidar can

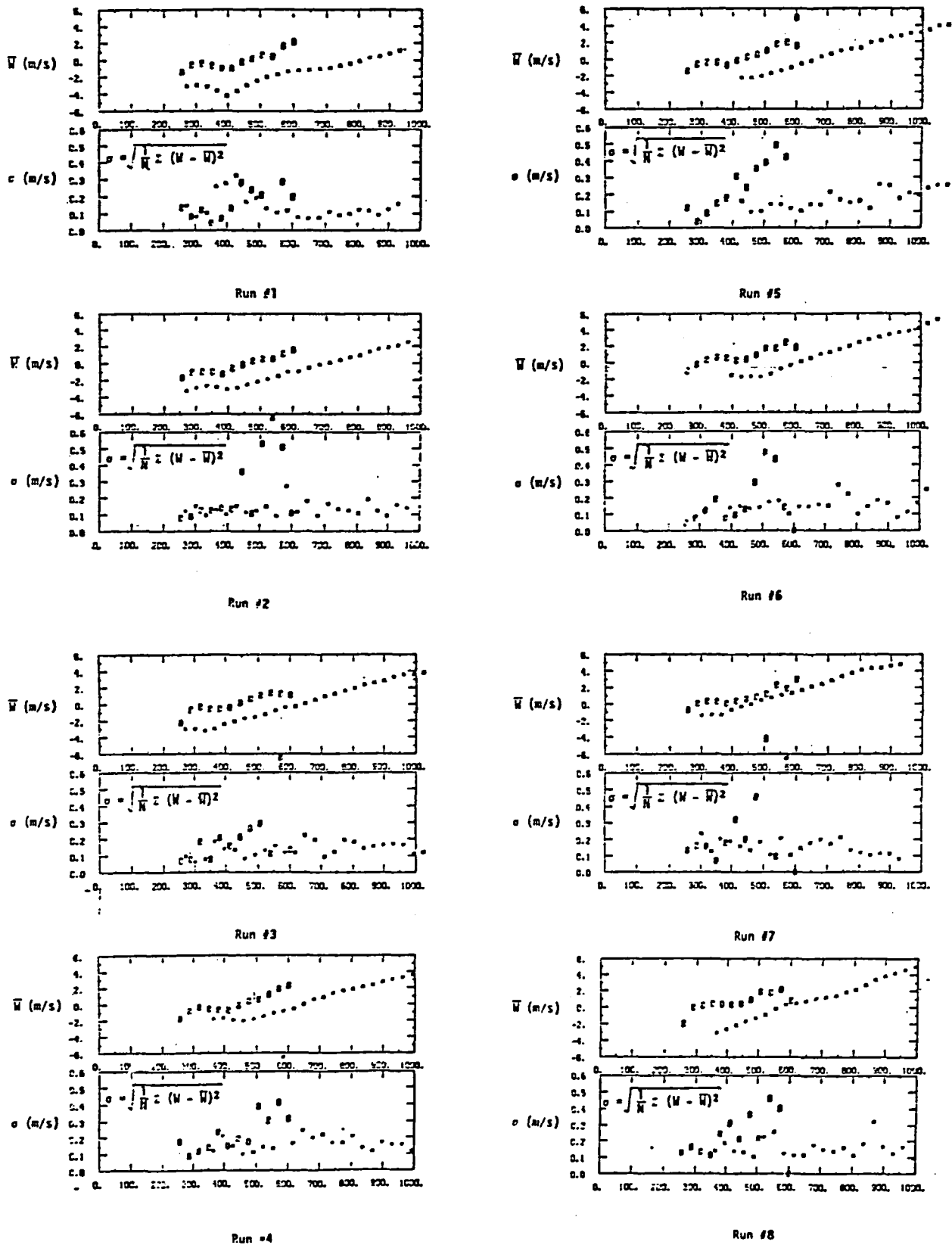

Figure 7. Comparison of lidar-measured winds with aircraft-measured winds and computed turbulence (assumed vertical homogeneity); Aircraft = x, Lidar = o.

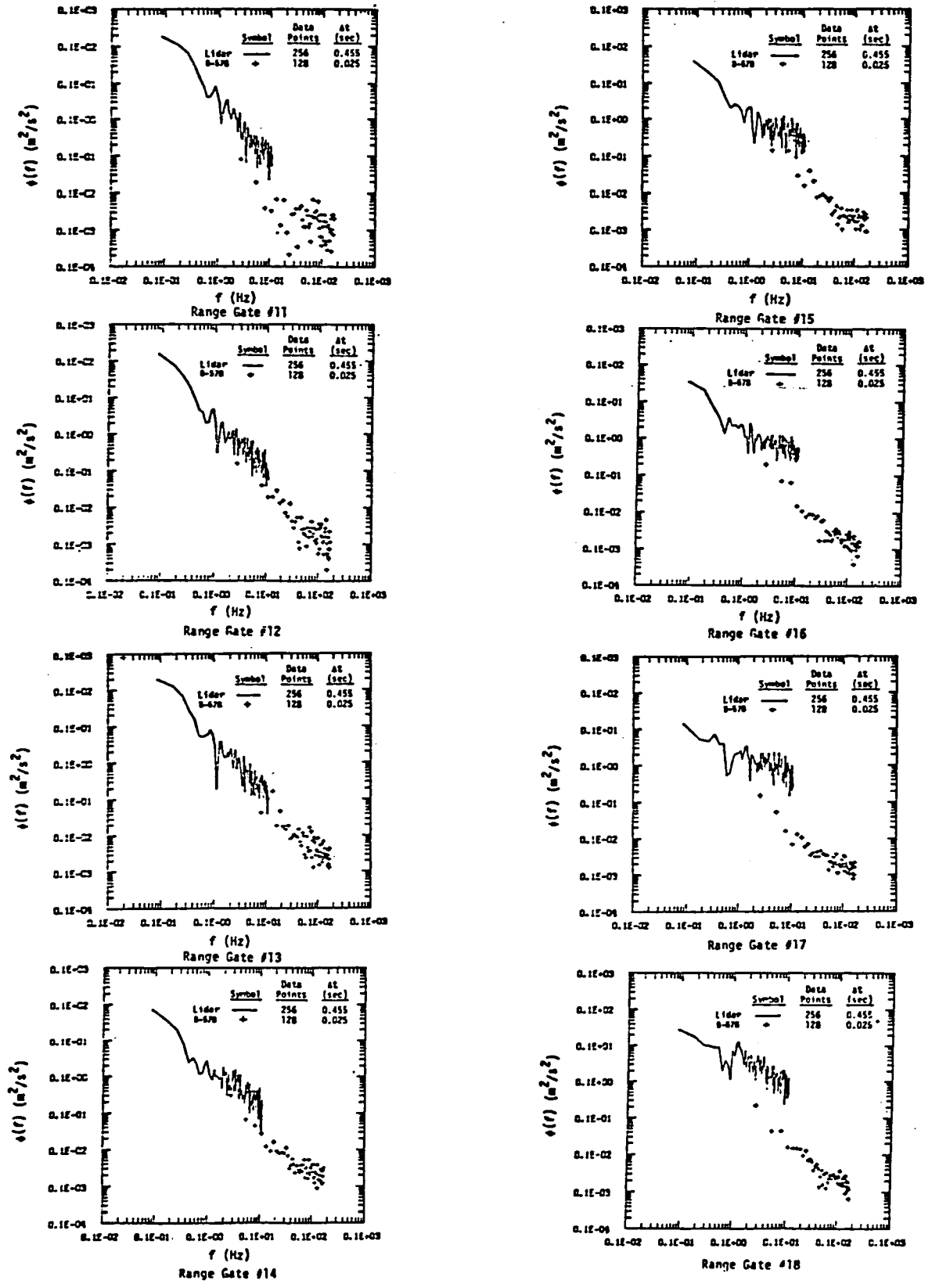

Figure 8. Radial velocity spectra.

simply be analyzed for turbulent statistical properties of interest.

Conclusions

It is concluded that very good agreement between remotely sensed winds using a ground-based Doppler lidar and in situ measurements with an instrumented aircraft is possible. Results show that turbulence intensities computed from time histories measured with the aircraft and time histories of the radial wind measured with lidar can be analyzed statistically to provide turbulence intensities and turbulence spectra which agree well with one another. The results further show that the second moment data, as presently compared with the NASA/MSFC algorithms, do not provide meaningful comparisons with turbulence intensities measured with the aircraft. This disagreement, however, must be investigated further in terms of the accuracy of the second moment data determined by both the lidar hardware and the algorithm for computing the second moment.

References

- Bilbro, J. W. and W. W. Vaughan (1978): "Wind Field Measurement in the Nonprecipitous Regions Surrounding Severe Storms by an Airborne Pulsed Doppler Lidar System," Bulletin of the Am. Met. Soc., 59(9): 1095.
- Campbell, W., D. W. Camp, W. Frost (1983): "An Analysis of Spanwise Gust Gradient Data," Preprints: Ninth Conference on Aerospace and Aeronautical Meteorology, June 6-9, 1983, Omaha, NE, Am. Met. Soc., Boston, MA.
- Frost, W. and K. H. Huang (1983): "Doppler Lidar Signal and Turbulence Study," Final report prepared for NASA Marshall Space Flight Center under Contract NAS8-35185 by FWG Associates, Inc., Tullahoma, TN.
- Frost, W and M. C. Lin (1983): "Statistical Analysis of Turbulence Data from the NASA Marshall Space Flight Center Atmospheric Boundary Layer Tower Array Facility," NASA CR 3737.
- Jeffreys, H. B. and J. W. Bilbro (1975): "Development of a Laser Doppler System for the Detection and Monitoring of Atmospheric Disturbances," NASA TM X-64981.
- Lee, R. W. (1982): "NASA Airborne Doppler Lidar Program: Data Characteristics of 1981 Wind Field Measurements," Technical Report #1, Prepared for NASA/MSFC under Contract NAS8-34768 by Lassen Research, Manton, CA 96059.

LIGHTNING DETECTION AND LOCATING SYSTEMS

Russell L. Hovey
Office of the Federal Coordinator
for Meteorology (DOC/NWS)

Introduction

In September 1983, the Office of Inspector General (OIG), Office of Audits (OA), Denver Regional Office (DRO), and the United States Department of Commerce (DOC), published a management audit report entitled, "Thunderstorm Killers - Flash Floods and Lightning, Need to Improve Severe Weather Forecasting." The purpose of the review was stated to evaluate National Weather Service (NWS) severe weather forecasting and to determine possible improvements in forecasting life-threatening severe weather, especially flash floods and lightning. The report briefly reviewed the historical development of severe storm forecasting, reviews loss-of-life statistics due to severe weather, and concludes that lightning has killed more people from 1940 through 1981 than tornadoes and hurricanes combined. Specific conclusions and recommendations were provided which are directed toward improving the national capability in providing public warnings of flash flood and lightning.

Federal agencies have pointed out that there are several coordinating mechanisms at work regarding the overall lightning issue. They also agree that improved coordination among agencies operating lightning detection systems might be mutually advantageous. As a result of this stimulus and general agreement among concerned agencies, there was a positive response to a request from DOC members of the Interdepartmental Committee for Meteorological Services and Supporting Research (ICMSSR) for preparation of a report on present and planned lightning detection systems by the Office of the Federal Coordinator for Meteorology (OFCM).

A report is being prepared under the guidance of the OFCM for containing information outlining the present and planned lightning detection capability in all agencies and discusses opportunities for data sharing and cooperation.

Agency and Other Programs

Interest in lightning and lightning detection is evident in the programs of the governmental agencies, academia, industry (such as power companies), and the general public as served by TV stations. Each has particular interests and objectives. The following is a brief summary of these interests and programs of government agencies.

Summary of Agency Programs:

- The Western United States and Alaska are essentially covered by an operational lightning detection network operated and maintained by the Department of Interior, Bureau of Land Management (BLM). "Real-time" data are provided to other agencies.
- The Eastern United States has a research network operated by the State University of New York (SUNY) at Albany, New York. It is an expanding network funded by the National Science Foundation (NSF), by SUNY and partially by private industry and other government agencies. Data are made available to government and industry by special arrangement with SUNY.
- The Department of Defense, U. S. Navy (DOD/USN), either has or is planning significant activities covering the Eastern and Central U. S. These facilities are operated at present as local use facilities and are not in a network configuration.
- Other lightning detection facilities exist in the East Central U. S. which are not part of network configurations. Incorporating these facilities into existing or planned networks will require communications (ground or satellite) and data processors.
- Detection facilities are of two basically differing techniques: time of arrival and magnetic field direction finders (DF), and controversy remains concerning the relative capability of each. Thus the facilities are not compatible, but the data from each can be accommodated in a data distribution system which would accept processed data from the different detection networks.
- The SUNY network (currently characterized as an R&D network), if included as a part of a national network, would require some organizational and funding arrangements to accommodate the commitments already made by SUNY and to assure availability of the system as part of an operational network.
- Currently, there are no federal standards within which the existing systems must operate. Use of differing systems raises questions of relative accuracies, false alarm rate, etc. Procedural instructions of standards will most certainly be required in a network configuration.
- There are no well-established arrangements for archiving operational data from existing or planned networks. The Department of Interior (BLM)

has initiated an arrangement and agreement with the other agencies (Department of Agriculture, Forest Service, and possibly others) at its facility in Boise, Idaho.

- In some cases, funding of lightning detection research or operations by agencies is part of larger funded programs and are not identifiable as uniquely funded programs.

Sensor System Descriptions

Several lightning detection sensor designs have been developed in recent years which are the basis for lightning (sferics) detection systems. The three most prevalent of these design approaches are:

1. The magnetic direction finding equipment developed by Krider and now manufactured by Lightning Location and Protection, Inc. (LLP), which utilizes the angle-of-arrival approach;
2. A time-of-arrival (TOA) system developed by Bent and manufactured by Atlantic Scientific Corporation;
3. A satellite-borne lightning imager consisting of a fast lens telescope, a narrow band interference filter, and a focal plane photon detector developed by NASA.

Although systems for the detection and tracking of lightning bolts have been around since the days of Ben Franklin, modern techniques use one of these basic sensor designs.

The physical mechanisms upon which the generation of lightning is based are not universally agreed upon; however, it is generally accepted that lightning is a thermodynamic process within a cloud resulting in a big spark generator. This process sets the stage for cloud-to-ground, cloud-to-cloud, and intracloud discharges.

The ground-based lightning detection systems now being implemented are designed for the detection of cloud-to-ground discharges. Except for the Ryan Storm Scope, these systems take pains to filter out intra-/intercloud discharges between storm cells.

Cloud-to-ground discharges occur when the cloud potential reaches a level near breakdown and a leader or spark is generated between the cloud and earth. The leader creates an ionized trail which, when it reaches striking distance to Earth, results in the main stroke of approximately 200K amperes from earth to the cloud following the ionized trail left by the leader. Four or five return strokes approximately 10 microseconds in duration occur for each leader within a few milliseconds. These strokes generate an Electromagnetic Pulse (EMP) which radiates radio frequency (RF) energy or noise which is the signal detected by the sensors. Most of the energy is in the Very Low Frequency (VLF) 1 KHz band and is distributed at

decreasing amplitudes up through the Ultra High Frequency (UHF) 10 GHz band.

A similar mechanism occurs for intra-/intercloud discharges between cells within a cloud and for cloud-to-cloud discharges. The EMP intensities of these discharges are a fraction of the cloud-to-ground discharge. Even so, the electromagnetic fields generated by the discharges can induce potentials in power and signal lines which have disastrous effects.

The magnetic direction finding equipment senses the electromagnetic fields of the lightning using two orthogonal magnetic loop antennas and a flat plate electric field antenna. A wide bandwidth (1 MHz) receiver is used to preserve the shape of the pulse. The system is designed to respond only to the waveshape characteristic of the cloud-to-ground flashes. This equipment outputs the angle with respect to north of the observed EMP. The system manufactured by LLP consists of two or more gated, wideband magnetic DF stations that are separated by tens-to-hundreds of kilometers and transmit lightning direction and signal amplitude data to a central position analyzing (PA) computer. When the PA receives two or more simultaneous inputs from the remote DF stations, it computes the location of the lightning source by either triangulation or the DF angle vectors (Figure 1).

The TOA equipment consists basically of two receivers, one to detect the lightning stroke and the other to detect the highly accurate LORAN timing source. The TOA equipment uses a VHF wideband receiver to detect the lightning and the LORAN C 100 KHz receives timing pulses for synchronization. The output of this equipment is the arrival time of a lightning pulse with respect to the LORAN C synchronization pulse. The system locates the source of the EMP by plotting the arrival time of the pulse from two or more receiving stations. As a result, the receiving equipment is quite simple.

Atlantic Scientific Corporation developed a system (LPATS) which uses three or more (usually four) TOA sensor stations all synchronized to the same LORAN C timing source. These stations are connected via dedicated communications circuits to a central analyzer facility which measures the difference in the times of arrival from the geographical dispersed sensors and determines the location of the lightning using hyperbola triangulation (Figure 2). Tests using TOA systems were conducted by the Air Force Wright Aeronautical Laboratories (AFWAL) in 1979, 1980, and 1981.

The Ryan Storm Scope is an airborne, or may be ground-based, lightning detection system which uses the magnetic direction finding crossed loop and sense antenna sensor to detect the range and azimuth of lightning discharges. Azimuth is determined from the ratio of the two crossed loop antenna inputs. Range is determined by measuring the field strength of the lightning discharge with respect

to a constant. The constant is derived from an assumption that the field strength is relatively constant from discharge to discharge and inversely proportional to the square of the range. A CRT readout with memory provides a plan position display of the lightning strikes. There are about 7,000 storm scopes installed and in use as an in-flight weather avoidance and lightning detection system.

The AFWAL tested the system in the summer of 1981. The results of the tests are contained in AFSC Report AFWAL-TR-83-3083. Basically, they concluded that the storm scope shows reasonable accuracy in azimuth and fairly large inaccuracies (+ or - 25 miles) in range.

The Ryan Storm Scope Company has been acquired by the 3M Company. The 3M Company has incorporated several improvements in the Ryan Storm Scope and now markets it as a 3M product.

NASA has developed a lightning imaging system for installation on a GOES-type satellite which will detect and locate lightning over large areas of the earth. The system has not been implemented and is expected to require additional refinement because of the strong background noise produced by sunlight reflection from tops of clouds.

Implementation of any of these systems should consider:

1. Overall agency requirements
2. Communications costs. A high-quality dedicated duplex telephone circuit costs about \$12,000 per year for each PA
3. Detection and tracking of both intra- and intercloud lightning

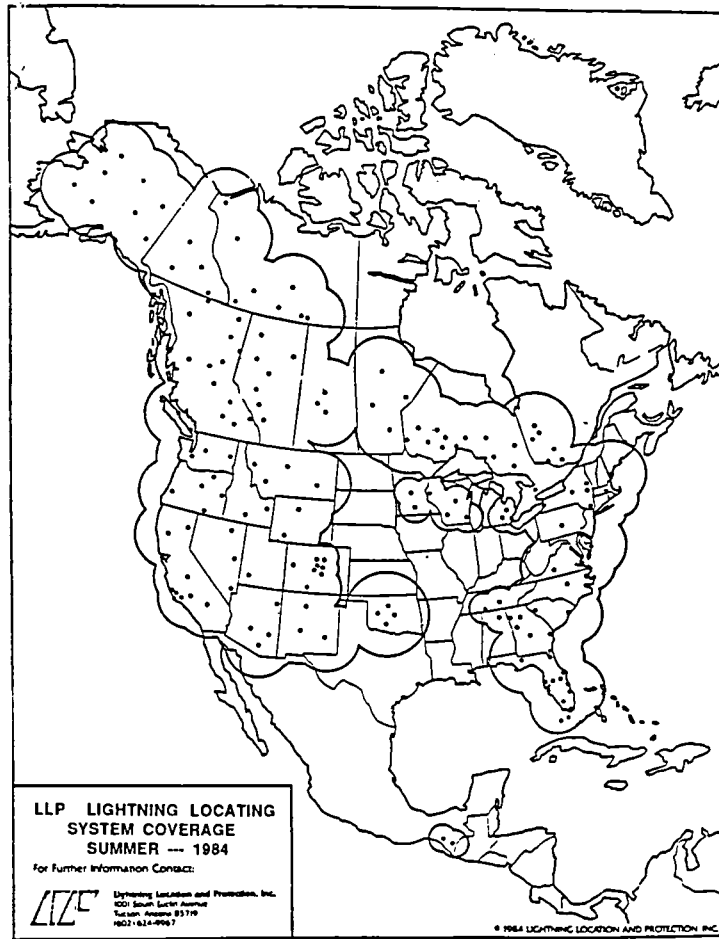

Figure 1. LLP Lightning Locating System Coverage, Summer 1984.

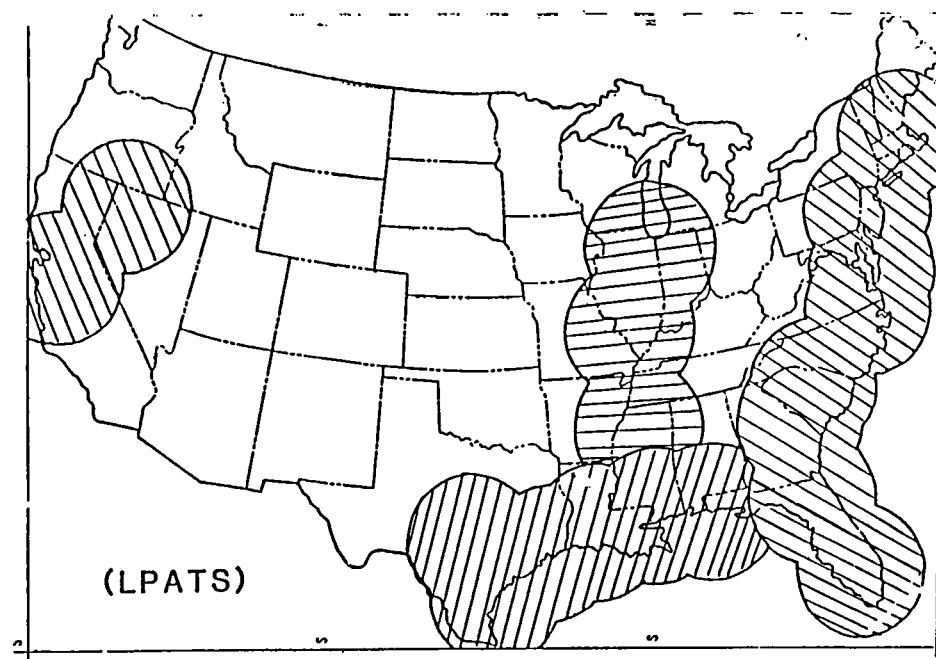

Figure 2. Lightning Position and Tracking System.

NATIONAL PLANS FOR AIRCRAFT ICING AND IMPROVED AIRCRAFT ICING FORECASTS AND ASSOCIATED WARNING SERVICES

Ralph P. Pass
The Analytic Sciences Corporation

Icing has long been recognized as a hazard to aircraft operations. Research on aircraft icing was extensive in the late 40's and early 50's. The advent of turbojet aircraft removed some of the urgency in the investigation of aircraft icing. As a result, research in this area was curtailed.

Recently, new aircraft designs, the emphasis on more fuel efficient operation, the use of composite materials, increased commuter aircraft use and increased rotorcraft use have combined to place greater demands on the government and private industry. Users demand greater flexibility in aircraft use both in civilian and military operations. This includes the use of aircraft in limited icing conditions, better resolution forecasts (spatially and temporally), and the use of rotorcraft in icing environments.

Recently, the United States' leadership in aviation was challenged when the French Puma and SuperPuma helicopters were certified by the FAA for operations in icing conditions. World-wide use of U. S. aircraft requires the understanding of icing environments world-wide and identification of all icing conditions. Current U. S. approval for aircraft operation in icing environments is limited to supercooled clouds and definition of the icing environment is based solely on data collected in the United States.

Recently, the United States has increased its activities related to aircraft icing in numerous fields: ice phobics, revised characterization of icing conditions, instrument development/evaluation, de-ice/anti-ice devices, simulated supercooled clouds, computer simulation and flight tests. These activities are carried out by several agencies. Obviously missing in the list of activities are those related to forecasting.

The Office of the Federal Coordinator for Meteorology is currently involved in two efforts currently under way to improve U. S. activities related to aircraft icing: one by the National Aircraft Icing Program Council (and its working group), and the second by the Committee for Aviation Services. The first effort is developing a National Plan on Aircraft Icing, and the second, in developing a plan for Improved Aircraft Icing Forecasts and Associated Warning Services.

The plan on forecast improvement started first and is being integrated into the National Plan. For this reason, the contents of the plans will be consistent and have similar organization. Each plan addresses: needs, current activities, projected activities, gaps, new initiatives, resources and schedule. The intent of the plans is to increase coordination of activities, avoid unnecessary duplication, provide a road map for future activities, and provide milestones for developments.

The National Plan seeks to define activities in the following major areas:

- Standard terminology and definitions related to aircraft icing emphasizing quantification
- Complete characterization of atmospheric icing environments
- Improvements in simulation of in-flight aircraft icing conditions
- Improved computer simulation of aircraft icing
- Evaluation of effects of approval for aircraft operation in limited icing conditions
- Reduced costs for qualification and certification
- Accurate, reliable, low-cost instrumentation for icing indications onboard aircraft
- Detailed forecasts of aircraft icing hazards

The last of these areas is further expanded in the Forecast Plan to include the following areas:

- Quantified forecasts related to aircraft icing
- Forecasts of meteorological values (e.g., Liquid Water Content, temperature)
- Relation of meteorological values to icing hazard (per aircraft)
- Required instrumentation to generate accurate forecasts
- Education of users on new methods, their significance, use and accuracy
- Dissemination of data for forecasts and of forecasts to users

The first step recommended is to validate the current forecast procedures to provide a starting point for future developments. This validation would include the definition of all current forecast procedures, a well documented data set to substantiate the quantitative assessment of current procedures (also useful for evaluation of future developments) and characterization of accuracy and errors.

Efforts on the two plans are finalizing the drafts of the reports in preparation for the publication of the reports.

These two plans will provide an approved structure for future U. S. activities related to aircraft icing. The recommended activities will significantly improve the position of government agencies to perform mandated activities and to enable U. S. manufacturers to be competitive in the world market, both in cost and capabilities. This should assure continued safe operation of the U. S. airspace, expanded operation of aircraft, and aircraft which lead the world in safe and economic operation in icing environments.

OBJECTIVE DETECTION AND FORECASTING OF CAT: A STATUS REPORT

John L. Keller
University of Dayton Research Institute

Accidents involving encounters with clear-air turbulence (CAT) have shown some increase over the last five years. Reasons include reduced staffing of airline meteorology departments, and the decreasing volume of pilot reports (PIREPs) passed through air traffic control (ATC) centers. Hence, CAT has become the largest single cause of weather-related injuries occurring in commercial carriers at cruising altitudes.

A technique for objective operational CAT detection (the SCATR index) has been formulated. Its physical basis ties CAT to total energy dissipation as a response to meso- and synoptic-scale dynamical processes associated with upper-level jet stream/frontal zones. Early case studies using properly analyzed routine RAOB rawinsonde sounding data (provided by the PROFS/Central Weather Processor (CWP) group) have shown promise.

Introduction

Clear-air turbulence (CAT) continues to be a significant problem for commercial flight operations above about 500 mb. Upper-level SIGWXs (significant weather advisories), which rely heavily on PIREPs, seem to be the only reliable means of monitoring CAT. The currently available SIGWX forecasts are highly subjective and generally considered unreliable. A technique has been developed for CAT detection which is objective and is based on sound physical principles: the Specific CAT Risk (SCATR) index formulation [Keller, 1984, 1985].

The SCATR index technique, originally formulated by Roach (1970), uses objectively analyzed grid point data from RAOBs consisting of horizontal wind components, temperature and heights to diagnostically calculate a quantitative measure of the total energy dissipation rate due to CAT which results from meso- and synoptic-scale deformation processes. That RAOB data can be used to resolve mesoscale features has been suggested by Keller (1981) and Kennedy and Shapiro (1980). Further studies into the role of CAT as a diabatic heat source, done as part of the previous research effort for NASA and PROFS into the physical basis of the SCATR formulation, seem to show that both the structure and intensity of CAT as predicted by the SCATR formulation are consistent with observational measurements of CAT by experimental aircraft (e.g., Shapiro 1976; Kennedy and Shapiro 1975, 1980).

Background

The basis of this technique is a deterministic formulation for calculating the rate of total energy dissipation in the free atmosphere. This formulation is an extension of that originally published by Roach (1970). The formulation has been extended in part by applying it to an idealized model based on aircraft measurements of turbulence made subsequent to Roach's work (Kennedy and Shapiro, 1975, 1980). An analysis of this case has shown that the SCATR index formulation predicts CAT of an intensity and structure consistent with turbulence observed by experimental aircraft in frontal shear zones in this study.

In this formulation, CAT is viewed as a manifestation of internal, frictional dissipation of total energy within a volume of air of unit area and of potential temperature thickness, $\Delta\Theta$. The rate of total energy dissipation, vertically integrated through $\Delta\Theta$ can be shown (Roach, 1970) to be

$$\bar{E}_L = \begin{cases} \frac{(\Delta V)^2}{24} \Phi_L, \Phi_L > 0 \\ 0, \Phi_L \leq 0 \end{cases}$$

where in isentropic coordinates

$$\Phi = \left(-2 \left| \frac{\partial \vec{V}}{\partial \theta} \right|^2 \cdot \left[\frac{\partial \vec{V}}{\partial \theta} \cdot \left(\frac{\partial \vec{V}}{\partial \theta} \cdot \nabla \right) \vec{V} + \frac{c_p}{\theta} \frac{\partial \vec{V}}{\partial \theta} \cdot \nabla T \right] + \nabla \cdot \vec{V} \right)$$

ΔV is the magnitude of the horizontal vector wind difference through $\Delta\Theta$, and

$$\left(\right)_L = \frac{1}{\Delta\Theta} \int_{-\Delta\Theta/2}^{\Delta\Theta/2} \left(\right) d\Theta$$

The mathematical development of this formulation is given in isentropic coordinates which yield somewhat cleaner derivations than the pressure coordinates used by Roach in his development (Keller, 1986). The use of isentropic coordinates has other benefits, in particular with respect to resolving internal fronts.

The quantity, Φ_L , represents the grid scale forcing by larger-scale dynamical processes which are attempting to change the local gradient Richardson number,

$$Ri_L = \left(\frac{g}{\theta_o} \right) \frac{\Delta\Theta\Delta Z}{(\Delta V)^2}$$

within a given layer. Roach's fundamental assumption is that turbulence occurs within the layer as a response to these forces when they are acting to decrease Ri_L too rapidly within the layer. The role of turbulence is to work against these forces in an attempt to maintain Ri_L at a small but nearly constant value. At least one observational study (e.g., Kennedy and Shapiro, 1975) has shown that the rate of energy dissipation is nearly equal to the rate at which the larger-scale deformation field, associated with the three-dimensional meso- and synoptic-scale dynamics of the jet stream/frontal layers, is acting to increase the vertical shear within the layer. Since Ri_L is highly dependent on the vertical shear, this suggests that the basic assumption is not unreasonable. No such relationship is assumed to be relevant to layers where these large-scale processes are attempting to increase Ri_L .

Some Results

The tasks under the effort with the PROFS/CWP application have included verification of the formulation and resulting algorithms being used, calculation of a specific CAT risk (SCATR) index, and validation of expected regions of CAT against PIREPs. In those cases studied thus far the performance of the SCATR index, calculated using objectively analyzed rawinsonde data, has been quite encouraging. Since the formulation being applied is sensitive to the input data, it is anticipated that the performance of this index will improve as both data systems and analysis techniques evolve at PROFS.

Estimates of turbulent energy dissipation rates have been calculated for several cases of documented CAT. The grid data used for this purpose were provided by objective analysis of standard raw RAOBs on isentropic surfaces. The values of energy dissipation rates were consistent with what is to be expected from moderate-to-severe turbulence, taking into account some known minor limitations in the current analysis and computer algorithms.

Figure 1 shows a cluster of reported encounters (the locations were provided by C. Knable, United Airlines personal communication) which occurred between 0200Z and 0400Z, 29 October 1983, over central Colorado between about 28,000 and 32,000 feet. Also shown are isolines of the SCATR index calculated using analyzed 0000Z, 29 October 1983, data for the 356 K isentropic surface or approximately 32,000 feet near the area of the encounters. The locations of the horizontal grid points are shown by the little '+'s.

Figure 2 shows the SCATR index field for the 352 K (or 35,000 feet) surface for 0000Z, 28 November 1984, over the Wisconsin/Illinois area. Although their exact coordinates are not shown, numerous reports of moderate to severe CAT were reported over southern Wisconsin and northern Illinois within several hours

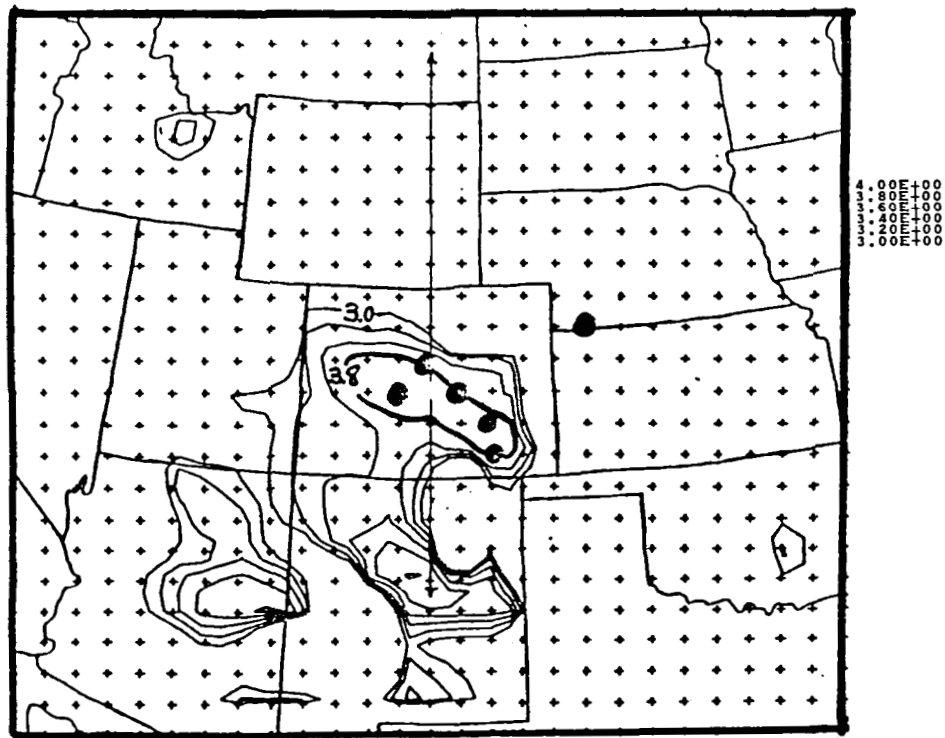

Figure 1. Cluster of CAT Encounters over Central Colorado between 28,000 ft. and 32,000 ft., 29 October 1983.

$$(\text{ = Log } \bar{E}_L + 7)$$

352K (~ 35,000 ft.)

$$\bar{E}_L = \frac{(\Delta v)^2}{24} \phi_L$$

Calculated using RW data analyzed by NOAA/ERL/PROFS
Central Weather Processor Project.

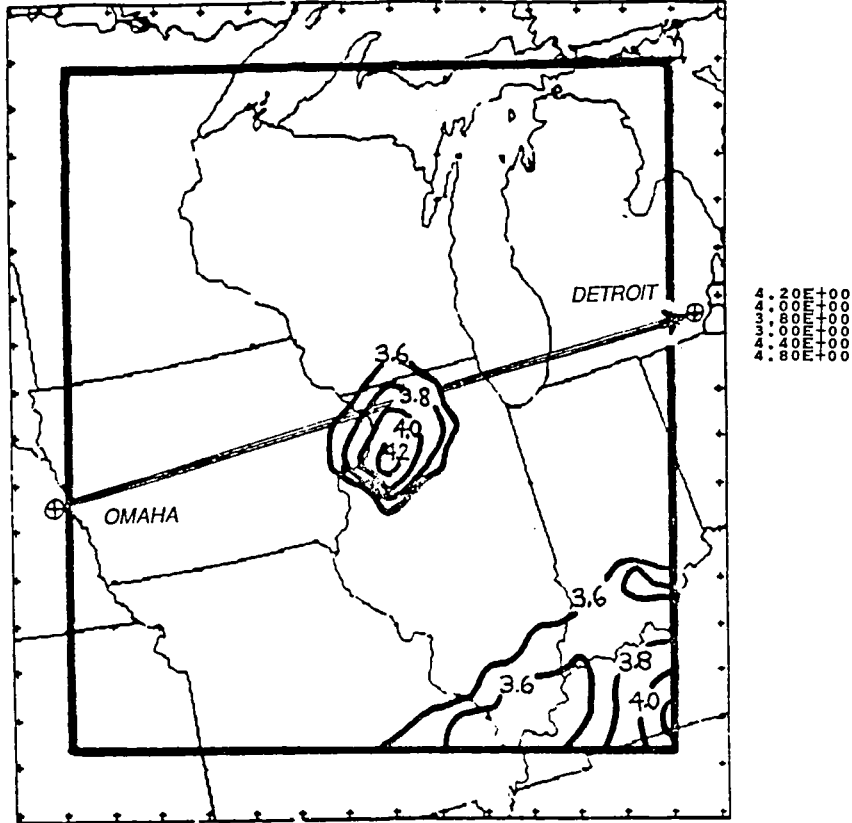

Figure 2. SCATR Index Field for 35,000 ft. on 28 November 1984, over Wisconsin/Illinois Area.

of this analysis time (J. Pappas, Western Airlines personal communication). A line is shown running diagonally from Omaha, Nebraska, to Detroit, Michigan. This is supposed to represent a hypothetical flight path between these two cities. Figure 3 shows the vertical cross section corresponding to this hypothetical flight path. This is a good illustration of the potential use of such an index. Provided with such a picture, an ATC meteorologist could suggest that flights along this path might use flight level 280 or 300 to minimize the possibility of encountering CAT.

Summary

The PROFS/CWP project has made a good start in applying a prototype algorithm of the SCATR index formulation into its software system. Several cases of documented commercial aircraft encounters with severe CAT have been examined. Consistent with its apparently sound physical basis, the performance of the SCATR index in these cases has been quite encouraging. Because of the important role of mesoscale deformation processes in CAT formation, the performance of the SCATR index should improve as the data base “enhancements”, which increase the resolution in both space and time, are brought into the objective analyses. The SCATR index should also have applications in the forecasting of CAT potential using forecasted variables as input or by actually being built into the code of a short-term (3-12 hours) forecasting model.

While a great deal of progress has been made during the first nine months of the effort to provide a viable, objective CAT forecasting tool, considerable work remains before the SCATR index is ready to be used operationally in the ATC environment. At this time, all PIREPs of CAT are being archived along with RAOB data at PROFS/CWP in order to perform a statistical validation of the performance of the prototype SCATR index software system. Other tasks necessary in the development of the SCATR index technique to meet operational needs are planned; they include:

- Develop improved algorithm for optimum utilization of isentropically analyzed grid point data.
- Investigate forecasting applications of the SCATR formulation: CAT forecasting as well as its use in parameterizing short-term time dependent forecast models for CAT effects.
- Begin developing parameterizations for terrain (mountain wave) and organized convective systems for their role in exciting atmospheric gravity waves; thus increasing CAT intensity.
- Evaluate the performance of the SCATR index for effect of data “enhancements” once they become operational.

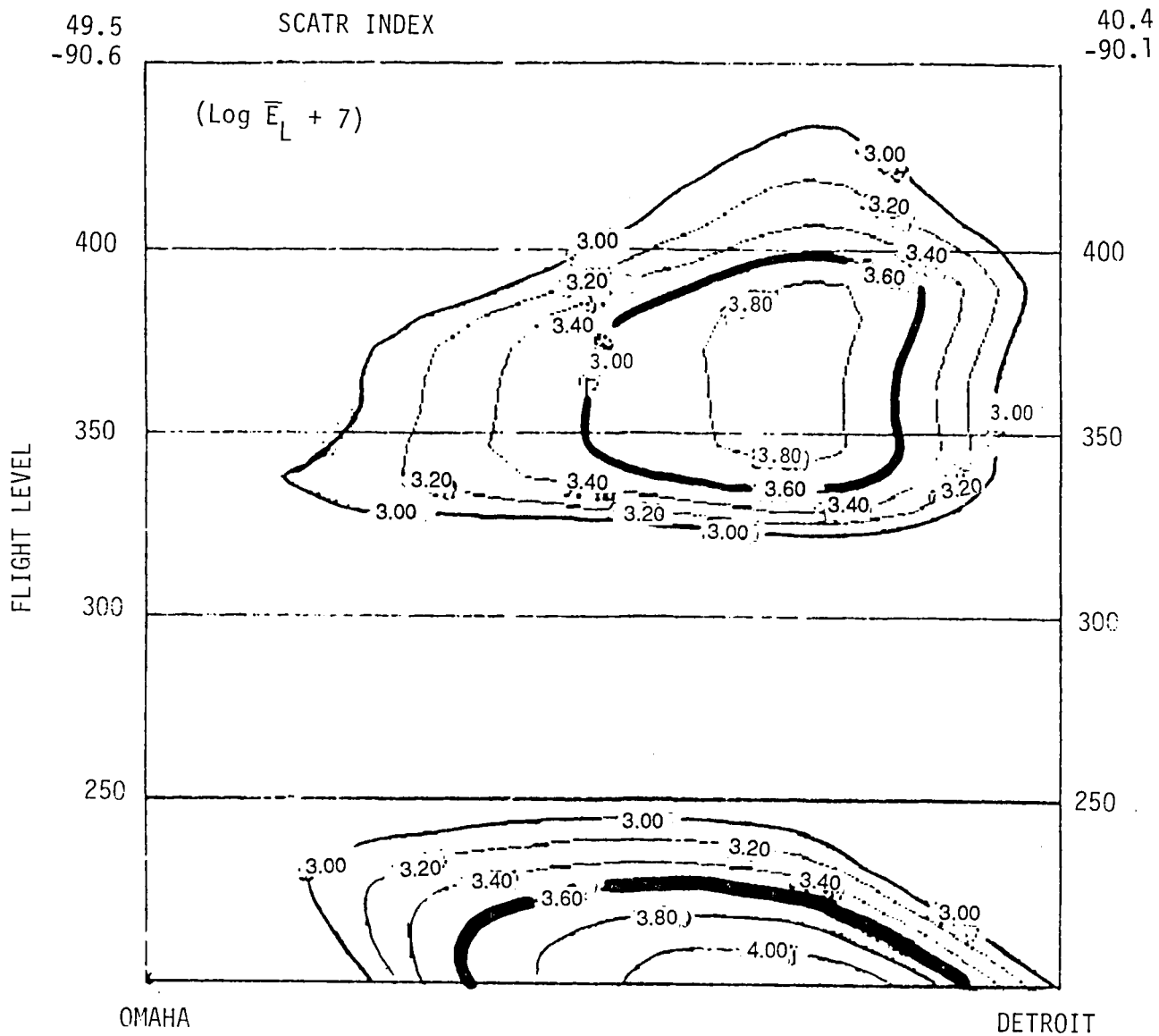

Figure 3. Vertical Cross-section Corresponding to a Hypothetical Flight Path between Omaha and Detroit.

- Compare residual and “direct” total energy dissipation within individual parcels. A statistical analysis will be used to correlate these two independent values. It is hoped that these calculations can be performed using data obtained during the GALE field study.

References

- Keller, J. L., 1981: Prediction and Monitoring of Clear-air Turbulence: An Evaluation of the Applicability of the Rawinsonde System, Journal of Applied Meteorology, 20, 686-692.
- Keller, J. L., 1984: Performance of a Quantitative Jet Stream Turbulence Forecasting Technique: The Specific CAT Risk (SCATR) Index, AIAA Paper 84-0271, Reno, NV.
- Keller, J. L., 1985: Clear-Air Turbulence Forecasting: Towards a Union of Art and Science, AIAA Paper 85-0014, Reno, NV, 7pp.
- Keller, J. L., 1986: The Physical and Empirical Basics for a Specific Clear-Air Turbulence Risk Index, NASA CR-3921, 39pp.
- Kennedy, P. J. and M. A. Shapiro, 1975: The Energy Budget in a Clear-Air Turbulence Zone as Observed by Aircraft, Mon. Wea. Rev., 103, 650-654.
- Kennedy, P. J. and M. A. Shapiro, 1980: Further Encounters With Clear-Air Turbulence in Research Aircraft, J. Atmos. Sci., 37, 986-993.
- Roach, W. T., 1970: On the Influence of Synoptic Development on the Production of High-Level Turbulence, Quart. J. Roy. Met. Soc., 96, 413, 429.
- Shapiro, M. A., 1976: The Role of Turbulent Heat Flux in the Generation of Potential Vorticity in the Vicinity of Upper-Level Jet Stream Systems, Mon. Wea. Rev., 104, 892-906.

COMPARATIVE VERIFICATION BETWEEN GEM AND OFFICIAL AVIATION TERMINAL FORECASTS

Robert G. Miller
National Weather Service
Techniques Development Laboratory

I will give a status report of the effort and some plans we have for the future for the Generalized Exponential Markov Model (GEM), a new statistical forecasting procedure.

GEM uses the local standard airways observation (SAO) to predict hour-by-hour the following elements: temperature; pressure; dew point depression; first and second cloud-layer height and amount; ceiling; total cloud amount; visibility; wind; and present weather conditions such as fog, haze, rain, snow, freezing rain, thunderstorms and their quantitative amounts. In other words, we forecast all of the elements which are in the SAO. To forecast, we use those same elements as predictors, one hour prior to the time of forecast. We collected 4 million SAOs from 41 stations around the country. We developed regression equations that enabled us to predict the probability of each category of these elements, and there were 228 predictors. Each equation had 228 coefficients, and there were 228 equations. The procedure took the one-hour forecasted probabilities and integrated them into the system to project out to the second hour, the third hour, and so forth, until it eventually settled down to climatology.

We have shown that GEM is superior to persistence at all projections for all elements in a large independent sample. By saying this, I imply that we forecast changes and are most frequently successful at hitting them. It has also been demonstrated that GEM performs better than MOS, the procedure that utilizes the LFM dynamical model inside six hours when the operational delays due to model computer run-time are considered. Recently we have finished a comparative study against the predominant conditions of the official National Weather Service terminal aviation forecast (FT). It performs better inside three hours than the FT; however, at three hours and beyond, the FT is better.

Presently we are involved through an interagency agreement with the FAA in an effort to produce a minute-by-minute GEM forecasting system utilizing the Automated Weather Observation System (AWOS). We have currently processed 400,000 AWOS observations in developing an AWOS GEM. Figure 1 shows the weather elements as observed once per minute by equipment similar to the FAA's AWOS.

- Lowest cloud hit
- Second cloud hit
- Third cloud hit
- Fourth cloud hit
- Visibility
- Station pressure
- Temperature
- Dew point temperature
- Wind speed
- Wind direction
- Precipitation amount in one minute
- Precipitation occurrence
- Frozen precipitation occurrence (when successfully measured)
- Date of the observation (month, day, hour and minute)

Figure 1. Data began to be collected at the National Weather Service's Techniques Development and Test Branch location at Sterling, Virginia, in April 1984.

As mentioned earlier, there were 228 predictors for the hourly GEM forecast. Table 1 shows from where the 228 came. Each element was categorized on the average of around 10 categories per element producing 228. In the case of the AWOS, there are 88 variables used as predictors for forecast.

Plans for the future include the following:

- To complete the AWOS-GEM, to produce forecasts on demand utilizing a microcomputer, and to verify these forecasts on independent observation data. (The intent was to begin this on light forecasting in June 1985; at the end of April, one-year's data was accumulated, amounting to nearly 500,000 observations).
- To continue investigating the inclusion of nonlinear predictive information found to be contained in "Boolean" combinations of the raw AWOS elements. (Each of the 88 elements shown in Table 1 are binary variables, and there is a great opportunity to create "Boolean" combinations out of the data collected. Just recently we have discovered that there is a great deal of information here that has yet been untapped.)
- To evaluate the hour-by-hour GEM at the FAA's Flow Control Center with the help of Ray Stralka, NWS.
- To create an ASOS-GEM using the data which Steve Short set out in his paper on Observing Weather during the Overview Presentations section of this workshop.

Table 1. Predictor and predictand categories which specify the dummy variables used in GEM. Shown under the index column are the left-out categories not included because of redundancy.

<u>Number</u>	<u>Weather Element</u>	<u>Category</u>	<u>Index</u>
1	(Always unity)		1
2	Lowest cloud hit (00')	0-1	2
3		2-4	3
4		5-9	4
5		10-29	5
6		30-60	6
7		61-UNL	Left out
8	Second cloud hit (00')	0-1	7
9		2-4	8
10		5-9	9
11		10-29	10
12		30-60	11
13		61-UNL	Left out
14	Third cloud hit (00')	0-1	12
15		2-4	13
16		5-9	14
17		10-29	15
18		30-60	16
19		61-UNL	Left out
20	Fourth cloud hit (00')	0-1	17
21		2-4	18
22		5-9	19
23		10-29	20
24		30-60	21
25		61-UNL	Left out
26	Visibility (<i>miles</i>)	0-31/64	22
27		1/2-63/64	23
28		1-2 63/64	24
29		3-4 64/64	25
30		5-6 63/64	26
31		7-100	Left out
32	Station pressure (<i>inches of Eg</i>)	0-29.235	27
33		29.236-29.530	28
34		29.531-29.677	29

Table 1. (Continued)

<u>Number</u>	<u>Weather Element</u>	<u>Category</u>	<u>Index</u>
35		29.678-29.825	30
36		29.826-29.973	31
37		29.974-30.120	32
38		30.121-30.268	33
39		30.269-30.563	34
40		30.564-35.000	Left out
41	Temperature ($^{\circ}F$)	-30-4	35
42		5-14	36
43		15-24	37
44		25-34	38
45		35-39	39
46		40-44	40
47		45-49	41
48		50-54	42
49		55-59	43
50		60-64	44
51		65-74	45
52		75-84	46
53		85-94	47
54		95-110	Left out
55	Dew point depression ($^{\circ}F$)	0-1	48
56		2-7	49
57		8-15	50
58		16-25	51
59		26-99	Left out
60	Wind Speed (<i>kn</i>)	0-1	52
61		2-9	53
62		10-19	54
63		20-29	55
64		30-99	Left out
65	Wind direction (<i>deg</i>)	00-44	56
66		45-89	57
67		90-134	58
68		135-179	59

Table 1. (Concluded)

<u>Number</u>	<u>Weather Element</u>	<u>Category</u>	<u>Index</u>
69		180-224	60
70		225-269	61
71		270-314	62
72		315-359	Left out
73	Precipitation amount (<i>inches</i>)	.002-.100	63
74		.001-.0019	64
75		.000-.0009	Left out
76	Precipitation occurrence (<i>Y or N</i>)	Yes	65
77		No	Left out
78	Frozen precipitation (<i>Y or N</i>) (when successfully measured)	Yes	66
79		No	Left out
80	Month	January	67
81		February	68
82		March	69
83		April	70
84		May	71
85		June	72
86		July	73
87		August	74
88		September	75
89		October	76
90		November	77
91		December	Left out
92	Hour (<i>LST</i>)	00-01	78
93		02-03	79
94		04-05	80
95		06-07	81
96		08-09	82
97		10-11	83
98		12-13	84
99		14-15	85
100		16-17	86
101		18-19	87
102		20-21	88
103		22-23	Left out

COMPUTER AND MODEL CHANGES AT NMC

Charles H. Sprinkle
Aviation Services Branch
National Weather Service

As my colleague, Colin Flood, has noted in his report, Bracknell has had the availability of the Cyber-205 for about two years. Although the Cyber-205 has been in use at NASA and a few other agencies in the U. S. meteorological community, the meteorological authority of the U. S. did not have a Cyber-205 available to it until last year when the National Weather Service (NWS) began installation of it (Figure 1). The Cyber-205 has now been installed and we are currently in the process of transferring guidance over to the new computer. Prior to the installation of the Cyber-205, the IBM 360/195 was in use and the limited fine mesh (LFM) running time was 20 minutes. The LFM on the Cyber-205 runs out to 48 hours and takes 75 seconds to run. The Cyber-205 is a great "number cruncher," but we have to off-load from the Cyber-205 onto other computers for output so there is a slowdown as the larger numbers are transferred back to the postprocessing computer. Figure 2 shows the current operational cycle starting with an early run, a regional run (which is the LFM model at the present time), and the global run (which is the global spectral model currently running). At 09:30 hours after data time, the Global Data Assimilation System (GDAS) produces the "first guess" for the next run. NWS is currently trying to improve its efficiency in order to get fast, accurate data to pilots and others in need of the information.

NWS is currently examining the possibilities of inputting a physics package to the global spectral model; but it takes a longer running time on the computer to produce with the physics input, and the aviation users cannot afford to wait any longer for the output products to be made available. The improved physics has shown in evaluations that there are improvements noted at three days and beyond; but the improved physics has very little impact on the 0-48-hour range, and that is the range in which aviation is most interested. The global model currently serves aviation interests, as well as all other users. We have not been as successful as Bracknell in breaking out an "aviation only" package versus extended range.

The nested grid model came on-line in the Summer of 1985 and we then had improved resolution. It is expected that it will improve our precipitation guidance. Our target was to implement that early in 1985.

Figure 3 shows the current model structure, and on the extreme left it shows the current global spectral model, which is a 12-layer model. The middle column shows the 7-layer LFM, and the column on the extreme right shows the 16-layer nested grid model, which we are hoping to implement early in 1985. Some other possible

- CYBER-205 INSTALLED 1984
 - TRANSFERRING GUIDANCE TO NEW COMPUTER
 - LFM RUNNING TIME ON IBM 360/195 WAS 20 MINUTES
 - LRM OUT TO 48 HOURS
 - TAKES 75 SECONDS TO RUN LFM ON CYBER-205
- STRUCTURE OF CURRENT NMC OPERATIONAL PREDICTION MODELS
- IMPROVED PHYSICS PACKAGE BEING ADDED TO GLOBAL SPECTRAL MODEL
 - WILL INCREASE RUNNING TIME BY ABOUT AN HOUR
 - AVIATION USERS CANNOT WAIT
 - IMPROVEMENTS NOTED AT 3 DAYS AND BEYOND
 - LITTLE/NO IMPROVEMENT THROUGH 48-72 HOURS OF FORECAST
- GLOBAL MODEL CURRENTLY SERVES AVIATION AND ALL USERS INCLUDING EXTENDED RANGE
- GLOBAL DATA ASSIMILATION SYSTEM (GDAS) PROVIDES "FIRST GUESS" FOR NEXT RUN
- NESTED GRID MODEL (NGM)
 - WILL IMPROVE PRECIPITATION GUIDANCE
 - TARGETED TO BE IMPLEMENTED BY LATE MARCH/EARLY APRIL IS HEMISPHERIC
- VERTICAL STRUCTURE OF THE NMC OPERATIONAL PREDICTION MODELS
- OTHER POSSIBLE CHANGES:
 - EXPAND LFM TO HEMISPHERIC
 - AVIATION MODEL
- HEMISPHERIC LFM
 - WOULD REMAIN 7-LAYER
 - AVIATION GUIDANCE WOULD BE AVAILABLE AT APPROXIMATELY 2 + 30
- AVIATION MODEL
 - WOULD BE PRESENT SPECTRAL WITH THESE CHANGES:
 - IMPROVED TOPOGRAPHY (MOUNTAINS)
 - INCREASE VERTICAL RESOLUTION
 - 18 LAYERS CONCENTRATED AROUND 300-100 MB LAYER
 - WILL RUN JUST ABOUT THE SAME TIME
 - COULD BE IMPLEMENTED BY SUMMER 1985
- MODEL OUTPUTS TO BE EVALUATED FOR QUALITY OF FORECASTS AND TIMELINESS

Figure 1. NOAA/NWS National Meteorological Center Computer/Model Changes.

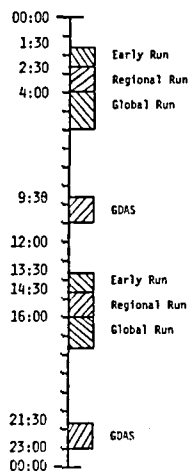

Figure 2. Structure of Current NMC Operational Prediction Models.

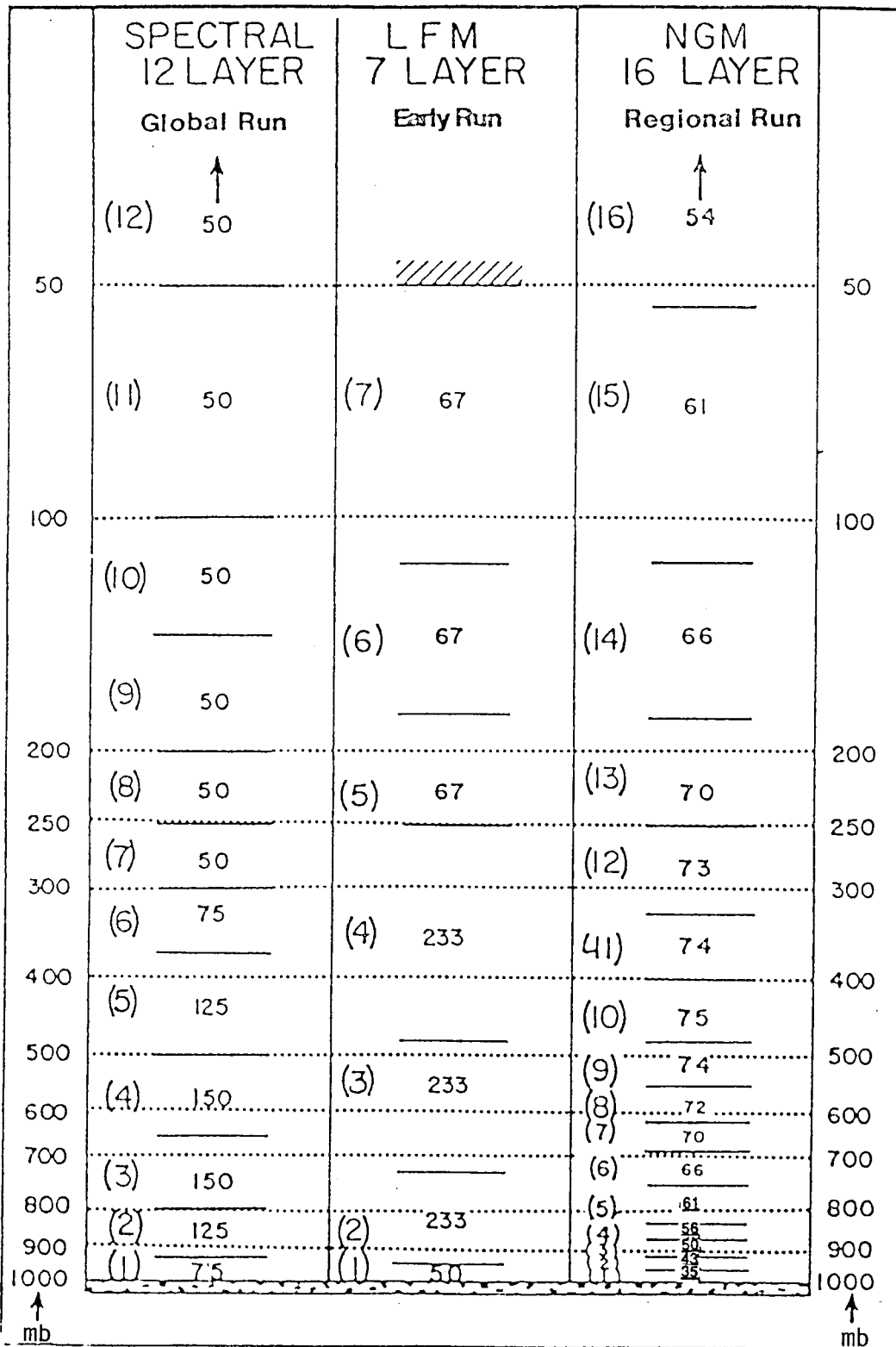

Figure 3. Vertical Structure of the NMC Operational Prediction Models.

changes are to expand the LFM to a hemispheric model in order to output earlier winds and temperatures aloft. We also intend to develop a separate aviation model which would be generally for aviation only. The hemispheric LFM would remain a 7-layer model and the aviation guidance which would be produced from it would be available at approximately 2 + 30 from the data time. Therefore, some indications would be available for winds and temperatures aloft much earlier; however, a much earlier data cutoff time would give us the eastern section of the Pacific, and a good part of the North Atlantic covered, but very little data could be produced for the western section of the Pacific Ocean and it would be based generally on the "guess" generated by the previous run.

The aviation model would be as the current spectral model is now with a few changes. We would input improved topography and increase the vertical resolution. We are planning to increase the "aviation model" to an 18-layer model concentrated in the layer between 100-300 mb. This is the area which would be concentrated around the jets, and we would hope to have a much better resolution definition of the jet stream. The computer running time would be about the same, and the "aviation only" model could be implemented as early as the Summer of 1985. The model outputs would have to be evaluated according to the tests being run at NMC to make sure there is an improvement in the various models.

Figure 4 is an example of the proposed model. The early run would be an LFM around 1 + 30. We have trouble eliminating the LFM run because all of the multiple output statistics (MOS) are based upon the LFM. Therefore, we will have to use the LFM until a data base is gathered to make it possible to run MOS from the nested grid model. The regional run displayed in Figure 4 would be the nested grid model; then the new 18-layer aviation run is depicted with a cutoff time of about 3 + 45. We would hope to improve the time by about one hour for availability of winds and temperatures aloft. At approximately H + 8 hours comes the GDAS. This would be the new global model with the improved physics, and would be the model showing the concentration on days 3-10. The current winds and temperatures aloft are being produced from the LFM model (currently referred to as the FD winds which FSS's see displayed and most pilots use), and the global spectral model which produces what is currently referred to as the ADF winds. They are global in nature (northern and southern hemisphere) and are generated for computer-to-computer use with airlines, as well as the 17 processors of the digital data.

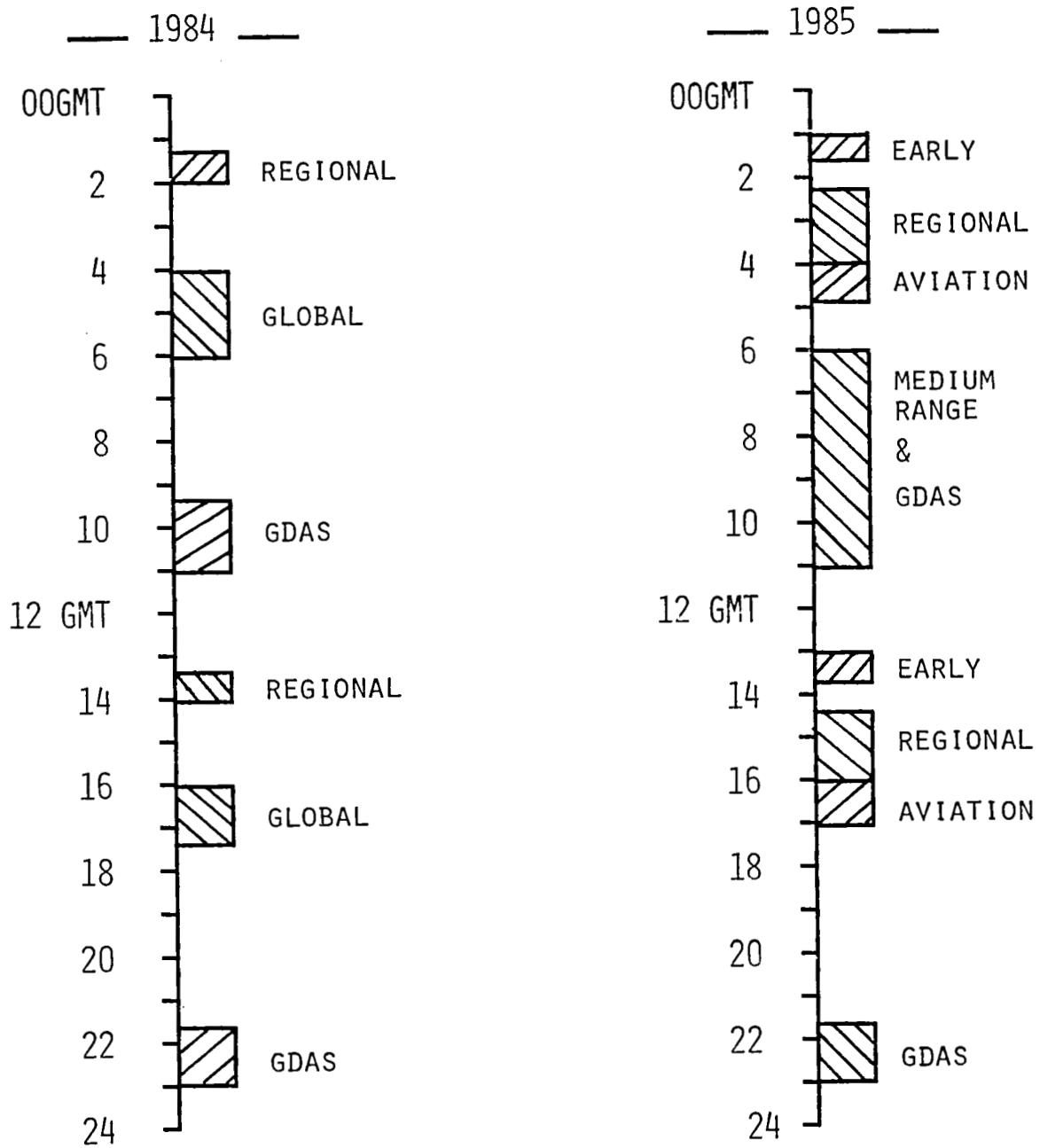

Figure 4. Class VI Computer Numerical Guidance Schedule.

DENVER ARTCC EVALUATION OF PROFS MESOSCALE WEATHER PRODUCTS

John W. Hinkelman
NCAR/NOAA/PROFS

The Denver Air Traffic Control Center has had a Prototype Regional Observation and Forecast System (PROFS) display system since the Spring of 1982. At the request of the Chief of the Denver Center, I will give an updated presentation of the evaluation the Center has made of the PROFS products. A full PROFS workstation capability was installed at the Denver Center in June 1984, and information concerning this can also be obtained through PROFS.

A PROFS display capability was requested by the Denver Center through the FAA Regional Office in 1981. The FAA was concerned with the safety and economic impact of adverse weather in the Denver air traffic control (ATC) environment (Figure 1). Stapleton Airport is a particularly difficult terminal from a weather standpoint because it has a tendency during bad weather to adversely affect the Denver Center's operation, and this frequently affects transcontinental traffic as well. Also Stapleton is a big hub operation for three airlines.

There are four significant and typical weather situations. One that occurs everyday involves wind shifts which force runway changes, and occur quite frequently during heavy traffic hours (i.e., noon and the evening rush hour). Severe thunderstorms, severe mountain wave turbulence, and upslope storms are the other three. We have had three significant upslope cases since January 1, 1985, which severely disrupted operations in the Denver Center area. The FAA real operational requirement is for timely detection and prediction (0-2 hours for safety, and 0-6 hours for economic reasons).

Figure 2 shows a hard copy printout of display data provided to the Denver Center since the Spring of 1982 when the first system was installed. The circle is the TRACON area, the isolines are weather radar reflectivity data (20,40,60 dBZ), with Stapleton in the center. On this particular day, there was a level-6 thunderstorm right over the outer marker. We are displaying flow lines, and the Limon Radar is shown along with mesonet temperatures, humidity, and wind information.

During the 30 months of the initial display evaluation, the system operated 24 hours a day, seven days a week (Figure 3). There were 150 significant cases reviewed. Of those 150 cases, 38 were analyzed in detail, 25 of which were reported on to the FAA. Of the 38 representative events analyzed, 14 were thunderstorms, 12 were wind shear/wind shifts, 7 were upslope cases, and 5 were combined thunderstorm/upslope cases. There was a positive impact on operations in 33 of the cases based on the

Adverse Weather Seriously Impacts:

- Both safety and cost operations in Denver ARTCC area
- Disrupts Denver Stapleton Airport operations
- Frequently affects transcontinental traffic flow

Four Significant Weather Situations:

- Approach area wind shear/abrupt runway wind shifts
- Severe thunderstorms
- Upslope storms—widespread low visibility/precipitation

Timely (0-6 hour) Detection and Prediction Can:

- Improve safety
- Decrease delay costs

Figure 1. Operational requirement.

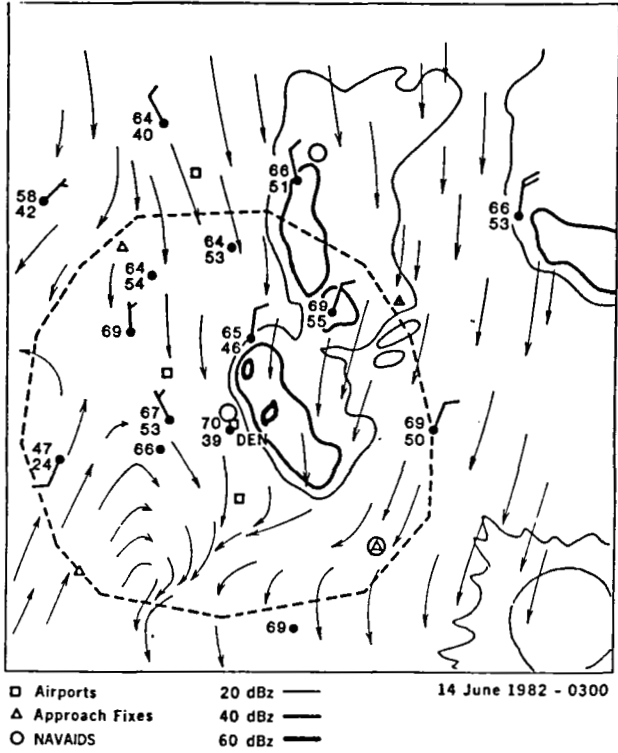

Figure 2. Typical PROFS mesoscale graphic product covering Denver Stapleton area. Limon radar is in circle at bottom right.

- 30 Months—Daily use supporting Stapleton traffic operations
- Over 150 significant cases analyzed
- 38 serious events chosen for analysis strong operational impact
- Representative Events
 - 14 Thunderstorms
 - 12 Wind Shear/Wind Shifts
 - 7 Upslopes
 - 5 Combined Thunderstorm/Upslope
- Positive Impact—33 Cases
 - 12 Thunderstorms
 - 5 Terminal Wind Shears
 - 6 Wind Shifts
 - 6 Upslopes
 - 4 Combined

Figure 3. Real-time weather impact.

- Conventional Radar Cell Tracking very valuable in predicting arrival gate and terminal operations restrictions.
- Automated Surface Observations (mesonet) critical for low ceiling and visibility onset/cessation.
- Automated Radar and Surface Data combines/overlays—extremely valuable determining cell development and tracking.
- Profiler Winds effective for flight path prediction, forecasting upslope, thunderstorm cell tracks.
- Doppler Radar needed to better forecast airport wind shift timing and locate low-level wind shear areas.
- ATC confidence level increases with timely accurate tailored information.

Figure 4. Product utility.

Case file sequence begins at 17:40:58 (1141L). The synoptic situation had been analyzed early in the period and a strong frontal passage was inevitable. Timing of the event remained questionable due to sparse conventional data north and east of the Denver Stapleton Airport in northeastern Colorado, western Nebraska and southern Wyoming. The Denver ARTCC meteorologist began surveilling the northern portions of the mesonet display during early morning hours and first detected a FROPA at about 1730Z. This information was used to provide a forecast to Denver tower and ARTCC traffic management that the front should reach Stapleton between 2030Z and 2100Z with resultant wind shift and possible reduced visibility due to blowing dust. No precipitation was forecast for the frontal passage due to low moisture availability. At 1935Z the CWSU meteorologist issued a center weather advisory (see below) based on 180° wind shear at 33 kn between LGM and LVE on the mesonet per FROPA at Denver at 2030Z.

Denver ARTCC and Denver tower personnel began to formulate traffic flow restrictions and runway configuration plans immediately and traffic speed reductions as well as expanded quota flow from CF² after the 2000Z hour to avoid sector saturation and excessive airborne delays.

The front passed Denver at 2027Z, within 3 minutes of forecast with visibility reduction to 1 nm. Some airborne delays were experienced for a period of time due to single runway operations but traffic flow was maintained smoothly throughout and system perturbations were effectively minimized.

The meteorologist knew it would be a strong frontal passage from synoptic data. Where mesonet really helped was with timing, and also the amount of shear.

Apparently the front was first detected in NRN portions of mesonet around 1730Z and an initial FROPA estimate for DEN was made.

At 1930Z, what really prompted the CWSU to issue the CWA was the 1915Z mesonet - - notice the 180° shear at 33 kn between LGM and LVE.

Front passed Den at 2027Z, 3 minutes before fcstd in CWA.

W2 CWA...1935Z MON SEP 19 1983...AN EXTREMELY STRONG FRONTAL BOUNDARY WITH WIND SHEAR TO 70-80 kn CURRENTLY MOVG THRU NRN PTNS DEN TRACON AREA...WINDS WITH FRONTAL PASSAGE SHIFT TO N-NE AT 30-40 kn ...FRONT EXPCD BY DEN STAPLETON AT 2030Z...CAUTION FOR EXTRM LO LVL TURBC AND BLWG DUST. ZDV CWSU 191935Z

Figure 5. Case Description from Denver Stapleton, September 19, 1983. (Transcribed from computer printout)

analyses performed by the CWSU and ATC people at the center.

From a product utility standpoint (Figure 4), conventional radar cell tracking was extremely valuable for predicting arrival gate and terminal operations restrictions, particularly during rush hours. Automated surface observations (mesonet) were critical for low ceiling and visibility onset and cessation. The automated radar and surface data combinations were the most valuable for predicting cell development and track information. Profiler winds were quite effective for flight path prediction, input to the ATC 90/20 computer forecasting upslope conditions, and thunderstorm cell tracking. The center would like to have Doppler radar information for wind shear forecasting, etc. We do not plan to provide that capability for several years. The ATC Weather Information confidence level has increased steadily with the timely PROFS information.

Figure 5 is a case description for September 19, 1983, and Figures 6 - 9 are actual hard copies of the information used in the control room. On each display it is noted that the data are PROFS experimental data. What I would like to show you in these figures is how accurately we were able to predict wind shifts which caused runway changes. Figure 6 shows that at approximately 17:40 Z, which is about 11:40 a.m., a front was moving down from the north. You will note that although the Limon radar was operative, no echoes were showing from the radar. Within one hour and 15 minutes the frontal system moved down into and across the TRACON area. At 19:35 Z, the frontal passage was forecast for Stapleton at 20:30 Z (Figure 7). Figure 8 shows that at 19:27, the system is continuing to move; and at 20:19, Figure 9 shows that there has not been a shift at Stapleton, but there has been a wind shift just to the north at Brighton. This was predicted roughly 55 minutes in advance. The CWSU has been forecasting this type of wind shift consistently for the past two years.

We are currently in the Denver Center Phase II Program (Figure 10), which involves a full PROFS work station providing radar, mesonet, satellite and AFOS products. We provide time series analyses of each of the mesonet stations, and are depicting all the profiler stations' data. We actually have four profiler stations in operation now, and the network is being reconfigured with additional stations. We are not providing Doppler radar coverage now, as mentioned earlier; however, we may provide some output information from CP-2 this summer. We are providing automated PIREP information to the center. In summary, we have been focusing on display information for the CWSU work station, output products to the ATC system, and developing functional specifications for the FAA CWSU work station of the future.

Question from the floor: Mike Tomlinson, NWS

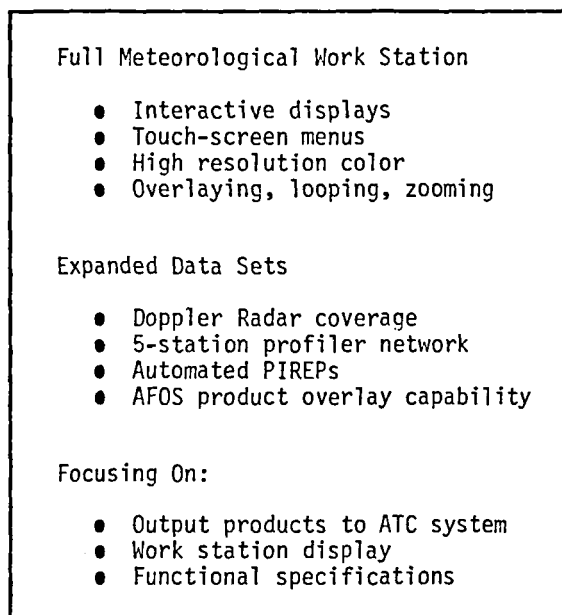

Figure 10. Current Phase II Program.

Everything you have shown seems to concentrate almost exclusively in the Denver Stapleton area, and the Denver ARTCC area is considerably larger than that. Do you have similar types of capabilities to cover the rest of the area; and, if not, what kind of impact is this concentration of that one terminal having on the services provided for the remainder of the Denver ARTCC area?

Response: Jack Hinkelman

The Denver Center area may be unique because Stapleton is the primary throttling feature in the Denver Center area. It is the big terminal. Of course, there are Colorado Springs, Cheyenne, Pueblo, Grand Junction and other terminals; but Stapleton is the sixth or seventh most congested airport in the world. It is about the fifth in the U. S., and is a big problem area. They are normally operating at approximately 80-90 aircraft per hour almost continuously from 7:00 a.m. to 8:00 p.m. They are always operating at maximum capacity. Whenever there is a weather problem at Stapleton, both the en route system and the terminal system in that area becomes very unstable, and may stay that way for about four to five hours even after the weather dissipates. Therefore, we have concentrated on the Stapleton area. Although I have not shown any cases, we have several where thunderstorm track is predicted over the arrival and departure gates. Also, we are able to predict thunderstorm tracks out over the en route area, particularly to the east. It is more difficult out over the west. Most of the thunderstorms form in the mountains.

We have intentionally, at their request, concentrated on the Stapleton operation. It very frequently affects transcontinental operations. There is also profiler data which covers the whole center area, and that has been put into the 90/20. When the forecast winds appear to have been in error, we have been able to insert real-time profiler data in the 90/20 and the ATC computers settle down. We do not have radar data that covers the entire center area, so we can work only with what we have.

Question from the floor: Doug Lundgren, AOPA

What do you see in a broader, national scale for the future of a PROFS-type effort, particularly the mesonet? We can place sensors around a particular airport; but how can we correlate this with more sensors nationwide?

Response: Jack Hinkelman

As you know, PROFS is an experimental prototype of the AWIPS-90 program, which is the NWS program for implementation in the 1990's. In fact, there are mesonetworks around almost all major metropolitan areas in the country. EPA and other groups all have mesonets. I think a good part of the state of Tennessee

is covered by automated surface observations, like the Tennessee Valley Authority (TVA). There is almost a full mesoscale network covering the state of Tennessee. There are four or five groups and none are reporting into a central computer. I think Sandy MacDonald could verify this, but we believe there is extreme value in mesonetworks. We don't see any national program to implement mesonetworks around major cities or airports, but it certainly would not be a bad idea. Maybe it will come about.

THE FAA/M.I.T. LINCOLN LABORATORY DOPPLER WEATHER RADAR PROGRAM *

James E. Evans
Massachusetts Institute of Technology (M.I.T.) Lincoln Laboratory

The Federal Aviation Administration (FAA)-sponsored Doppler weather radar program at M.I.T. Lincoln Laboratory focuses on providing real-time information on hazardous aviation weather to end users such as air traffic control (ATC) and pilots. Figure 1 summarizes the principal elements of the real-time system under development by the FAA to convey radar-derived weather information to the end users.

The existing Weather Surveillance Radar / Air Route Surveillance Radar (WSR/ARSR) network which provides real-time reflectivity data via the Remote Radar Weather Display System (RRWDS) will be replaced by Next Generation Weather Radar (NEXRAD) in the latter half of this decade. At the Central Weather Processor (CWP), the data from various individual RRWDS and NEXRAD sites which are germane to a given Air Route Traffic Control Center (ARTCC) will be put together to provide various composite maps (e.g., low- and high-altitude hazardous weather regions) with a spatial resolution of approximately 4 km. The weather hazards of principal concern for initial NEXRAD deployment include:

- Heavy rain and hail
- Turbulence
- Low-altitude wind shear (microbursts, downbursts, gust fronts)
- Mesocyclones and tornadoes
- Short-term (10-30 min.) predictions of the locations of the above phenomena.

Preliminary estimates suggest that 9 to 40 NEXRAD sites will be used to generate the mosaic at each of the 20 ARTCC's in the United States.

In the near-term, the ASR-9 with a special weather channel will be a principal source of radar data for terminal controllers and control towers. When NEXRAD and the CWP are deployed, the CWP radar mosaic data will augment the ASR-9 data. However, reliable detection of short-lived wind shear phenomena will necessitate the use of a dedicated terminal Doppler weather radar (TDWR) at a number of major airports.

* The work described here was sponsored by the Federal Aviation Administration. The United States Government assumes no liability for the contents or use of these reported results.

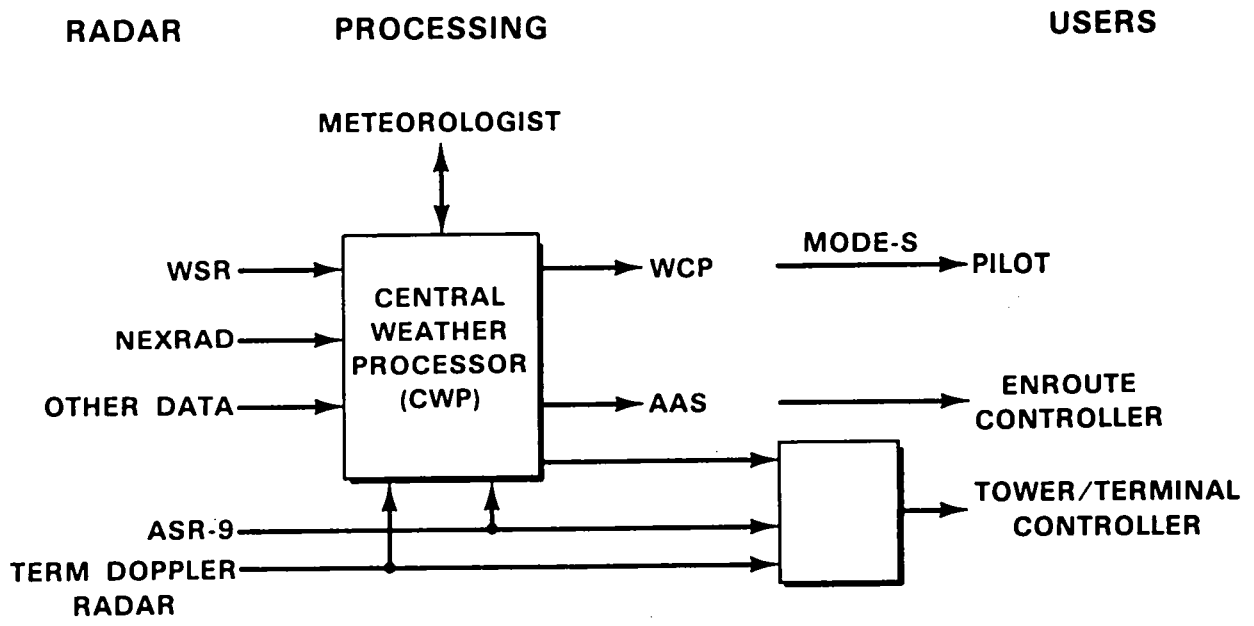

Figure 1. FAA Real-Time Radar-Derived Weather Information System.

This real-time use of weather radar data differs from that by the National Weather Service (NWS) and USAF Air Weather Service (AWS) in several important respects:

1. The user uses data from the mosaic of many radars rather than a single radar alone and may not know which radars were actually used to produce the mosaic display for particular geographical area.
2. Automated hazard detection will be essential due to the large ARTCC geographical area and limited Center Weather Service Unit (CWSU) staffing.
3. The real-time data will be used by nonmeteorologists with a limited display capability for real-time weather avoidance. This usage requires rapid processing and communication of higher quality data as well as careful attention to product display simplification.
4. Short-term (i.e., 10-30 min.) prediction of hazardous regions is needed for en route flight path and airport runway usage planning so as to achieve sizable improvements in airport efficiency and reductions in aircraft fuel usage.

As a consequence of these considerations, the FAA has been carrying out a substantial R & D program for several years focused on the weather radar-derived products for real-time ATC use.

The three principal objectives of the FAA research program at M.I.T. Lincoln Laboratory are:

1. Determining the hardware and software (i.e., algorithms) for the TDWR
2. Validating and refining the algorithms for the key FAA NEXRAD and ASR-9 weather channel products
3. Assessment of the operational utility and meteorological validity of the CWP weather radar-derived products to be provided to real-time ATC users

A principal element of the FAA/Lincoln program is the measurement systems currently in operation near Memphis International Airport as shown in Figure 2. The S-band weather radar is intended to be functionally equivalent to a NEXRAD sensor. The key features of the S-band radar are as follows:



Figure 2. Memphis Weather Measurement Systems.

- A center-fed 8.5 m diameter parabolic reflector antenna which achieves the NEXRAD objective of a 1° BW and -25 dB first sidelobes with the sidelobes at least 40 dB down for angles greater than 10° from boresight
- The computer controlled mount with peak angular velocities of $30^\circ/\text{sec.}$ in azimuth, $15^\circ/\text{sec.}$ in elevation and peak accelerations of $15^\circ/\text{sec.}^2$ in both axes which can execute a variety of scan strategies
- A klystron transmitter with 1.1 mv peak power for $0.8 \mu\text{s}$ pulses at rates up to 1200 pulses/sec. This klystron (from an ASR-8 system) has the spectral stability for 50 dB clutter suppression with polyphase modulation for range ambiguity resolution
- Use of a low-noise receiver to yield a sensitivity close to the NEXRAD objective of 0 dB SNR on a -8 dBz target at 50 km with an "instantaneous" AGC to yield a dynamic range of approximately 90 dB
- Finite impulse response clutter filtering and auto-correlation lag estimation by a fixed-point arithmetic Lincoln-designed signal processor designed to achieve a clutter suppression of 50 dB
- Execution of computationally intensive tasks such as conversion of auto-correlation values to weather estimates, data clean-up (e.g., clutter map editing, velocity de-aliasing, etc.), resampling to a Cartesian grid and feature extraction in a Lincoln-designed data acquisition and analysis processor which utilizes multiple processing elements to achieve a 50 million operations/sec. computation rate
- A Perkin Elmer Model 3252 superminicomputer for overall system control, higher order logic in automatic detection algorithms, and driving local and remote color displays

The supporting measurement systems for testing in Memphis include:

- A .25 MW, 5 cm, 1.5° band width pencil beam Doppler weather radar from The University of North Dakota (UND) to permit dual Doppler analyses
- Remote data from an existing FAA air route surveillance radar (ARSR-1) for aircraft location
- A 30-unit mesonet (with 1 minute measurement rate) interfaced to the Geostationary Operational Environmental Satellite (GOES)
- Data recorded from an operational 6-unit low-level wind shear alert system

(LLWSAS) at the Memphis airport

- An instrumented Cessna Citation II jet aircraft from UND
- An instrumented Convair 580 turbo-prop aircraft from the FAA Technical Center

Additionally, GOES satellite images and WSR-57 (RRWDS) data are also recorded to facilitate meteorological analysis of salient weather events.

The ability to achieve an adequate weather-to-clutter ratio at the low-elevation angles and short ranges associated with low-altitude wind shear detection has been an important issue for the TDWR. The NEXRAD technical requirements call for a 50 dB clutter suppression capability with at least 45 dB clutter suppression being demonstrated in the validation phase testing. Figure 3 shows 47 dB experimental clutter suppression by the test bed against clutter from a microwave tower with a coherent Doppler shifting repeater providing a synthetic weather signal. The suppression in this case is limited by spurious lines from the production line ASR-8 transmitter/receiver used in the test bed. We believe that a transmitter/receiver designed at the outset to achieving the NEXRAD-desired capability should have little difficulty meeting the NEXRAD technical requirements. Reference [1] describes many aspects of NEXRAD clutter suppression by the use of linear time invariant clutter filters.

Another important issue for the Memphis measurements is the extent to which the low-altitude wind shear phenomena of greatest concern, microbursts/downbursts, occur in a moist meteorological environment such as Memphis. These phenomena were found to be fairly frequent in the dry subcloud environment of Denver; however, there is currently considerable uncertainty regarding the frequency and (dynamic) generation mechanism for moist subcloud environment microbursts/downbursts. Figure 4 shows some very preliminary statistics on high-wind events observed on the 25 station mesonet which was operational in the May-November 1984 time period. These data have not been corrected for site obstruction effects; it is anticipated that more events and more sensors/events will be found in the final summary of the 1984 data.

Figure 5 shows preliminary results of analysis by Marilyn Wolfson of a microburst that induced a 30.2 m/sec. (68 mph) peak wind at mesonet station No. 25 at 1806 CST on 20 October 1984. This microburst was encountered at the end of Memphis runway 27. Before the onset of the microburst, the environmental wind was 7 to 9 m/sec. (16 to 20 mph) from the southerly direction. In two minutes, the wind reached its peak, followed by a decrease to below 15 m/sec. (34 mph) in the next two minutes. The duration of this microburst, defined as the period of

ILLUSTRATION OF 47-dB CLUTTER SUPPRESSION

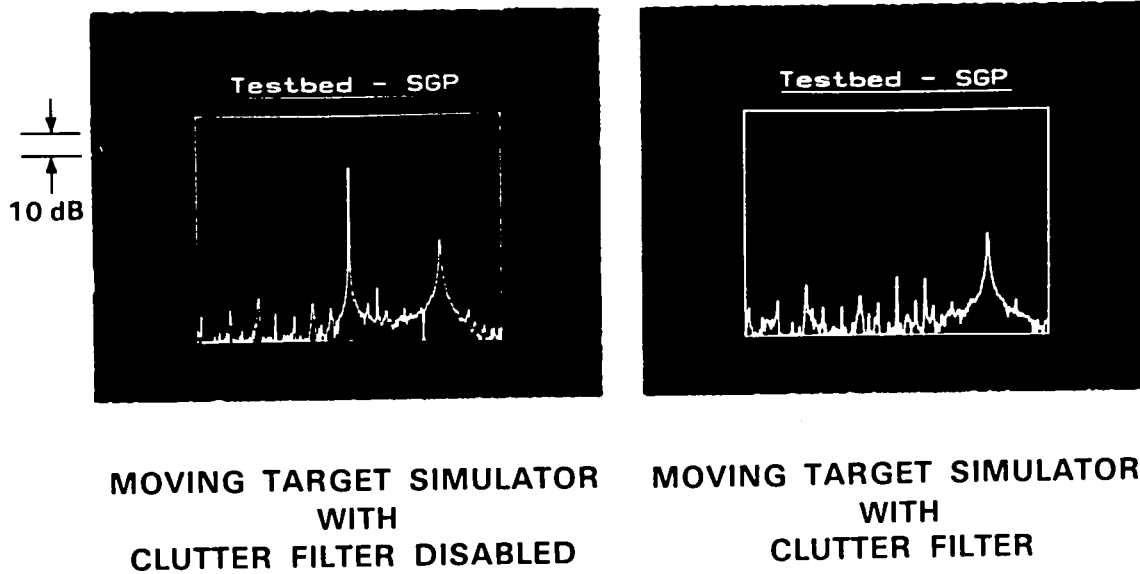

Figure 3. Illustration of 47-dB Clutter Suppression.

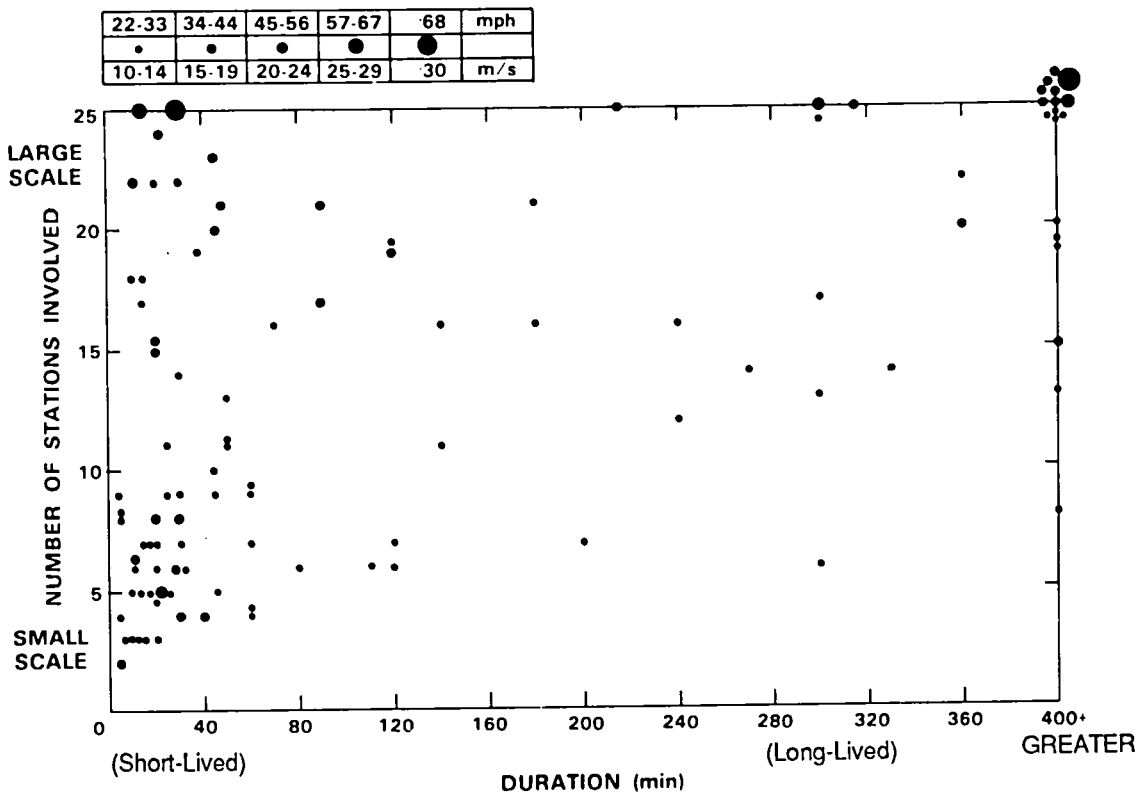

Figure 4. Temporal and Spatial Scales vs. Intensity of Mesonet Wind Events, 1984.

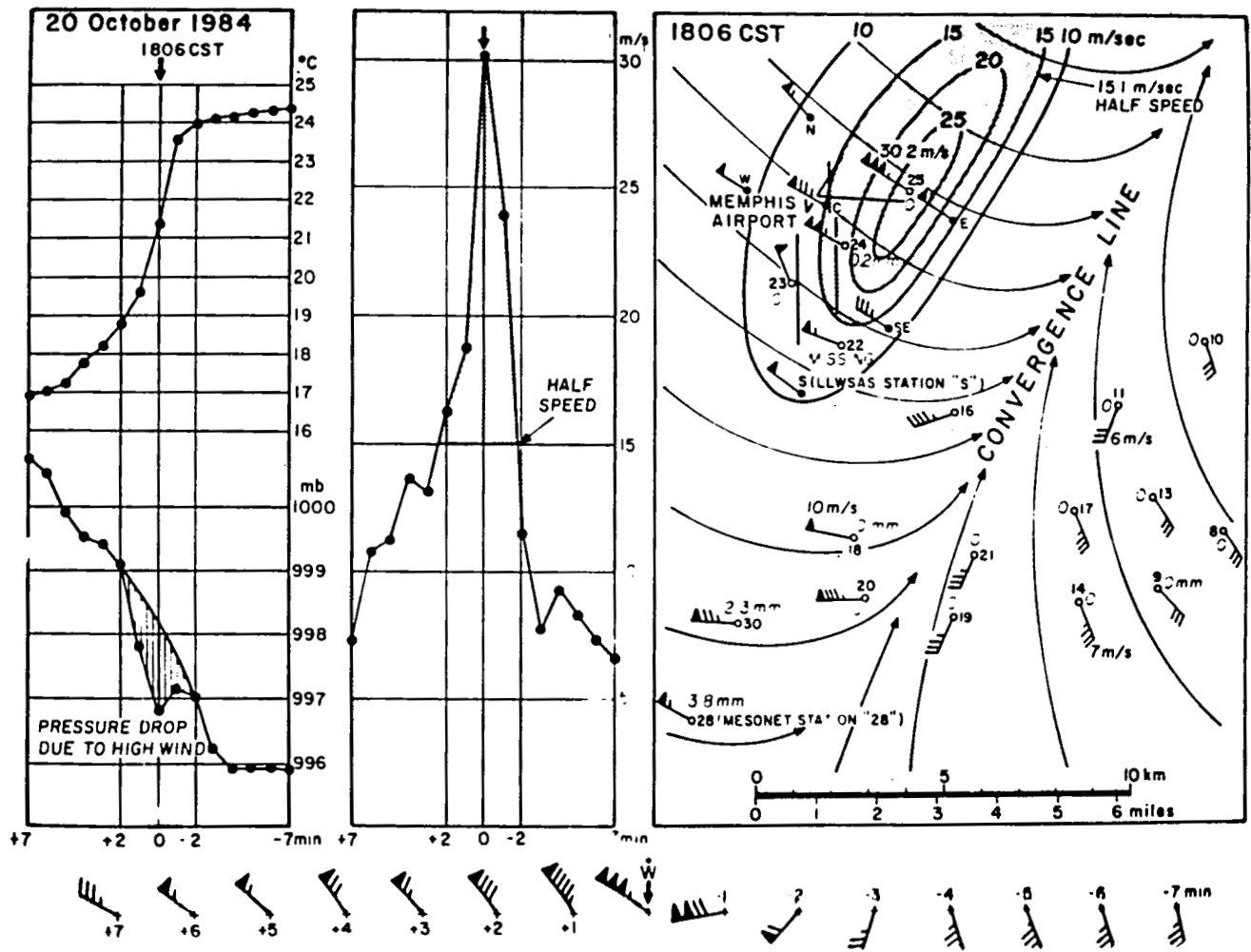

Figure 5. Microburst at Memphis International Airport.

one-half of the peak windspeed, was four minutes.

A detailed analysis of the mesonet data revealed that the microburst was located just behind a gust front which swept across the Memphis area. Consequently, the area of the microburst, after its dissipation, was replaced by the cold air pushing behind the gust front. Both temperature and pressure changes were characterized by those of a gust front except for a significant pressure drop during the microburst winds.

This microburst was accompanied by a very strong wind shear at low altitude. A hypothetical aircraft penetrating the storm from southeast to northwest would experience a 20 m/sec. (39 kts) increase in headwind, followed by a 15 m/sec. (29 kn) loss of headwind within approximately 3 km (10,000 ft.).

Typical results from one of the correlation tracker/reflectivity map extrapolation algorithms developed at Lincoln for use in NEXRAD are shown in Figure 6. The algorithm determines the velocity vectors associated with various cells by cross-correlating the data from different measurement times and then predicts the reflectivity map at a future time by moving appropriate features of the current map according to the estimated velocity vectors. A Lincoln report [2] describes this and several other tracking techniques, as well as the capability of this extrapolation technique to provide useful 10- to 30-minute predictions.

Assessment of the utility and validity of the weather products to be supplied to ATC users is an important element of the FAA/Lincoln program. Figure 7 shows a block diagram of the testbed system emphasizing the various display options which will be utilized in the next few years.

Information on aircraft position are obtained from the common digitizer (CD) output of a FAA ARSR for use in tracking the instrumented aircraft and providing position reports for ATC aircraft/weather displays. Figure 8 shows a strawman display format for weather and aircraft data developed by MITRE Corporation researchers in McLean, Virginia. Work is currently under way at Lincoln Laboratory to develop weather image coding techniques which could be used to transmit images to aircraft over the Mode-S data link. We hope to carry out real-time testing of the capability as a part of the Mode-S data link flight test program which will commence this year.

In summary, the FAA is actively engaged in the engineering application of Doppler weather radar research work to achieve an order of magnitude improvement in detection of hazardous aviation weather and provision of the results to principal ATC users. A principal focus for this work is the test bed radar and supporting sensors which will be used for measurements in key meteorological regimes over

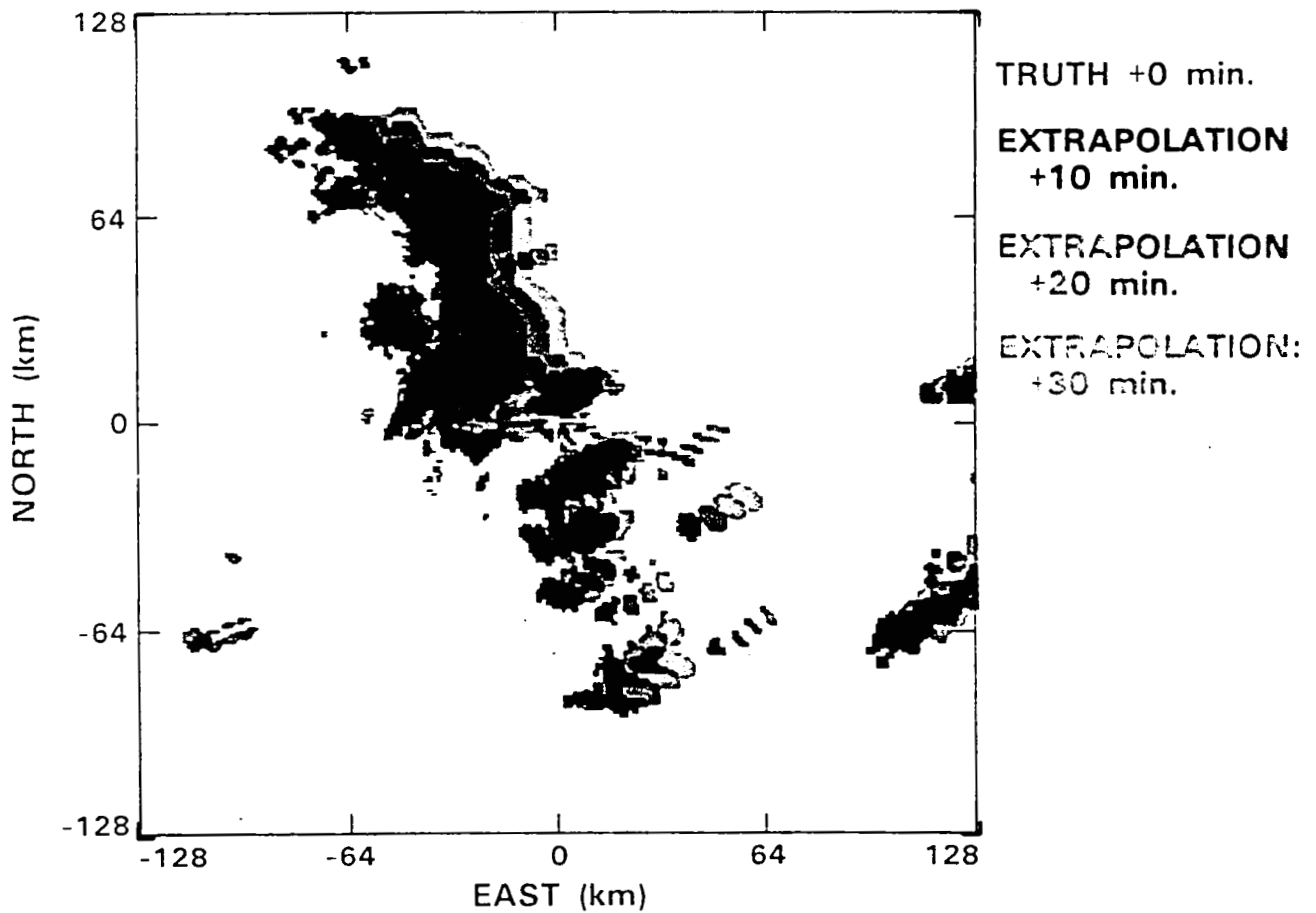

Figure 6. New England Squall Line Extrapolation.

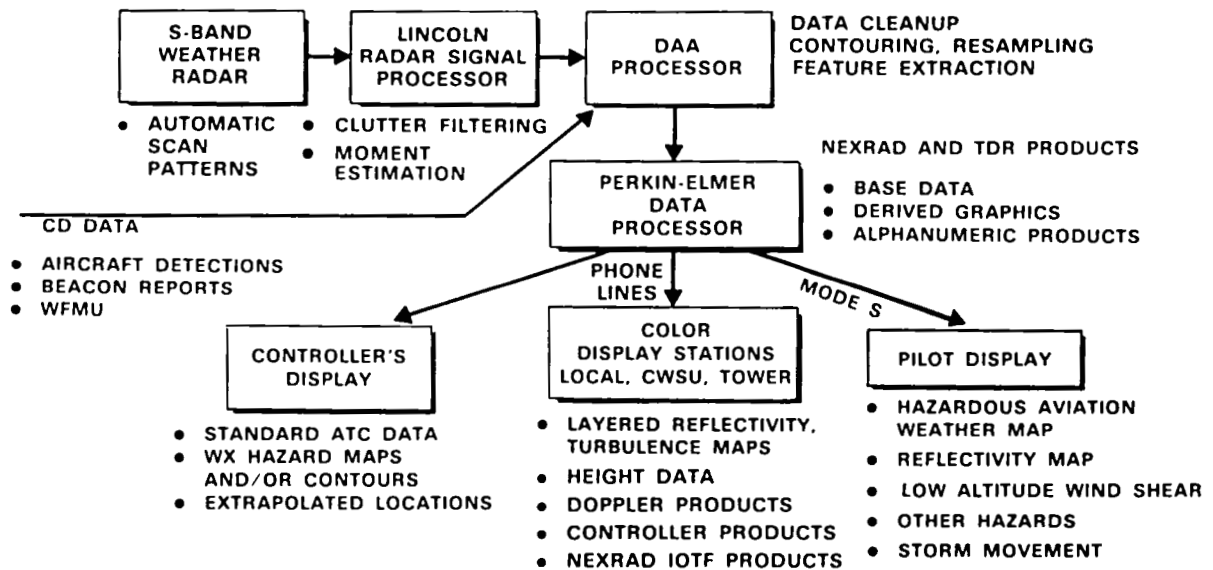

Figure 7. Eventual Configuration for Display of ATC Weather Products at Testbed.

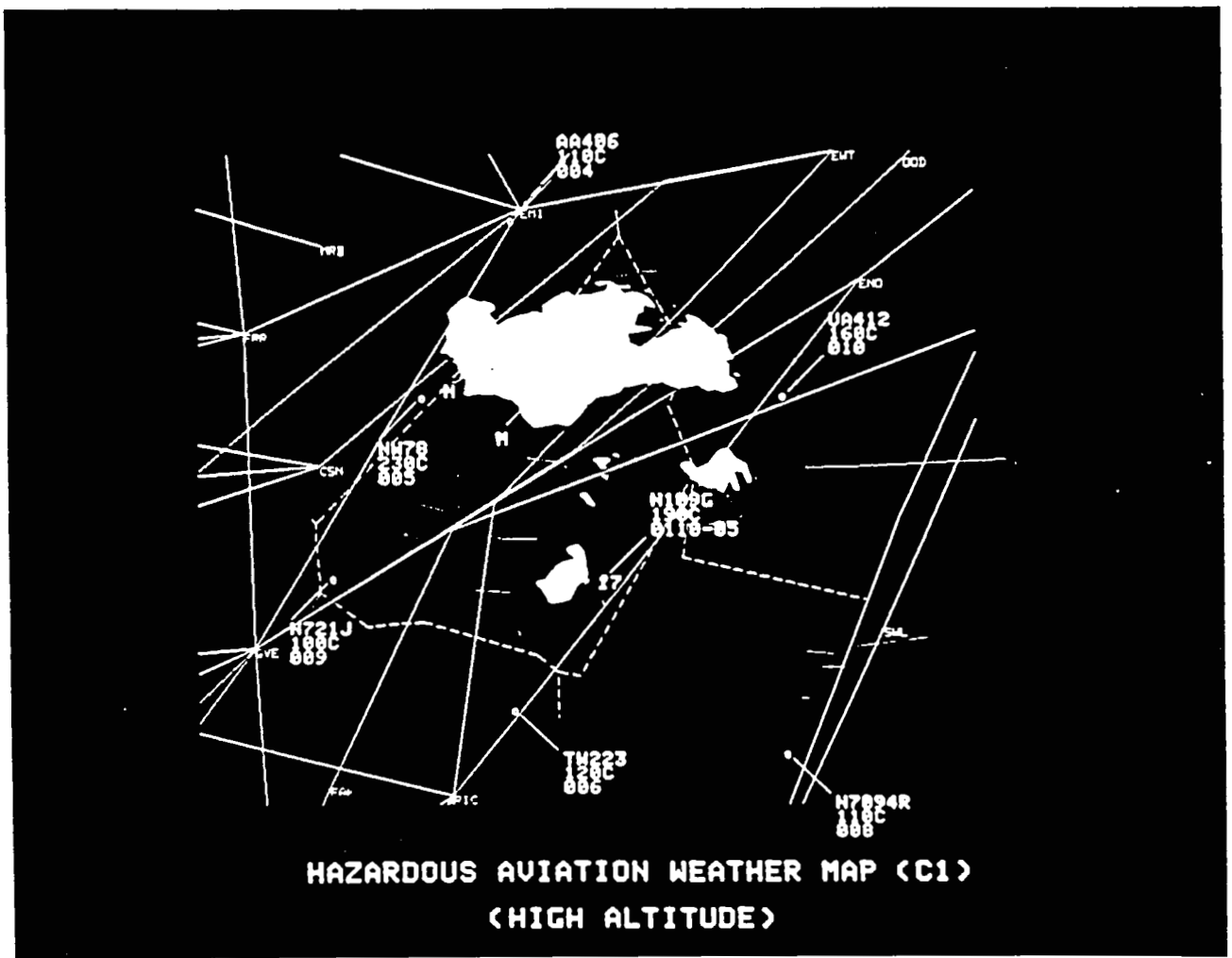

Figure 8. Example of ATC Weather Display.

the next few years to refine and validate the product generation algorithms and displays.

The transportable test bed radar is largely due to the concerted efforts of W. Drury, M. Merritt, P. La Follette, A. Dockrey, W. Rataj and F. Groezinger. M. Merritt provided the clutter suppression results in Figure 3 while M. Wolfson accomplished the 20 October 1984 microburst analysis. The mesonet data summary in Figure 4 is due to B. Forman, J. DiStefano and M. Wolfson while M. Goldberg provided the correlation tracker results shown in Figure 6.

References

1. Evans, J. E.: "Ground Clutter Cancellation for the NEXRAD System," Project Report ATC-122, Lincoln Laboratory, M.I.T., 19 October 1983.
2. Brasunas, J. C.: "A Comparison of Storm Tracking and Extrapolation Algorithms," Project Report ATC-124, Lincoln Laboratory, M.I.T., 31 July 1984.

SECTION VI
COMMITTEE SUMMARY REPORTS

COMMITTEE SUMMARY REPORTS

COMMITTEE: OBSERVING WEATHER

CHAIRMAN: Alexander E. MacDonald

MEMBERS:

Ward Baker

Bill Boyd

Mike Connelley

Larry Denton

Jim Evans

Morton Glass

Ron Lavoie

Steve Short

ISSUE:

Can profilers provide the added temporal and spatial density of wind data and short-term forecasts for lower-level flights for both flight economy and safety?

DISCUSSION:

It is unlikely that profilers will be able to satisfy the need for both boundary-layer and jet-stream-level winds at reasonable cost.

Most likely, profilers will provide highly accurate winds above 2,000 ft.-3,000 ft., but only at profiler sites which may be 200 km or more apart. Local terrain effects may not be resolved with such a network.

NEXRAD will have the capability of observing clear-air wind profiles in the lower few thousand feet on most days.

RECOMMENDED ACTION:

Explore techniques for combining the temporal density of profiler measurements in a network configuration with diagnostic models to generate mesoscale wind fields.

Ensure the development of NEXRAD techniques to provide low-level clear-air wind fields.

RESPONSIBLE AGENCIES: NOAA

PRIORITY: Very High

ISSUE:

Implement automated observations into nationwide operations.

DISCUSSION:

Automation offers opportunity for substantial improvement of services. It allows for expansion of services into smaller airports (e.g., FAA; AWOS Program; and non-federal programs), as well as expansion of hours at many part-time FAA and NWS locations. This opportunity, however, entails certain risks that need to be managed carefully. Specific concerns are

- Need for completeness of observation where required to support commercial operations
- Need for representativeness of the automatically provided visual element (e.g., index of visibility, ceiling conditions)
- Need for sufficiently rigorous system standards and ongoing operational quality control

RECOMMENDED ACTION:

- Strong support is made for AWOS-level automation at unmanned airports (however, inclusion of lightning detection is recommended).
- For current manned observation sites, observer augmentation of the system (both AWOS and ASOS) as necessary for critical information such as precipitation discrimination, and retention of remarks (e.g., fog bank east).
- Need exists for validation and demonstration of sensed parameters for representatives of observation, and use of multiple sensors as necessary (e.g., multiple visibility sensors where non-homogeneous conditions are common).
- Require sufficiently stringent design standards and institute rigorous operational quality control procedures sufficient to meet the aviation safety requirements.

RESPONSIBLE AGENCIES: FAA, NWS

PRIORITY: Very High

ISSUE:

Need to notify pilots of hazardous ground or flight conditions resulting from thunderstorm activity at/in the vicinity of unmanned airfields.

DISCUSSION:

Automated Weather Observing Systems (AWOS) are scheduled to be implemented at selected non-towered airfields in the near future. These systems will provide very useful weather information; however, the capability to detect thunderstorm activity is presently not planned. This capability can be readily included either by use of an on-site lightning detector, or potentially, for large areas of the United States, by extracting lightning information from regional lightning networks operated by other agencies (e.g., BLM, DOD).

RECOMMENDED ACTION:

- Incorporate lightning detection capability into AWOS package
- Include important automatically generated remarks (e.g., “thunderstorm NW”)

RESPONSIBLE AGENCIES: FAA

PRIORITY: High

ISSUE:

Users, particularly those from the general aviation areas, need better en route weather data. Satellite imagery could be part of the integrated solution.

DISCUSSION:

With advanced integrated information systems likely in the 1990's, it will be possible to identify aviation hazards such as thunderstorms and areas of icing using satellite images as part of data input. Polar orbiting microwave sensors may contribute to such identification.

RECOMMENDED ACTION:

- Improve integration of mesoscale data.
- The Central Weather Processor program should support development of hazardous weather diagnosis using satellite imagery, radar and other sources.

RESPONSIBLE AGENCIES: NWS, FAA, NESDIS (NOAA)

PRIORITY: High

ISSUE:

Will the profiler provide improved cruise-level wind observations and forecasts for jet aircraft?

DISCUSSION:

- There are several variable design parameters that remain to be decided in building a commercial wind profiler. Among the trade-offs will be accuracy versus averaging time, upper-altitude winds versus boundary-layer winds, vertical resolution versus cost, etc.
- Present interest for passenger airlines is in the 28,000 ft. to 40,000 ft. altitude; for corporate jets, it extends to 51,000 ft. Interest is greatest in forecasts 6-8 hours ahead for flight planning purposes; they are needed at least 4 times per day. Changes in avionics and aviation procedures may soon make observed wind fields more important as opportunities to adjust flight plans in real-time become more feasible.
- Uncertainties in the accuracy of wind information are usually reflected in safety factors such as extra fuel loading.

RECOMMENDED ACTION:

The profiler design should ensure that winds are routinely measurable at altitudes up to 17 km.

RESPONSIBLE AGENCIES: NOAA, FAA

PRIORITY: High

ISSUE:

Temperature forecasts at high altitudes are critical for high-level corporate aviation flights.

DISCUSSION:

For flights between 35,000 and 51,000 ft., temperature forecast accuracy within $1^{\circ}C$ is desirable due to performance characteristics of aircraft. All methods of improvement should be explored including temperatures via vertical profilers, satellite data, and radiosondes.

RECOMMENDED ACTION:

Continue research in integration of vertical profilers, satellite, and radiosonde

data for better inputs to numerical models.

RESPONSIBLE AGENCIES: NOAA

PRIORITY: Medium

ISSUE:

Lightning detection and forecasting, and its effects on composite aircraft and microelectronics.

DISCUSSION:

Aircraft avoidance of thunderstorm activity is always desirable. The planned use of automatic weather observing systems with lightning detection capability will rely on cloud-to-ground detection technology. These sensors will not detect exclusive cloud-to-cloud lightning activity. In addition, aircraft operating within clouds of high lightning potential may trigger the static discharge. While this phenomenon is normally not hazardous, the potential does exist to damage microprocessor or other electronics equipment onboard aircraft.

RECOMMENDED ACTION:

Develop technology for detection of cloud-to-cloud lightning activity as well as detection of high-potential static fields.

RESPONSIBLE AGENCIES: NASA, FAA, NWS

PRIORITY: Medium

ISSUE:

Can profilers help in detecting and predicting clear-air turbulence?

DISCUSSION:

- Since the wind profiler is based on Doppler radar principles, its signal contains some information on wind variability as well as mean motion. This spectral width information has not yet been sufficiently studied.
- The wind profiler also gives information on the time rate of change of vertical shear of the horizontal wind, which could lead to useful forecasts of bulk Richardson number that relate to the onset of turbulence.
- Gravity waves can also be detected with the profiler and these can be important sources of turbulence for aircraft.

RECOMMENDED ACTION:

Research should be undertaken on the information content of wind profiler data for the detection and prediction of clear-air turbulence.

RESPONSIBLE AGENCIES: NASA, NOAA, FAA

PRIORITY: Medium

.....

COMMITTEE: PRODUCTS AND SERVICES

CHAIRMAN: Col. John W. Oliver

MEMBERS:

C. L. Chandler
Jack Connolly
Steve Fuller
Bill Hall
Russ Hovey
Kelly Klein
Walter Lyons
Ron Sznaider
Dave Winer
Don Wylie

ISSUE:

The government is proceeding with Mode-S acquisition program, which is an obsolete technology for passing meteorological data to the pilot.

DISCUSSION:

Not a single user (aviation) committee was an advocate of Mode-S.

Limitations reduce potential utility:

- Interacts with aircraft on an individual basis; i.e., no “broadcast” capability
- Limited data through-put function of short exposure time in revolving antenna beam
- Vast user needs not sized and cannot be fully satisfied

Concepts of operation have not been published:

- Not coordinated with users
- Not compatible with stated user needs

Mode-S specifications were developed approximately 10 years ago and have not been updated.

RECOMMENDED ACTION:

Abandon the Mode-S program for meteorological information distribution. Invest money in more efficient and effective means to interchange data between ATC and cockpit.

RESPONSIBLE AGENCIES: FAA

PRIORITY: High

ISSUE:

There is a need for 6-hour updated global temperature/wind forecast fields.

DISCUSSION:

These updates are needed for computer flight planning, and they would reduce forecast time period for a better product and save airlines millions of dollars:

- 6-hour updates must include “off-time” sources of wind/temperature data such as PIREPs, profilers, special rawinsonde runs, R&D set-ups, etc.
- Incremental improvements must be weighed against “opportunity costs” such as delays in other products/services that may result.

RECOMMENDED ACTION:

Submit this recommendation to NWS for consideration.

RESPONSIBLE AGENCIES: NWS, NMC

PRIORITY: High

ISSUE:

Pilot reports for winds aloft are important for full conservation flight planning; but are underutilized.

DISCUSSION:

- Pilots and airlines are generally not enthusiastic about sending in PIREPs because they are not convinced that the reports are used. Typical response: "I sent in a report, but I can't find any evidence that it is in the system."
- INS-derived winds are accurate and can be relied upon.
- NWS claims that PIREPs are entered in the computer, but the effect of any one report on a forecast is not going to show up as a significant "perturbation."
- An important problem is the perception that the PIREP system is unfair; i.e., the airlines pay ARINC for PIREP transmissions, then the ARINC charges the same airlines for the data. Some airlines choose to use a self-contained system instead and do not participate in the ARINC pilot reporting system.
- Improved winds/temperature forecasts offer tremendous cost savings opportunity in route/mission planning for the entire aviation community.

RECOMMENDED ACTION:

NWS should prove to the aviation community that PIREPs are used effectively in upgrading the forecast products.

RESPONSIBLE AGENCIES: NWS, FAA

PRIORITY: High

ISSUE:

NEXRAD-derived parameters are needed by the meteorological community to improve forecasting of turbulence, icing, low-level wind shear events, and severe thunderstorms/tornadoes.

DISCUSSION:

It was noted by pilots and meteorologists that the state of forecasting turbulence (clear-air turbulence, in particular), icing conditions, and low-level wind shear has not changed significantly in over three decades and that better forecasting skills must be developed. Operational forecasters require additional meteorological data for analysis and on which to base predictions. NEXRAD Doppler radar will provide additional information useful to a meteorologist in the detection and forecasting of wind shear, turbulence and severe weather. Doppler radar provides the best known means of detecting microburst events which are potentially devastating to the flying community. NEXRAD offers diagnostic software that, in turn, offers valuable analysis information and reduces manpower requirements.

RECOMMENDED ACTION:

Continue support of NEXRAD project to aid in the detection, nowcast, and forecast of weather phenomena dangerous to aviation.

RESPONSIBLE AGENCIES: FAA, DOD, DOC

PRIORITY: High

ISSUE:

Currently available monitoring, display and dissemination technologies are often going largely unutilized to meet currently articulated and well-defined needs.

DISCUSSION:

There are a large number of major atmospheric technology systems currently under development for the various sectors of the government. Examples include NEXRAD, AWIPS-90, AWDS, SWIS, etc. While holding great promise to solve urgent problems, these systems may not be deployed until the next decade. Furthermore, the cost per unit of each copy will be so high as to prevent their widespread use at many smaller installations. Today, however, products and services are already being produced by the private sector which meet major portions of these systems requirements, at only a fraction of the cost. Examples of products and services for which immediate needs have been vocalized include:

- Low-cost GOES image animation
- Dial-up color digital remote radar systems
- Lightning tracking networks and real-time distribution and display
- Satellite delivery of GOES imagery and alphanumeric data to low-cost earth work stations
- Dial-up interactive data bases for aviation weather data, forecasts

RECOMMENDED ACTION:

Recognition should be given to the practicality and cost-effectiveness of supplying available "off-the-shelf" (comparatively) low-cost systems to meet existing needs during the interim period before the deployment of major hardware/communications technologies. Thereafter, the interim systems can be transferred to smaller stations which would otherwise be unserved.

RESPONSIBLE AGENCIES: DOC, NWS, FAA

PRIORITY: Medium

ISSUE:

There is a great need for improved data communications for weather data both to and from the NWS. While the NWS adequately collects NWS data, data from other sources such as other government agencies and the private sector, including airlines, are often lost. Also, the distribution of the data to the end user should be examined.

DISCUSSION:

It was agreed that the NWS data are generally acceptable except as noted in other issue items. Much data from PIREPs and other meteorological data networks are excluded by design or default from the NWS/FAA data files. The user groups believed that the private sector does a superior job of distributing data in a usable form to the end user for preflight functions. In the en route phase, ACARS are found to be very valuable and satellite systems hold great promise for retrieval of data. The general aviation and corporate users were much more in favor of ground-based NWS radar being transmitted to the cockpit than were the scheduled carriers. This is believed to be due to the nature of the flight than to the need for the data.

RECOMMENDED ACTION:

The FAA should encourage the distribution of digital data by the private sector.

RESPONSIBLE AGENCIES: FAA

PRIORITY: Medium

ISSUE:

Hazardous weather information, which is available in the National Airspace System (NAS), is not always available to the pilot (aircrew) on a timely basis.

DISCUSSION:

The Center Weather Service Unit (CWSU) in the ARTCC has up-to-date weather information including near real-time weather radar displays, satellite weather pictures, facsimile weather charts, pilot reports, and alphanumeric weather data. The CWSU will soon be equipped with a remote terminal for AFOS (RTA) which will allow access to the NWS AFOS system. It will soon be equipped with a Satellite Weather Information System (SWIS) to provide loop and zoom capability. The CWSUs were established to provide near real-time weather information to the controller and to the pilot under control of the ARTCC. Links to the FSSs in the center area were also envisioned to allow FSS access to the near real-time hazardous

weather information available to the CWSU.

RECOMMENDED ACTION:

Devise procedures to allow the CWSU to broadcast timely hazardous weather information to all pilots (aircrew) under center control.

RESPONSIBLE AGENCIES: FAA

PRIORITY: Medium

ISSUE:

The state-of-the-art capability for short-term (1-6 hrs.) weather forecasting does not meet the requirements of the Space Shuttle operations because of the highly sensitive nature of the Shuttle to environmental factors.

DISCUSSION:

The Space Shuttle must avoid clouds with high liquid water content which could damage its thermal protection system and adversely affect its stability and control. The Shuttle must also avoid atmospheric electrical activity since its electronic control system may be subject to damage/disruption by discharges and intense magnetic impulses. In addition to the usual sensitivity of a vertically launched, slowly accelerating vehicle to horizontal wind shears, the Shuttle is subject to the special problems returning to a landing site without power. This decision must be made several hours before the landing and is then a commitment.

RECOMMENDED ACTION:

Special services in forecasting must be made available for Shuttle launches/landings. These forecasts should be based on the most advanced observing, assimilation, analysis, forecasting, and communication techniques available. Mesoscale modeling research should be pursued as a future forecasting tool. Even though it is not presently usable operationally, modeling offers some hope of providing objective, quantitative forecasting in years to come.

RESPONSIBLE AGENCIES: NASA, USAF, NOAA

.....

COMMITTEE: SPECIAL OBSERVATIONS
CHAIRMAN: Gerald F. O'Brien

MEMBERS:

Don Beran
Al Cooper
Norm Crabill
Lou Duncan
Art Hansen
Jack Hinkelman
Jean Lee
Roger Reinking
Tim Wise
Andy Yates

ISSUE:

Data obtained from ASDAR/ACAR systems are valuable. They could be even more useful if obtained during aircraft ascent and descent, and if additional parameters (humidity) were added.

DISCUSSION:

Use of data from ASDAR/ACAR systems have proved valuable to both forecasters and aircraft operators. Additional benefits could be realized if reports could be obtained during landings and takeoffs. The addition of a fast response hydrometer to the instrument package would provide a measure of the moisture profile as well as the temperature and wind profiles. It could supplement the existing radiosonde network when used on takeoff and landing.

We must realize that these data are asynoptic and some effort must be made by model developers to incorporate them in forecast models.

RECOMMENDED ACTION:

1. Encourage aircraft operators to equip appropriate aircraft with ASDAR/ACAR systems
2. Incorporate a fast response hygistor for use on sensor packages
3. Collect data on aircraft ascent and descent
4. Conduct studies on how data can best be used asymmetrically
5. Urge early developers to coordinate efforts through a national focal point

RESPONSIBLE AGENCIES:

1. Airlines, NWS, FAA
2. Industry
3. Airlines, NWS
4. NWS, Academic Institutions
5. NWS

PRIORITY:

1. High
2. High
3. Medium
4. Medium
5. High

ISSUE:

Wind shear during approach and takeoff continues to be a serious problem for aircraft operators. Installation of terminal Doppler weather radar is not yet in the FAA's plans, and there is disagreement on deployment techniques. Limited nationwide coverage of airports by a fully deployed system and ground-to-air weather advisories limited by available communication channels point to a need for airborne detection systems, which do not yet exist.

DISCUSSION:

There have been a number of accidents caused by wind shear. The current Low-Level Wind Shear Alert System (LLWSAS) does not appear to be the ultimate answer, and efforts on development of an on-board Doppler system appear to be grinding to a halt because of lack of financial support. The FAA does not have an approved program for development of a terminal Doppler radar system. With respect to on-aircraft detection systems, most of the aviation groups indicated high interest in advance warning of wind shear conditions, providing the system can be reasonable in cost and lightweight. In particular, cargo carriers and military aviation would like to identify gust fronts as well as microburst/downburst activity prior to penetration. (Helicopters are especially vulnerable to 15 kn gust fronts). Passenger carriers pointed out that on-board detection systems were recommended by the 1983 NAS report, if hardware could be developed.

RECOMMENDED ACTION:

Support efforts to complete research on the terminal Doppler radar while continuing research on airborne detection systems, alternately, and implement operational systems at a reasonable cost.

RESPONSIBLE AGENCIES: FAA, NWS, DOD

PRIORITY: High

ISSUE:

As new and special observing systems evolve, appropriate algorithms are required to assure the user gets useful information, not just more data.

DISCUSSION:

A number of new and special observing systems are evolving; e.g., Doppler radar, ASDAR, ACAR, profilers. Each system is capable of providing large amounts of data for the user when many of the ultimate users do not have time in their operational environment to deal with large data streams from one or more sensors. High-speed processing using appropriate algorithms can translate these sensor data into usable products for the user. At another level, algorithms are required to integrate information from several observing systems in a manner that captures the best mix of information.

RECOMMENDED ACTION:

Encourage developers of new observing systems to take full advantage of today's computer power to provide high-level information for users.

RESPONSIBLE AGENCIES: NWS, FAA, Industry

PRIORITY: High

ISSUE:

Data available from the LLWSAS are too complicated for controller use.

DISCUSSION:

Current displays of LLWSAS data provide a data stream that is difficult to comprehend in critical shear situations when the controller is busiest because of the long stream of information provided.

RECOMMENDED ACTION:

An improved display or product for use by controller should be developed through algorithm development and testing.

RESPONSIBLE AGENCIES: FAA

PRIORITY: High

ISSUE:

Users are not always capable of obtaining maximum benefit from special observing equipment because they are not proficient in using the data it produces.

DISCUSSION:

When new observing systems, especially systems like Doppler radar that provide new data display techniques for wind shear and wind fields are deployed in the field, quite often users who could profit do not because of inadequate training, nonexistence of training material, or no established proficiency requirements. This could be corrected by encouraging private industry to establish and conduct user-oriented courses in the use of special observing systems. In cases where safety of aircraft could be involved, demonstration of skills for certification and follow-up proficiency checks should be required.

RECOMMENDED ACTION:

1. The government should establish standards governing the use of products and systems.
2. Encourage private industry to establish and conduct training courses in the use and interpretation of new special observing systems.
3. Require demonstrated skill in interpreting data from complex systems as part of the biannual flight review appropriate to the rating being reviewed.

RESPONSIBLE AGENCIES:

1. FAA
2. NWS, FAA, Industry
3. FAA

PRIORITY:

1. High
2. High
3. High

ISSUE:

There is dissatisfaction with the accuracy of icing reports and with interpretation of both forecasts and reports.

DISCUSSION:

Future improvements may be expected to arise from current revisions in our understanding of storm structures and from new observing systems such as radiometers for the detection of liquid water. Current problems stem from both lack of accuracy and problems with interpretation. Accuracy may be improved through research that combines new observing systems with experimental forecasting development. Problems with interpretation include the current aircraft-dependence of icing severity reports and the inconsistency between certification requirements and reporting conventions.

RECOMMENDED ACTION:

Support current efforts to review reporting conventions and certification requirements. Encourage new research into icing forecasting which could combine new sensors with improved knowledge of storm structures.

RESPONSIBLE AGENCIES: NWS, DOD

PRIORITY: High

ISSUE:

Reporting of runway conditions is inadequate.

DISCUSSION:

Various user groups recommended sensors to report on runway temperatures, breaking ability, and depth of water, snow and slush. This is important at both attended and unattended airports. It was reported that a sensor is in use at the Spirit of St. Louis Airport.

RECOMMENDED ACTION:

The FAA should sponsor research and development to measure runway temperature, breaking conditions, and depth of water, snow and slush.

RESPONSIBLE AGENCIES: FAA

PRIORITY: Medium

.....

COMMITTEE: AVIATION FORECAST MODELS

CHAIRMAN: Raymond J. Stralka

MEMBERS:

- Fernando Caracena
- Des Desmarais
- Colin Flood
- John Garthner
- Bill Jaspersen
- John Keller
- Bob Miller
- Bill Rogers
- Jan Tissot

ISSUE:

Modeling for usable icing parameters is recommended.

DISCUSSION:

Present information is too vague and not airframe dependent (1950 technology).

Model output should include the variables required to enter icing curves provided by the aircraft manufacturer for example:

- a) liquid water content
- b) type of cloud (stratus, cumulus)
- c) vertical extent of cloud-temperature below freezing
- d) vertical velocity
- e) area extent
- f) age of the cloud system

Present models are not capable of depicting freezing rain. Plans are being formed by the Aviation Weather Task Force to define the icing problem.

RECOMMENDED ACTION:

Advocate continuation of efforts to develop specifications pertaining to aircraft icing.

Encourage the modelers at NMC, British Meteorological Office, USN and USAF to provide the required parameters.

Encourage industry to develop frames of reference for icing on various airframes in use today and proposed for the future.

RESPONSIBLE AGENCIES: NMC, DOD, Aircraft Industry, British Met. Office

PRIORITY: High

ISSUE:

Terminal Forecasts:

1. There is a decreasing number of operating hours at various terminals
2. Manmade FT's often do not adequately take into account the effects of local conditions.
3. Failure rate of automated systems when they become widespread is of concern.

DISCUSSION:

The hours during which airport FT's are available are decreasing. This is a particular problem for night flyers such as the cargo airlines. The problem can be remedied by using models such as GEM (see page 133). This model is airport and time independent. GEM has already been shown to provide better forecasts than persistence (current on-going forecasts) and the predominant conditions of the manmade FT's inside 3 hours. GEM is currently under development and testing to predict from the automated observations (AWOS, ASOS). The output of hourly GEM can be produced on a microcomputer and is able to operate using special or record observations. Reliability of automated observation systems such as AWOS has been found to be fairly high.

RECOMMENDED ACTION:

Implement

RESPONSIBLE AGENCIES: NWS, FAA

PRIORITY: High

ISSUE:

There is a need to improve the accuracy and timeliness of all numerical weather prediction products for aviation.

DISCUSSION:

In spite of the expected improvements in NMC model forecasts this year, as presented by Charles Sprinkle of NWS, (see page 139) and the current skill of forecasts available from the British Meteorological Office in Bracknell, most floating committees expressed requirements for further improvements in forecasting winds and temperatures aloft. Temperature forecasts around 50,000 ft. (100 mb) were of special concern, but the requirement for 1°C accuracy is not currently available.

To improve operational models, there is a need to increase the observational data base; especially aircraft reports. Improve sharing of meteorological information; i.e., PIREPs, etc. Better communications are also required to improve the timeliness of forecast products.

RECOMMENDED ACTION:

Further development of operational NWS products is needed. There is a need to develop indicators for in-flight hazardous weather phenomena, increase quantity of aircraft reports and introduce new observing systems, e.g., profiler, radar, etc.

RESPONSIBLE AGENCIES: NWS, NMC, ATA, Airlines, ARINC, ICAO, FAA, British Met. Office (Bracknell)

PRIORITY: Medium

ISSUE:

A need was identified for generating microburst and wind shear predictions. Predictions would supplement other now-casting systems that have been proposed. Although microbursts are of very small temporal and spatial scales, they can perhaps be predicted on the basis of larger scale meteorological fields as potential hazards rather than pinpointing for specific terminals.

DISCUSSION:

Three types of microbursts have been identified:

1. The dry microburst which descends in a virga shaft from a high-based cumulonimbus;

2. The wet (or water-loaded) type which affects humid regions;
3. The dynamically driven type of severe storm.

Presently, as a result of project JAWS, only the dry microburst type is sufficiently understood to be predicted from model output statistics. Further research is needed to arrive at a generalized, microburst predictive scheme. Project MIST, which was performed in the Huntsville, Alabama area in 1986, provided much needed data on the wet microburst type.

RECOMMENDED ACTION:

Project MIST data could be used to possibly generate a wet microburst predictive technique. The NOAA National Severe Storms Laboratory (NOAA/NSSL) might have sufficient data on dynamically-driven microbursts to do likewise.

RESPONSIBLE AGENCIES: NSF, University of Chicago (Fujita), NOAA-NSSL, NASA, UTSI.

PRIORITY: Medium

ISSUE:

Better CAT detection and forecasting are needed.

DISCUSSION:

A need for better resolution of upper-level fronts and winds was discussed. This was in the context of producing better clear-air turbulence (CAT) forecasts. Many airlines have reduced, and some even eliminated, their meteorology sections. Hence, a way for screening areas of CAT risk is needed to help fill this gap. It is expected that the new 18-level spectral aviation model at NMC should greatly help alleviate the resolution problem, particularly near the tropopause.

The aviation task force was discussed relative to its study of turbulence forecasting techniques, such as the SCATR index. The possibility of using spectral model output to calculate SCATR index fields was considered.

RECOMMENDED ACTION:

Further validation and verification of the SCATR index technique is needed as part of the MIST/SPACE field study (spring 1986).

RESPONSIBLE AGENCIES: NASA, NOAA, NSF

PRIORITY: Medium

COMMITTEE: USING THE SYSTEM

CHAIRMAN: John R. Gallimore

MEMBERS:

John Blasic
Herb Brody
Malcolm Burgess
Myron Clark
Dick Gramzow
Bud Laynor
Doug Lundgren
Bob Skonezny

ISSUE:

There is a need to develop new automated systems to disseminate weather data and process flight data for pilots.

DISCUSSION:

- DUATS - Direct User Access Terminal Systems
- IVRS - Interim Voice Response Systems
- FSAS - Flight Service Automation Systems
- Government versus commercially provided weather services
- Standardization and quality control of provided weather products
- Access to a national data base system
- Needs of the users: a) flight plan optimization; b) graphics versus alphanumeric; c) satellite data; and d) expert interpretation and simplification of meteorological data for general aviation

RECOMMENDED ACTION:

Implementation of a national system to off-load the flight service automation system providing a toll-free service system to all pilots.

RESPONSIBLE AGENCIES: FAA

PRIORITY: High

ISSUE:

Workshop representatives of all segments of communities that government agencies and industrial organizations request the need for a report within one year, or the progress made on programs discussed at this year's workshop as well as all previous workshops.

DISCUSSION:

The following items were discussed as carryovers from previous workshops:

- Research, reporting, forecasting and warnings of icing conditions
- Nationwide implementation of a voice response weather briefing system
- Reformatting and expansion of weather messages
- The accessibility of all meteorological data bases
- Common understandable formats for weather inputs of data
- Establish methods of collection and dissemination of PIREPs by air traffic controllers to forecasting agencies
- Terminal Doppler radar design
- The NEXRAD and Mode-S Systems

RECOMMENDED ACTION:

Review previous recommendations and establish the status of research and development projects and services. Compare and review the implementation schedule priorities before the Ninth Annual Workshop session.

RESPONSIBLE AGENCIES: Under the direction of the Annual Workshop Organization Committee

PRIORITY: High

ISSUE:

There is a need to surface key issues to improve pilot weather education and expand a positive action program to provide weather education requirements for flight instructors.

DISCUSSION:

- Weather education and recurrent weather training requirements for general aviation pilots
- Require additional training and provide new regulations for flight instructors

- Provide public relations and marketing services to pilot communities when new systems are implemented for public use
- Publicize changes to airspace design, documentation, regulation and procedures
- Provide yearly updates of manuals, e.g., AC-45
- A need exists to train and educate pilots on how to use and interpret weather information

RECOMMENDED ACTION:

Provide a communications media to provide changes, additions and updates of weather and flight data information within the National Airspace System.

PRIORITY: Medium

ISSUE:

The needs and desires of each pilot group should be considered to better the dissemination of weather data and to share in the collected weather information.

DISCUSSION:

- General Aviation - A need exists to provide adequate preflight weather briefings for the broad experience levels of general aviation pilots.
- Cargo Airlines - A need exists to provide current weather observations and dissemination of significant weather during nighttime operations and the dissemination of PIREPs.
- Corporate Aviation - A need exists to consolidate and interpret weather data. The question asked was, "Who should be responsible for flight optimization?"
- Passenger Airlines - A need exists to develop a better grid system to define areas of coverage for hazardous weather, and to change conservative forecasting, e.g., SIGMETs.
- Military Aviation - A need exists to improve forecasting of icing and turbulence conditions and real-time communication of microburst detection observations.

PRIORITY: Medium

.....

COMMITTEE: PASSENGER AIRLINES
CHAIRMAN: Russell Crawford

MEMBERS:

Ho-Pen Chang
Tom Genz
Dale Istwan
John Klehr
Leroy Lockwood
Jim Luers
Geoff Molloy
John Rankin
Bill Reiners
Jim Sullivan
Rod Wingrove

ISSUE:

What is the status of the profiler program?

DISCUSSION:

There was some concern that the profiler program had run into some technical problems with frequency ranges and limited temperature sensing capabilities that could drag out or stop the profiler program. The committee understands that these problems are being resolved and the program is moving forward. It is believed that the profiler is a logical supplement to, if not a replacement for, the rawinsonde.

RECOMMENDED ACTION:

Support the implementation of the profiler network.

RESPONSIBLE AGENCIES: NWS, NOAA

PRIORITY: High

ISSUE:

Will the quality of the surface observation be degraded by automation?

DISCUSSION:

There are three concerns regarding AWOS:

- 1) Accuracy of the "subjective" values (e.g., cloud coverage or type of visibility obstruction)

2) Source of remarks (e.g., "fog bank to the west" or "frequent lightning to the southeast")

3) Reliability.

The current proposal calls for the observer remaining in the loop to supplement and oversee the system. If the observer is removed from the loop without further improving the system, the output from the automated system would not be as good as the present product. This degradation would adversely affect airline safety.

RECOMMENDED ACTION:

Keep the observer in the loop until technology permits full automation without degradation of the product.

RESPONSIBLE AGENCIES: NWS, FAA

PRIORITY: High

ISSUE:

What has been the status of the NEXRAD Program?

DISCUSSION:

The NEXRAD Program was on schedule with testing in 1986 and full implementation planned by 1992. This program has been strongly supported in the past workshops and this committee endorses that support.

RECOMMENDED ACTION:

Continue strong support of the implementation of the NEXRAD Doppler system.

RESPONSIBLE AGENCIES: NWS, FAA, DOD

PRIORITY: High

ISSUE:

What is the status of the terminal Doppler radar?

DISCUSSION:

This program is currently on hold. This system appears to have a great deal of

potential in locating and quantifying low-level wind shear. Questions regarding the cost effectiveness and capabilities have caused the hold on the program. There is hope that a test program will be funded in 1987. The committee feels this system is a viable tool and should be evaluated.

RECOMMENDED ACTION:

Strongly support the reactivation of the terminal Doppler test program.

RESPONSIBLE AGENCIES: NWS, FAA, DOD

PRIORITY: High

ISSUE:

What is the status of the changes to the computer models at NMC?

DISCUSSION:

The recently installed Cyber 205 computer has provided NMC with the opportunity to upgrade the aviation forecast products. These enhancements will improve the accuracy of flight plans, thereby improving the safety and economics of the flight.

The need for better forecasts has been discussed for some time and the upgrades are most welcome.

RECOMMENDED ACTION:

Support the efforts of NMC.

RESPONSIBLE AGENCIES: NMC

PRIORITY: High

ISSUE:

Consider the issue of relaying weather data to the user.

The emphasis on new meteorological tools has been, and still is, on producing the data. Less consideration is given to how the consumer is going to use the data and how the data are going to be relayed to the consumer. New products, as well as existing products, need to be considered as part of a concerted program designed to give the user what he needs when he needs it.

RECOMMENDED ACTION:

Set up a task force or committee to develop a meteorological data user program and a means to update the program as new projects are implemented.

RESPONSIBLE AGENCIES: FAA, NWS, Users

PRIORITY: High

ISSUE:

Emphasize the importance of continuing projects once the project is justified and approved.

DISCUSSION:

All too often an approved project is interrupted due to funding. We wonder if there is not a better means of assuring a justified project will, in fact, be completed. The House of Representatives Subcommittee on Investigations and Oversight has charged the FAA and the NWS to stop studying and start acting on research and development projects.

Although this committee endorses this recommendation, we recognize there are two distinct types of projects, those which are research and, therefore, open-ended, and those which are essentially developmental and address a particular need within a specific time scale.

RECOMMENDED ACTION:

Urge the NWS and FAA to take advantage of the opportunity afforded by the Subcommittee's charge to review their procedures.

RESPONSIBLE AGENCIES: NWS, FAA

PRIORITY: High

.....

COMMITTEE: CARGO AIRLINES

CHAIRMAN: William H. Pickron

MEMBERS:

Stan Aoyagi

Bill Day

Jim McLean

Porter Perkins
Bob Reich
Mike Tomlinson
Bob Turner

ISSUE:

Weather support to cargo carrier operations, especially night IFR operations.

DISCUSSION:

CWSU's provide an added value to area forecasts, AIRMETs and SIGMETs. This service is not available overnight (i.e., for 1/3 of the day). The vast majority of air cargo operations are conducted during this period.

CWSU's would also make it possible to increase the number of pilot reports solicited and processed into the system. Current AIRMETs and SIGMETs encompass larger areas and longer time periods than CWSU products. This may result in unnecessary constraints to air cargo operations.

RECOMMENDED ACTION:

Expand CWSU and CFWSU operations to cover the overnight period.

RESPONSIBLE AGENCIES: NWS, FAA

PRIORITY: High

ISSUE:

Maintain the access to flight planning and weather data that is available with the present flight service stations.

DISCUSSION:

Cargo carriers have crucial data access needs that are affected by reduction in FSS outlets. DUAT and VRS alternatives were reviewed as possible acceptable options. The cost versus service limitations on third-level options was also discussed.

RECOMMENDED ACTION:

Assure that access to comparable meteorological and flight planning data, at low or no additional cost to the user, is available as the FSS automation program progresses.

RESPONSIBLE AGENCIES: FAA, NWS

PRIORITY: High

ISSUE:

Disseminate data of PIREPs (winds aloft, temperatures at altitude, etc.)

DISCUSSION:

Many PIREPs are not disseminated beyond the air carrier originating the report, and consequently do not get into the NWS forecast model where they could improve the forecast. The quality of such INS winds and static air temperature is such that their inclusion to the model is extremely valuable.

In order to get this information to the appropriate agencies, there must be cost benefits to that airline because the present contract communications companies charge the air carrier to transmit this data to NWS. Since this information has already served the airline in its own forecast modeling, there is no incentive to incur the additional cost.

A standardized format for PIREPs must be defined and accepted by all parties involved if this system is to work.

RECOMMENDED ACTION:

ATA, NWS, FAA must make an effort to establish a system which is acceptable to all concerned from a liability and cost standpoint.

RESPONSIBLE AGENCIES: ATA, NWS, FAA

PRIORITY: High

ISSUE:

AWOS implementation for the third-level cargo carrier (small, single-/multi-engine aircraft flying supplemental night cargo).

DISCUSSION:

It is imperative that certain conditions are placed on this system's implementation since the aforementioned carrier operations are into small airports with minimal or no observer capabilities. Most of these operations have no in-house meteorology capabilities and rely totally on FSS.

The implementation of AWOS should

- Be directed first to those airports having no other means of weather observation
- Be preceded by sufficient testing to assure that its measurements are as accurate as present observer systems with respect to winds, barometer data, ceilings and visibility
- Be complimented by an education process that informs the user community of any dispatch between AWOS observations and present reported data
- Once activated at a particular airport, should be available at all times to the pilot through discrete frequency access
- Have a failure mode protection capability that allows for local data extrapolation in the event of system site failure (fault identification broadcast)
- Be coupled with a system such as a DUAT (Direct User Access Terminal) which would be required to provide an equivalent coverage/service to this level of cargo operations that is presently supplied by the current FSS system

RESPONSIBLE AGENCIES: NWS, FAA

PRIORITY: Medium

.....

COMMITTEE: CORPORATE AVIATION
CHAIRMAN: Richard J. Van Gemert

MEMBERS:

- Neil Allen
- Leo Boyd
- Kao-Huah Huang
- Bob Kendall
- John Prodan

ISSUE:

Establish a driving force for workshop recommendation implementation.

DISCUSSION:

In this day and age of reduced budgets for both dollars and manpower and increased competition for the same, it is essential that the end users in the aviation systems strongly support the implementation of the workshop recommendations.

During the past seven workshops, many issues have been discussed and recommendations have been made regarding actions to be taken by various governmental agencies. Many studies, research activities, and development programs have been initiated as a result. A large number of those issues and recommendations have been discussed again and agreed to at this eighth workshop by essentially new participants.

Very often, during these interactive discussions, the comment was made by the government technical people that they lacked the strength and resources to be the advocates for the implementation of the workshop recommendations. We believe that the end users in the aviation systems should integrate these recommendations into their agendas and proceed with the political process of establishing the public need for the products and services recommended. A coordinated approach by such responsible organizations as ALPA, AOPA, ATA, GAMA, NBAA, HAA, FSF and RAA would go far in establishing the public need and could provide the impetus for timely implementation of the workshop recommendations.

RECOMMENDED ACTION:

An editorial committee composed of the fixed and floating committee chairpersons should be established immediately to produce an executive summary of the recommendations of all of the workshops—one through eight. This summary should then be sent to the aviation system user organizations (as above) for integration into their agendas.

RESPONSIBLE AGENCIES: Workshop Organization Committee and Committee Chairpersons

PRIORITY: Highest Possible

ISSUE:

Develop a system which can integrate the existing weather information, provide a service to do the analysis, and forecast and transfer the consolidated results to the user.

DISCUSSION:

- The existing data base provides the entire aviation community with quality raw data; however, the small corporate aviation department is not able to interpret these data, and Flight Service Stations have to be depended upon.
- The shortcomings created by closed or reduced hours FAA and NWS facilities must be overcome.

- Three to four hours of forecast accuracy is required in order to let pilots plan the flight within the last 30 minutes before takeoff.
- Existing weather service network systems still do not cover most areas where corporate aviation has an interest, owing to the cost of equipment.
- An ideal weather service system should be easy to access, provide the optimized flight plan, and provide consolidated results to help the pilot in decision-making.
- An ideal weather service system enhances cockpit access to weather information, including updated terminal weather conditions, i.e., wind shear alert and warning, icing conditions, and temperature variations.

RECOMMENDED ACTION:

Our recommendation is twofold. Either move to allow greater access of the data bases to the private sector for consolidated processing and distribution, or gain some synergistic benefit through FSS consolidation of forecast data to provide greater skill levels for analysis and distribution.

RESPONSIBLE AGENCIES: FAA, NWS

PRIORITY: High

ISSUE:

AWOS implementation at remote and unmanned IFR airports is long overdue. AWOS is essential for safe and efficient operation for both ATC and NWS observations and forecasting.

DISCUSSION:

AWOS can be enhanced by adding several features:

- 1) Satellite interrogation can add AWOS sensors into the meteorological network for enhanced area and frontal weather activity information. Temperature should be transmitted as accurately as possible to develop more useful trend data.
- 2) Include ATC two-way communications at remote AWOS sites. This can enhance IFR efficiency, number of aircraft serviced, and operational safety.
- 3) Include remote-controlled TV camera (controllable by ATC area controller, NWS personnel, etc.) for observing airport precipitation, general visibility and runway conditions for snow cover, etc..

4) Include AWOS at controlled/manned airports and accessed by satellite up/down link. This will permit direct NWS computer access.

Digital computers need real-time precise data. Declining weather conditions can be monitored and data updated every five months, if needed, adding potentially a quantum jump in weather data quality—both in nowcasts and forecasts.

RECOMMENDED ACTION:

Implement satellite up/downlinked AWOS stations at all IFR airports. Twenty percent of all IFR airports should have installation completed and operational each year beginning in 1987.

RESPONSIBLE AGENCIES: FAA and NWS, jointly. (Funding: Aviation Trust Fund)

PRIORITY: High

ISSUE:

Implement runway surface covering detection system as an integral part of an automated surface observation and reporting system.

DISCUSSION:

Many operators (corporate, general, commuter, and, in some cases, air carrier) may conduct operations at uncontrolled airports. These airports may be entirely uncontrolled or may conduct limited control operations during certain hours of the day or night. At such airports, a need exists to sense runway surface coating conditions. In conjunction with surface or terminal area weather conditions, a runway surface coating has a serious impact on aircraft performance during either a takeoff or landing. Acceleration is impeded, and stopping distances become marginal under such runway conditions. A runway surface coating coupled with a high crosswind condition may seriously impact safe aircraft operations. Therefore, such runway coating conditions must be properly and accurately recorded, reported, and evaluated coincidentally with the automatic surface or weather observation systems recording and reporting weather conditions at such airports.

RECOMMENDED ACTION:

Develop an accurate, automatic, and full-time runway surface monitoring capability to include the reporting of type and depth of the coating and the runway temperature.

RESPONSIBLE AGENCIES: FAA

PRIORITY: High

.....

COMMITTEE: GENERAL AVIATION

CHAIRMAN: Elaine McCoy

MEMBERS:

- Ralph Pass
- Erik Ringnes
- Bernard Shanahan
- Joe Stickle
- Frank Wencel

ISSUE:

The status of weather education requirements for general aviation pilots.

DISCUSSION:

General aviation fatalities are often the result of weather-related accidents. Current testing procedures are inadequate for establishing pilot competency with regard to weather criteria, and weather theory study is in need of reinforcement. For example, written exams currently permit an applicant to pass the exam even if missing all weather-related items, while the BFR, a key opportunity for competency checks in all areas, fails to incorporate weather review by regulation. Additionally, updates of aviation weather and aviation weather service bulletins are needed. In addition to weather knowledge, weather-related pilot judgment skills need to be enhanced through textual-situational judgment training to further compound the problem of weather education. The influx of new services (including automated self-briefing to the general aviation community) is occurring without plans at the national level for a familiarization or educational program covering these options. Inactive or low-time pilots may not know the available options or the diversity of formats appearing in the private and government sectors.

RECOMMENDED ACTION:

- Require demonstrated meteorological knowledge at written, oral, and practical test levels for obtaining airmen certificates.
- Require the BFR to incorporate demonstrated weather competency.
- Encourage flight instructors to emphasize the importance of weather theory through certification procedures and flight refresher clinics.

- Incorporate weather judgment training in flight training.
- Utilize accident prevention seminars to assist pilots in using all services available for preflight briefing.
- In letters to airmen, indicate specific facility improvements as well as national improvements (Aviation Services Branch).
- Update aviation weather services.

RESPONSIBLE AGENCIES: FAA, NWS, NTSB, Air Safety Foundation, AOPA, educational institutions, flight schools, etc.

PRIORITY: Highest Possible

ISSUE:

Does Mode-S satisfy general aviation requirements for an airborne data link?

DISCUSSION:

Mode-S specifications under consideration were derived about ten years ago and contain levels of error unacceptable by current standards. It is insufficient for low-altitude and oceanic use in that projected altitude restrictions are impractical for general aviation aircraft, i.e., a floor of 12,500 ft. by 1995 and 6000 ft. by the year 2000.

The data stream is restricted by the mode of operation. Each aircraft must be discreetly addressed and can be sent data only during the time the antenna sweep hits the aircraft. Transmission rate is limited and insufficient graphics would result. The Mode-S is unnecessarily tied to the ATC ground-based surveillance function and is not compatible with projected satellite systems.

An equipment purchase, such as Mode-S, would constitute a major investment for the General Aviation community; therefore, such a required investment needs to be carefully examined.

RECOMMENDED ACTION:

Separate tie of ATC surveillance and traffic control from weather data transmission function. Explore compatible alternate satellite options.

RESPONSIBLE AGENCIES: FAA, NWS

PRIORITY: High

ISSUE:

Dissemination of automated information is needed.

DISCUSSION:

General aviation needs to maximize its use of automated information both in flight planning and in airborne operations. Data appears in various formats from many sources including AWOS, ASOS, radar, satellites, and lightning detection systems. Data that may be safely and efficiently utilized on the ground may differ from data desired in-flight. Weather information from unmanned airports is critical to the general aviation pilot. Many airports with instrument approaches may not qualify for full AWOS capability, but minimal information including field altimeter setting is needed.

RECOMMENDED ACTION:

Preflight data

- Standardize format.
- Provide in readily-assimilated, readable graphic form.
- Increase frequency of forecasts integrating sources such as satellite, radar, lightning.
- Provide accessibility to human briefer.
- Provide for manual augmentation of reports.

Airborne data

- Satisfy general aviation needs to receive data link that provides low-altitude down-to-surface coverage and selective access to better graphics
- Pursue satellite options.

Install at unmanned airports with instrument approaches partial parameter AWOS sensors including altimeter, wind, temperature/dewpoint information.

RESPONSIBLE AGENCIES: FAA, NWS

PRIORITY: High

ISSUE:

Weather information systems must reflect user requirements.

DISCUSSION:

Technological capability to produce varying quantities and qualities of data needs to be controlled by user requirements. User requirements may, in fact, represent lower cost operation than state-of-the-art procedures. The generation of data

inappropriate to the needs of the population can be preceded by establishing an interactive process involving users in the development of the systems.

RECOMMENDED ACTION:

Define user requirements, evaluate alternatives. Refine process and test the system by incorporating a sampling of the users, e.g., the profiler, terminal Doppler radar, Mode-S, etc.

RESPONSIBLE AGENCIES: FAA, NWS

PRIORITY: High

ISSUE:

Improve observations of unmeasured phenomena.

DISCUSSION:

Problems of continuing concern for general aviation are forecasting of icing conditions, cloud layers, and turbulence. The best current source of such information is the PIREP. Initial research indicates the use of radiometry to be effective in predicting icing and aids in identification of cloud layers, and, therefore, possible associated turbulence. More parameters need to be developed for these conditions. Pilots concerned with en route wind shear and turbulence associated with CAT, frontal passage, and terminal problems with microbursts or frontal passages might benefit from ground-based radar uplink. Four-dimensional data base may assist in thunderstorm location. Cloud tops also need to be identified.

RECOMMENDED ACTION:

Pursue an operational program to further test the effectiveness of radiometry in identification of icing zones. Investigate correlated use of NEXRAD, profiler, and radiometry.

.....

COMMITTEE: MILITARY AVIATION
CHAIRMAN: Lt. Col. James L. Crook

MEMBERS:
Bob Dean
John Houbolt
Bob Korose

Dave Lueck
Mike McLane
John Theon
Joe Towers
Ken Wantzloeben
Gary Worley

ISSUE:

Meteorological data and forecast support should be available to aid military operations below 5000 ft.

DISCUSSION:

Military aviators are most vulnerable to hazardous weather conditions when operating below 5000 ft. Typical Army operating tactics involve high-speed helicopter operations below treetop-level. Air Force and Navy tactics for weapon delivery and close air support also rely on low-altitude high-speed flights. In many instances, these flights are made in adverse weather conditions; i.e., turbulence, restricted visibilities, low clouds, precipitation and icing. Currently, observations and forecasts for this boundary layer (sfc-5000 ft.) are not adequate. Additionally, the physical processes occurring at these low levels are not always adequately understood. Increased modeling efforts at high levels, i.e., 500 mb and above, as well as limited automated surface observations at major airports will not always address this issue. The technology exists to define the boundary layer but is not being applied to these support requirements.

RECOMMENDED ACTION:

Make low-level data which is currently available at forecast centers available to field forecasters and aircrews.

Mesoscale modeling and advanced research must focus on the problems within the boundary layers, especially terrain and atmospheric interactions.

RESPONSIBLE AGENCIES: FAA, NOAA, DOD

PRIORITY: High (Short-range)

ISSUE:

Continue development of terminal and airborne Doppler radar systems for detection of microbursts and other hazardous wind shear phenomena.

DISCUSSION:

Doppler radars have been successful in detecting microbursts and hazardous low-altitude wind shear. Although NEXRAD will provide a significant input to severe weather analysis and forecasting, its 5-minute data collection scan significantly limits its capability for observing short-term, small-scale phenomena such as microbursts. Therefore, an observing system must be developed specifically for terminal area detection of the extremely hazardous weather phenomena. In addition, research should continue toward development of an airborne system that will provide real-time advanced warning of hazardous shear conditions.

RECOMMENDED ACTION:

Continue research and development of airborne and terminal wind shear observation and warning systems.

RESPONSIBLE AGENCIES: NOAA, NASA, FAA

PRIORITY: High (Short-range)

ISSUE:

New data-gathering systems and forecast techniques are needed to provide innovative approaches to improved predictions of airframe icing for specific aircraft and not necessarily generic-type aircraft.

DISCUSSION:

There has been no significant increase for the past 30 years in the ability of the weather services and interested government agencies to accurately forecast airframe icing for military aircraft. Data and forecast techniques used today to predict airframe icing were collected and are issued in broad terms. For example, a forecast might be issued for a specific geographical area and altitude without regard to aircraft type. Anyone in the business knows this is not valid. What is potential icing for an A-10 is insignificant for a C-5. There is a need to develop a set of performance curves that could be published in a specific aircraft's flight manual that indicates the severity of icing for an observed or predicted set of weather parameters (temperatures, cloud type, liquid water content, drop size, etc.) These curves will have been derived by an aerodynamicist using a computer program which contains all the essential elements for that particular aircraft to include the radius of curvature of the airfoil, airspeed, angle of attack, and planned maneuver. This technique could be applied to all aircraft in the inventory.

RECOMMENDED ACTION:

While we fully support the National Icing Program Plan, we believe this issue should be coordinated with the government's lead agency for airframe icing.

RESPONSIBLE AGENCIES: NOAA, FAA, NASA, DOD

PRIORITY: High (Short-range)

ISSUE:

There is a need for preflight weather dissemination.

DISCUSSION:

There is a need to expand the availability of weather information to users of the system. Budget cuts in the FSS and Air Weather Service areas have resulted in shortages of qualified personnel available to provide tailored aircrew weather briefings. There is a need to provide better access and methods to obtain up-to-date weather information.

RECOMMENDED ACTION:

Develop interactive systems/processes for obtaining increased access to weather information services.

RESPONSIBLE AGENCIES: NOAA, FAA, DOD

PRIORITY: High (Short-range)

ISSUE:

Information dissemination is needed to provide rapid, concise transfer of hazardous weather information in real time to the aircrew without over saturation in task intensive situations.

DISCUSSION:

As more and more information on changing weather situations becomes available, there is a need to process and transmit this complex data in a way that insures rapid pilot assimilation. The question becomes, "When does additional information over saturate the pilot's workload capability?" This is particularly true during critical phases of flight, e.g., takeoff, departure, approach and landing, when the information is most valuable.

RECOMMENDED ACTION:

Develop methods and means to transmit essential, key weather information to the pilot that can be rapidly assimilated during task saturated situations.

RESPONSIBLE AGENCIES: FAA, NWS

PRIORITY: High (Long-range)

ISSUE:

Angle-of-attack indicators and inertially driven vertical speed indicators need to be installed for future generation military aircraft.

DISCUSSION:

This type of flight instrumentation will greatly enhance the aircrew's ability to confidently maneuver the aircraft to extract greater aerodynamic performance. This is especially important when aircraft flight path direction is affected by hazardous meteorological phenomena (e.g., low-level wind shear, turbulence, and microbursts).

RECOMMENDED ACTION:

Implement aircraft with angle-of-attack indicators and inertially driven speed indicators.

RESPONSIBLE AGENCIES: FAA, DOD

PRIORITY: High (Long-range)

ISSUE:

There is a military need for in-flight detection turbulence potential, at normal cruise altitudes as well as in low-level flight operations.

DISCUSSION:

High-performance military aircraft and helicopters are not exempt from the hazards of clear-air turbulence. In fact, military missions, such as in-flight refueling and terrain following flight at all speeds, require maximum aerodynamic performance of aircraft and cruise missiles.

Simultaneously, there is presently considerable emphasis on the potential hazards of wind shear in the airport vicinity. Remote detection and in-flight warning or control (e.g., cruise missile, Space Shuttle) is needed for mission success and safety of flight.

RECOMMENDED ACTION:

Cooperative efforts are needed in turbulence research and instrumentation development which will simultaneously satisfy military and civilian objectives.

RESPONSIBLE AGENCIES: DOD, NASA, FAA, NOAA

PRIORITY: High (Ongoing).

SECTION VII
CONCLUDING REMARKS

CONCLUDING REMARKS

Dr. Walter Frost

I have been very pleased at this workshop to hear recommendations which are somewhat unique, at least to me. Through several years of participating in these workshops, I have heard recommendations being repeated; but this year I have heard many innovative ideas coming from the committee sessions. I believe the chairmen have done an excellent job of summarizing and presenting their work, and I would like to thank them. Of course, we also realize that the chairmen could not do their jobs if everyone else were not here to help them. We appreciate your coming out and working the problems. We are going to be working in the future with Manny Ballenzweig through the Office of the Federal Coordinator on the Ninth Annual Workshop, and we will try to work through the Organization Committee to try to get these recommendations into the system. Before I close, I would like to ask our Organization Committee Representatives to give their closing comments. I would like to ask Manny Ballenzweig to come up first.

Emanuel Ballenzweig, OFCM

I want to thank you, Walt, for your help in organizing this meeting and making it as successful as it is. Through your hard work and example, you have made workaholics out of many of these people, and that has been good. I would like to thank all of you for your participation. These workshops depend upon you. I appreciate the recommendations you have given for improving the workshops of the future. As Walt has indicated, we will take them under consideration. Many of you have said that one value of these workshops is the interaction we all experience. But getting these issues and recommendations to you is also important. I want to thank you all again. I would also like to thank Linda Hershman for all of her help, and UTSI for providing these excellent facilities for holding this meeting.

Charles Sprinkle, NWS

First of all, I would like to thank everyone for working so hard. I know the hours are long here. Some of you who have come here for the first time may have thought the workshop was always a piece of cake; however, now you have seen the long hours which are put in. I think we are coming to a critical point in our workshops. This is the eighth one, and I am extremely interested in everyone's comments. Most of you will leave here and think no more about it until you get a letter from Walt in another year. I would appreciate each of you giving it a little thought. If you have suggestions as to how to improve the workshop the good points and/or bad points—we would really like to hear from you. If I may impose upon Manny Ballenzweig to be the focal point for those comments, we would appreciate

your sending these to him with a copy to Walt. We have held six workshops on an annual basis and two at 18-month intervals. Some people say they hear the same issues being raised, and there are things we can do to improve this; but we would like to have your ideas to make this workshop even better than it is. It was good to see so many new faces this year because your ideas are refreshing. I would also like to thank our colleagues from Canada, Australia, and the United Kingdom for taking the time to join us and share your expertise with us. Thank you for coming back to the colony and have a safe trip home.

APPENDICES

APPENDIX A
LIST OF ACRONYMS

ACAR	ARINC Communications Addressing and Reporting System	AMOS	Automated Meteorological Observing System
ACT	Actual Observations	ANGB	Air National Guard Base
ADI	Attitude Display Indicator	AOPA	Aircraft Owners and Pilots Association
ADAP	Airport Development Aid Program	APU	Auxiliary Power Unit
ADP	Advanced Development Program	ARF	Aviation Route Forecast
AEDC	Arnold Engineering Development Center	ARINC	Aeronautical Radio Incorporated Communications System
AEH	Atmospheric Electricity Hazards	ARSR	Air Route Surveillance Radar
AEHP	Atmospheric Electricity Hazards Protection	ARTCC	Air Route Traffic Control Center
AFFDL	Air Force Flight Dynamics Laboratory	ASD	Aeronautical Systems Division
AFB	Air Force Base	ASDAR	Aircraft/Satellite Data Relay
AFGL	Air Force Geophysical Laboratory	ASI	Atmospheric Science Laboratory, Airspeed Indicator
AFOS	Automation of Field Operations and Services	ASOS	Aviation Surface Observation System
AFTN	Aeronautical Fixed Telecommunications Network	ASR	Airport Surveillance Radar
AFWAL	Air Force Wright Patterson Aeronautical Laboratories	ATA	Air Transport Association
AGL	Above Ground Level	ATC	Air Traffic Control
AIM	Airmen's Information Manual	ATIS	Automatic Terminal Information Service
AIRMET	Airman's Meteorological Information	AV-AWOS	Aviation Automated Weather Observation System
ALPA	Air Line Pilots Association	AVRADCOM	Army Aviation Research and Development Command
ALWOS	Automatic Low-cost Weather Observing System	AWDS	Automated Weather Distribution System
AMDAR	Aircraft Meteorological Data Relay	AWIPS-90	Advanced Weather Interactive Processing System of the 1990's

AWOS	Automated Weather Observation System	CRT	Cathode Ray Tube
AWP	Aviation Weather Processor	CSIS	Centralized Storm Information System
AWS	Air Weather Service	CSU	Colorado State University
AZRAN	Azimuth and Range	CW	Continuous Wave
BA	British Airways	CWA	Center Weather Advisory
BFG	B. F. Goodrich	CWDS	Cockpit Weather Display System
BFR	Biennial Flight Review	CWP	Center Weather Processor
BLM	Bureau of Land Management	CWSU	Center Weather Service Unit
BSM	Back-Scatter Meter	DABS	Discrete Address Beacon System
CAT	Clear Air Turbulence	DABS DL	Discrete Address Beacon System Data Link
CCOPE	Cooperative Convective Precipitation Experiment	DBV	Diagonal Breaking Vehicle
CD	Common Digitizer	DEN	Denver
CDC	Control Data Corporation	DC	Direct Current
CDI	Course Direction Indicator	DFC	Distinguished Flying Cross
CFCF	Central Flow Control Facility	DMSP	Defense Meteorological Satellite Program
CFWSU	Central Flow Weather Service Unit	DNA	Defense Nuclear Agency
CG ATIS	Computer Generated Automatic Terminal Information Service	DOC	Department of Commerce
CGI	Computer Generated Imagery	DOD	Department of Defense
CHI	Cloud Height Indicator	DOE	Department of Energy
CNRC	Canadian National Research Council	DOT	Department of Transportation
CONUS	Continental United States	DR	Dead Reckoning
COSPAR	Committee on Space Research	DRO	Denver Regional Office
CRREL	Cold Regions Research and Engineering Laboratory	DSD	Drop Size Distribution

DUAT	Direct User Access Terminal	GALE	Genesis of Atlantic Lows Experiment
EDF	Exploratory Development Facility	GAMA	General Aviation Manufacturers Association
EFAS	En Route Flight Advisory Service	GASP	Global Air Sampling Program
EFWAS	En Route Flight Weather Advisory Service	GDAS	Global Data Assimilation System
EMP	Electromagnetic Pulse	GE	General Electric
EPA	Environmental Protection Agency	GEM	Generalized Exponential Markov
ERL	Environmental Resesarch Laboratory	GMT	Greenwich Mean Time
ETABS	Electronic Tabulator Display System	GOES	Geostationary Operational Environmental Satellite
EWEDS	En Route Weather Display System	GPS	Global Positioning System
FA	Area Forecast	GWD	Global Weather Dynamics
FAA	Federal Aviation Administration	HAA	Helicopter Association of America
FAR	Federal Aviation Regulation	HIFT	Helicopter Icing Flight Test
FBO	Fixed Base Operation	HISS	Helicopter Icing Spray System
FC	Forecase Observations From Mesoscale Model	HIWAS	Hazardous In-flight Weather Advisory Service
FL	Flight Level	HUD	Heads-Up Display
FNOC	Fleet Numerical Oceanography Center	IAF	Initial Approach Fix
FSDPS	Flight Service Data Processing Systems	IAS	Indicated Air Speed
FSAS	Flight Service Automation System	IATA	International Air Transport Association
FSF	Flight Safety Foundation	ICAO	International Civil Aviation Organization
FSM	Forward-Scatter Meter	ICMSSR	Interdepartmental Committee for Meteorological Services and Supporting Research
FSS	Flight Service Station	ICS	Intercommunication System
FT	Terminal Forecast		
FY	Fiscal Year		

IFR	Instrument Flight Rules	LLWSAS	Low-Level Wind Shear Alert System
ILS	Instrument Landing system	LORAN	Long-Range Navigation
IMC	Instrument Meteorological Conditions	LPATS	Lightning Position and Tracking System
INS	Inertial Navigation System	LFM	Limited Fine Mesh
IRT	Icing Research Wind Tunnel	LSA	Leased Service A
IVRS	Interim Voice Response System	LWC	Liquid Water Content
JAWOS	Joint Aviation Weather Observation System	LWI	Laser Weather Identifier
JAWOP	Joint Automated Weather Observing Program	MARS	Microwave Atmospheric Remote Sensor
JAWS	Joint Airport Weather Studies	MCIDAS	Man-Computer Interactive Data System
JDOP	Joint Doppler Operational Project	MDA	Minimum Decision Altitude
JFK	John F. Kennedy Airport	MERIT	Minimum Energy Routes using Interactive Techniques
JPL	Jet Propulsion Laboratory	MIST	Microburst and Severe Thunderstorm
JSPO	Joint Systems Program Office	MIT	Massachusetts Institute of Technology
LaRC	Langley Research Center	MLW	Maximum Landing Weight
LATAS	Laser True Airspeed System	MODE-S	S Band Operational Mode
LAWS	Low-Altitude Wind Shear	MOS	Multiple Output Statistics
L/D	Lift-to-Drag	MSFC	Marshall Space Flight Center
LDV	Laser-Doppler Velocimeter	MSL	Mean Sea Level
LEDWI	Light Emitting Diode Weather Identifier	MTOW	Maximum Take-Off Weight
LFM	Limited Fine Mesh	MVD	Median Volume Diameter
LLP	Lightning Location and Protection, Inc.	NAC	National Avcomp's Council
LLWS	Low-Level Wind Shear	NACA	National Advisory Committee on Aeronautics

NADIN	National Airspace Data Interchange Network	NSSFC	National Severe Storms Forecast Center
NAS	Naval Air Station	NSSL	National Severe Storms Laboratory
NASA	National Aeronautics and Space Administration	NTC	NEXRAD Technical Requirements
NASNET	National Airspace System Network	NTSB	National Transportation Safety Board
NASP	National Airspace System Plan	NWS	National Weather Service
NAVAIDS	Navigational Aids	OA	Office of Audits
NB	Nanobars	OAT	Outside Air Temperature
NBAA	National Business Aircraft Association	OFCM	Office of the Federal Coordinator for Meteorology
NCAR	National Center for Atmospheric Research	OIG	Office of Inspector General
NESDIS	National Environmental Satellite Data and Information Service	OPARS	Optimum Path Aircraft Routing System
NEXRAD	Next Generation Weather Radar	OWRM	Office of Weather Research and Modification
NHC	National Hurricane Center	PA	Position Analyzer
NHRE	National Hail Research Experiment	PATWAS	Pilot Automatic Telephone Weather Answering Service
NM	Nautical Miles	PDP	Program Development Plan
NMC	National Meteorological Center	PEPS	Primary Environmental Processing System
NOAA	National Oceanic and Atmospheric Administration	PIREP	Pilot Report
NOGAPS	Naval Oceanographic Global Atmospheric Prediction System	PIRM	Pressure Ice Rate Meter
NOTAM	Notice To Airmen	PMS	Particle Measuring Systems
NPRM	Notice of Proposed Rule-Making	PROFS	Prototype Regional Observation and Forecast System
NRL	Naval Research Laboratory	PSBT	Pilot Self-Briefing Terminal
NSF	National Science Foundation	PVD	Plan View Display
		RAA	Regional Airline Association

RAE	Royal Aircraft Establishment	SVR	Slant Visual Range
RAOB	Radar Observation	SWAP	Severe Weather Avoidance Plan
RCO	Remote Controlled Observations	SWIS	Satellite Weather Information Service
R&D	Research and Development	TAS	True Air Speed
RE&D	Research, Engineering, and Development	TASC	The Analytical Sciences Corporation
RF	Radio Frequency	TCV	Terminal Configured Vehicle
RMS	Root-Mean-Square	TDR	Terminal Doppler Radar
R&T	Research and Technology	TDWR	Terminal Doppler Weather Radar
RRWDS	Remote Radar Weather Display System	TG/SIS	Task Group on Surface Instrumentation Standards
RSRE	Royal Signals and Radar Establishment	TIDS	Terminal Information Display System
RTA	Remote Terminal for AFOS	TOA	Time of Arrival
RVR	Runway Visual Range	TOMS	Total Ozone Mapping Spectrometer
SAO	Standard Airways Observation	TRACON	Terminal Radar Approach Control Facility
SAR	Synthetic Aperture Radar	TRIP	Thunderstorm Research International Program
SCATR	Specific CAT Risk	TSC	Transportation Systems Center
SD	Storm Detection	TVA	Tennessee Valley Authority
SERI	Solar Energy Research Institute	TWEB	Transcribed Weather Broadcast
SESAME	Severe Environmental Storm and Mesoscale Experiment	UDRI	University of Dayton Research Institute
SIGMET	Significant Meteorological Advisory	UHF	Ultra-High Frequency
SIGWX	Significant Weather Advisory	UK	United Kingdom
SNR	Signal To Noise Ratio	UND	University of North Dakota
SST	Supersonic Transport	USAF	United States Air Force
STOL	Short Takeoff and Landing	USCG	United States Coast Guard
SUNY	State University of New York	USN	United States Navy

UTSI	University of Tennessee Space Institute	WSFO	Weather Service Forecast Office
UWS	United Weather Service	WSI	Weather Service International
VAS	VISSR Atmospheric Sounder	WSO	Weather Service Office
VFR	Visual Flight Rules	WSR	Weather Surveillance Radar
VHF	Very High Frequency	WX	Weather
VISSR	Visible and Infrared Spin Scan Radiometer		
VLF	Very Low Frequency		
VMC	Visual Meteorological Condi- tions		
VOR	VHF Omnidirectional Radio Range		
VRS	Voice Response System		
VS/ERI	Vertical Speed/Energy Rate Indicator		
VSI	Vertical Speed Indicator		
VS/ERI	Vertical Speed/Energy Rate Indicator		
WAVE	Wind, Altimeter, and Voice Equipment		
WBRR	Weather Bureau Remote Radar		
WFC	Wallops Flight Center		
WFMU	Weather and Fixed Map Unit		
WMO	World Meteorological Organi- zation		
WMSC	Weather Message Switching Center		
WPAFB	Wright Patterson Air Force Base		
WPL	Wave Propagation Laboratory		

**APPENDIX B
ROSTER OF WORKSHOP PARTICIPANTS**

NAME	ADDRESS	TELEPHONE
D. Neil Allen	Systems Manager Satellite Earth Station Colorado State University Department of Atmospheric Sciences Fort Collins, CO 80525	303/491-8233
B. Jeffrey Anderson	Aerospace Engineer NASA Marshall Space Flight Center Atmospheric Sciences Division ED44 Huntsville, AL 35812	205/453-0946
Stanley T. Aoyagi	Senior Vice President Pacific Fuel Trading Corporation 650 South Grand Ave., Suite 514 Los Angeles, CA 90017	415/579-0428
Ward J. Baker	Senior Staff Engineer Eng. & Air Safety Department Air Line Pilots Association 1625 Massachusetts Ave., N. W. Washington, DC 20036	202/797-4189
Emanuel M. Ballenzweig	Asst. Fed. Coordinator for DOT/FAA Meteorological Affairs Office of Federal Coordinator for Meteorology 11426 Rockville Pike, Suite 300 Rockville, MD 20852	301/443-8704
Donald W. Beran	Deputy Director STORM Program Office, R/E/3 NOAA 325 Broadway Boulder, CO 80303	303/497-6765
Capt. Daniel D. Berlinrut	AFIT PhD Student U. S. Air Force DET AFIT/CIMI UTSI Tullahoma, TN 37388-8897	615/455-0631 x309
James C. Blair	Deputy Director Systems Dynamics Laboratory ED01 George C. Marshall Space Flight Center NASA Marshall Space Flight Center, AL 35812	205/544-1414

John Blasic	NWS Representative to FAA FAA Headquarters ADL-15 800 Independence Ave., S. W. Washington, DC 20591	202/287-0022
Billie F. Boyd	Staff Meteorologist USAF ESMC/WE Patrick AFB, FL 32925	305/494-5915
C. Leo Boyd	President Corp. Aviation Consultant CLB Assoc., Inc. 210 Wilmont Drive Kingsport, TN 37663	615/239-8373
Herbert I. Brody	Consultant Sperry Corp. 12000 Old Georgetown Road, #1409 North Rockville, MD 20852	301/984-8335
Malcolm Burgess	Manager, Systems Applications Office NASA Langley Research Center MS-472 Hampton, VA 23665	804/865-3318
Dennis W. Camp	Aviation Safety-Atmospheric Processes Specialist FWG Associates, Inc. R. R. 2, Box 271-A Tullahoma, TN 37388	615/455-1982
Fernando Caracena	Physicist NOAA-ERL Weather Research Program RE/22 Boulder, CO 80301	303/497-6269
Ho-Pen Chang	FWG Associates, Inc. R. R. 2, Box 271-A Tullahoma, TN 37388	615/455-1982
C. L. Chandler	Manager, Weather Analysis Delta Airlines Operations Center - Dept. 091 Atlanta International Airport Atlanta, GA 30320	404/765-6478 or 765-4571

Myron E. Clark	Program Analyst-Weather Programs Federal Aviation Administration FAA/ADL-15 800 Independence Ave. S.W. Washington, DC 20590	202/287-0021
Mike Connelley	Marketing Manager, NEXRAD Raytheon Co. Box 5-1-631 Sudbury, MA 01776	617/440-4375
John W. Connolly	Director of Govt. Affairs Alden Electronics 6311 Golf Course Sq. Alexandria, VA 22307	703/765-1948
William A. Cooper	Scientist National Center for Atmospheric Research P.O. Box 3000 Boulder, CO 80307	303/497-1038
Norman L. Crabill	Aerospace Management NASA Langley Research Center MS 247 Hampton, VA 23665	804/865-3274
Russell Crawford	Coordinator-Flight Control Automation Delta Air Lines Dept. 085 Hartsfield International Airport Atlanta, GA 30320	404/765-6423
Lt. Col. James L. Crook	Chief Airspace Management Branch USAF HQUSAF/XOORF Pentagon Washington, DC 20330	202/697-4399
William R. Day	Captain/Check Airman Northwest Airlines Flight Operations MS 700 St. Paul, MN 55111	612/726-2573
Robert E. Dean	Meteorologist U. S. A. F. Aeronautical Systems Division ASD/WE Wright Patterson AFB, OH 45433	513/255-2208

Lawrence M. Denton	Washington Representative TASC/WSI P.O. Box 19124 Washington, DC 20036	202/296-3262
Armand J. Desmarais	Meteorologist DOC,NOAA,NWS,NMC Development (W/NMC2X4) World Weather Bldg. (206) Washington, DC 20233	301/763-8005
Louis D. Duncan	Supervisory Mathematician CDR/DIR U.S. Army Atmospheric Sciences Lab DELAS-AE-O White Sands Missile Range, NM 88002-5501	505/678-5438
James E. Evans	Asst. Group Leader MIT Lincoln Laboratory Room V-128 P.O. Box 73 Lexington, MA 02173	617/863-5500 x7475
Colin R. Flood	Assistant Director (Public Service) Meteorological Office London Road Bracknell, Berkshire England	U.K. 344/420242
Walter Frost	Director Atmospheric Science Division The University of Tennessee Space Institute Tullahoma, TN 37388-8897	615/455-0631 x217
Steven B. Fuller	President EMI Aerodata 7 N. Brentwood Blvd. St. Louis, MO 63105	314/727-9600
John R. Gallimore	Technical Program Manager FAA Technical Center Atlantic City, NJ 08405	609/484-6385
John P. Garthner	Meteorologist U.S. Navy Fleet Numerical Oceanography Center Monterey, CA 93943-5102	408/646-2718
Thomas H. Genz	Captain-Chief Accident Investigator Northwest Airlines, Inc-ALPA Waelderhaus Spring Valley, WI 54767	715/772-4460

Morton Glass	Physicist Air Force Geophysics Lab Atmospheric Sciences Division Hanscom AFB, MA 01731	617/861-2946
Lt. Col. Richard H. Gramzow	Meteorologist DOD Joint Chiefs of Staff 5818 Jacksons Oak Court Burke, VA 22015	202/695-7833
James W. Hall	Asst. Federal Coordinator for Meteorology DOD Air Force Suite 300 11426 Rockville Pike Rockville, MD 20852	301/770-3464
Arthur L. Hansen	Weather Systems Manager FAA Systems Engineering Service 800 Independence Ave., S.W. AES-4 Washington, DC 20591	202/426-7500
Capt. Edward J. Harrison, Jr.	U.S.N. Military Assistant for Environmental Science Office of the Undersecretary of Defense (Research & Engineering) (R&AT-ELS) Rm. 3D129 The Pentagon Washington, DC 20301	202/695-9604
John W. Hinkelman, Jr.	Program Manager PROFS Program Office Environmental Research Labs NOAA/NCAR 325 S. Broadway Boulder, CO 80301	303/497-6819
John C. Houbolt	Chief Aeronautical Scientist MS-249 NASA Langley Research Center Hampton, VA 23665	804/865-3216
Russell L. Hovey	Asst. Federal Coordinator for Meteorological Services and Supporting Research-DOC Affairs 11426 Rockville Pike, Suite 300 Rockville, MD 20852	301/443-8704

K. H. Huang	Director of R & D FWG Associates, Inc. Research and Development UTSI Research Park, UTSI Tullahoma, TN 37388	615/455-1982
Dale Istwan	Capt. Air Line Pilots Association Ozark Airlines 1620 Horseshoe Ridge Chesterfield, MO 63017	314/532-8992
William H. Jaspersen	Research Meteorologist Control Data Corp. Meteorology Research Dept. P.O. Box 1249B (HQM251) Minneapolis, MN 55440	612/853-3697
John L. Keller	Research Meteorologist University of Dayton Research Institute JPC-201 Dayton, OH 45469	513/229-3921
Vernon W. Keller	Aerospace Engineer NASA/MSFC Atmospheric Sciences Division ED44 Huntsville, AL 35812	205/453-0941
Robert N. Kendall	Director of Standards Flight Safety International Teterboro, NJ 100 Moonachie Ave. Moonachie, NJ 07074	201/939-1810
John Klehr	Systems Engineer Link Flight Simulation Division Singer Company MS 775 Hillcrest Facility, Singer-Link Binghamton, NY 13902	607/772-4695
Col. Kelly Klein	Chief Forecasting Services Division AF Global Weather Central Offutt AFB, NE 68113	402/294-2192
Maj. Robert J. Korose, USAF	Chief Aircrew Training Materials HQ AWS/DNTM Scott AFB, IL 62225	618/256-4731

Ronald L. Lavoie	Chief Program Requirements & Planning Div. NOAA W/OM2 8060 13th Street Silver Spring, MD 20910	301/427-1858
William G. (Bud) Laynor	Deputy Director Bureau of Technology National Transportation Safety Board Washington, DC 20594	202/382-6610
Jean T. Lee	Program Coordinator NSSL 1330 Halley Circle Norman, OK 73069	405/360-3620
Leroy W. Lockwood	Staff Assistant Japan Air Lines Operations & Traffic Office-The Americas 1350 Bayshore Highway, Suite 380 Burlingame, CA 94010	415/877-3332
David M. Lueck	U.S. Army Staff Meteorologist DOD HQDA (DAMI-ISP) Attn: Mr. Lueck Washington, DC 20310-1067	202/695-5509
James Luers	Senior Research Scientist University of Dayton Research Inst. Jesse Philips Center Dayton, OH 45469	513/229-3921
Douglas J. Lundgren	Staff Assistant Air Traffic Control Dept. Aircraft Owners and Pilots Assoc. 421 Aviation Way Frederick, MD 21701	301/695-2206
Walter A. Lyons, CCM	President R-SCAN Corp 511 11th Ave. So. Minneapolis, MN 55415	612/333-1424
Alexander E. (Sandy) MacDonald	Director PROFS, RE/23 NOAA/ERL 325 So. Broadway Boulder, CO 80302	303/497-6852
John McCarthy	Manager, Research Applications Project NCAR P. O. Box 3000 Boulder, CO 80307	303/497-8822

Elaine McCoy	Professor of Aviation Ohio State University Box 3022 Dept. Aviation, OSU Columbus, OH 43210	614/422-1116
Capt. Mike McLane	Staff Weather Officer USAF Instrument Flight Center Flight Directives USAF IFC/FD Randolph AFB, TX 78150	512/652-3077
James C. McLean Jr.	Meteorologist NTSB 800 Independence Ave. S.W. Washington, DC 20594	202/382-6679
Robert G. Miller	Senior Scientist National Weather Service Techniques Development Lab 8060 13th St., Room 810 Silver Spring, MD 20910	301/427-7768
H. Geoffrey Molloy	Captain Qantas Airways Ltd. Flight Operations Kingsford Smith Airport Mascot, N.S.W. AUSTRALIA	02/817-1800
Gerald F. O'Brien	Chief, Basic Observations Branch National Weather Service Data Systems Division 8060 13th Street, OTS21 Silver Spring, MD 20910	301/427-7792
Col. John W. Oliver, USAF	Assistant Deputy Chief of Staff Aerospace Sciences HQ Air Weather Service Military Airlift Command (MAC), USAF HQ AWS/DN Scott AFB, IL 62225-50009	618/256-5879
Ralph P. Pass	Manager Environmental Applications Programs Office TASC One Jacob Way Reading, MA 01867	617/944-6850

Porter J. Perkins	Senior Aerospace Engineer Sverdrup Technology, Inc. NASA Lewis Research Center 21000 Brookpark Rd., MS 4-8 Cleveland, OH 44135	216/433-4000 x 6140
Bill Pickron	Director Flight Ops Support Federal Express P.O. Box 727 Memphis, TN 38194	901/369-3402
John Prodan	President AV-CON 1100 Kings Road, Rt. 1 Rapid City, SD 57702	605/348-9329
John A. Rankin	Flight Technical Officer British Airways Technical Administration - Flt Operations P.O. Box 10 London (Heathrow) Airport Hounslow, Middx ENGLAND	01-759-5511 x-3771
Bob Reich	Staff Engineer Air Line Pilots Assoc. Engineering & Air Safety Dept. 1625 Massachusetts Ave. N.W. Washington, DC 20036	202/797-4197
William T. Reiners	Captain APA P.O. Box 5524 2621 Ave. E. Arlington, TX 76011	817/261-0261
Roger F. Reinking	NOAA/ERL R/E24 325 Broadway Boulder, CO 80303	303/497-6167
Erik Ringnes	Research Engineer FWG Associates, Inc. R. R. 2, Box 271-A Tullahoma, TN 37388	615/455-1984
C. William Rogers	Principal Meteorologist Arvin/Calspan P. O. Box 400 Buffalo, NY 14225	716/631-6808

Bernard W. Shanahan	Supervising Meteorologist Services Policy Bureau of Meteorology, Australia Box 1289K Melbourne, Victoria 3001 Australia	03/8789127
Steve E. Short	Program Manager National Weather Service 8060 13th Street (OSD32) Silver Spring, MD 20915	301/427-7975
Robert Skonezny	Simulation Engineer FlightSafety International Simulation Systems Division 7700 E. 38th Street Tulsa, OK 74145	918/622-0700
Charles H. Sprinkle	Chief, Aviation Services Branch DOC/NOAA/NWS W/OM13 8060 13th Street Silver Spring, MD 20910	301/427-7726
Joseph W. Stickle	Chief Low Speed Aerodynamics Division MS-246-A NASA Langley Research Center Hampton, VA 23665	804/865-2037
Raymond J. Stralka	Meteorologist in Charge-CFWSU FAA/NWS ATO-446-Room 626 800 Independence Ave., S. W. Washington, DC 20591	202/426-8568
James F. Sullivan	Weather Manager USAir Greater Pittsburgh Int'l. Airport Pittsburgh, PA 15231	412/262-7172
Ronald J. Sznaider	Manager Meteorological Product Development Kavouras, Inc. 6301 34th Ave., S. Minneapolis, MN 55450	612/726-9515
John S. Theon	Deputy Director (Acting) Earth Science and Applications Division Office of Space Science and Applications NASA Headquarters Code EET NASA HQ Washington, DC 20546	202/453-1680

Jan Tissot van Patot	Atmospheric Environment Service Training Branch ACET 185 Glengrove Ave., W. Toronto, Ontario Canada M4R 1P4	416/489-5032
Michael Tomlinson	Domestic Aviation Operations Specialist DOC/NOAA/NWS W/OM13X1 8060 13th Street Silver Spring, MD 20910	301/427-7726
Joseph F. Towers	LCDR, USNR-R U. S. Navy VR-57, NAS North Island San Diego, CA 92135	619/437-7101
Richard J. Van Gemert	Manager Travel Services Xerox Corporation Hangar G, Westchester County Airport White Plains, NY 10604	203/968-3673
Lt. Col. Kenneth L. Wantzloeben	Chief, Scientific Services Branch Aerospace Sciences Division 5th Weather Wing (MAC) 5WW/DNS Langley AFB, VA 23665-5000	804/764-5901
Frank E. Wencel	Associate Professor of Meteorology Aeronautical Science Division Embry-Riddle Aeronautical University Daytona Beach, FL 32014	904/252-5561 x1311
David Winer	Manager, Energy Division Office of Environment and Energy AEE-200 Washington, DC 20591	202/755-9717
Rodney Wingrove	Research Engineer MS 210-9 NASA Ames Research Center Moffett Field, CA 94035	415/694-5429
Timothy D. Wise	Optical Physicist Hughes Aircraft-Santa Barbara Research Center 75 Coromar Drive B11/78 Goleta, CA 93117	805/968-3511 x6213

Gary G. Worley

Senior Atmospheric Scientist
TRC Environmental Consultants, Inc.
800 Connecticut Blvd.
East Hartford, CT 06108

203/289-8631
or
(TN)615/455-3381

Don Wylie

Scientist
University of Wisconsin-Madison
Space Science & Engineering Center
1225 W. Dayton St.
Madison, WI 53706

608/263-7458

Andy Yates

Private Consultant
7413 Park Terrace Drive
Alexandria, VA 22307

703/765-7423

1. Report No. NASA CP- 2498		2. Government Accession No.		3. Recipient's Catalog No.	
4. Title and Subtitle Meteorological and Environmental Inputs to Aviation Systems				5. Report Date June 1988	
				6. Performing Organization Code	
7. Author(s) Dennis W. Camp and Walter Frost, Editors				8. Performing Organization Report No. L-16338	
				10. Work Unit No. 175-16-57-50	
9. Performing Organization Name and Address University of Tennessee Space Institute Tullahoma, TN 37388-8897				11. Contract or Grant No.	
				13. Type of Report and Period Covered Conference Publication	
12. Sponsoring Agency Name and Address NASA, Washington, DC 20546; NOAA/(DOC), Rockville, MD 20850; FAA/(DOT), Washington, DC 20553; DOD, Washington, DC 20301; and OFCM, Rockville, MD 20857				14. Sponsoring Agency Code	
				15. Supplementary Notes	
16. Abstract This publication reports the proceedings of a workshop on meteorological and environmental inputs to aviation systems held at the University of Tennessee Space Institute, Tullahoma, Tennessee, March 12-14, 1985. Jointly sponsored by NASA, NOAA (National Oceanic and Atmospheric Administration), FAA (Federal Aviation Administration), DOD (Department of Defense), and OFCM (Office of the Federal Coordinator for Meteorology), the workshop assembled, in round table discussions, many disciplines of the aviation communities. The workshop's major objectives were to satisfy the sponsoring agencies' need for expansion of the understanding and knowledge of atmospheric interaction with aviation systems, to provide better definition and implementation of services to operators, and to discuss collection and interpretation of data for establishing operational criteria relating the total meteorological inputs from the atmospheric sciences to the needs of the aviation communities. The unique aspects of the workshop were the diversity of the participants and the achievement of communication across the interface of the boundaries among pilots, meteorologists, training personnel, accident investigators, traffic controllers, and flight operation personnel from military, civil, general aviation, and commercial interests alike. Representatives from government, including the Department of Defense, airlines, private agencies, aircraft manufacturers, industries, research institutes, and universities attended.					
17. Key Words (Suggested by Author(s)) Aviation safety Meteorology Air traffic control Training Flight operations General aviation Aviation weather research and services			18. Distribution Statement Unclassified - Unlimited Subject Category 47		
19. Security Classif. (of this report) Unclassified		20. Security Classif. (of this page) Unclassified		21. No. of pages 244	22. Price All

**National Aeronautics and
Space Administration
Code NTT-4**

**Washington, D.C.
20546-0001**

**Official Business
Penalty for Private Use, \$300**

**SPECIAL FOURTH-CLASS RATE
POSTAGE & FEES PAID
NASA
Permit No. G-27**

NASA

**POSTMASTER: If Undeliverable (Section 158
Postal Manual) Do Not Return**
