

Electronic Controller for Reciprocating Rotary Crystallizer

Roger L. Kroes, Donald A. Reiss and Howard B. Hester
Space Science Laboratory, Marshall Space Flight Center,
Huntsville, Alabama 35812

RECEIVED
AIAA
LIBRARY
87 FEB -9
5:05

An electronic controller for a reciprocating rotary crystallizer is described. The heart of this system is the electronic timer circuit. A schematic along with a detailed description of its operation is given.

One important and widely used technique for growing large single crystals of high quality from solutions involves the use of the reciprocating rotary crystallizer (RRC). This technique was pioneered in the 1940's at Bell Labs by A.N. Holden and others [1,2]. With it they were able for the first time to produce large quantities of high quality single crystals of ammonium dihydrogen phosphate (ADP) and ethylene diamine tartrate (EDT). The former was used for sonar detection during the war while the latter was used in telecommunications [3,4].

Figure 1 shows the major features of a reciprocating rotary crystallizer. Crystal growth takes place on seed crystals attached to rotary arms which are immersed in a supersaturated solution of the growth material. As the crystals grow they reduce the concentration of the solution, so the temperature is slowly decreased to maintain a relatively constant degree of supersaturation. The quality of the crystals is largely

(NASA-TM-101140) ELECTRONIC CONTROLLER FOR
RECIPROCATING ROTARY CRYSTALLIZER (NASA)
S P CSCI 20L

N88-25354

Unclas
0146698

G3/76

determined by the high stability of temperature control and the regular reciprocating rotary motion of the seed crystals through the solution which provides them with an optimum flow of solution over their surface. This maintains the relatively constant growth rate necessary for quality growth.

The temperature control is usually maintained to an accuracy of ± 0.1 degree C or better and the rotation rate is on the order of 5-10 rpm. The direction of rotation is reversed with a period of about one to five minutes. These are nominal values. Actual values can vary greatly depending on the material being crystallized and the circumstances of growth. The reason for the reciprocating action of the rotor is to reduce any leading edge-trailing edge effects on the growing crystals.

In the past the control of the reversing procedure has generally been by mechanical means. Usually a cam or a screw which triggers a micro switch was used. While such techniques are useful, the equipment often lacks flexibility or is difficult to fabricate. To overcome such problems we have designed an electronic reversing system. A block diagram of the system is shown in figure 2. It consists of a d.c. stirrer motor, a solid state speed controller with a manual reversing switch, and the electronic timer controller. The electronic timer controller consists of a d.c. power supply, the timer circuit, and the reversing relays. The motor with its speed controller can be purchased from any scientific equipment supplier and the components used to construct the electronic

timer controller are also readily available.

The heart of the control system is the timing circuit, the schematic of which is shown in figure 3. It is based on a NE556 dual timer configured for delayed pulse generation[5]. The two 555 timers on this chip are made to trigger each other through a 0.01mf ceramic capacitor. When the output goes low, the capacitor discharges, producing the narrow low-going pulse required for triggering. The timing capacitors are 220mf electrolytics. Electrolytic capacitors are readily available at low cost, and large capacitance values are available in relatively small packages. They tend to have loose tolerances and high leakages which affect the accuracy of the timing circuit, but in this application high accuracy is not required. A number of different timing resistors connected to a multiposition switch provides flexibility in setting the interval between reversals of rotation direction. The duration of each interval is determined by $T(\text{sec.}) = 1.1R_tC_t$. The maximum practical value of R_t is about 13megohms, giving a maximum duration of about 52 minutes. In our circuit the range is 1 minute to about 10 minutes. Shorter times require a smaller capacitance. A 74121 monostable multivibrator is used to provide a pulse at the end of each interval during which the power to the motor is interrupted. This prevents an abrupt change of direction which can put a great deal of stress on the motor and the crystal mounting hardware, especially when the crystals have grown large. Triggering is provided by the low-going outputs of

the 556A and 556B through .01mF capacitors. The output pulse width of the 74121 is determined by the timing capacitor and resistor and is approximately equal to $0.7C_tR_t$. A pulse of .5 to 1 sec. is sufficient.

The timing circuit is used to drive relays which have been wired into the stirring motor controller in place of the manual reversing switch. Reversals are accomplished by a latching relay. Power is applied alternately to the two coils through the 2N2905/2N910 pairs which are driven by the 556 outputs through the 7406 hex inverter. The ground pin of the relay is connected to ground through a pair of 2N2222's which is turned on during the timing period of the 74121. This limits the time that current flows through the coil, preventing overheating. The non-latching relay interrupts the power to the motor at the same time, causing the motor to stop between reversals. This relay is controlled by a pair of 2N2222's driven by the 74121 through the 7406.

When the controller was first used, some electronic noise problems were encountered which interfered with the operation of the 74121. It was thought that the noise was entering through the power leads to the stirring motor controller. The timing circuit was isolated from this noise by placing the relays in a separate metal box and driving them through 6N136 opto-isolators. The 7406 is used to provide the proper inputs for the 6N136 isolators. With these modifications in place the electronic timer controller operated properly and provided us with the

needed flexibility to carry out growth of crystals under a variety of conditions.

References:

- 1) A.H. Holden, Bell Lab. Record, 1947, 25, 458-461.
- 2) A.H. Holden, Discuss. Farady Soc., 1949, 5, 312-315.
- 3) A.C. Walker, Bell Lab. Record, 1947, 25, 357-362.
- 4) A.C. Walker and G.T. Kohman, Trans. Am. Inst. Elec. Engrs., 1948, 67, 565-570.
- 5) W.G. Jung, IC Timer Cookbook, Howard W. Sams & Co., Inc., Indianapolis, 1977.

List of figure captions:

Fig.1. Reciprocating Rotary Crystallizer

Fig.2. Block Diagram of Controller System

Fig.3. Schematic of the Timer Circuit

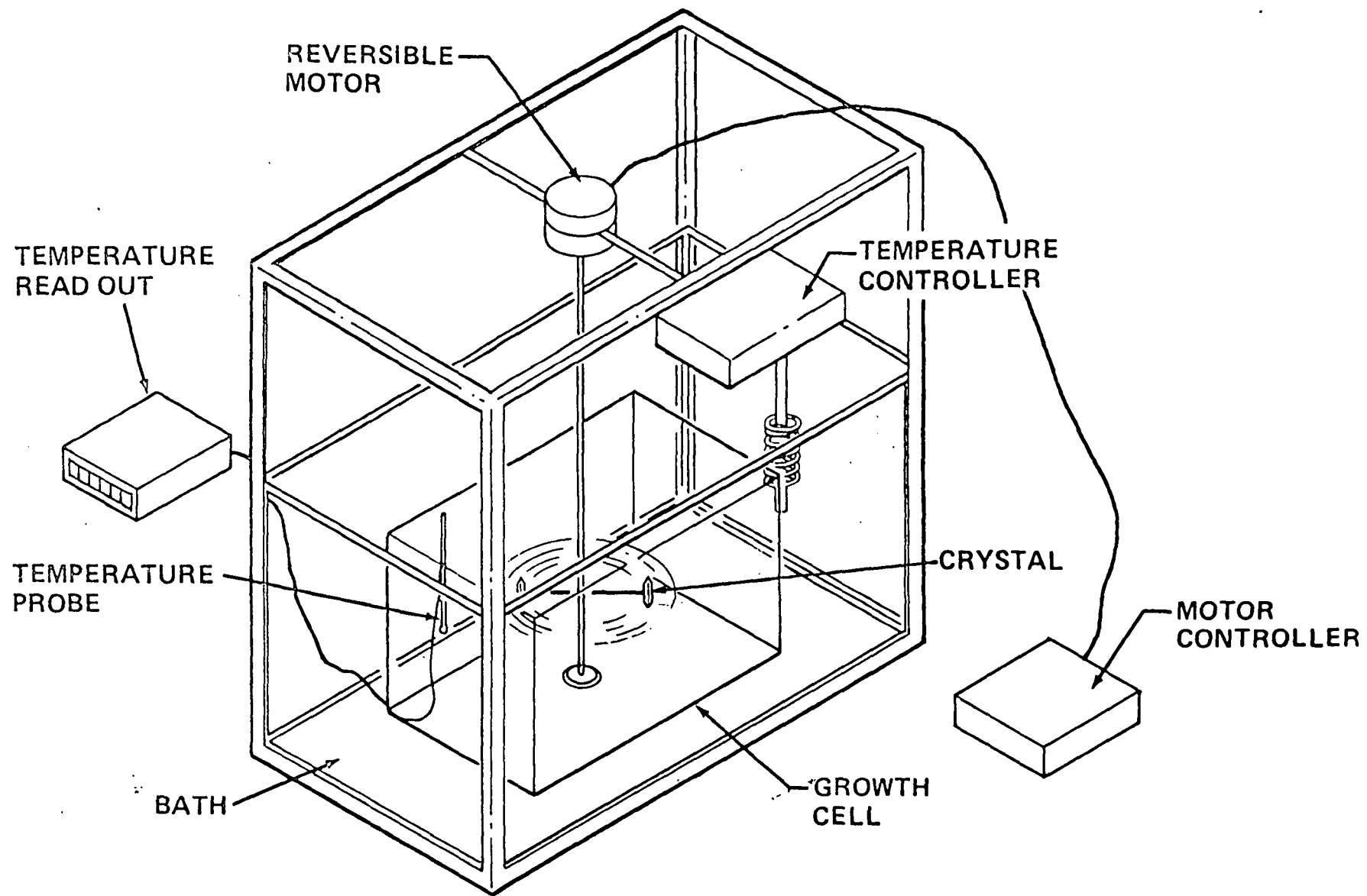

RECIPROCATING ROTARY CRYSTALLIZER

Fig. 1.

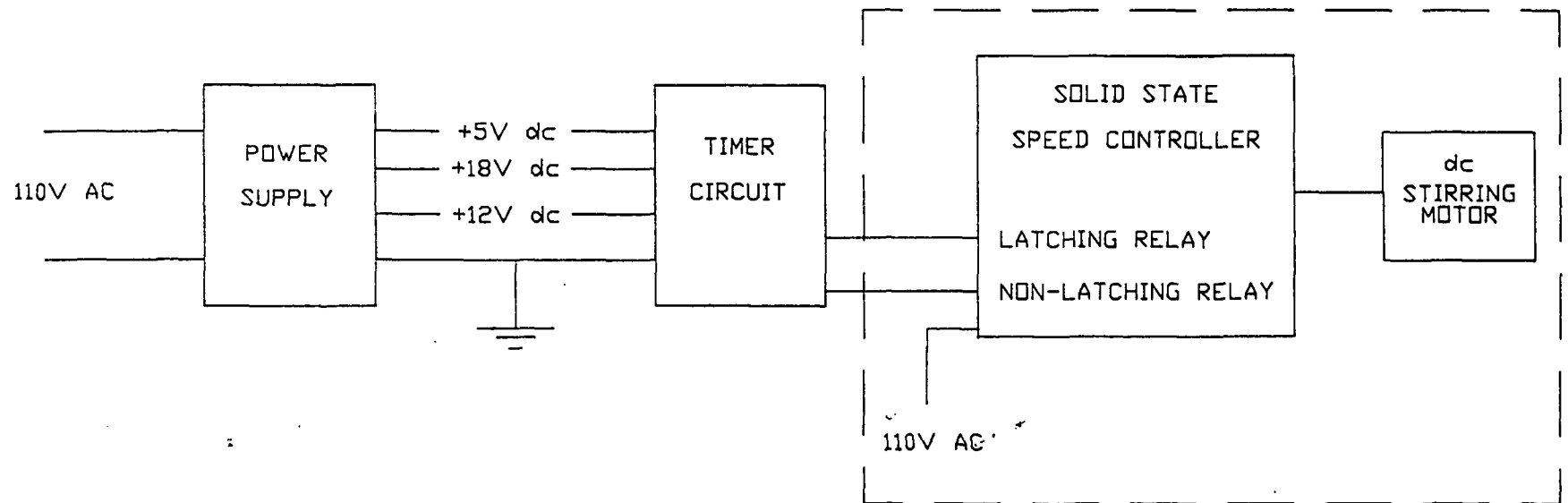
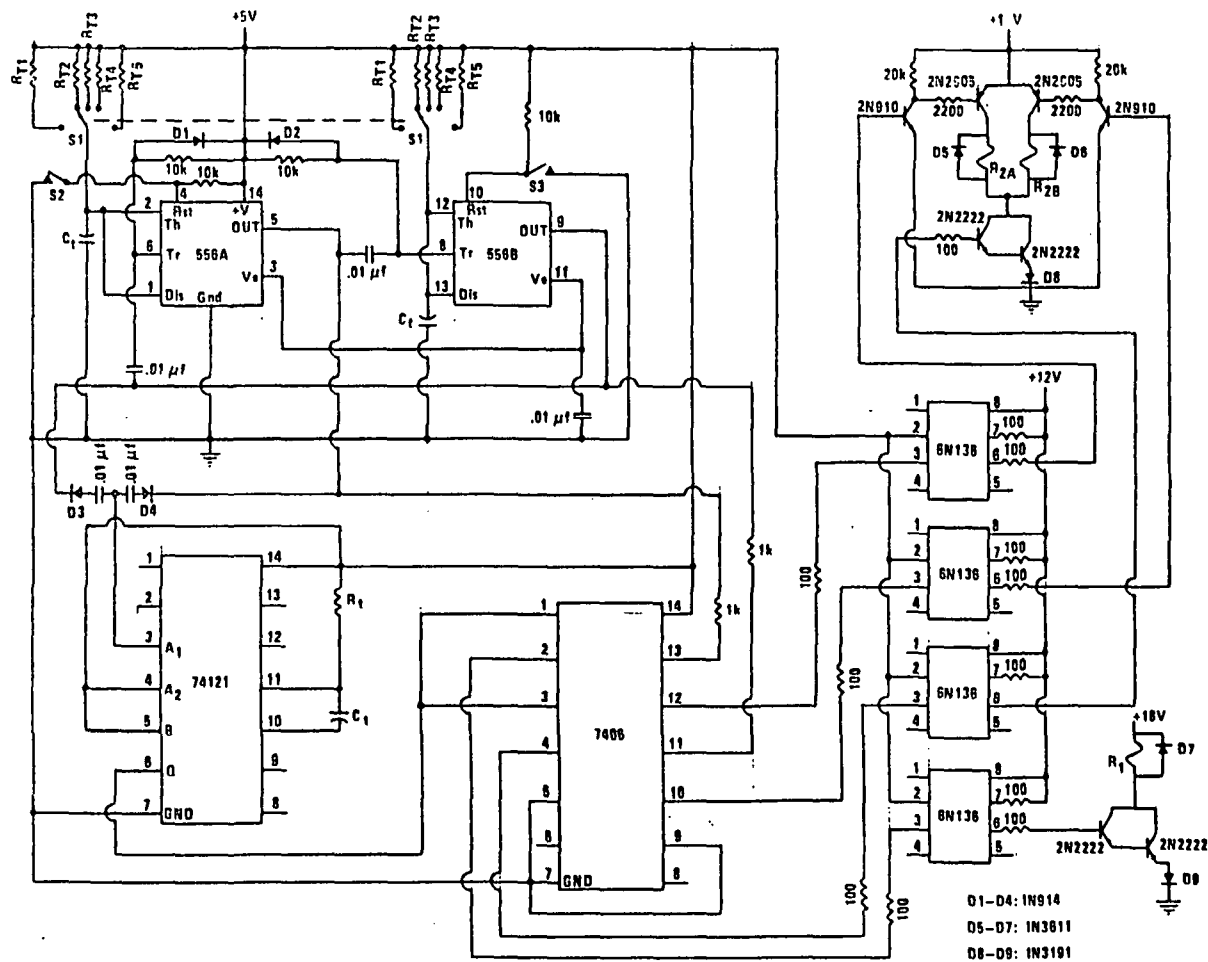

Figure 2



ORIGINAL PAGE IS
 OF POOR QUALITY

Fig. 3.