

NASA Technical Memorandum 100900
SAWE Paper No. 1818

Weight Savings in Aerospace Vehicles Through Propellant Scavenging

(NASA-TM-100900) WEIGHT SAVINGS IN
AEROSPACE VEHICLES THROUGH PROPELLANT
SCAVENGING (NASA) 25 p CSCI 22B

N88-25470

g3/15 Unclas
0149242

Steven J. Schneider and Brian D. Reed
Lewis Research Center
Cleveland, Ohio

Prepared for the
47th Annual Conference on Mass Properties Engineering
sponsored by the Society of Allied Weight Engineers, Inc.
Plymouth, Michigan, May 23-25, 1988

NASA

WEIGHT SAVINGS IN AEROSPACE VEHICLES THROUGH PROPELLANT SCAVENGING

Steven J. Schneider and Brian D. Reed
National Aeronautics and Space Administration
Lewis Research Center
Cleveland, Ohio 44135

SUMMARY

Two basic reasons exist for studying propellant scavenging in aerospace vehicles. First of all, a vehicle payload benefit is gained by utilizing the launch propulsion system reserves and residuals for auxiliary propulsion. Second, the use of a common propellant in the launch and auxiliary propulsion systems simplifies operations and logistics since only one propellant system needs to be serviced. Also, the propellants most probably available for scavenging are hydrogen and oxygen and the use of these propellants for auxiliary propulsion has two additional basic advantages over the use of state-of-the-art Earth-storable propellants. A vehicle payload benefit is gained by utilizing higher specific impulse propellants and hydrogen and oxygen offer the benefits of nontoxic, noncorrosive propellants.

This paper addresses the vehicle payload benefits of scavenging hydrogen and oxygen propellants. The approach used is to select a vehicle and a mission and then select a scavenging system for detailed weight analysis. The Shuttle II vehicle on a Space Station rendezvous mission is chosen for study. The propellant scavenging system scavenges liquid hydrogen and liquid oxygen from the launch propulsion tankage during orbital maneuvers and stores them in well insulated liquid accumulators for use in a cryogenic auxiliary propulsion system. The fraction of auxiliary propulsion propellant which may be scavenged for propulsive purposes is estimated to be 45.1 percent. The auxiliary propulsion subsystem dry mass, including the proposed scavenging system, an additional 20 percent for secondary structure, an additional 5 percent for electrical service, a 10 percent weight growth margin, and 15.4 percent propellant reserves and residuals is estimated to be 6331 kg (13958 lbm).

This study shows that the fraction of the on-orbit vehicle mass required by the auxiliary propulsion system of this Shuttle II vehicle using this technology is estimated to be 12.0 percent compared to 19.9 percent for a vehicle with an Earth-storable bipropellant system. This results in a vehicle with the capability of delivering an additional 7820 kg (17241 lbm) to the Space Station.

INTRODUCTION

The Shuttle II (refs. 1 to 4) is a fully recoverable two-stage vehicle which promises to meet many of the space transportation needs in the post-Shuttle era. A major proposed mission for this vehicle is the rendezvous with and the delivery of cargo to the Space Station. The version of this vehicle chosen for analysis in this study has an orbiter stage as depicted in figure 1. This vehicle is 49.7 m (163 ft) long, has a dry weight of 85 275 kg (188 000 lbm) and has integral cryogenic hydrogen and oxygen propellant tanks. Based on experience with the current Shuttle (ref. 5), the residuals and reserves of cryogenic propellants in the launch propulsion tankage at Main Engine Cut Off

E-4079

(MECO) are estimated to be 2722 kg (6000 lbm) of hydrogen and 5443 kg (12 000 lbm) of oxygen. The vehicle payload benefits of scavenging these trapped hydrogen and oxygen reserves and residuals from the integral launch propulsion tankage and using these propellants for auxiliary propulsion is the subject of this study. An equally important benefit not studied here is the possibility of simplifying ground operations of the vehicle by using common propellants for both the launch and auxiliary propulsion systems and by using nontoxic, noncorrosive propellants. A review of the hydrogen-oxygen auxiliary propulsion technology (ref. 6) for the thrusters has already been published citing the technology program for the current Shuttle orbiter. The need remains to determine the propellant management system parameters such that component development work can begin.

This paper proposes such a propellant management system and develops a component weight analysis (including secondary structure, electrical service and growth margin) such that a system weight can be estimated for this Shuttle II vehicle on a Space Station rendezvous mission. This analysis uses the English units as primary units and then converts to metric units. One notes that throughout the paper, more precision is used than the accuracy of the calculations merits. This is done to minimize the roundoff errors in the summation of the weights of numerous of small components. The assumption is made in this weight analysis that the orbital maneuvering system (OMS) impulse requirements are met by simultaneously firing primary reaction control system (RCS) thrusters. The payload benefit to the vehicle is then estimated based on this weight analysis and the demonstrated performance of hydrogen-oxygen auxiliary propulsion thrusters. The mission events schedule and auxiliary propulsion requirements for this vehicle-mission combination are given in table I.

SYMBOLS

f_d	dry mass fraction of the auxiliary propulsion system
f_s	fraction of mission required auxiliary propellant which is scavenged
g	gravitational constant at Earth's surface
I_s	average specific impulse of auxiliary propulsion system
M_{acc}	mass of propellant in accumulator
M_d	auxiliary propulsion system dry mass including propellant reserves and residuals
M_{liq}	mass of propellant in main tanks in liquid state
M_{lost}	mass of propellant vented overboard
M_{orbit}	total mass of vehicle in orbit
M_p	total mass of auxiliary propellant required for the mission
M_{p1}	mass of auxiliary propellant loaded into the accumulator on the ground

M_{ps}	total mass of auxiliary propellant which is scavenged from the launch propulsion system
M_{scav}	mass of auxiliary propellant scavenged during a specific orbital maneuver
M_{tot}	total mass of propellant in the main tank
M_{vap}	mass of propellant in the main tank in the vapor state
P	pressure in the main tank
T	temperature in the main tank
X	quality of propellant in main tank
ΔV	total vehicle change in velocity to be supplied by the auxiliary propulsion system

BENEFITS OF PROPELLANT SCAVENGING

Propellant scavenging in aerospace vehicles is accomplished within the framework of an integrated propulsion system. An integrated propulsion system is defined in this paper to be one that has the necessary plumbing and transfer apparatus to manage vehicle propellant reserves and residuals in a manner such that the total propellant mass is minimized. Launch system propellant remaining after MECO is not jettisoned in such a system but is scavenged for use in the OMS and RCS. The integration of propellant supplies represents a certain risk to the mission from an interface point of view, but it can easily offer required redundancy for fail-return operation of the vehicle.

Present shuttle. - The OMS and RCS on the present shuttle are pressure-fed propulsion systems utilizing storable hypergolic propellants (monomethyl hydrazine and nitrogen tetroxide). The RCS is comprised of three subsystems: one in the forward module and one in each of two aft propulsion modules as shown in figure 2. Also contained in each of the two aft propulsion modules is an OMS subsystem. The OMS and RCS subsystems are presently integrated to the extent that interconnection of propellant supplies within each of the propulsion modules and cross-connection between aft modules is provided. This allows the OMS and aft RCS to operate from either propellant supply and to operate on propellants from the opposite side of the vehicle for vehicle trimming.

Each aft module contains one 26 690 N (6000 lbf) thrust OMS engine with a specific impulse of 313 sec and primary RCS engines, each with a thrust level of 3870 N (870 lbf) and a specific impulse of 280 sec. In addition, each aft module contains 2 vernier RCS engines, each with a thrust level of 107 N (24 lbf) and a specific impulse of 260 sec. The forward module contains 14 primary RCS engines and 2 vernier RCS engines. The total auxiliary propulsion engine count on the present Shuttle is 2 OMS engines, 38 primary RCS engines and 6 vernier RCS engines.

Future aerospace vehicles. - The integrated propulsion system (ref. 6) on advanced aerospace vehicles may use hydrogen and oxygen as propellants for the

auxiliary propulsion subsystem (OMS and RCS) possibly taking advantage of scavenging propellants from the launch subsystem. These propellants have a higher specific impulse than storable hypergolic propellants. The integrated hydrogen/oxygen (H/O) auxiliary propulsion subsystem may have a higher subsystem dry mass fraction, but scavenging of propellants can lead to a lower on-orbit mass fraction required by the total auxiliary propulsion subsystem. The following analysis shows these tradeoffs. The rocket performance equation can be written:

$$\frac{M_p}{M_{\text{orbit}}} = 1 - \exp\left(\frac{-\Delta V}{I_s g}\right)$$

The dry mass fraction of the auxiliary propulsion system is defined

$$f_d = \frac{M_d}{M_d + M_p}$$

The total mass of auxiliary propellant (M_p) is the sum of the mass of auxiliary propellant which is loaded (M_{p1}) into the auxiliary propulsion tankage on the Earth and the mass of auxiliary propellant which is scavenged (M_{ps}) from the launch propulsion system after MECO.

$$M_p = M_{p1} + M_{ps}$$

The fraction of the total auxiliary propellant which is scavenged is defined as

$$f_s = \frac{M_{ps}}{M_p}$$

Combining these equations, the on-orbit mass fraction required by the auxiliary propulsion system can be written:

$$\frac{M_{p1} + M_d}{M_{\text{orbit}}} = \left(\frac{1 - f_s + f_s f_d}{1 - f_d}\right) \left[1 - \exp\left(\frac{-\Delta V}{I_s g}\right)\right]$$

This quantity is plotted as a function of auxiliary propulsion system velocity increment in figure 3. A comparison is made of the unscavenged ($f_s = 0$) auxiliary propulsion system on-orbit vehicle mass fraction typical of the present shuttle (average specific impulse, $I_s = 310$ sec) with that of an unscavenged H/O auxiliary propulsion system (average specific impulse of 427 sec). This high specific impulse assumes that the H/O propellants can be used in the liquid state by the auxiliary propulsion system thus requiring no propellant thermal conditioning. Typical shuttle mission data shown by the symbols are obtained from reference 5. The missions include: 29 500 kg (65 035 lbm) payload launched due east, 11 300 kg (24 912 lbm) payload launched on a sortie mission, 14 500 kg (31 967 lbm) payload launched on a deploy mission, and 1130 kg (2491 lbm) launched on a retrieve mission. These data show an auxiliary propulsion system dry mass fraction of $f_d = 0.3$ for the storable hypergolic propellants.

When the subsystems are integrated, propellant is scavenged from the launch propulsion subsystem after MECO, thus reducing the required propellant mass that is loaded into the auxiliary propulsion subsystems on Earth (M_{p1}). The on-orbit vehicle mass fraction required by the auxiliary propulsion system (ordinate) then decreases as shown in figure 3. The minimum is achieved when 100 percent of the required propellant is scavenged.

PROPELLANT MANAGEMENT SYSTEM OPERATION

A propellant management system for advanced aerospace vehicles is sketched in figure 4. This system features the scavenging of liquid propellants from the launch propulsion tanks through thermal subcoolers (ref. 7) (Items 15 and 21) to well insulated tanks or liquid accumulators (Items 11 and 17) to protect them from environmental heat soak. This scavenging of main engine reserves and residuals is accomplished after MECO by a combination of capillary acquisition devices, accelerations induced by the orbital maneuvers and special propellant settling maneuvers. This scavenging must occur early in the flight to prevent the heat soak from gassing the propellants in the launch propulsion tanks and eventually causing the venting of the bulk of the propellants overboard. These liquid accumulators are loaded on the ground with at least their minimum load of 60 percent capacity to prevent dynamic problems during launch. Propellant scavenging begins immediately after MECO to fill the tanks and continues during the firing of the orbital maneuvering engines to replenish the propellant which is drawn from the accumulators.

The cryogenic propellant distribution system to the thrusters was first proposed (ref. 8) in 1972 during the shuttle development program. This distribution system has no propellant heating equipment with its associated weight and system performance penalties since auxiliary propulsion thrusters have been demonstrated (ref. 9) to operate on cryogenic hydrogen and oxygen. In this system the cryogenic liquids are pumped from the low pressure accumulators through thermal subcoolers (Items 12 and 18) into a high pressure (3450 to 6900 kPa, 500 to 1000 psia) distribution system (Items 3 and 6) to the thrusters. Heat leaks and pressure drops which cause pump cavitation can be avoided by locating the pumps near the tanks. Contracted bellows accumulators (Items 4 and 7) are attached to this distribution system to allow for expansion of the fluid as heat soaks into the system. This allows a propellant temperature rise from cryogenic temperatures to space ambient temperature without loss of propellant. Small circulation pumps (Items 23 and 24) are provided in each manifold for circulating the propellants to maintain uniform manifold temperatures and to actively cool the valves, injectors and igniters on the thrusters. The need for vacuum jacketed lines has not been established. If they are required, however, they will afford dual containment of the propellant for a reliability improvement. Also, the need for some isolation valves can then be eliminated by monitoring the vacuum in the jacket during checkout and flight. The thruster system will operate as a pressure-fed system during contraction of the bellows, making the system response times insensitive to pump start up times. If the systems are pressurized to at least 3450 kPa (500 psia), the delivery of single phase (supercritical) hydrogen is ensured because its critical pressure is 1290 kPa (187 psia). Two phase oxygen could occur, however, at the pressure of 3450 kPa (500 psia) since its critical pressure is 5044 kPa (731 psia). If this should happen, the oxidizer to fuel ratio is reduced to the thruster which is a fail-safe condition. This condition is minimized, however, because as heat soaks into this system, the pressure rises to 6900 kPa (1000 psia) as the fluid expands into the bellows.

The liquid hydrogen/liquid oxygen (LH₂/LO₂) primary reaction control system (RCS) thrusters (Item 1) are assumed to be 4448 N (1000 lbf) thrust each and the vehicle would be configured with these thrusters much the same as the present Shuttle. The aft modules shown in figure 2, however, would be incorporated into the aft end of the vehicle. This can be accomplished because this vehicle is physically much larger than the present Shuttle due to the internal propellant tankage. For this analysis, the assumption has also been made that the orbital maneuvering system (OMS) impulse requirements are met by simultaneously firing 12 primary RCS thrusters. This requirement is satisfied by the addition of 8 primary RCS thrusters in the aft end of the vehicle.

Propellant remaining in the launch propulsion tankage when in orbit will become superheated vapor within a short time due to thermal heat soak. These tanks are then used as low pressure gas accumulators which deliver gaseous propellants through distribution lines (Items 25 and 26) to low pressure vernier RCS thrusters (Item 2). These gaseous hydrogen/gaseous oxygen (GH₂/GO₂) vernier RCS thrusters are assumed to be 111 N (25 lbf) thrust each and the vehicle would be configured with these thrusters much the same as the present shuttle (see fig. 2) to provide attitude control while in orbit.

Propellant management for the Shuttle II vehicle on a Space Station rendezvous mission is given in table II where the events are described in table I. The dry weight of the orbiter is 85 275 kg (188 000 lbm) and based on the external tank mass properties of the present Shuttle (ref. 5), an estimated 2722 kg (6000 lbm) of hydrogen and 5443 kg (12 000 lbm) of oxygen resides in the main tanks at MECO. A simple thermodynamic calculation of liquid expulsion from the hydrogen tanks originally full of liquid at 173 kPa (25 psia) and 22.2 K (40 °R) indicates that the quality (x) of the hydrogen is 0.0713 and that it resides in the tank at a pressure of 7.66 kPa (1.11 psia) and a temperature of 13.9 K (25 °R). The same calculation for the oxygen tanks originally full of liquid at 207 kPa (30 psia) and 97.8 K (176 °R) indicates that its quality is 0.0829 and that it resides in the tank at a pressure of 15.8 kPa (2.29 psia) and 75.6 K (136 °R). The hydrogen liquid accumulator is launched 60 percent full with a propellant load of 744 kg (1640 lbm) and the oxygen liquid accumulator is launched 100 percent full with a propellant load of 4906 kg (10 816 lbm). As shown in table I, 10 284 kg (22 672 lbm) of propellants are required to accomplish this Space Station rendezvous mission. The propellant scavenged is the required propellant plus reserves minus the propellant loaded into the system on Earth.

The heat soak into the launch propulsion tankage determines the time frame during which the propellants must be scavenged. This heat flux will vary substantially during an orbit, depending on whether or not the vehicle is in the shadow of the Earth. For this Space Station rendezvous mission, however, the quantity of propellant scavenged is determined not to be sensitive to as much as a factor of two increase in the assumed heat flux because all of the liquid propellant scavenging is completed within 2 hr of MECO. The estimates of the orbital average heat flux are derived from data on the Saturn S-IVB stage (ref. 10). These estimates are based on a heat flux of 114.0 W/m² (36 Btu/hr-ft²) into the tanks for a heat load on the hydrogen tank of 53.8 kW (183 589 Btu/hr) and on the oxygen tank of 13.7 kW (46 756 Btu/hr).

The ground rules of the scavenging process are that whenever accumulators are not full, propellants are to be scavenged to fill them. Therefore, during

Event No. 2 (45 min delay), 495 kg (1091 lbm) of liquid hydrogen is scavenged to fill the accumulator to its full load of 1239 kg (2731 lbm). No oxygen is scavenged, however, since the accumulator was launched full. During Event No. 3, 654 kg (1442 lbm) of propellant are used from the accumulators for propulsive purposes. Therefore, 119 kg (262 lbm) of liquid hydrogen and 535 kg (1180 lbm) of liquid oxygen are scavenged during the maneuver to keep the accumulators full. The quantities of liquid propellants which are scavenged are listed in table II for each event of table I and the qualities of the propellants in the main tanks are calculated under the given heat load and liquid propellant extraction rate. From table II, one can see that by the time Event No. 8 (Closure and Dock) is completed at 6965 sec after MECO, the quality of the hydrogen in the main tank is 0.566 and the quality of the oxygen in the main tank is 0.564. At this point, liquid scavenging is complete having scavenged 54.7 percent of the originally available liquid hydrogen and 80.0 percent of the originally available liquid oxygen.

Once the desired orbit has been achieved, there is a long period of low propulsive needs indicated by Event No. 9 (72 hr orbit maintenance). During this time, the heat load on the hydrogen tank vaporizes the remaining 581 kg (1281 lbm) of liquid hydrogen, and the pressure in the tank rises to 173 kPa (25 psia), at which pressure relief venting occurs. This venting occurs until the space ambient temperature of 278 K (500 °R) is reached. Upon completion of Event No. 9, 1009 kg (2225 lbm) of hydrogen has been vented, 240 kg (529 lbm) has been scavenged as gaseous hydrogen and used for propulsive purposes and 90 kg (198 lbm) of gaseous hydrogen remains in the tank which is vented and filled with inert gas during Event No. 10 (de-orbit). During Event No. 9, the heat load on the oxygen tank also vaporizes the remaining 632 kg (1393 lbm) of liquid oxygen, however, no venting occurs because when the space ambient temperature of 278 K (500 °R) is reached, the maximum pressure of 207 kPa (30 psia) is not reached. Upon completion of Event No. 9, 600 kg (1322 lbm) of gaseous oxygen has been scavenged and used for propulsive purposes and 850 kg (1873 lbm) of gaseous oxygen remains in the tank which is vented and filled with inert gas during Event No. 10 (de-orbit).

The analysis provided here shows the vehicle landing with 409 kg (902 lbm) of liquid hydrogen and 1173 kg (2586 lbm) of liquid oxygen. These numbers represent a 20.9 percent mission reserve for hydrogen and an 14.1 percent mission reserve for oxygen. In all, 4634 kg (10 216 lbm) of propellants were scavenged for propulsive purposes. The fraction (f_s) of the mission required propellant (10 284 kg, 22 672 lbm) which is scavenged is 0.451.

DETAILED WEIGHT ANALYSIS

The weight savings on this Shuttle II vehicle due to this propellant scavenging system can be determined when the dry mass of the auxiliary propulsion, scavenging and distribution system are determined. Components which are a part of this auxiliary propulsion system are given item numbers in figure 4 and are the subject of this detailed weight analysis. They are tabulated along with the quantity required, the weight per unit and the total weight for the item in table III. A description of the basis for these weights is given in Appendix A. Once these component weights are determined, the mass properties of the present Shuttle OMS and RCS systems (ref. 5) are used to adjust the system weight for electrical service to its components and for secondary structure and installation hardware. These adjustments are determined to be 5 and 20 percent,

respectively, and these percentages are added to the total mass in table III. Finally, a 10 percent weight growth margin is added to the adjusted total to reflect the potential of weight growth in advanced vehicle designs. The auxiliary propulsion, scavenging, and distribution system dry weight is then determined to be 4749 kg (10 470 lbm). The auxiliary propulsion system dry mass (M_d) defined previously is then the sum of this hardware weight plus the weight of the auxiliary propulsion system propellant remaining in the accumulators at the end of the mission as given in event No. 10 of table II. The dry mass (M_d) is then 6331 kg (13 958 lbm). The dry mass fraction (f_d) of the auxiliary propulsion system defined previously is then 0.381 where the total propellant mass is given in table I. This dry mass fraction is larger than the dry mass fraction (0.3) of the state-of-the-art Earth storable bipropellant system as shown by data in figure 3. Based on this detailed weight analysis another line has been plotted on figure 3 at the parameters $f_d = 0.381$, $f_s = 0.451$ to show the effect on the on-orbit vehicle weight of incorporating this technology into Shuttle II. The on-orbit vehicle mass fraction required by the auxiliary propulsion on the Shuttle II is reduced from 0.199 for an Earth storable bipropellant system to 0.120 for this H/O system. This technology gives a Shuttle II vehicle with the capability to deliver an additional 7820 kg (17 241 lbm) to the Space Station given the same launch propulsion system performance and an initial on-orbit weight of 99 090 kg (218 456 lbm). This additional payload has contributions due to scavenging of 45.1 percent of the mission required auxiliary propellant and due to the specific impulse increase of the auxiliary propulsion system from 310 to 427 sec.

All of the pumps and compressors are sized such that electric motors can supply the required work. The peak power requirement can be determined by assuming simultaneous operation of all the pumps and compressors as is required during a 53.4 kN (12 000 lbf) thrust orbital maneuver. This peak power requirement is 367 kW (492 hp) and is comparable to the power requirements during launch and landing for an all electric vehicle. Preliminary designs of flight prototype hydrogen-oxygen auxiliary power units (ref. 11) (APU) of this size have been developed in the technology program for the present Shuttle. These units are projected to have a specific fuel consumption of 1.1 kg/kWh (1.8 lbm/hph) and to operate at a mixture ratio of 1.15. This unit was projected to weight 163 kg (360 lbm).

The total propellant required by this APU is determined by summing all the work supplied by the electric motors during the mission. This work is determined to be 83.4 kWh (112 hph) which requires 92 kg (203 lbm) of propellant.

The weight of the APU has not been added to the dry weight of the auxiliary propulsion system because this system is assumed to be available on an all electric vehicle. The propellant consumed by the APU would diminish the vehicle reserves upon landing but is felt to be within the accuracy of the calculation.

SUMMARY OF RESULTS

This system study of the scavenging of hydrogen and oxygen propellants from the launch propulsion system of a Shuttle II vehicle on a Space Station rendezvous mission is driven by two basic reasons:

1. A vehicle payload benefit is gained by utilizing the launch propulsion system reserves and residuals for auxiliary propulsion and by the use of higher specific impulse propellants than the state-of-the-art Earth-storable propellants.

2. Operations are simplified by the use of a common propellant in the launch and auxiliary propulsion systems and by the use of nontoxic, noncorrosive propellants.

This paper addresses the first reason only, by conducting a detailed weight analysis of a propellant scavenging and auxiliary propulsion system which operates on the propellants in the cryogenic state. No propellant heating equipment with its associated weight and system performance penalties is utilized, since auxiliary propulsion thrusters have been demonstrated to operate on cryogenic hydrogen and oxygen. The assumption is made that OMS impulse requirements are met by simultaneously firing primary RCS thrusters at the weight penalty of adding 8 additional thrusters. Vernier RCS thrusters provide the on-orbit attitude control and are supplied with low pressure gaseous propellants by using the launch propulsion tanks as blow down gas storage. This weight analysis indicates that by utilizing this scavenging auxiliary propulsion system, the Shuttle II vehicle can deliver an additional 7820 kg (17 241 lbm) to the Space Station for the same launch propulsion system.

APPENDIX A

BASIS FOR DETAILED WEIGHT ANALYSIS

Item 1. Primary RCS Thrusters (4450 N, 1000 lbf class)

Liquid hydrogen/liquid oxygen thrusters of the type required for this vehicle have been demonstrated to have a specific impulse of 427 sec (ref. 9) at a mixture ratio of 4.5 (weight of oxygen/weight of hydrogen). The thruster was designed with a doublet injector on a film-cooled Columbian chamber much the same as the Earth-storable bipropellant thruster on the present Shuttle. However, a flight weight version of the thruster was never developed. The best estimate of the weight of this component, including four valves, is therefore determined from the flight weight thrusters on the present shuttle (ref. 12). This weight is 7.26 kg (16 lbf) for the thruster plus 0.771 kg (1.7 lbf) for each valve for a weight of 10.4 kg (22.9 lbf) per unit. The quantity of thrusters required is set at the quantity on the present shuttle (38) plus eight additional thrusters in the aft direction for orbital maneuver system level impulse as discussed in the previous section. The total quantity is, therefore, 46 and the total weight of these thrusters is then 477.6 kg (1053 lbf).

Item 2. Vernier RCS Thrusters (111 N, 25 lbf class)

Low chamber pressure thrusters of the 6673 N (1500 lbf) class have been demonstrated by NASA Contractors to have a specific impulse of 382 sec at a mixture of 2.5 (ref. 6). These thrusters are quite large due to the low density of the propellants. Physically scaling this thruster design down to a 111 N (25 lbf) class is not felt to be a problem. In fact, this thruster is felt to be of the same physical size as the primary RCS thrusters and with a little plumbing some of the primary RCS thrusters could be designed to operate in a "dual state" (ref. 6) mode, i.e., high pressure liquid propellants and low pressure gaseous propellants. This thruster concept remains to be demonstrated. The weight of this component, including four valves, is therefore added to the system at a weight of 10.4 kg (22.9 lbf) per unit. The quantity of thrusters required is set at the quantity on the present shuttle (six). The total weight of these thrusters is then 62.1 kg (137 lbf).

Item 3. LH₂ Manifold Line

These manifold lines run in a loop of ~90 percent of the length and width of the vehicle in figure 1. This length of line is estimated to be ~110 m (360 ft). The flow rate used to size the pipe is that required to run 6 primary RCS thrusters simultaneously (1.20 kg/sec, 2.65 lbf/sec). The tubing is 2219 aluminum, 3.175 cm (1.25 in.) diameter, 0.239 cm (0.094 in.) thick wall and is designed for 6900 kPa (1000 psia). The maximum possible pressure drop in the line occurs at 3450 kPa (500 psia), 278 K (500 °R) and is 109 kPa/m (4.81 psia/ft). A dual system is provided for fail-return operation of the vehicle by having a quantity of two of these lines with each servicing half of the primary thrusters. Each line has an estimated weight of 73.0 kg (161 lbf) based on the density of 2219 aluminum for a total weight for this item of 146.1 kg (322 lbf).

Item 4. LH₂ Expansion Bellows.

When heat soaks into the liquid manifolds, propellant expands into expansion bellows. Helium gas is utilized for the expansion and contraction of the bellows. When the bellows is contracted, the manifold is at cryogenic temperature and 3450 kPa (500 psia) pressure. When the bellows is fully expanded, the manifold is at 278 K (500 °R) and 6900 kPa (1000 psia). The volume of the propellant compartments of the bellows is calculated as the total liquid manifold volume multiplied by the ratio of propellant density between expanded and contracted positions. This is 12 times the manifold volume for the propellant compartments volume. The helium compartment is equal to the propellant compartment volume assuming isothermal compression of the helium. The total bellows pressure vessel volume requirement, then, is calculated as 24 times the LH₂ manifold volume. One bellows is required for each manifold for a total of two, each with a volume of 2.08 m³ (73.4 ft³). Assuming a cylindrical tank with length equal to diameter, the diameter of this bellows is 1.38 m (4.54 ft). Tank weight is determined to be 279.9 kg (617 lbm) from data on existing spherical tanks (ref. 13) operating at 6900 kPa (1000 psia) pressure and a factor of safety of 2. The total weight of the bellows is 559.7 kg (1234 lbm).

Item 5. He Gas - LH₂ Bellows.

The mass of helium required in each of the bellows is determined at the bellows expanded condition i.e., pressure (6900 kPa, 1000 psia), temperature (278 K, 500 °R) and volume (1.041 m³, 36.7 ft³). This mass is 12.5 kg (27.5 lbm) for each bellows and is 24.9 kg (55.0 lbm) total.

Item 6. LO₂ Manifold Line.

The LO₂ manifold line is the same size as the LH₂ manifold line (Item 3). The flow rate used to determine the pressure drop in the line is that required to run six primary RCS thrusters simultaneously (5.40 kg/sec, 11.9 lbm/sec). This pressure drop is 124.4 kPa/m (5.50 psia/ft) of line. A dual system is provided for fail-return operation of the vehicle by having a quantity of two of these lines with each servicing half of the thrusters. Each line has an estimated weight of 73.0 kg (161 lbm) for a total weight for this item of 146.1 kg (322 lbm).

Item 7. LO₂ Expansion Bellows.

The LO₂ expansion bellows is sized in the same manner as the LH₂ expansion bellows (Item 4). When the bellows is contracted, the manifold is at cryogenic temperature and 3450 kPa (500 psia) pressure. When the bellows is fully expanded, the manifold is at space ambient temperature (278 K, 500 °R) and 6900 kPa (1000 psia). The volume of the propellant compartment of the bellows is 10 times the volume of the LO₂ manifold. The entire pressure vessel volume, including the helium compartment, is then 20 times the manifold volume assuming isothermal compression of the helium. The bellows pressure vessel volume for is 1.74 m³ (61.4 ft³) for each manifold. Assuming a cylindrical tank with length equal to diameter, the diameter of this bellows is 1.30 m (4.27 ft). The tank weight is determined the same way as Item 4. This weight is 233.6 kg (515 lbm) for each bellows for a total weight of 467.2 kg (1030 lbm) for this item.

Item 8. He Gas - LO₂ Bellows.

The mass of helium required for each bellows is determined the same way as for Item 5. This is 10.4 kg (23 lbm) for each bellows and 20.9 (46 lbm) for this item.

Item 9. High Pressure LH₂ Pump and Motor.

The total LH₂ pump flow rate for each manifold is chosen to be that required to run six primary RCS thrusters simultaneously. This total flow (1.20 kg/sec, 2.65 lbm/sec) is divided equally among three pumps for a pump flow rate of 0.40 kg/sec (0.89 lbm/sec). Pump weight information is derived from single stage centrifugal pump parametric data (ref. 14) and each pump is determined to weigh 1.27 kg (2.8 lbm) and requires 13.6 kW (18.2 hp) to operate. The total of six pumps for the two manifolds weighs 7.62 kg (16.8 lbm). These pumps are to be driven by electric motors and low weight motors of this power rating have been developed (ref. 15). They are reported to weigh 7.80 kg (17.2 lbm). The total of 6 motors for the 6 pumps weighs 46.8 kg (103.2 lbm). The total weight for this item is then 54.4 kg (120 lbm).

Item 10. High Pressure LO₂ Pump and Motor

The total LO₂ pump flow rate for each manifold is chosen to be that required to run six primary RCS thrusters simultaneously. This total flow (5.40 kg/sec, 11.9 lbm/sec) is divided equally among the three pumps for a pump flow rate of 1.80 kg/sec (3.97 lbm/sec). Pump weight information is derived from two-stage centrifugal pump parametric data (ref. 14) and each pump is determined to weigh 0.227 kg (0.5 lbm) and requires 13.4 kW (18.0 hp) to operate. These pumps are driven by low weight electric motors (ref. 15) which each weigh 7.80 kg (17.2 lbm) for a pump plus motor weight of 8.03 kg (17.7 lbm). The total weight for this item is then 48.1 kg (106 lbm).

Item 11. LH₂ Accumulator.

One LH₂ accumulator is assumed for each manifold distribution system. This accumulator is assumed to use the insulation technology developed for the Power Reactant Storage Assembly (PRSA) tanks on the current shuttle. Each accumulator is sized to contain 619.6 kg (1366 lbm) of LH₂ at a pressure of 173 kPa (25 psia) and a temperature of 22.2 K (40 °R). Each accumulator has a volume of 9.14 m³ (323 ft³) and an inside diameter of 2.60 m (8.53 ft). Tank weight is estimated to be 308 kg (679 lbm) based on PRSA weight (ref. 16) information. The total weight for this item is then 616 kg (1358 lbm).

Item 12. LH₂ Accumulator Subcooler.

Thermal subcoolers were studied as a way of insuring that only liquid is transferred from a tank. In the subcooler system, propellant is withdrawn from a tank, throttled to a lower pressure and passed through the subcooler. The propellant to be transferred is also passed through the subcooler, giving off heat to the throttled propellant. Parametric weight information for these subcoolers is used to estimate a weight of 23.7 kg (52.3 lbm) for each. The total weight of six for both accumulators is 142.4 kg (314 lbm).

Item 13. LH₂ Accumulator Compressor.

A compressor is added for each subcooler to bring the throttled propellant back to its original pressure and return it to the tank. The single-stage, bellows gas pump (ref. 17) has a 2.6:1 compression ratio and weighs 3.18 kg (7 lbm). Six of these are required for a total weight for this item of 19.1 kg (42.0 lbm).

Item 14. LH₂ Scavenging Pump and Motor.

The scavenging pumps are sized to scavenge at the total rate of 2.40 kg/sec (5.30 lbm/sec) needed to resupply the accumulators during orbital maneuvers. A quantity of eight of these pumps is chosen because of flowrate limitations of the thermal subcoolers (Item 15). Each pump is a single stage centrifugal pump with a flowrate of 0.30 kg/sec (0.663 lbm/sec) and is estimated to weigh (ref. 14) 1.36 kg (3.0 lbm) and to require 9.9 kW (13.4 hp) to operate. These pumps are driven by low weight electric motors (ref. 15) which each weigh 7.80 kg (17.2 lbm). The total pump plus motor weight is then 9.16 kg (20.2 lbm). The total weight of eight pumps is then 73.5 kg (162 lbm).

Item 15. LH₂ Scavenging Subcooler.

Parametric data on these subcoolers (ref. 7) indicates a maximum flowrate of only 0.30 kg/sec (0.663 lbm/sec). Therefore, a total of eight subcoolers is required to deliver the required flowrate of 2.40 kg/sec (5.30 lbm/sec). The estimated weight for each subcooler is 13.8 kg (30.4 lbm) and the total weight is then 110.2 kg (243 lbm).

Item 16. LH₂ Scavenging Compressor.

This item is assumed to be the same as Item 13 which is 3.18 kg (7.0 lbm). A total of eight of these compressors gives a total weight of 25.4 kg (56.0 lbm).

Item 17. LO₂ Accumulator.

One LO₂ accumulator is assumed for each manifold distribution system. This accumulator is assumed to use the insulation technology developed for the PRSA tanks on the present shuttle. Each accumulator is sized to contain 2453 kg (5408 lbm) of LO₂ at a pressure of 207 kPa (30 psia) and a temperature of 97.8 K (176 °R). Each accumulator has a volume of 2.25 m³ (79.4 ft³) and an inside diameter of 1.63 m (5.33 ft). The tank weight is estimated to be 83.0 kg (183 lbm) based on PRSA weight (ref. 16) information. The total weight for this item is then 166 kg (366 lbm).

Item 18. LO₂ Accumulator Subcooler.

These subcoolers are sized for a flowrate of 1.80 kg/sec (3.97 lbm/sec) which is matched to the high pressure LO₂ pump (Item 10). Parametric weight information (ref. 7) is used to estimate a weight of 11.0 kg (24.3 lbm) for each subcooler. The total of six subcoolers gives a total weight of 66.2 kg (146 lbm).

Item 19. LO₂ Accumulator Compressor

This item is assumed to be the same as Item 13, which has a weight of 3.18 kg (7.0 lbm). The total of six of these compressors gives a total weight of 19.1 kg (42.0 lbm).

Item 20. LO₂ Scavenging Pump and Motor.

These scavenging pumps are sized to scavenge at the total rate of 10.8 kg/sec (23.8 lbm/sec) needed to resupply the accumulators during orbital maneuvers. A quantity of eight of these pumps is chosen because of flowrate limitations of the thermal subcoolers (Item 21). Each pump is a two-stage centrifugal pump with a flowrate of 1.35 kg/sec (2.98 lbm/sec) and is estimated to weigh 0.680 kg (1.5 lbm) and to require 14.5 kW (19.4 hp) to operate. These pumps are driven by low weight electric motors (ref. 15) which weigh 7.80 kg (17.2 lbm) each. The pump plus motor weight is then 8.48 kg (18.7 lbm). The total weight of eight pumps is then 68.0 (150 lbm).

Item 21. LO₂ Scavenging Subcooler.

These subcoolers are required to deliver 10.8 kg/sec (23.8 lbm/sec) of LO₂ to resupply the accumulators during orbital maneuvers. A quantity of eight is chosen to reduce the flowrate of each to 1.35 kg/sec (2.98 lbm/sec) and to avoid exceeding the maximum flowrate. The estimated weight for each subcooler is 9.48 kg (20.9 lbm) and the total weight is then 75.7 kg (167 lbm).

Item 22. LO₂ Scavenging Compressor.

This item is assumed to be the same as Item 13, which has a weight of 3.18 kg (7.0 lbm). The total of eight of these compressors gives a total weight of 25.4 kg (56.0 lbm).

Item 23. LH₂ Manifold Circulation Pump.

This item is estimated to weigh 0.227 kg (0.5 lbm) and is used to circulate LH₂ throughout the LH₂ manifolds to keep the manifold at a uniform temperature.

Item 24. LO₂ Manifold Circulation Pump.

This item is estimated to weigh 0.454 kg (1.0 lbm) and is used to circulate LO₂ throughout the LO₂ manifolds to keep the manifold at a uniform temperature.

Item 25. GH₂ Distribution Line.

The gas distribution lines run ~90 percent of the length and width of the vehicle in figure 1. This length of line is estimated to be ~55 m (180 ft). The flow rate used to size the pipe is that required to run two vernier RCS thrusters simultaneously (0.017 kg/sec, 0.037 lbm/sec). The tubing is 2219 aluminum, 3.81 cm (1.5 in.) diameter, 0.051 cm (0.020 in.) thick wall and is designed for 173 kPa (25 psia). The maximum pressure drop in the line occurs at 69 kPa (10 psia) and 278 K (500 °R) and is 0.951 kPa/m (0.042 psia/ft) of line. A dual system is provided for fail-return operation of the vehicle by

having a quantity of two of these lines with each servicing three of the vernier thrusters. Each line has an estimated weight of 9.53 kg (21 lbm) based on the density of 2219 aluminum for a total weight for this item of 19.1 kg (42 lbm).

Item 26. GO₂ Distribution Line.

The GO₂ distribution line is the same size as the GH₂ distribution line (Item 25). The flow rate used to determine the pressure drop in the line is that required to run two vernier RCS thrusters simultaneously (0.042 kg/sec, 0.093 lbm/sec). This pressure drop is 0.271 kPa/m (0.012 psia/ft) of line. A dual system is provided for fail-return operation of the vehicle by having a quantity of two of these lines with each servicing three of the thrusters. Each line has an estimated weight of 9.53 kg (21 lbm) for a total weight for this item of 19.1 kg (42 lbm).

REFERENCES

1. Freeman, D.C. Jr.: The New Space Transportation Begins Today. *Astronaut. Aeronaut.*, vol. 21, no. 6, June 1983, pp. 36-37,48.
2. Wilhite, A.W., et al.: Booster and Orbiter Configurations. *Astronaut. Aeronaut.*, vol. 21, no. 6, June 1983, pp. 38-42
3. Taylor, T.A., et al.: Designing for a New Era of Launch Vehicle Operational Efficiency. *Astronaut. Aeronaut.*, vol. 21, no. 6, June 1983, pp. 44-48
4. Taylor, A.H., et al.: Structures and Subsystems. *Astronaut. Aeronaut.*, vol. 21, no. 6, June 1983, pp. 50-56,62.
5. Space Shuttle Mass Properties Status Report. Rockwell International, Space Division Report SD72-SL-0120-18, Mar. 1974.
6. Schneider, S.J.: Auxiliary Propulsion Technology for Advanced Earth-to-Orbit Vehicles. NASA TM-100237, 1987.
7. Merino, F., et al.: Low-Thrust Chemical Propulsion System Propellant Expulsion and Thermal Conditioning Study. (GDC-NAS-82-002, General Dynamics Convair Division; NASA Contract NAS3-22650), NASA-CR-167841, 1982.
8. Akkerman, J.W.: Shuttle Reaction Control System Cryogenic Liquid Distribution System Study. NASA TM X-68913, 1972.
9. Blubaugh, A.L.; and Schoenman, L.: Extended Temperature Range ACPS Thruster Investigation. NASA CR-134655, 1974.
10. Kendall, A.S.; McKee, H.B.; and Orton, G.F.: Space Shuttle Low Pressure Auxiliary Propulsion Subsystem Design Definition. (MDC-E0303, McDonnell Douglas Astronautics Co.; NASA Contract NAS9-11012) NASA-CR-114999, 1971.
11. Harris, E.: Design of H₂-O₂ Space Shuttle APU. (AIRESEARCH-74-9874-PT-1, AiResearch Manufacturing Co.; NASA Contract NAS3-15708), NASA CR-121214, 1974.

12. Orbiter Detail Weight Statement. SD75-SH-0116-97, Rockwell International, Shuttle Orbiter Division, Sept. 1983.
13. Wagner, W.A.; and Keller, R.B.: Liquid Rocket Metal Tanks and Tank Components. NASA-SP-8088, 1974.
14. Benson, R.A.; Burge, H.L.; and Shaffer, A.: Space Shuttle High Pressure Auxiliary Propulsion, Subsystem Definition. NASA CR-115162, 1971.
15. Edge, J.T.: An Electromechanical Actuator Technology Development Program. SAE Paper 780581, Apr. 1978.
16. Shuttle Operational Data Book. JSC-08934, NASA Johnson Space Center, Aug. 1980.
17. Bader, C.H.: Component Data Base for Space Station Resistojet Auxiliary Propulsion. NASA CR-180834, 1988.

TABLE I. - MISSION EVENTS AND AUXILIARY PROPULSION REQUIREMENTS FOR THE SHUTTLE II VEHICLE ON A SPACE STATION RENDEZVOUS MISSION

Event number	Description	Time for event, sec	Time, sec	Change in velocity, m/sec (ft/sec)	Propellant, kg (lbm)
1	50x100 nm insertion, MECO	-----	0	-----	-----
2	45 min delay	2700	2700	0	0
3	100x100 nm circularization	51	2751	27.7 (91)	654 (1442)
4	10 min phasing period	600	3351	0	0
5	100x262 nm insertion	160	3511	86.6 (284)	2014 (4440)
6	45 min time delay	2700	6211	0	0
7	262x262 nm circularization	154	6365	85.6 (281)	1953 (4305)
8	10 min closure and dock	600	6965	11.6 (38)	261 (575)
9	72 hr orbit maintenance	259200	266165	33.5 (110)	840 (1851)
10	De-orbit	6361	272526	212 (696)	4563 (10059)
			Totals	457 (1500)	10284 (22672)

TABLE II. - PROPELLANT MANAGEMENT OF MAIN TANK RESIDUALS AND RESERVES DURING EVENTS OF TABLE I.

[Vehicle dry weight, 85 275 kg; heat rate to main tank, 53.8 kW; accumulator launched 60 percent full; hydrogen required for mission, 1957 kg; mission reserve, 409 kg or 20.9 percent; hydrogen scavenged for propulsion, 1213 kg; hydrogen lost, 1099 kg.]

(a) Hydrogen - SI Units

Event number	M _{tot} , kg	M _{liq} , kg	M _{vap} , kg	x	P, kPa	T, K	M _{acc} , kg	M _{scav} , kg	M _{lost} , kg	M _{orbit} , kg	
1	2722	2527	194	0.0713	7.66	13.9	744	0	0	99 090	
2	2227	1990	236	.106	10.4	14.4	1239	495	↓	99 090	
3	2108	1867	240	.114	10.4	14.4	↓	119	↓	98 436	
4	2108	1794	314	.149	13.8	15.0	↓	0	↓	98 436	
5	1742	1418	324	.186	13.8	15.0	↓	366	↓	96 422	
6	1742	1101	641	.368	29.0	16.7	↓	0	↓	96 422	
7	1387	735	652	.470	29.0	16.7	↓	355	↓	94 469	
8	1339	581	758	.566	36.2	17.2	↓	48	↓	94 208	
9	90	0	90	1.0	69.0	278.0	↓	240	1009	92 360	
10	Vented and Inerted						↓	409	0	90	86 857

TABLE II. - Continued.

[Vehicle dry weight, 188 000 lbm; heat rate to main tank, 183 589 Btu/hr; accumulator launched 60 percent full; hydrogen required for mission, 4315 lbm; mission reserve, 902 lbm or 20.9 percent; hydrogen scavenged for propulsion, 2675 lbm; hydrogen lost, 2423 lbm.]

(a) Concluded - English units

Event number	M _{tot} , lbm	M _{liq} , lbm	M _{vap} , lbm	x	P, psia	T, °R	M _{acc} , lbm	M _{scav} , lbm	M _{lost} , lbm	M _{orbit} , lbm	
1	6000	5572	428	0.0713	1.11	25	1640	0	0	218 456	
2	4909	4388	521	.106	1.50	26	2731	1091	↓	218 456	
3	4647	4117	530	.114	1.50	26	↓	262	↓	217 014	
4	4647	3954	693	.149	2.00	27	↓	0	↓	217 014	
5	3840	3126	714	.186	2.00	27	↓	807	↓	212 574	
6	3840	2427	1413	.368	4.21	30	↓	0	↓	212 574	
7	3057	1620	1437	.470	4.21	30	↓	783	↓	208 269	
8	2952	1281	1671	.566	5.25	31	↓	105	↓	207 694	
9	198	0	198	1.0	10.0	500	↓	529	2225	203 618	
10	Vented and Inerted						↓	902	0	198	191 488

TABLE II. - Continued.

[Vehicle dry weight, 85 275 kg; heat rate to main tank, 13.7 kW; accumulator launched 100 percent full; oxygen required for mission, 8327 kg; mission reserve, 1173 kg or 14.1 percent; oxygen scavenged for propulsion, 3421 kg; oxygen lost, 850 kg.]

(b) Oxygen - SI units

Event number	M _{tot} , kg	M _{liq} , kg	M _{vap} , kg	x	P, kPa	T, K	M _{acc} , kg	M _{scav} , kg	M _{lost} , kg	M _{orbit} , kg
1	5443	4992	451	0.0829	15.8	75.6	4906	0	0	99 090
2	5443	4888	555	.102	18.7	76.7	↓	0	↓	99 090
3	4908	4329	579	.118	22.0	77.8		535		98 436
4	4908	4309	599	.122	22.0	77.8		0		98 436
5	3260	2657	603	.185	22.0	77.8		1648		96 422
6	3260	2527	733	.225	25.8	78.9		0		96 422
7	1662	860	803	.483	30.1	80.0		1598		94 469
8	1442	632	817	.564	30.1	80.0		213		94 208
9	850	0	850	1.0	111.7	278.0		600		92 360
10	Vented and Inerted							1173		0

TABLE II. - Concluded.

[Vehicle dry weight, 188 000 lbm; heat rate to main tank, 46 756 Btu/hr; accumulator launched 100 percent full; oxygen required for mission, 18 357 lbm; mission reserve, 2586 lbm or 14.1 percent; oxygen scavenged for propulsion, 7541 lbm; oxygen lost, 1873 lbm.]

(b) Concluded - English units

Event number	M _{tot} , lbm	M _{liq} , lbm	M _{vap} , lbm	x	P, psia	T, °R	M _{acc} , lbm	M _{scav} , lbm	M _{lost} , lbm	M _{orbit} , lbm
1	12 000	11 005	995	0.0829	2.29	136	10 816	0	0	218 456
2	12 000	10 776	1224	.102	2.71	138	↓	0	↓	218 456
3	10 820	9 543	1277	.118	3.19	140		1180		217 014
4	10 820	9 500	1320	.122	3.19	140		0		217 014
5	7 187	5 857	1330	.185	3.19	140		3633		212 574
6	7 187	5 570	1617	.225	3.74	142		0		212 574
7	3 665	1 895	1770	.483	4.36	144		3522		208 269
8	3 195	1 393	1802	.564	4.36	144		470		207 694
9	1 873	0	1873	1.0	16.2	500		1322		203 618
10	Vented and Inerted							2 586		0

TABLE III. - DETAILED WEIGHT ANALYSIS OF AUXILIARY PROPULSION, SCAVENGING AND DISTRIBUTION SYSTEM ITEMS OF FIGURE 4.

Item	Description	Quantity	Weight/unit, kg (lbf)	Weight, kg (lbf)
1	Primary RCS thrusters	46	10.4 (22.9)	477.6 (1053)
2	Vernier RCS thrusters	6	10.4 (22.9)	62.1 (137)
3	LH ₂ manifold line	2	73.0 (161)	146.1 (322)
4	LH ₂ expansion bellows	1	279.9 (617)	599.7 (1234)
5	He gas -- LH ₂ bellows	1	12.5 (27.5)	24.9 (55.0)
6	LO ₂ manifold line	1	73.0 (161)	146.1 (322)
7	LO ₂ expansion bellows	1	233.6 (515)	467.0 (1030)
8	He gas -- LO ₂ bellows	1	10.4 (23)	20.9 (46)
9	High pressure LH ₂ pump and motor	6	9.07 (20)	54.4 (120)
			13.7 kW (18.4 hp)	82.2 kW (110.4 hp)
10	High pressure LO ₂ pump and motor	6	8.03 (17.7)	48.1 (106)
			13.4 kW (18.0 hp)	80.4 kW (108.0 hp)
11	LH ₂ accumulator	2	308.0 (679)	616.0 (1358)
12	LH ₂ accumulator subcooler	6	23.7 (52.3)	142.4 (314)
			3.18 (7.0)	19.1 (42.0)
13	LH ₂ accumulator compressor	6	0.28 kW (0.38 hp)	1.68 kW (2.28 hp)
14	LH ₂ scavenging pump and motor	8	9.16 (20.2)	73.5 (162)
			10.0 kW (13.4 hp)	80.0 kW (107.2 hp)
15	LH ₂ scavenging subcooler	8	13.8 (30.4)	110.2 (243)
16	LH ₂ scavenging compressor	8	3.18 (7.0)	25.4 (56.0)
			0.28 kW (0.38 hp)	2.24 kW (3.04 hp)
17	LO ₂ accumulator	2	83.0 (183)	166.0 (356)
18	LO ₂ accumulator subcooler	6	11.0 (24.3)	66.2 (146)
19	LO ₂ accumulator compressor	6	3.18 (7.0)	19.1 (42.0)
			0.28 kW (0.38 hp)	1.68 kW (2.28 hp)
20	LO ₂ scavenging pump and motor	8	8.48 (18.7)	68.0 (150)
			14.5 kW (19.4 hp)	115.0 kW (155.2 hp)
21	LO ₂ scavenging subcooler	8	9.48 (20.9)	75.7 (167)
22	LO ₂ scavenging compressor	8	3.18 (7.0)	25.4 (56.0)
			0.28 kW (0.38 hp)	2.24 kW (3.04 hp)
23	LH ₂ manifold circulation pump	2	0.227 (0.5)	0.454 (1.0)
			0.0745 kW (0.10 hp)	0.149 kW (0.20 hp)
24	LO ₂ manifold circulation pump	2	0.454 (1.0)	0.907 (2.0)
			0.15 kW (0.202 hp)	0.30 kW (0.404 hp)
25	GH ₂ distribution line	2	9.53 (21)	19.1 (42)
26	GO ₂ distribution line	2	9.53 (21)	19.1 (42)
			Subtotal	3454 kg (7614 lb)
Electrical cabling (5 percent subtotal) (ref. 5)				173 kg (381 lbf)
Secondary structure support hardware (20 percent subtotal) (ref. 5)				691 kg (1523 lbf)
			Subtotal	4317 kg (9518 lbf)
Advanced vehicle weight growth margin (10 percent subtotal)				432 kg (952 lbf)
			Total APS weight	4749 kg (10470 lbf)

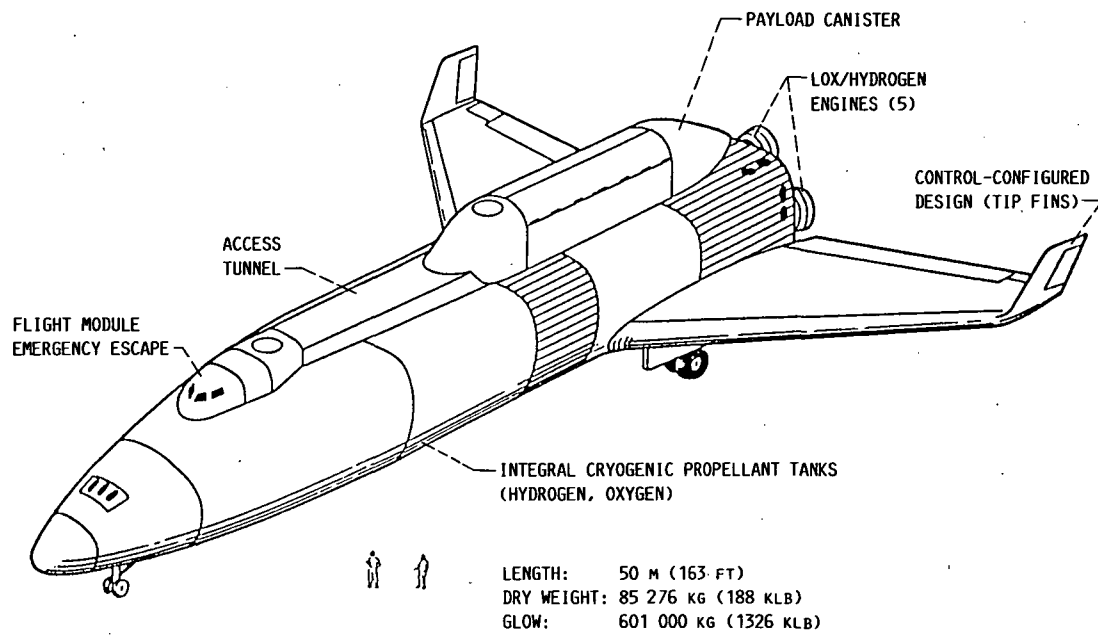

FIGURE 1. - VERSION OF SHUTTLE II ORBITER CHOSEN FOR ANALYSIS IN THIS STUDY.

ORIGINAL PAGE IS
OF POOR QUALITY

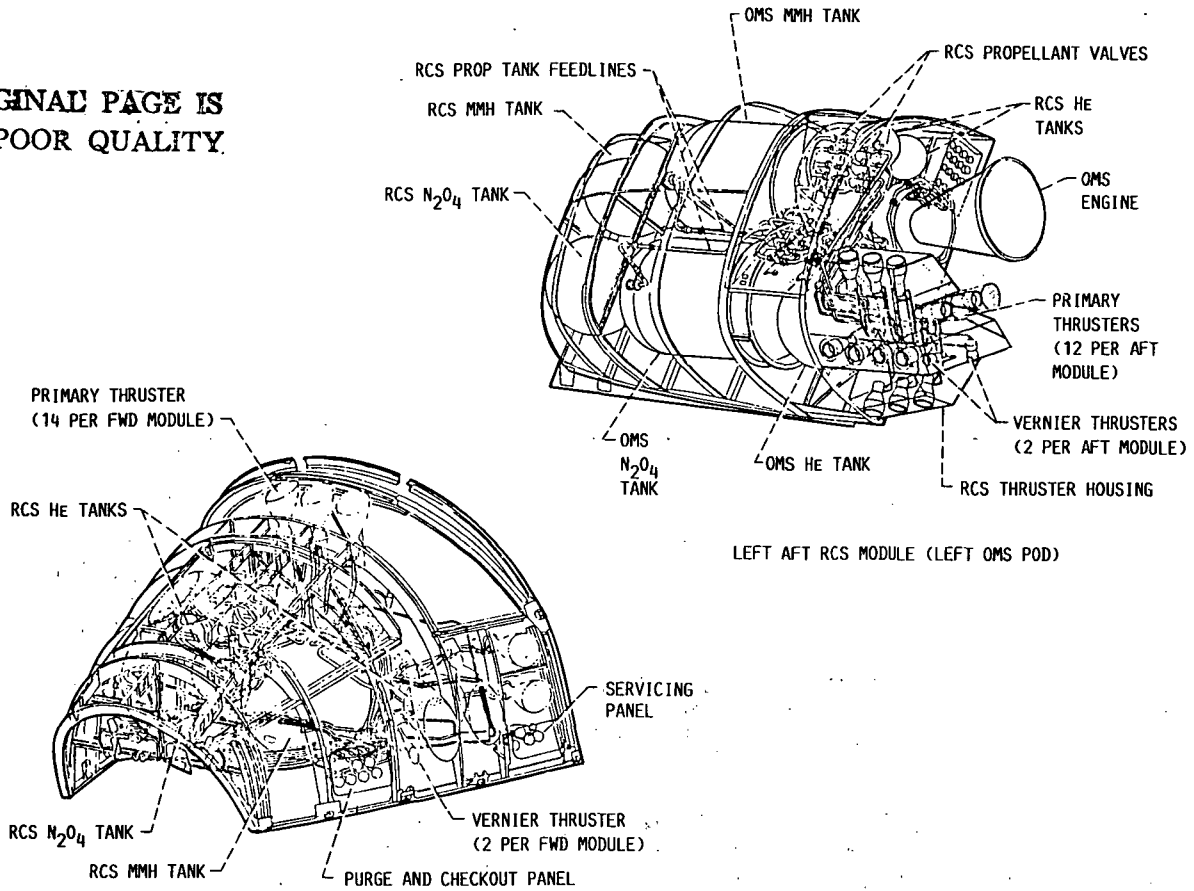

FIGURE 2. - CURRENT SHUTTLE OMS AND RCS SUBSYSTEMS FOR REFERENCE AND COMPARISON.

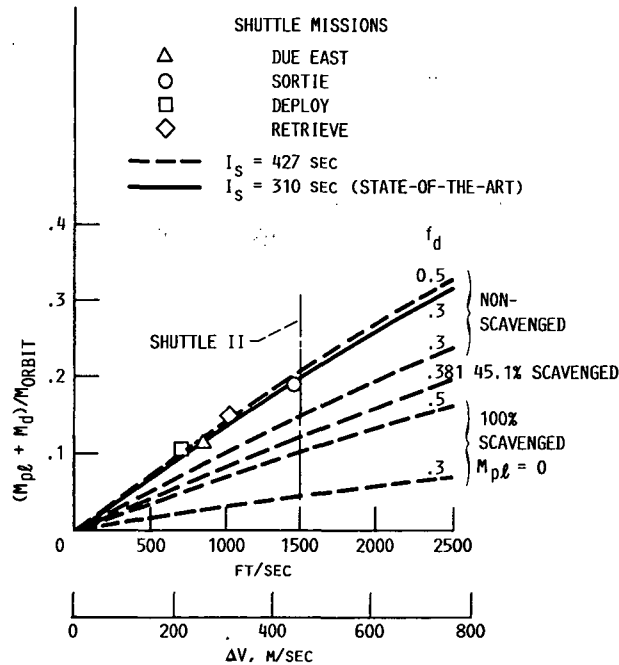

FIGURE 3. - ON-ORBIT VEHICLE MASS FRACTION REQUIRED BY THE AUXILIARY PROPULSION SYSTEM VERSUS AUXILIARY PROPULSION SYSTEM ΔV AS A FUNCTION OF DRY MASS FRACTION OF THE AUXILIARY PROPULSION SYSTEM.

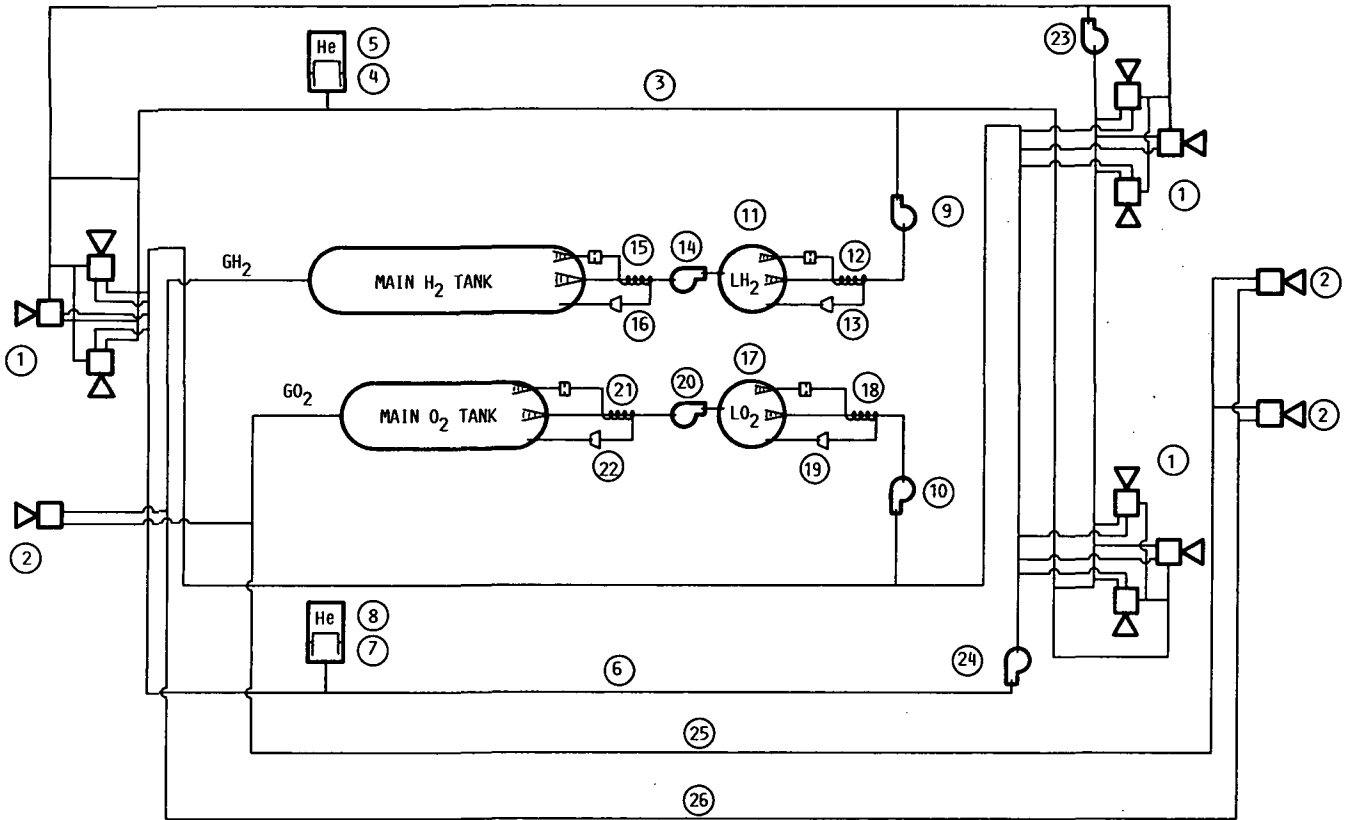

FIGURE 4. - PROPELLANT MANAGEMENT SYSTEM FOR SCAVENGING PROPELLANT ON ADVANCED AEROSPACE VEHICLES.

1. Report No. NASA TM-100900 SAWE Paper No. 1818		2. Government Accession No.		3. Recipient's Catalog No.	
4. Title and Subtitle Weight Savings in Aerospace Vehicles Through Propellant Scavenging				5. Report Date	
				6. Performing Organization Code	
7. Author(s) Steven J. Schneider and Brian D. Reed				8. Performing Organization Report No. E-4079	
				10. Work Unit No. 506-42-31	
9. Performing Organization Name and Address National Aeronautics and Space Administration Lewis Research Center Cleveland, Ohio 44135-3191				11. Contract or Grant No.	
				13. Type of Report and Period Covered Technical Memorandum	
12. Sponsoring Agency Name and Address National Aeronautics and Space Administration Washington, D.C. 20546-0001				14. Sponsoring Agency Code	
15. Supplementary Notes Prepared for the 47th Annual Conference on Mass Properties Engineering sponsored by the Society of Allied Weight Engineers, Inc., Plymouth, Michigan, May 23-25, 1988.					
16. Abstract Two basic reasons exist for studying propellant scavenging in aerospace vehicles. First of all, a vehicle payload benefit is gained by utilizing the launch propulsion system reserves and residuals for auxiliary propulsion. Second, the use of a common propellant in the launch and auxiliary propulsion systems simplifies operations and logistics since only one propellant system needs to be serviced. Also, the propellants most probably available for scavenging are hydrogen and oxygen and the use of these propellants for auxiliary propulsion has two additional basic advantages over the use of state-of-the-art Earth-storable propellants. A vehicle payload benefit is gained by utilizing higher specific impulse propellants and hydrogen and oxygen offer the benefits of nontoxic, noncorrosive propellants. This paper addresses the vehicle payload benefits of scavenging hydrogen and oxygen propellants. The approach used is to select a vehicle and a mission and then select a scavenging system for detailed weight analysis. The Shuttle II vehicle on a Space Station rendezvous mission is chosen for study. The propellant scavenging system scavenges liquid hydrogen and liquid oxygen from the launch propulsion tankage during orbital maneuvers and stores them in well-insulated liquid accumulators for use in a cryogenic auxiliary propulsion system. The fraction of auxiliary propulsion propellant which may be scavenged for propulsive purposes is estimated to be 45.1 percent. The auxiliary propulsion subsystem dry mass, including the proposed scavenging system, an additional 20 percent for secondary structure, an additional 5 percent for electrical service, a 10 percent weight growth margin, and 15.4 percent propellant reserves and residuals is estimated to be 6331 kg (13 958 lbm). This study shows that the fraction of the on-orbit vehicle mass required by the auxiliary propulsion system of this Shuttle II vehicle using this technology is estimated to be 12.0 percent compared to 19.9 percent for a vehicle with an Earth-storable bipropellant system. This results in a vehicle with the capability of delivering an additional 7820 kg (17 241 lbm) to the Space Station.					
17. Key Words (Suggested by Author(s)) Aerospace vehicles; Integrated propulsion; Propellant scavenging; System weight; Cryogenic propellants; Auxiliary propulsion			18. Distribution Statement Unclassified - Unlimited Subject Category 15		
19. Security Classif. (of this report) Unclassified		20. Security Classif. (of this page) Unclassified		21. No of pages 24	22. Price* A02

National Aeronautics and
Space Administration

Lewis Research Center
Cleveland, Ohio 44135

Official Business
Penalty for Private Use \$300

FOURTH CLASS MAIL

ADDRESS CORRECTION REQUESTED



Postage and Fees Paid
National Aeronautics and
Space Administration
NASA 451

NASA
