

N88 - 25682**NASA'S MOBILE SATELLITE DEVELOPMENT PROGRAM**

DR. WILLIAM RAFFERTY, Jet Propulsion Laboratory, United States;
DR. KHALED DESSOUKY, Telos Aerospace Systems, United States;
MILES SUE, Jet Propulsion Laboratory, United States.

JET PROPULSION LABORATORY
California Institute of Technology
4800 Oak Grove Drive 238-420
Pasadena, California 91109
United States

ABSTRACT

A Mobile Satellite System (MSS) will provide data and voice communications over a vast geographical area to a large population of mobile users. This paper provides a technical overview of the extensive research and technology studies and developments performed under NASA's mobile satellite program (MSAT-X) in support of the introduction of a U.S. MSS. The paper emphasizes the critical technologies necessary to enable such a system: vehicle antennas, modulation and coding, speech coders, networking and propagation characterization. Also proposed is a first, and future, generation MSS architecture based upon realized ground segment equipment and advanced space segment studies.

1. INTRODUCTION

NASA's involvement in mobile satellite communications can be traced back to the late 1970's. Around that time, NASA initiated system feasibility studies culminating in land mobile field tests using trucks and the ATS-6 experimental satellite. The studies and tests demonstrated the practicality of such a satellite link and were subsequently followed by market studies which led to the petitioning of the FCC by NASA for a mobile satellite system (MSS) frequency allocation in the UHF band. The NASA petition, and its active advocacy of MSS, then generated much interest in the private sector which resulted in the filing for developmental MSS licenses, and the eventual formation of a U.S. MSS Consortium.

In 1983, the Jet Propulsion Laboratory was designated by NASA as the lead center for MSS studies and critical technology identification and development under the Mobile Satellite Experiment (MSAT-X) program. Through this program it is intended to develop and demonstrate advanced ground and space segment technology to accelerate the introduction of a first generation, commercial mobile satellite system. This would be

achievable by the timely transition of high-risk critical technologies to industry. To ensure the economic viability of MSS, the research has as a general goal the development of technology which will enable low cost equipment for end users.

Throughout the program, JPL has tried to maintain a balance between general MSS studies and certain focused areas of technology development. These technology areas evolved out of the early system studies and are considered crucial to the eventual success of MSS. Thus, MSAT-X has proceeded with a nucleus around which the MSS concept could be developed and demonstrated. The core technology areas, all of which emphasize efficient utilization of scarce resources (power, frequency spectrum and orbital slots) are:

- o vehicle antennas,
- o near-toll-quality digital speech,
- o modem design,
- o networking and multiple access techniques, and
- o mobile satellite channel characterization and modeling.

MSAT-X is a multi-faceted program: this paper, and the other MSAT-X papers presented in this conference, are only capable of presenting the major findings. In an effort to make the material readily accessible, this paper concentrates on a baseline system concept which is firmly rooted in realized hardware. This requires certain system architecture assumptions, which are outlined in the body of the paper.

The paper will identify the MSS elements and propagation environment; elaborate on the critical technology areas; touch on testing and validation; and present MSS configurations based principally on the ground segment technology and system studies performed to date.

2. MSS ELEMENTS AND ENVIRONMENT

MSS is a satellite based communication network that provides voice and data communications to mobile users over a vast geographical area. The relay satellites in geosynchronous orbit permit an extremely large coverage area. The type of service provided is particularly suited to low density or rural areas and augments the terrestrial systems which are economical in localized areas. The services envisioned for MSS include two-way voice, two-way interactive data communication, and one-way data as in dispatch operations, position determination or data base query.

The MSS network concept is depicted in Fig. 1. The Network Management Center (NMC) oversees the operation of the network and performs vital functions such as answering requests for channel assignment, setting up call routes, billing, etc. The gateways are terminals that provide interfaces between the MSS and other networks such as the Public Switched Telephone Networks (PSTN). The base stations are not necessarily connected to other networks and are normally centers for dispatch operations.

The two other key elements in MSS are the mobile terminal (MT) and the satellite(s). The mobile operates in a hostile environment where multipath from terrain exists together with shadowing from trees or obstacles. The MT is located within the mobile vehicle and comprises the radio, antenna, and user interface. This equipment is constrained to be low-cost and small in size to ensure a wide customer base and

economic viability of the resulting MSS. The spacecraft, on the other hand, is limited by the feasible technology and evolves in steps or generations. As new technology becomes available, new spacecraft will be used to support the expected growth in MSS.

3. TECHNOLOGIES DEVELOPED UNDER MSAT-X

Although the choice of technologies to be developed under MSAT-X emphasized those that would be applicable to more than one MSS architecture, a broad MSS conceptual design had to be formulated to create a cohesive framework for the development. A system concept evolved out of JPL and NASA/contractor studies performed in the early eighties [Naderi 1982; TRW 1983; G.E. 1983]. A system based on FDMA combined with spacecraft that utilize multibeam technology to effect frequency reuse was adopted. Although architectures based on CDMA or TDMA cannot be dismissed without thorough analysis, they have drawbacks in the MSS environment which made them unattractive [Dessouky and Sue 88].

In conjunction with the FDMA architecture, studies have shown that a basic 5 kHz channel bandwidth is optimum for MSAT-X. This choice matched the selection of 4800 bps near-toll-quality vocoded voice, and represented the challenging goal of achieving a 1 bps/Hz modulation/coding throughput on the multipath channel with small inexpensive mobile terminals-- a heretofore unrealized feat.

The development effort in all areas (vehicle antennas, modulation/coding, speech compression and networking) is aimed at realizing working hardware/software that can be demonstrated reliably in the field. In parallel, better characterization of the propagation channel and its effects has been pursued. In what follows the salient achievements in the four technology areas and propagation modeling are highlighted.

Vehicle Antennas

Early in the MSAT-X program low gain antennas (LGA's) were investigated [Naderi, et al. 1984]. LGA's can provide up to 5 dBi in gain. An example is the crossed-drooping dipole antenna which provides 3.3 to 4.8 dBi for the desired elevation angles between 20 and 60°, with the minimum being at 20°. Preliminary tests have shown that a MT receiver (receiver noise figure = 0.86 dB) equipped with such an antenna would have a G/T of about -20 dB/K. The advantages of LGA's are their very low cost and simplicity. Their disadvantages are: 1) low gain, which creates a power burden on the satellite and may lead to the need for high risk spacecraft development; 2) susceptibility to multipath from near the horizon; and 3) because of their wide beams, the inability to support orbit reuse which will likely be needed to support the capacity of a mature MSS (see Section 5).

Motivated by the need to support orbit reuse and increase the vehicle antenna gain, medium gain antennas (MGA's) were developed. Three types of arrays were considered: mechanically steered tilted linear array, conformal electronically steered phased array, and planar mechanically steered array. Because of the low profile of these antennas and the presence of the conducting ground plane (car top), the most difficult challenge for these antennas is attaining the desired minimum gain at low elevation (i.e., at 20°).

A breadboard for the mechanically steered linear array with its pointing system was developed in-house at JPL. Two contractors, Teledyne Ryan Electronics (TRE) and Ball Aerospace, have developed and delivered breadboards of the phased arrays antennas. Photographs of the two phased arrays mounted on vehicles are shown in Fig. 2. The two contractors' antennas meet the very demanding MSS requirements with varying success. The important characteristics of the MGA breadboards are summarized in Table 1; as can be seen, the TRE phased array currently exhibits better RF and physical characteristics. Consequently, it is the likely candidate for further refinement. A major area requiring improvement is the insertion loss. Reducing the internal loss contributes to increasing the G/T (receiver gain to effective noise temperature) through both raising G and reducing T. One of the main thrusts for the continuing work in the phased array area will be achieving a higher G/T. Improvements in G/T of more than 1 dB can be expected. Finally, as a middle ground between the lower cost of the linear array and the conformity of the phased array, a planar mechanical array is presently being developed by TRE. Again, higher gain and G/T are design goals.

Modulation/Coding

The spectrally efficient schemes of MSK and GMSK were first investigated for MSAT-X and a practical DGMSK modem was implemented for 2400 bps [Davarian, et al. 85]. With the shift to 4800 bps speech compression, attention was redirected towards combined modulation/coding schemes that, in addition to enhanced spectral efficiency offer improved power performance on the fading channel. After consideration of a number of coding and detection schemes, including pilot-aided modulation techniques, research revealed that for the MSAT-X environment at L-band rate $2/3$ 16-state trellis-coded differentially-detected 8PSK (TCM/D8PSK) with 100% root raised-cosine pulse shaping yields the best performance [Simon and Divsalar 87, Rafferty and Divsalar 88]. Interleaving is essential on fading (bursty) channels when trellis encoding is used. Only limited interleaving is possible because of a 60 ms delay constraint imposed for voice. Simulation was used to establish that under such a constraint the best block interleaving is 128 symbols (8PSK) with 16 symbols in depth by 8 in span with a buffer size of 32.

Fig. 3 together with Table 2 give comparisons of TCM/D8PSK with other schemes considered. No timing jitter or ISI are considered in these results. Yet, tests of the TCM/D8PSK modem developed at JPL on the hardware fading channel simulator have exhibited less than 1 dB deviation from theory. This has been a positive result that has lent confidence in TCM/D8PSK.

Speech Coding

It was realized early in the MSAT-X program that speech quality acceptable to the public could not be achieved at 2400 bps. The goal then became the attainment of near-toll quality (telephone) at 4800 bps with an inexpensive, compact speech coder through outside contract development.

Two research and development contracts were awarded: one to the University of California at Santa Barbara (UCSB) and the other to Georgia Institute of Technology (GIT). Both contractors have now developed speech coders based on the classical Linear Predictive Coding

(LPC) model for human speech. Each contractor has derived a new class of algorithms for modeling the excitation sequence to be used in conjunction with the LPC. Other notable contributions in this area have been in the reduction of algorithm complexity and LPC parameter quantization. Realization of the delivered coders has been based on general purpose DSP chips. For example, both contractors' coders require a 4 Mips processor which could readily be transferred into a low cost, custom chip set. Both speech coders have achieved good speaker identification and naturalness, intelligibility is "fair" and algorithm refinements are still on-going.

Networking

The objective in the networking area has been to develop a protocol that meets the unique needs of the MSS environment. A novel demand-assigned time-multiplexed FDMA scheme was developed at JPL to integrate voice and data services [Li and Yan 84], namely, the Integrated Adaptive Mobile Access Protocol (I-AMAP). Over the years since 1984 the protocol has been undergoing continuous refinement. At present it uses slotted ALOHA for connection requests and includes the appropriate error control techniques, such as request packet replication, acknowledgments, etc. [Wang and Yan 87].

The original intention was to test the algorithm through an operational network. It was soon discovered that the software development would be very costly [Signatron 85]. The development work was therefore limited to a controlled laboratory environment. The packet format for both the network level and link level has been specified [Wang and Yan 87] and has shown robust performance in the simulated environment.

Recently, a free-access, tree-type protocol has been developed for the connection-request procedure. It promises a stable useful throughput at least 30% above slotted ALOHA. This algorithm will also be tested and validated on the network test-bed simulator at JPL.

Propagation

Research efforts here have focused on obtaining more accurate propagation models for the MSS environment. A wide range of experiments have been performed to obtain vital channel characteristics including signal attenuation statistics, fading rate, depth and duration statistics, doppler spread, tree attenuation, and scattering from road-side objects. Two critical results have emerged. The first is implicit in the curves shown in Fig. 4 [Vogel and Goldhirsh 87, Bostian 87]. It indicates that although multipath can be significant and result in as much as 8 dB attenuation, foliage shadowing is the dominant cause of degradation, with at least 8 dB more attenuation than multipath alone. The second result [Vogel and Hong 87] indicates that multipath effects restrict the usable bandwidth to a few tens of kHz (for specified acceptable amplitude variations over the channel bandwidth). The two results are significant: the first reaffirms the premise that MSS will be a line-of-sight (LOS) system for voice links, and the second supports the choice of FDMA as opposed to CDMA or TDMA.

The data obtained from the propagation experiments and analysis are being continually incorporated into software simulations and the hardware channel simulator developed at JPL.

4. TECHNOLOGY VALIDATION

A major objective of the MSAT-X project has been the field testing of all critical mobile satellite equipment developed within the program. A sequence of Pilot Field Experiments (PiFEx) was introduced as means to evaluate MSAT-X equipment on an incremental basis. The use of such a testing strategy has been necessary because a true MSS satellite will not be available before the early 1990's.

An essential component in system demonstration is the presence of a MT framework capable of integrating and supporting the different equipment developed. Consequently, a considerable effort at JPL went into developing a MT architecture, subsystem interface definitions, and supporting hardware.

The architecture of the MT is shown in Fig. 5 [Cheetham 87]. The architecture is modular to accommodate continued subsystem evolution, and is centered around the terminal processor. The terminal processor serves as the master controller of the terminal. It implements the networking protocol, supervises the operation of the subsystems and their interfaces, and is capable of taking real-time decisions to ensure the integrity of the link.

Another key subsystem in the MT is the RF transceiver. A breadboard transceiver has been developed at JPL to meet the unique MSAT-X requirements [Parkyn 88]. The transceiver is capable of receiving two channels (one for data and one for the pilot reference signal), which are settable within the desired L-band frequency range. It also tracks doppler shifts in the received pilot and provides the necessary control signals for the antenna pointing subsystem.

To support the performance of the PiFEx experiments, JPL also developed a mobile terminal laboratory housed in a Propagation Measurement Van (PMV) [Emerson 87]. Creation of the mobile laboratory involved integrating the test equipment with the mobile terminal and/or its subsystems, plus the development of a Data Acquisition System (DAS) with its elaborate software. The PMV has been used extensively in the field experiments and will continue to be invaluable to the validation of MSS technology.

The early PiFEx experiments that have been conducted have, for example, demonstrated the viability of the vehicle antennas and their ability to acquire and track the transmitted reference pilot while the vehicle is moving. Present plans call for PiFEx experiments that will test the end-to-end link and all subsystem technologies developed and as yet not validated in the field.

5. MSS CONFIGURATION

Multibeam frequency reuse technology provides a means to maximize spectrum utility and is expected to be employed by MSS. The extent of frequency reuse is related to the size of the spacecraft antenna. Because of market and economic considerations, extensive frequency reuse is not expected until later generations. The following is a brief description of a possible system design for a first and second generation MSS.

5.1 First-Generation Satellite

Using a commercial high-power communications satellite bus, the first-generation MSS design would call for two 14-ft. (4.2 m) L-band multibeam antennas, one for transmit and the other receive. Separate transmit and receive antennas alleviate the potential problem of passive intermodulation generation. Four beams will be needed to cover CONUS and some coastal areas (Fig. 6). For the backhaul link, a 0.4-m ku-band antenna will generate a single beam covering CONUS. The satellite would have G/T values of 9.2 and 4.0 dB/K for the L- and Ku-bands, respectively. It would also have a 5000-lb GTO mass and 3 kW of spacecraft power. The number of channels and number of users that this satellite can support (and consequently the required spectrum) depend on several factors, viz., channel duty cycle, traffic mix, and service quality. For a service quality with 2% blocking probability and 3.2 sec. message delay, an assumed user traffic requirement of 1 90-sec. voice call or 1 4096-bit data message per hour per user, and assuming 40% of the traffic is attributable to voice, the satellite would support 1900 channels. These channels would be partitioned, according to the I-AMAP protocol, into 204 voice channels, 260 channels, and 1465 reservation channels. (The seemingly large number of reservation channels could be reduced if a longer delay can be tolerated.) This partitioning results in a total of 89,000 users being accommodated by one satellite, corresponding to approximately 50 users per channel.

A limited frequency reuse (by a factor of 4/3) can be achieved by the 4-beam system by re-using the same frequency in the two outer beams. Coupled with the bandwidth-efficient modulation that enables the transmission of 4.8 kbps in a 5-kHz channel, the system can potentially achieve 1.28 bps/hertz efficiency. Fig. 6 shows the satellite footprint. Table 3 briefly summarizes the link design, which is based on existing MSAT-X technologies, viz., medium gain antenna with 9.9 dBi gain at 20° elevation, low-noise amplifier with 0.86 dB noise figure, and a low-loss (0.6 dB) diplexer with 90 dB isolation.

5.2 Second-Generation Satellite

By employing a larger antenna, a second-generation satellite would achieve more extensive frequency reuse and provide higher capacity. Studies have indicated the feasibility of employing a 15-m mesh deployable on a high-power commercial satellite bus (Figs. 7 and 8, [FACC 85; RCA 85]. A 15-m system has been designed for generic MSS applications [Sue 87]. Such a satellite would generate about 30 spotbeams (Fig. 9), reuse the available spectrum 4 times, and would have a potential spectral efficiency of 4.1 bps/hertz. The satellite would weigh about 6200 lb at GTO, have 3.7 kW of spacecraft power, support about 12,000 channels, and serve hundreds of thousands of users.

6. CONCLUSION

NASA's MSAT-X is a research and technology development program aimed at establishing a sound technical basis for the introduction of a U.S. mobile satellite system. The studies performed and the technology developed and tested to date clearly demonstrate the feasibility of such a system. Moreover, by maintaining a firm grasp on the overall system requirements and applications, it has been possible to cast the

subsystem elements in a first, and a future, generation MSS configuration with a high degree of confidence. The on-going field tests play an essential role in the incremental testing of system concepts and technology and their refinement. In the absence of a true MSS satellite, MSAT-X has strived, with a large measure of success, to establish meaningful alternatives to validate the system concepts and recommendations which have evolved out of the program.

Near term MSAT-X activities include the continued validation and evaluation of developed technology and system concepts and their transfer to industry. In addition, an experimental government agency network configuration is under consideration which would make use of channel capacity on a U.S. MSS.

The viability of a commercial MSS is dependent on many technical, economical, and social factors. NASA, through its various mobile satellite programs, continues to be a strong advocate for MSS and satellite communications in general.

REFERENCES

- C. Bostian, "Propagation Studies Related to LMSS," Proceedings of NAPEX XI (JPL Internal Document D-4647), Jet Propulsion Laboratory, Pasadena, California, August 31, 1987.
- C. Cheetham, "The Terminal Processor: The heart of the Mobile Terminal," MSAT-X Quarterly Report No. 12, October 1987.
- F. Davarian, et al., "DMSK: A Practical 2400-bps Receiver for the Mobile Satellite Service," Msat-X Report, JPL Publication 85-51, June 15, 1985.
- K. Dessouky and M. K. Sue, "MSAT-X: A Technical Introduction and Status Report," JPL Publication, to be published in Spring 1988.
- R. F. Emerson, "Pilot Field Experiments," Proceedings of NAPEX XI (JPL Internal Document D-4647), Jet Propulsion Laboratory, Pasadena, California, August 31, 1987.
- V. Li and T-Y. Yan, "An Integrated Voice and Data Multiple-Access Scheme for a Land-Mobile Satellite System," IEEE Proceedings, Vol. 72., No. 11, November 1984.
- F. Naderi, Editor, "Land Mobile Satellite Service (LMSS): A Conceptual System Design and Identification of the Critical Technologies," Part II, Technical Report, JPL Publication 82-19, Feb. 15, 1982.
- F. Naderi, et al., "NASA's Mobile Satellite Communications Program; Ground and Space Segment Technologies," Proc. 35th Annual International Astronautics Federation Congress, Lausanne, Switzerland, October 1984.
- J. Parkyn, "L-Band Receiver for MSAT-X," MSAT-X Quarterly No. 13, (Special Issue on PiFEX Tower-1 Experiments), January 1988.
- M. K. Simon and D. Divsalar, "The Performance of Trellis Coded Multilevel DPSK on a Fading Mobile Satellite Channel," JPL Publication 87-8, June 1, 1987.
- W. Rafferty and D. Divsalar, "Modulation and Coding with Doppler Estimation for Land Mobile Satellite Channels," To be presented at IEEE International Conference on Communications, June 1988.
- M. K. Sue, "A High-Capacity Aeronautical Mobile Satellite System," Proceedings of the 37th IEEE Vehicular Technology Conference, June 1987.

- W. Vogel and J. Goldhirsh, "Multipath Measurements at L-Band and UHF in Mountainous Terrain for Land-Mobile Satellite System," Proceedings of NAPEX XI (JPL Internal Document D-4647), Jet Propulsion Laboratory, Pasadena, California, August 31, 1987.
- W. Vogel and U. S. Hong, "Measurement and Modeling of Land Mobile Satellite Propagation at UHF and L-band," Proceedings of NAPEX XI (JPL Internal Document D-4647), Jet Propulsion Laboratory, Pasadena, California, August 31, 1987.
- C. Wang and T-Y. Yan, "A Simulator for the MSAT-X Request Channel," JPL MSAT-X Quarterly, No. 12, October 1987.
- C. C. Wang and T-Y. Yan, "Performance Analysis of An Optimal File Transfer Protocol for Integrated Mobile Satellite Services," Globcom, Nov. 1987, Tokyo, Japan.
- FACC, 1985. "Spacecraft Configuration Study for the Second Generation Mobile Satellite System," Final Report Prepared By Ford Aerospace and Communications Corporation Under Contract to JPL, January 1985.
- GE, 1983. "Mobile Radio Alternative Systems Study- Vol. 3: Satellite/Terrestrial (Hybrid) Systems Concepts," GE Technical Report, Prepared for NASA Lewis Research Center, June 1983.
- RCA, 1985. "Spacecraft (Mobile Satellite) Configuration Design Study," Final Report Prepared By RCA Astro Electronics Under Contract to JPL, June 1985.
- Signatron, 1985. "MSAT-X Networking System Study Final Report- Vol. 1: A Feasibility Assessment of I-AMAP," JPL Publication 9950-1198, 8 June 1985.
- TRW, 1983. "Mobile Communications Satellite Systems," Vol. 2, TRW Tech. Report, Prepared for NASA Lewis Research Center, April 11 1983.

Table 1. Salient Characteristics of Medium Gain Antenna Breadboards
 *: Averaging gains over 8 azimuth beam positions.
 #: Height of mechanical linear array to be reduced to 4.5"

	JPL Mech. Tilted Linear Array	TRE Phased Array	Ball Aerospace Phased Array
	-----	-----	-----
Average* Recv. Gain (1545 MHz) dBi			
20° elev.	10.0	9.9	8.2
40° elev.	11.5	11.3	11.6
60° elev.	10.0	12.8	11.5
Av.* Transmit Gain (1660 MHz) dBi			
20° elev.	10.0	7.8	8.1
40° elev.	12.0	10.1	11.4
60° elev.	10.0	12.2	12.4
Av.* Recv. Sys. G/T at 20° (Rcvr NF=.86) dB/k	-15.2	-15.4	-16.7
Acquisition Time sec.	15	< 10	< 10
Track. Interf. to data			
AM dB (p-p)	negligible	1.5	1.5
PM deg (p-p max)	negligible	15	37
Size (ht. " x diam.)	9.0# x 20.0	0.7 x 20.7	1.3 x 24.0
Est. Manfctng. Cost	\$600	\$1848	\$1610

Table 2. Comparison of the performances of TCM/D8PSK, DQPSK and DGMSK under typical MSS link conditions. (No ISI or timing jitter.)

	EB/NO (@ 1E-3) (K=10; 40 Hz doppler spread)	Relative BW (main lobe, also 99.9% BW)
DQPSK	12.2	1
DGMSK BT=.5	13	1.6
TCM/D8PSK (R=2/3; 16-state 128 8PSK Symbol Interleaving)	9.5	1

Table 3. Link Budget for First-Generation MSS (Assuming TCM/D8PSK at 1E-3 BER)

	FORWARD LINK		RETURN LINK	
	GRND-SAT	SAT-USER	USER-SAT	SAT-GRND
XTMR POWER, WATTS	1.0	0.8	1.6	0.1
ANTENNA GAIN, DBI	49.6	33.7	7.8	31.2
EIRP, DBW	47.6	31.1	8.5	19.7
PATH LOSS, DB	-206.9	-188.3	-188.9	-205.8
RECEIVE G/T, DB/K	4.0	-15.4	9.2	21.0
RECEIVE C/No, DB/HZ	66.3	51.9	53.2	56.7
OVERALL C/No, DB/HZ	--	51.1	--	51.1
REQUIRED C/No, DB/HZ	--	47.8	--	47.8
REQUIRED EB/No, DB	--	11.0	--	11.0
MARGIN, DB	--	3.3	--	3.3

ORIGINAL PAGE IS
OF POOR QUALITY

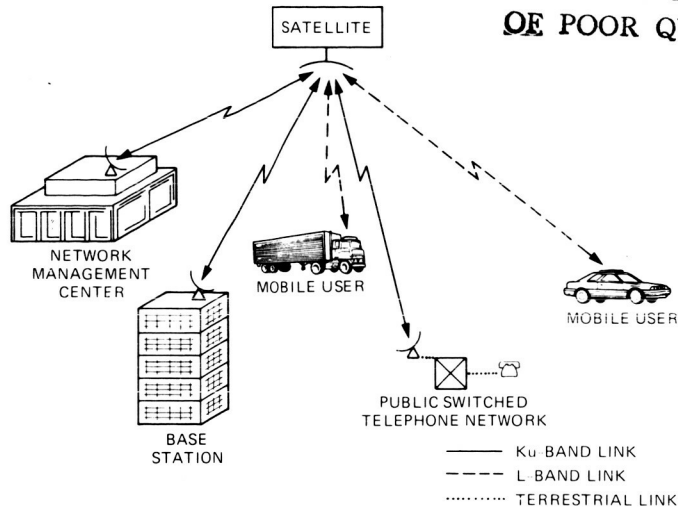

Fig. 1. Mobile Satellite Network Concept



BALL DESIGN



TELEDYNE DESIGN

Fig. 2. MSAT-X Phased Array Antennas Mounted on Vehicles

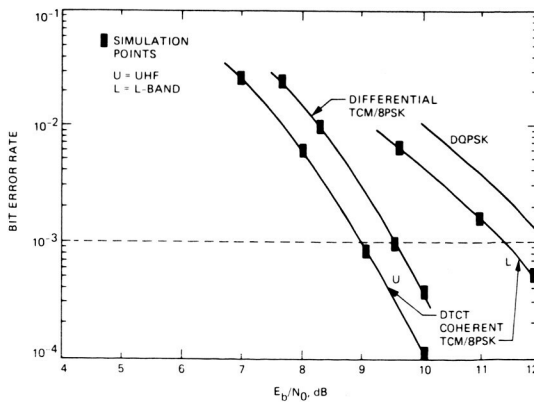

Fig. 3. Comparison of TCM/D8PSK With Coherent TCM/8PSK (Using DTCT With Noisy Pilot) and DQPSK at UHF and L-Band

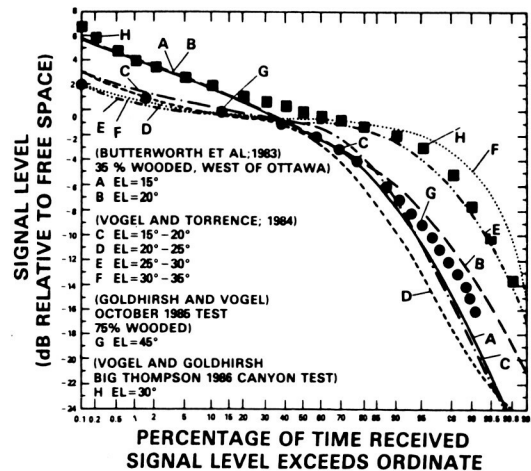

Fig. 4. Cumulative Signal Level Distribution for Various Geographical Locations and Elevation Angles. (See [Bostian, 87] for References Cited.)

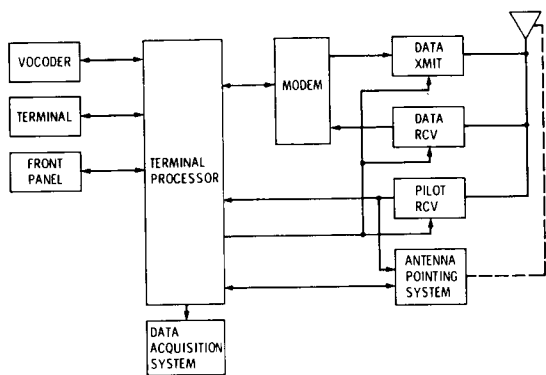

Fig. 5. Mobile Terminal Block Diagram

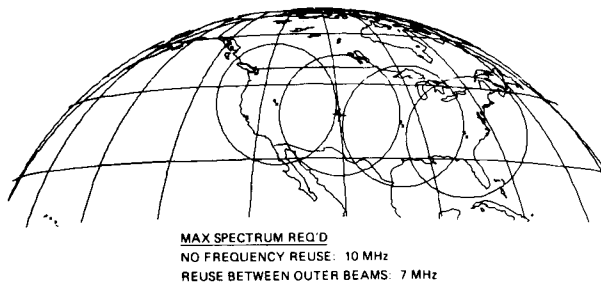

Fig. 6. A First Generation Satellite Beam Layout (Courtesy of Dr. Vahraz Jamnejad)

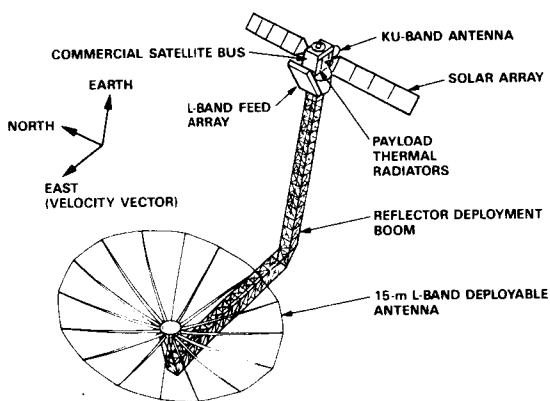

Fig. 7. On-Orbit Spacecraft Configuration (Second Generation) (FACC Design)

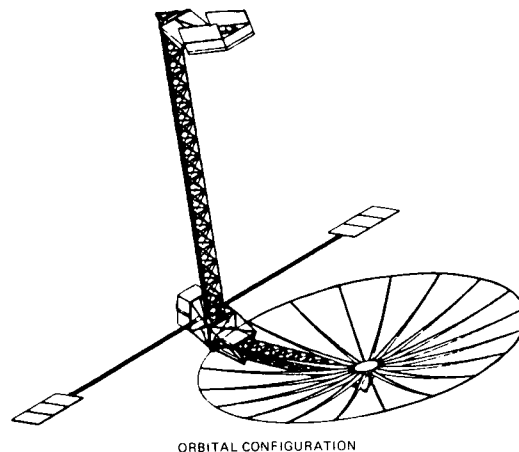

Fig. 8. On-Orbit Spacecraft Configuration (Second Generation) (RCA Astro-Electronics Design)

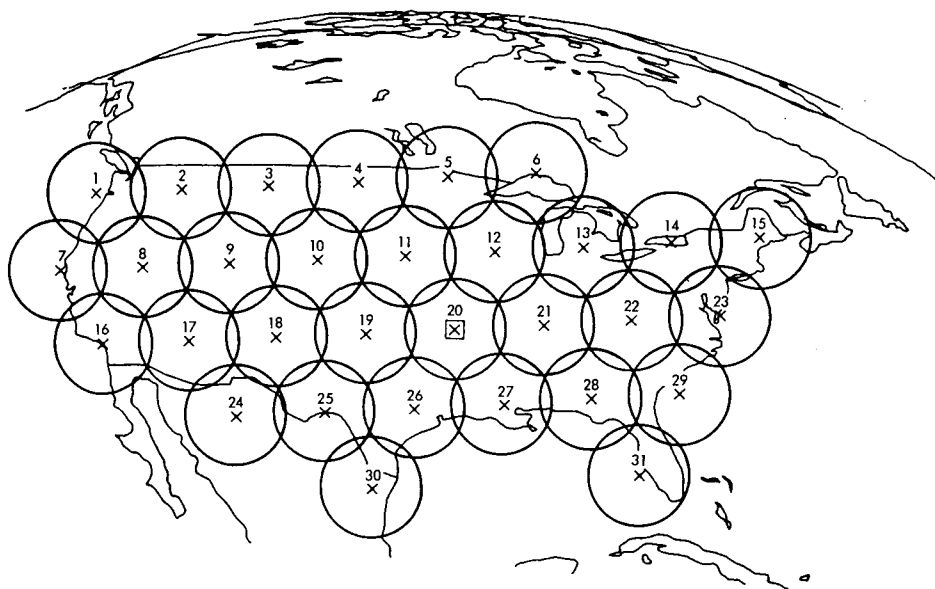

Fig. 9. A Second Generation Satellite Beam Layout