

N88 - 25708

THE JPL MSAT MOBILE LABORATORY AND THE PILOT FIELD EXPERIMENTS

JEFF B. BERNER, Mobile Satellite Program, Jet Propulsion Laboratory, California Institute of Technology, United States; RICHARD F. EMERSON, System Subtask Manager, Mobile Satellite Program, Jet Propulsion Laboratory, California Institute of Technology, United States.

CALIFORNIA INSTITUTE OF TECHNOLOGY  
JET PROPULSION LABORATORY  
4800 Oak Grove Drive 161-228  
Pasadena, California 91109  
United States

ABSTRACT

JPL has developed a Mobile Laboratory/Propagation Measurement Van (PMV) to support the field experiments of the Mobile Satellite Experiment (MSAT-X) Project. This van was specially designed to provide flexibility, self-sufficiency, and data acquisition to allow for both the measurement of equipment performance and the measurement of the mobile environment. This paper will describe the design philosophy and implementation of the PMV. It will then discuss the special aspects of the PMV that are unique to Pilot Field Experiments (PiFEx). And finally, it will provide an overall description of the three experiments in which the PMV has been used.

INTRODUCTION

The Mobile Laboratory/Propagation Measurement Van (PMV) was developed to support field experiments for the Mobile Satellite Experiment (MSAT-X) Project. Since these experiments involve both a measurement of the environment and a measurement of the performance of equipment specifically designed for MSAT-X, special emphasis was placed upon flexibility, self-sufficiency and data acquisition. Following a brief description of the PMV, these three aspects will be addressed in more detail. In addition a brief description of the PiFEx tests that have been conducted will be given. Finally, future plans will be outlined.

PROPAGATION MEASUREMENT VAN

The PMV is composed of two elements-- the vehicle, itself, and the support trailer (Figure 1). These elements combine to provide the following functions: Power; Storage; Transportation; Equipment Mounting; Environmental Control; Support Test Equipment; Signal and Power Distribution; and Position Location, Speed and Time.

The vehicle portion of the PMV is a minimally modified "stretch" 1-ton Ford van with a payload capacity of 4200 pounds. The cargo volume of 300 cubic feet is sufficient for two pairs of 4 foot equipment racks. There is enough room between the racks for two people to work comfortably; unfortunately there is not enough room for two seats.

Two aspects of the van's environment are subjected to some control: temperature and shock and vibration. Heat exchangers for the standard truck air conditioner compressor are provided in the cab area and in the payload area. The capacity of the compressor is approximately 2.5 tons, which has proved sufficient even on days with above 90° F ambient temperatures. Air circulation is provided by 48 sixty CFM fans mounted in the equipment racks and heating is supplied by the standard truck heater. Shock and vibration are controlled to some degree by mounting the equipment in heavy racks which are, themselves, shock mounted to the van (Figure 2).

Laboratory instruments were included for the measurement of frequency, time interval, power, voltage, current, spectra and waveform. In addition, the van's position is measured by LORAN C, speed is determined by an interface to the van's transmission, and time is supplied by a WWV receiver. Signal and power distribution is through cable raceways built into the side of the van. This approach enhances the flexibility of the van without compromising safety.

The support trailer provides storage of spares, tools, and the equipment for the fixed station and transponder. It also provides mounting for the motor generator which supplies the 110 volt A/C. The capacity of the generator is 6500 W.

#### Design for Flexibility

The use of standard RETMA racks with slides allows for the flexible placement of the equipment within the van. Eleven spare RF cables and two spare cable raceways were included to allow a modest amount of expansion. Nearly 100% excess A/C power capacity was provided by the use of a 6.5 kW generator. (Future experiments are expected to use a significant portion of this capacity.)

#### Design for Self-Sufficiency

Spares were provided for all special equipment (MSAT-X) to the board level and, where appropriate, to the component level. Test equipment, tools, jigs and fixtures needed for repair and calibration with a wide selection of test cables and adapters were included. Emergency equipment including tire chains, trouble lamp, and battery charger were provided.

#### Data Acquisition

Data acquisition was provided for in three areas: Digital, analog, and visual.

Digital Data Acquisition is accomplished by an augmented industrialized IBM PC/AT (Figure 3). Four channels of simultaneous-sample-and-hold A to D converters were installed to collect the inphase and quadrature outputs of the two receivers-- MSAT-X and Reference. Further, eight channels of multiplexed A to D converters were provided to capture assorted slower data. Digital signals were captured with a 96 channel digital I/O card. The digital signals come from several of the units such as the antenna controller, transceiver, speedometer and, in the future, the terminal processor. RS-232C and IEEE 488 interfaces are also provided to interface with the LORAN C Receiver and laboratory instruments. The data are stored on a dual drive 20 MByte Bernoulli box; a removable cartridge disk. Data Acquisition software provides continuous sampling and recording of data with a modest amount of data displayed in real time. Calibration and verification software can be run in non-real time to validate the data acquisition process.

Analog recording was accomplished by using a 7 channel FM-FM data recorder capable of 10 kHz bandwidth. One of the channels is used for calibration and compensation which improves the fidelity of the recording.

Visual data was captured both on video tape and 35mm still camera.

## EXPERIMENTS

The PMV has been thus far used on three major experiments: Tower-1 (T-1), Satellite-1a (S-1a), and Tower-2 (T-2). A brief description of each follows.

### Tower-1

The Tower-1 experiments were conducted in Erie CO at the NOAA Wave Propagation Laboratory (WPL) Facility (Figure 4). This facility has a 1000 foot tower capable of supporting several hundred pounds of equipment at any height from ground level to 1000 feet. A translator and omni antenna were mounted on the tower carriage to simulate the spacecraft. These were illuminated from a fixed station housed in one of the WPL shelters. The van with test equipment, units under test, and data acquisition equipment was placed around the base of the tower so that the tracking antenna was illuminated at various angles from 15 to 60 degrees. Antenna pattern, antenna acquisition and modem performance tests were performed with the van stationary. In addition to verifying the system operation (fixed site, translator and mobile site equipments), the information gathered during these tests provides a basis for the comparison of results during the mobile tests and data to assist in subsystem optimization.

Antenna tracking and modem performance tests were also conducted with the van in motion. Several tests were conducted along the north-south road to the east of the tower. This path provided the greatest elevation angle of all those available at the site.

To conduct the mobile antenna tracking tests, the signal level was set and the antenna was acquired with the van stationary at one of the corners. Data acquisition was started and the van accelerated to 30 MPH. The 30 MPH speed was maintained for the 1 mile path to the other corner where the van was turned and driven back. A complete 2.5 minute data block was captured in this way. (For T-1, the DAS only had the capability to record data in 2.5 minute increments.) Tests were made at signal levels which represent the minimum, maximum and nominal values for the expected system.

A similar procedure was followed for the modem tests with the parameter being the signal-to-noise ratio of the modulated signal. The data were recorded on the analog tape recorder. The duration of the test was determined by the recording time per tape cartridge, about 6 minutes.

### Satellite-1a

The S-1a experiments were conducted in Santa Barbara, CA, using the INMARSAT MARISAT satellite. This satellite provided an unmodulated L-band carrier from a beacon transmitter which the JPL developed mechanical antenna could track. Both the elevation angle and the received signal strength were well below the MSAT equipment's design values, but the experiment was still a success. Only the ability to track a satellite was tested in this experiment; no modem test could be done. The experiment consisted of acquiring the beacon while the PMV was mobile and tracking the satellite while driving over roads that provided a variety of conditions. For this experiment, the DAS was able to take data continuously, instead of in 2.5 minute slices. Over 500 MBytes of data were collected.

### Tower-2

The T-2 experiments were again conducted in Erie, CO at the WPL Facility. This time, the main emphasis was to test the Teledyne-Ryan Electronics phased array antenna. The same set of tests conducted at T-1 (except for the modem tests) was accomplished with the phased array. For continuity, the mechanical antenna was also tested again at this time.

This experiment demonstrated the flexibility of the PMV. The PMV had to accommodate the pointing and control electronics for two different antennas, while allowing for the ability to switch from one antenna to the other with minimal effort and time. Also, a new addition to the DAS allowed the operators to observe assorted pointing information in real time. Previously, this data could only be observed after the test.

### CONCLUSIONS

The complement of equipment was found to be appropriate for the experiments conducted during the three experiments. This will be reviewed prior to each subsequent experiment to assure success in the field. The data acquisition system was placed in the racks assuming

two people would be required to conduct the experiments. The experience has shown that the experiments can be conducted with only one operator. Therefore, the DAS should be moved to provide easier access.

Approximately 750 MBytes of digital data, 280 minutes of analog data, and several hours of video tape have been collected during the three experiments. Preliminary analysis of the antenna data has led to improvements in the design of the mechanical antenna and the modem data has been used in the development of the final version of the modem. The data collected from S-1a is being used by the MSAT system team to determine fade rates and fade durations that may be encountered. Due to the sheer mass of data that exists, complete evaluation of the data will not be completed for some time.

#### FUTURE PLANS

These tests were the first of several field tests to be done with the PMV and MSAT-X equipment. Tower-3 tests are planned for Summer of 1988 and will be used to conduct the first field end-to-end test of the MSAT system. Real-time modem tests will be conducted and initial verification of the Network ARQ protocol will be done.

Later this summer, the PMV will conduct the second satellite test (S-1b). This will take place in Hawaii, again using an INMARSAT satellite. Both of the antennae that have previously been tested and the second phased array antenna (Ball Aerospace) will be used in the experiment. Hawaii was selected because it will provide an elevation angle of 50° to the satellite. While the configuration only supports one way operation, this is adequate to continue performance measurements of the antennae and to conduct realistic propagation experiments with the L-Band satellite to mobile ground link.

#### ACKNOWLEDGMENTS

We appreciate the fine support that the staff at WPL provided, particularly the help of John Gaynor, Dave Gregg and Norbert (Ski) Szczepczynski. We also appreciate the PMV design assistance given by Dr. W. Vogel of the University of Texas. His experience with a similar vehicle so freely shared helped us avoid many a pitfall. Finally, a special word of appreciation for the dedication of the JPL MSAT-X team who accompanied us to the field: Walt Mushagian, Norman Lay, William Rafferty, Jim Parkyn and Vahraz Jamnejad.

ORIGINAL PAGE IS  
OF POOR QUALITY

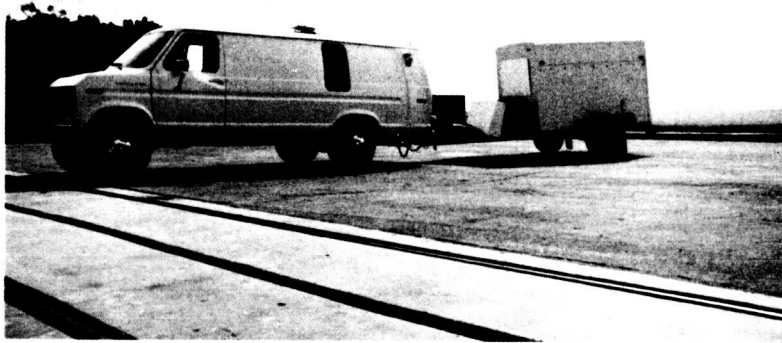

Figure 1: The Van and Trailer

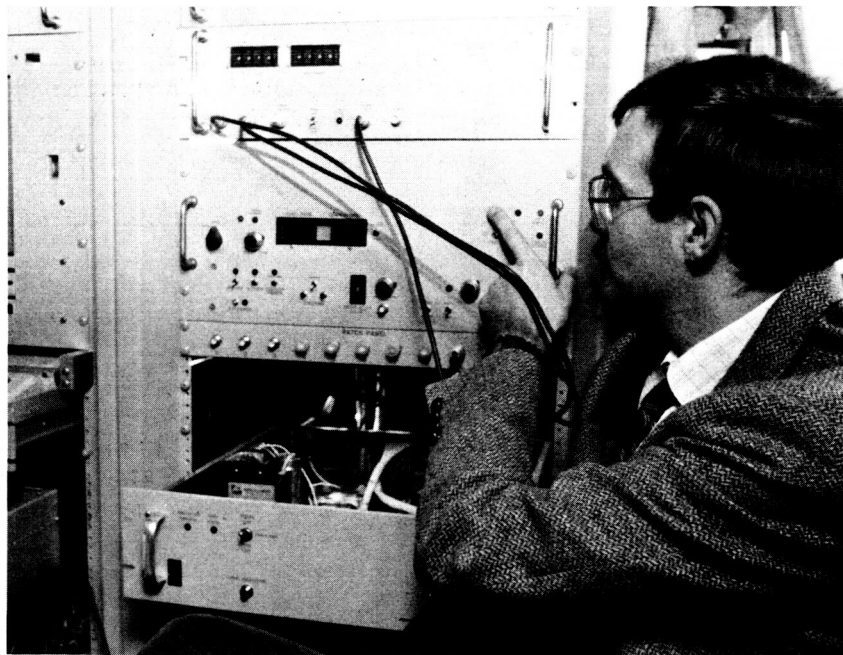

Figure 2: The Interior of the Van

ORIGINAL PAGE IS  
OF POOR QUALITY

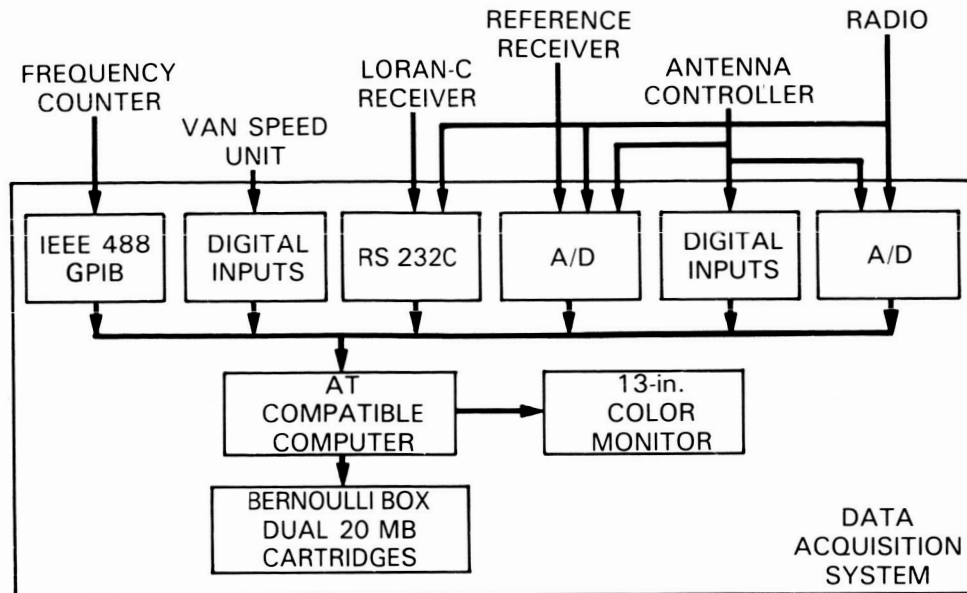

Figure 3: DAS Block Diagram

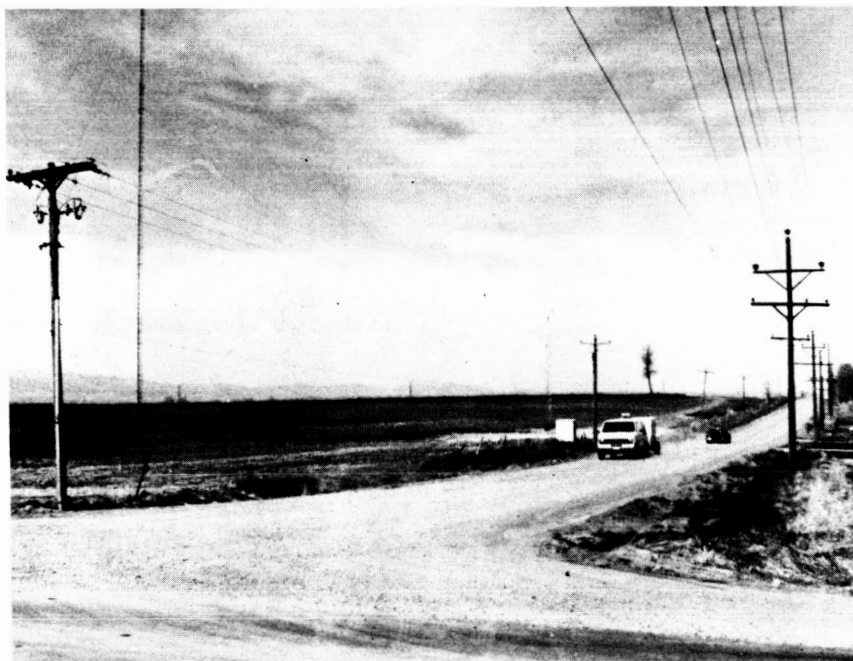

Figure 4: Tower and Van in Erie