

AMES

NASA Technical Memorandum 88233

111 54
157146

Space Station Proximity Operations Windows: Human Factors Design Guidelines

Richard F. Haines

MARCH 1987



NASA Technical Memorandum 88233

Space Station Proximity Operations Windows: Human Factors Design Guidelines

Richard F. Haines

Ames Research Center

Moffett Field, California



National Aeronautics
and Space Administration

Scientific and Technical
Information Branch

1987

TABLE OF CONTENTS

Page

1. INTRODUCTION	1
1.1 Window Design Assumptions	2
1.2 Window Design Philosophy	3
1.3 Proximity Operations Station	3
2. SOLAR RADIATION, AMBIENT GEOMETRY, AND CYCLIC TIMING	7
2.1 Basic Characteristics	7
2.2 Temporal Characteristics	10
2.3 Earthlight and Moonlight	13
3. ARTIFICIAL ILLUMINATION GEOMETRY	15
3.1 Space Station Light Sources	15
3.2 Shuttle (or "Active" Moving Target) Light Sources	16
4. HUMAN OBSERVER TASKS AND RELATED WINDOW DESIGN REQUIREMENTS	16
4.1 Selected "Return/PROX-OPS" Maneuver Requirements	17
4.2 Special "Deployment/Separation" Maneuver Requirements	25
4.3 Space Station Construction Activities	26
4.4 Human Factors Design Tradeoff Parameters	26
4.5 Distribution of Various Sensitivities in the Visual Field	39
4.6 Number of Viewers per Window	41
4.7 Number of Windows and Location Relative to Viewers	43
4.8 PROX-OPS Station Controls and Displays Relative to the Windows	44
5. WINDOW OPTICAL REQUIREMENTS	45
5.1 Transmissivity	46
5.2 LOS Deviation (Prism Effect) and Light Scatter	50
5.3 LOS Displacement	52
5.4 Magnification/Minification of Image	54
5.5 Astigmatism	55
5.6 Surface Reflections and Haze	55
5.7 Sunshades	56
6. WINDOW MAINTENANCE AND PROTECTION	57
6.1 Types of Degradation/Damage	58
6.2 Candidate Methods of Maintenance	67
6.3 Candidate Methods of Protection On-Orbit	69
6.4 Crew Safety Threats Related to PROX-OPS Windows	69
7. CONCLUDING COMMENTS	70
APPENDIX: WINDOWS USED IN PREVIOUS SPACE VEHICLES	71
REFERENCES	95
INDEX	102

1. INTRODUCTION

Personnel of the Aerospace Human Factors Research Division, NASA Ames Research Center, have been tasked, by an Intercenter Agreement, to provide support to the Lyndon B. Johnson Space Center, Houston, in the area of general habitat design (among others). "Human behavior and performance guidelines for 1) architectural decisions associated with crew needs for volume, privacy, observation windows, color..." will be addressed. Highest priority will be given to research directed toward addressing Space Station initial operating concept design issues. The present report presents human factors design guidelines and other background information related to Space Station windows. Of central importance are those windows to be part of the Proximity Operations (PROX-OPS) areas which will be used to (visually) monitor "return, rendezvous, berthing" and "deployment, separation, departure" operations.

Several reports have provided overall design guidance for this report. They include NASA TM-86652 (1984) and NASA TM-87493 (1984). General guidelines were also obtained from the Department of Transportation (1972) and the Society of Automotive Engineers (1978).

Specific design guidelines embedded within surrounding explanatory text are

placed within a box to help make them easier to find (example)
--

It was felt that the rationale for the guidelines was as important as the guidelines themselves, particularly in those instances in which tradeoffs need to be made.

There has been relatively little written on the important subject of spacecraft windows. Many of the references cited have to do with optical properties of glass, micrometeorite pitting in space, and related structural engineering characteristics of specific spacecraft window installations. This report assumes that windows will be required on the Space Station to support a wide variety of manned operations as well as to contribute to the overall habitability of its interior. As stated in NASA TM-87493 (1984, p. 3), "One of the principal advantages of this configuration is the good viewing afforded to all payloads, both externally mounted and internally mounted." Such viewing will require properly designed windows; such windows are the subject of this report.

Several subjects are not discussed here because they have already been considered elsewhere or they do not have a direct or indirect impact on human operations on board the Space Station. For example, if it can be shown that the observer's line of sight through a window is operationally influenced by the choice of glass pane thickness, type of edge mounting, type of glass, pressure or temperature differential, or other physical factors, then such factors need to be considered here. Also, it was decided to concentrate on the general design features of spacecraft windows here since the exact module configuration for Space Station has not been determined.

Not included here are such topics as

- Dielectric properties of glass windows
- Thermal radiation properties (e.g., absorptivity-to-emissivity ratio)
- Strength-to-weight ratio of glass
- Optical aids for external viewing (periscope, closed-circuit TV)
- Head-up display technology or symbology
- Justifications for using windows versus closed-circuit TV

Use of windows as detectors of micrometeorite impact events or solar flare iron nuclei etching
(e.g., Shirk and Price, 1974)

Space telescope optics (design, construction, cleaning, etc.)

Unmanned spacecraft components except where optical windows possess wavelengths in the
visible spectrum and the reference has some direct relevance to human performance

Allowable leak-rate between panes

The author wishes to thank the following people for their support in the preparation of this report. Marc Cohen and Maria Junge of Ames Research Center made useful suggestions as did Michael Donahoo and Clay Anderson of the Johnson Space Center, Houston, and Stephen Hall of the Marshall Space Flight Center, Huntsville. Valuable information on the Soviet Salyut vehicle was provided by B. J. Bluth under grant support from NASA Headquarters, by Frank Winter and Cathleen S. Lewis of the National Air and Space Museum, and by Craig Covault of *Aviation Week and Space Technology*. The assistance of Sam Ximemes of the Environmental Center, Houston, and William Rosenfield of the Space Transportation and Systems Group, Rockwell International, is also gratefully acknowledged. Portions of the computer programs and calculations for window field of view figures were done by Wade Schauer, University of the Pacific.

1.1 Window Design Assumptions

Several assumptions have been made for this report which take into account other requirements and assumptions (Donahoo and Anderson, 1985).

- A. For the majority of PROX-OPS out-the-window activities there will be only one viewer per window. However, since the NASA RFP "Reference Configuration" for Space Station specifies viewing by two people per window, this requirement must be taken into account.
- B. A maximum window dimension of 20 in. (50 cm) will be allowed. The NASA RFP calls for two windows of 20 in. maximum dimension; however, it is reasonable to assume that 20- by 30-in. (50- by 75-cm) rectangular windows will be permitted from a structural standpoint.
- C. There will be no particular constraint on the shape of each glass pane as long as that shape can be justified from a human factors point of view.
- D. For most viewing activities through the PROX-OPS windows not having a superimposed head-up display (HUD) virtual-imaging system, a specific design eye point (DEP) will not necessarily be needed.
- E. For those windows which possess a HUD imaging system to be used for final approach/berthing (e.g. within the last 325 ft (100 m), a clearly defined DEP will be needed. Rather, a design eye volume (DEV) of 1.5 ft³ (0.4 m³) shall be provided for simultaneous viewing out of two adjacent windows.
- F. All lighting conditions (external and internal) are assumed to be adequate to support all necessary visual judgments (e.g., range, range-rate, size expansion, textural cue change, translational motion through PROX-OPS windows.
- G. Proximity operations will be initiated within approximately 1100 yd (1 km) from the window, with the payload located "...within direct visual contact within a range of 200 feet." (Oberg, 1982, p. 2-1)

- H. Proximity operations will be conducted (primarily) along a +V vector in order to keep the Sun at the viewer's back on board the Space Station.
- I. Closed-loop (manual control) as well as open-loop (monitoring) of orbital maneuvering vehicle (OMV) systems must be accommodated by the PROX-OPS windows.

1.2 Window Design Philosophy

The overall design philosophy for the PROX-OPS windows on Space Station include the following elements: (1) All windows will provide maximum horizontal and vertical field of view (FOV) from all likely body orientations to help all viewers achieve a high degree of situational awareness. A DEV will be designed for rather than a DEP. (2) Means shall be provided within the viewer's FOV to provide all necessary spatial orientation information for PROX-OPS conducted through the windows. (3) All windows will be triple-pane, tempered, flat glass. The cavity between the two inner panes will be evacuated and back-filled to an appropriate pressure (e.g., 7 psia) with a dry, inert gas. An outer pane is for micrometeoroid and radiation protection. The innermost pane is subjected to cabin pressure loading. The space between the two outermost windows will be vented to space. (4) Window mounting design will preclude installation stresses which would restrict the loading on the glass to the pressure differential between the space environment and the interior of the station. (5) The window frame thickness will be as small as possible to permit as narrow an occlusion to vision as possible from the DEP for that window. (6) All windows will provide neutral spectral transmission, i.e., no transmission changes at a particular wavelength which would alter the perceived hue (color) of a target viewed through the windows at any angle of view. (7) Any optical or radiation coating applied will not significantly degrade the structural integrity (strength, etc.) of the windows. (8) The window layout configuration (number of panes, shape, spacing, etc.) will be fully integrated into the structural design of the end cap.

The remainder of this report presents human factors-related information which concerns the above and other elements of PROX-OPS windows.

1.3 Proximity Operations Station

Oberg (1982, p. 2-1) defines PROX-OPS for Shuttle as the operation of one orbiting spacecraft in the vicinity of another. He goes on to say, "In more practical terms, it can be defined as a mission phase during which various dynamic trajectory management tasks are conducted by one of two coordinating satellites while in the near vicinity of the other. More specifically, the relative position and rates are sufficiently stabilized and small (usually <0.5 NM & 1 FPS) so as to preclude the requirement for rendezvous (with all attendant navigation, targeting and maneuver execution) in order to restore proximity." According to this definition, the PROX-OPS station on Space Station is that area from which proximity operations are carried out. Donahoo and Anderson (1985, p. 2-1) add, with specific reference to Space Station, that "As with PROX-OPS for the Space Transportation System (STS), the major objectives are to initiate a successful separation or return while at the same time avoiding recontact and excessive plume disturbances while minimizing vehicle performance costs and impact." The various human factors implications of these requirements are many and complex. Design of the window array for such varied operations must take into account what we have already learned in prior manned missions as well as what is known about the capabilities and limitations of the human visual system.

Figure 1 presents NASA's early concept for Space Station from NASA TM-87493 (1984, p. 15); only the five basic modules are shown for purposes of simplicity.

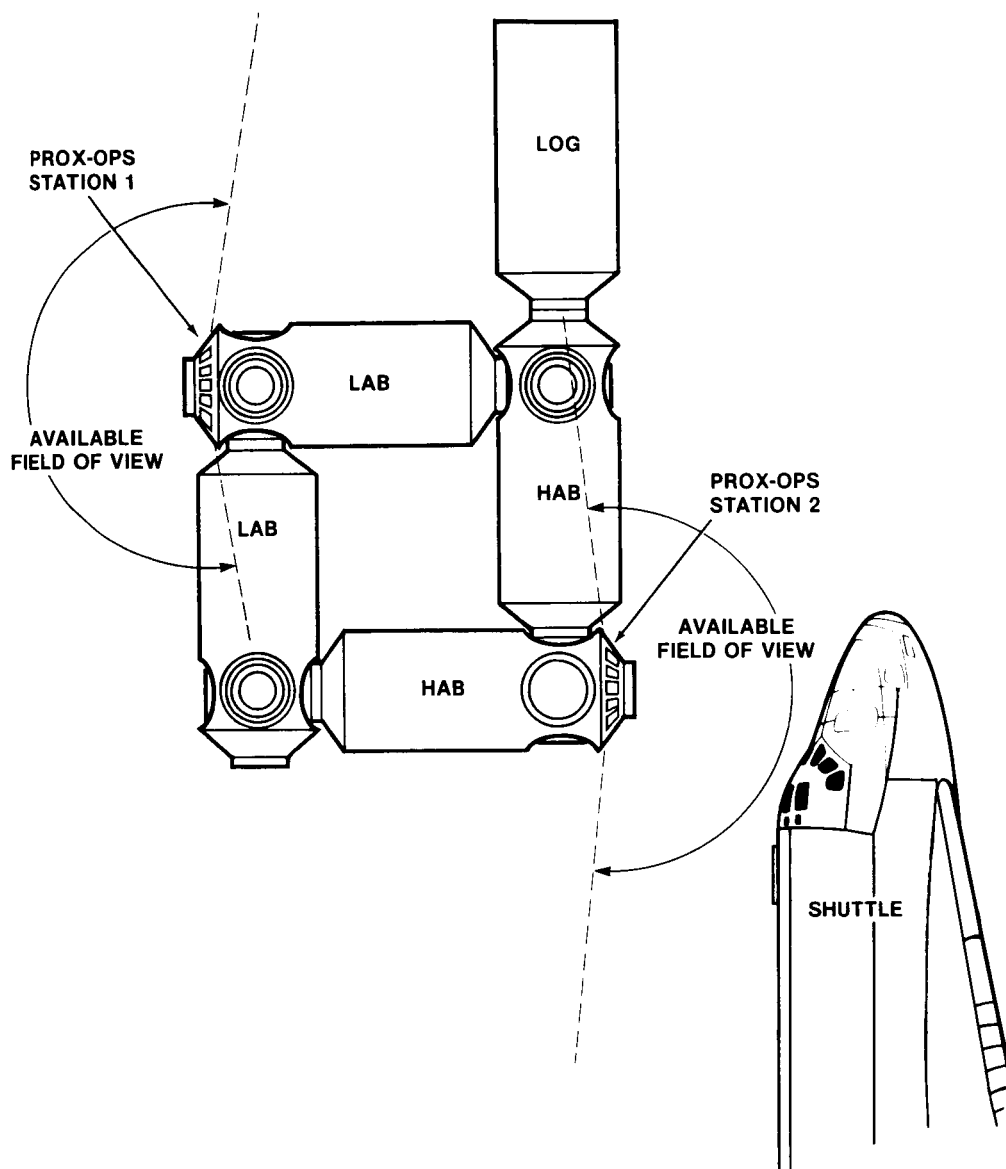

Figure 1.— Initial NASA reference module configuration.

Considering this module configuration, at least two separate PROX-OPS stations are assumed to adequately support the following Shuttle operations:

1. Approach
2. Berthing
3. Cargo transfer (to and from)
4. Deployment
5. Departure out to the vehicle's intermediate or final parking orbit

In addition, these PROX-OPS windows must support

1. Monitoring/controlling free-flyer maneuvers (within the available FOV and out to a range of about 2000 ft (610 m))

2. Monitoring manned maneuvering units (MMU)
3. Visual safety inspections of selected Space Station structure
4. Other visual judgments related to construction activity and conduct of scientific and industrial experiments
5. Habitability-related needs of the crew

It is necessary to introduce the subject of Space Station module end-cap candidate geometry as it influences the overall location, number, and shape of the individual windows. Several different structural configurations have already been suggested, as shown in figure 2. In each configuration are two subcategories related to where the docking port is located, viz., *centered* on the longitudinal axis of the module or *offset*.

One of the important human factors design criteria related to end-cap geometry and window dimensions is that of maximizing the external FOV from given head positions. Underlying this criterion is the concept of designing to maintain "situational awareness," which is the first design guideline to be presented.

It is important for the viewer(s) to have and maintain visual contact with as much spatial, temporal, and luminous information as possible from given head positions.

This topic is discussed in greater detail in section 4.6.

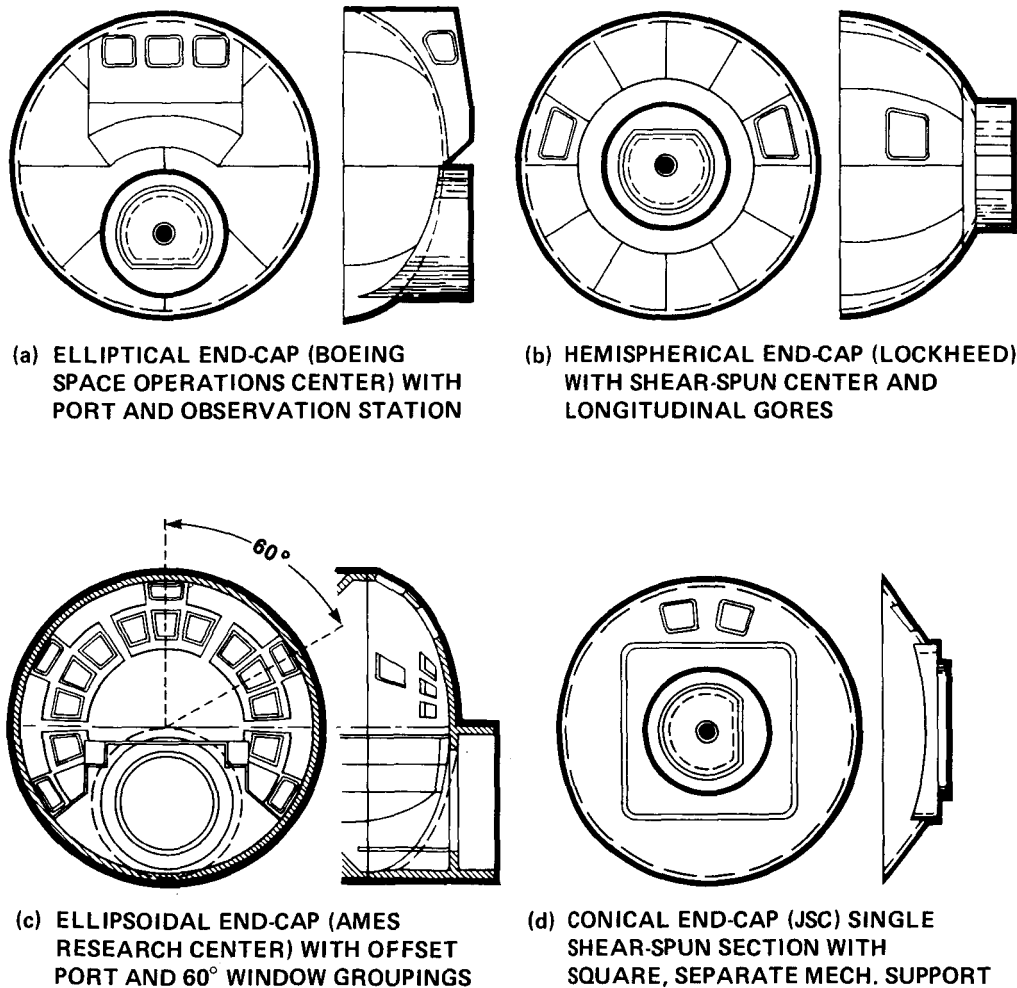

Figure 2.— Candidate end-cap geometries for supporting an array of PROX-OPS windows.

A list of human performance evaluation criteria related to window placement geometry suggested by Cohen of Ames Research Center (private communication, 1985) follows:

1. Window is axial or parallel to the docking vector (V).
2. Line of sight (LOS) is as near to normal to the V as possible.
3. FOV is maximally wide.
4. LOS is normal to the window whenever possible.
5. Angle between the LOS and window plane for narrow-angle viewing of distant targets (i.e., beyond about 820 ft (0.25 km)) is in the 60°–90° arc range.
6. Angle between the LOS and window plane for wide-angle viewing is in the 60°–90° arc range.

Each of the above performance criteria was compared by Cohen to each of the five end-cap geometries (each with two docking port location options) in table 1. It can be seen that the ellipsoidal end cap results in meeting the greatest number of positive criteria. The only candidate geometry that supports all of these criteria is the ellipsoidal end cap with an off-centerline docking port. The so-called rectangular cab is essentially a box structure added to the end of whatever shaped end cap is selected. The plane windows that would be installed in this box would be orthogonal to each other and therefore would provide only limited viewing angles between the LOS and window plane.

TABLE 1.—PRELIMINARY WINDOW GEOMETRY PERFORMANCE CRITERIA RATINGS

End-cap shape	Port location	1	2	3	4	5	6	Raw score ^a
Conical	On CL ^b	yes	no	no	no	yes	no	2
	Off CL	yes	yes	no	no	yes	no	3
Rectangular (Boeing)	On CL	yes	no	ltd	yes	yes	ltd	4
	Off CL	yes	yes	ltd	yes	yes	ltd	5
Hemispherical	On CL	yes	no	yes	no	ltd	yes	2.5
	Off CL	yes	yes	yes	yes	ltd	ltd	5
Ellipsoidal	On CL	yes	no	yes	no	yes	yes	4
	Off CL	yes	yes	yes	yes	yes	yes	6
Flat	On CL	yes	no	no	yes	yes	no	3
	Off CL	yes	yes	no	yes	yes	no	4

^aRaw score is unweighted and is for relative ranking purposes only.

^bCL = centerline, longitudinal axis of module.

A more recent module configuration for Space Station (fig. 3) is composed of connector nodes or hubs, and the end of each module in a so-called “figure eight” configuration (Riel et al., 1985). This module configuration is only of concern here as it influences window placement, size, shape, and external FOV.

In figure 4(a), the end of a single module and connecting node (from fig. 3) are shown attached to each other on the longitudinal centerline of the module. Based upon this geometry, the total FOV with the eyes setback 18 in. (45 cm) from an 18-in.-high (45-cm) window will be about 57°. The top of the connecting node will obscure the LOS (line E-F). If the same connecting node was placed off-centerline by even 3 ft, as is shown in figure 4(b), the available FOV will be approximately the same, but the viewer will be able to see

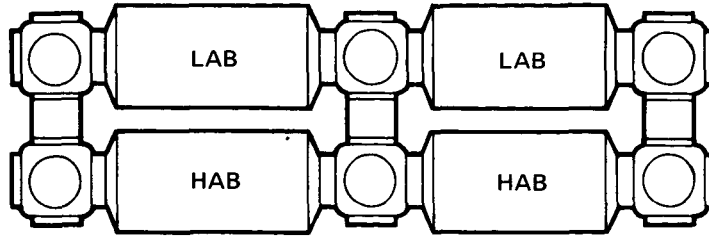

Figure 3.— Alternate "figure eight" module configuration.

down over the top of the connecting node about 10° . The significant advantage in increased total FOV for the off-centerline configuration becomes apparent when the eye is permitted to move anywhere within the DEV for a given window rather than considering a single DEP. The vertical FOV increases dramatically in this instance for the off-centerline configuration. This difference in "downward" visibility is due to the differences in end-cap geometry, as can be seen. The dimensions and geometry of the final design will establish true angular values. The shape of the windows would not necessarily be affected by either of the two designs. In summary, it is reasonable that a PROX-OPS station could be included at the end of a module that connects with a node if the connection is offset by an appropriate amount and the windows are arrayed in a fan around the remainder of the end cap.

2. SOLAR RADIATION, AMBIENT GEOMETRY, AND CYCLIC TIMING

Because windows admit sunlight into the Space Station, it is critically important to understand the nature of solar radiation as it exists outside Earth's atmosphere. This general topic is discussed here. Since Space Station will alternately pass in and out of Earth's shadow, the cyclic timing relationships with orbital altitude and inclination as well as the orientation of the Space Station relative to the sun and Earth must also be considered from the human factors standpoint. To the degree that human performance involves windows, the day/night ambient conditions are discussed here.

2.1 Basic Characteristics

Sunlight in Earth's orbit is not the same as sunlight at Earth's surface. The primary reason for this difference is the lack of intervening atmosphere, which absorbs and scatters wavelengths differentially. For the following discussions, it is assumed that the reader is familiar with basic terminology associated with luminous radiation. If not, several references will be found to be useful (Allen, 1963; Illuminating Engineering Society, 1942; Mechtly, 1964).

As Zink (1963) and others point out, the illuminance in the visible spectrum of sunlight increases by about 30% at orbital altitudes over illuminance values on a clear day at noon on Earth. "At 100,000 feet and 30 deg solar elevation, the intensity is about 13,500 foot-candles, which is comparable to that expected at orbital altitudes. In contrast to illuminance, zenith brightness of the daylight sky at 85 to 100 miles approximates a moonlit night and at orbital altitudes approaches total darkness, thus stars become visible."

One important consequence of the solar luminance characteristics on-orbit for window design is the ultra-high visual contrasts which exist in space — the so-called "searchlight effect." Even with fairly high interior illumination, sunlight entering a window will produce bright patches of illumination which will slowly sweep through the interior. If the viewer should happen to look directly at the sun, he or she will

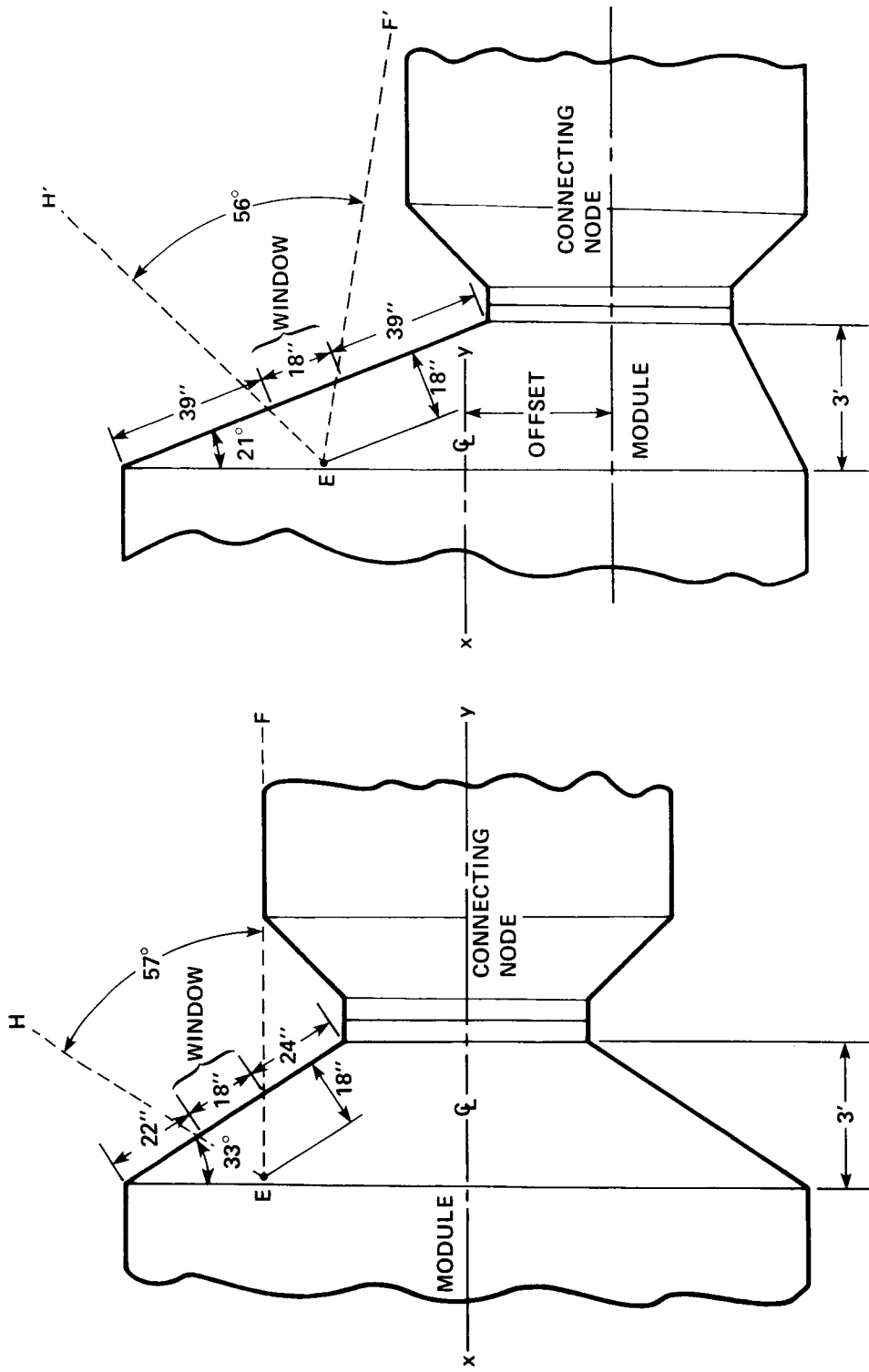

(a) On-axis connecting location.

(b) Off-axis connecting location.

Figure 4.— Two Space Station connection configurations.

experience temporary visual incapacitation. That is, the visual system requires time to become light-adapted. As will be discussed in section 2.2, the period between total darkness and full sunlight illumination (in low to moderate orbital altitudes) is approximately 1 min or less (depending upon orbital parameters). So-called "sky glow" at the Earth's horizon does increase the period of solar-related luminance at sunrise and sunset.

Since the human visual system requires several minutes to fully light-adapt to a very bright environment, there may be a period of less than optimal visual function (see fig. 10). Window layout, optical coatings, physical shielding, number of windowpanes, and other features will affect the degree to which the observer is incapacitated by this sudden brightening effect at sunrise. The opposite effect occurs at sunset, except that the visual system takes even longer to become fully dark-adapted (Craik and Vernon, 1941-42; Crook et al., 1953). Hecht and Hsia (1945) and Holly and Rogers (1982) have written on the continuing controversy over whether red or blue-white-hued illumination is to be preferred to maintain a state of relative dark-adaptation. Section 3.1.2 discusses this subject in more detail.

2.1.1 Radiation and Photometric Constants

Details of the major solar radiation constants are given elsewhere (see Allen, 1963; Fritz, 1951; Johnson, 1954; Schmidt, 1962; U.S. Standard Atmosphere, 1976; Braly and Heaton, 1972). Selected luminous and illumance characteristics of sunlight adapted from Allen (1963, pp. 168-169) follow:

Radiant Energy values:

Total integrated energy over all wavelengths as received outside Earth's atmosphere	1.99 (±0.02) Cal/cm ² /min 1.39×10 ⁶ erg/cm ² /sec
Radiation intensity at center of disk	2.49×10 ¹⁰ erg/cm ² /sec/sr
Mean radiation intensity within solar disk	2.04×10 ¹⁰ erg/cm ² /sec/sr
Emitted radiation from surface	6.41×10 ¹⁰ erg/cm ² /sec
Total candlepower	3.07×10 ²⁷ cd

Luminance values:

Mean disk luminance	2.02×10 ⁵ stilb 6.33×10 ⁵ L 5.88×10 ⁸ ftL 1.715×10 ⁸ Nits
At center of disk (from outside Earth's atmosphere)	2.52×10 ⁵ stilb 7.94×10 ⁵ L

Illuminance values:

Illuminance at mean solar distance (from outside Earth's atmosphere)	1.37×10 phot 1.37×10 ⁵ lx
--	---

Photometric unit conversions are provided elsewhere (Illuminating Engineering Society of North America).

The nature of the solar radiation curve as a function of wavelength is shown in figure 5 (adapted from Johnson, 1954). The solar spectrum is closely approximated by a Plank distribution corresponding to a (black body) temperature of 5800 K. As per NASA TM 86652 (1984, p. B-6), the thermal load on orbit is 443.7 Btu/ft²-hr. The sun's luminous radiation travels out from the sun radially and produces illuminance, the magnitude of which varies as the inverse square of the distance from the sun. The electromagnetic (EM) radiation from the sun and, to a far lesser extent, its particle radiation become the primary exciters of secondary sources of radiation such as heat. This occurs when the primary solar radiation is absorbed or scattered by matter in the solar system. In this report only visible-spectrum solar radiation is considered except

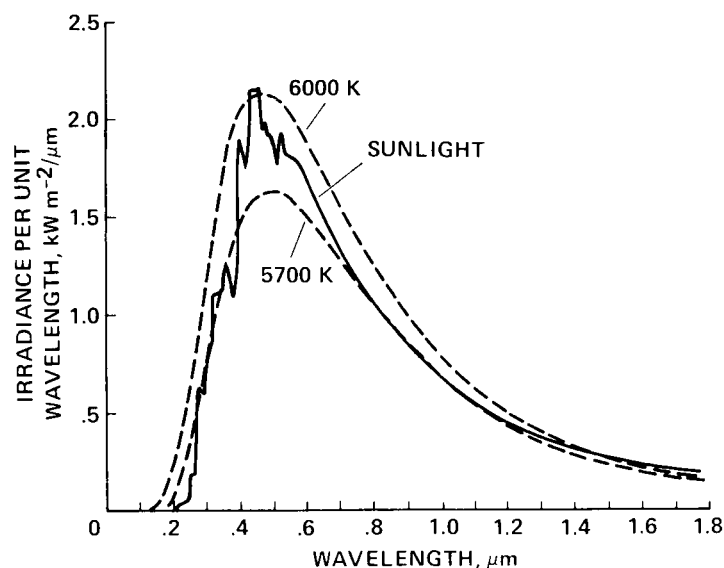

Figure 5.— The solar radiation curve.

where it can be shown that human performance is affected by other wave bands, e.g., if a window gets too hot the viewer may move away from its surface and reduce the external FOV coverage.

Thermal loads imposed upon windows in space can produce significant changes to the LOS through that window. A list of major sources of infrared radiation (heat) upon spacecraft windows is presented in section 5.3.

2.1.2 Angular Constants

At mean solar distance the sun's diameter measures approximately 32 min arc. Because of the annual variation in the distance between the Earth and the sun, this angle varies from 31.41 to 32.48 min arc. Thus, the collimation angle of sunlight is about 0.5° arc, a value that will be used throughout this report. The perceptual effect of this is that sunlight will enter each window much like a searchlight with sharply defined edges. High visual contrasts may be produced if the on-board illumination level is kept low. This sunlight should not be allowed to fall on flat surfaces having high reflectivity since they may redirect this searchlight beam in another direction. Temporary flash-blindness can result if a viewer is moderately to extremely dark-adapted and this sunlight enters his or her eyes. The interested reader may consult the following references related to this topic: Brown (1964), Cornsweet (1962), Miller (1965), Ritter (1961), and Strughold and Ritter (1960).

2.2 Temporal Characteristics

There are several temporal factors on-orbit that influence the design of PROX-OPS windows. They include:

1. Orbital parameters which influence the duration of flight in sunlight versus flight in the Earth's shadow
2. Stability of attitude of Space Station modules relative to the sun in those situations in which specular reflection of sunlight can enter one or more windows and visually incapacitate the viewer

3. Duration of sunset and sunrise
4. Duration of a viewing task when a high contrast is present within the FOV

Day/Night Orbital Durations. Table 2 presents some general values of duration of sunlight illumination (daytime) and flight in Earth's shadow (nighttime) for selected orbital parameters that bracket those of Space Station.

TABLE 2.—DURATION OF DAYTIME AND NIGHTTIME ON-ORBIT FOR SELECTED ALTITUDES

Altitude, n. mi	Period, hr	Maximum time in shade, hr	Maximum % of orbital period in shade	Minimum sun time, hr	66° Inclination, days		Maximum cycles/day
					Continuous sunlight	Continuous day/night	
200	1.53	0.610	39.4	0.92	0	183	15.5
300	1.58	.591	37.0	.99	0	183	15.0
500	1.72	.581	33.8	1.14	35	148	13.9

Sunset/Sunrise. The amount of time required for the full solar disk to disappear at sunset from the moment its limb is tangent to the horizon is approximately 8 sec neglecting the effects of airglow. The duration of light scatter within the Earth's atmosphere at between 200 and 300 n. mi. altitude will vary, but will be approximately 20 to 60 sec, as illustrated in figure 6. Since the solar disk is round and the Earth's horizon is very nearly a straight line, the temporal variation in illumination at the Space Station during sunset is approximated by one-half sine wave.

2.2.1 Orbital Inclination Parameters

The duration of solar illumination falling upon a Space Station on-orbit is partially a function of the angular inclination of the orbit, assuming that no parts of the Station's own structure blocks the sunlight and neglecting sunlight that is scattered by Earth's atmosphere. Table 2 provides selected values of the duration of day and night on-orbit for three altitudes and one inclination. The reader should consult McCanless et al. (1963) for more complete data.

2.2.2 Orbital Altitude Parameters

Current Agency plans call for a nominal altitude for Space Station of approximately 200–300 n. mi. above Earth at an inclination of 28.5°.

The Space Station's mean altitude above the Earth's surface will influence such parameters as:

1. Orbital velocity (depending upon orbital direction and inclination)
2. Amount of window area filled with Earth's surface (depending upon spacecraft orientation, etc.)
3. Time to view a given location on the Earth
4. Ability to discriminate objects on Earth's surface without optical aids (magnification)

The PROX-OPS windows will be used for Earth surface observation. Table 3 indicates time to view a given location on the Earth's surface as a function of orbital altitude assuming a fixed setback distance of 12 in. (30 cm) from the 7-in.-diameter (18 cm) window (equivalent to 16° 15 min arc diameter). It is also assumed that the viewer does not move his or her head and that the vehicle does not pitch to keep the location of interest in the window, but maintains a solar inertial attitude.

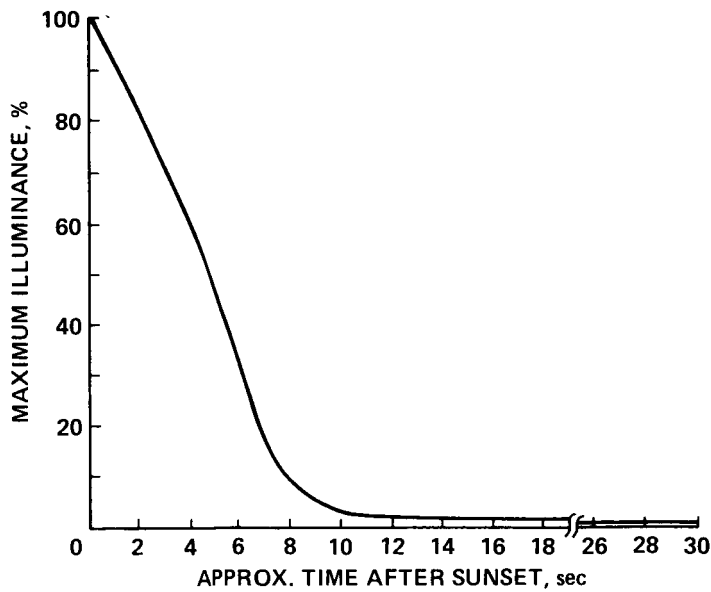

Figure 6.— Solar illuminance as a function of time during a sunset on-orbit.

TABLE 3.— TIME TO VIEW A GIVEN LOCATION ON THE EARTH AS A FUNCTION OF ALTITUDE

Altitude, n. mi.	Time to view, sec
100	36
200	44
300	55
400	70
500	89

TABLE 4.— SLANT ANGLE VISIBILITY FOR A 150-n. mi. ALTITUDE

Slant angle, deg (nadir to LOS)	t	S	g
0	0	150	90
5	3.3	151	84.8
10	6.6	152	79.6
20	13.6	160	69.1
30	21.9	175	58.5
40	31.9	198	47.9
50	46.2	241	36.9
60	69.8	323	25.3
70	130.5	554	11.3

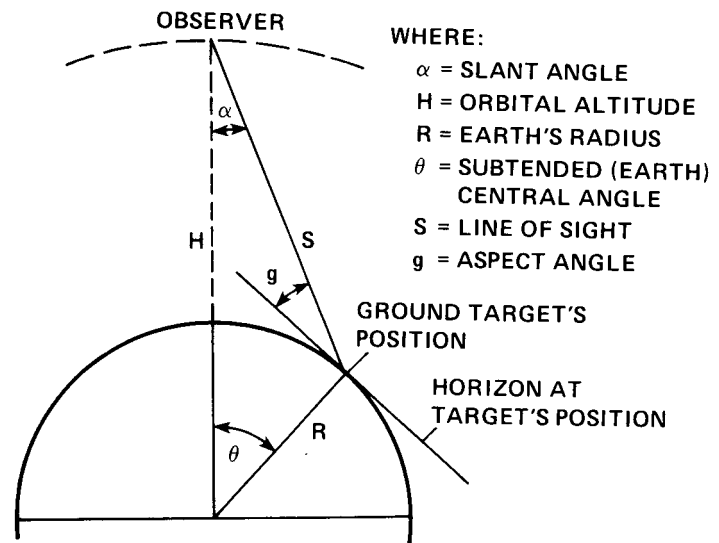

Figure 7.— Diagram of slant angle visibility parameters for on-orbit viewing of the Earth's surface.

Another consideration of being able to visually observe a given location on the Earth's surface is that of slant angle visibility. J. Malloy calculated the following values for a 150 n. mi. orbital altitude (Geometry of Horizontal Scanning From a Satellite, interdepartment communication, The Martin Co., Baltimore, Dec. 1960). The geometry for these calculations is given in figure 7.

The theoretical time to view (t) as a function of the slant range to the ground (S), aspect angle (g), altitude (H), and slant angle (α) are given in table 4 (as illustrated in fig. 7). For these values to be valid, the spacecraft must pitch nose-down at the proper rate to keep the point on the Earth centered in the window during period t . This will be accomplished if the Space Station is in a local horizontal/local vertical (LHLV) configuration.

One must also take into account several limitations on time to view and angular resolution of Earth surface detail imposed by (1) atmospheric visibility, (2) actual visual acuity of the viewer under flight conditions, and (3) optical characteristics of the spacecraft window. Each of these parameters can be subdivided into other factors that are beyond the scope of this paper.

When the LOS from the Space Station to the Earth's surface is not perpendicular, the distortions in depth and differences in the distance to the horizon become important. For instance, at a 60° slant angle, a nadir-to-Earth surface distance of 75 n. mi. becomes about 800 n. mi.; optical resolution drops dramatically because of many factors (Chorvinsky et al., 1961; Hardy, 1946; Taylor, 1964).

2.3 Earthlight and Moonlight

The total reflectance of the Earth integrated across the visual spectrum is known as its "albedo." Derivation equations for albedo are provided by Fleagle and Businger (1980). Average albedo takes into account solar irradiance, reflected solar irradiance, zenith angle, and orbital altitude. Values for the Earth's albedo have been published elsewhere (List, 1963); they take into account both cloud and Earth (terrain) reflectance. As flight crews on previous U.S. and Soviet missions have remarked, the Earth's surface is relatively bright, particularly when viewed against the total darkness of the space background, which enhances the apparent contrast even more. Considering that the luminance of sun-illuminated clouds as viewed from space is about 13,000 ft L (45,375 cd/m²), a window assembly having 80% transmission would still yield a luminance of 10,400 ft L (36,300 cd/m²), which is very nearly the luminance of a piece of clean white paper illuminated by the sun at noon on a clear day on Earth's surface. In short, one could read printed material on Space Station from full Earthlight. (See Hyle and Lunde (1968) for further information on the appearance of the Earth and Moon viewed from the Apollo 8 flight.)

Earthlight luminance also varies with phase (Jones, 1967), as is shown in figure 8 (adapted from Jones, 1967), which relates to a lunar surface vantage. At relatively low Earth orbits, this factor should play a relatively less important role than it would for greater distances.

In-flight Shuttle photographs are presented in figures 9 and 10 to illustrate the relatively great amount of illumination that will enter the PROX-OPS windows and the high-contrast shadows which will be produced by direct sunlight and reflected sunlight off cloud. Since the entire surface of the Earth is not covered with cloud, the Earthlight at the Space Station will vary over time by (perhaps) a factor of two or three. Sections 5.1 and 5.8 deal with means of controlling this luminance in the windows' angular field while section 3.1.2 deals (briefly) with interior mounted lights.

With regard to moonlight above Earth's atmosphere, the mean lunar albedo is about 8%, producing a luminance of about 1,000 ft L (3,490 cd/m²) (Jones, 1967; Koval, 1964). The illuminance produced by the moon at mean lunar distance is a function of lunar phase. Table 5 (from Brown, 1952) presents illuminance values.

In comparison, the lower limit for useful color perception is about 0.02 ft L (0.0057 cd/m²) and the absolute light threshold for the dark-adapted eye is about 9.6×10^6 ft L (3.2×10^5 cd/m²) according to Taylor (1973, p. 618). It is difficult even for young people to read black text on a white page under full moonlight and nearly impossible for middle-aged or older people to do so.

ORIGINAL PAGE IS
OF POOR QUALITY

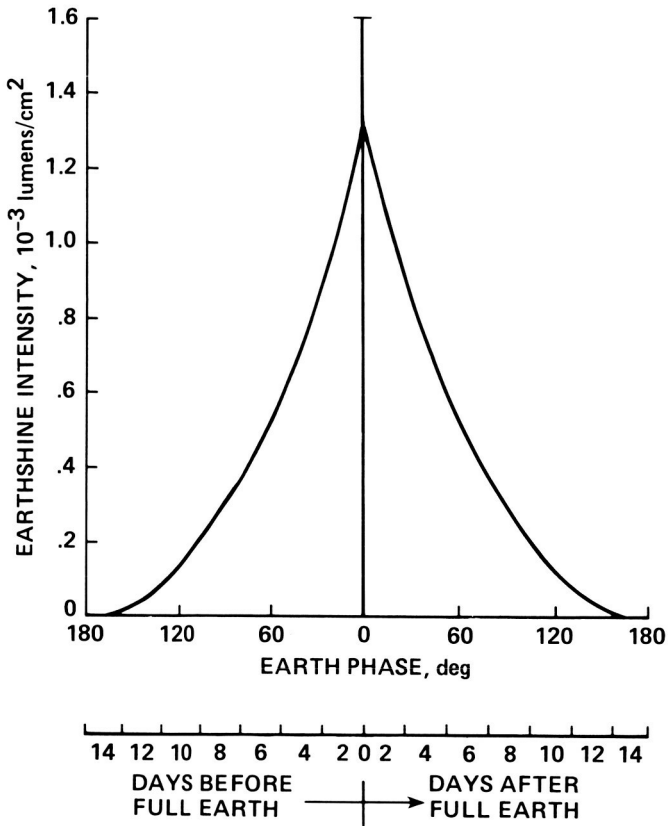

Figure 8.— Earthlight luminance as a function of Earth phase.



Figure 9.— Astronaut Joe Allen in Shuttle's aft compartment. Illumination produced by sunlight beam entering overhead windows (flight 51-A).



Figure 10.— Astronaut Dale Gardner looking out of the Shuttle's aft compartment overhead window; the high luminance is due to reflected sunlight off clouds (flight 51-A).

TABLE 5.— ILLUMINANCE PRODUCED BY LUNAR REFLECTED SUNLIGHT AT MEAN LUNAR DISTANCE AS A FUNCTION OF LUNAR PHASE

Phase, deg	Illuminance, ftc
0 (full)	0.0345
60	.0097
90 (half)	.0040
120	.0012

3. ARTIFICIAL ILLUMINATION GEOMETRY

3.1 Space Station Light Sources

As a general rule, the sources of artificial light should be attached to the Space Station if active control of the approach/rendezvous will take place from the Space Station. This is because the fixed angular relationships between the viewers' eyes and the light sources will provide consistent shadow structure changes with range and attitude changes. There will also be a perceptible increase in target surface illuminance as range decreases, which will provide further aid to the viewer(s). In short, the viewers will be better able to discriminate target object motions when the illumination geometry is a constant and is related to one's own vehicle than if it is under the dynamic control of someone else.

3.1.1 Exterior Mounted Lights

All floodlights mounted on the outside of the Space Station should be designed to prevent any direct light from entering any PROX-OPS windows.

Appropriate beam shape selection, fixture location, and aiming direction will be required in order to achieve this design objective.

Because of the presence of various flat, mirror-like surfaces on Space Station, it is possible that externally mounted floodlights will reflect back into one or more windows. Careful planning of the relative location of all light sources and reflecting sources is called for to keep this from happening.

Several areas of human performance would be adversely affected if illumination from floodlights fell upon PROX-OPS windows. They include:

1. Visual contrast of targets viewed through the window would be reduced, requiring either more target brightness to be seen and/or closer range.
2. Veiling glare within the FOV would tend to produce visual fatigue and eyestrain.
3. Pupil diameter would decrease on the average (with consequent increase in the depth of field).

3.1.2 Interior Mounted Lights

While this subject is treated in greater detail under the habitability and architectural discussions of Space Station, some mention must be made of artificial light sources inside the PROX-OPS station as they relate to (1) the visibility of the target vehicle seen through the windows, (2) the visibility of displays and controls within the PROX-OPS station that will be associated with the windows, and (3) the visibility of the

Space Station as viewed from the target vehicle. Maintenance of the viewer's dark-adaptation state after he or she has been in darkness for even 10 min is important if he or she is going to be looking outside to locate dim targets. A traditional approach has been to use a dim red floodlight which reflects off controls and displays. It is suggested that this approach should be followed only when the viewer must maintain full dark adaptation and must also be able to see interior details.

During all other periods, the general ambient illuminance should be white at from 100 to 500 lx (10 to 50 ftc).

Self-luminous displays such as cathode ray tubes (CRTs) or plasma tubes should be capable of being dimmed to suit the prevailing interior illuminance to achieve best contrast.

3.2 Shuttle (or "Active" Moving Target) Light Sources

The primary issue here is whether the person controlling the approach or departure is on the Space Station or on the active target vehicle. Maintenance of optimal illumination is essential in order to provide stable visual cues to the viewer, i.e., cues that do not change significantly over time or with changes in the relative orientation of the two vehicles. The axis between the sun and Space Station will change slowly and regularly at about $4^\circ/\text{min}$ if an LHLV orientation is maintained. A berthing operation lasting 15 min will involve a sunline change of about 60° , which can be expected to produce potentially misleading shadow pattern changes.

Computer simulations should be conducted to show, in advance, the nature of external-view shadow patterns for each candidate configuration of Space Station modules and berthing vehicles as a function of possible sunlines.

4. HUMAN OBSERVER TASKS AND RELATED WINDOW DESIGN REQUIREMENTS

A wide variety of tasks will be carried out at the PROX-OPS station within the Space Station. They may be subdivided into two basic categories:

1. Proximity operations of transfer vehicles and the Orbiter with the Space Station as the central vehicle
2. Proximity operations of the transfer vehicles and the Orbiter with the free-flyer-class payloads as the central vehicles

Within each of the above two operational categories are two subdivisions: (1) deployment/separation profile, and (2) approach/return profile. As discussed in detail elsewhere (Donahoo and Anderson, 1985), these profiles will help determine such design features of the Space Station as the number and location of berthing ports, traffic-control procedures, communication patterns, and future Space Station expansion.

In this section a number of human factors design trade-off parameters are presented as related to PROX-OPS windows. Sections 4.4.1 through 4.4.4 deal with geometric variables which are shown to influence the available FOV of one or more windows. Section 4.5 presents selected laboratory vision data concerning the normal human visual system's distribution of spatial (acuity, motion sensitivity, etc.); and intensity (light sensitivity, color sensitivity, etc.) parameters within the FOV. Such data can be used to evaluate one candidate window design against another.

4.1 Selected "Return/PROX-OPS" Maneuver Requirements

The PROX-OPS window array must support the critical return/PROX-OPS procedures, which fall into two general categories: (1) manual control of the approaching vehicle (Orbiter) or target object (structural member, etc.) and (2) monitoring of automatic guidance and control equipment and related displays. The first category will be called "manned active approaches" in following sections of this report; the second category will be called "unmanned approaches."

From a human factors standpoint, the astronaut has to successfully complete a number of visual, cognitive, manual, and other tasks in order to complete a manned active approach. Table 6 summarizes the major visual tasks and stimulus characteristics during selected phases of an approach (adapted from Pennington and Brissenden, 1963).

TABLE 6.— MAJOR VISUAL TASKS INVOLVED IN A RETURN/RENDEZVOUS MANEUVER

Phase of return/rendezvous	Visual task(s) involved	Stimulus characteristics
Initial visual acquisition (task becomes one of recognizing some critical feature)	Sensory detection	Intensity, relative motion, flash-rate, color, unique spatial location, etc.
Establishment of correct intercept trajectory	Apparent (frontal-plane) vector rate	Motion cues (rate, acceleration, and apparent vector)
Range and range-rate determination	Angular velocity and rate discrimination	Motion cues (rate, acceleration, vector, size/shape change cues)
Braking/deceleration	Range and deceleration-rate judgments	Apparent size change rate, shape change judgments
Final berthing/contact	Target attitude and range/range rate judgments relative to own docking port	Target edge/detail discrimination, surface texture cues, shadow location, and variations over time

Well-designed windows must support all of the above visual, cognitive, and manual operations involved in all five of these phases of a return/rendezvous.

The initial visual-acquisition phase may well assume a less critical role as radar-based acquisition equipment is placed into service, particularly as the concept of a "Space Traffic Control" center is developed. Nevertheless, the crew may still want to assist in this operation from the Space Station. The windows' transparency, individual FOV, and directions of view of the entire array of windows are three primary human factors design characteristics of importance.

A distant space vehicle may reflect sunlight or emit its own light toward the Space Station. Even for extremely large reflecting areas such as solar arrays, the source will act as a point source (i.e., it will have no apparent area) and will produce illumination at the Space Station as the inverse square of its distance away. Consequently, it may appear like another star (when seen against the sky background) or it may not be visible if seen against the Earth background (under certain orbital conditions).

Stellar Visual Magnitude. Because observers must be able to visually detect very faint point light sources against a star field, it is important to have some idea of stellar visual magnitudes. The visual magnitude (M_v)

of a star is not related to the luminous energy possessed by the star, but to the amount of *illumination* it provides at the measurement position (eye). Each succeeding magnitude contains stars fainter than those preceding them. If two stars differ by an entire magnitude, the lower-magnitude star differs from the higher by 2.5 times its brightness. Knowing the illuminance of a star of given M_v , then, it is possible to calculate the illuminance of any M_v star using the expression (from Hyman, 1963):

$$M_v = -2.5 \log E_m - 16.72$$

where M_v equals visual magnitude and E_m equals the illuminance from the star (in foot candles). An illuminance value of 3.90×10^{-8} ft c for a star of $M_v = 2$ is cited by Allen (1963) and is preferred here. Other values cited in the literature range from 3.08×10^{-8} to 3.9×10^{-8} . By knowing the illuminance level of various point light sources, one can better specify the optical characteristics of windows through which one is searching for the faint, tiny point sources of light.

The difference in brightness of different stars is apparent both on Earth and in orbit. Indeed, constellations are partly recognized on the basis of their different brightness (and pattern). Since a target vehicle will increase in brightness as its range decreases, it is important to understand how such man-made light sources may be differentiated from the star background whose apparent brightness will not change over time. A useful law in this regard is the "2.5 times" law mentioned earlier. Thus, a lower-magnitude star differs by 2.5 times the brightness of a higher-magnitude star (only for whole M_v differences). Table 7 presents these ratios for brightness differences of from one to five.

TABLE 7.— VISUAL-MAGNITUDE-
BRIGHTNESS-DIFFERENCE
RATIOS

M_v difference	Brightness ratio
1.0	$2.512 = 2.512^1$
2.0	$6.31 = 2.512^2$
3.0	$15.85 = 2.512^3$
4.0	$39.8 = 2.512^4$
5.0	$100.0 = 2.512^5$

It has been estimated that an astronaut can be expected to see a star of $M_v = 6$ (or brighter) within 2° arc of his or her target (Pennington and Brissenden, 1963). The faintest star that would be visible to the unaided eye as an individual target would have an M_v between 5 and 6 (Roach and Smith, 1964). These illuminances are approximately equivalent to that produced by one candle at night at a distance of approximately 4 mi. (6.4 km). Based on psychophysical data and optical theory, given sufficient viewing time, we assume that the normal visual system could perceive an isolated star of $M_v = 8.5$, which is equivalent to the illumination from one candle at a distance of about 13 mi. (21 km). The visual background would have to be totally dark, however. (If this star is embedded within a star field, this perceptual ability is reduced to about $5 < M_v < 6$.) This reduction is the result of the raised visual threshold (reduced sensitivity) caused by integrated starlight from all stars within one's FOV. If other sources of light are present within the FOV, even fewer stars can be seen. More information may be found elsewhere (Heinisch, 1971; McCanless et al., 1963). This is one reason the PROX-OPS windows should have as high an optical transmission as possible in the visible spectrum.

Some mention needs to be made regarding the density of stars of different visual magnitudes. McCanless et al. (1963) is an excellent source of such information. Table 8 is taken from this reference.

TABLE 8.— DENSITY OF STARS HAVING DIFFERENT VISUAL MAGNITUDES

M _v	Number stars/square deg brighter than M _v	Square deg/star brighter than M _v	Number stars in a 227 square deg field brighter than M _v ^a
3	0.0014	227	1
4	.013	77	3
5	.04	25	9
6	.12	8.3	27
7	.3	2.94	77
8	1.00	1.00	277

^aThis corresponds to a circular FOV of 17° diam or a square FOV of about 15°/side.

Table 8 indicates that if the viewer were searching for a target vehicle of M_v = 6, through a single window whose area is 227 square degrees, there would be about 27 stars brighter than the target. This suggests that a flashing acquisition beacon would be a valuable addition to the target vehicle and the Space Station.

Dark Adaptation. The visual system does not adjust immediately to a change in brightness of a target or the ambient surround. Indeed, the larger the brightness difference, the longer the visual system requires to achieve a stable, "optimal" level of sensitivity. Many investigators have quantified this effect (see the bibliography on dark adaptation by Crook et al., 1953). Figure 11 presents visual sensitivity in log-effective foot candles and time in the dark in minutes (from Craik and Vernon, 1941-42). It is seen that not until about 20 to 30 min have passed in the dark does the eye begin to approach its maximum sensitivity to light. The implication of such data for Space Station window design should be obvious. First, the windows should not reflect on-board ambient illumination into the viewer's eyes. Second, any special surface coatings on the panes should not contribute to veiling glare within the viewer's FOV. Third, the apparent position of the tiny target vehicle should be kept approximately centered in the window to prevent decrements in brightness sensitivity caused by adjacent window-frame effects (Lamar et al., 1947). Additionally, the time on orbit at which initial visual acquisition of a distant target vehicle should take place is when the eyes have been dark-adapted for as long as possible. This may call for the PROX-OPS area to be kept in relative darkness with only dim red illumination.

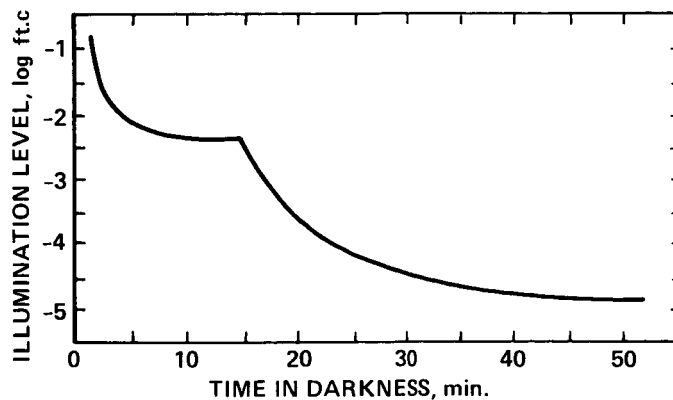

Figure 11.— Rate of dark adaptation.

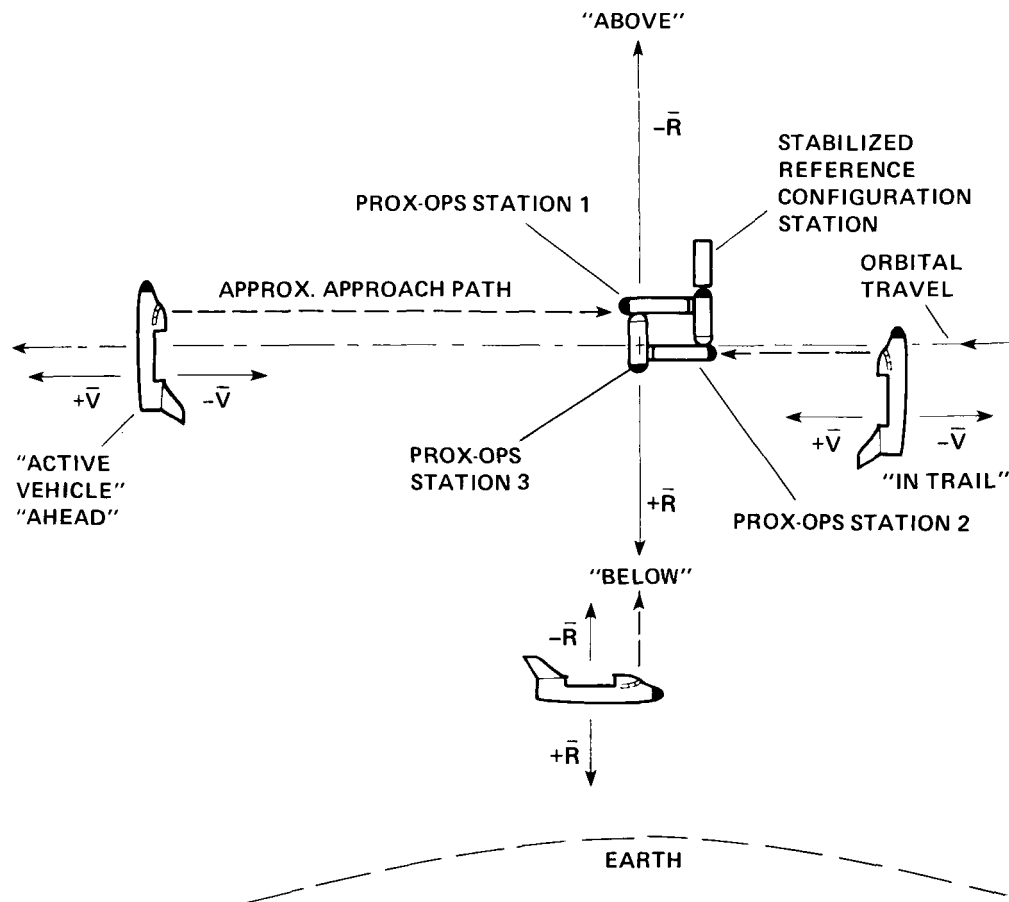

Figure 12.— Orbital parameters related to PROX-OPS.

4.1.1 Manned Active Approaches

Before this section is presented it is important to define certain terms that will be used. Figure 12 illustrates the Space Station with the Earth below and the orbital direction of travel to the left. From a human factors standpoint, all final approach/departure operations are assumed to lie within the orbital plane since the magnitude of visual translation of the Shuttle seen within the Space Station's PROX-OPS windows will be extremely small. Definition of an approach/departure direction is typically referenced to an LVLH coordinate system (relative to the Space Station) where vertical "down" $+R$ is with respect to the center of the Earth and "up" or "above" is referred to as $-R$. Therefore, in figure 12, if the active vehicle is to the left of the stabilized target vehicle (Space Station), it is said to be "ahead"; if it is to the right, it is "in-trail." Plus and minus V are always relative to the direction of orbital travel as shown. Use of an LVLH coordinate system requires that the Space Station pitches about the Y axis 360° /orbit. The significance of all of these terms from the human factors viewpoint has to do with the appearance of relative motion of the target vehicle within the PROX-OPS window(s).

Donahoo and Anderson (1985) suggest that if one of the vehicles involved in the PROX-OPS activity is manned, the lighting should be in the direction favorable to the manned vehicle. This requirement affects not only the attitude of the manned vehicle, but (for the Space Station) certain window design characteristics such as glare-reduction coatings, shutters, or other light-controlling means. The $+V$ of the target (Space Station) should be used for manned active approaches to keep the sun "over the shoulder" of the Shuttle

crew (assuming they are controlling the approach). This course will cause the sunlight to fall directly onto one or more PROX-OPS windows.

4.1.1.1 LVLH Radius Vector (\pm)

In a $-R$ approach the PROX-OPS end cap would face away from the Earth's surface throughout the orbit, and the active vehicle would approach from below initially. On the day side of the orbit, the active vehicle would be viewed against a potentially bright Earth background, which would tend to make it difficult to discern surface details facing the Space Station because of veiling glare and associated contrast reduction. On the night side of the orbit, auxiliary floodlights would be needed on the active vehicle, and appropriate running lights would be needed on the target vehicle (see sections 3.1 and 3.2).

In a $+R$ approach the active vehicle would approach from below so that the Earth's surface will form the visual background. On board the stabilized target vehicle the viewer's side of the approaching vehicle may be illuminated by Earthlight or by sunlight, or it may be in total darkness so that special floodlights are needed.

The motion of the active vehicle relative to the Space Station for close-in maneuvers from the $-\bar{R}$ and the $+\bar{R}$ vector-berthing port are given by Donahoo and Anderson (1985), figures 6-4, and 6-3, respectively, which are reproduced here as figures 13 and 14.

Point 3 in figure 13 is 1,117 ft (344 m) from the Space Station at an angle of 40° arc below the local horizontal (X) axis. Since the active vehicle moves from a position ahead of the Space Station to a position behind it, it will not be visible continuously from the same PROX-OPS windows. As is shown, the active vehicle passes under, behind, above, and then back down to the $-\bar{R}$ berthing port. The two PROX-OPS stations illustrated in figure 1 would not (directly) support this type of approach because of their orientation and the fact that their FOV does not extend far enough in the direction of this berthing port. At the point in the PROX-OPS window facing forward where the 122-ft-long (37-m) Shuttle just disappeared, it would subtend an angle of 24° end-to-end.

At point 2 the Shuttle would subtend about 47° arc. The fact that certain approaches will cause the target vehicle to disappear from view will call for creative approaches to visualizing three-dimensional space continuously. Computer-generated, three-dimensional, symbolic displays may play a useful role here.

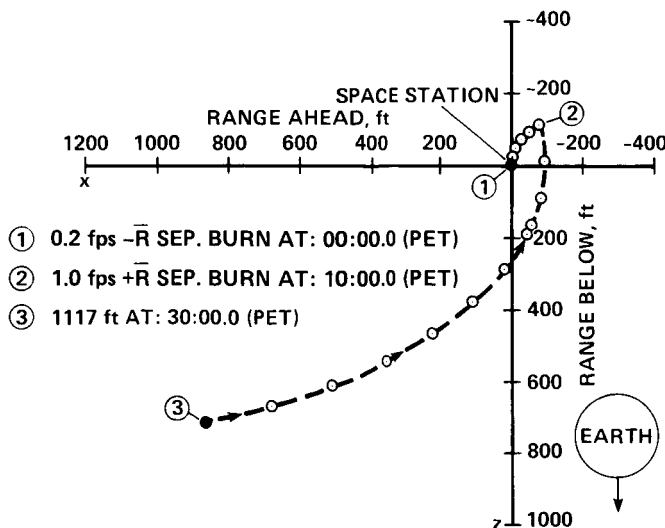

Figure 13.— Motion of the active vehicle relative to the Space Station for close-in maneuvers from the $-\bar{R}$ vector berthing port.

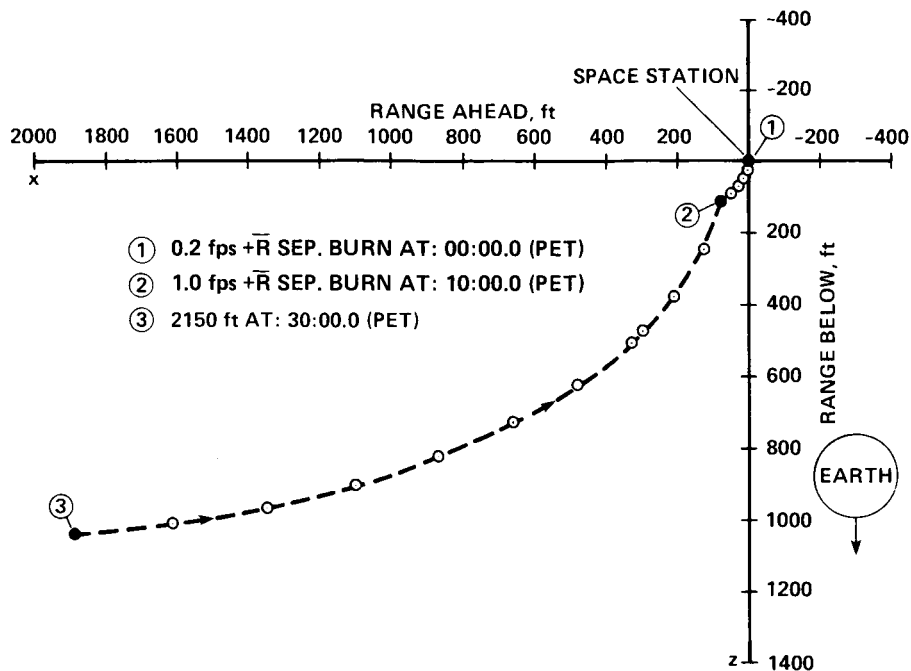

Figure 14.— Motion of the active vehicle relative to the Space Station for close-in maneuvers from the \bar{R} vector berthing port.

During the approach shown in figure 14, the active vehicle would be seen about 30° below the local horizontal (X) axis at point 3, a range of 2,150 ft (662 m). The vehicle would continue to drop in the window to a maximum depression angle of about 64° , after which it would rise almost radially toward the Space Station. Only the last 20 ft (6.2 m) or so would be directly along the \bar{R} vector. At point 3 the Shuttle would subtend 3.2° arc while at point 2 it would expand to an apparent 47° arc. In summary, the active vehicle would remain visible continuously within a cone of vision of about 30° and would appear to enlarge. Appendix B in Donahoo and Anderson (1985) presents computer plots of LOS range versus time and range rate versus time, as well as other related parameters which help to visualize the out-the-window appearance of selected approach conditions.

Both the horizontal and vertical total angles of view through all PROX-OPS windows must accommodate all of the anticipated kinds of approaches and departures.

4.1.1.2 LVLH Momentum Vector (\pm)

Motion of the active vehicle relative to the Space Station for close-in separations from the “minus angular momentum vector” berthing port is shown in figure 15 (from Donahoo and Anderson, 1985). The right side of the figure represents the in-orbital plane motion and the left side represents the out-of-plane motion. Point 3 lies 1,635 ft (503 m) from the Space Station and 33° below the local horizontal. The Shuttle would subtend an angle of 4.3° arc at this position. The relatively small out-of-plane motion would appear from the PROX-OPS windows as a slight lateral translation of only a few degrees. During this approach the active vehicle would appear to drop lower and lower within the window and yet become larger and larger. An auxiliary alignment (HUD) symbology would appear to be needed under such conditions to support accurate visual perception of range and range rate.

The close-in motion of the active vehicle relative to the Space Station for the “plus momentum vector” berthing port is presented in figure 16 (from Donahoo and Anderson, 1985). The in-plane motion is the same as for the “minus angular momentum vector” while the out-of-plane shift is to the opposite side of the Y plane. The same general comments apply for both figures.

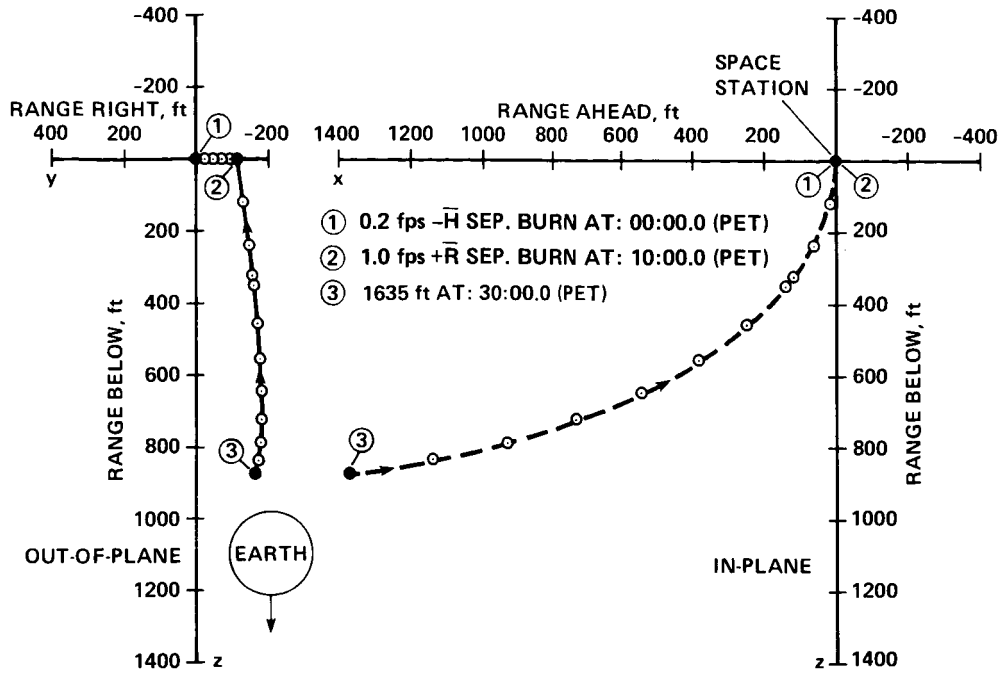

Figure 15.— Motion of the active vehicle relative to the Space Station for close-in maneuvers from the minus angular momentum vector berthing port.

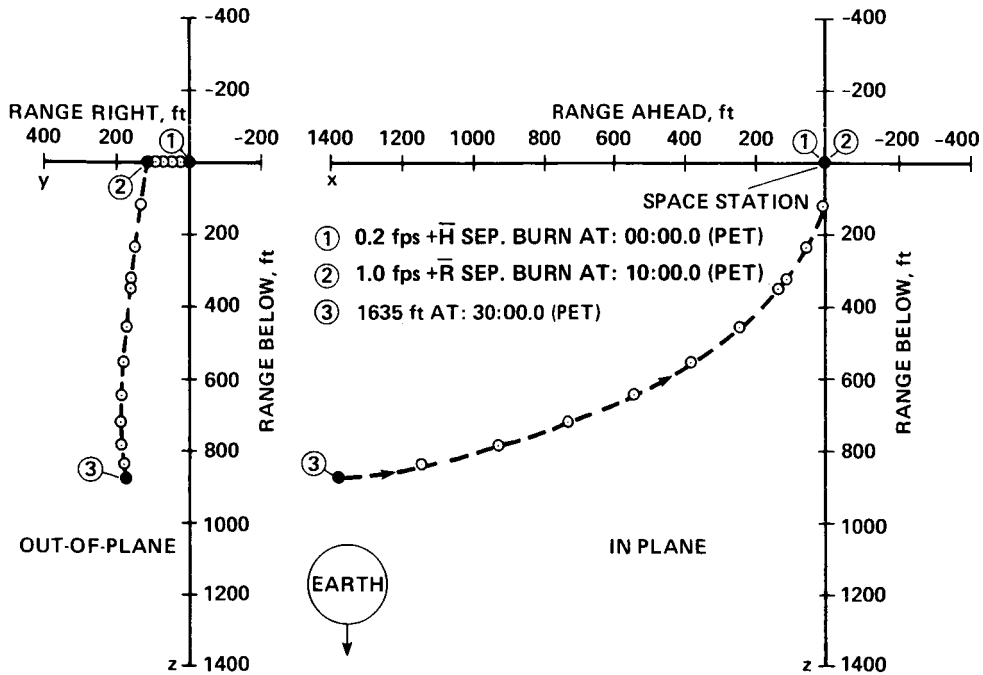

Figure 16.— Motion of the active vehicle relative to the Space Station for close-in maneuvers from the plus angular momentum vector berthing port.

4.1.1.3 LVLH Velocity Vector (\pm)

The close-in motions of the active vehicle for the $-\bar{V}$ and the $+\bar{V}$ approaches are diagrammed in figures 17 and 18, respectively (adapted from Donahoo and Anderson, 1985, figs. 6-2, 6-1). Both are in-plane. Each presents an interesting translation of the active vehicle across the PROX-OPS windows, as will be discussed.

The active vehicle (see fig. 17) will be visible first within PROX-OPS station 1 windows (see fig. 1) and then within PROX-OPS station 2 windows. It will pass under Space Station at a range of about 400 ft (123 m) where it will subtend an angle of 17.3° arc. It will then appear to move rapidly upward in the window through a total arc of about 90° , making its final approach along the X axis. Some means of visually monitoring the approach will be needed when the active target vehicle is not directly visible through either of the PROX-OPS windows. This raises the important issue of PROX-OPS blind spots surrounding the Space Station.

To support the basic design objective of total situational awareness by the viewer, there should be no blind spots surrounding the Space Station.

Exactly how this requirement is best accomplished will depend upon the results of tradeoff studies between window parameters and closed-circuit TV parameters.

The active vehicle (see fig. 18) will appear centered laterally within a forward-facing window and about 21° arc below the local horizontal at point 3, some 1,018 ft (313 m) away. A Shuttle will subtend an angle of approximately 7° arc here. As it continues its approach, it will appear to drop to 40° arc below the local horizontal while appearing larger and larger. After reaching its maximum depression angle, at a range of about 365 ft (112 m), it will begin to rise in the window until it is about 40° above the local horizontal. The total vertical angle will be about 80° arc, a fact which would affect the viewer's eye-to-glass setback distance, window dimensions, and other factors discussed in section 4.4.

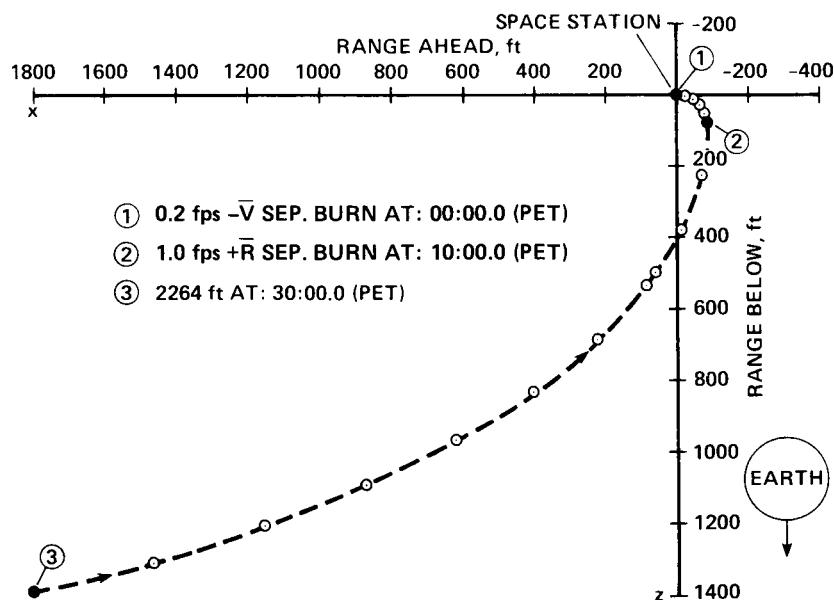

Figure 17.— Motion of the active vehicle relative to the Space Station for close-in maneuvers from the minus velocity vector berthing port.

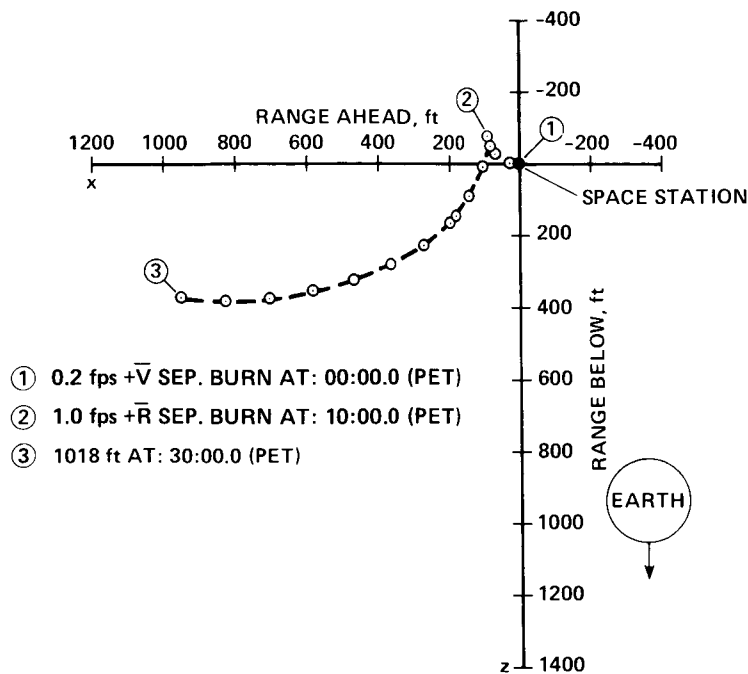

Figure 18.— Motion of the active vehicle relative to the Space Station for close-in maneuvers from the plus velocity vector berthing port.

4.1.2 Unmanned Approach to Manned Space Station

“Active unmanned vehicle approaches to free-flyer payloads will be initiated ahead of the target (free flyer) in the same manner as discussed previously for manned active vehicles” (Donahoo and Anderson, 1985). This will help optimize the illumination direction and also permit better visual judgments of range, range rate, and attitude changes. It is assumed that the free flyer will have appropriate sensors for six degrees of freedom of motion which will be displayed aboard the Space Station and through which the final approach will be controlled.

4.2 Special “Deployment/Separation” Maneuver Requirements

Plans call for a mechanical ejection or a remote manipulator release of the berthed vehicle, followed by an initial small maneuver that will produce a separation rate of about 0.2 ft/sec (0.06 m/sec). After additional maneuvers and coasting (perhaps lasting 10–20 min), a major separation burn is carried out to place the vehicle outside the explosion range and/or plume damage area. These actions are followed by an orbital transfer burn, as needed. The direction of the initial separation maneuver will be directly away from the berthing port to maximize an opening rate. Viewed from inside the PROX-OPS station, the only visible change in the departing vehicle should be a reduction in apparent size. Use of a locally stabilized reticle pattern may be useful in monitoring this departure. Research has shown that pilots can perceive closure rates of small targets with sufficient accuracy to support most PROX-OPS (Brissenden, 1962; Brissenden and Lineberry, 1962).

4.3 Space Station Construction Activities

To the extent that any PROX-OPS window already happens to face a direction that includes construction (build-up) activities, viewers can monitor this activity. For example, if a remote manipulator (RM) arm is to be controlled from a PROX-OPS station for berthing and departure operations, the RM may also support construction activities.

PROX-OPS windows should be designed to support major, long-term PROX-OPS functions and periodic scientific experiments, and not be changed merely to support near-term or construction-related activities.

4.4 Human Factors Design Tradeoff Parameters

There are numerous human factors parameters that may be used to carry out tradeoff studies for PROX-OPS windows (Haines, 1985). I considered the parameters presented below to be the chief ones. Many other parameters had to be omitted because of the limited scope of this report.

4.4.1 Window (Linear) Dimensions

The width of each window is one of the most critically important design features. As indicated in Section 1.3, a maximum window dimension (for flat glass) of 20 in. (51 cm) is assumed in this report. Larger windows will permit a wider FOV for a single viewer as well as more viewers per window. Use of a convex "bubble" window will also afford a wider FOV, but it will introduce numerous optical and perceptual problems, including

1. LOS deviation as a function of the eye location relative to the center of curvature of the bubble (see section 5.3)
2. Surface reflections that are not necessarily representative of the light source(s) being reflected (see section 5.7.2)
3. Possible image magnification or minification (see section 5.5)

It is for the above reasons that the following guidelines are presented.

PROX-OPS windows should contain only flat glass panes.

The required maximum FOV angle should determine window width, and not vice versa.

4.4.2 Eye Distance to Inner Pane (Setback)

The term *design eye point (DEP)* is used here in the same way it is used in the design of airplane cockpits; that location in space which represents the mean location between the observer's eyes when he or she is seated in some desired position. The lack of body support-restraint in microgravity will necessarily require enlarging the DEP into a DEV. The DEV shall be 0.4 m³ in total volume whose geometric center shall lie on the observer's LOS normal to the windowpane and penetrate the pane at its center. The center of the DEV shall be such that an eye-to-window-surface setback distance of no less than 4 in. is allowed. And the fact that observers can place themselves into almost any orientation with respect to the window aperture raises challenging design questions concerning the size and shape of each window. In this section setback distance will be discussed.

4.4.2.1 Anthropomorphic Considerations

This section deals with the subject of human body measurements and natural postures in microgravity, with specific regard to the design of PROX-OPS windows. Since the body assumes an approximate bent-trunk, knees-tucked, head-forward posture in microgravity (Jackson et al., 1975), the average LOS of the viewer is depressed about 20° arc downward from the standing-erect posture in a 1-g environment. Figure 19 (from Jackson et al., 1975, fig. 11) shows that while the head-neck axis may tilt back about 20° to 24° the LOS can be raised through larger vertical angles because of eyeball rotation. Neck-flexion angle can become an important (and painful) concern if it must be sustained for long periods of time. It can also be noted that certain visual judgments may be influenced by the prolonged muscular tension that will be needed to hold the head back or to one side. For example, the perception of the visual vertical is biased in the clockwise direction if the head is voluntarily maintained in the upright position against a force that is applied from the right side of the head, and vice versa (Schneider and Bartley, 1966). This effect has come to be known as the sensory-tonic effect.

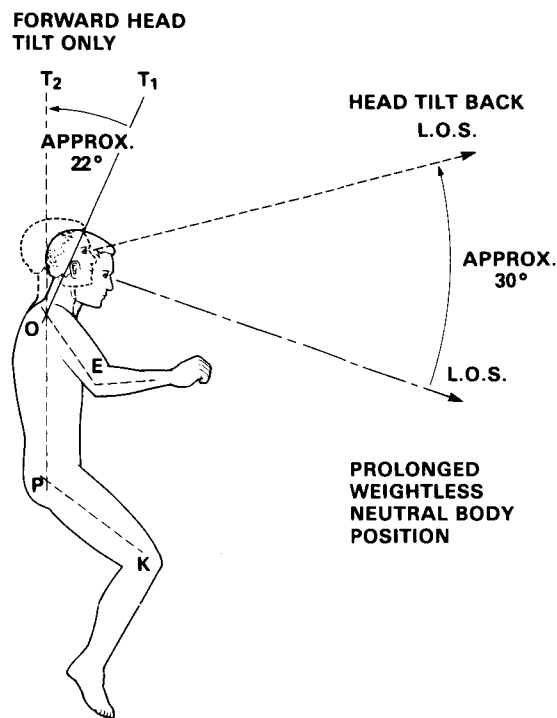

Figure 19.— Approximate weightless neutral body position.

Another anthropomorphic consideration of the eye-to-window setback distance is arm reach. With the eyes located at a given DEP which permits the required total FOV per window, the nominal arm-reach distances are as shown in figure 20 (adapted from the U.S. Air Force Human Factors Design Handbook (1984)).

4.4.2.2 Surface Contamination Considerations

Another important consideration regarding the setback distance is concern over surface contamination. One form of contamination is condensed moisture from one's breath.

It is recommended that the innermost pane be heated such that breath condensation does not occur from a mouth-to-pane distance less than 4 in. (10.2 cm).

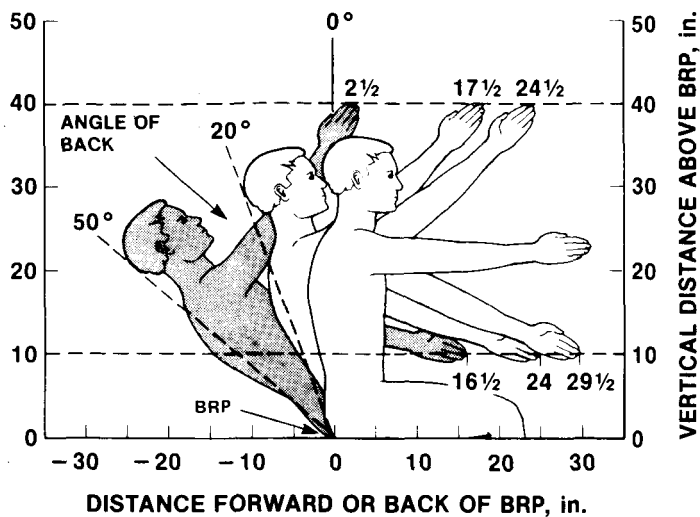

(a) Maximum forward reach with different backrest angles and vertical distances above the body reference point (BRP), with 0° arm angle.

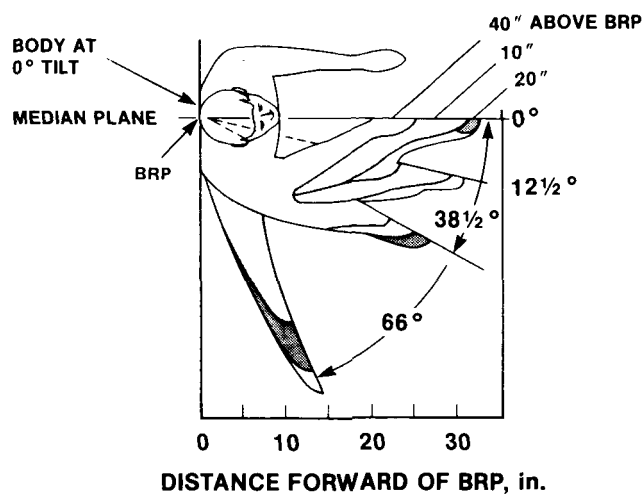

(b) Maximum forward reach with different arm angles and vertical distances above the BRP, with 0° backrest angle.

Figure 20.—Nominal arm reach for three upper-body angles.

4.4.3 DEP Lateral Offset From Window Centerline

The lateral offset distance (inches) of the eyes from the center of a window is one of the critical parameters affecting the width of the external FOV. As is shown in figure 21, other parameters include the setback distance, bezel thickness, and width of the window.

Trigonometric calculations have been made of the visual angle (deg) across each of three window widths (9, 18, and 48 in. (23, 46, and 122 cm)) as a function of lateral offset position of the eyes, ranging from 0 (on window centerline) to more than 35 in. (90 cm). These results are presented in figures 22, 23, and 26–28; each figure is for a different setback distance.

Figure 24 illustrates the fact that for a concave, ellipsoidal end cap and a 12-in. (30-cm) setback distance, the body axis O-P-K will necessarily be straighter than for a larger setback distance (see fig. 25 for a 22-in. (56-cm) setback).

It may be noted from figures 22–28 that at any given setback distance, FOV decreases as the eyes are moved farther from the window's centerline, and the rate of angular decrease of FOV at any setback distance varies with window width. Larger-width windows yield a somewhat faster rate of FOV decrease as a function of lateral offset. For any given window width, decreasing the setback distance produces an increase in available external FOV. With the eyes located at the edge of a single window (lateral offset equals one-half the window width), smaller setback distances produce significantly faster decreases in visual angle as the head is moved beyond the edge of the window. This finding may have important implications for how window shape and gap-width parameters may be varied to reduce head movement when the viewer is tracking a target that is moving past the window(s). These figures may also be used in conjunction with data presented later (section 4.5) dealing with the angular extent of various kinds of visual sensitivities from the LOS (fovea). If it is determined that the viewer must have a FOV through any single window of, say, 90°, then a horizontal line drawn through 90° in these figures will indicate the required window size and other parameters needed to achieve this FOV.

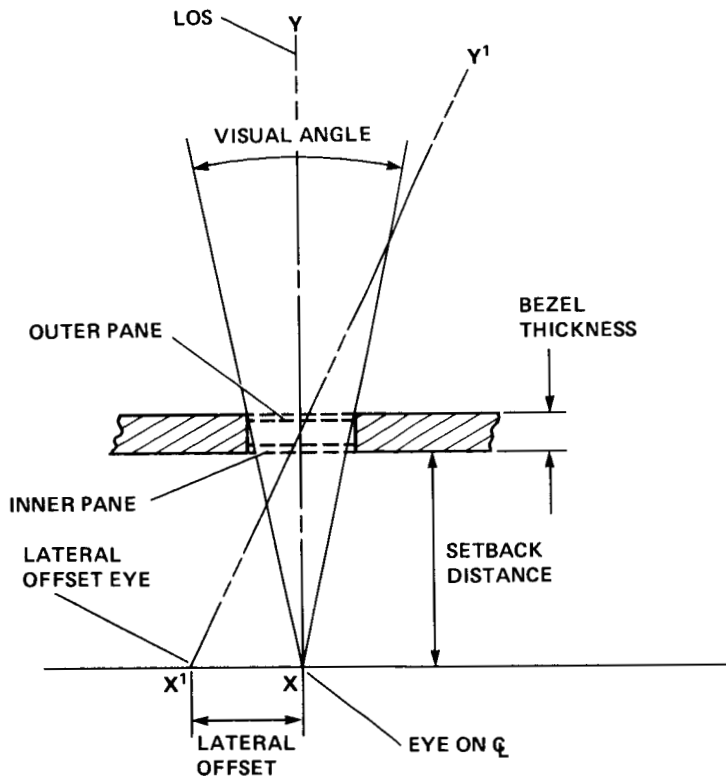

Figure 21.— On- and off-centerline geometry and related parameters determining FOV width.

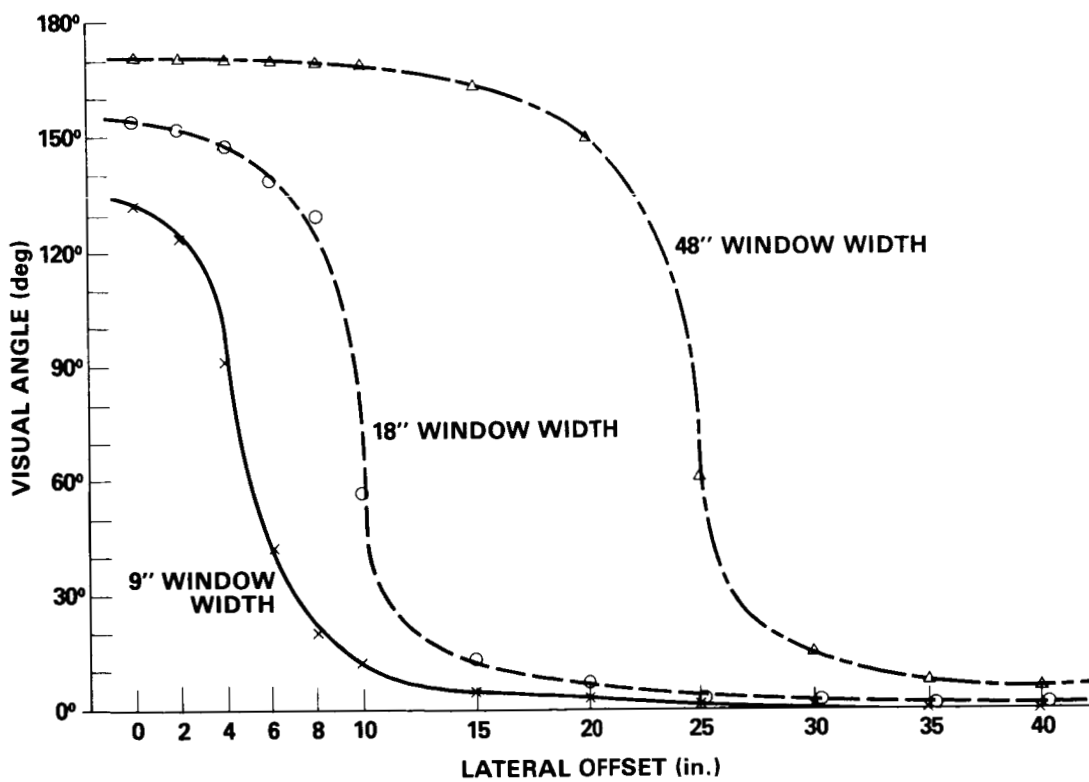

Figure 22.— Visual angles for three window sizes as a function of lateral offset at 2-in. (5.1 cm) setback.

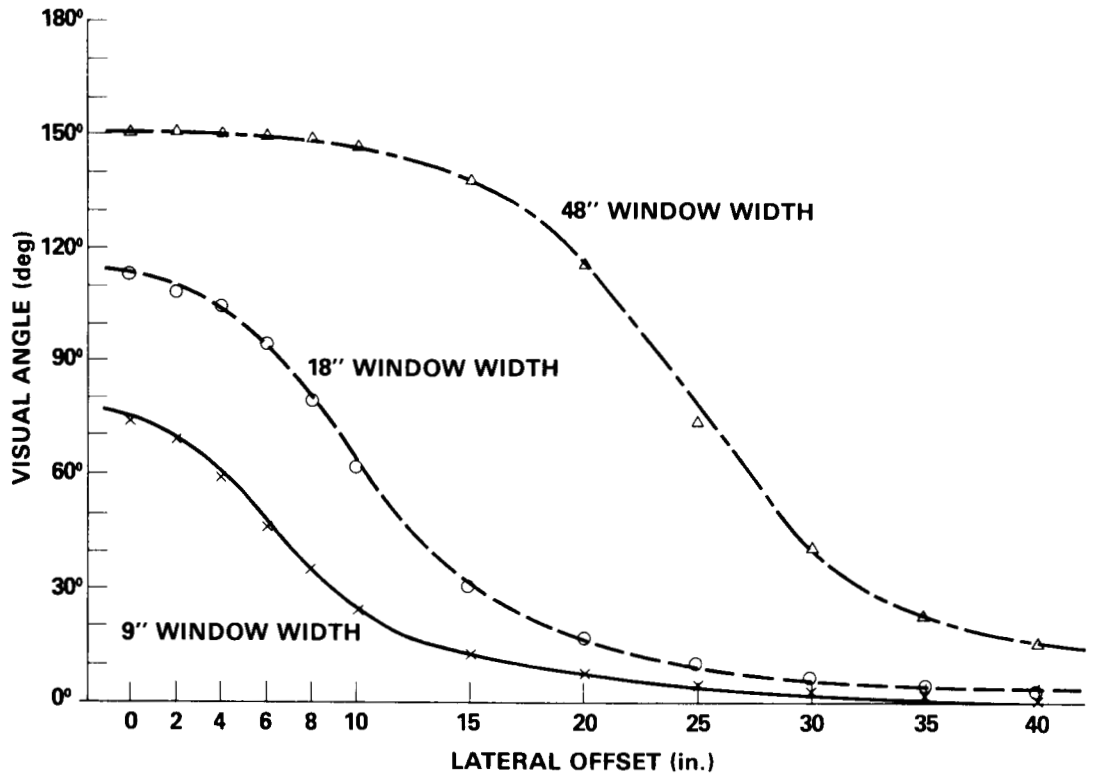

Figure 23.— Visual angles for three window sizes as a function of lateral offset at 6-in. (15.2-cm) setback.

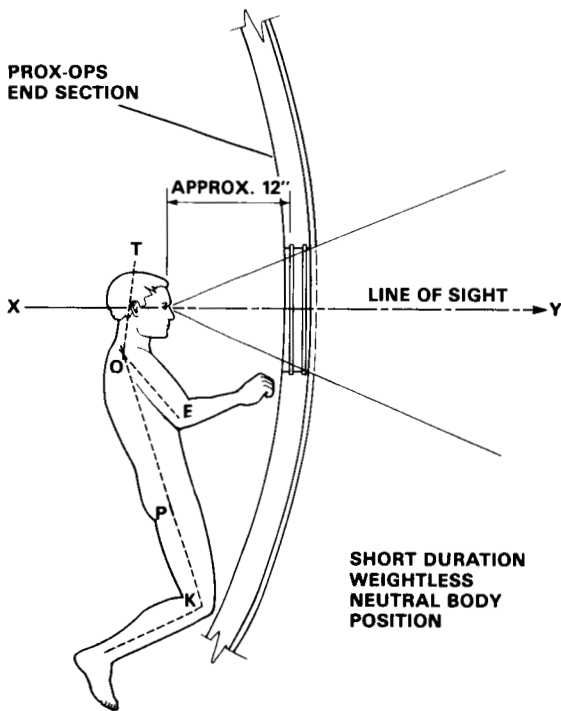

Figure 24.— Approximate body position for relatively small setback distances.

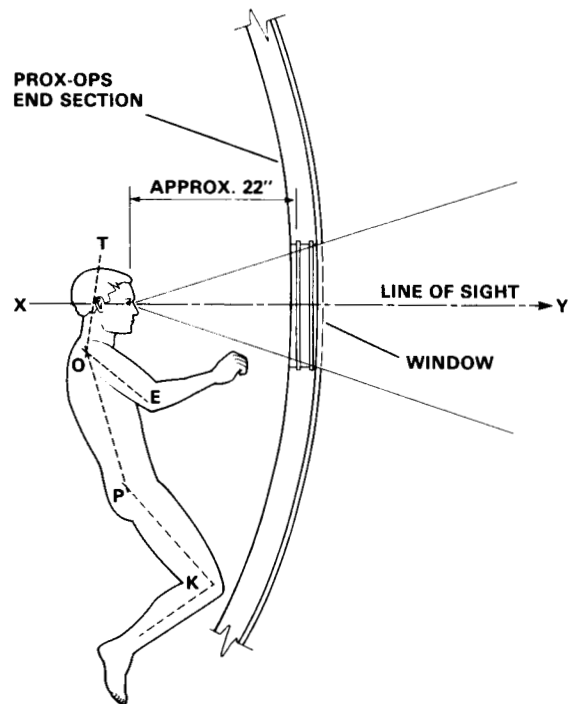

Figure 25.— Approximate body position for larger setback distances.

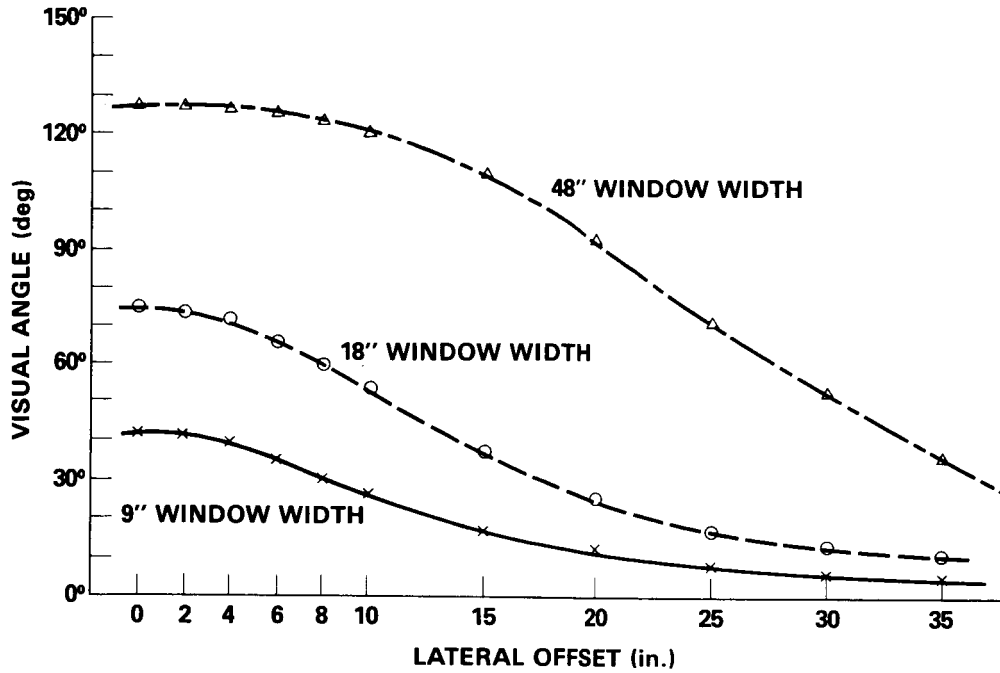

Figure 26.— Visual angles for three window sizes as a function of lateral offset at 12-in. (30-cm) setback.

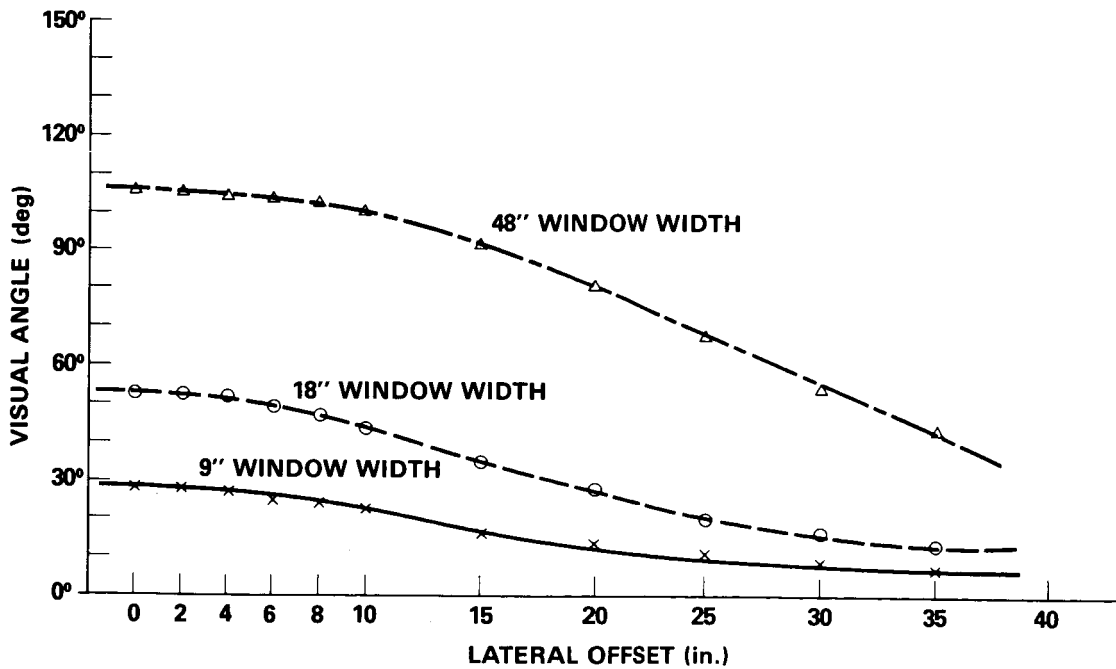

Figure 27.— Visual angles for three window sizes as a function of lateral offset at 18-in. (46-cm) setback.

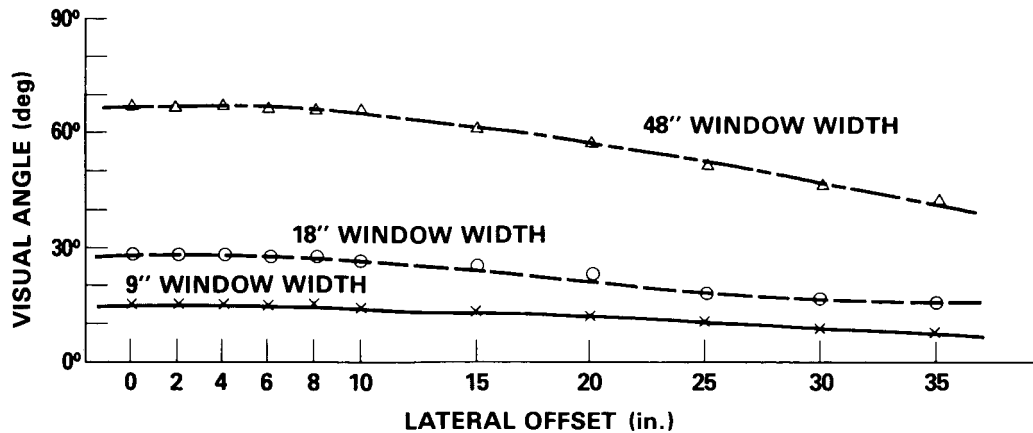

Figure 28.— Visual angles for three window sizes as a function of lateral offset at 36-in. (91-cm) setback.

4.4.4 Allowable Head/Eye Movements

Voluntary or involuntary head/eye movements relative to a given PROX-OPS window will affect a number of things, including

1. Total available external FOV
2. Apparent motion of an immobile external target relative to the window's frame (with possible distortions of motion judgments)
3. Apparent position within the window outline of an external target. If the perceived relative motion is ascribed to the external target and not to the head, serious consequences can result
4. Possible personal disorientation under some dark cockpit conditions which provide minimal spatial orientation cues

Because of these considerations it is recommended that viewers maintain their heads in relatively fixed positions behind a window during critical return/berthing and separation maneuvers when relative motion judgments are being made.

The size and placement of PROX-OPS windows relative to head-down displays and controls will affect the amount of head movement that is made. The analogy to the modern-day airplane cockpit is relevant here. MIL-STD 1472-C (1981) specifies that aircraft windows shall be located no more than $\pm 15^\circ$ (vertically and horizontally) from the normal LOS in a restrained (body) position. Section 4.4.4.3 discusses this issue in greater detail. Until further in-flight experience is gained on the matter of how much head rotation is too much, the following design guideline is offered.

The angle between the LOS from the DEP through the center of the PROX-OPS window to the central head-down displays should be as small as possible. Angles larger than 35° shall require detailed justification.

Among the kinds of head movements that are important to consider with respect to window design are (1) setback distance variation (radially from nearest windowpane); (2) vertical translation; (3) horizontal angular rotation of the head/eyes; and (4) vertical angular rotation of the head/eyes. These subjects are discussed next.

4.4.4.1 Radial (Setback) Translation

Using the geometric parameters shown in figure 21 for a single window, trigonometric calculations were made of the visual angle (degree) across the window as a function of setback distance. Also included as a variable was bezel thickness. These results are presented in figures 29–31 for a 12-in. wide (30.5 cm) window and three lateral offset positions (on window centerline), 6 in. (15.2 cm) and 12 in. (30.5 cm), respectively.

It can be noted from figures 29–31 that for a 12-in. (30.5-cm) wide window the external FOV angle decreases as the setback distance increases; however, the rate of change varies with bezel thickness and lateral offset position of the eyes relative to the centerline of the window. The external FOV angle increases with decreasing bezel thickness only for eye positions relatively near the centerline of the window. For larger lateral offset positions, no such increase in FOV angle is found for decreasing bezel thicknesses. When the eye is located well beyond the edge of the window (see fig. 31), the largest effective FOV angle is found moving radially back from the window at least 12 in. (30.5 cm).

Two operational guidelines, based upon the above data, are that the viewer should always try to keep his or her eyes (1) approximately centered within the window's edges and (2) as close to the nearest pane as possible.

These figures can be used to establish DEPs for a particular window configuration once the bezel thickness and window width is established. For example, if one wants to attain a visual angle of 100° through a 12-in.-wide (30.5-cm) window having a 2-in.-wide (5-cm) bezel, then at zero offset (fig. 29) the data surface is penetrated by the desired reference line at a setback distance of 6.5 in. (16.5 cm).

Research has shown that motion judgments are more accurate when the window's frame is also visible within the viewer's FOV (Brown, 1927, 1931; Cartwright, 1938; Duncker, 1929; Haines, 1984; Legge and

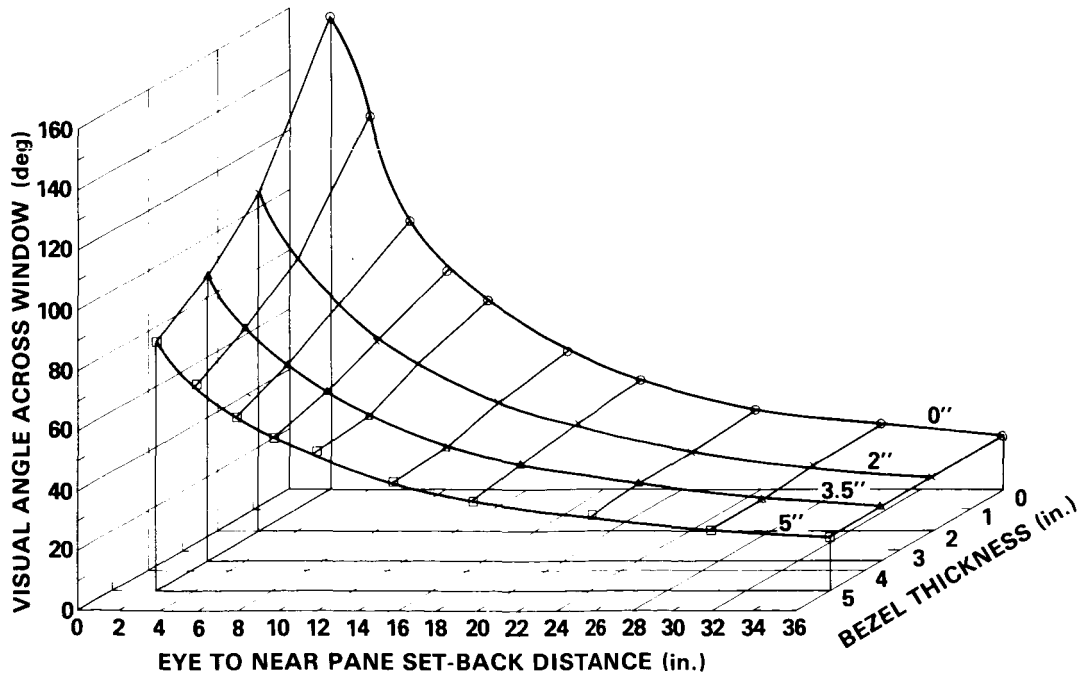

Figure 29.— Visual angle as a function of setback distance and bezel thickness for 0 offset eye position and 12-in.-wide (30-cm) window.

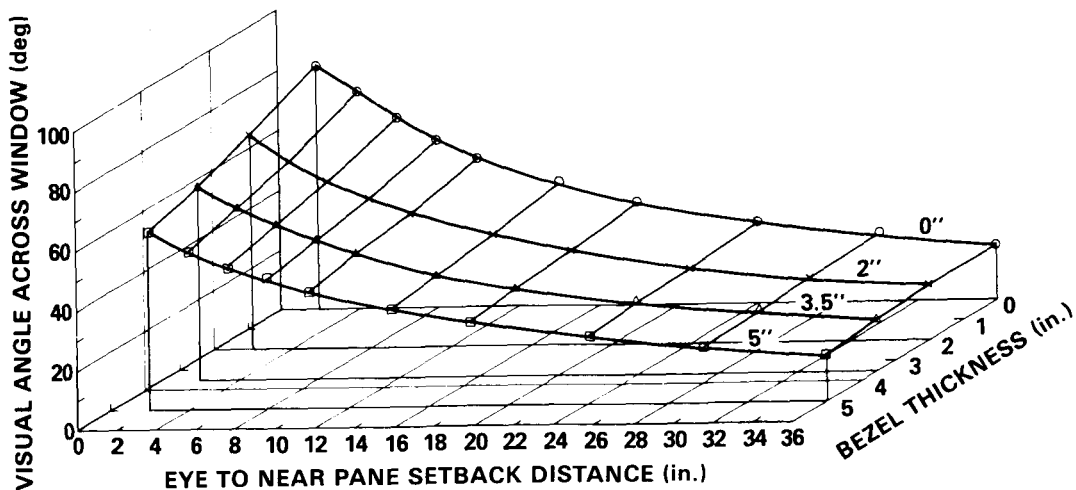

Figure 30.— Visual angle as a function of setback distance and bezel thickness for 6-in. (15-cm) offset eye position and 12-in.-wide (30-cm) window.

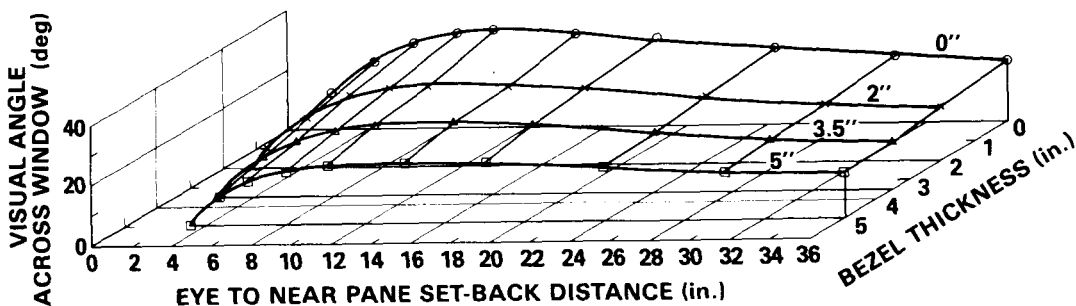

Figure 31.— Visual angle as a function of setback distance and bezel thickness for a 12-in. (30-cm) offset eye position and 12-in.-wide (30-cm) window.

Campbell, 1981). Since this is so, the above setback distances should be increased by from 2 to 4 in. (5 to 10 cm) to make the window frame visible. The small decrease in visual angle will more than likely be made up for in improved visual performance.

Figure 32 is a photograph taken from the Shuttle's aft bulkhead window with the entire window frame visible. Movement of a distant object (e.g., in the cargo bay or beyond) is judged with respect to its relative motion with the tail region of the Shuttle and, to a lesser extent, to the surrounding window frame. In addition, apparent motion of this frame provides immediate cues to head movement.

4.4.4.2 Vertical Translation

The previous figures related to lateral offset distance of the eyes (figs. 22, 23, 26, and 27) apply as well to vertical translation and may be used directly. The primary issue becomes the orientation of a nonsymmetrical window, such as a rectangle, relative to the viewer's range of body-axis orientations during viewing through the window. This subject will be discussed in section 4.5.

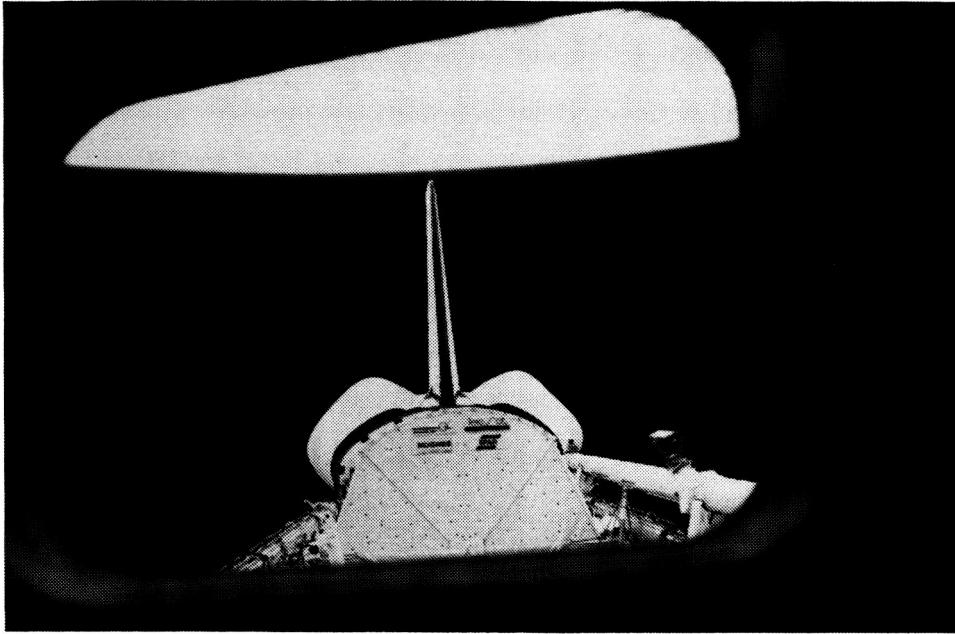

Figure 32.— Shuttle cargo bay from aft bulkhead window illustrating the effect of having the stable window frame visible (flight 51-A).

4.4.4.3 Horizontal and Vertical Eyeball Rotation Limits

With the head fixed in space, both eyeballs rotate within their bony sockets to a remarkably large extent. When the eyes have rotated more than about 35° horizontally or 25° vertically from their mean straight-ahead position (and a moving target requires even further eyeball rotation), the head will usually begin to rotate. Research has found that with the head rigidly fixed, one can rotate the eyes about 74° right, 55° left, 48° up, and 66° down from straight ahead. A plot of the corresponding monocular (right eye) FOV for these extreme eyeball rotations is given in figure 33.

How can such data be applied to the design of PROX-OPS windows? In the case of multiple, adjacent windows, one human factors question of interest is the degree to which a given window shape and area conform to the viewer's own FOV. This can be determined by reference to the centrally located, solidly outlined boundary in figure 33. If a dual-window design is being considered which requires a 4° -wide gap between the windows, then their polar coordinate projection laid over the polar coordinate projection of this figure (drawn to the same scale) will indicate the degree to which the viewer will be able to view out of each window merely by rotating his or her eyes. In short, head translation may not be necessary to optimize the FOV for each adjacent window.

4.4.5 Gap-Width Considerations

The size of the structural members between two windows is (here) called the "gap" and is an important design feature from a human factors point of view. Figure 34 illustrates the geometry of a single viewer viewing out of two adjacent windows. The Appendix contains selected cross-sectional drawings of previous NASA spacecraft window frames and points out the difficulty that will be encountered in trying to keep the window frame between adjacent PROX-OPS windows as small as possible.

It is apparent from figure 34 that the lateral visual angle of each window will be determined by the set-back distance, window width, lateral offset distance of the eyes from the centerline of the main window, and

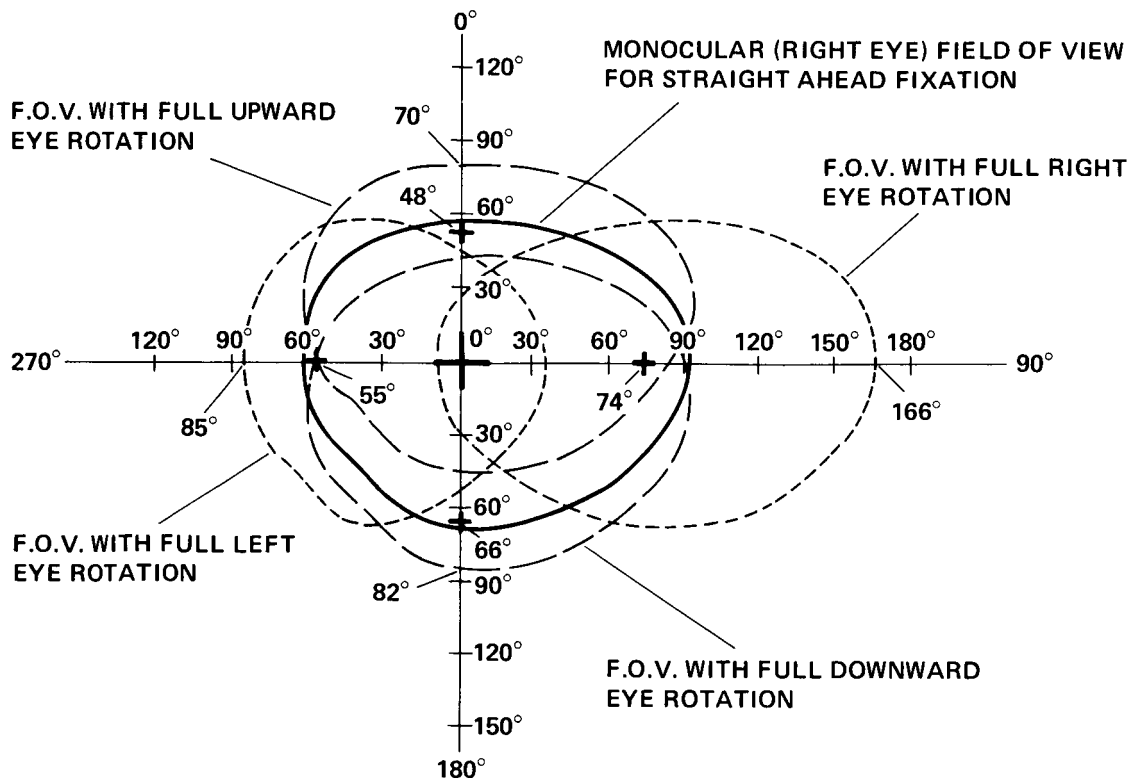

Figure 33.— Monocular (right eye) FOV plots for four extreme axial rotations of the eye.

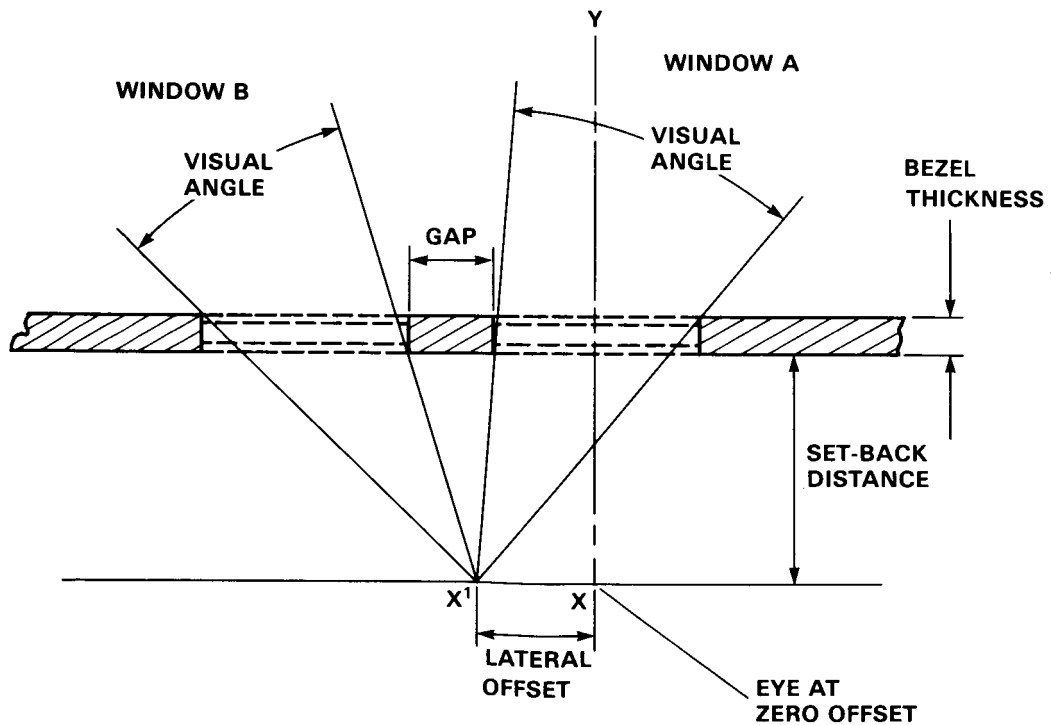

Figure 34.— Double-window geometry.

bezel thickness. The region of vision occlusion will be determined by the setback distance, gap width, and lateral offset. Since the average interocular spacing is 2.5 in. (6 cm), any gap larger than 2.5 in. (6 cm) will produce some physical occlusion to binocular vision. Gaps smaller than 2.5 in. (6 cm) will occlude monocular vision since what one eye can't see because of gap occlusion the opposite eye can see because of its lateral separation. Of course this applies only for gaps oriented approximately vertically. This situation is illustrated in figure 35.

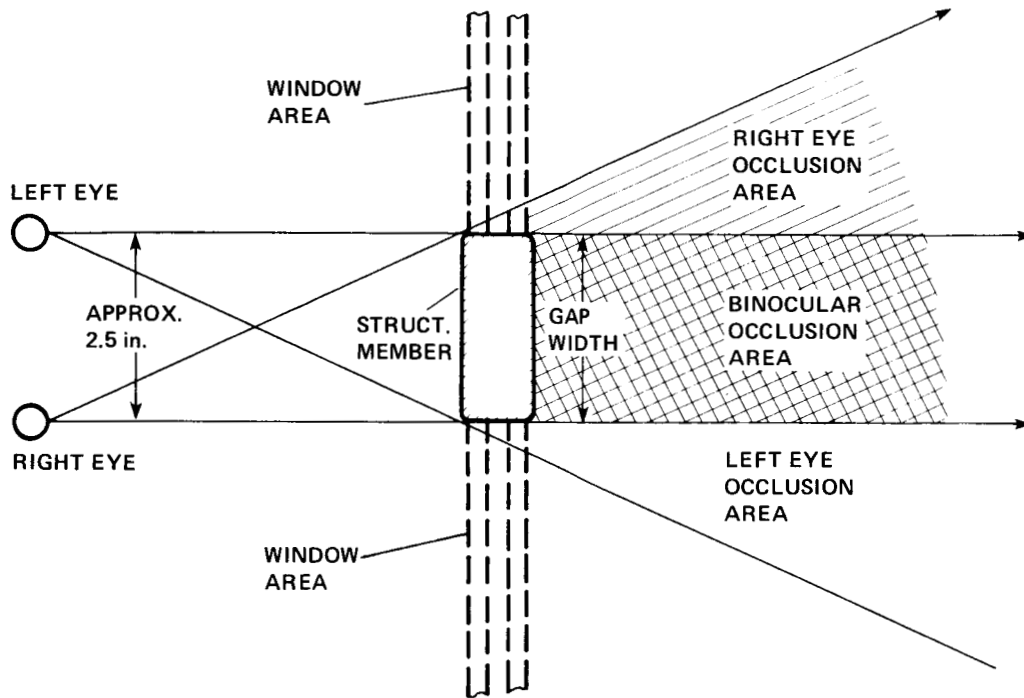

Figure 35.— Visual occlusion due to window gap width.

Gaps between adjacent windows should be as narrow as possible.

Trigonometric calculations have been made of the visual angle for each of two 12-in.-wide (30.5-cm) windows separated by a 5-in.-wide (13-cm) gap with the eyes located 2 in. (5 cm) back from the nearest pane. The variables calculated included lateral offset of the eyes from the center of one window (inches; plotted on the abscissa) and bezel thickness (inches). The results are presented in figure 36.

It can be noted from figure 36 that a significant change in visual angle is produced merely by moving the eyes laterally (parallel to the windowpane); these angles range from a maximum of 83° on the centerline to 0° at 10.5 in. (26.7 cm) laterally from the window's center. At this point the eye will begin to be able to see out of the other window. Decreasing bezel thickness at eye locations near the window's center yields a faster increase in visual angle than decreasing bezel thickness at eye locations near the window's edge. Gap width merely determines the amount of separation or overlap of the two contours.

While the above discussion applies to a single viewer for two adjacent windows, there is also the possibility of there being one viewer per window. This is illustrated in figure 37, with the right-hand window viewer approximately centered and the left-hand window viewer shown in each of two possible head positions. The right-most head position places both viewers in a shoulder-to-shoulder position. Since the adult male 95th

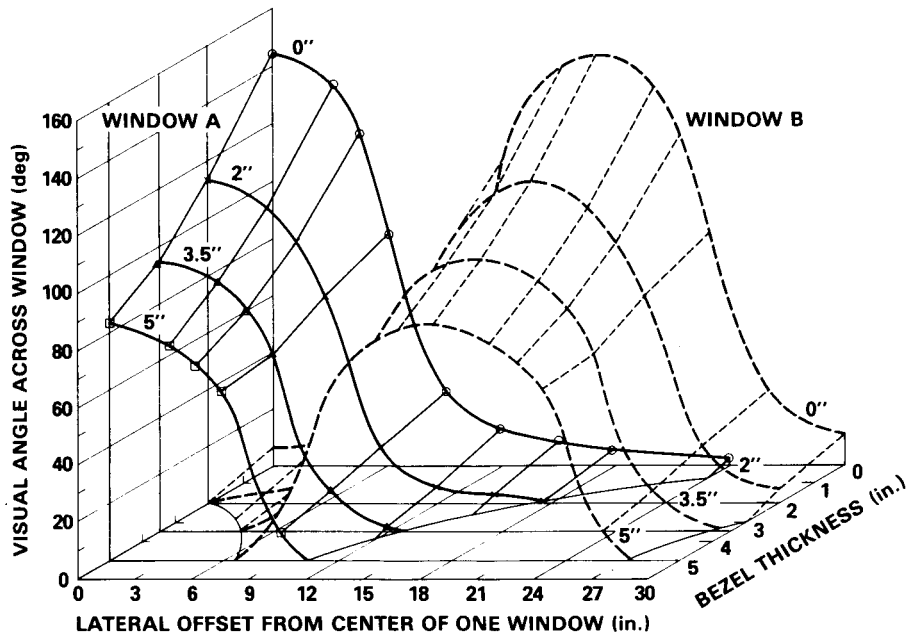

Figure 36.— Visual angles subtended by each of two 12-in.-wide (30-cm) windows separated by a 5-in.-wide (13 cm) gap as a function of lateral eye offset and bezel thickness.

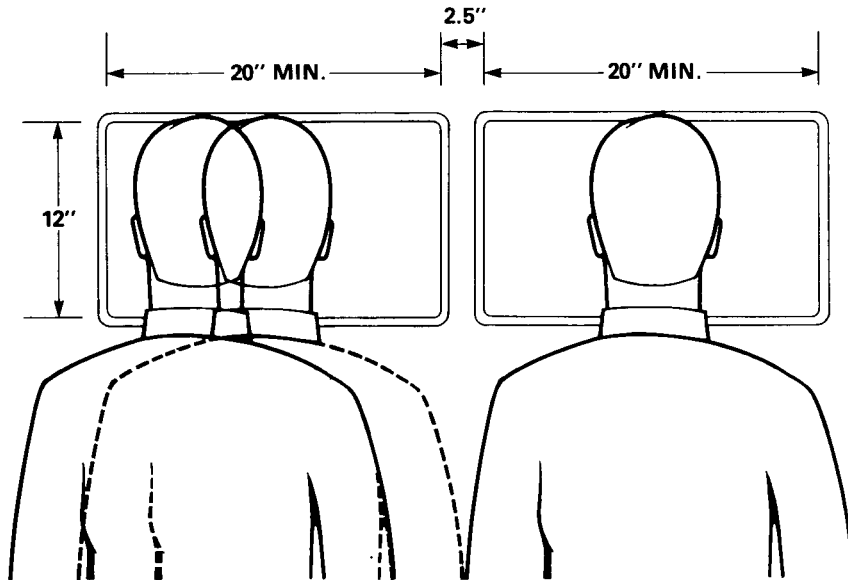

Figure 37.— Two viewers using adjacent windows.

percentile shoulder width is 19.6 in. (50 cm) (17.6 in. (45 cm) for females), the centerlines for the two heads will be about 20 in. (51 cm) apart.

The windows should, if possible, be larger than 20 in. (51 cm) to allow maximum FOV for each viewer.

A gap width of, say, 5 in. (13 cm) will permit even greater separation between adjacent viewers.

4.5 Distribution of Various Sensitivities in the Visual Field

The observer at the PROX-OPS windows brings with him or her an array of visual capabilities such as motion sensitivity, acuity, color perception, reaction time, contrast sensitivity, motion sensitivity, etc. It can be shown that each of these capabilities is spatially distributed in different ways within the full, binocular FOV, which is illustrated in figure 38. This figure is interpreted as follows. With the eyes open, head vertically erect, and the LOS upon the center of the diagram at the spot labeled the fovea, the irregularly shaped closed boundary represents the angular size and shape of the monocular right-eye plot (left diagram) and the binocular FOV (right diagram). Thus, one can see a small light source located about 58° above and 75° below the LOS, etc.

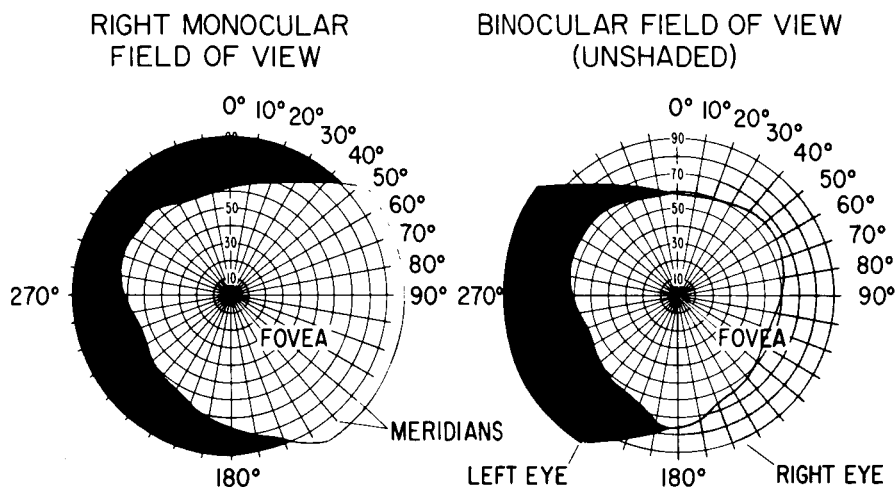

Figure 38.— Binocular and monocular angular FOV.

As has been discussed elsewhere (Haines, 1975), the placement of controls and cockpit displays may be optimized by taking into account certain distributions of visual sensitivity. Several such distributions are presented below in support of window angular-width-design guidelines for the PROX-OPS windows.

Motion sensitivity of object size change. The PROX-OPS flight procedures handbook (Ober, 1982) specifies that "...for ranges (from the viewer to target vehicle) <200 feet the crew must also have some type of visual contact out to a range of 1000 feet." For the Shuttle, which is 37 m (121 ft) long viewed from the side, it will subtend the visual angles at the separation ranges given in table 9. Nominal or "target" range rates are also given in Ober (1982, pp. 2-3).

For a 12 in. (30.5 cm) setback distance and a 48-in.-wide (122 cm) window, the maximum window visual angle will be 128° (see section 4.4.3 (fig. 26)). Thus, under these particular conditions one or both ends of the Shuttle vehicle will disappear from view when it is closer than about 30 ft (9 m). When the entire window is filled with the approaching target vehicle, the eye will require additional range and range-rate cues with which to judge the progress of the maneuver. Visual details having fixed, known dimensions (e.g., painted American flag, black grid lines spaced 5 ft (1.5 m) apart on a white background, surface texture made by rivet heads) will provide valuable range and range-rate cues by themselves. And when the viewer is positioned to keep the window frame in the FOV during these judgments, accuracy will be maximum. This subject is treated in section 4.4.4.1.

It can be shown mathematically that maximum sensitivity to a change in visual velocity is found along a cone, centered on the LOS, with a half-angle of 45° arc. This is supported by laboratory data, as will be

TABLE 9.— TARGET OBJECT VISUAL ANGLES AS A
FUNCTION OF SEPARATION RANGE FROM THE
OBSERVER

Range, ft	Visual angle, deg	Range rate, ft/sec
1,000	6.92	1.0
750	9.22	
500	13.80	.5
400	17.20	.4
300	22.80	.3
200	33.66	.2 (station-keep)
100	62.35	
75	77.78	
50	100.86	
35 (grapple distance)	119.90	0.0
10	161.23	

pointed out. Thus, to support visual judgments of closure rate between the observer and an approaching Shuttle (see table 9), the most accurate closure rate judgments will occur at a distance between 75 ft (23 m) and 50 ft (15 m) to the Shuttle (seen in side view) when it subtends a total visual angle of about 90° arc. The research on which the above value is based deserves further explanation.

The PROX-OPS window(s) should provide a horizontal FOV of 90° arc as a minimum.

Lina and Assadourian (1963) determined the minimal visual threshold for detecting range rate as a function of range during a radial approach to a projected image. The stimulus (image) consisted of two parallel luminous lines which appeared to lengthen as well as to move farther apart over time as they might appear during a direct (normal) approach. The stimuli were projected onto a large screen whose edges were visible and (likely) provided valuable references for making this judgment. This early NASA study was conducted to find out whether an observer could control a lunar landing (given reasonable braking thrust and adequate fuel supply). Each of the two observers was permitted 2 sec to view an expanding or contracting pattern, which started at each of four initial separation angles (11°, 41°, 68°, and 128° arc). Each observer had to discriminate whether the pattern appeared to get bigger or smaller. The two observers differed in their motion sensitivity, with one having a minimal $\dot{h}/h = 0.013$ and the other having a minimal $\dot{h}/h = 0.016$. It was found that greatest approach and departure velocity sensitivity occurs for targets subtending from 40° to 80° arc as illustrated in figure 39 (adapted from Lina and Assadourian (1963), fig. 4). Research is under way in the author's laboratory to verify this finding using conditions which are more representative of orbital viewing conditions.

It can be pointed out that during PROX-OPS, range rate should decrease regularly with a decrease in target range until final contact occurs with the Space Station. These data show, however, that there will be a tendency to misjudge target approach velocity at those ranges at which the target subtends angles larger than about 90°, i.e., at the close separation distances just prior to contact when range and range rate should be perceived most accurately.

Auxiliary range and range-rate information should be provided to supplement visual judgments made through PROX-OPS windows. A computer-generated, virtual-image HUD superimposed over the window could provide such information.

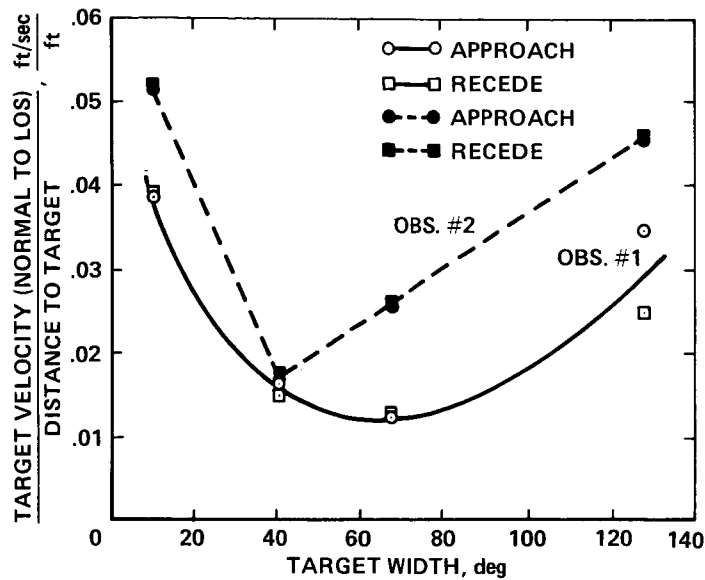

Figure 39.— Target approach and departure sensitivity of two observers as a function of target size.

Visual acuity is also known to vary significantly within the visual field (Freeman, 1966; Kerr, 1971; Low, 1946; to name a few laboratory studies). Acuity is best at the fovea (where the LOS intersects the retina) and becomes progressively worse with angular eccentricity. During PROX-OPS the need for high acuity should be limited to visual judgments of the identity of cargo, small free flyers, astronauts in MMUs at a distance, and other angularly small targets.

The windows must possess sufficient optical clarity to not significantly degrade visual-acuity judgments.

Color perception also varies with where in the visual field the colored source is located (Ferree and Rand, 1924). The size and shape of these “color zones” also vary with the size and intensity of the colored source presented. In general, the larger and brighter the source, the larger the visual area within which the viewer will correctly discriminate its color. These color zones are generally horizontally oriented ovals, centered on the LOS, with red and green sensitive receptors lying nearest the LOS (within a radius of about 15° arc) and blue and yellow sensitive receptors lying within a radius of about 30° arc. If a colored source is imaged beyond these color sensitive areas, it will possess brightness, but no distinguishable color. There are no clear-cut design implications for the windows related to this (spatial) aspect of color perception. The spectral transmission of the entire window area is important and is discussed in section 5.1.2.

Reaction time (RT) to the onset of a visual stimulus also varies with the location of the stimulus within the FOV. In general, fastest RT occurs at or near the LOS. Zones of equal RT have been found to be horizontally oriented ovals centered on the LOS (Haines and Gilliland, 1973; Haines et al., 1975). Since mean RT increases in a regular manner with an increase in the angle off the LOS, PROX-OPS window width is determined by the desired mean RT for a given task more than by the need for a wide FOV.

4.6 Number of Viewers per Window

One of the initial design assumptions given in section 1.3 was that there would be only one viewer per window. This subject deserves further discussion because of the far larger interior volume that is available at the PROX-OPS station and the possibility of larger windows than have been used heretofore. The modern

commercial airplane cockpit provides a rough analogy for window sizing and layout. In current two- and three-flightcrew commercial air transports, all flightcrew members can turn their heads and see out of all available windows even though their eyes may be situated only from 12–24 in. (30–61 cm) from the nearest windowpane. In Space Station, somewhat the same situation will be possible if there are properly designed multiple windows. This is illustrated in figure 40, which represents a PROX-OPS station concept with minimal head room due to an “own-feet down” layout concept. A window layout configuration similar to this one would permit multiple viewers in the PROX-OPS area as well as a wide FOV for each viewer to enhance overall situational awareness which is so critical. There are also other candidate designs which would do the same.

In figure 40 the dashed contour line represents the viewer’s approximate binocular FOV limit for a LOS through the center of the right-hand window. The dashed horizontal and vertical lines represent the horizontal and vertical (imaginary) local meridians. It can be seen that the binocular contour encompasses much of the interior control panel area located under the windows. If these controls and displays are properly designed by taking into account human factors layout principles (USAF Syscom Handbook, 1984; Haines, 1975; Van Cott and Kinkade, 1972), a greater degree of situational awareness can be maintained.

It is still possible for two viewers to use a common window (for a single window whose width is equivalent to the approximate shoulder width of a single viewer). There may be certain station-keeping operations which will require two crew members to observe a target vehicle simultaneously from the same window,

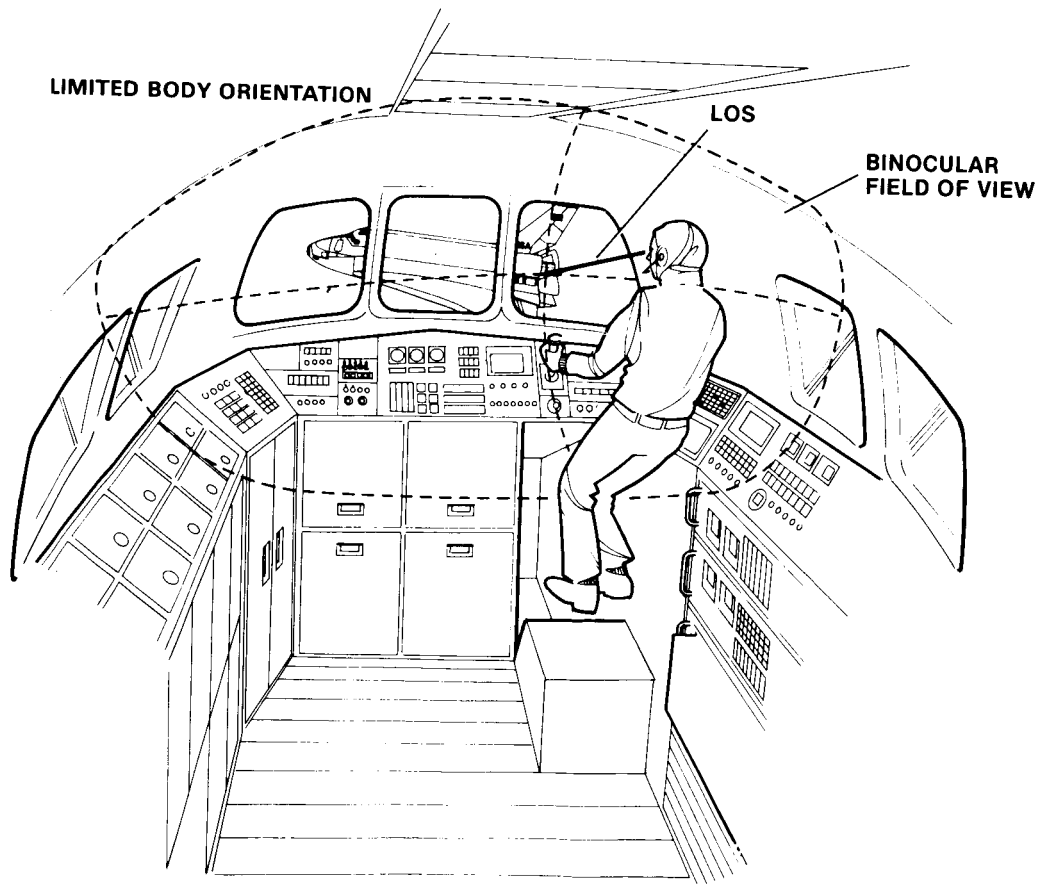

Figure 40.— PROX-OPS station with wraparound window layout.

much as a pilot and first officer perform a “monitored approach” to landing. Thus, one crew member maintains constant fixation upon the target while the other is free to cross-check the approach against various instrument references. Figure 41 illustrates an approach permitting two viewers to use a single window. A possible problem with this approach is subjective disorientation for those viewers who may prefer their own feet to represent the “down” direction.

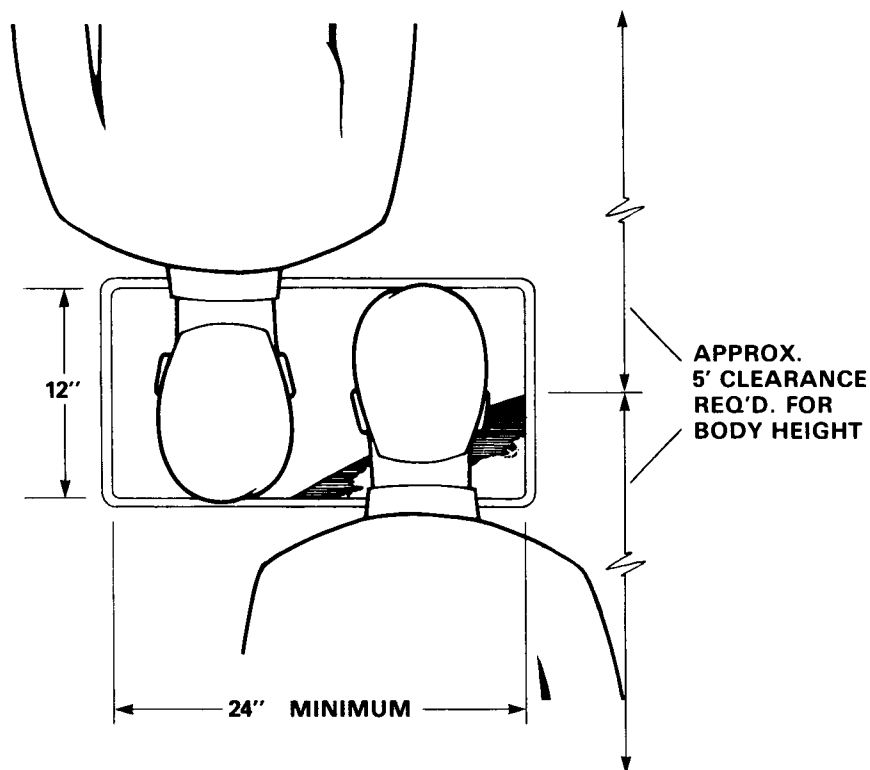

Figure 41.— An approach to permit two viewers per window.

4.7 Number of Windows and Location Relative to Viewers

The total number of windows will be determined by many different factors, which include at least the following parameters:

1. FOV requirements for all anticipated viewing tasks
2. Total number of viewers who will be involved in PROX-OPS monitoring/control using the windows
3. Structural design limitations
4. Weight penalties (glass vs. metal vs. other materials)
5. Window size and shape
6. Safety considerations related to window breakage probability
7. Economic considerations

Since the PROX-OPS station will (likely) possess integrated displays colocated with the windows to permit sequential cross-comparisons of the various PROX-OPS and extravehicular activity (EVA), specification of the number of windows must also consider internal layout requirements for controls and displays. Considering the importance of providing for total situational awareness during PROX-OPS, each viewer should have

access either to an individual window having a sufficiently wide FOV or an array of separate windows with an overall FOV that is equally as wide.

At one end of the spectrum of windows is a completely transparent hemisphere which literally fills the end of a module (fig. 42) and which could incorporate computer-generated symbology in the plane of the glass. Present technology cannot achieve such a window. However, the concept does illustrate the degree of situational awareness that could (theoretically) be achieved someday when the technology becomes available.

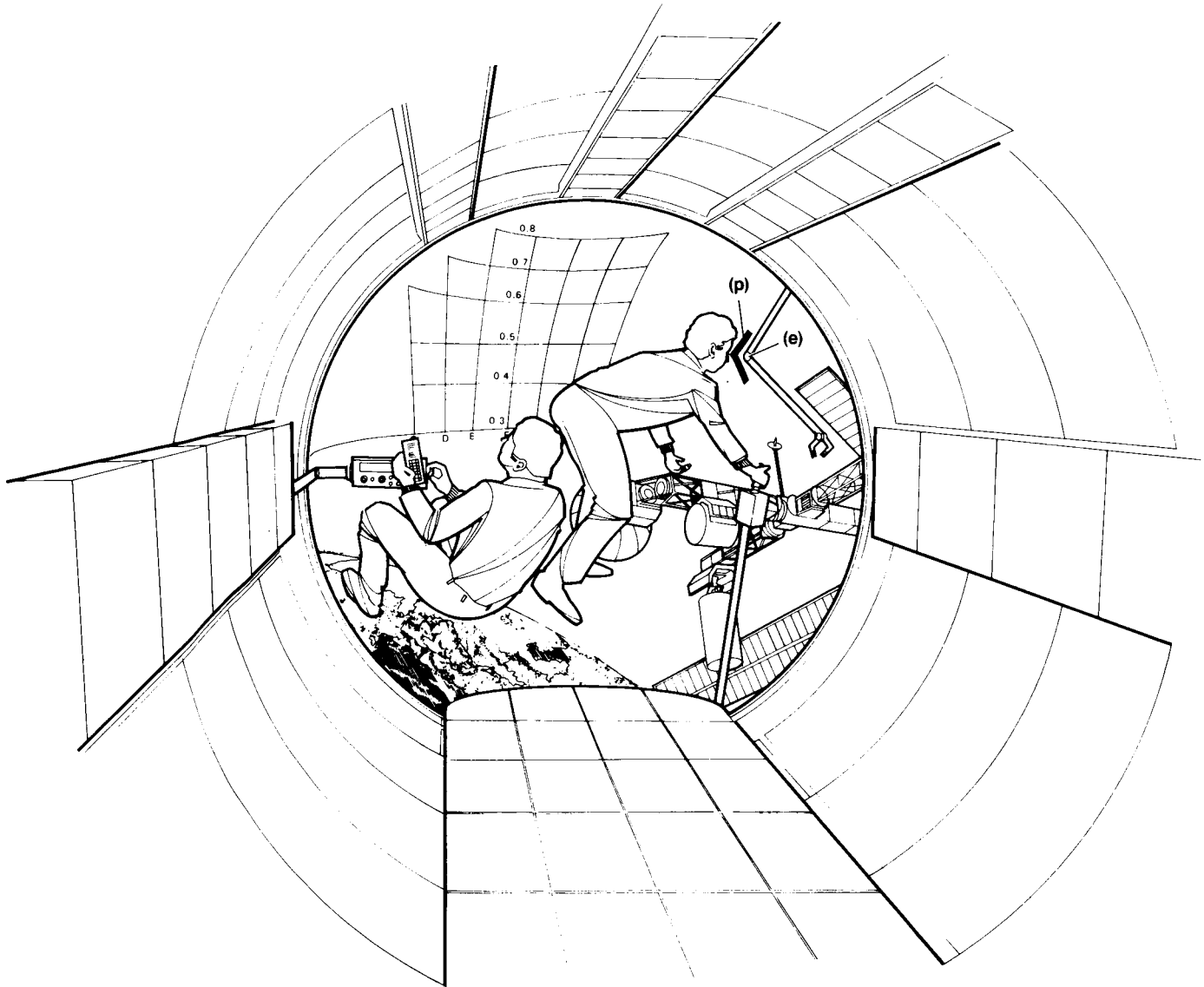

Figure 42.— Futuristic PROX-OPS viewport incorporating yet-to-be-developed pixel-addressable HUD capability.

4.8 PROX-OPS Station Controls and Displays Relative to the Windows

Window layout and design cannot be divorced from the location and design of other displays and controls which will be used during PROX-OPS. Current human factors layout and design concepts can be used to help ensure optimal information transfer to the observer (Woodson (1981) and Griffin (1978)). Of rele-

**ORIGINAL PAGE IS
OF POOR QUALITY**

vance here is the fact that the PROX-OPS station displays should be designed in such a way as to take into account the inherent light-detecting capability of the observer's peripheral visual field for a variety of viewing directions. As is illustrated in figure 43, for example, as the observer looks down at the display panel from the window, different regions of the PROX-OPS display panel will be visible in comparison with the LOS shown in figure 40. The upper region of the visual field also will be able to perceive motion of a vehicle outside the windows.

In general, the angle between the LOS through the window and the location on the instrument panel that is looked at with the greatest frequency should be no more than 30° arc vertically and 40° arc horizontally.

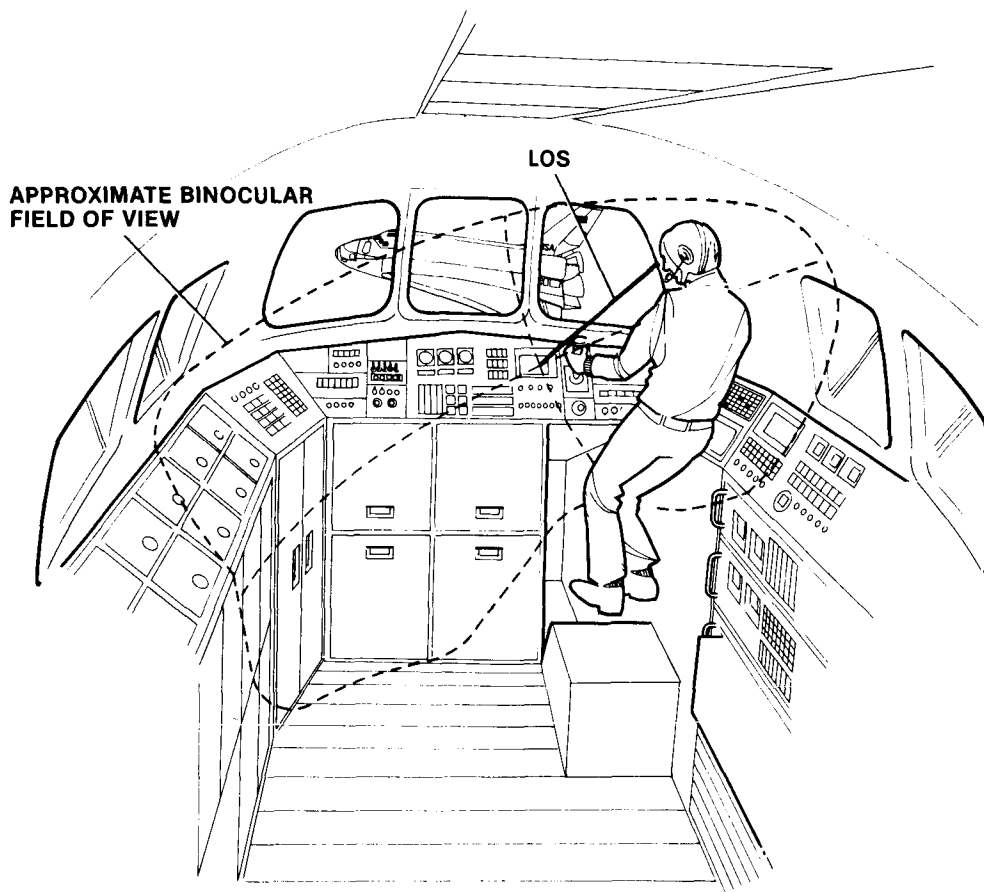

Figure 43.— Binocular FOV for an inclined LOS.

5. WINDOW OPTICAL REQUIREMENTS

While it is not the intent of this paper to discuss in detail the optical properties of glass or related physical aspects of how the panes are clamped or installed, it is necessary to provide some comments in these areas where they affect the ability of an observer to make effective visual judgments through them or where the crew must maintain their optical qualities or replace them on-orbit.

Glass is a supercooled, noncrystalline liquid which is elastic and isotropic (Pigg and Weiss, 1973). There are two basic kinds of glass used in windows:

1. Annealed glass: This process of alternatively heating and cooling glass is also known as "heat-treating" and influences the grain structure. It is done to achieve harder glass, among other things. Annealed glass exhibits so-called "static fatigue," which is a degradation of allowable stress as a function of time at load. Known as "stress corrosion," static fatigue is actually flaw growth caused by combined physical stress and other environmental conditions (water, moisture).

2. Tempered glass: Here the manufacturing process compresses the surface to eliminate surface tension stresses. Thermal tempering results in a residual (parabolic) distribution of stress throughout the thickness of the glass. There is also a compressive stress on the external surface that is approximately twice that of the tensile stress at the middle of the glass.

From a human factors standpoint, the key issue here is whether or not humans can and/or should take part in window integrity monitoring over time. During very early stages of stress corrosion where a flaw is microscopic (i.e., well under the resolution limit of the unaided eye), a time-consuming process of magnified inspection of each square centimeter of window area would be required to detect the flaw(s).

An automated, early-warning, flaw-detection technique is needed for Space Station windows to unburden the crew of this vitally important, but tedious, procedure.

5.1 Transmissivity

Window transmissivity should represent the best overall compromise between providing eye protection from solar (and other) radiation in space and visibility requirements for detecting, recognizing, and manually controlling small, dim targets.

Clearly, the ability to see through PROX-OPS windows is critically important. Following is a brief excerpt from the Skylab Mission Report (NASA TM X-64814, 1974) on the Saturn Workshop (pp. 11-22) to illustrate the many sources of transmissivity change.

The wardroom window was used extensively for general viewing, photography, and television and therefore was under continuous scrutiny. When the window was first activated, a small ice formation about the size of a dime was noticed in the center of the inner surface of the outer pane. A more critical inspection later revealed an oily film on the outer surface of the outer pane. The film appeared to have water streaks which ran toward the aft end of the vehicle. It is suspected that both of these effects resulted from conditions existing on the pad before launch.

As the mission progressed the ice spot alternately melted and refroze as the window heater was turned on and off and also as the effects of Earth albedo increased and decreased. It eventually spread to nearly 4 inches in diameter. The volume between the panes was vented to space through the scientific airlock vacuum vent and then repressurized with dry air....The evacuation and repressurization process was required approximately every 2 weeks during the second manned period and every 3 weeks thereafter, but the spot and internal streaking never completely disappeared. Even immediately after the repressurization with dry air some solid residue remained.

The experience with Skylab wardroom windows should not be repeated with Space Station PROX-OPS, or any other of its window(s). The important topic of window maintenance is raised briefly in section 6.2.

Window transmissivity is the proportion of luminous flux which passes completely through a window to the eyes (or sensor) to the amount of luminous flux incident upon the outside of the window. Transmissivity is a critically important design parameter for several reasons, which are discussed briefly. First, one of the visual tasks that the PROX-OPS windows must support is the visual localization (relative to the Space Station) of very small, faint sources of light such as a specific star, a light source on a target vehicle, or a light source on the Earth's surface. The lower the transmissivity, the more intense the light source must be to be just perceptible. The interested reader should consult Haines (1968), Haines and Gilliland (1973), Heinisch and Schmidt (1970), Hyman (1963), and Zink (1963).

The optical transmissivity should be constant and as high as possible over the entire surface area of the PROX-OPS windows.

The optical transmissivity should not vary by more than 25% for angles between the window surface and LOS ranging from 0° to 70° arc.

Why should window transmissivity be constant over its entire surface area?

1. Visual detection range of very faint light will be independent of where they may first appear in the window. That is, the visual detection lobe will be determined only by the viewer's visual capabilities and limitations rather than by the optical properties of the intervening window(s).
2. Visual judgments of target surface contrast involved in judging attitude and attitude changes will remain constant as the target is seen to move across the window.
3. Visual comparisons of the size of two identical, small light sources will be very nearly identical. If one were much more intense than the other (because of differential window transmissivity), it would appear larger and closer (Haines, 1967; Haines and Bartley, 1966).
4. Visual judgments of target motion will be affected by (apparent movement) distortions that are produced when a restricted part of the retina is stimulated by a reasonably bright target (Bartley, 1958, pp. 264-265).

The following guideline is adapted from a Skylab 8190A window specification. It should be considered tentative until further developmental work has been conducted on current optical coatings which will not degrade significantly over prolonged exposure to solar (and other cosmic) radiation (see STR-ER-0003, 1977).

The installed PROX-OPS window assembly shall possess a transmissivity of no less than 70% across the major portion of the visible spectrum (400-680 nm) and no less than 35% across the range 680-800 nm.

The maximum transmission of ultraviolet radiation (200-400 nm) shall be no greater than 0.001%.

Another consideration with regard to transmissivity is that of the overall optical quality or homogeneity of the glass. Tiny particles of foreign matter or air bubbles are known as inclusions. Even though very small inclusions will be invisible to the eye, they can still produce light scatter which can degrade visibility through the glass. A high density of visible inclusions can "capture visual accommodation" so that during certain viewing conditions the viewer may tend to focus much nearer than otherwise.

For "seeds" or air bubbles having a maximal dimension of 10 μm or larger, their total area shall not exceed 0.1 $\text{mm}^2/100 \text{ cm}^3$ of glass.

A further general consideration related to window transmissivity is that of surface quality. The specification used for the Skylab 8190A window (Space Transportation System User Handbook, 1977) is repeated here.

The PROX-OPS window surface quality shall be 60/40, or better, as defined in MIL-0-13830 (2) (1982).

5.1.1 Absolute Transmissivity (Visible Spectrum, Near-IR, Near-UV)

The full visual spectrum from 400 to at least 800 nm should be admitted through the PROX-OPS windows to support the widest range of human visual performance.

As figure 44 shows (adapted from Griffin et al., 1947), the relative spectral sensitivity of the dark-adapted fovea and peripheral retina to a 1° arc-diam test object exposed for 1 sec extends well into the near IR (beyond 900 nm) given sufficient energy. As Bartley (1962, p. 935) points out, at the visual threshold of the dark-adapted eye, IR radiation is seen only with the peripheral retina and is achromatic (colorless). These data are presented because many human factors handbooks lead readers to believe that humans can perceive only wavelengths up to about 730 nm.

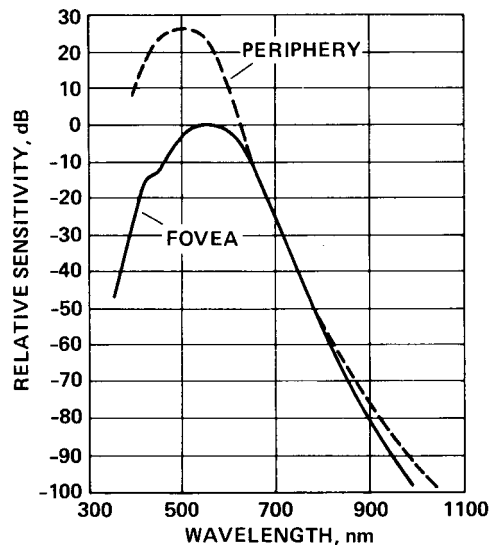

Figure 44.— Relative spectral sensitivity of the dark-adapted fovea and periphery.

It is seen in figure 44 that both the fovea (cone receptors sensitive to color) and the periphery (mixed rods and cones having greater sensitivity to luminous energy) possess very nearly the same maximum sensitivity peak at about 500–540 nm. The reader should consult Alpern et al. (1965), and their references as well, on this topic. Such data should be used to guide the selection of spectral coatings on these windows.

Prior U.S. Spacecraft Specifications. The percent transmission in the visible spectrum for the spacecraft windows on American spacecraft has always been an important design parameter. Since the early Mercury capsule days, continual progress has been made to improve the total transmissivity of the windows in the visual spectrum under on-orbit conditions which are known to degrade transmissivity because of the abrasion

of micrometeorite dust, pitting of larger particles, and coloration resulting from cosmic and solar radiation. It is reasonable to say that all prior manned spacecraft have been designed with the knowledge that the spacecraft will be returning to Earth so that the windows can be cleaned and/or replaced. This is particularly true for the Shuttle vehicle. However, the Space Station will impose a new design constraint in this regard since all problems with the windows will have to be dealt with on-orbit. Sections 6.2 and 6.3 deal, in general, with these important subjects from the human factors point of view.

Following are selected details concerning prior U.S. Spacecraft window transmission specifications; related information is given in the Appendix.

According to North American Aviation MA 0201-0415 (1965), the Apollo windows possessed (1) a single layer of MgF_2 antireflectance coating, (2) a multilayer blue-red reflection coating, and (3) a high-efficiency reflection reducing (HEA) coating. Coating (1) was used on the outermost windowpane on the Apollo Command Module window, (2) was used on the innermost surface of the outer window, and (3) was used on both surfaces of the two inner panes. According to these specifications, all coatings were designed for use at an incidence of 45° to normal.

5.1.2 Spectral Transmissivity (Selected Wavelengths)

There may well be some circumstances which require differential transmission as a function of wavelength(s). Protection against laser beam penetration may be one of these. If such a situation is anticipated, a specially designed add-on filter pane could be provided. In general, however, spectral filters should not be employed on PROX-OPS windows.

5.1.2.1 Dichroic/Trichroic Filters for Heat Rejection/Control

If thermal balance studies show that IR radiation must be kept out of the PROX-OPS station, special (dichroic and/or other) coatings may be applied to the windows. Because of the variation in surface color of such coatings as a function of viewing angle through the window (relative to a line normal to the surface), dichroic and trichroic heat-rejection coatings are not recommended. These variations in color derive from white illumination reflected from the viewer's side of the surface into the eyes. The spectral transmission through the surface is not necessarily influenced as a function of viewing angle.

While such color variations are not likely to influence visual judgments of range and range rate of a target vehicle, it is possible that judgments that involve aspects of color contrast or target size (e.g., judging the apparent distance to a target which has colored checkerboard patterns) might be adversely influenced.

Until further heat-load studies can be carried out, the following tentative IR transmission guideline is offered.

The maximum transmission of IR radiation (800-1500 nm) shall be no greater than 10%.
--

5.1.2.2 Monochromatic Filters for Visual Contrast Optimization and Scientific Tasks

Specially designed monochromatic filters needed to support specific observation and experiments may be provided for one or more PROX-OPS windows (Lszarev and Damnova (1980)). Strong justification for the permanent installation of such filters should be required in light of the potential perceptual problems associated with what is known as selective color adaptation of the visual system. This refers to the relative inaccuracies of color naming and matching which occur when the eyes are exposed to colored illumination

over even brief periods of time. In general, the ability to correctly discriminate a color through a window having a spectral filter will be degraded if the filter is the same as or close to the color of the object. This could become critical if Shuttle cargo had to be unloaded on the basis of color coding rather than shape.

5.2 LOS Deviation (Prism Effect) and Light Scatter

LOS Deviation. The LOS of the viewer looking through a PROX-OPS window may be altered by a number of factors discussed as follows. One result of such a LOS deviation is that visual judgments of target motion normal to the LOS may be in error. Figure 45 illustrates the often overlooked fact that the apparent direction of a distant target from an observer is determined by the direction which the rays of light from that target enter the viewer's eyes and not the direction they enter the window. The reader is referred to any good text on optics concerning the derivation of prism refraction magnitude as a function of such factors as the angle of incidence of the LOS to the prism's surface, the spectral dispersion across different wavelengths for different types of glass, and other topics.

The implication of such a deviation of the LOS during a PROX-OPS and berthing should be obvious, particularly when the deviation (also known as the refractive) angle varies for different locations within a given window. Distant targets will not be where they appear and apparent motion may be experienced during head translation. If a HUD is used with a spatially conformal symbol of the distant target, the visual target will not correspond in location to it.

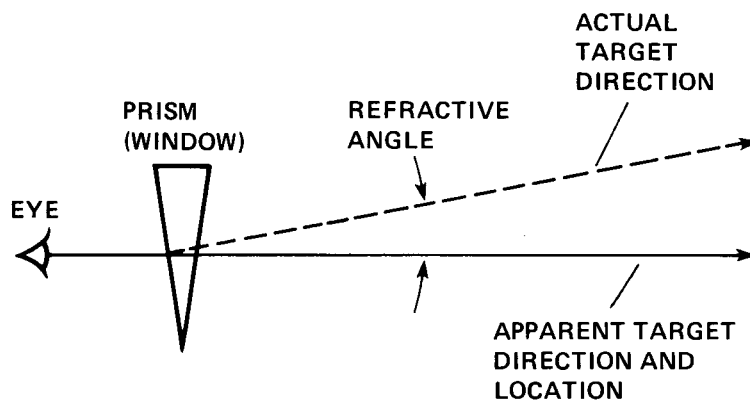

Figure 45.— Illustration of LOS deviation rule.

Sources of a Prism (Wedge) Effect. There are a number of causes of the LOS deviation or prism refraction in spacecraft windows. They include

1. Thermal differential(s): This is the main source according to Gimlett and Garbaccio (1974). Actually, it is the higher-order spatial derivatives of the temperature rather than the gradient (i.e., first derivative) that contribute to the rms wavefront error.
2. Pressure differential: (E.g., outside pressure = 0.0 atm versus approximately 1 atm inside the vehicle.)
3. Glass frame contact design: Numerous framework designs have been studied over the past 20 yr. The interested reader is referred to the Appendix for selected information on the various spacecraft, and to Warner and Walsh (1968) and Kelly (1971).

4. Nonparallel glass surfaces: Several comments are in order with regard to these sources of prism effect. Regarding control of thermal differentials, the Skylab S-190 window was overcoated with an electroconductive film that, when supplied with low current, kept the inner surface above the dew point. This heater was also used to control the distribution of glass temperature.

The orbital position of the spacecraft also influences the thermal differential on the windows. A transient thermal analysis is usually carried out for each mission's altitude and inclination conditions, taking into account various vehicle orientations and stabilization regimens.

An abbreviated list of sources of heat (IR) energy that can induce a deviation in the LOS through a window in space follows:

1. Direct sunlight
2. Reflected sunlight from surface of nearby spacecraft itself and/or from Earth's surface
3. Earth-emitted thermal radiation
4. Direct contact conduction from surrounding skin/structure
5. Air convection inside the vehicle
6. Reradiation from protective shield(s)
7. Electric current applied to surface coating(s) and/or support (seal) frame(s)

For experiments to be carried out during the Gemini project, Warner and Walsh (1968) recommended that a maximum prism (wedge) angle of any pane cannot exceed 4 arc sec and that surface flatness over a 6-in.-diam (15-cm) area in the approximate center of each pane must be within 2.5 wavelengths of sodium light and uniform within 1/8 wavelength. Also see Walsh and Warner (1970) and Gadeberg and White (1968) for optical procedures to measure LOS deviations through windows.

While the optical qualities of PROX-OPS windows should be dictated by the various uses to which they will be put, it is reasonable to design into them as high an optical quality as is affordable in anticipation of future experimental (and other) requirements.

PROX-OPS windows should not introduce a prism (wedge) angle within a circle whose diameter is less than one-half the maximum linear dimension of the window that is greater than 0.05 mrad (10 arc sec). This value is equivalent to a lateral displacement of a target of 1 ft at a distance of 3.4 n. mi. This requirement shall apply for all LOS/window-plane intercept angles within 20° of the LOS normal to the window plane.

It is acknowledged that the above prism angle requirement is somewhat greater than that specified for the Skylab 8190A window (see Space Transportation System User Handbook, 1977). If highly accurate optical measurements will be made through PROX-OPS windows, a prism (wedge) angle of 0.01 mrad (2 arc sec) or better should be provided within that region of the window where the measurements will be made under the pressure and temperature conditions anticipated during flight.

Light Scatter. The subject of light scatter within a window is an extremely important matter which has been discussed elsewhere (Battelle Memorial Institute, 1965; Bechmann, 1958; Bonner et al., 1968; Comstock and Ferrigaro, 1962; Heinisch, 1971; Heinisch and Schmidt, 1970; Muscari et al., 1974; Plunkett, 1970; and Troester, 1968). It may be considered as a subcategory of LOS deviation from a micro rather than a macro standpoint; the physics of photon interaction with very small particles will not be covered here. Heinisch et al. (1970) published details of an apparatus to measure both forward and backward light scatter of collimated light of approximately the same spectral distribution as sunlight in space. Pritchard and Elliott

ORIGINAL PAGE IS
OF POOR QUALITY

(1960) describe a recording polar nephelometer which measures the amount of light scatter from a small region. Figures 46 and 47 illustrate the general nature of scattered sunlight on orbit.

The fraction of scattered light into the observers' eyes due to window contamination must be kept to an absolute minimum which, using the method outlined by Heinisch (1971), will be less than 15×10^5 for viewing angles within 60° arc of the normal LOS through the window and for sunlight penetration angles within 80° of the normal through the window.

A second parameter that plays a significant role in scattering sunlight is the size-density of particles on and inside the glass. Since some particles are transparent (e.g., water condensation), sunlight will be forward-scattered into the eye. Pritchard and Blackwell (1958) present quantitative data on this subject. Other particles can scatter (i.e., refract), reflect, and absorb some light energy. Depending upon many physical parameters, the size and shape of the region on the window that sends scattered light into the eyes can be extremely complex. Keeping all window surfaces as clean as possible is the single most-effective solution to controlling light scatter. The human factors implications of such a solution are not trivial, however.

5.3 LOS Displacement

The LOS is displaced when one views through a glass having parallel surfaces at an oblique angle. Even for relatively thick glass (say 1.5 in. (3.8 cm)), the amount of such displacement will not, in and of itself, produce significant problems related to making most visual judgments. Cibis and Haber (1950) provide

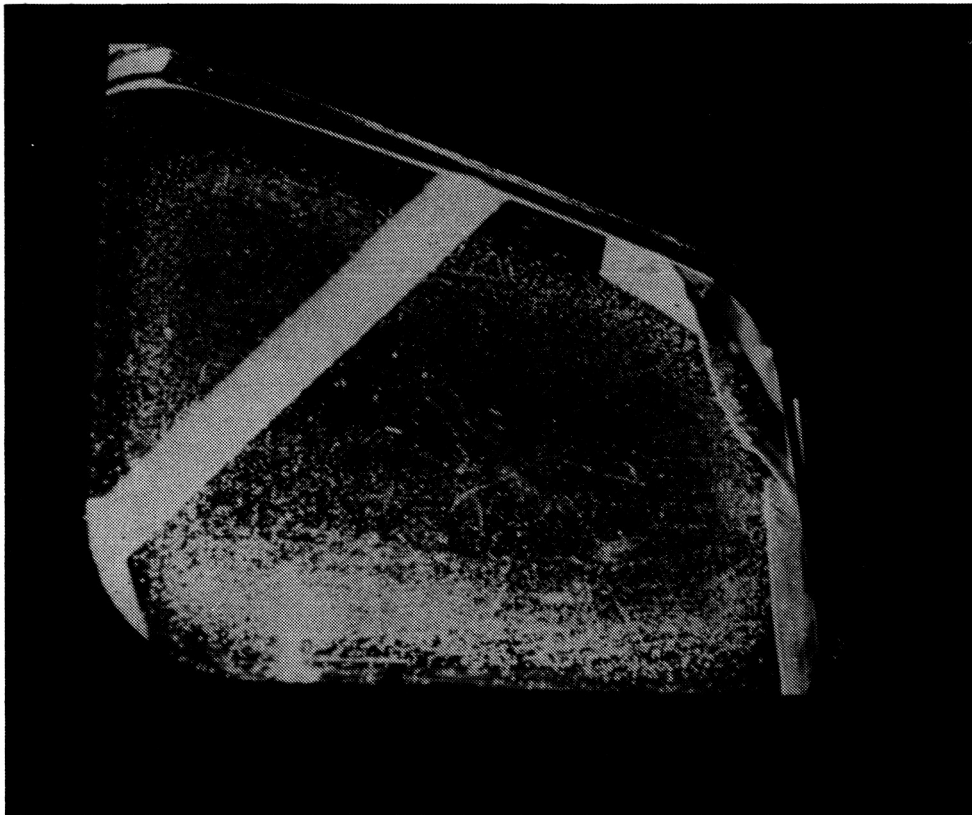

Figure 46.— Moisture condensation on inside surface of an outer windowpane on Shuttle.

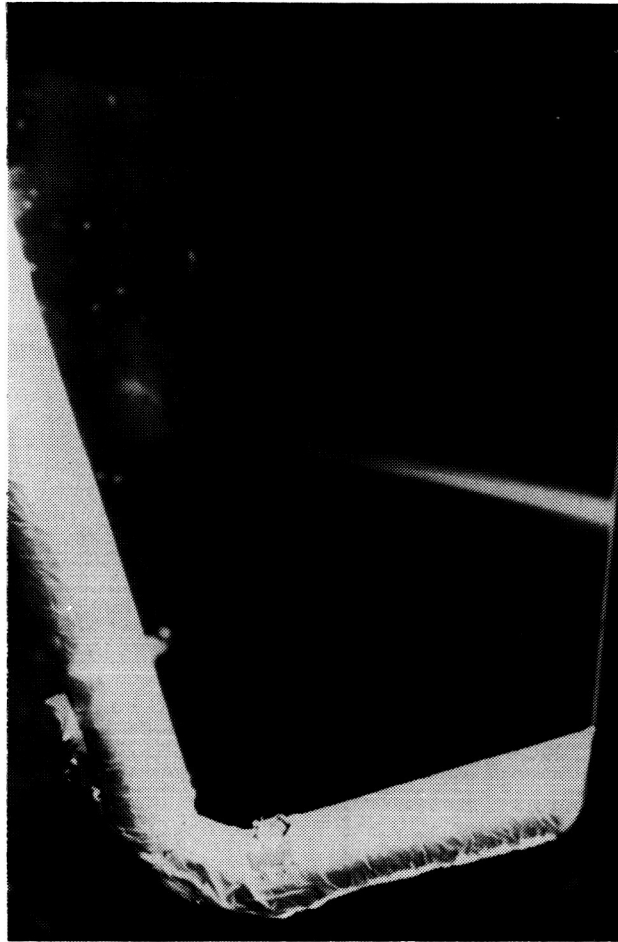

Figure 47.— Shuttle window partially illuminated by sunlight (flight 51-A).

mathematical formulae for calculating the degree to which transparent, parallel, plane-transparent panels will cause apparent changes in the direction, size, shape, and distance of an object. They also provide data on parallax angle changes for two objects located at different distances when the windshield is located between the eyes and the distant object. Parallax angle is the angle between the LOS from each eye when both LOS are converging upon an object; it provides useful cues for judging the distance of objects located within about 20 ft (6 m) of the observer.

In order to provide a general idea of the magnitude of the LOS displacement produced by viewing through a thick, parallel-surface surface, the following test was conducted. A sheet of 0.5 in.-thick (1.3-cm) acrylic plastic was clamped in a base which was graduated in degrees and which could be rotated in position relative to a laser beam. The location of the beam 20 ft (6 m) away was noted carefully. Table 10 presents the results of this test with calculated beam angular deviation for various pane intercept angles.

It should be obvious that the lateral displacement of the image of an object even 1000 ft (305 m) away will be small for LOS inclinations up to 50° from normal to a plastic window. Glass panes will produce approximately equivalent displacements.

TABLE 10.— LASER BEAM DISPLACEMENT AND CALCULATED ANGULAR DEVIATION PRODUCED BY AN INCLINED SHEET OF 0.5-in.-THICK (1.3 cm) ACRYLIC PLASTIC

Beam penetration angle from normal, deg	Distance to target, ft			
	20		200	1000
	Displacement, in.	Angle deviation, min/sec	Displacement, in.	Displacement, in.
0	0	0/0	0	0
10	0.12	1/48	1.26	62.499
20	.16	2/15	1.57	78.74
30	.17	2/25	1.73	86.61
40	.23	3/16	2.28	114.17
50	.24	3/20	2.32	118.1

5.4 Magnification/Minification of Image

If the window assembly produces an image that is larger than the image would be without the window, magnification has occurred. The opposite is true of minification of an image. Two types of magnification must be noted: (1) "absolute" magnification, which is defined by well-known rules of optical refraction (Frank, 1950) and which has nothing whatsoever to do with the eye; and (2) "visual" magnification, which takes into account the accommodative response of the human visual system. Since we are concerned with human factors design of windows, only the second type of magnification is presented here.

The visual magnifying power of an optical system is defined as the ratio of the angle subtended at the eye by the image to that subtended by the same object when it is located at a distance at which it is seen most distinctly. Formulae with which to derive magnification are found in Frank (1950, pp. 315-317). Since each viewer possesses slightly different judgments of what is most distinct, individual differences in visual magnification can be expected for the same window. Such differences should be small.

It is known that an optical instrument used in conjunction with the eye yields the best imagery when accommodation is completely relaxed. In space, almost all objects viewed through the windows will be beyond a distance referred to as "apparent optical infinity"; this point is most commonly taken as any distance greater than 20 ft (6 m) from the eyes. That is, any object farther than about 20 ft (6 m) will lead to an infinity focus response of the visual system.

Of greater concern in a window which magnifies or minifies an object is whether distance/size judgments will be significantly affected. For reasons similar to those presented in section 5.3 with regard to LOS deviation, a magnified object will be judged to be nearer than it actually is. The opposite will be true for a minified object. Therefore, windows should not produce significant values of either type of optical effect.

Window-produced magnification or minification of an image should not exceed a value of 0.1% across the entire window when viewed along a line normal to the glass.

When one views through a glass which has parallel surfaces, but which is slightly bulged along one meridian (e.g., caused by a structural clamping force), the result is known as a "meridional size lens." A lens formed by cupping a plano glass (e.g., caused by a pressure differential and round clamp) is known as an

“overall size lens” (Bartley, 1958). The perceptual result of a meridional size lens is to magnify the scene in one direction, but not in the orthogonal direction. Looking into one end of a hollow cube through a size lens, for instance, one would see an enlargement in one or two adjacent corners (depending upon the dioptric) power and orientation of the lens size. The cube would no longer appear rectilinear. One appearance would be that the wall on the right would appear much farther away than the wall on the left and the ceiling would slope upward to the right and the floor downward to the right. An untoward consequence of viewing through a PROX-OPS window in which there is a meridional size lens effect would be to cause a distortion in perceived target size when viewed through different areas of the window. The translation of a target vehicle across the FOV would appear as a simultaneous change in size and (thus) judged distance.

Both meridional and overall lens size effects should be reduced to a level which is imperceptible to the observer possessing normal vision.

5.5 Astigmatism

Astigmatism refers to the fact that rays passing through a lens along one meridian come to a focal point that is different from rays passing through that lens along a different meridian. A football-shaped lens is such an astigmatic lens. Because of the difference in focal points, the perceptual end result will be image blur and/or simple distortion of the appearance of the distant object. Since the eye cannot focus at two distances at the same time, it will likely seek an intermediate focus between the two optical focal points; visual fatigue may ensue. For these reasons it is best to not allow measurable astigmatism to occur within the PROX-OPS windows.

5.6 Surface Reflections and Haze

Each glass-air interface acts as a partially reflecting mirror to reflect a portion of incident light into the eyes. Such surface reflections can produce distraction and visual impairment under conditions where the reflections

1. Are moving
2. Are colored
3. Are multiple and slightly displaced from each other (the so-called “string-of-pearls” effect)
4. Mask the outside target object
5. Produce erroneous judgments of outside target size/shape/etc.
6. Partially light-adapt the eyes relative to their level of adaptation in the absence of surface reflections

5.6.1 Exterior Light Sources

Light sources outside the Space Station may reflect off one or more windowpane surfaces to produce unwanted secondary visual targets. Such targets can interfere with visual identification and other judgments of luminous targets. For parallel panes and LOS not normal to the panes, the so-called string-of-pearls effect can occur, i.e., a linear array of dim, repeated images of the primary light source. Application of one or more antireflective optical coatings to appropriate glass surfaces can help reduce such reflections.

5.6.2 Interior Light Sources

Several solutions have been developed to help reduce or eliminate surface reflections from interior light sources from windows. They include

1. Using antireflective optical coatings
2. Adding light baffles or shutters
3. Carefully locating light sources (emitted and reflected)
4. Varying the LOS to avoid the reflections
5. Orienting the plane of the window to cause the reflection(s) to not enter the eyes
6. Locating the head so near the window that the head blocks the source of light
7. Turning interior lights off during critical periods of viewing

Considering the high probability that PROX-OPS windows will be numerous and oriented in a wide variety of directions, there is a significant possibility that interior lights will reflect off one or more windows back into the eyes. The human factors related effect of controlling such reflections is not trivial, and careful, full-scale, mock-up research is needed to find acceptable solutions. It would be premature to suggest the best solution at this time.

Moving (Illuminated) Surfaces/People. A source of visual distraction to PROX-OPS viewers will be reflections of objects and people moving behind the viewers and seen by reflection off a window. This will become particularly critical during moving operations in which the outside object or vehicle is very dim, such as can occur on the night side of the orbit. It may be necessary to enclose the PROX-OPS station in a light-tight shield under such conditions. This would help

1. Maintain a state of relative dark-adaptation
2. Reduce or eliminate reflections of moving objects and people

5.7 Sunshades

Physical shutters or shades have been employed on previous U.S. spaceflights to protect windows and sensor ports from damage and contamination. The S190A and airlock windows on Skylab, for instance, had hand-operated protective external covers as did the European Spacelab and the Soviet Salyut vehicles. (Additional information on these devices is contained in the Appendix.)

Since there are so many possible designs for PROX-OPS windows, it is unwarranted to present specific plans for protective sunshades or covers at this time. Nevertheless, it is likely that such shutters will either hinge, pivot, or slide into place as shown in figure 48 (from Bell and Trotti, 1985). Also see Bradley (1981) for further design considerations.

Although opaque covers will prevent any visible solar radiation from reaching the window, the design of such shades should also take into account the need to provide full visibility through the window while also shading it from sunlight. Perhaps a hinged cover should be designed (fig. 48(a)) whose hinge location can be moved around the perimeter of the window frame at will to permit increased freedom of position of shade location.

Solar shades to cast a shadow over the entire window should be considered for PROX-OPS windows as long as they can be repositioned to suit particular FOV requirements and attitudes between the Space Station and the sun.

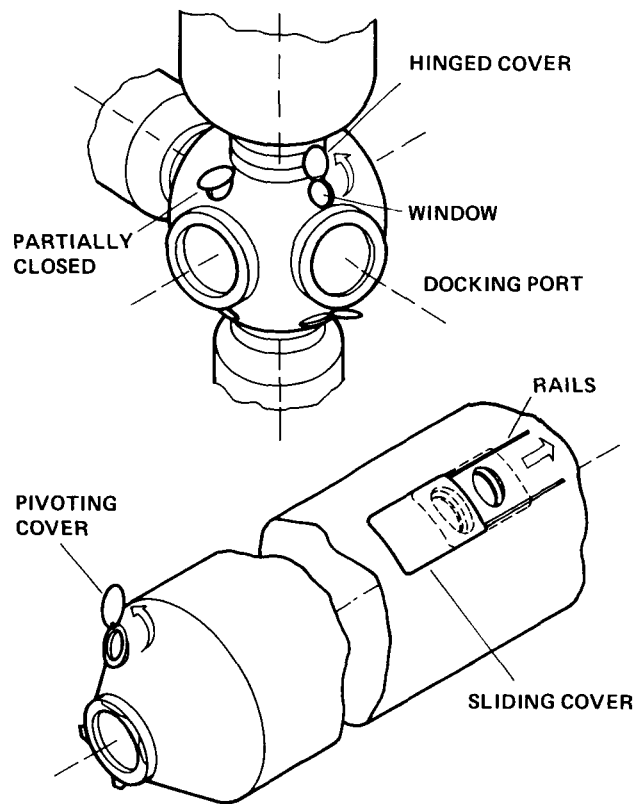

Figure 48.— Examples of external window-cover mechanisms.

6. WINDOW MAINTENANCE AND PROTECTION

The subject of periodic maintenance of all Space Station PROX-OPS windows is an important subject which deserves careful analysis from a human factors point of view. Planning for both the EVA and internal vehicular activity (IVA) associated with window maintenance should begin with an understanding of the types of visual degradation and/or damage that can occur, as well as various means that have been used before to clean the windows. These and other subjects are reviewed below.

Experiment T027 conducted on the first two Skylab missions and reported by Muscari et al. (1974) showed that the sample array of 248 optical surfaces located outside the Skylab vehicle did not collect any significant contaminants. Mass spectroscopy tests showed the presence of only trace amounts of "...high molecular weight species,...[suggesting the] presence of condensed aromatics." It can be noted that the vehicle's attitude-maintenance thrusters directed their exhausts away from the vehicle and would not be expected to contribute to coatings on this array of transmissive windows, mirrors, diffraction gratings, etc. The Marshall Space Flight Center mission report (1974) also presents detailed discussions of window contamination on the Skylab-Saturn Workshop flights (see pp. 11-20 to 11-23). As will be noted in following sections, however, significant optical degradation can be expected to result over time on Space Station optical transparencies.

6.1 Types of Degradation/Damage

This section briefly reviews the sources of window contamination and sources of damage and refers to the Space Station Task Force document (1984) as a primary document. In general, "...contaminants from internal and external sources must be evaluated and monitored. The Space Station configuration, scientific equipment, instrument locations, and operational concepts shall be incorporated in such a manner to be sensitive to all possible effects of contamination....These requirements apply to station zones where sensitive instrumentation will be located or within the field-of-view." (pp. 3-10). The interested reader is also referred to Hass and Hunter (1970) for further detailed information on the result of laboratory experiments to quantify surface contamination and degradation of optical coatings and materials in simulated space environments.

6.1.1 Surface Contamination (Cleanable)

6.1.1.1 Exterior

There are a number of sources of exterior window surface contamination in space that may or may not be cleanable. They may be placed in two groups. Group 1 includes all natural radiation sources in space and group 2 all human-produced contamination sources.

Group 1. Natural Contamination Sources in Space:

- Solar electromagnetic
- Solar particle
- Auroral
- Cosmic
- Van Allen

Group 2. Human-Produced Contamination Sources:

- Vernier rockets for attitude control on Space Station
- Vernier rockets for attitude control and translation on the Space Transportation System, Orbital Maneuvering Vehicle, Orbital Transfer Vehicle, or Space Platform(s)
- Thrusters on MMU or other EVA personnel-transfer equipment
- Spillage during refueling
- Flash evaporator by-products
- Fluid leaks
- Biological and nonbiological waste matter dumped to the outside
- Spacecraft outgassants/cabin leaks
- Thermal-control system
- Hand/footprints produced during EVA
- Artificial radiation (e.g., nuclear burst)

Figure 46 is a photograph from a Shuttle flight showing the influence of condensed moisture on the inside surface of an outer windowpane. Figure 47 shows a Shuttle window partially illuminated by sunlight; light scattered by window contamination significantly reduces visibility through the window.

During EVA to deploy the solar-array wing on day 25 of Skylab's Saturn Workshop, a footprint was left on the outside of airlock window 2, and remained there throughout the mission (Marshall Space Flight Mission Report, 1974). This report also mentioned that a fine dust also coated the outside of all windows on Skylab and "...was probably tiny paint flakes scuffed loose by crewmen during extravehicular activities, as well as the particles of window insulation..." (pp. 11-21).

6.1.1.2 Interior

According to NASA TM-86652 (1984, pp. 3-12), "Efforts will be made to maintain potential internal contaminants to an acceptable level...All internal habitable volumes shall have a control system to provide adequate air circulation and filtration to control air particulate levels to less than 10,000 per cubic foot for particles greater than 0.5 microns in size."

The following internal contaminants that are related to window design were obtained from TM-86652 (1984, table 3-3) and elsewhere:

1. Liquids: water, urine, food juices, spoiled food moisture, breath condensation
2. Semisolids: body/skin oils
3. Solids: skin, hair, metallic particles, inorganic particles
4. Organisms: bacteria, viruses (crew and food origins)

Figure 49 illustrates the significant amount of light that is scattered by contamination on the interior surface of windows and illuminated by sunlight.

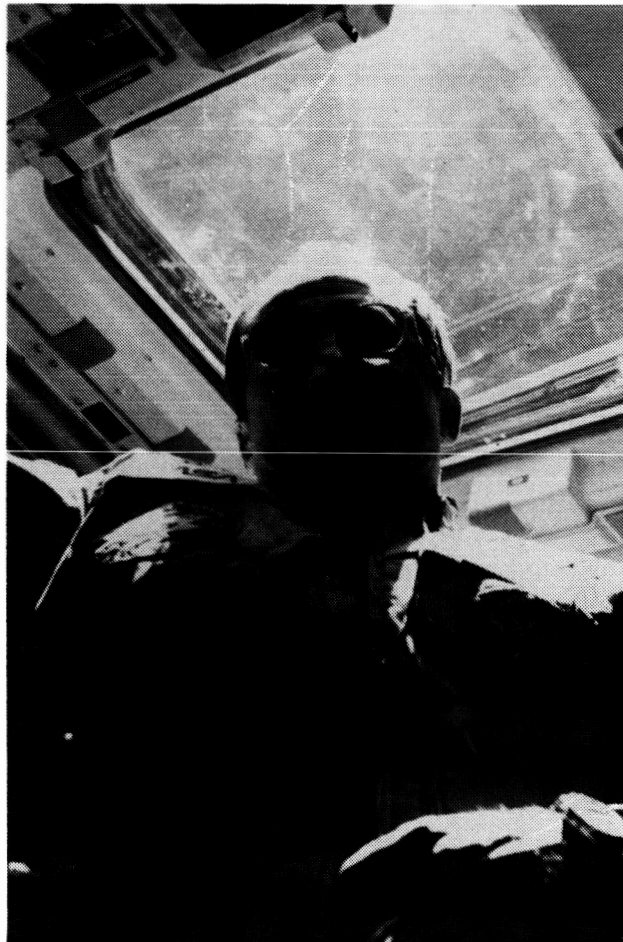

Figure 49.— Shuttle's aft compartment overhead window (flight 51-A).

6.1.1.2.1 Liquids (Breath Condensation)

The transient reduction in window transmissivity and increase in light scattering caused by condensed moisture of human breath on the window surface is not likely to interfere with viewing most external operations because of the relatively long duration of such operations (during which the condensation will disappear) and the possibility of wiping the condensation off if necessary. The former solution is preferred. If the inner surface is to be wiped clean, special preparations will be needed which include specific procedural training for all crewmembers and special cleaning supplies (clean storage/dirty storage).

6.1.1.2.2 Semisolids (Body/Skin Oils)

The PROX-OPS window surfaces must be capable of being cleaned periodically of body oils that are likely to accumulate over time. If antireflective coatings are applied to the inner surface, such periodic cleaning must not affect the optical properties of this coating.

6.1.1.3 Between Panes (Gasket and Other Outgassing Sources)

Outgassing studies have been conducted on a wide range of materials considered for use in space. Studies have been conducted on polymers (Muraca and Whittack, 1967); nonmetallic materials (McPherson, 1967); 98 different space cabin construction materials (Pustinger and Hodgson, 1967); and 150 candidate materials for the Apollo capsule (Bolstad et al., 1963).

For example, it is known that RTV560TM used to seal the windows of the Apollo vehicle "...severely contaminates the window by outgassing. High-temperature-cured RTV560 is much worse in that respect than room-temperature-cured RTV560." Heinisch and Schmidt (1970) point out that the properties of the condensate are "drastically changed" by polymerization caused by impingement of solar UV.

Window-surface contamination scatters sunlight into the observer's eyes and produces a veiling luminance (glare) which reduces his or her ability to detect faint visual targets such as navigation stars (see section 5.3).

6.1.2 Surface Contamination (Noncleanable)

6.1.2.1 Exterior

The Space Station Task Force document (1984) provides a list of requirements concerning external contamination with limits for "column densities," "background light level," "particle release," and "deposition of station generated matter as a result of direct or atmospheric scattering" (tables 3-1 and 3-2). From the human factors design standpoint it will be assumed that part of the contaminant-monitoring procedures will be carried out using the PROX-OPS windows for those sensors located within the FOV of these windows. It is also assumed here that the molecular particulate levels listed in table 3-1 of the reference document will be maintained at or below the listed amounts.

6.1.2.1.1 Rocket Plume Impingement (Solid, Liquid)

Plume impingement on all orbiting elements should be maintained at the lowest possible levels (Donahoo and Anderson, 1985). The window-related human factors implications of this requirement include:

1. Window design penalties related to protective covers/systems (weight, reliability of actuators, etc.)
2. Human work load associated with cleaning windows

3. Human work load associated with replacing outer pane(s)
4. Crew time required to clean outer pane
5. Crew time required to replace outer pane
6. Availability of protective window covers on board
7. Storage and periodic inspection requirements of protective window covers, outer panes, spare actuating parts, etc.

It would seem to be unfeasible to place all PROX-OPS windows in such locations that plume impingement would be impossible. It is more likely that window outer surface degradation will simply be seen as another standard operating factor that must be coped with in the best manner possible. Perhaps automatic plume-impingement sensors could actuate protective covers quickly and thereby reduce the rate of contamination buildup over time.

6.1.2.1.2 Other Sources

Another known source of external window contamination is from the ablation heating processes produced during reentry into the atmosphere. While this source is not directly relevant to Space Station, the reader may want to consult Bonner et al. (1968) for discussions on measured contaminants on various Gemini flights. These authors determined that it is unlikely that the ablation by-products which were found after the flight were from heating during the launch phase.

6.1.3 Permanent Surface Damage (Requiring Replacement)

The Space Station Task Force document (1984, p. B-4) specifies that the Space Station "...shall be designed for at least an 0.95 probability of no penetration from meteoroids during the maximum total time in orbit, using the meteoroid model defined in section 2.6 of TM X-82478." Based upon the above, there is a 5% chance that internal air pressure will change unexpectedly and abruptly because of micrometeorite penetration of the Space Station during its maximum total time on orbit. The central concern for this report is the probability that this penetration will occur at a window. The answer to this will depend upon such parameters as total window area versus total Space Station external surface area; window surface orientation relative to the Earth's surface, which will block incoming meteorites; window location on the Space Station relative to shielding by the Space Station's structure; and impact energy absorption capability of the windowpane(s). These subjects are beyond the scope of this report. Reports by Cour-Palais (1973, 1979) and Cour-Palais et al. (1972(a) and (b)) further describe test results of micrometeoroid impacts on Skylab/Apollo windows.

Plans must be made on how the crew will deal with window damage of all kinds. The following sections deal with window breakage of one or all panes in an assembly, spectral transmission changes, thermal shock breakage, and other causes of degradation. Salyut 6 experienced a micrometeorite impact on a window causing a 0.16-in.-deep (4-mm) crater. The window assembly did not rupture (unpublished report, "Soviet Space Station Analogs," B. J. Bluth, 1985).

6.1.4 External (Pressure Pane) Breakage

This report does not treat those factors which determine the physical strength of glass as a structural material. However, because various treatments, such as optical coatings, that are applied to windows to reduce reflections, etc., affect the ability of glass panes to withstand stress, it is important to briefly discuss the matter.

The strength of both tempered and annealed glass is defined by the modulus of rupture (MOR). Pigg and Weiss (1973) define the MOR as the short-time breaking stress of glass caused by bending in a moist

environment. To determine the MOR for a given sample, it is first abraded (to represent the worst-case flaw expected for that pane) and then subjected to mechanical flexure using an applied load upon a rigid surface having a fixed radius of curvature. This rigid surface is then applied (at a point) to the glass pane suspended between two parallel rollers, each of which contact the glass along a line. This mechanical flexure test determines the amount of bending of the glass just prior to and at fracture.

It is a characteristic of tempered glass that when it fractures it is completely destroyed. This feature would suggest that tempered glass should be reserved for only relatively small windows to help reduce interior atmosphere loss rate in the event of fracture. Such a design recommendation is only provisional, however, until further work is performed. See Wiederhorn et al. (1974) for more information on a study of fracture mechanisms of Skylab windows and Eardley (1970; 1972) for probability of fracture of the Skylab windows.

6.1.5 Puncture of All Windowpanes (Pressure Loss)

The catastrophic rupture of all window panes in a given assembly would severely affect overall mission safety and performance integrity. From a human factors design standpoint, window area should be as small as possible to reduce the air volume loss rate (Irvine, 1969). However, this requirement must be balanced by the need for providing as wide a FOV through any PROX-OPS window as possible. If the setback distance can be kept as small as possible (say from 6 to 12 in. (15 to 30 cm)), then FOV widths ranging from 75° to 115° arc will be possible for an 18-in.-wide (45-cm) window (see section 4.4.3, figs. 23 and 26). If larger setback distances are necessary, larger windows will be required.

Windows may be punctured from unplanned IVA operations; all IVA operations should be analyzed to help reduce this possibility. A candidate list of possible IVA operations which could contribute to window rupture includes

1. Rapid, transient, internal air-pressure increase
2. Explosion projectiles
3. Inadvertent, crew (body) contact against an inner plane

Windows may also be punctured by collision with various kinds of space debris. Kessler (1981) provides calculated debris flux (impacts that may be expected per square meter of spacecraft surface area per year) as a function of orbital altitude. The flux levels are *not* trivial. He points out that as of December 31, 1979, 11,665 objects had been "...officially launched into space." Of these, 4549 were still in orbit as of mid-1980. In another paper, Kessler and Cour-Palais (1978) mention that this "debris" is made up of three types of objects: (1) payloads, (2) rocket motors, and (3) debris associated with the launch or breakup of a particular payload or rocket. Since many of these objects are in orbits that cross one another, "...there is a finite probability of collisions between them" (p. 2637). The mass of such debris is great and poses a genuine threat to window integrity in the event of an impact. Kessler and Cour-Palais (1978) have proposed a satellite environment model which the interested reader may want to consult. Clanton et al. (1980) have analyzed hypervelocity impacts on Skylab IV/Apollo windows. Harris and Reecks (1963) report a method of impact-testing of window glass material. Finally, Sampson (1969) provides results of photoelastic evaluation of wire-reinforced flexible windows.

Each PROX-OPS window assembly shall be capable of withstanding a blunt-object impact load of 550 N from any angle of incidence.

6.1.6 Spectral Transmission Change (Radiation/Thermal)

The coloration of various glasses by ionizing radiation is well known and has spurred the design and development of special radiation-resistant glasses and solar window covers. The interested reader is referred to several annotated bibliographies on this complex subject (Battelle, 1965; Bechmann, 1958; Comstock and Ferrigaro, 1962).

It is known that optical transmission changes occur in borosilicate BK-7 glass (e.g., on the Skylab experiment S-190 window) over the visual spectrum as a result of electron bombardment of varying energies (Braly and Heaton, 1972). The effect is sometimes known as radiation coloration. Uncoated BK-7 glass showed the greatest reduction in transmission, for all electron energies, at shorter wavelengths. Figure 50 (from Braly and Heaton, 1972, fig. 7) presents one set of data to illustrate the general nature of the findings of these researchers.

Neu et al. (1968) present ground irradiation results on the Apollo window materials (fused silica, Corning Code 7940, UV Grade; Vycor, Corning Code 7913, Optical Grade; and aluminosilicate glass, Corning Code 1723). Irradiation levels simulating those of a 30-day Apollo mission on-orbit produced "significant changes in transmittance." They summarize their transmittance results as follows (p. 70):

One observes a sizeable reduction in transmittance of all three materials in the ultraviolet region of the spectrum and very little change in the infrared region. The lowered transmittance of the coated samples after irradiation follows that of the uncoated samples indicating that the increased absorption results mainly due to changes in the bulk material (glass) rather than the coatings. Little visible darkening was noted in any of the irradiated samples.

The PROX-OPS windows should not change in optical transmission across the visual spectrum (0.4–0.9 μm) within the first 12 mo on-orbit by more than 3% and not more than 1%/yr thereafter.

The human factors consequences of such changes larger than 3% will largely be determined by the time rate of change of transmission at each wave band and by differential transmission changes across the visual spectrum. It is not anticipated that precise color (hue) visual judgments will need to be made while looking through a PROX-OPS window. Nevertheless, simultaneous color comparisons may have to be made through a single window of cargo within the Shuttle's cargo bay in order to visually identify which cargo is to be removed. Use of optimal color and brightness contrast markings on all cargo to be visually discriminated through the PROX-OPS windows will be required; adequate, general, white floodlight illumination into the cargo bay will also be required (see sections 3.1.1, 3.2.1, and 3.2.2).

6.1.7 Thermal Shock Breakage

Spacecraft windows are subjected to short-term and long-term thermal loads (shock) which subject the glass to differential stress and accompanying optical (e.g., LOS deviation) changes. In addition, certain optical coatings change the thermal-shock-resistance characteristics of glass. For present purposes of discussion, short-term thermal load refers to the heat load produced by atmospheric friction during reentry. As such, the Space Station windows will not be faced with short-term thermal load. Nevertheless, it is possible that rocket plume impingement from the Orbiter may impose low-level, short-term thermal shock on these windows. Long-term thermal loads refer (generally) to much longer and lower temperature changes that are produced by direct and reflected solar radiation on the day side of the orbit. Arduini (1968) discusses thermal control of spacecraft windows. Of particular concern is the possibility of multiple solar reflections falling upon a given window. It is possible to achieve very high surface temperatures if care is not taken to shield the

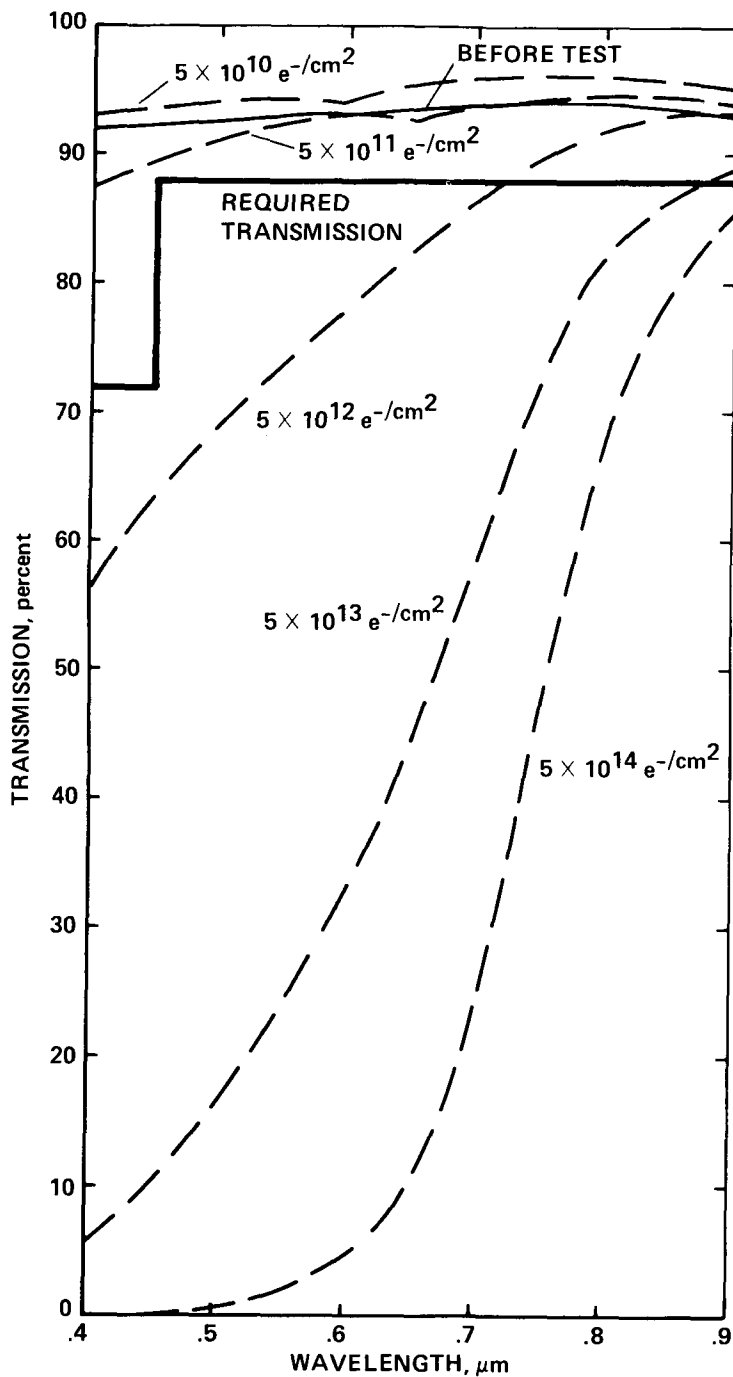

Figure 50.— Transmittance of irradiated uncoated samples of BK-7 borosilicate glass.

window(s) from such sources and/or design all specularly reflecting surfaces so that they cannot focus solar radiation onto these windows. Wiederhorn et al. (1974) provide data on the fracture properties of an ultralow-expansion glass (two-component silicate glass) considered for use on the Shuttle windows that would be subjected to the heat of atmospheric reentry. What is important from a human factors point of view is the fact that for these particular test conditions, the crack velocities ranged from 4×10^{-3} in./sec to 4×10^{-10} in./sec, which is very slow and likely is well below the motion threshold of the observer. Thus, if a crack was noticed at all it should be measured immediately and/or otherwise documented. For a 25-in.-wide

(64-cm) window that has a developing crack parallel to the 25-in. (64-cm) side, an average fracture propagation rate of about 4×10^{-7} in./sec is equivalent to 0.03 in. (0.08-cm)/24-hr day or 3.06 in. (7.8 cm)/90 days.

It is recommended that a periodic window-integrity inspection be carried out on all PROX-OPS windows.

As the exterior and interior window surfaces become increasingly pitted, sand-blasted, and overcoated by various substances, the appearance of cracks will be more and more difficult to discriminate. Figure 51 illustrates this general effect (which is the aft cabin bulkhead window on the Shuttle).

It is recommended that an automatic window-integrity monitoring capability be developed with a self-test feature with pass/fail criteria and suitable failure annunciation of the monitor system. Such failure should be visually annunciated.



Figure 51.— Shuttle aft bulkhead window illustrating light-diffusion effect due to surface contamination.

Heinisch and Schmidt (1970) presented a method for window-surface cleaning of *isolated* window-panes. It involves the following steps:

1. Soak the glass for several hours in hot MICROTM detergent solution.
2. Rinse and rub with wet cotton swab, using deionized filtered water (repeat this step several times).
3. In a final step, cover the glass surface with deionized water; blow off with a jet of dry nitrogen.
4. Inspect the cleaned surface by directing a bright collimated beam of light on the surface and view the surface against a black background in a darkened room.

The Vycor Apollo windows were cleaned by NASA (unpublished North American Aviation, Inc., Report No. 03935) on the launch pad using the following steps:

1. Air-blow all glass surfaces with a gentle stream of clean, dry air from a hand-operated rubber aspirator or syringe, or with a bottle of compressed dry argon or nitrogen gas to remove loosely adhering particles.
2. Wash surface with distilled water to remove deposited salts and the remaining dust particles.
3. Wash surface with chemically pure methyl ethyl ketone to remove any organic stains such as transferred adhesive from the protective paper on the window (from manufacturer), fingerprints, or other body oils.
4. Wash surface with chemically pure isopropyl alcohol (final washing step) to remove any residues from previous washings.
5. Inspect the surface by reflected light using a 12-in.-long (30-cm) fluorescent tube inside a metal tube having a 1/16- by 4-in.-long (0.15- by 10-cm) milled light slit running lengthwise. Use this light source to reflect light off the surface into the eyes. The uniformity of the color of reflected light will indicate the degree of cleanliness.

The general washing procedure for the above window-cleaning steps involves the following actions and details:

1. Saturate an absorbent cotton ball or the equivalent with methyl ethyl ketone.
2. Wash a small section of the window at a time, applying sufficient pressure to release the desired amount of liquid so that running does not become excessive.
3. Immediately wipe the washed portion of the window with a clean, dry, lint-free, soft cotton cloth to absorb all of the methyl ethyl ketone before it evaporates.
4. Repeat the process until the window has been washed with methyl ethyl ketone before proceeding to pure isopropyl alcohol.
5. When this cleaning procedure has been completed, examine the window for uniformity of cleanliness. If dirty areas remain, they may be spot-washed using the same procedure as above.

6.1.8 Other Degradation Causes

There are several other potential sources of window degradation and failure. They include simple fatigue fracture (either of the glass itself or the clamping frame member(s) surrounding the glass; optical-coating scratches on the inner pane during Space Station operation; failure of the seal at the clamp (see Campanile, 1965); or accidental physical contact.

6.2 Candidate Methods of Maintenance

6.2.1 Hand-Cleaning

Since it became apparent that spacecraft windows were contaminated during spaceflight to the point that visibility through them was significantly degraded, cleaning methods have been developed. A Soviet cosmonaut on Salyut 7 used his handkerchief during EVA to wipe off a window (Chaikin, 1985).

During the Skylab flight (NASA TM X-64814, 1974), residues from condensation and smudges from crew contact were removed from the interior window surfaces with water and wet wipes, "...which was a very effective technique" (p. 11-21).

6.2.2 Mechanical Polishing/Buffering

It is possible that periodic mechanical polishing and buffing of window surfaces will partially restore them to an acceptable optical quality. This is likely to be true for the very fine micrometeoroid abrasion that occurs over time on-orbit. Such operations will not correct the optical or visual perceptual problems associated with larger craters or surface scratches, and may even produce unwanted prism effects. If windows are polished periodically, means should be provided to verify that LOS deviations remain within required levels following each such operation. Unless and until specific, clear instructions can be developed along with the required polishing/buffing equipment, such operations are not recommended since they are likely to do more damage than good, particularly with regard to damage to optical coatings which may be on the outer windowpane.

6.2.3 Pane Replacement

The possibility of replacing one or more windowpanes on-orbit should be seriously considered for Space Station's PROX-OPS windows. A comprehensive, engineering tradeoff study is called for which would show the benefits and liabilities of total replacement on-orbit in the event of loss of transparency (grazing, abrasion, coating discolorations) or loss of structural integrity (cracking, total fracture). The human factors impact of such on-orbit window assembly replacement would occur in (at least) the following areas:

1. Internal pressure loss/control/replacement during the window assembly change and all human activities associated with preparing for this pressure change (e.g., donning pressure suits, egress from affected module, pressure-sealing the affected module from other modules, monitoring the internal (temperature, humidity, pressure) atmospheric status during replacement)

2. Storage (design, construction) of window spare parts on-board, manual operations required to unstow repair hardware and installation tools

3. Manual operations required to remove old windowpane assembly and install new assembly

4. Procedures required to stow old windowpane assembly. It is likely that the old pane would first be inspected and documented to establish the precise cause of the problem(s)

5. Procedures required to verify the final installation integrity prior to safety-rating the module with the new window assembly

6.2.4 Full-Window-Assembly Replacement

Many of the human factors considerations just discussed with respect to single-pane replacement on-orbit apply to the replacement of an entire window assembly made up of two or three panes sandwiched within a frame that is to be installed into the Space Station's wall structure. While it would seem that such a procedure would be so difficult as to preclude it from initial consideration, I believe that it could be the most effective means of window repair over the long-term operation of the Space Station. The mission cost of full-window assembly would include the following elements:

1. Weight and space penalties for storing one or more full window assemblies on board the Space Station.

2. Standardizing the size, shape, and installation details of all PROX-OPS windows so as to permit full (or partial) interchangeability among all spares.

3. Human factors considerations related to replacing the entire window assembly versus two or three separate window panes within the frame assembly. For example, how long would it take to replace two glass panes in an existing frame versus replacing the entire frame which already contains the two new panes?

4. Maintenance of internal pressure integrity during replacement of an entire window assembly versus one pane at a time.

It may be justified to consider having one or two emergency repair kits on board which would consist of a solid metal plate that would pressure-seal on the outside of the Space Station over the entire window assembly, spare windowpanes that could be installed for damaged panes from the inside of the Space Station, all required gaskets and sealants, and all required tools and safety-rating checkout equipment.

Figure 52, from Bell and Trotti (1985), shows several candidate techniques for partial or total window replacement using standardized window module dimensions and cleverly designed clamps and fasteners. Whether the window should be removed toward the inside of the module or toward the outside is a key issue and deserves careful study.

6.2.5 Replaceable Shield(s)

The Soviets are reputed to have tried a flexible, peel-off film over capsule windows. It is not known whether this approach was considered successful. The benefit to be gained from using such an approach must be balanced against such factors as

1. Crew work load to locate, unstow, and apply such a shield, including all associated EVA activities (suiting up, pressurizing, air-lock and egress activities, etc.)
2. Crew time to locate, unstow, and apply such a shield
3. Possible damage to optical coatings on outer window surface
4. Spares storage, inventory, periodic inspection and maintenance
5. Possibility of long-term lamination of shield to window surface

Considerably more research is called for on this subject before such a technique should be implemented.

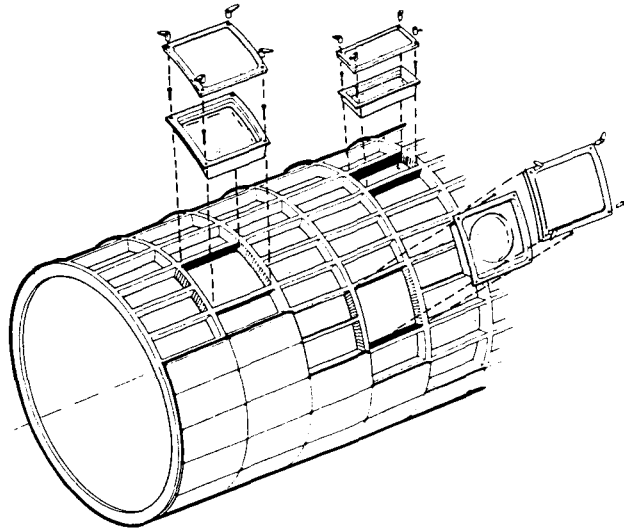

Figure 52.— Window assembly replacement concepts.

6.3 Candidate Methods of Protection On-Orbit

A mechanically controlled hinged, metal shutter has been used on Skylab's Multiple Docking Adapter (MDA) window facing the Earth as part of an experiment involving the S190 Earth resources multispectral camera. Details are found in Trent and Rothermel (1974). Bell and Trotti (1985) have illustrated three basic shutter mechanism designs (see fig. 46).

6.4 Crew Safety Threats Related to PROX-OPS Windows

The list of crew safety threats of Percy et al. (1985) was reviewed from the standpoint of the PROX-OPS windows. Following is a list of the threats considered to be related to these windows. Items marked ++ are considered highly relevant and deserving of design consideration. Items marked + are considered only moderately important, and those without any such mark are cited only because of a possible secondary effect; i.e., in the case of electrical shock that might be transmitted to a viewer via a window frame.

- ++ Leakage (of air pressure)
- ++ Grazing/collision (producing window rupture)
- ++ Mechanical damage (producing window rupture or cracking)
- ++ Explosion (producing window rupture or cracking)
- ++ Loss of pressurization
 - + Radiation (and concomitant thermal-related stress changes)
 - + Out-of-control IVA/EVA astronaut (producing window rupture)
- ++ Meteorite penetration (producing window rupture)
- ++ Structural erosion (adversely affecting window integrity)
- ++ Temperature extremes (adversely affecting window integrity)
 - + Debris (contaminating external surfaces)
- Electrical shock

As Percy et al. (1985) state, there are several methods one can use to deal with some of these residual threats, the best of which is the development of new technology. A second is to apply already proven escape and rescue options. Most of the above threats are directly or indirectly related to loss of interior pressure

rather than loss of visibility through the window(s) affected. From this point of view the window must be considered as merely another structural member similar to the exterior skin of the Space Station. This subject is beyond the scope of this paper.

7. CONCLUDING COMMENTS

Space Station PROX-OPS windows which will be used to support a wide range of visual and optical sensor tasks over a prolonged period of time on orbit must be designed to permit limited or whole assembly replacement. Cost-benefit tradeoff studies must be carried out to justify the details of such designs. Nevertheless, the relative mechanical complexity of the surrounding metal and nonmetal clamps for windows that have been used to date suggests that not only is a new approach needed, but that the human factors engineer should be involved in the design at the earliest possible stage. The human's role in window maintenance and replacement will not be trivial.

In the appendix, window details are provided for both U.S. and Soviet spacecraft. It should be noted that these window designs were *not* intended to allow repair or replacement in flight. In contrast, Space Station windows must be carefully designed to permit periodic maintenance, repair, and replacement.

Ames Research Center
National Aeronautics and Space Administration
Moffett Field, California, August 1986

APPENDIX

WINDOWS USED IN PREVIOUS SPACE VEHICLES

Details of windows that have been installed on previous NASA and Soviet manned spacecraft are discussed in this section. Each discussion is preceded by a tabular presentation of the windows on the applicable spacecraft.

Mercury

Mercury Capsule (Zink, 1963)

Pane 1 (outermost)

Name: Forward viewing window

Dimensions: 12.4 in. (31.5 cm) high by 10.6 in. (27 cm) (bottom) by 7.3 in. (18.5 cm) (top)

Material: Corning Vycor

Other: Curved to conform to capsule mold line

Pane 2 (inner)

Name: Forward viewing window

Material: Corning Vycor, flat

Coating: Antireflecting

Panes 3 and 4

Name: Forward viewing window

Material: Tempered glass, flat

Coating: Antireflecting

Walter M. Schirra, Jr. writes concerning the windows on the Mercury capsule (Carpenter et al., 1962, pp. 90-91):

We closed ranks with a whole bag of complaints when we made our first trip to the McDonnell Aircraft plant in St. Louis and got our first look at the capsule that McDonnell was building. The preliminary design had been roughed out before we were chosen, and the engineers were already putting some mock-up models together when we got there....the main thing that bothered us was that for some reason the engineers had decided not to provide us with a window so we could look out and see the view. It seems that some engineers just don't think the way a pilot does. It might have been a lot easier — and maybe a little safer — to build a spacecraft with no window in it at all. The engineers did claim that they had tried to design one for us but were afraid the tremendous stresses and heat we would encounter in space might crack it. They also pointed out that they had already stuck on a periscope and a couple of small portholes for us to look through. But that just wasn't good enough. We all felt that a pilot ought to have a clear visual reference to his surroundings, no matter what kind of a craft he's flying. Otherwise he would have trouble keeping his bearings and maneuvering with real efficiency. None of us wanted to die of claustrophobia out there in space, and none of us could see any point in going to all the trouble to get out there in the first place if we were going to be half blind. We were persistent, and we finally got our way. The engineers built us a window.

During the first American suborbital flight by Alan B. Shepard, Jr., on May 5, 1961, the Mercury capsule possessed a periscope (not discussed here) and a 10-in.-diam (25.4-cm) round (porthole) window. As discussed above, subsequent Mercury capsules had two larger windows (described below). These early NASA missions provided a wealth of scientific and experiential data about human vision in space and of the Earth's surface from orbital altitudes. The interested reader can find commentaries on these early flights in Jones and Hann (1961); Voas (1961); Zink (1963); and Wolfe, (1979).

In the Mercury capsule the window located above and forward of the astronaut's head was 12.4 in. (31.5 cm) long, 10.6 in. (27 cm) wide at the edge nearest the astronaut's eyes, and it tapered to 7.3 in. (18.5 cm) at its farthest edge. The effective FOV provided by the Mercury window at the nominal DEP was 33° arc longitudinally and 54° arc laterally at the near edge and 22° arc at the far edge of the window. Zink (1963, p. 15) points out that "The window consists of two assemblies, an outer one of a single layer of Vycor (Trademark [sic]) glass curved to conform to the mold line of the capsule. The inner assembly consists of a single flat layer of Vycor glass and two inside layers of tempered glass, each coated with an anti-reflectant. The window is phase polarized along the horizontal axis by means of a polarized filter. (Reduction of light transmission is equivalent to that of the Earth's atmosphere.) A red plastic filter and a solid shield, which can be swung out of place by the astronaut, make up the last two layers of the window system."

Gemini

Gemini Capsule (Bonner et al., 1968; Warner and Walsh, 1968; Zook et al., 1970)

Pane 1 (outermost)

Name: Right-hand

Dimensions: Approximately 15.75 in. by 8.5 in. (40 cm by 21.6 cm)

Material: Corning Vycor 7913 fused silica

Thickness: 0.330 in. (0.84 cm)

Coating: exterior – uncoated, interior – antireflecting

Panes 2 and 3 (center and inner)

Name: Right-hand, Center pane (2), Inner pane (3)

Dimensions: Approximately 14 in. by 8 in. (35.6 cm by 20.3 cm)

Material: Corning Vycor 7913 fused silica

Thickness: 0.380 in. (1 cm)

Coating: all four surfaces, antireflecting

Miscellaneous: MIL-O-13830 (1982) and MIL-G-174A(2) (1979) used for baseline optical requirements.

Right-hand optical window had to be flat to 1.5 wavelengths (540 nm) over a 5-in.-diam (12.7-cm) circle; 3.0 wavelengths over rest of window; LOS deviation no larger than 1 min arc.

Valuable information about the Gemini capsule windows is found in Bonner et al. (1969) who performed transmission, schlieren, and resolution tests on the Gemini VII, VIII, IX, and XII right-hand hatch windows. These windows were designed to have very high optical quality within a 6-in.-diam (15-cm) circle in the center of this window. Figure 53 is a cross-sectional drawing of the Gemini window showing the method of clamping each of the three panes.

Figure 54 shows Lt. Col. Thomas P. Stafford during the Gemini 9 flight and illustrates the highly constrained head position relative to the window as well as the relatively short setback distance.

Figure 55 (from Bonner et al., 1968) presents the results of the spectral transmission tests on the Gemini IV, V, VI, and VII windows to illustrate the differences obtained by Bonner et al. (1968) for four angles of incidence from the normal. Greater transmissivity was achieved when viewing along a LOS normal

ORIGINAL PAGE IS
OF POOR QUALITY

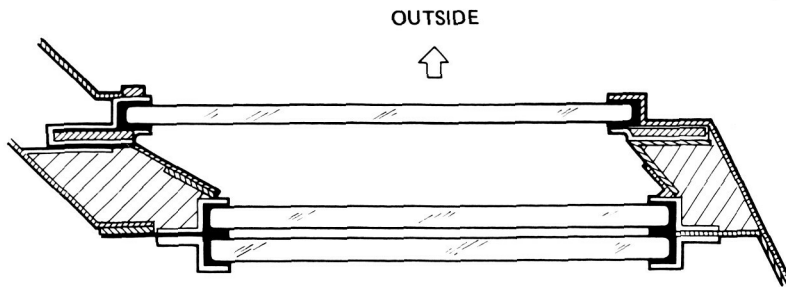

Figure 53.— Gemini spacecraft window clamping method.

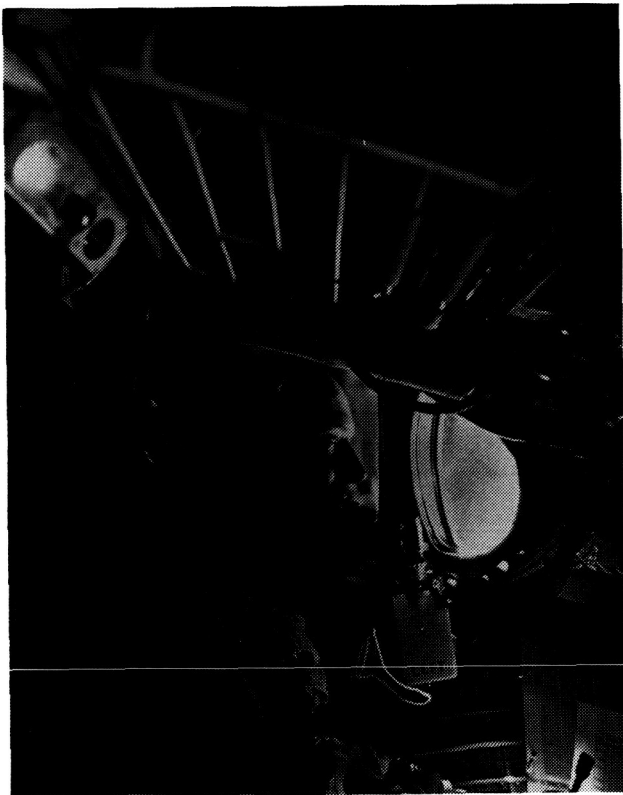

Figure 54.— Lt. Col. T. P. Stafford looking out left-hand Gemini window during GT-9 flight.

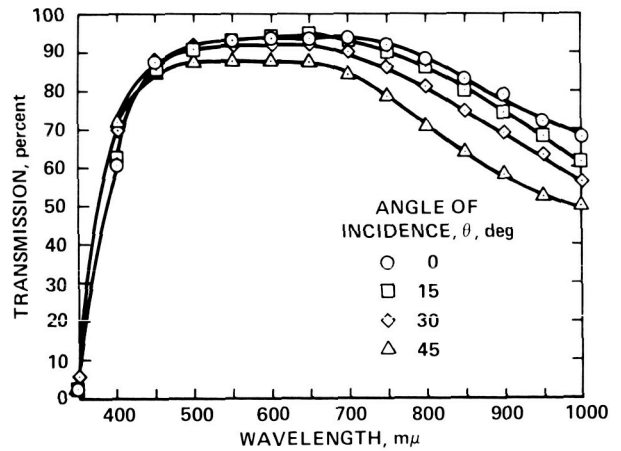

Figure 55.— Optical transmission at four incidence angles for clean, left-hand Gemini window.

to the plane of the glass across most of the visible spectrum. Bonner et al. (1968) also provide spectral transmission data across dirty (post-flight) right and left windows for the Gemini IV through VII flights and for a clean right window.

The schlieren test involves measurement of disturbances of the air in the light path of an interferometer which changes the density of the air and, consequently, the light pattern that is produced. Variations indicate glass surface irregularities, variations in the index of refraction, flaws, and/or nonparallelism of the surfaces. This report presents photographs of the resultant schlieren tests.

For tests of optical resolution a high-contrast-resolution chart (National Bureau of Standards) was photographed as was a U.S. Air Force bar chart for the Gemini VII, VIII, and IX windows. A telescope

with a 1400-mm focal length was used at the lens of the 35-mm (constant f-stop) camera. Relative resolution was defined as the ratio of the resolution of the system without the window to the resolution with the window, without refocusing the telescope. Resolution in lines per millimeter and resolution loss in percent along the horizontal and vertical meridians were presented. For Gemini VII, VIII, and IX the resolution in the horizontal dimension was 68, 56, and 56 lines/mm, respectively. For the vertical dimension it was 40, 56, and 56 lines/mm, respectively.

Smith and Lampkin (1968) report their findings on the accuracy of hand-held sextant sighting measurements from on board the Gemini XII spacecraft's right window using a specially designed sextant. This work was done in support of NASA experiment T002 and USAF experiment D-9. The resolution of this window was 31.2 lines/mm horizontally and vertically. They found that the angle between stars can be measured, "...with a hand-held sextant. The total measurement error (astronaut + sextant + spacecraft window) had a standard deviation of less than ± 10 arc sec and an average mean [sic] sighting measurement error of only 2 arc sec." The interested reader may also want to consult Murtagh et al. (1967); Silva et al. (1966); and Walsh et al. (1966) for further information on this subject.

The reader is also referred to Warner and Walsh (1968) for details on the influence of window-frame clamping (constraints) on such optical parameters as flatness, wedge angle, LOS deviation, resolution loss, and distortion of a flat wave front caused by a simulated pressure differential.

Apollo Command Module

Apollo Command Module (Leger and Bricker, 1972; Pigg and Weiss, 1973)

Pane 1 (outermost)

Name: Hatch (heat shield)

Material: Silica, 99% amorphous

Thickness: 0.7 in. (1.8 cm)

Coating: exterior – MgF_2 , interior – blue-red coating

Panes 2 and 3 (center and inner)

Name: Hatch

Material: Aluminosilicate glass, tempered

Thickness: 0.23 in. (0.58 cm)

Coating: (HEA) antireflecting

Pane 1 (outermost)

Name: Side window

Material: Silica, 99% amorphous

Thickness: 0.7 in. (1.8 cm)

Coating: exterior – MgF_2 , interior – blue-red coating

Panes 2 and 3 (center and inner)

Name: Side window

Material: Aluminosilicate glass, tempered

Thickness: 0.25 in. (0.64 cm)

Coating: (HEA) antireflecting

Pane 1 (outermost)

Name: Rendezvous window

Material: silica, 99% amorphous

Thickness: 0.7 in. (1.8 cm)

Coating: exterior – MgF_2 , interior – blue-red coating

Panes 2 and 3 (center and inner)

Name: Rendezvous window

Material: aluminosilicate glass, tempered

Thickness: 0.2 in. (0.51 cm)

Coating: (HEA) antireflecting

Pane 1 (outermost)

Name: Guidance and navigation window

Material:

Thickness:

Other:

The Apollo spacecraft had five windows as part of the spacecraft's primary pressure vessel (habitable volumes). Figure 56 shows the capsule and windows from the side. Five windows were contaminated while in orbital flight during the first three manned Apollo flights. Several reports describe the problem and its eventual solution (Blome and Upton, 1967; Kimball, 1968; Leger and Bricker, 1972). Plunkett (1970) reviewed the transmission properties of the windows.

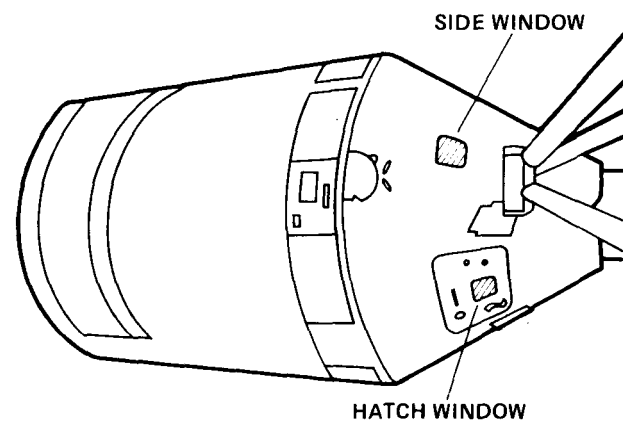

Figure 56.— Side view of the Apollo Command Module.

Pigg and Weiss (1973) point out that in addition to the nine Command Module windows and four Lunar Module windows there were many other glass instrument covers that were not part of the primary pressure vessels, "...but which sealed and protected the instruments from the spacecraft environment. The structural integrity of these windows affected crew safety and mission success to varying degrees. Windows and glass structures were not treated as a separate technology during the Apollo spacecraft design and development; therefore, consistent design philosophy and design criteria were not used initially throughout the program." Consequently, new technology had to be developed related to measuring fracture mechanics and determining analytical methods to evaluate the structural integrity of glass along with specifying a rationale for specifying proof-test requirements.

Figures 57, 58, and 59 are cross-sectional drawings of the Apollo Command Module's side, rendezvous, and hatch windows, respectively.

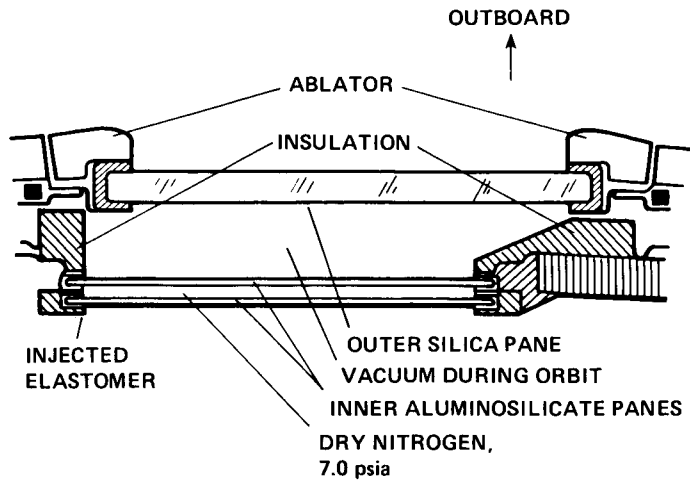

Figure 57.— Apollo Command Module side window.

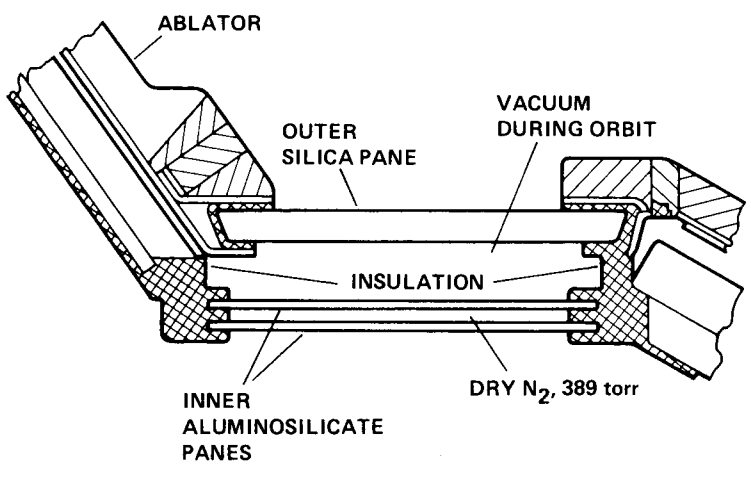

Figure 58.— Apollo Command Module rendezvous window.

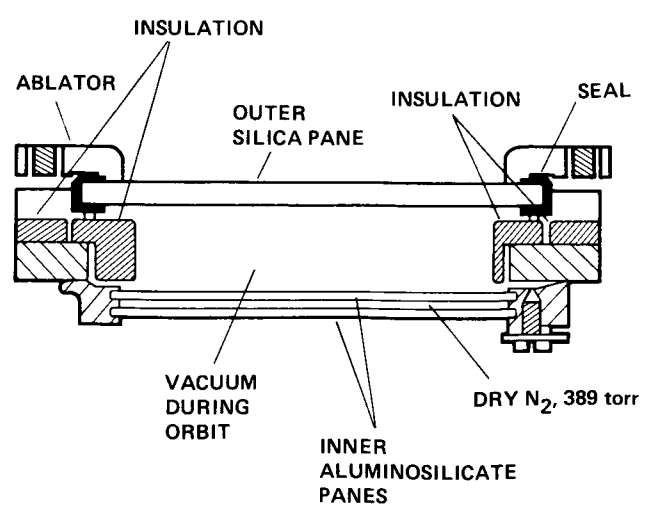

Figure 59.— Apollo Command Module hatch window.

Apollo Lunar Excursion Module

Apollo Lunar Module (Leger and Bricker, 1972; Pigg and Weiss, 1973)

Pane 1 (outermost)

Name: Forward or landing window (micrometeoroid pane)

Dimensions: 25 by 28 by 24 in. (63.5 cm by 71 cm by 61 cm) (triangular, flat surface)

Material: Corning type 7900, annealed, 96% fused silica

Thickness:

Coating: exterior – blue-red coating, interior – (HEA) antireflecting

Pane 2 (inner)

Name: Forward or landing window (pressure vessel)

Dimensions: 25 by 28 by 24 in. (63.5 cm by 71 cm by 61 cm) (triangular, flat surface)

Material: Corning type 0311, tempered, chemically strengthened

Thickness: t.b.d.

Coating: exterior – blue-red coating

Pane 1 (outermost)

Name: Docking window (micrometeoroid pane)

Dimensions: approximately 5 by 13 in. (12.7 by 33 cm) (rectangular)

Material:

Thickness:

Coating: exterior – blue-red coating, interior – (HEA) antireflecting

Pane 2 (inner)

Name: Docking window (pressure vessel)

Dimensions: approximately 5 by 13 in. (12.7 by 33 cm) (rectangular, curved surface)

Material:

Thickness:

Coating: exterior – electrically conductive coating, interior – (HEA) antireflecting

Figures 60 and 61 are cross-sectional drawings of the Apollo Lunar Excursion Module's docking window and forward window, respectively (adapted from Leger and Bricker, 1972).

Skylab

Skylab (Braly and Heaton, 1972; Gimlet and Garbaccio, 1974)

Pane 1 (single pane)

Name: Multiple docking adapter (MDA) for Experiment S-190

Dimensions: 23.3 by 17.68 in. (59 cm by 45 cm) (rectangular with rounded corners)

Material: Borosilicate, BK-7

Thickness: 1.6 in. (4 cm)

Coating: exterior – electrically conductive coating film

Pane 1

Name: Airlock, internal hatch (2 windows)

Dimensions: 8.5 in. (21.6 cm) diam

Pane 1

Name: Airlock, ECH

Dimensions:

Pane 1

Name: Wardroom window external pane (1 window)

Dimensions: Approximately 18 in. (45.7 cm) diam

Material: fused silica

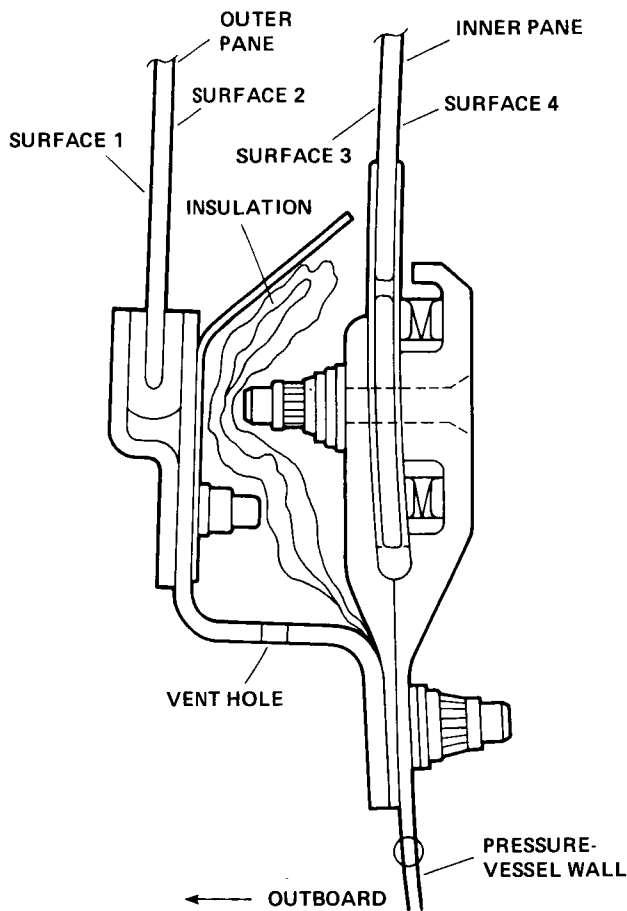

Figure 60.— Apollo Lunar Excursion Module docking window.

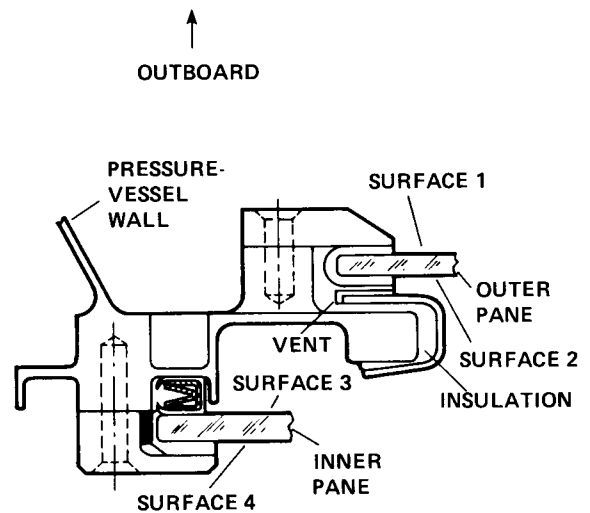

Figure 61.— Apollo Lunar Excursion Module forward window.

Thickness:

Coating:

Pane 2 (inner)

Name: Wardroom windowpane

Dimensions: approximately 18 in. (45.7 cm) diam

Material: fused silica

Thickness:

Pane 1 (outermost)

Name: Airlock, aft area of structural transition section (four windows)

Dimensions: 8 by 12 in. (20.3 by 30.5 cm) (oval)

Material: Vycor

Thickness: 0.42 in. (1 cm)

Pane 2 (inner)

Name: Airlock, aft area of structural transition section

Dimensions: 8 by 12 in (20.3 by 30.5 cm) (oval)

Material: tempered glass

Thickness: 0.24 in. (0.61 cm)

Other: pane 1 is 0.25 in. (0.64 cm) from pane 2

Pane 1 (outermost)

Name: Docking adapter window, multispectral photography experiment (one window)

Dimensions: 18 by 23 in. (45.7 by 58.4 cm) (rectangular)

Material: borosilicate

Thickness: 1.6 in. (4 cm)

Pane 1 (outermost)

Name: Docking adapter window, IR spectrometer experiment (one window)

Dimensions: 3.96 in. (10 cm) diam

Material: borosilicate crown glass

Thickness: 0.48 in. (1.2 cm)

Pane 1 (outermost)

Name: Docking adapter window, multispectral scanner experiment Window A

Dimensions: 3 in. (7.6 cm) diam

Material: fused silica

Thickness: 0.25 in. (0.64 cm)

Pane 1 (outermost)

Name: Docking adapter window, multispectral scanner experiment Window B

Dimensions: 3 in. (7.6 cm) diam

Material: Germanium glass

Thickness: 0.25 in. (0.64 cm)

The Skylab-Saturn Workshop was considered the first "Space Station" in Earth orbit because of its interior volume and amount of planning with regard to habitability. It had six windows used for experimental data acquisition, general viewing, and hand-held photography. Figure 62 shows their approximate location (NASA TM X-64814, 1974).

The wardroom window proved to be one of the most popular areas within the habitable volume. The 18-in.-diam (45.7-cm) window consisted of two panes of fused silica glass. Each was 1.03 in. (2.6 cm) thick

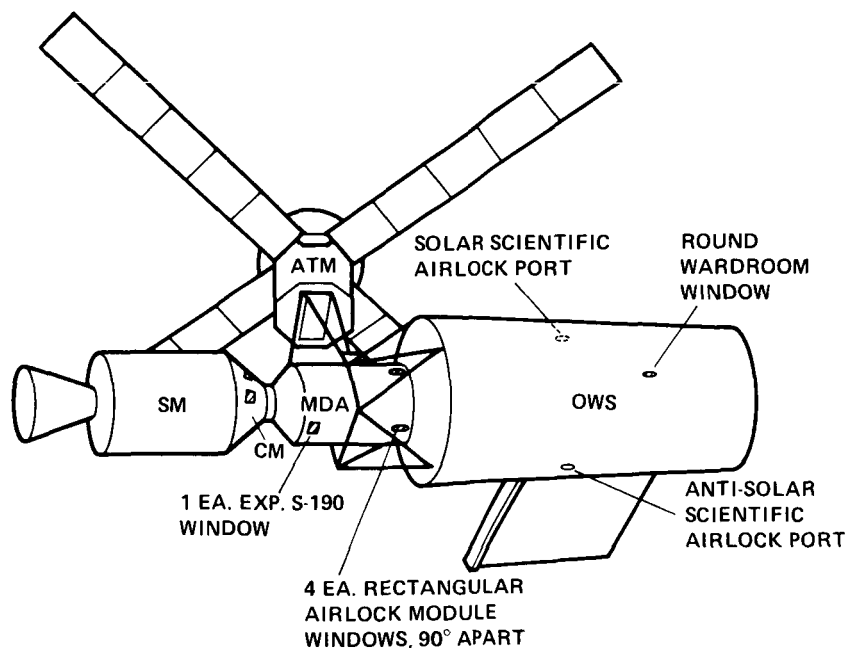

Figure 62.— Skylab-Saturn Workshop showing location of the six windows.

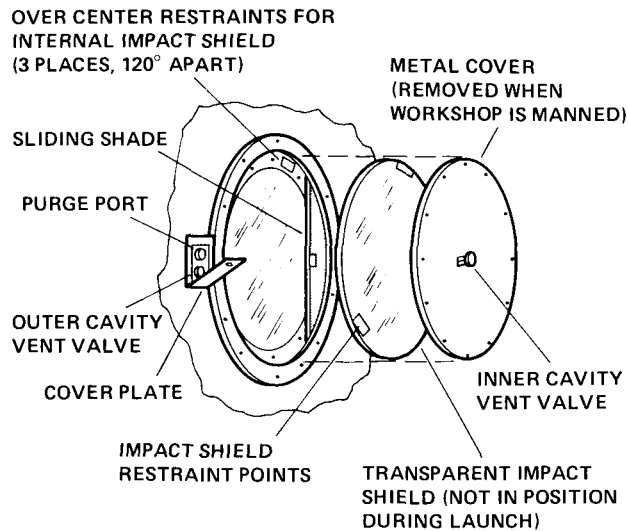

Figure 63.— Skylab spacecraft wardroom window.

and was made of schlieren-grade glass (Corning 7940). A heating unit prevented condensation on the innermost pane. In addition, a removable metal cover was provided which was removed on-orbit. A transparent protective shield also provided, as shown in figure 63 (from NASA Report TM X-64814). A sunshade could be pulled across the entire window from inside a slot. The external pane was selected so as to absorb a micrometeoroid impact of 1.06×10^{-3} g by a particle having 0.5 g/cc density traveling at 20 km/sec.

The optical transmission of the wardroom window was 65% (minimum) between 400 and 700 nm. Maximum transmission of IR radiation was 10% from 800 to 1200 nm. Transmission in the UV region of the spectrum was to be no more than 0.01% from 200 to 330 nm.

The surface of each pane had to be flat to 3 wavelengths (632.8 nm) around the (central) optical axis and each was uniform to 0.12 wavelength. The adjacent surfaces of the inner and outer panes were parallel to within 1 min arc and the total transmitted wave-front deformation was to within 0.5 wavelength over the central 18-in.-diam (45.7-cm) or 0.25 wavelength over the central 9 in. (22.9 cm) of the window.

Figure 64 shows partial sections of the wardroom window clamping assembly.

Details about the S190 experimental window located in the MDA module follow:

Braly and Heaton (1972) of Martin Marietta Corp., Denver, Colorado, found that the S190 borosilicate window could be expected to darken beyond allowable limits because of cosmic radiation bombardment

...unless additional protection was provided. The solution was to provide a radiation shield over the entire window constructed of a light honeycomb material that is swung away for limited astronaut viewing or when the S190 experiment is in operation. This shield stops the low energy electrons that damage the window's transparency.

Gimlett and Garbaccio (1974) provide technical details on the S190 Multiple Docking Adapter Window. It is made of BK 7 glass, and measures 59.18 cm X 44.91 cm X 4.06 cm. To support the multispectral photographic experiment (No. S-190), this window (on orbit) had to provide over any 7.6 cm circular area, a maximum rms deviation from the best-fitting plane of under 12 nm, and from the reference plane through the entire window, 60 nm.

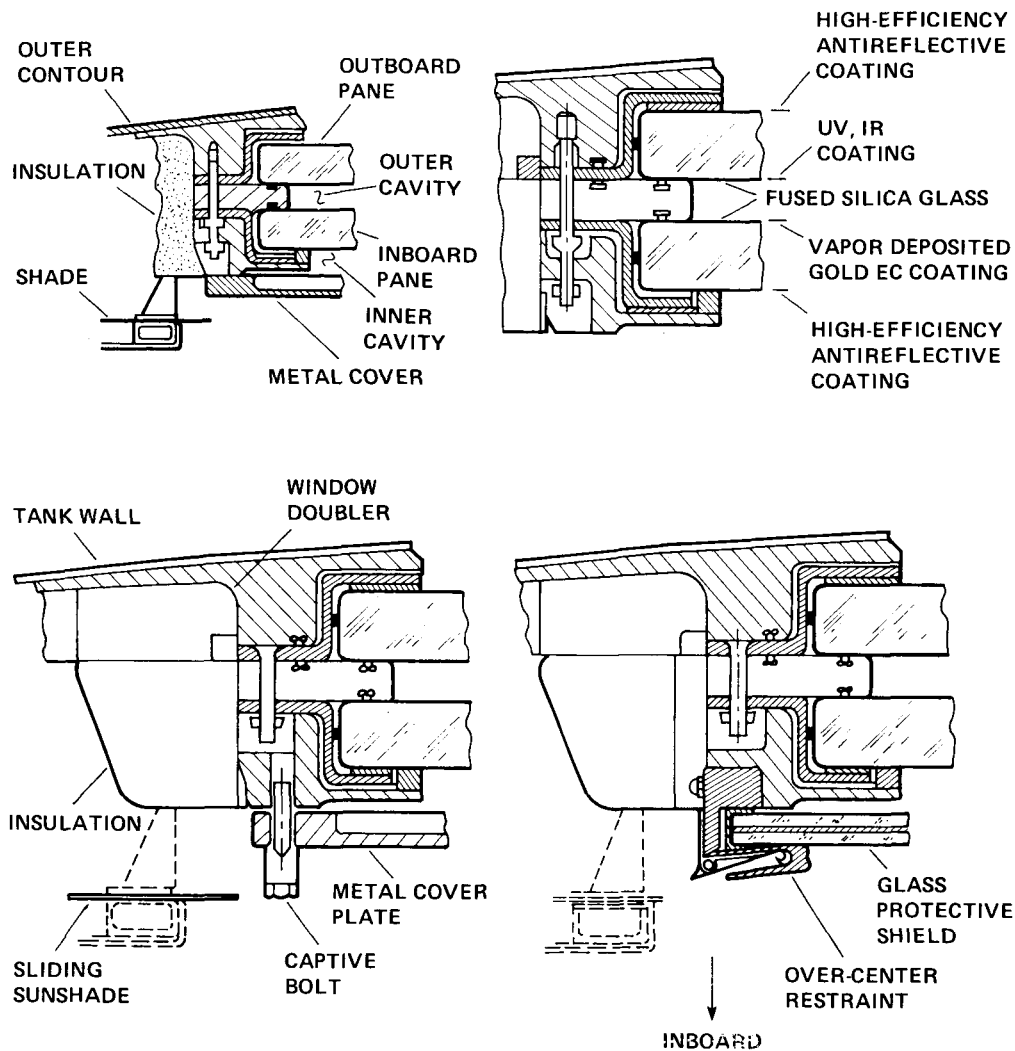

Figure 64.— Partial sections of Skylab wardroom window assembly.

The MDA window corners tend to rise in opposite direction to the applied air pressure (0.0 atm outside and 0.42 atm inside). To reduce this bending effect the corners were rounded, "...so as to approximately follow an isodeflection contour of a simply supported rectangular plate." (op cit., pg. 2629) Nevertheless, thermal deformation produced the principal contributor to optical degradation.

Figure 65 presents a partial sectional drawing of Skylab's MDA window for comparison with previous designs (from Gimlett and Garbaccio, 1974).

NASA TM X-64814 (1974, pp. 11-23) includes a photograph of the round wardroom window and various contaminations which reduced its overall usefulness.

In his review of Space Station analogues, sponsored by NASA Ames Research Center, Stuster (1984, p. 85) comments on Skylab windows as follows, "The favored leisure activity aboard Skylab was viewing the Earth from the wardroom window. The Skylab astronauts were transfixed by the sights beneath them and amazed at the clarity with which features were visible."

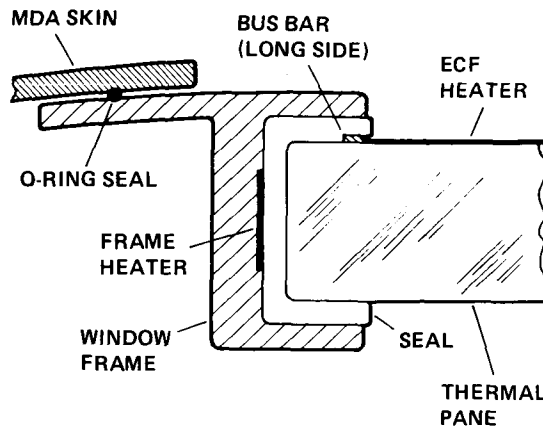

Figure 65.— Partial section of Skylab's MDA window.

Skylab astronaut Carr indicated that the first thing (he) would like to see on the Space Station is plenty of windows. "It'd be nice if each person could have a six- or eight-inch window in his quarters," he said... "But almost nothing could ease stress better. Without exception, the men who logged months aboard Skylab named the view through the station's single window as their favorite diversion" (Chaikin, 1985, p. 31).

Skylab's multispectral window is shown in figure 66(a), with the external cover and its related mechanism indicated. This window measured 18 by 23 in. and was 1.6 in. thick (46 by 58 by 4 cm), and was made of borosilicate glass. It was supported by a spring system which helped prevent vehicle distortions from producing flight loads into the glass. NASA report TM X-64814 indicated that the cover mechanism operated on-orbit for 100 cycles without any problems. The removable safety cover should also be noted.

A partial section of Skylab's multispectral window is presented in figure 66(b).

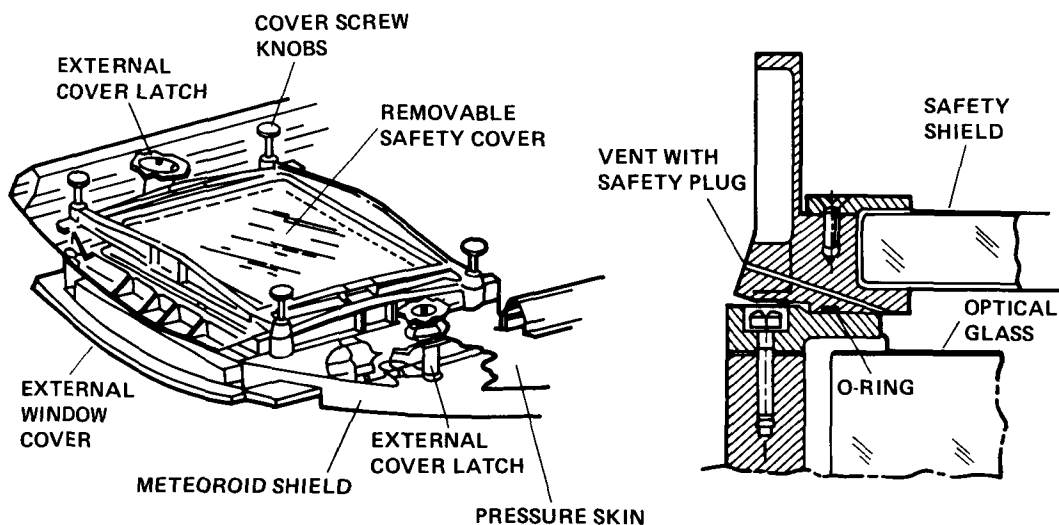

Figure 66.— Skylab multispectral window and structural details.

Space Shuttle Vehicle

Space Shuttle (Murphy, 1976)

Pane 1 (outermost)

Name: Forward cabin cockpit windows outer thermal pane (six windows)

Dimensions: various (symmetrical about centerline)

Material: fused silica

Thickness: 0.6 in to 0.7 in. (1.5 cm to 1.8 cm)

Coating: external – uncoated, internal – (HEA) antireflecting

Pane 2 (inner)

Name: Forward cabin cockpit windows, pressure pane (six windows)

Dimensions: various (symmetrical about centerline)

Material: aluminosilicate (highly tempered)

Thickness: approximately 0.7 in (1.8 cm)

Coating: external – red reflective coating, internal – (HEA) antireflecting

Pane 3 (innermost)

Name: Forward cabin cockpit windows, redundant pane (six windows)

Dimensions: various (symmetrical about centerline)

Material: fused silica

Thickness: approximately 1.4 in. (3.6 cm)

Coating: external – (HEA) antireflecting, internal – (HEA) antireflecting

Pane 1 (outermost)

Name: Aft bulkhead window (two windows)

Dimensions: 14.25 in. wide by 10.75 in. high (inboard) by 9 in. high (outboard) (36 by 27 by 23 cm)

Material:

Thickness:

Other: 3.25 in. (8.3 cm) recess into wall

Pane 1 (outermost)

Name: Aft workstation overhead window (two windows)

Dimensions: 19.75 in. by 19.75 in. (50 by 50 cm) (square) rounded corners

Material:

Thickness:

The Shuttle vehicle has six forward cockpit windows, two aft cabin overhead windows, and two aft bulkhead windows. Murphy (1976) discusses the processing of windows, level of cleanliness required, special equipment used, and various safety precautions exercised during Shuttle window handling. In addition, he presents details on spectral coatings which were used to reject IR and UV energy. He points out that the design leak rate is $<0.1 \text{ in.}^3/\text{ft of seal/min}$. Glynn and Moser (1985) discuss Orbiter's structural design systems. Figure 67 shows the left front windows with protective covers in place.

The measured spectral transmittance of the coated pressure pane, 0.7 in. (1.8 cm) thick at normal incidence, is greater than 85% between 420 and 710 nm, with sharp cutoffs outside this region (Murphy, 1976, p. 617).

A partial sectional drawing of the forward cockpit window is presented in figure 68 (from Murphy, 1976) showing the independent mounting of the outermost thermal window.

Figure 69 is a horizontal sectional drawing of the Shuttle's forward cockpit window's thermal pane abutment to the windshield post (adapted from Bell and Trotti, 1985).

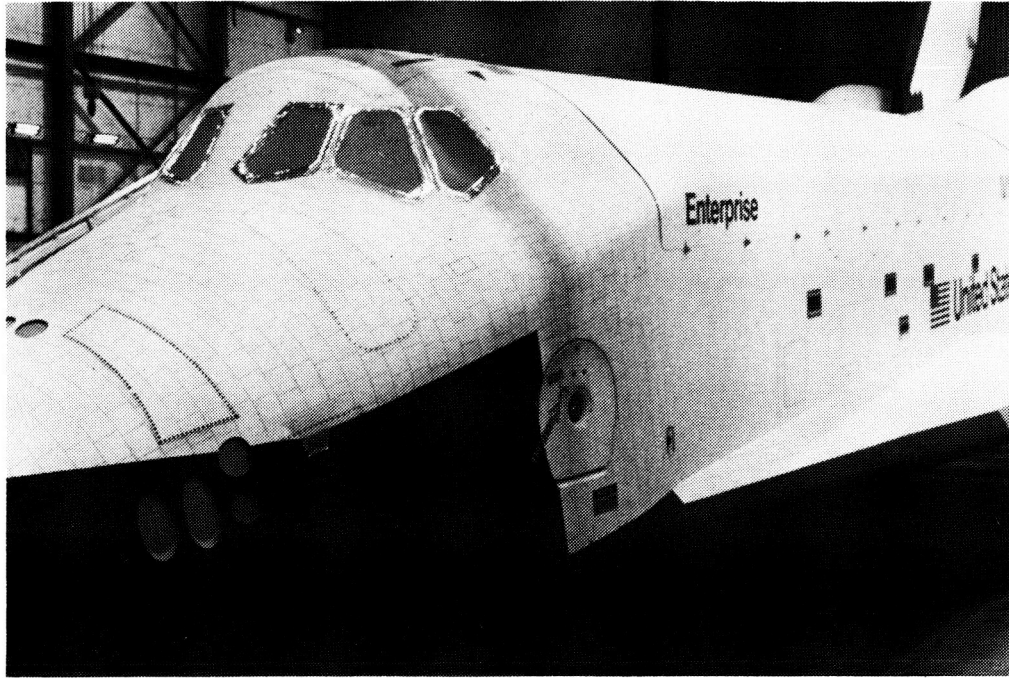

Figure 67.— Space Shuttle forward cockpit windows.

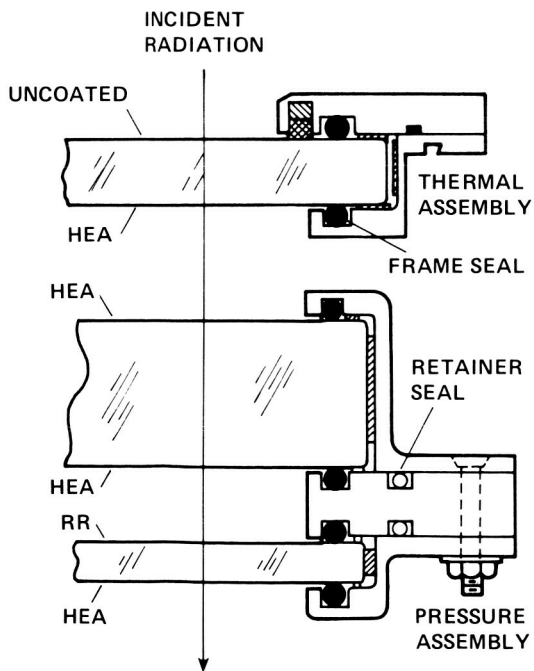

Figure 68.— Shuttle forward cockpit window.

ORIGINAL PAGE IS
OF POOR QUALITY

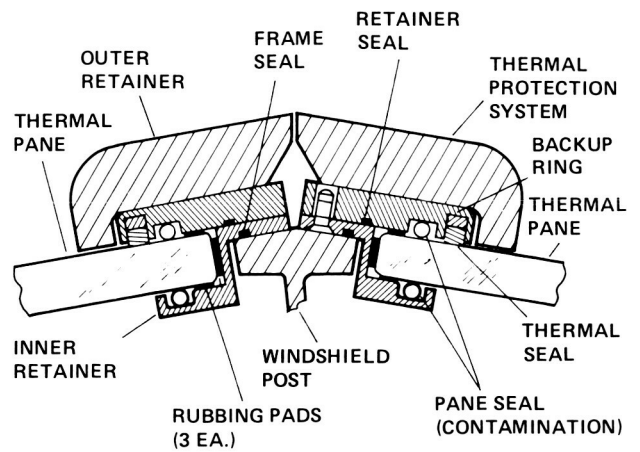

Figure 69.— Section through Shuttle forward cockpit thermal window abutment to windshield post.

**ORIGINAL PAGE IS
OF POOR QUALITY**

The aft cabin of the Shuttle was designed to permit individual and multiple viewing into the cargo bay and above the vehicle. Figure 70 shows two aft cabin overhead windows from the inside of the vehicle, and figure 71 shows these windows from outside the vehicle.

Figures 72 and 73 show an assembly drawing and partial section of the Shuttle's aft compartment bulkhead window.

The aft bulkhead windows were designed to support manual, remote manipulator system (RMS) arm control using a rotational hand controller (RHC) shown in figure 74, which is a drawing of the right half of the aft compartment looking aft.

The airlock hatch located in the Shuttle aft compartment also contains a 4-in.-diam (10-cm) window. A cross-sectional drawing of this window is shown in figure 75.



Figure 70.— Shuttle aft compartment overhead windows as seen from inside the Shuttle.

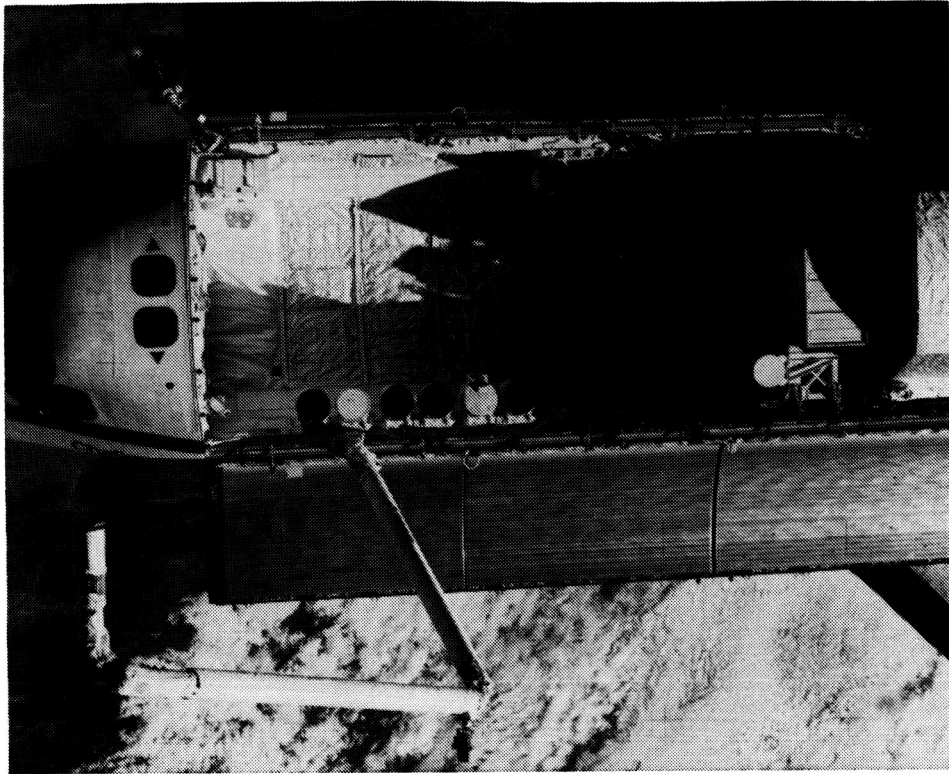

Figure 71.— Shuttle aft compartment overhead windows as seen from outside the Shuttle.

ORIGINAL PAGE IS
OF POOR QUALITY

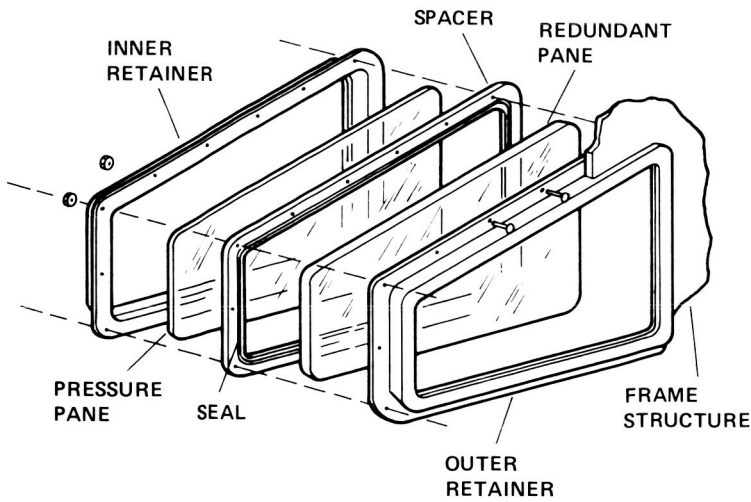

Figure 72.— Shuttle aft compartment aft bulkhead window.

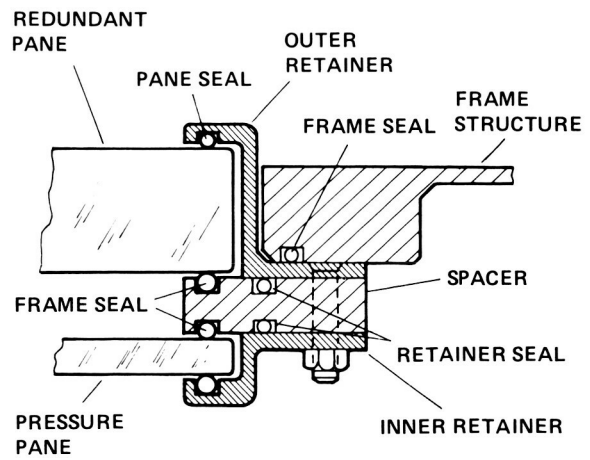

Figure 73.— Partial section of Shuttle aft compartment aft bulkhead window and clamp.

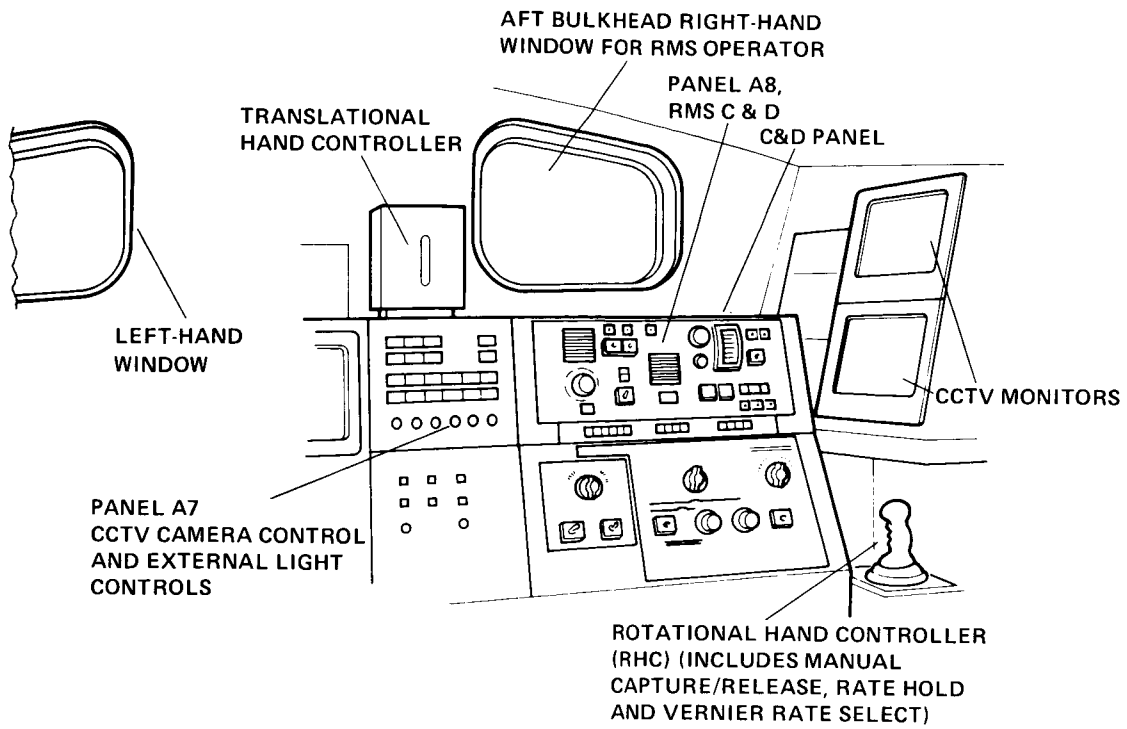

Figure 74.— Shuttle aft compartment (right half only) showing relationship of bulkhead window to displays and controls.

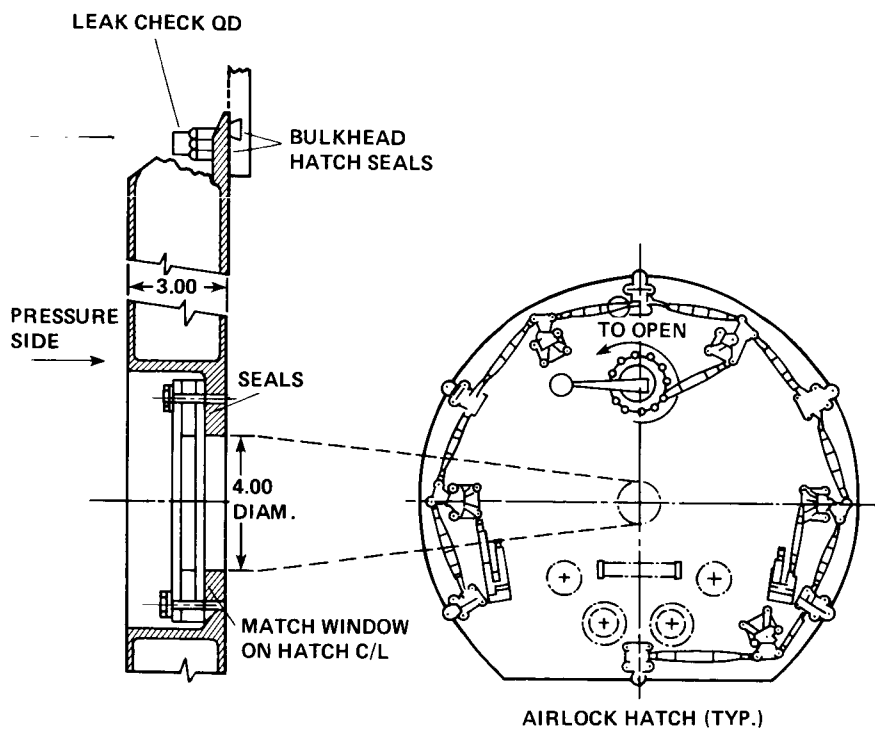

Figure 75.— Shuttle aft compartment bulkhead airlock hatch window.

European Space Agency's (ESA) Spacelab

Spacelab was designed to support a wide variety of on-orbit operations during short missions of from 7 to 30 days. Some of these activities involve general viewing of the Earth as well as optical experiments of Earth and space. Two windows were provided. The largest had a single pane and was 16.3 in. (41.4 cm) by 21.7 in. (55 cm) with mounts for fixed cameras. A mechanical cover was slid over the outer surface during periods of inactivity as was an inner thermal cover.

The second "viewport" window was 11.8 in. (30 cm) in diameter with an external cover operated from the inside and inner transparent and opaque covers. Structural integrity of the window assembly had to be maintained for a minimum of 60 min under direct solar radiation in the event the external cover malfunctioned and stayed open.

The assembled and installed viewport had a transmission of 65% or more from 400 to 700 nm. Transmission of IR radiation from 800 to 1200 nm did not exceed 10%. Transmission of UV radiation from 200 to 300 nm did not exceed 0.01%.

An electrically conductive heater film was applied to the outermost surface of the inner pane. It required 30 W total power and maintained the surface temperature above the dewpoint during extended operations with the external cover open.

Figure 76 (from unpublished ESA report SLP/2104-2) shows the Spacelab's window adapter assembly in relation to interior structure.

Figures 77(a) and (b) show the viewport window with the protective cover in the open and closed position, respectively.

A sectional drawing of Spacelab's upper pressure shell, ribs, and viewport is presented in figure 78.

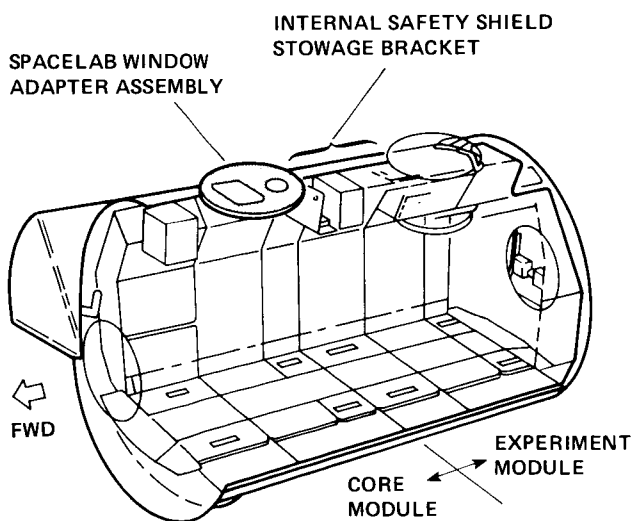

Figure 76.— Spacelab and window adapter assembly.

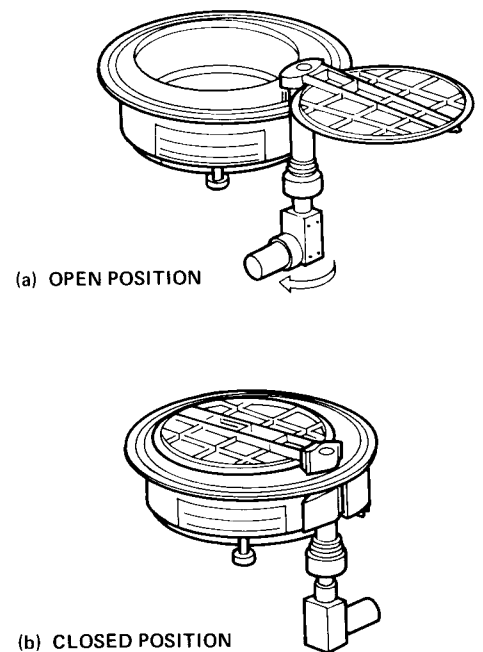

Figure 77.— Spacelab viewport external cover in open and closed positions.

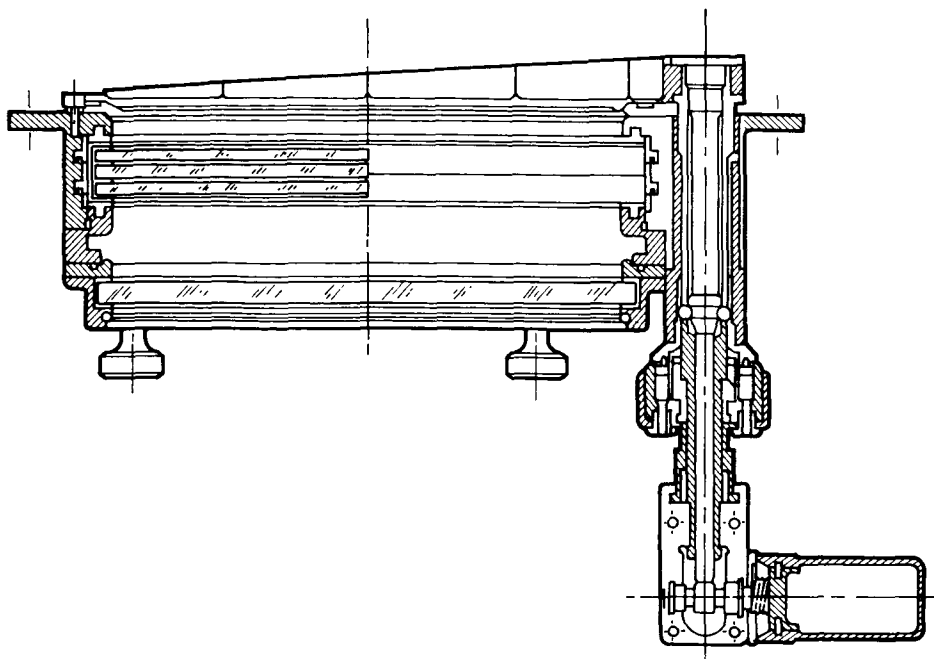

Figure 78.— Spacelab viewport assembly.

Soviet Vostok Capsule

Relatively little is known about the Vostok capsule. Three portholes have been described, one of which possessed an optical horizon scanner or “optical orientator.” Zink (1963, p. 16) remarks that, “The size of these portholes is not given, but they were large enough so that, according to Titov, the whole continent of Australia could be seen at one time. However, it is not clear whether this was the view through a single porthole or a composite view through all three.”

The optical orientator consisted of two mirror reflectors, a light filter, and a glass with a grid (reticle). This system produced an image of the horizon in the form of a ring. It is assumed that the entire 360° of the visible horizon was simultaneously visible within the system’s FOV. Thus, the point directly below the capsule would be seen centered in the circular FOV.

Figure 79 presents a drawing of the Vostok capsule showing a single round window and periscope along with other details as published in the 22 July 1965 issue of *Flight International*. Other details are reported in *Mitteilungen der DGR* (69, Nov. 1965).

Since the outer diameter of the spherical space capsule was 7 ft 5.7 in. (2.3 m), the porthole’s diameter would be about 10 in. (25.4 cm). If this drawing is approximately accurate, the setback distance is 24 in. (61 cm) for a mean FOV of 23.5° arc. The window frame on the inside of the capsule had a “quadrantal” pointer attached to it, i.e., small V-shaped pointers located at the top, bottom, and both sides facing toward the center of the window. No mention can be found for the function of these fixed pointers; however, they were probably used to aid the cosmonaut in controlling the attitude of the capsule relative to the outside scene.

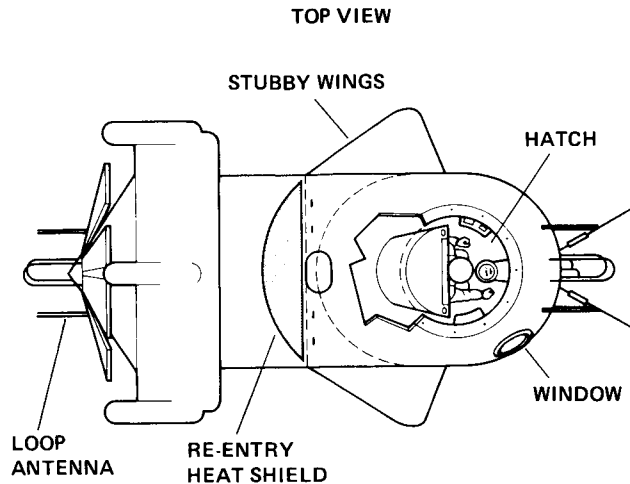

Figure 79.— Soviet Vostok capsule.

Soviet Soyuz Capsule

In a photograph showing an external view of the Soyuz training simulator capsule located at Zvezdnoy Gorodok, U.S.S.R. Col. Valery F. Bykovsky and Vladimir Aksenov are shown as well, giving the round window behind them an approximate scale. Again, the diameter of the window is about 10 in. (25.4 cm).

Soviet Salyut 6 and 7 Vehicles

According to B. J. Bluth and M. Helppie (Soviet Space Stations as Analogs, 2nd Ed., NAGW-659, Aug. 1986, unpublished report), there are approximately 20 windows on the Soviet space station Salyut 7. Each window is made of two 0.55-in.-thick (1.4 cm) panes of quartz glass. They are hermetically attached to the flanges on a cylindrical ring. Dry air fills the space between the two panes. The inside of each window is provided with a piece of thick, removable glass and the outsides of some windows have transparent covers. My investigation shows that all windows on Soviet spacecraft have been round. (See Beliaev et al. (1979) and Zakharov et al. (1979) for information on the Salyut 4 windows.)

The windows on Salyut 6 experienced several problems which included a gradual loss of transparency and an increase in the number of scratches; tiny craters as deep as 0.15 in. (4 mm) caused by micrometeorites (Bluth and Helppie, unpublished report, 1986); external surface contamination by engine by-products; and internal surface contamination by (unspecified) particles and dust.

As a result of an analysis of problems experienced on Salyut 6, several changes were made on Salyut 7. They included adding a thick, removable glass to the inside of the windows which could be removed when precise observations had to be made, adding electrically controlled transparent outer covers which were kept closed most of the time, and adding two windows which were "transparent to ultraviolet light." This was done to (1) "enlarge the station's investigative arsenal," (2) protect against the possibility of the development of pathogenic bacteria carried along from Earth, (3) permit certain astronomical studies, and (4) allow the cosmonauts to get a tan. These two special portholes are located in a passageway and in the main compartment. Cosmonaut Lebedev is quoted in this regard, "It is possible to get tanned....Since there is no atmosphere, two minutes under its rays (sun rays) produce the same effect as a day on the beach."

ORIGINAL PAGE IS
OF POOR QUALITY

Still cited as an unresolved problem on Salyut 7 was a decrease in transparency over time because of the breakdown of the external heat-control coating. Apparently the Soviets tried to apply a removable transparent material to the outside of a window. Bluth and Helppie (unpublished report, 1986) points out that during one EVA, "The cosmonauts were asked to remove a sample, but they could not do it."

Figure 80 shows an external view of one of Salyut's small windows set well back into the sewn thermal blanket which enveloped the vehicle. The diameter of clear glass was approximately 10 in. (25.4 cm). The setback thickness of the thermal blanket was about 6 in. (15.2 cm) and tapered to afford a somewhat wider FOV than otherwise.

Figure 81 shows a vertical section drawing of Salyut with the double-pane windows shown in cross section in the upper third of the drawing. Both panes appear to be of equal thickness and to be separated by the thickness of a single pane. The overall thinness of the adjacent wall structure would permit a short setback distance for an estimated maximum FOV of perhaps 130° to 140°.

Figure 82 presents a down-looking plan view of Salyut showing the windows in relation to other interior detail.



Figure 80.— Soviet Salyut spacecraft window (lower left). (Photograph furnished by Aviation Week & Space Technology — used by permission).

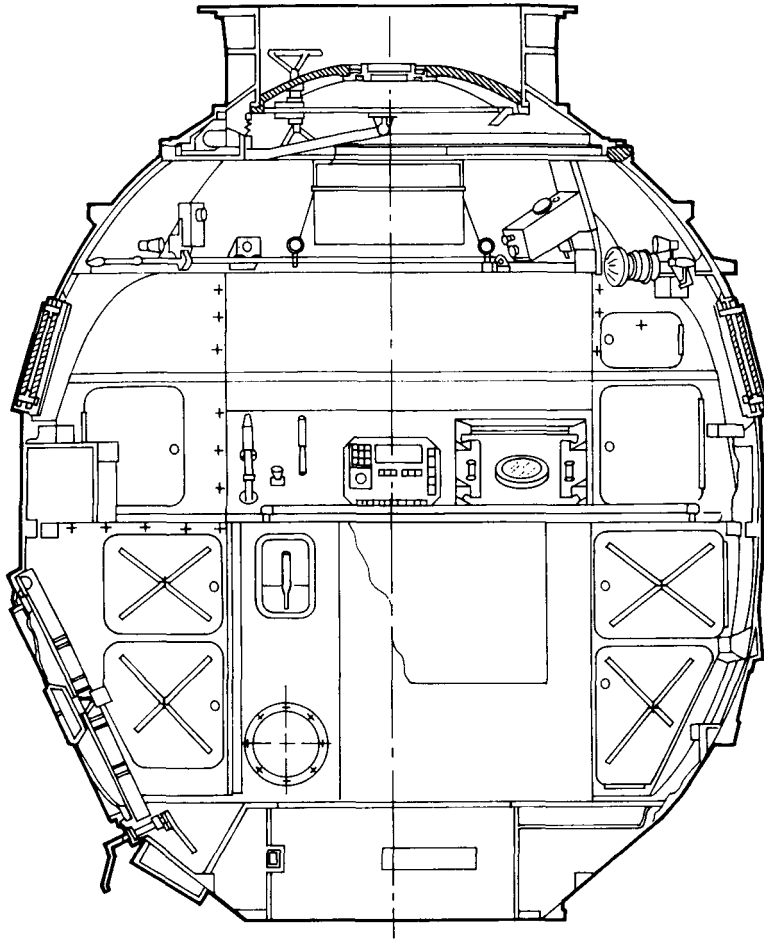

Figure 81.— Soviet Salyut spacecraft (vertical section). (Furnished by Aviation Week & Space Technology — used by permission.)

Figure 83 shows the cosmonauts inside the Salyut Spacecraft with the round window seen on the center right. During his 211-day-long flight on Salyut 7, cosmonaut Lebedev wrote in his diary, “It’s getting increasingly difficult. Only the visual observations have a relaxing effect” (Bluth and Helppie, unpublished report, 1985). Another diary entry was, “We just like sitting at portholes....We watch things down on the Earth....” On May 14, 1982, one day into the flight, Lebedev wrote concerning his fellow cosmonaut that “Every chance he gets, Tolya looks out the window: ‘Look, Valya!’ And my answer: ‘All right, all right, we have six months to look at it.’ Still another post-flight comment made was that windows...provided the opportunity to take a breather from our work and relate one-on-one with the Earth.”

This review of prior and current Soviet spacecraft has shown that most, if not all, windows have been round, about 10 in. (25.4 cm) in diameter, double-paned, and of flat, parallel-surface glass.

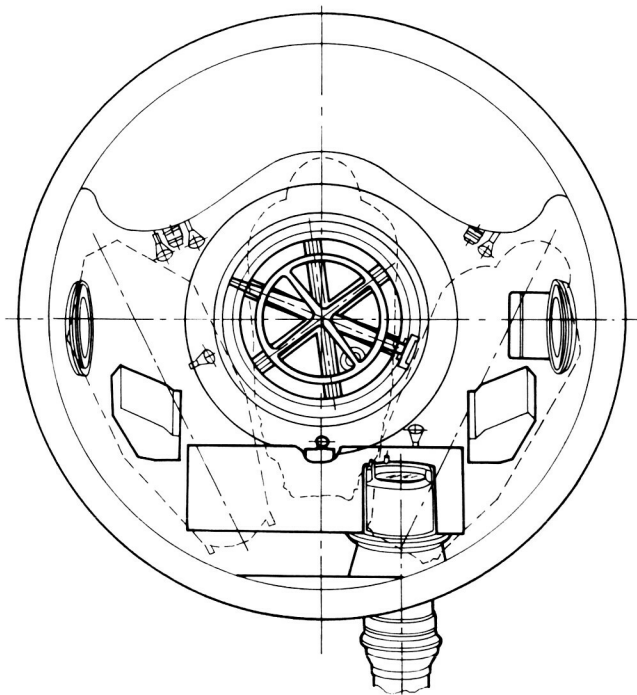

Figure 82.— Soviet Salyut spacecraft plan view. (Furnished by Aviation Week & Space Technology — used by permission.)

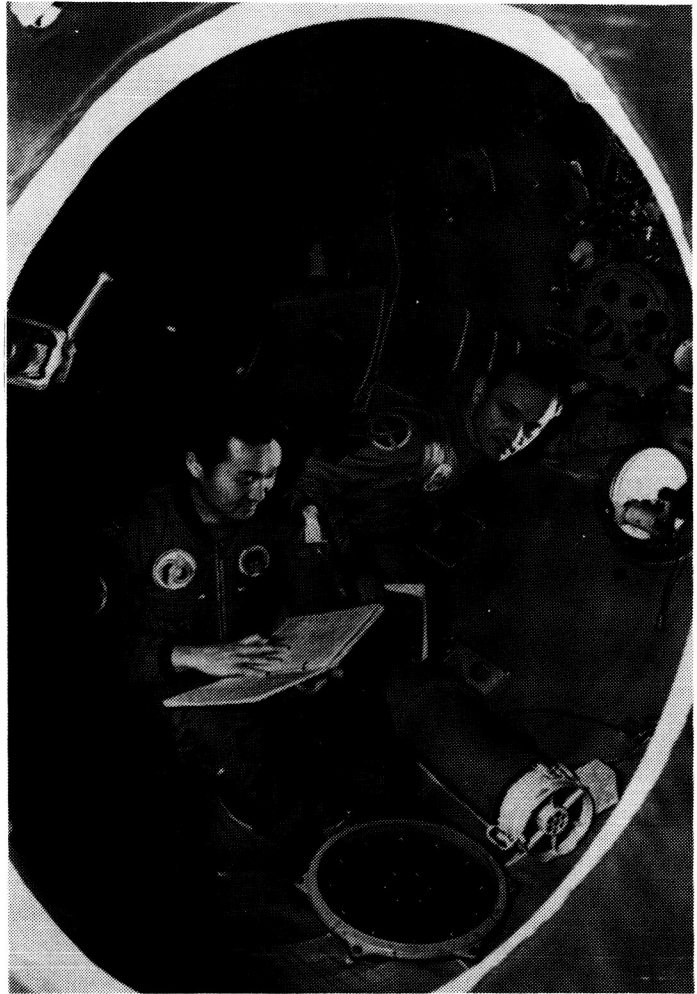

Figure 83.— Soviet cosmonauts on Salyut with a round window visible on the right. (Furnished by Aviation Week & Space Technology — used by permission.)

REFERENCES

- Air Force Systems Command: AFSC Design Handbook, Human Factors Engineering, Third ed., Rev. 1, Andrews AFB, July 1984.
- Allen, C. W.: Astrophysical Quantities. Second ed. The Athlone Press (London), 1963.
- Alpern, M.; Thompson, S.; and Lee, M. S.: Spectral Transmittance of Visible Light by the Living Human Eye. *J. Opt. Soc. Amer.*, vol. 55, no. 6, June 1965, pp. 723-727.
- Arduini, C.: Thermal Control of Transparent Elements Onboard Artificial Satellites. NASA CR-101131, 1968.
- Bartley, S. H.: Principles of Perception. Harper, 1958.
- Bartley, S. H.: The Psychophysiology of Vision, Ch. 24 in Handbook of Experimental Psychology, S. S. Stevens, ed., John Wiley & Sons, Inc., 1962, pp. 921-948.
- Battelle Memorial Institute: Radiation Effects on Glass, An Annotated Bibliography, by B. A. Gilmore and W. F. Heenan. Memorandum 26, BMI, Columbus, Ohio, Sept. 15, 1965.
- Bechmann, R.: Radiation Effects in Quartz, a Bibliography. *Nucleonics*, vol. 16, no. 3, 1958, p. 122.
- Beliaev, B. I.; Grechko, G. M.; Gubarev, A. A.; Kiselevskii, L. I.; Klimuk, P. I.; Pliuta, V. E.; and Sevastianov, V. I.: Investigation of the Optical Characteristics of Spacecraft Windows—for Earth-Surface Spectral Recordings. Investigation of Atmospheric-Optics Phenomena From the Salyut-4 Orbital Station. (A80-42558 18-46) Tartu, Akademiia Nauk Estonskoi SSR, Institut Astrofiziki i Fiziki Atmosfery, 1979, pp. 103-114. In Russian.
- Bell, L.; Trotti, G.; Hua, L.; Brown, J.; Winisdoerffer, F.; and Ximenes, S.: Space Station Viewport Study. Lyndon B. Johnson Space Center, JSC 32003, Dec. 1985.
- Blome, J. C.; and Upton, B. E.: Gemini Window Contamination Due To Outgassing of Silicones. Proc. 11th Nat. Symp. and Exhibit, Soc. Aero. Mat. Proc. Eng., Sci. of Adv. Mat. and Process Eng. Series, vol. 11, 1967, pp. 217-225.
- Bolstad, L.; Crook, T.; Loy, J.; and Gonnella, N.: Gassing and Flammability Testing of Organic Materials for Apollo C/M Stabilization and Control System. Doc. No. A63777-A22020, Honeywell, Sept. 1963.
- Bonner, G. P.; Heidt, M. F.; Kotila, C. L.; Lintott, J. A.; and Novotny, J. E.: Postflight Optical Evaluation of the Right-Hand and Left-Hand Windows of Gemini Missions IV, V, VI, and VII. NASA TN D-4916, 1968.
- Bonner, G. P.; Heidt, M. F.; Kotila, C. L.; Lintott, J. A.; Novotny, J. E.; Shafer, J. W.; and Stokes, R. C.: Preflight Optical Evaluation of the Right-Hand Hatch Windows of Gemini Missions VII, VIII, IX, and XII. NASA TN D-5471, 1969.
- Bradley, O. H., Jr.: Development of a Window Protection Assembly for a Shuttle Experiment. Proc. 15th Aerospace Mech. Symp., NASA CR 2181, 1981, pp. 303-329.
- Braly, J. E.; and Heaton, T. R.: Radiation Problems Associated with Skylab. In NASA, Washington Proc. Natl. Symp. on Nat. and Manmade Radiation in Space, W. A. Warman, ed. (see N72 17601 08-22), Martin Marietta Corp., Denver, Jan. 1972, pp. 748-755. (Also pub. as NASA TM X-2440, 1972.)
- Brissenden, R. F.: Angular Motion Deflection by Human Pilots and Application to Space Rendezvous Control. NASA TN D-1498, 1962.
- Brissenden, R. F.; and Lineberry, E. C., Jr.: Visual Control of Rendezvous. 30th Ann. Meeting Inst. Aerospace Sci., New York, January 22-24, 1962.

- Brown, D. R. E.: Natural Illumination Charts. Report No. 374-1, U.S. Navy Bureau of Ships, 1952.
- Brown, J. F.: Uber gesehene Geschwindigkeit. Psychol. Forsch., vol. 10, 1927, pp. 84-101.
- Brown, J. F.: Thresholds for Visual Movement. Psychol. Forsch., vol. 14, 1931, pp. 249-268.
- Brown, J. L.: Experimental Investigations of Flash Blindness. Human Factors, vol. 6, no. 5, Oct. 1964, pp. 503-516.
- Campanile, R.: Tests of Sealing Methods. NASA CR-125232, 1965.
- Campanile, R.; and Rudes, F.: Results of Screening Tests of Lem Window Materials. NASA CR-65777, 1963.
- Carpenter, M. S.; Cooper, L. G.; Glen, J. H., Jr.; Grissom, V. I.; Schirra, W. M., Jr.; Shepard, A. B., Jr.; and Slayton, D. K.: We Seven. Simon & Schuster, 1962.
- Cartwright, D.: On Visual Speed. Psychol. Forsch., vol. 22, 1938, pp. 320-342.
- Chaikin, A.: The Loneliness of the Long-Distance Astronaut. Discover, vol. 6, no. 2, Feb. 1985, pp. 20-31.
- Chorvinsky, M.; Herman, J. R.; McMinn, W. O.; and Strano, J. S.: Optical Phenomena in Space. U.S. Air Force, Rome Air Development Center, Griffiss AFB, N.Y., RADC-TR-61-163, July 1961.
- Cibis, P. A.; and Haber, F.: Studies on Effects of Windshields and/or Air of Different Densities in Stereoscopic Vision. School of Aviation Med., Randolph Field, Texas, Nov. 1950.
- Clanton, U. S.; Zook, H. A.; and Schultz, R. A.: Hypervelocity Impacts on Skylab IV/Apollo Windows. Proc. 11th Lunar and Planetary Sci. Conf., Houston, March 17-21, 1980, vol. 3, Pergamon Press, 1980, pp. 2261-2273.
- Comstock, M.; and Ferrigaro, P.: Effects of Radiation on Glass, a Bibliography. BNL 6513, Brookhaven National Labs, Upton, N.Y., 1962.
- Cornsweet, T. N.: Changes in the Appearance of Stimuli of Very High Luminance. Psych. Rev., vol. 69, no. 4, July 1962, pp. 257-273.
- Cour-Palais, B. G.: Apollo Window Meteoroid Experiment. NASA SP-330, 1973, pp. 21-1 to 21-9.
- Cour-Palais, B. G.: Results of the Examination of the Skylab/Apollo Windows for Micrometeoroid Impacts. Proc. 10th Lunar Planet. Sci. Conf., Houston, March 19-23, 1979, pp. 1665-1672.
- Cour-Palais, B. G.; Flaherty, R. E.; and Brown, M. L.: Apollo Window Meteoroid Experiment. NASA SP-289, 1972(b), pp. 24-1 to 24-9.
- Cour-Palais, B. G.; Brown, M. L.; and McKay, D. S.: Apollo Window Meteoroid Experiment. NASA SP-315, 1972(a), pp. 26-1 to 26-10.
- Craik, K. J. W.; and Vernon, M. D.: The Nature of Dark Adaptation, Pt. I, Evidence as to the Locus of the process, British J. Psych., vol. 32, 1941-42, pp. 62-81.
- Crook, D. J.; Hanson, J. A.; McBride, P. L.; and Wulfeck, J. W.: A Bibliography on Dark Adaptation. 33rd Meeting, Armed Forces-NRC Vision Committee, Fort Knox, Ky., Nov. 12-13, 1953, pp. 131-161.
- Department of Transportation: Cockpit Vision and Cockpit Controls, 37 F.R. 23574, Nov. 4, 1972.
- Donahoo, M. E.; and Anderson, C. C.: Shuttle Program, Space Station Operations. Vol. 3, Proximity Operations, Lyndon B. Johnson Space Center, NASA Report 83-FM-50 (JSC-19371), Feb. 1985.

- Duncker, K.: *Über induzierte Bewegung. Ein Beitrag zur Theorie optisch Wahrgenommener Bewegung.* Psychol. Forsch., vol. 12, 1929, pp. 180-259.
- Eardley, C. J.: *CSM Meteoroid Reliability Study Probability of Crew Safety for 56-Day Skylab Mission.* NASA CR-140237, 1970.
- Eardley, C. J.; and Smith, S. M.: *Meteoroid Hazard Analysis of Skylab Windows.* NASA CR-140236, 1972.
- Ferree, C. E.; and Rand, G.: *Further Studies on the Extent and Shape of the Color Fields in Relation to the Intensity of the Stimulus Light.* Amer. J. Physiol. Opt., vol. 5, no. 4, Oct. 1924, pp. 409-419.
- Fleagle, R. G.; and Businger, J. A.: *An Introduction to Atmospheric Physics.* Second ed., Academic Press, 1980.
- Frank, N. H.: *Introduction to Electricity and Optics.* Second ed., McGraw-Hill Book Co., Inc., 1950.
- Freeman, R. D.: *Alignment Detection and Resolution as a Function of Retinal Location.* Amer. J. Optom., vol. 43, no. 12, 1966, pp. 812-817.
- Fritz, S.: *Solar Radiant Energy and Its Modification by the Earth and Its Atmosphere.* Compendium of Meteorology, T. F. Malone, Boston, Amer. Meteorol. Soc., 1951, p. 13.
- Gadeberg, B. L.; and White, K. C.: *Description of an Analytic Method for the Determination of Spacecraft Window-Induced Navigation Sighting Errors.* NASA TM X-61075, 1968.
- Gimlett, J. I.; and Garbaccio, D. H.: *Multiple Docking Adapter Window for the S-190 Experiment.* Appl. Opt., vol. 13, no. 11, Nov. 1974, pp. 2629-2637.
- Glynn, P. C.; and Moser, T. L.: *Orbiter Structural Design and Verification.* Space Shuttle Tech. Conf., Pt. 1, Lyndon B. Johnson Space Center, Jan. 1985, pp. 345-356.
- Griffin, B. N.: *Design Guide: The Influence of Zero-g and Acceleration on the Human Factors of Spacecraft Design.* Lyndon B. Johnson Space Center, JSC 14581, Aug. 1978.
- Griffin, D. R.; Hubbard, R.; and Wald, G.: *The Sensitivity of the Human Eye to Infrared Radiation.* J. Opt. Soc. Amer., vol. 37, no. 7, July 1947, pp. 546-554.
- Haines, R. F.: *Size Matching Accuracy Under Very High Target Luminances.* Preprints of Scientific Program, 1967 Ann. Aerospace Med. Assoc. Meeting, April 10-13, 1967, Washington, pp. 278-279.
- Haines, R. F.: *Detection Time to a Point Source of Light Appearing on a Star Field Background With and Without a Glare Source Present.* Human Factors, vol. 10, no. 5, Oct. 1968, pp. 523-529.
- Haines, R. F.: *A Review of Peripheral Vision Capabilities for Display Layout Designers.* Proc. Soc. Inform. Display, vol. 16, no. 4, 1975, pp. 238-249.
- Haines, R. F.: *Cockpit Window Edge Proximity Effects on Judgements of Horizon Vertical Displacement.* Proc. 20th Ann. Conf. Manual Contr., vol. 1, NASA CP-2341, 1984, pp. 491-514.
- Haines, R. F.: *A Preliminary Human Factors Planning and Design Outline of Parameters Related to Space Station Windows and CCTV Monitoring.* Proc. Seminar on Space Station Human Productivity, NASA TM-86673, 1985, pp. 4-28 to 4-59.
- Haines, R. F.; and Bartley, S. H.: *A Study of Certain Visual Effects Occasioned by Factors of So-Called Glare.* J. Psych., vol. 62, March 1966, pp. 255-266.

- Haines, R. F.; and Gilliland, K.: Response Time in the Full Visual Field. *J. Appl. Psych.*, vol. 58, no. 3, Dec. 1973, pp. 289-295.
- Haines, R. F.; Dawson, L. M.; Galvan, T.; and Reid, L. M.: Response Time to Colored Stimuli in the Full Visual Field. NASA TN D-7927, 1975.
- Hardy, A. C.: Atmospheric Limitations on the Performance of Telescopes. *J. Opt. Soc. Amer.*, vol. 36, no. 5, May 1946, pp. 283-287.
- Harris, R. J.; and Reeck, E.: Hypervelocity Impact Testing of Glass Materials. NASA CR-118937, 1963.
- Hass, G.; and Hunter, W. R.: Laboratory Experiments to Study Surface Contamination and Degradation of Optical Coatings and Materials in Simulated Space Environments. *Appl. Opt.*, vol. 9, no. 9, Sept. 1970, pp. 2101-2110.
- Hecht, S.; and Hsia, Y.: Dark Adaptation Following Light Adaptation to Red and White Lights. *J. Opt. Soc. Amer.*, vol. 35, no. 4, April 1945, pp. 261-267.
- Heinisch, R. P.: Light Scatter From Contaminated Spacecraft Windows. AIAA Paper 71-472, April 1971.
- Heinisch, R. P.; Jolliffe, C. L.; and Schmidt, R. N.: An Experimental and Analytical Study of Visual Detection in a Spacecraft Environment, 1 July 1968-1 July 1969, NASA CR-1561, 1970.
- Heinisch, R. P.; and Schmidt, R. N.: Study of Astronaut's Ability to Detect Stars Through a Contaminated Spacecraft Window. NASA CR-73445, May 1970.
- Holly, F. F.; and Rogers, V. R.: Direct and Neighboring Sensitivity Changes Produced by Red and Blue-White Adapting Fields. USARL Report 82-1, U.S. Army Aeromedical Research Laboratory, Fort Rucker, 1981.
- Hyle, C. T.; and Lunde, A. N.: The Earth and the Moon as Viewed From the Spacecraft During Apollo 8 Mission. NASA TM X-69681, 1968.
- Hyman, A.: Utilizing the Visual Environment in Space. *Human Factors*, vol. 5, no. 3, June 1963, pp. 175-186.
- Irvine, C. N.: *Development of Space Station Window Assemblies*. NASA TM X-53853, 1969.
- Illuminating Engineering Society of North America: *Illuminating Engineering Nomenclature and Photometric Standards—American Standard*. Illum. Engr. Soc. of Amer., New York, 1942.
- Jackson, J.; Bond, R.; and Gundersen, R.: Man-Machine Engineering Data Applications of Skylab Experiments M487 and M516, Skylab Experience Bulletin no. 17, Neutral Body Posture in Zero-g. NASA TM-85543 (also JSC-09551), 1975.
- Jensen, J.; Townsend, G.; Kork, J.; and Kraft, D.: *Design Guide to Orbital Flight*. McGraw-Hill Book Co., Inc., 1962.
- Johnson, F. S.: The Solar Constant. *J. Meteorol.*, vol. 11, no. 6, Dec. 1954, pp. 431-439.
- Jones, E. R.; and Hann, W. H., Jr.: Vision and the Mercury Capsule. Paper presented at the annual meeting of the Armed Forces-NRC Committee on Vision, Washington, March 30-31, 1961.
- Jones, R. L.: An Investigation of Earthshine Lighting Conditions for Lunar-Surface Operations. NASA TM X-58011, 1967.
- Kelley, D. M.: Study of the Effect of Spacecraft Window Configuration on Lines of Sight. NASA CR-114310, 1971, p. 142.
- Kerr, J. L.: Visual Resolution in the Periphery. *Percept. Psychophys.*, vol. 9, issue 3B, March 1971, pp. 375-378.

- Kessler, D. J.: Sources of Orbital Debris and the Projected Environment for Future Spacecraft. *J. Spacecraft Rockets*, vol. 18, no. 4, July-Aug. 1981, pp. 357-360.
- Kessler, D. J.; and Cour-Palais, B. G.: Collision Frequency of Artificial Satellites: The Creation of a Debris Belt. *J. Geophys. Res.*, vol. 83, no. A6, June 1978, pp. 2637-2646.
- Kimball, L. G.: Postflight Investigation of Apollo Command Module 101 Windows. Report NA-68-922, North American Rockwell, Los Angeles Div., Dec. 1968.
- Koval, I. K.: On the Study of the Optical Properties of the Atmosphere and Surface of Mars. *Physics of the Moon and Planets*, I. K. Koval, ed., Kiev, USSR: Naukova Dumka. NASA TT-F-382, 1966, pp. 34-39.
- Lamar, E. S.; Hecht, S.; Shlaer, S.; and Hendley, C. D.: Size, Shape, and Contrast in Detection of Targets by Daylight Vision. I. Data and Analytical Description. *J. Opt. Soc. Amer.*, vol. 37, no. 7, July 1947, pp. 531-543.
- Leger, L. J.; and Bricker, R. W.: Apollo Experience Report—Window Contamination. NASA TN D-6721, 1972.
- Legge, G. E.; and Campell, F. W.: Displacement Detection in Human Vision. *Vision Res.*, vol. 21, no. 2, 1981, pp. 205-213.
- Lina, L. J.; and Assadourian, A.: Investigation of the Visual Boundary for Immediate Perception of Vertical Rate of Descent. NASA TN D-1591, 1963.
- List, R. J.: *Smithsonian Meteorological Tables*, Sixth ed., Washington, 1963.
- Low, F. N.: The Development of Peripheral Visual Acuity During the Process of Dark Adaptation. *Amer. J. Physiol.*, vol. 146, no. 4, July 1946, pp. 622-629.
- Lszarev, A. I.; and Daminova, T. A.: On the Influence of Atmosphere and the Observation Window of a Spacecraft on the Contrasts of Natural Formations Visible From Space. Joint Publications Research Service, Arlington, Va. In its USSR Rept.: Space (JPRS-L/9526) pp. 40-49. Transl. from *Issled. Zemli iz Kosmosa (Moscow)*, no. 5, Sept.-Oct. 1980, pp. 64-70.
- Lyndon B. Johnson Space Flight Center: Space Station Reference Configuration Description. NASA TM-87493 (also JSC-19989), 1984.
- Lyndon B. Johnson Space Center: Zero-g Workstation Design. NASA TM-80000 (also JSC Internal Note 76-EW-1), 1976, pp. 107-127.
- Marshall Space Flight Center: Skylab Mission Report—Saturn Workshop. NASA TM X-64814, 1974, pp. 4-3 to 4-6 and 11-20 to 11-23.
- McCanless, F.; Quasius, G.; and Unruh, W.: Systems and Signal Processing Analyses of Star Trackers in Aerospace Navigation and Guidance. ASD-TDR-62-1056, Minneapolis Honeywell Regulator Co., Military Products Group, Aeronautical Div., St. Petersburg, Fla., Tech. Doc. Rept., Jan. 20, 1963.
- McPherson, D. G.: Apollo Telescope Mount Extended Applications Study Program—ATM Contamination Study. NASA CR-61173, 1967.
- Mechtly, E. A.: *The International System of Units: Physical Constants and Conversion Factors*. NASA SP-7012, 1964.
- Miller, N. D.: Visual Recovery. Tech. Doc. Rep. 2, USAF School of Aerospace Medicine, Brooks AFB, Tex., SAM-TR-65-12, 1965.
- Muraca, R. F.; and Whittick, J. S.: *Polymers for Spacecraft Applications*. NASA CR-89557, 1967.

- Murphy, J. K.: The Challenge of Coating and Assembling Space Shuttle Windows. USAF, Wright-Patterson AFB, Rept. AD-B053228L, April 1976.
- Murtagh, T. B.; Price, C. R.; and Smith, H. E.: Analysis of Gemini 7 Star Sightings Utilizing a Space Sextant in Gemini 6. *J. Spacecraft Rockets*, vol. 4, no. 5, May 1967, pp. 567-572.
- Muscari, J. A.; Jambor, B. J.; and Wescott, P. A.: Preliminary Results Skylab Experiment T027 Optical Contamination in Space. *Proc. Intern. Conf. Evaluation of the Effect of the Space Environment on Materials*. Toulouse, France, June 17-21, 1974, pp. 297-315.
- Neu, J. T.; Philbin, E. J.; Mahadevan, P.; and Compton, J.: Evaluation of the Effects of Space Environment Exposure on Index of Refraction and Extinction Coefficients of Apollo Window Materials. NASA CR-1019, 1968.
- Oberg, J. E.: Flight Operations Directorate Proximity Operations Flight Procedures Handbook, Preliminary. Lyndon B. Johnson Space Center, JSC-10566, Nov. 11, 1982, pp. 1-1 to 4-41.
- Peercy, R. L., Jr.; Rassch, R. F.; and Rockoff, L. A.: Space Station Crew Safety Alternatives Study—Final Report, vol. 1—Final Summary Report. NASA CR-3854, 1985.
- Pennington, J. E.; and Brissenden, R. F.: Visual Capability in Rendezvous. *Astronaut. Aerospace Eng.*, vol. 1, no. 1, Febr. 1963, pp. 96-99.
- Pigg, O. E.; and Weiss, S. P.: Apollo Experience Report—Spacecraft Structural Windows. NASA TN D-7439, 1973.
- Plunkett, R. A.: Transmission Properties of Apollo Windows. Rept. K-MSK-K035, Lyndon B. Johnson Space Center, rev. Oct. 12, 1970.
- Pritchard, B. S.; and Blackwell, H. R.: Optical Properties of the Atmosphere and Highway Lighting in Fog. *Highway Res. Board Bull.*, no. 191, *Nat. Acad. Sci./Nat. Res. Council*. Pub. 617, 1958, pp. 7-16.
- Pritchard, B. S.; and Elliott, W. G.: Two Instruments for Atmospheric Optics Measurements. *J. Opt. Soc. Amer.*, vol. 50, no. 3, March 1960, pp. 191-202.
- Pustinger, J. V., Jr.; and Hodgson, F. N.: Identification of Volatile Contaminants of Space Cabin Materials. NASA CR-88636, 1967.
- Riel, D.; et al. [sic]: Configuration Analysis Review. McDonnell Douglas, Report VHJ344, Sept. 17, 1985.
- Ritter, O. L.: The Sun's Retina-Burning Power in Space. *Astronautik*, vol. 2, no. 4, 1961, pp. 300-309.
- Roach, F. E.; and Smith, L. L.: Absolute Photometry of the Light of the Night Sky; the Zenith Intensity of Haleakala (Latitude N20.7 deg) and at Fritz Peak (Latitude N39.9 deg). NASA CR-59011, 1964.
- Sampson, R. C.: Three-Dimensional Photoelastic Evaluation of Wire Reinforced Flexible Windows. NASA CR-66973, 1969.
- Schmidt, I.: Solar Irradiance up to 100 Kilometers. *Aerospace Med.*, vol. 33, no. 7, July 1962, pp. 802-813.
- Schneider, C. W.; and Bartley, S. H.: A Study of the Effects of Mechanically Induced Tension in the Neck Muscles on the Perception of Verticality. *J. Psychol.*, vol. 54, July 1966, pp. 245-248.
- Shirk, E. K.; and Price, P. B.: Observation of Trans-Iron Solar Flare Nuclei in an Apollo 16 Command Module Window. *Proc. 13th Intern. Cosmic Ray Conf. Denver*, Aug. 17-30, 1973, Vol. 2 (A74-30143 13-29), Univ. of Denver, 1974, pp. 1474-1478.
- Silva, R. M.; Jorris, T. R.; and Vallerie, E. M., III: The Air Force Space Navigation Experiment on Gemini (DOD/NASA Gemini Experiment D-9, Gemini IV and VII Flights). AFAL-TR-66-289, Sept. 1966.

- Smith, D. W.; and Lampkin, B. A.: Sextant Sighting Measurements from On Board the Gemini XII Spacecraft. NASA TN D-4952, 1968.
- Society of Automotive Engineers, Inc.: Pilot Visibility From the Flight Deck Design Objectives for Commercial Transport Aircraft. Aerospace Std. 580B, Nov. 1, 1978.
- Space Station Task Force, NASA Headquarters: Space Station Program Description Document, Book 3—System Requirements and Characteristics, Final Ed., TM-86652, 1984.
- Strughold, H.; and Ritter, O. L.: Eye Hazards and Protection in Space. *Aerospace Med.*, vol. 31, no. 8, Aug. 1960, pp. 670-673.
- Stuster, J. W.: Design Guidelines for a NASA Space Station: Habitability Recommendations Based on a Systematic Comparative Analysis of Analogous Conditions. Anacapa Sciences, Inc., Santa Barbara, Calif., 1984.
- Taylor, J. H.: Survey of Research Relating to Man's Visual Capabilities in Space Flight. Final Report, Lot III, U.S. Navy Contract NObs86012, Scripps Inst. Oceanogr., Univ. Calif., San Diego, June 1964.
- Taylor, J. H.: Vision. Ch. 13 in J. F. Parker, Jr., and V. R. West, eds., *Bioastronautics Data Book*, Second ed., NASA SP-3006, 1973, pp. 611-665.
- Trent, D. J.; and Rothermel, L. J.: Design of the Skylab MDA Window—Multiple Docking Adapter Window for Remote Sensing of Earth Resources. 25th Intern. Astronaut. Fed., Intern. Astronaut. Congress, Amsterdam, IAF Paper 74-031, Sept. 30-Oct. 5, 1974.
- Troester, R.: Reduction in Lunar Surface Visibility Due To Glare During a Landing Into the Sun. NASA CR-73503, 1968.
- U.S. Standard Atmosphere 1976, NASA, NOAA, USAF, NASA TM X-74335, 1976.
- Van Cott, H. P.; and Kinkade, R. G.; eds.: *Human Engineering Guide to Equipment Design*. Rev. ed., Amer. Inst. Res., Washington, 1972.
- Voas, R. B.: A Description of the Astronaut's Task in Project Mercury. *Human Factors*, vol. 3, no. 3, 1961, pp. 149-165.
- Vostok 1 in Orbit. *Astronautics*, November, 1962.
- Walsh, T. M.; Warner, D. N., Jr.; and Davis, M. B.: The Effects of a Gemini Left-Hand Window on Experiments Requiring Accuracy in Sighting or Resolution. NASA TN D-3669, 1966.
- Walsh, T. M.; and Warner, D. N., Jr.: Interferograms of Window Wavefront Deformations as a Measure of Angular Deviations to a Line of Sight. NASA TN D-5749, 1970.
- Warner, D. N., Jr.; and Walsh, T. M.: Effects of Edge Constraints on Optical Qualities of a Spacecraft Window. NASA TN D-4845, 1968.
- Wiederhorn, S. M.; Evans, A. G.; and Roberts, D. E.: A Fracture Mechanics Study of the Skylab Windows. *Fracture Mechanics of Ceramics*; Proc. Symp., University Park, Pa., July 11-13, 1973. Vol. 2. Plenum Press, 1974, pp. 829-842.
- Wiederhorn, S. M.; Evans, A. G.; Fuller, E. R.; and Johnson, H.: Application of Fracture Mechanics to Space-Shuttle Windows. *J. Amer. Ceram. Soc.*, vol. 57, no. 3, July 1974, pp. 319-323.
- Wolfe, T.: *The Right Stuff*. Bantam Books, 1979.
- Woodson, W. E.: *Human Factors Design Handbook: Information and Guidelines for the Design of Systems, Facilities, Equipment, and Products for Human Use*. McGraw-Hill, 1981, pp. 286-294.

- Zakharov, P. A.; Klimuk, P. I.; Lszarev, A. I.; Lebedinets, B. N.; Miroshnikov, M. M.; and Sevastianov, V. I.: Heat Conditions and the Erosion of Salyut 4 Windows by Micrometeoroid Impact. Investigation of Atmospheric-Optics Phenomena from the Salyut-4 Orbital Station. (A80-42558 18-46) Tartu, Akademiia Nauk Estonskoi SSR, Institut Astrofiziki i Fiziki Atmosfery, 1979, pp. 85-102. In Russian.
- Zink, D. L.: Visual Experiences of the Astronauts and Cosmonauts. *Human Factors*, vol. 5, no. 3, June 1963, pp. 13-27.
- Zook, H. A.; Flaherty, R. E.; and Kessler, D. J.: Meteoroid Impacts on the Gemini Windows. *Planet. Space Sci.*, vol. 18, no. 7, 1970, pp. 953-964.

INDEX

- Accommodation, 47,54-55
- Acuity (see Visual)
- Adaptation (see Visual)
- Advanced-window concept, 44
- Air bubbles, 48
- Albedo, 13 (see Lunar albedo)
- Allen, Joe, 14
- Allowable head/eye movement(s), 32-38
- Annealed glass (see Glass)
- Antireflective coating(s), 49, 55-56
- Anthropomorphic considerations, 27
- Apparent movement, 32
- Apparent target position, 32,50
- Approach to Space Station
 - Manned active, 20-24
 - Unmanned, 25
- Apollo windows, 49,74-77
- Apollo Lunar excursion module windows, 77
- Astigmatism, 55

- Bezel thickness, 29,33-34
- Blind spots, 24
- Body contact with window(s), 62
- Body orientation in microgravity, 3,30
- Breakage, 63

- Candlepower of sunlight, 9
- Clamp(s)
 - Design philosophy, 3
 - Fracture, 67
 - Glass contact, 50
- Cleaning
 - Hand, 66
 - Mechanical polishing/buffing, 67
- Cloud luminance from orbit, 13
- Coating(s) (see Optical)
- Color adaptation, 49-50
- Coloration, 49
- Color perception, 13,41
- Condensation, 80
- Connecting node(s), 8
- Contamination (see Surface, window)
- Contrast (see Visual)

- Crack
 - Propagation rate, 65
 - Velocity, 64-65

- Dark adaptation, 19,56
- Dark adaptation rate, 19
- Dark-adapted vision, 13,48
- Deployment maneuvers, 25
- Design eye point, 26,28,32-33
- Design eye volume, 26
- Detection range (see Target detection)
- Dichroic filter(s), 49
- Disorientation, 32,43
- Distance judgments, 54
- Dual windows, 35-36, 38

- Earthlight, 13,14
- Earth surface
 - Reflectance, 13 (see Albedo)
 - Time to view, 11-13
- Emergency repair kit(s), 68
- End cap geometry (module), 5,28
- Equipment storage, 67
- European Space Agency (Spacelab) windows, 88-89
- Experiment T002 (Skylab), 74
- Explosion projectiles, 62
- External contaminants (window), 60-61
- Eye location relative to window(s), 33
- Eye movement, allowable, 32
 - Horizontal rotation limits, 35-36
 - Vertical rotation limits, 35-36

- Fatigue fracture, 67
- Field of view
 - And rupture, 62
 - Binocular, 39,42,45
 - External, 4,28,32
 - Factors that determine, 28-38
 - Maximum, 26,38
 - Minimum, 40
 - Monocular, 39
 - Plots, 36

- Fixed size references, 39
- Flash blindness, 10
- Flat glass panes, 26
- Flaw detection, 46
- Flaw growth rate, 64
- Floodlights, 15
- Free-flyer payload(s), 25
- Futuristic viewport, 44

- Gap-width considerations, 35-38
- Gardner, Dale, 14
- Gemini capsule windows, 72-74
- Glare (see Veiling glare)
- Glass
 - Annealed, 46,61-62
 - Color variation(s), 49,63
 - Description of, 45-46
 - Flaw detection, 46,61-62
 - Impact load, 62
 - Puncture, 62
 - Rupture, 62
 - Tempered, 46,61-62
 - Transmissivity, 46-49
 - Two-component silicate, 64

- Habitability, 5
- Head movement, allowable, 32
 - Lateral translation, 28-32,37-38
 - Radial translation, 33-34
 - Rotation, 42,56
 - Vertical translation, 34
- Head-up display(s), 2,40
- Heat (see Infrared)
- Human Factors
 - Design concepts, 44
 - Design tradeoff parameters, 26-70
 - Of activating shield(s), 68
 - Of pane replacement, 67-68

- Ice formation, 46
- Illumination level(s)
 - Interior, 16
 - Of sunlight, 9

- Illumination sources
 - Exterior-mounted, 15
 - Interior-mounted, 15
- Image magnification, 26,54
- Image minification, 26,54
- Inclusions, 47
- Information transfer, 44
- Infrared radiation
 - Sources, 51
 - Transmission, 49
- Instrument panel(s), 32,39,42-45
- Internal contaminants, 59-60

- Lateral eye offset from window centerline, 28-32
- Leisure activity (Skylab), 81
- Light scatter, 50-52
- Light sources
 - External, 55
 - Internal, 55-56
- Line of sight
 - Deviation, 26,50,74
 - Displacement, 52-54
- Local horizontal (LH),20
- Local vertical (LV), 20
- Luminance of sunlight, 9
- Lunar albedo, 13
- Lunar reflected sunlight, 15

- Manned active approaches, 20-24
- Mercury capsule windows, 71-72
- Meridional size lens, 54
- Meteoroid impact, 61
- Micrometeorite effects, 49
- Mirror(s), 55
- Module configuration
 - Connection configurations, 8
 - "Figure eight," 7
 - Initial reference configuration, 4
- Modulus of rupture, 61-62
- Momentum vector operations
 - Minus, 22-23
 - Plus, 22-23
- Monochromatic filter(s), 49-50
- Moonlight, 13
- Motion sensitivity, 33-34,39-41,50,64
- Multispectral window (Skylab), 82

- Near-infrared, 48
- Near-ultraviolet, 48
- Neutral body position, 27
- Number of viewers per window, 41-44
- Number of windows, 43

- Optical
 - Clarity, 41
 - Coatings, antireflective, 49,56
 - Constancy, 47
 - Transmissivity, 47-50,63
- Orbital altitude parameters, 11
- Orbital inclination parameters, 11
- Orbital temporal characteristics, 10,11,12
- Overall size lens, 55

- Pane (see window)
- Particles, 52
- Peel-off film, 68
- Peripheral vision, 39-41,45
- Pitting, 49
- Plume impingement, 3,60-61
- Pressure
 - Differential, 50
 - Internal, 67
- Prism effect, 50-51
- Protective cover (see Shields)
- Proximity operations
 - Control station, 3,44
 - Definition, 3
 - General features of, 2,3,16
 - Human factors trade-off parameters, 16-17
 - Lighting for, 20
 - Orbital parameters, 20
 - Window requirements, 4,5,17

- Radius vector operations
 - Minus \bar{R} , 21
 - Plus \bar{R} , 21
- Range judgments, 39-41
- Range-rate judgments, 39-41
- Reaction time (see Visual)
- Reflection(s), 26,56
- Reticle, use of, 25

- Safety
 - Considerations, 43
 - Inspections, 5
 - Threat(s) list, 69
- Salyut windows, 90-93
- Scatter (see Light scatter)
- Seal(s), 67
- Searchlight effect, 7
- Seeds, 48
- Separation maneuvers, 25
- Shield(s), 57,68,80
- Shuttle windows, 35,83-87
- Size lens effect, 55
- Size perception, 47
- Situational awareness, 3,42,44
- Skylab windows, 46-47, 51,57,77-82
- Slant angle visibility, 12
- Slant range, 12
- Solar radiation characteristics
 - Angular constants, 10
 - Collimation angle, 10
 - Energy, 9
 - Electromagnetic radiation, 9
 - Eye protection, 46-49
 - Geometry, 7
 - Illumination, 7,9,12
 - Photometric constants, 9
 - Radiation, 9
 - Spectral distribution, 9,10
 - Temporal characteristics, 10
 - Thermal load, 9
- Soyuz capsule windows, 90
- Space debris, 62
- Spacelab windows, 88
- Space Station
 - Blind spots, 24
 - Construction activities, 26
 - Light sources, 15
- Spare(s)
 - Inventory, 68
 - Module configuration(s), 4
 - Storage, 68
- Stellar visual magnitude, 17-19
- Stress corrosion, 46
- Storage (stowage) of components, 67-68
- Sunrise duration on orbit, 11
- Sunset duration on orbit, 11
- Sunshades (includes covers, shutters), 56-57,80

- Surface, window
 - Contamination, 27
 - Haze, 55-56
 - Quality, 48
 - Reflection(s), 55-56

- Target contrast judgments, 47
- Target detection
 - Motion, 47
 - Range, 17-19, 47
- Target distance judgments, 54
- Tempered glass (see Glass)
- Thermal
 - Differential, 50
 - Load(s), 10
 - Shock, 61,63
- Transmission, window
 - Absolute, 48
 - Degradation, 48
 - Infrared, 49,80
 - Neutral, 3
 - Of BK-7 borosilicate glass, 64
 - Reduction of, 67
 - Spectral, 41,49,63
 - Ultraviolet, 47
 - Visible spectrum, 47
- Transmissivity, 47-49
- Trichroic filters, 49

- Ultraviolet radiation, 47,90
- Unmanned approach, 25

- Veiling glare, 15
- Velocity vector operations
 - Minus, 24-25
 - Plus, 24-25
- Visible spectrum, 48-49
- Visual
 - Acuity, 41
 - Adaptation, 19
 - Contrast, 7,49
 - Detection range, 47
 - Distraction, 56
 - Incapacitation, temporary, 9-10
 - Infrared sensitivity, 48
 - Judgments, 47
 - Magnitude (star), 17-19
 - Occlusion, 35-38
 - Reaction time, 41
 - Sensitivity, 39-41,48
 - Visual performance criteria, 6
 - Vostok capsule windows, 89-90

- Water condensation, 52
- Wedge effect (see Prism effect)
- Window(s)
 - Adjacent, 38
 - Assembly, 68-69
 - Cleaning procedures, 66
 - Contamination, 58-61
 - Damage, 58,61-65
 - Degradation, 58-61
 - Design assumptions, 2-3
 - Design eye point, 28
 - Design philosophy, 3
 - Dimensions, 2,26
 - Eye set-back, 26
 - Field of view, 17
 - Frame (see Clamp)
 - Gap width considerations, 35-37
 - Haze, 55
 - Integrity inspection, 65
 - Maintenance, 57,66-67
 - Number of, 43
 - Optical features, 45
 - Orientation, 56
 - Permanent damage, 61-65
 - Protection, 57,68-69
 - Reflection(s), 55
 - Removal, 67
 - Replacement, 67-68
 - Shape, 2,43
 - Size, 43
 - Storage of spares, 67
 - Surface contamination, 27
 - Surface degradation, 61
 - Transmissivity, 47-49
 - Visual angles, 29-34
 - Width, 26,29-32
- Work load, 68



Report Documentation Page

1. Report No. NASA TM-88233	2. Government Accession No.	3. Recipient's Catalog No.	
4. Title and Subtitle Space Station Proximity Operations Windows: Human Factors Design Guidelines		5. Report Date MARCH 1987	6. Performing Organization Code
		7. Author(s) Richard F. Haines	
9. Performing Organization Name and Address Ames Research Center Moffett Field, CA 94035		8. Performing Organization Report No. A-86185	10. Work Unit No.
		11. Contract or Grant No.	
12. Sponsoring Agency Name and Address National Aeronautics and Space Administration Washington, DC 20546		13. Type of Report and Period Covered Technical Memorandum	
		14. Sponsoring Agency Code	
15. Supplementary Notes Point of Contact: Richard F. Haines, MS 239-3, Ames Research Center, Moffett Field, CA 94035 (415)694-5719 or FTS 464-5719			
16. Abstract <p>Proximity operations refers to all activities outside the Space Station which take place within a 1-km radius. Since there will be a large number of different operations involving manned and unmanned vehicles, single- and multiperson crews, automated and manually controlled flight, a wide variety of cargo, and construction/repair activities, accurate and continuous human monitoring of these operations from a specially designed control station on Space Station will be required. Total "situational awareness" will be required. This paper presents numerous human factors design guidelines and related background information for control station windows which will support proximity operations. Separate sections deal with natural and artificial illumination geometry; all basic rendezvous vector approaches; window field-of-view requirements; window size, shape, and placement criteria; window optical characteristics as they relate to human perception; maintenance and protection issues; and a comprehensive review of windows installed on U.S. and U.S.S.R. manned vehicles.</p>			
17. Key Words (Suggested by Author(s)) Space Station Windows Human factors Human perception		18. Distribution Statement Unclassified - Unlimited Subject Category - 54	
19. Security Classif. (of this report) Unclassified	20. Security Classif. (of this page) Unclassified	21. No. of pages 107	22. Price A06