

NASA Technical Memorandum 100972

The Solar Dynamic Radiator With a Historical Perspective

(NASA-TM-100972) THE SOLAR DYNAMIC RADIATOR
WITH A HISTORICAL PERSPECTIVE (NASA) 12 p
CSCL 22B

N89-10117

G3/18 Unclass
0169389

K.L. McLallin
Lewis Research Center
Cleveland, Ohio

M.L. Fleming
LTV Missiles and Electronics Group
Dallas, Texas

F.W. Hoehn and R.L. Howerton
Rockwell International
Rocketdyne Division
Canoga Park, California

Prepared for the
23rd Intersociety Energy Conversion Engineering Conference
cosponsored by the ASME, AIAA, ANS, SAE, IEEE, ACS, and AIChE
Denver, Colorado, July 31—August 5, 1988





The Solar Dynamic Radiator With a Historical Perspective

K. L. McLallin
NASA Lewis Research Center
Cleveland, Ohio

M. L. Fleming
LTV Missile and Electronics Group
Dallas, Texas

F. W. Hoehn & R. L. Howerton
Rockwell International/Rocketdyne Division
Canoga Park, California

Abstract

A historical perspective on pumped-fluid loop space radiators provides a basis for the design of the Space Station Solar Dynamic (SD) power module radiator. SD power modules, capable of generating 25 kW (electrical) each, are planned for growth in Station power requirements. The Brayton (cycle) SD module configuration incorporates a pumped-fluid loop radiator that must reject up to 99 kW (thermal). The thermal/hydraulic design conditions in combination with required radiator orientation and packaging envelope form a unique set of constraints as compared to previous pumped-fluid loop radiator systems. Nevertheless, past program successes have demonstrated a technology base that can be applied to the SD radiator development program to ensure a low risk, low cost system.

Introduction

Various types of radiator design concepts for use in space are available to meet specific heat rejection requirements. For the Space Station Solar Dynamic (SD) Power Modules, a single phase, pumped liquid radiator has been selected as the baseline design (ref. 1). This heat rejection concept uses a pumped-fluid loop to acquire the heat rejected from the Closed Brayton Cycle power conversion unit and transport it to a deployable

array of radiator panels for rejection to space. This radiator design will benefit from previous space applications that include Apollo, Skylab, Shuttle, and Brayton Rotating Unit (BRU) program.

The area and mass of the space radiator are sensitive to the cycle heat rejection temperature. The panel design for the SD radiator will operate in a higher temperature range than previous space program experience. The current technology, however, is expected to be an extension of the previous methods, which are considered to be relatively mature.

The SD radiator will require thermal control coatings which exhibit a low solar absorptivity/emissivity ratio over the life of the radiator. The optical property degradation due to ultraviolet exposure is expected to be less severe for the SD radiator, since the panels are not exposed to direct sunlight.

The SD radiator panel array will require careful analysis to properly match thermal and hydraulic resistances in the fluid loop over the wide operating temperature range of the Brayton cycle. While data correlation will be necessary for flow network heat transfer, the analysis tools required to fully characterize the thermal/fluid loop have been successfully used and demonstrated on all past programs.

High reliability will be achieved for the heat rejection assembly by (1) selecting high reliability component designs, (2) providing micrometeoroid and space debris protection of the fluid loop components, and (3) incorporating appropriate component and fluid loop redundancy.

Structural integrity will also be achieved by utilizing an adhesively bonded aluminum honeycomb construction for the radiator panels. The concept is weight competitive, proven in flight, and is representative of current state-of-the-art fabrication techniques.

The SD heat rejection assembly has been designed to facilitate launch packaging and on-orbit construction by providing an integrated automatic deployment mechanism and support structure. The basic concept of scissors arms with cable actuation has been successfully flight demonstrated on a similar scale.

This report describes the radiator technology demonstrated on past programs and the current baseline configuration of the SD Power System radiator assembly.

The Apollo Command Service Module (CSM)

The Apollo CSM was involved in both earth orbital and lunar missions as well as the Skylab program (refs. 1 and 2). The Service Module (SM) incorporated a pumped-fluid loop radiator system, for the environmental control system (ECS), as shown in figure 1.

The radiator for the ECS was of a body-mounted type located at the rear of the SM (fig. 1). Two panels with flow tubes running circumferentially were plumbed in parallel. Each panel had a small panel in series on the downstream side. The radiator was designed to reject 2.0 kW (thermal) with a fluid inlet temperature less than 42 °C. In order to accommodate varying heat load conditions during a mission, the panels utilized a selective-stagnation design to control flow in the panel tubes during low loads in order to reduce the rejection capacity and therefore eliminate panel fluid freezeup (ref. 4). Radiator design characteristics are shown in table I.

The Apollo CSM radiator for the ECS performed as designed during the lunar missions. In addition, the selective stagnation feature with minor modifications allowed radiator operation at lower heat loads for LEO missions such as Skylab (ref. 5 and 6). The Apollo radiator demonstrated both flow stagnation control for low heat load and the ability to thermally model the system. The modeling effort for the Block II radiators demonstrated the need for accurate fluid properties over the entire fluid operating temperature range to adequately predict off-design performance (ref. 4).

Skylab

The Skylab program involved three manned missions over an eight month time period in 1973 and 1974. Skylab was initially inserted into a 435-km orbit at a 50° inclination resulting in a wide range in the orbital thermal environment due to vehicle attitudes and high Beta angles (+73.5°). Skylab incorporated a number of elements to perform the various mission functions (ref. 7). These elements include the orbital workshop (OWS), fixed airlock shroud (FAS), instrument unit (IU), airlock module (AM), multiple docking adapter (MDA), and Apollo telescope mount (ATM), as in figure 2.

Active thermal control was provided for these modules primarily by the AM. The Thermal Control System (TCS) in this module interfaced with a pumped fluid radiator mounted on the Structural Transition section (STS) and the MDA. The radiator had eleven body-mounted type panels with plumbing arranged in a parallel/series configuration as shown in figure 3.

In addition, the radiator panels incorporated the redundant loop in a shared-fin configuration. The maximum design heat load was 4.7 kW (thermal) and the maximum allowable radiator inlet temperature was 49 °C. Peak values encountered during the Skylab missions were 3.5 kW (thermal) and 24 °C. The radiator characteristics are shown in table I.

The TCS radiator performed satisfactorily during the Skylab missions. Extensive thermal analy-

ses were used to integrate the TCS and radiator and to predict on-orbit performance since full-scale thermal tests normally associated with qualifications were eliminated from the program (ref. 8). One anomaly was encountered during the manned missions for the coolant loop. Coolant leakage required servicing of the loop during the last manned mission. While the system continued to operate adequately, leakage continued after the maintenance activities and all sources of leaks were never resolved (ref. 9).

The ATM solar arrays were successfully deployed by using a scissors arm and cable mechanism (ref. 10). The demonstration, in space, of this large scale mechanism provides a technology base from which to develop a large scale deployment mechanism for the SD radiator panel. Each of the four arrays had five panels approximately 2.7 by 2.6 m in size as shown in figure 4.

The Space Shuttle Orbiter

The Space Shuttle Orbiter has been involved in manned operations in low earth orbit since 1981. The Orbiter is capable of multiple reflights, up to 100 missions lasting about 1 week in orbit. The Orbiter has large space radiators to accommodate thermal control of power, avionics, crew cabin environment, and payloads (ref. 11). The radiator panels are mounted on the interior surface of the cargo bay doors (as shown in fig. 5) to protect them during launch and reentry.

The Orbiter radiator system is capable of rejecting up to 30.5 kW (thermal) from 10 to 46 °C and return temperature can be selected at either 14.4 or 3.3 °C, with this control accomplished by radiator flow bypass. The radiator characteristics are shown in table 1. The panels are on two separate loops, with four panels in series on each payload bay door as shown in figure 6. The panels are approximately 3.2 by 4.6 m on each edge for a total radiating area of 175 m². Since the panels must survive many launches in a severe acoustic environment, the panel structure is well anchored to the doors and incorporates a relatively stiff aluminum matrix of honeycomb, flow tubes, and face sheets adhesively bonded together. The radiating

surfaces are coated with silver-backed Teflon adhesively bonded in an autoclave process.

The Shuttle Orbiter program has successfully demonstrated technology to fabricate radiator panels using a bonded aluminum matrix that incorporates the flow tubes inside a large, stiff panel structure (ref. 10). The thermal performance of this type of structure was demonstrated in tests and on Orbiter flights (refs. 12 to 14). The fabrication of radiator surfaces with a silver, teflon tape coating was also successfully demonstrated by the Orbiter radiator program. Significant advances in coating bonding integrity were achieved (ref. 15).

The Brayton Power System (BRU)

A Brayton space power system for integration with radioisotope or nuclear heat source was designed (ref. 16), built, and ground tested as part of the NASA Lewis Research Center space power development program during the 1960's and early 1970's. As part of this program, a flight-type space radiator was tested with the Brayton power generation system in the Space Power Facility (SPF) at Plum Brook Station, near Lewis. This radiator was designed for a 10 kW (electrical) Brayton system with a 5 year mission in low Earth orbit. The performance parameters are given in table I.

The radiator developed (refs. 17 and 18) to meet these mission requirements for the ground test was a cylindrical, pumped-fluid loop design with redundant coolant loops sharing the same fin structure capable of rejecting 17.6 kW (thermal). Basic features include laminar fluid flow, relatively high fluid inlet temperature (141 °C), and flow split to high and low temperature segments. The cylindrical design was constrained to fit within the envelope of a Saturn SIV-B stage for launch (about 6.6 m). The basic configuration is shown in figure 7.

A successful test program was conducted, including component and integrated Brayton system/radiator tests in a simulated space environment with the sun-shade cycle. The integrated

tests demonstrated cold startup, impacts of coolant flow loss and redundant loop start on the Brayton system, orbital sun-shade cycle impacts on Brayton power output, impact of step changes in sink temperature, and the effects of coolant flow rate on radiator capacity and Brayton power output (refs. 19 and 20). The design analyses correlated well with actual hardware test data, as the radiator was slightly oversized for the design operating conditions. No significant development or operational problems were encountered.

SD Power Module Radiator

The SD module, utilizing the Closed Brayton Cycle for power conversion, must reject 99 kW (thermal) at a 176 °C inlet temperature under the solar noon environment in a maximum insolation orbit. The heat load includes both cycle waste heat and the electronic component cooling with a required radiator outlet temperature less than 20 °C. This large temperature drop allows the radiator coolant loop to function at a relatively low flow rate of 0.54 kg/sec of FC-75 fluid. The radiator characteristics are shown in table 1. The array of radiator panels flow in parallel as shown in the coolant loop schematic, shown in figure 8. In addition, the radiator system must be designed to operate indefinitely with periodic maintenance. To meet on-orbit assembly requirements the radiator will be installed on a mechanism that allows stowage in the Orbiter cargo bay while attached to the SD module and deployment on-orbit to the operating configuration shown in figure 9.

The SD radiator design is based on many of the flight-proven design features discussed previously. The radiator panels, shown in figure 10, utilize a construction of aluminum honeycomb bonded to aluminum face sheets similar to the design for the Shuttle Orbiter radiators. The deployment mechanism concept is based on the technique used to deploy the ATM solar arrays on Skylab. The concept is being adapted to the SD application with techniques common to cable systems for aircraft control surfaces. The thermal control coating is Z-93 white paint which was used on the Apollo radiators. Radiator trade studies have resulted in a minimum weight system

that has a high probability of on-orbit survival. A fully redundant coolant loop flow system provides for full operational capability after one failure. Maintainability provisions include having the entire radiator array as a single orbital replacement unit (ORU) with the deployment mechanism providing for EVA or RMS actuation in case of cable drive system failure.

The baseline concept described here incorporates many flight proven technologies, but because of some unique thermal design requirements, extensions of the existing technology base will be necessary. The higher peak temperatures and resulting higher panel heat fluxes along with the large temperature drop through the panels require that several design options to the baseline concept be considered to reduce area, mass, and risk. These options involve (1) fluid tube extrusion design to improve heat transfer and reliability in the meteoroid/debris environment, (2) coolant fluid selection to improve heat transfer and eliminate transition Reynolds number flow, (3) thermal control coating evaluation for long life requirements, and (4) electronics coolant methods evaluation to eliminate the low outlet temperature constraint.

Summary

A description of the Space Station Solar Dynamic Power Module Radiator has been presented within the perspective of past space program radiator designs. Using this historical perspective, the SD Radiator will incorporate many technologies already demonstrated in manned space flight. Building on this technology base provides a low risk and low cost approach to heat rejection and thermal control for the SD Module. These technologies will provide space station power for Phase 2 and subsequent growth phases of the program.

References

1. Fleming, M. L.; and Hoehn, F.: Radiator Selection for Space Station Solar Dynamic Power Systems. *Energy-New Frontiers* (22nd IECEC). Vol. 1, AIAA, 1987, 208-213.
2. Apollo Program Summary Report. NASA TM X-68725, 1975 Section 4.4.6, 4.4.9, and 4.11.
3. Samonski, F. H. Jr.; and Tucker, E. M.: Apollo Experience Report: Command and Service Module Environmental Control System. NASA TND-6718, 1972.
4. Morris, D. W.: Thermal Design and Performance of the Apollo Block II Environmental Control System Radiators, CSD A-1215, NASA Johnson Space Center, 1974, (also, Guy, W. W., and French, R. J., SAE Paper 690620, 1969).
5. Schaefer, J. L.; and Vanderpol, G. A.: Skylab Program CSM Verification Analysis Report. (SD-70-266, North American) Rockwell, Corp.; NASA Contract NAS9-150) NASA CR-129842, 1970.
6. Moore, C. C., Jr. et al: Performance of the Apollo Block 2 Environmental Control System Radiators on Earth Orbital AAP Missions. (REPT-361-02, LTV ElectroSystems Inc.; NASA Contract NAS9-6840), NASA CR-92429, 1967.
7. Turnill, R. Ed.: *Jane's Spaceflight Directory*. 3rd Ed., Jane's Publishing Co. Ltd, London, 1987.
8. Butin, R. L.; and Donovan, M. B. Thermal Analysis of the Skylab Airlock Module. ASME Paper 74-ENAS-40, July 1974.
9. Hopson, G.D.; Littles, J.W.; and Patterson, W.C.: MSFC Skylab Thermal and Environmental Control System Mission Evaluation, Section VII-Airlock Module Coolant Loop. NASA TM X-64822, 1974.
10. Morse, A. R.: MSFC Skylab Apollo Telescope Mount. NASA TM X-64811, 1974.
11. Williams, J. L.; and French, R. J.: Space Shuttle Orbiter Radiator System. ASME Paper 77-ENAS-33, July 1977.
12. Behrend, A. F., Jr.; Chandler, G. D.; and Howell, H. R.: Thermal Performance Testing of the Space Shuttle Orbiter Radiator System. 11th Space Simulation Conference, A. C. Boud, ed., NASA CP-2150, 1980, pp. 305-317.
13. Howell, H. R.; and Williams, J. L.: Qualification of the Space Shuttle Orbiter Radiator System. SAE Paper 820886, July 1982.
14. Williams, J. L. et al: Challenges in the Development of the Orbiter Radiator System. Space Shuttle Technical Conference, Part 1, N. Chaffee, ed., NASA CP-2342-PT-1, 1985, pp. 480-489.
15. Fleming, M. L. et al: Shuttle Active Thermal Control System Development Testing. ASME Paper 74-ENAS-43, July 1974.
16. Klann, J. L.; Analysis and Selection of Design Conditions for a Radioisotope Brayton-Cycle Space Powerplant. NASA TN D-4600, 1968.
17. Miller, T. J.; Couch, J. P.; and Prok, G. M.: Design and Preliminary Testing of a Brayton Space Radiator Concept. 1971 Intersociety Energy Conversion Engineering Conference, SAE, 1971, pp. 403-408. (NASA TM X-67822).
18. Cintula, T. C.; Prok, G. M.; and Johnston, D. B.: Laminar Flow Studies of a Low-Temperature Space Radiator Model Using D-Shaped Tubes. NASA TN D-6727, 1972.
19. Cintula, T. C.; Prok, G. M.; and Smith, R. B.: Performance of a flight-type Laminar Radiator with a Brayton Power System. NASA TN D-7573, 1974.
20. Nussle, R. C.; Prok, G. M.; and Fenn, D. B.: Performance of a Brayton Power System with a Space Type Radiator. NASA TN D-7708, 1974.

TABLE I. - SPACE RADIATOR DESIGN AND PERFORMANCE CHARACTERISTICS

Program	Peak temperature, °C	Surface area, m ²	Flow regime	Fluid	Fluid path	Flow rate total, kg/s	Heat load, kW	Failure tolerance	Coating
Apollo	42	8.9	Laminar	Glycol/Water	Parallel	0.03	2.0	Fail safe	Z-93 White paint
Skylab	49	40.1	Laminar	Coolanol 15	Parallel/ Series	.07	4.7	Fail oper.	White paint
Shuttle	46	175	Turbulent	Freon-21	Parallel/ Series	.65	30.5	Fail safe	Silver/ Teflon
Solar dynamic	141	535	Laminar	DC-200	Parallel	.16	17.6	Fail oper.	White paint
Brayton rotating unit (BRU)	176	294	Turbulent Transition	FC-75	Parallel	.54	99.0	Fail oper.	Z-93 White paint

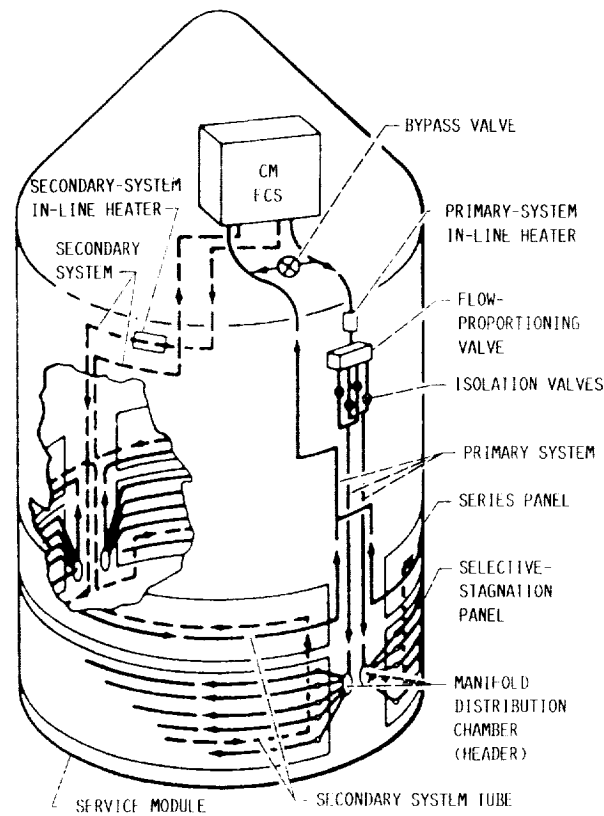

FIGURE 1. - SELECTIVE STAGNATION/FLOW PROPORTIONING RADIATOR SYSTEM FOR THE APOLLO CSM.

APOLLO TELESCOPE MOUNT
(ATM)
SOLAR OBSERVATION UNIT

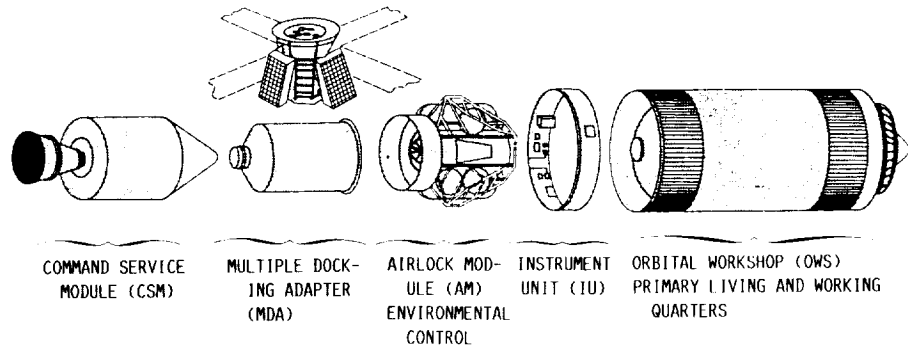

FIGURE 2. - SKYLAB CLUSTER ELEMENTS. (FROM REF. 7.)

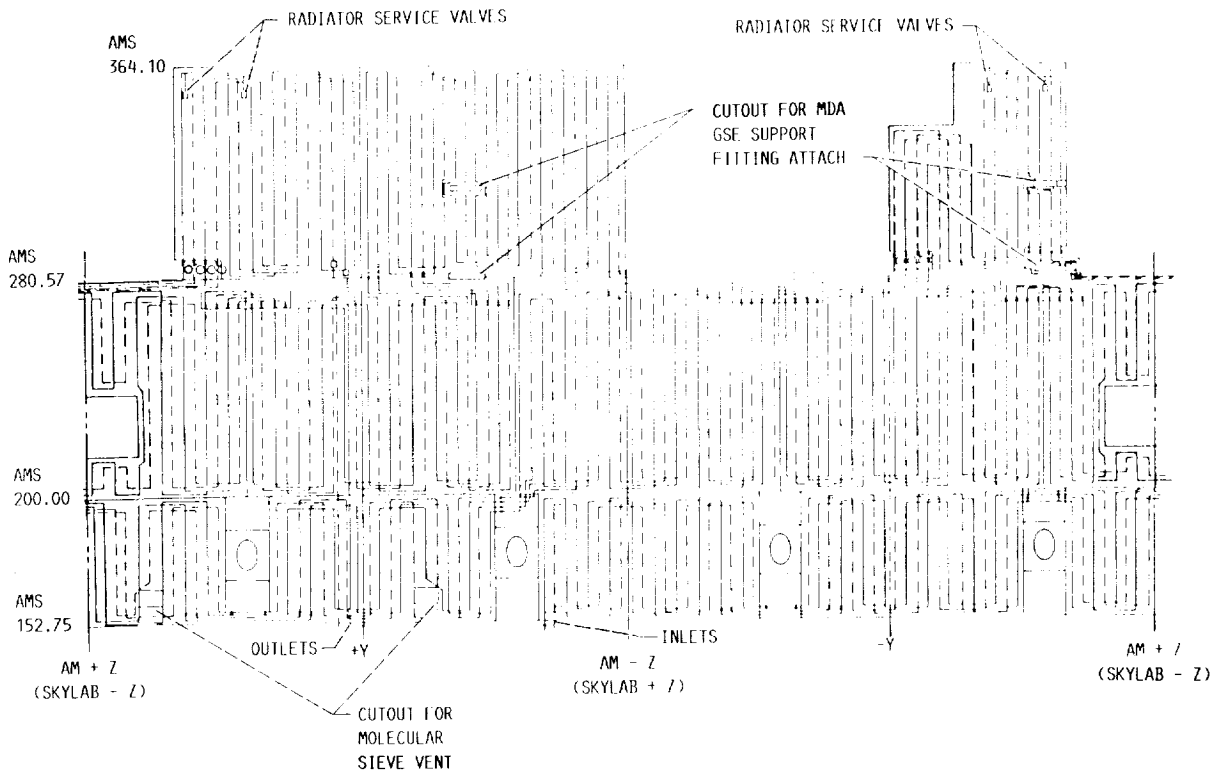

FIGURE 3. - THE AM/MDA RADIATOR STRETCHOUT LOOKING OUTBOARD.

ORIGINAL PAGE IS
OF POOR QUALITY

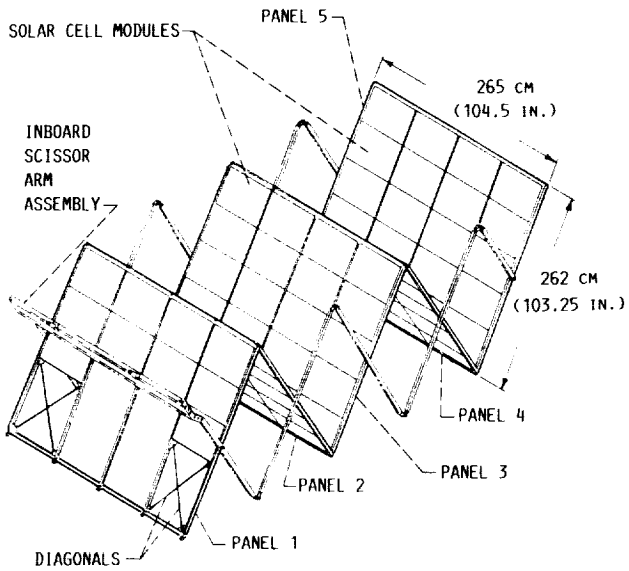

FIGURE 4. - THE ATM SOLAR ARRAY SCISSORS ARM DEPLOYMENT MECHANISM.

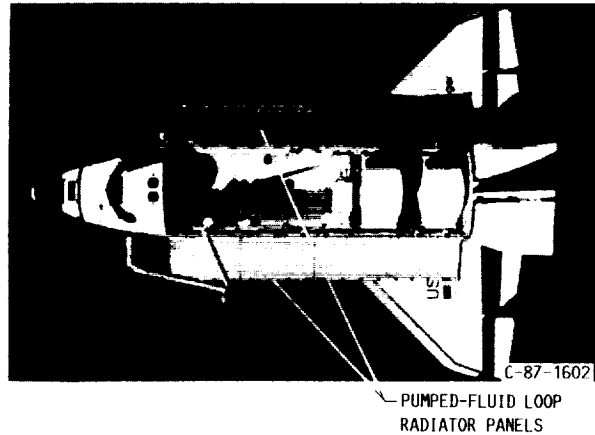

FIGURE 5. - SPACE SHUTTLE ORBITER RADIATOR SYSTEM.

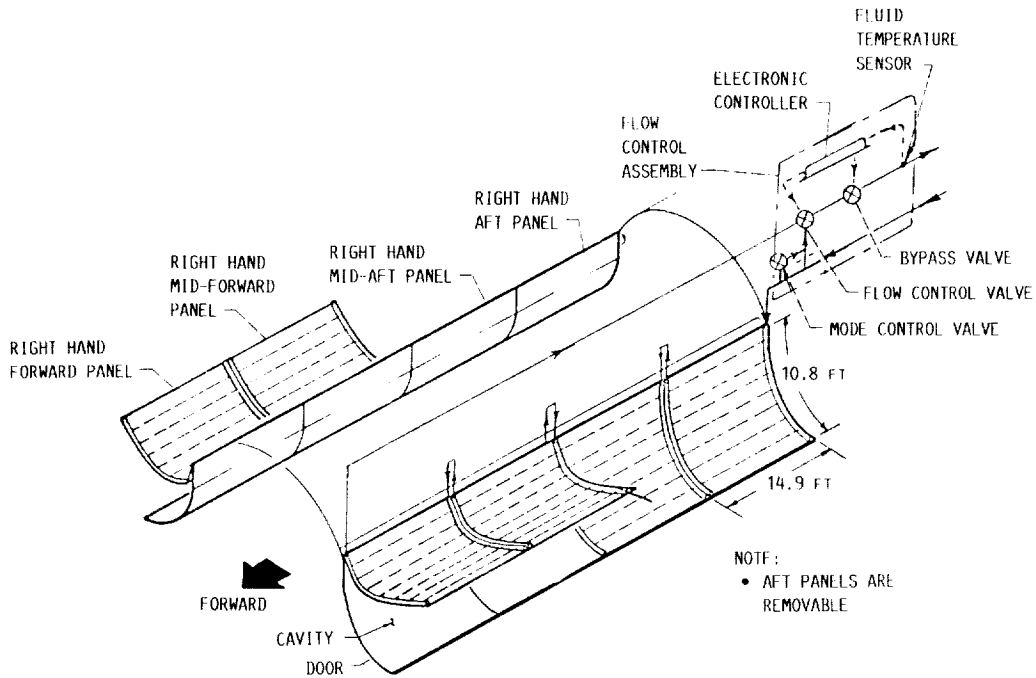

FIGURE 6. - ORBITER RADIATOR FLOW SCHEMATIC.

ORIGINAL PAGE IS
OF POOR QUALITY

ORIGINAL PAGE IS
OF POOR QUALITY

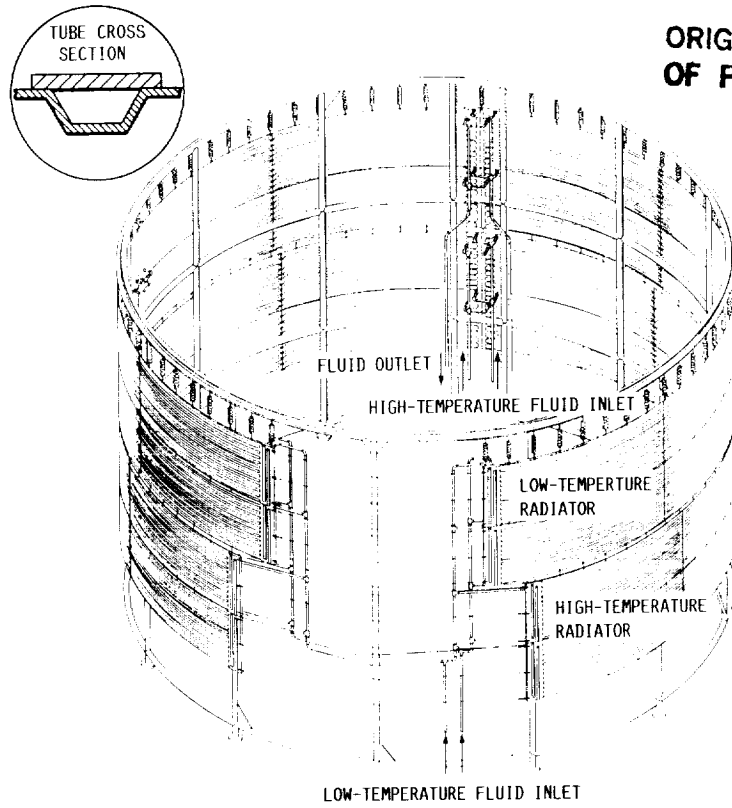

FIGURE 7. - THE BRAYTON ROTATING UNIT SPACE RADIATOR CONFIGURATION.

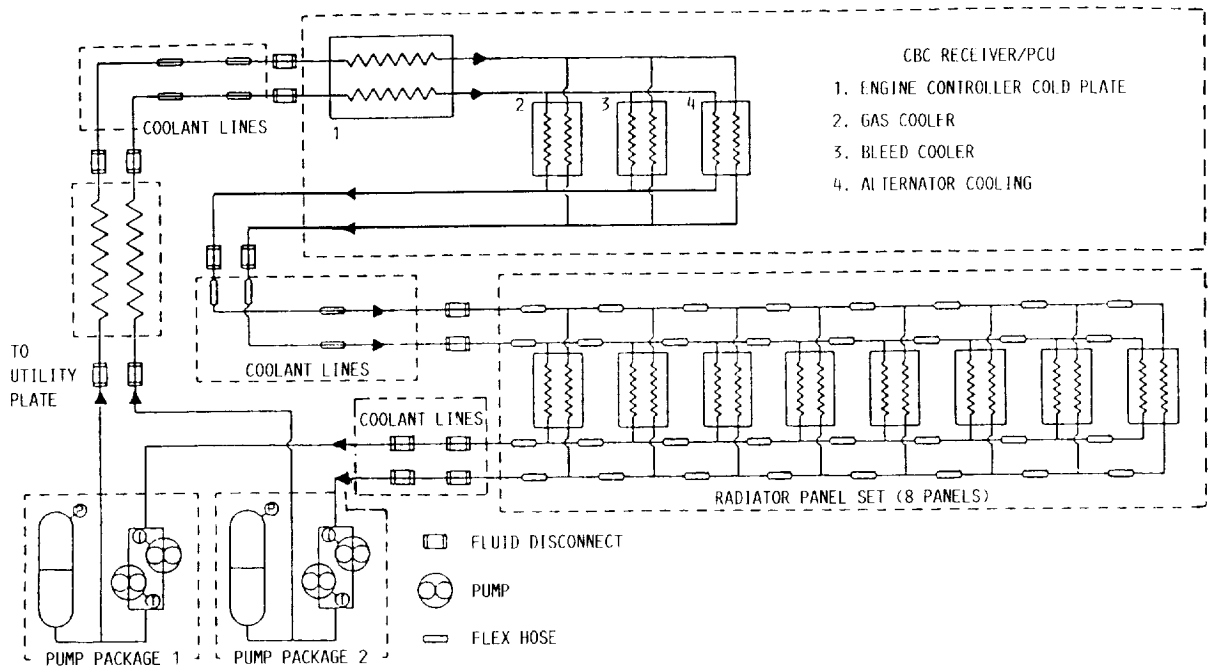

FIGURE 8. - SOLAR DYNAMIC RADIATOR PUMPED-FLUID LOOP FLOW SCHEMATIC.

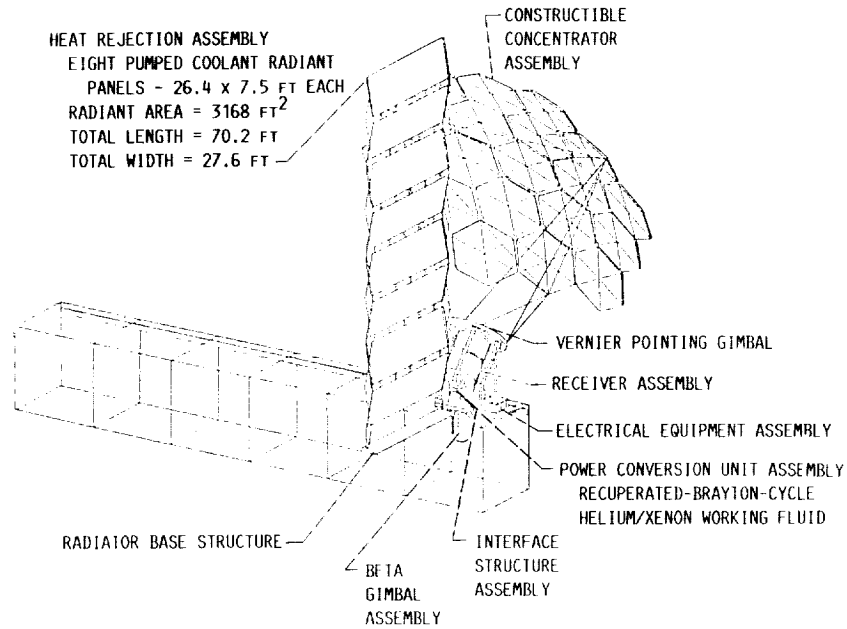

FIGURE 9. - THE SOLAR DYNAMIC POWER MODULE OPERATIONAL CONFIGURATION.

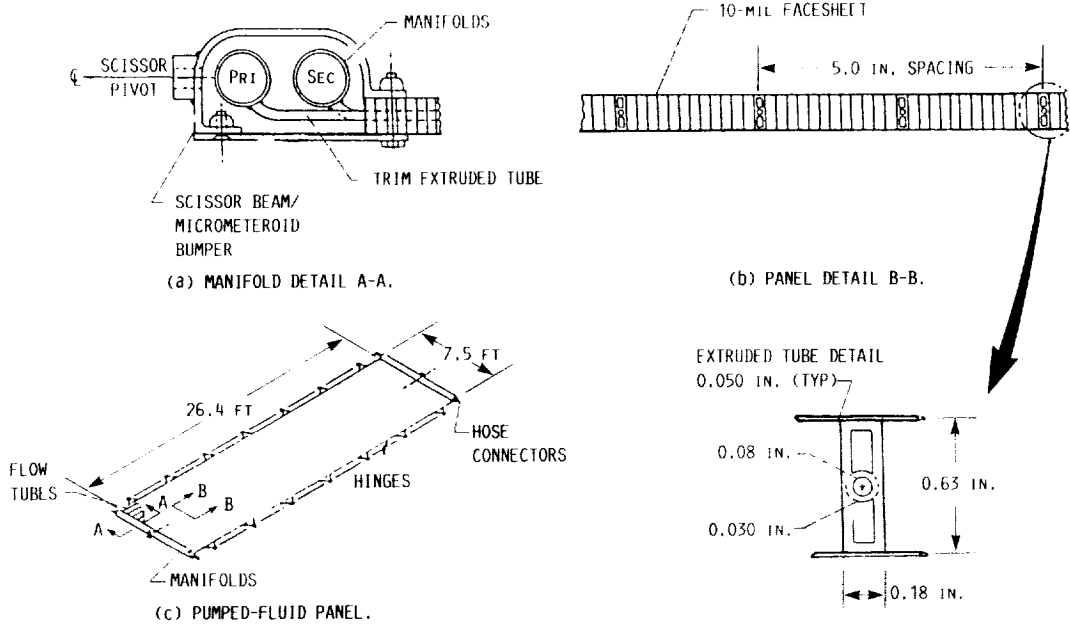
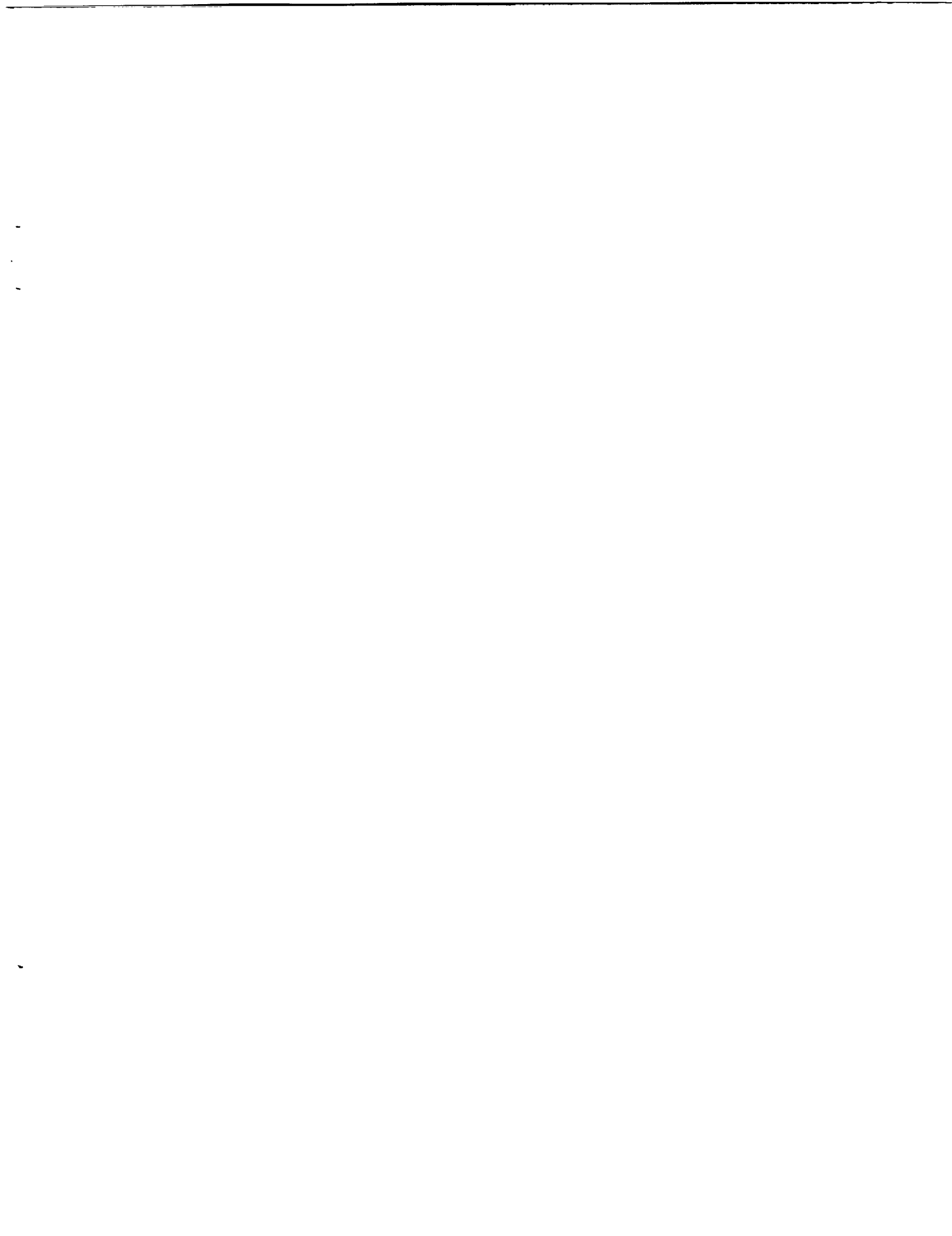

FIGURE 10. - SOLAR DYNAMIC RADIATOR PANEL STRUCTURE.



Report Documentation Page

1. Report No. NASA TM-100972		2. Government Accession No.		3. Recipient's Catalog No.	
4. Title and Subtitle The Solar Dynamic Radiator With a Historical Perspective				5. Report Date	
				6. Performing Organization Code	
7. Author(s) K.L. McLallin, M.L. Fleming, F.W. Hoehn, and R.L. Howerton				8. Performing Organization Report No. E-4265	
				10. Work Unit No. 474-52-10	
9. Performing Organization Name and Address National Aeronautics and Space Administration Lewis Research Center Cleveland, Ohio 44135-3191				11. Contract or Grant No.	
				13. Type of Report and Period Covered Technical Memorandum	
12. Sponsoring Agency Name and Address National Aeronautics and Space Administration Washington, D.C. 20546-0001				14. Sponsoring Agency Code	
15. Supplementary Notes Prepared for the 23rd Intersociety Energy Conversion Engineering Conference cosponsored by the ASME, AIAA, ANS, SAE, IEEE, ACS, and AIChE, Denver, Colorado, July 31—August 5, 1988. K.L. McLallin, NASA Lewis Research Center; M.L. Fleming, LTV Missiles and Electronics Group, Dallas, Texas; F.W. Hoehn and R.L. Howerton, Rockwell International, Rocketdyne Division, Canoga Park, California					
16. Abstract A historical perspective on pumped-fluid loop space radiators provides a basis for the design of the Space Station Solar Dynamic (SD) power module radiator. SD power modules, capable of generating 25 kW (electrical) each, are planned for growth in Station power requirements. The Brayton (cycle) SD module configuration incorporates a pumped-fluid loop radiator that must reject up to 99 kW (thermal). The thermal/hydraulic design conditions in combination with required radiator orientation and packaging envelope form a unique set of constraints as compared to previous pumped-fluid loop radiator systems. Nevertheless, past program successes have demonstrated a technology base that can be applied to the SD radiator development program to ensure a low risk, low cost system.					
17. Key Words (Suggested by Author(s)) Solar dynamic Space radiator Space station Space power			18. Distribution Statement Unclassified—Unlimited Subject Category 18		
19. Security Classif. (of this report) Unclassified		20. Security Classif. (of this page) Unclassified		21. No of pages	22. Price*



National Aeronautics and
Space Administration

Lewis Research Center
Cleveland, Ohio 44135

Official Business
Penalty for Private Use \$300

SECOND CLASS MAIL

ADDRESS CORRECTION REQUESTED



Postage and Fees Paid
National Aeronautics and
Space Administration
NASA-451

NASA
