

COMPACT IMAGING SPECTROMETER FOR INDUCED EMISSIONS

NAG8-060

Final Technical Report for Period
March 31, 1986 through February 1, 1988

Prepared by

Douglas G. Torr
Principal Investigator

School of Science
Physics Department
The University of Alabama in Huntsville
Huntsville, AL 35899

(NASA-CR-183187) COMPACT IMAGING
SPECTROMETER FOR INDUCED EMISSIONS Final
Technical Report, 31 Mar. 1986 - 1 Feb. 1988
(Alabama Univ.) 20 p CSCL 14B

N89-10264

Unclas
G3/35 0161096

Prepared for

National Aeronautics and Space Administration
George C. Marshall Space Flight Center
Marshall Space Flight Center, Alabama

September, 1988

FINAL REPORT ON NASA GRANT NAG8-060

"COMPACT IMAGING SPECTROMETER FOR INDUCED EMISSIONS"

All tasks listed in the original proposal were completed successfully. The CCD detector system was fabricated, tested and installed in the Compact Imaging Spectrometer. All tasks were accomplished within the budget allocated for these tasks. All electronics and cabling required to integrate the detector into the spectrometer and associated machining was completed and installed.

The instrument is now undergoing tests at MSFC and will be taken into the field for further sky tests this month at McDonald Observatory in Texas.

A final report on the instrument was presented by D. G. Torr at the 2nd Space Station Contamination Workshop held in Huntsville, Alabama, May 10-11, 1988. The attached preprint will be published as a NASA conference publication and is due to appear later this year.

A COMPACT IMAGING SPECTROMETER FOR STUDIES OF SPACE VEHICLE
INDUCED ENVIRONMENT EMISSIONS

M. R. Torr

Space Science Laboratory
NASA Marshall Space Flight Center
Huntsville, AL 35812

and

D. G. Torr

University of Alabama in Huntsville
Huntsville, AL 35899

Abstract. On the basis of spectral measurements made from the Space Shuttle and on models of the possible Space Station external environment, it appears likely that, even at the planned altitudes of Space Station, photon emissions will be induced. These emissions will occur to some degree throughout the ultraviolet-visible-infrared spectrum. The emissions arise from a combination of processes including gas phase collisions between relatively energetic ambient and surface emitted or re-emitted atoms or molecules, where the surface raises some species to excited energy states. At the present time it is not possible to model these processes or the anticipated intensity levels with any accuracy, as a number of fundamental parameters needed for such calculations are still poorly known or unknown. However, it is possible that certain spectral line and band features will exceed the desired goal that contaminant emissions not exceed the natural zodiacal background. However, in the near infrared and infrared, it appears that this level will be exceeded to a significant degree. Therefore it will be necessary to monitor emission levels in the vicinity of Space Station, both in order to establish the levels and to better model the environment. In this note, we briefly describe a small spectrometer that is suitable for monitoring the spectrum from 1200 Å to \lesssim 12,000 Å. This instrument uses focal plane array detectors to image this full spectral range simultaneously. The spectral resolution is 4 to 12 Å, depending on the portion of the wavelength range.

Introduction

Information on the nature of induced optical glows and halos near space vehicles is limited at present, and fundamental spectral characteristics have not yet been measured. While the uncertainties are large, preliminary studies (see, for example, Torr 1988; Fraser et al., 1988) indicate that spectral emission levels near Space Station should be monitored on a routine basis. We have developed a small imaging spectrometer which can be readily accommodated for the purpose of measuring induced spectral contamination over a wavelength range extending from the ultraviolet to the near infrared. A schematic illustration of the instrument is shown in Figure 1. The design takes advantage of state-of-the-art technology, and what has been learned in the

past ten years of developing imaging spectrometers for use in space, to achieve considerable data gathering capability in a compact package that is very undemanding in terms of resource requirements. Two of the units shown in Figure 1 are required to cover the full wavelength range discussed here.

Compact Spectrometer Design

The optical configuration of the instrument is shown in Figure 2. An off-axis parabolic telescope mirror images the field of view onto the entrance slit to the spectrometer. The slit is followed by a concave, aberration-corrected grating which acts as both the dispersion and the focussing element. The spectrum is then imaged on the focal plane detector system which consists of an intensified charge coupled device (CCD) array. As was mentioned above, two such units are required to cover the full wavelength range of 1200 Å to $\lesssim 12,000$ Å; one covering the ultraviolet (1200 Å to 4000 Å) and the second covering the visible/near infrared (4000 Å to $\lesssim 12,000$ Å). The spectrum from 1200 Å to $\sim 12,000$ Å is imaged simultaneously. Therefore there are no temporal ambiguities in correlating one part of the spectrum with another. This capability is important in assessing the features at times when the environment might be changing relatively rapidly (for example; terminator crossings, articulation of payload elements, ventings, etc.).

As the wavelength range of each unit exceeds the effective range of any single photocathode material, the image intensifiers used here are highly customized with one half of the intensifier window coated with one material, and the other half coated with another. Furthermore, the grating is divided into sub-elements. The longer wavelength channel incorporates a matrix of four gratings, each designed for a segment of the wavelength range (4000 to 6000 Å, 6000 to 8000 Å, 8000 to 10,000 Å, and 10,000 to 12,000 Å, respectively). The gratings are individually designed and aligned in such a way that all four produce a flat spectrum on the same image plane. The focal plane is defined by the window of the image intensifier. In the case of the visible/near infrared channel, half of the photocathode is S20, and half is S1. The image plane is illustrated in Figures 3 and 4.

In the case of the ultraviolet channel, the grating is split into two and the photocathode is CsTe on one half (1200 Å to 2000 Å) and bialkali material on the other half (2000 Å to 4000 Å).

The detector is a generation II proximity-focussed image intensifier which is fiber-optically coupled to the surface of a 488 x 380 element CCD. The detector is a continuation of several years of development in this area by our group (see Torr et al., 1986). The CCD is cooled to -30 °C to reduce thermal noise, and the longer wavelength channel has the photocathode cooled to ~ 0 °C for the same reason. The CCDs are cooled using thermoelectric coolers and heat pipes are used to remove the heat to a cold plate or passive radiator.

The basic instrument parameters are shown in Table 1 and further details of the design and performance are given elsewhere (Torr et al., 1988).

Sensitivity

In order to be able to assess whether the induced spectral environment exceeds the goal for such contamination, namely, the zodiacal background, the monitoring instrumentation should be capable of measuring down to the levels of the natural background. The zodiacal background varies with position relative to the Sun and also with wavelength. However, levels of 0.1 to 0.2 R/A are typical for much of the visible and near infrared.

The instrument sensitivity for a line source is computed from

$$S = \frac{10^6}{4\pi} \cdot A\Omega \cdot \epsilon \cdot q_e \text{ (counts/sec/R)}$$

where ϵ is the combined reflectance of the optics and q_e is the quantum efficiency of the detector photocathode. To evaluate this in the visible, where typical mirror reflectivities are 95% and a grating efficiency of 50% is reasonable; $\epsilon = 0.45$. An average value for q_e in the visible is ~10%. A is the collecting area per channel (4 cm^2) and Ω , the solid angle, is 4.48×10^{-5} sr, so for a line emission in the visible,

$$S_{\text{line}} = 0.57 \text{ counts/sec/R.}$$

For a continuum emission the sensitivity would have to be modified by the number of Angstroms per pixel multiplied by the number of pixels in a slit image; i.e., $2000 \text{ \AA}/488 \times 3 = 12 \text{ \AA}$.

$$\therefore S_{\text{continuum}} = 6.84 \text{ counts/sec/R/\AA.}$$

From this we can compute the time that would be needed to measure a 0.1 R/A signal to a signal to noise ratio of 5. The time required is 36 seconds.

For the UV, the aperture and slit length is doubled and so the sensitivity increases by a factor of 4. In the near infrared, the S1 photocathode material is substantially less sensitive. To measure to the 1R/A level with a signal to noise ratio of 5, a five minute integration is required.

Summary

An instrument with the properties described above would provide a valuable monitoring device for purposes of evaluating levels of contamination emissions in the vicinity of the Space Station, and to provide data necessary to an understanding of the processes taking place in this environment.

Table 1. Summary of Instrument Parameters

Optical Performance	VIS/IR Unit	UV Unit
wavelength range, Å		
channel 1	9800 - 11,800	2000 - 4000
2	7800 - 9,800	1200 - 2000
3	5800 - 7,800	
4	3800 - 5,800	
dispersion	4 Å/pixel	4 Å/pixel; 2 Å/pixel
resolution (at 3 pixels)	12 Å	12 Å; 6 Å
f# per channel	6.25	3.1
focal length	125 mm	125 mm
slit length	7 mm	14 mm
slit width	0.1 mm	0.1 mm
field of view	3.2° x 0.045°	6.4° x 0.045°
<u>Instrument</u>		
weight	6 kgms	6 kgms
dimensions	30 x 20 x 70 cm ³	30 x 20 x 70 cm ³
power	20 watts -10	20 watts 2

References

- Fraser, M.E., A Gelb, B.D. Green, and D.G. Torr, Calculation of Space Station infrared irradiance from atmosphere-induced emissions, in Proceedings of Workshop on Space Station Contamination, ed. M.R. Torr, J.F. Spann, and T.W. Moorehead, NASA Conference Publication, 1988.
- Torr, D.G., Space Station contamination study: assessment of contaminant spectral brightness, in Proceedings of Workshop on Space Station Contamination, ed. M.R. Torr, J.F. Spann, and T.W. Moorehead, NASA Conference Publication, 1988.
- Torr, M.R., T.W. Baldrige, H. Dougani, V. Hyatt, A.G. Loughhead, J. Owens, A. Tejada, and D.G. Torr, A compact imaging spectrometer for space applications, Applied Optics, submitted, 1988.
- Torr, M.R., D.G. Torr, R. Baum, and R. Spielmaker, Intensified-CCD focal plane detector for space applications: A second generation, Applied Optics, 25, 2768, 1986.

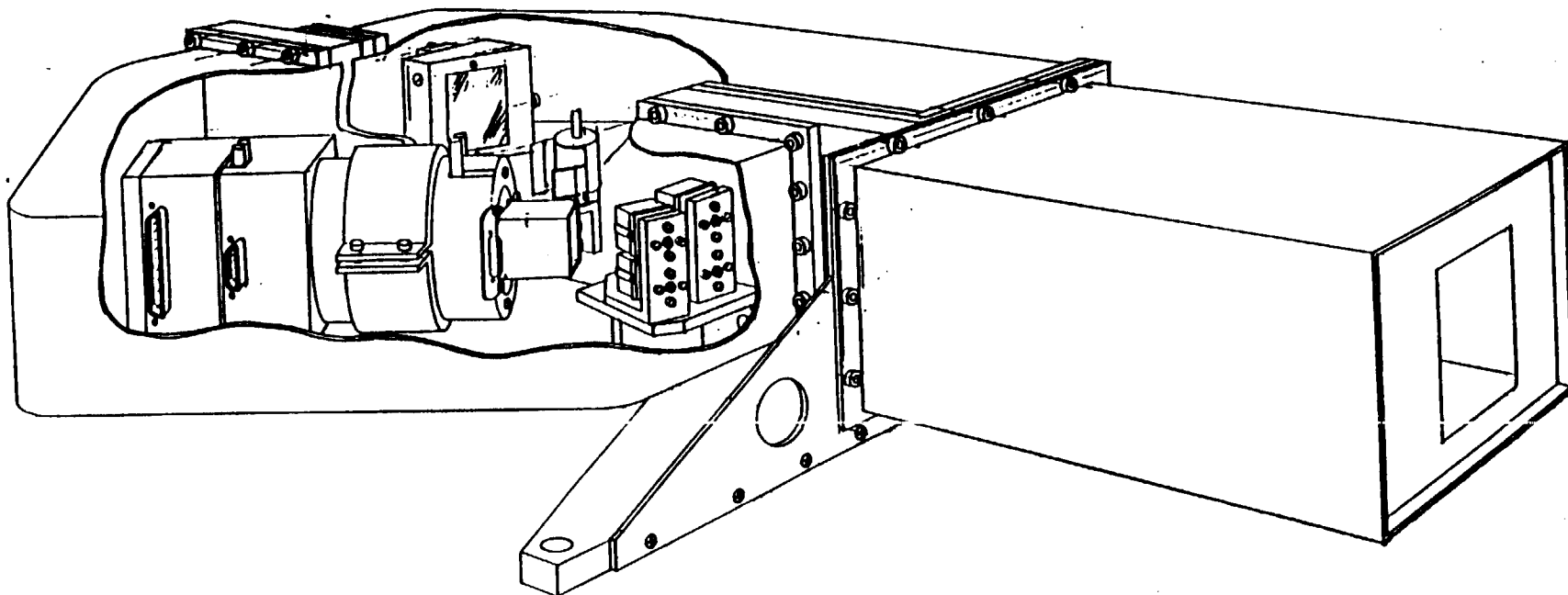

COMPACT SPECTROMETER

Figure 1. Schematic illustration of one unit of the compact spectrometer.

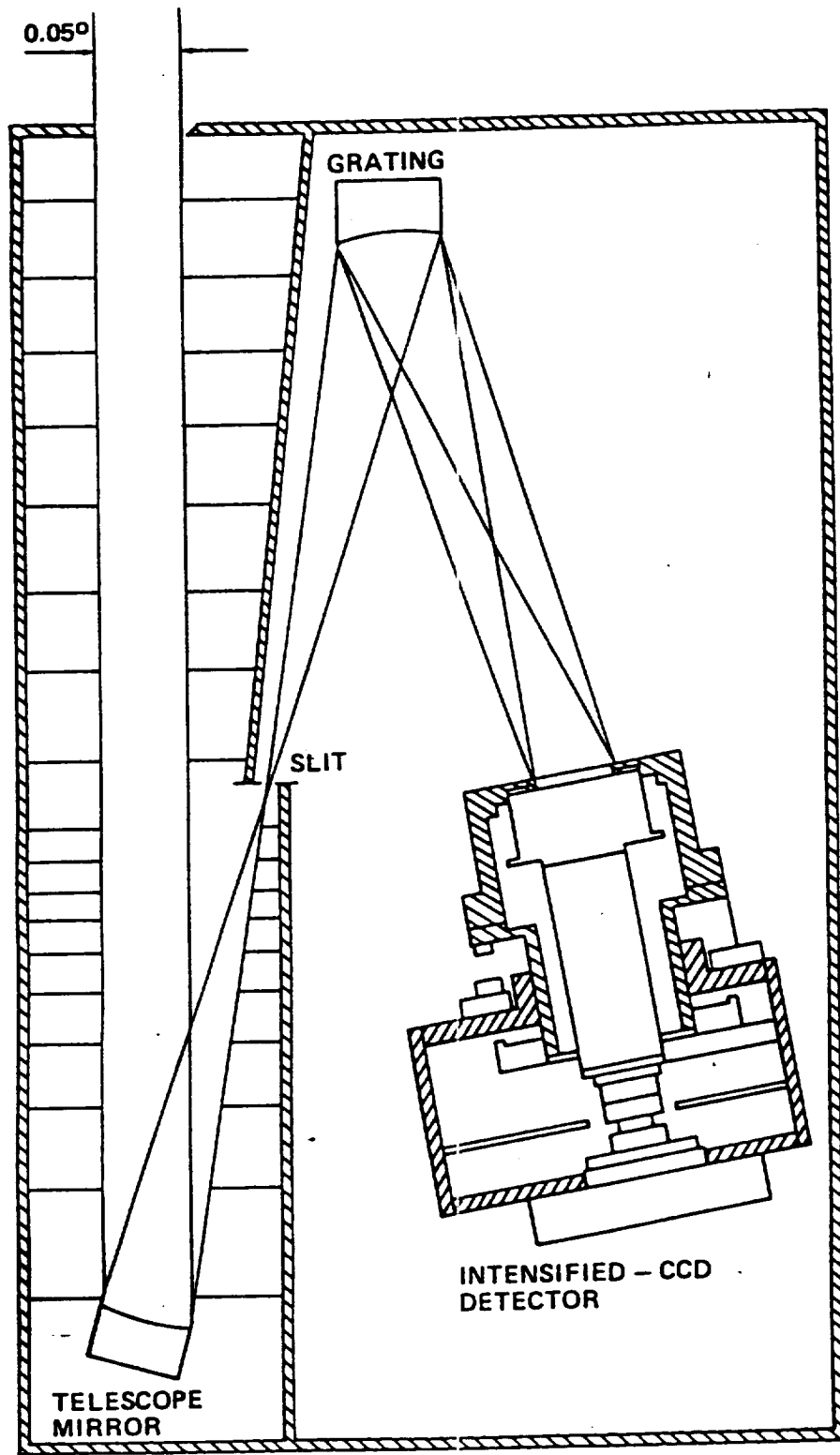

ILLUSTRATION OF IMAGING SPECTROMETER

Figure 2. Optical configuration of compact spectrometer, illustrating the split field and the grating matrix.

SIDE VIEW (AND SLIGHTLY ABOVE)

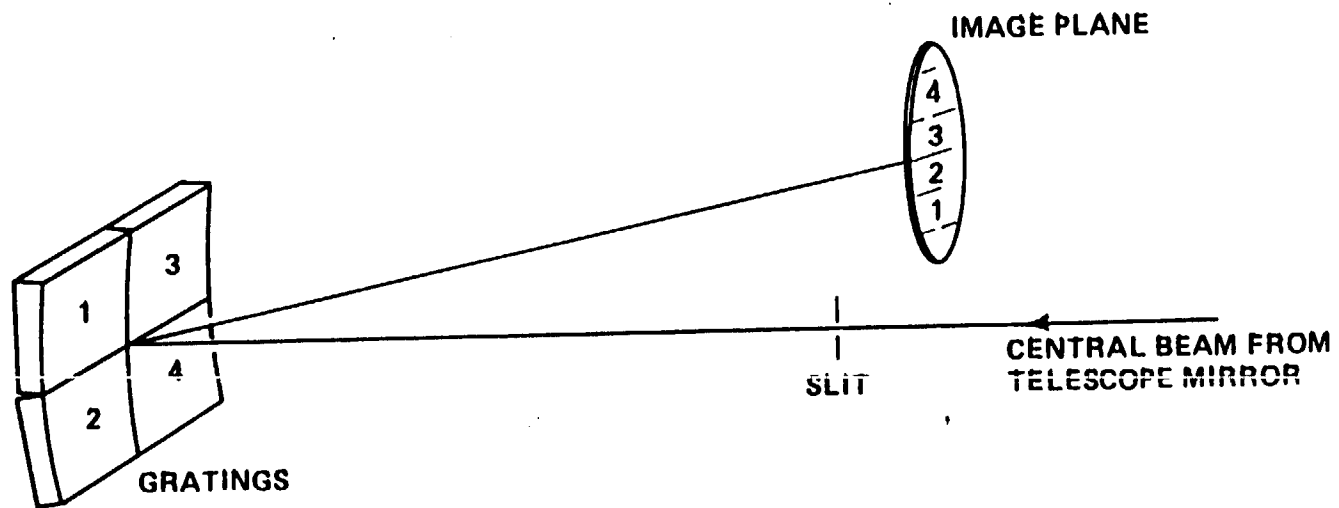

Figure 3. Schematic illustration of the four-grating single focal plane system.

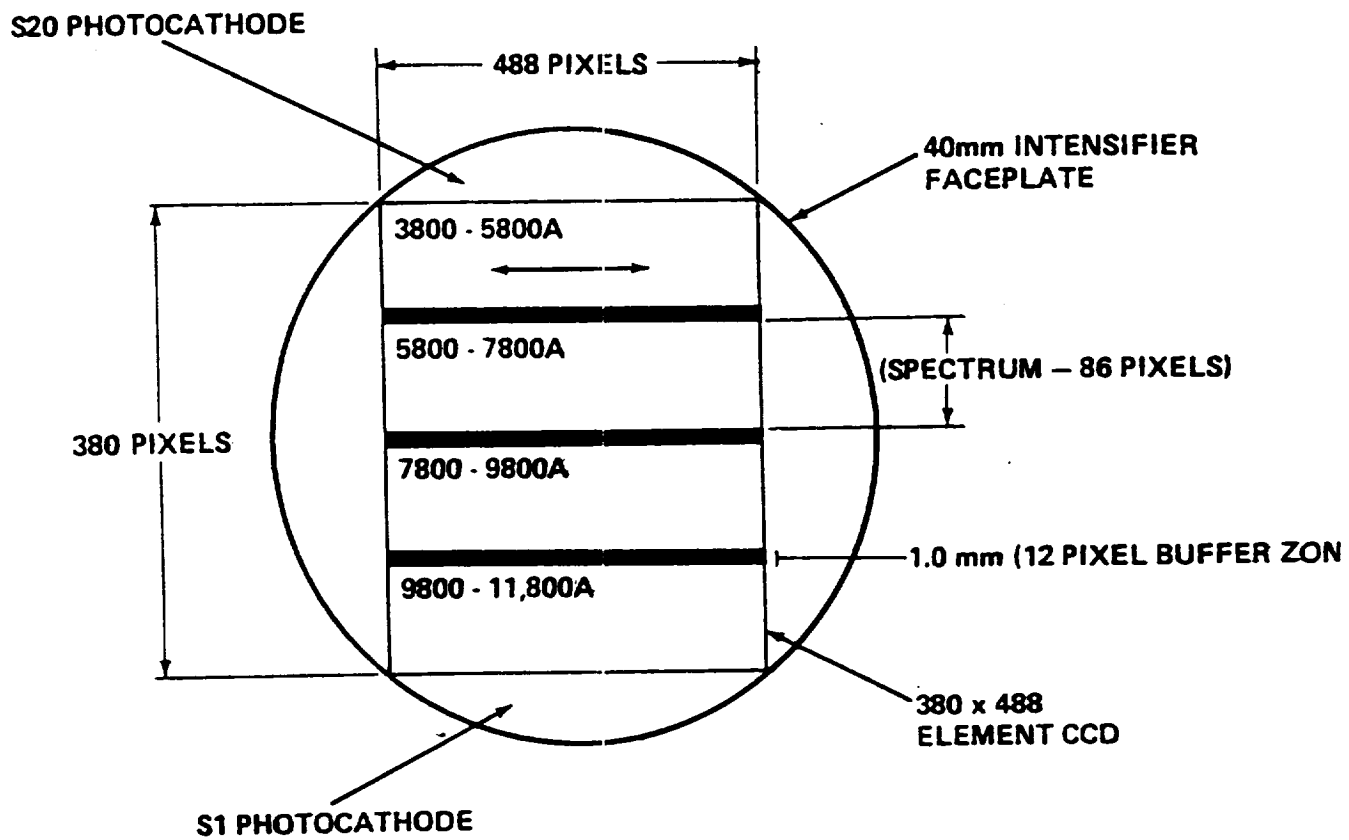

FIGURE 1.2.2 PROJECTION OF SPECTRAL IMAGE ON INTENSIFIED-CCD DETECTOR SYSTEM

Figure 4. Projection of spectral image on intensified-CCD detector system.