

N89 - 10906

Dr. S. Staniek, Dr. G. Otto, DFVLR, D-5000 Köln 90
Dr. J. Döpkins, MBB-ERNO, D-2800 Bremen 1, FRG

FUTURE MAUS PAYLOAD AND THE TWIN-MAUS CONFIGURATION

Abstract

The German MAUS project was initiated in 1979 for optimum utilization of NASA's Get-Away-Special (GAS) program. The MAUS standard system has been developed to meet the NASA requirements for flying in Get-Away-Special containers. MAUS can accommodate a wide variety of GAS-type experiments, and offers a range of services to experimenters within a framework of standardized interfaces.

Currently, four MAUS payloads are being prepared for future Space Shuttle flight opportunities, and are described in this paper. The experiments include critical Marangoni convection, oscillatory Marangoni convection, pool boiling, and gas bubbles in glass melts. Two of them are reflights with modified scientific objectives, and the other two are new experiments. Scientific objectives as well as experiment hardware will be presented together with recent improvements to the MAUS standard system, e.g. new experiment control and data management unit and a semiconductor memory.

A promising means of increasing resources in the field of GAS-experiments is the interconnection of GAS containers. This important feature to meet the challenge of future advanced payloads has recently been studied. In the TWIN-MAUS configuration, electrical power and data will be transferred between two containers mounted adjacent to each other.

1. Scientific Objectives

The experiments in preparation are from the area of materials science and the results will improve the understanding of selected basic microgravity phenomena (Ref. 1).

The complex features of Marangoni convection will be further elucidated by two separate experiments. The objectives are as follows: documentation of the influence of iso-rotation on the steady and oscillatory state of convection, evaluation of the shape stability of the floating zone configuration during rotation, determination of the influence of higher Marangoni numbers on the hydrodynamic stability by variation of the temperature gradient. Convection is made visible in silicone oil by dispersed Al_2O_3 particles.

In a reflight of a previous successful MAUS experiment the onset of oscillatory Marangoni convection in sodium nitrate is further investigated. The frequency spectrum at higher Marangoni numbers with different aspect ratio will be measured and analysed to describe the transition to turbulence. In ground-based and flight experiments the Prandtl number, the aspect ratio and the gravity influence are varied systematically.

Pool Boiling (nucleate boiling) and forced convection are the most effective heat transfer mechanisms. From the many fluid physics phenomena which are observed in boiling, kinetic heat and mass transport by evaporation and condensation is independent of gravity. This experiment will lead to a physical separation of the gravity driven parameters and trence to a better understanding of the boiling process.

Fining is one of the most important processes in technical glass fabrication. The removal of gas bubbles from glass melts can be achieved in two ways: rising of the bubbles caused by buoyancy (which does not occur in microgravity) and dissolution diffusion. The shrinking of a He-bubble at around 1100°C was successfully recorded in a previous MAUS experiment. This investigation will be performed at the higher temperature of 1300°C to complement data on the diffusion in a wider temperature range. The convectional influence is expected to be stronger, and a larger difference between terrestrial and space experiments because of reduced viscosity will result.

2. Experiment Hardware

In MAUS experiment DG 302 thermal Marangoni convection in a floating zone is initiated by an axial temperature gradient along a free surface.

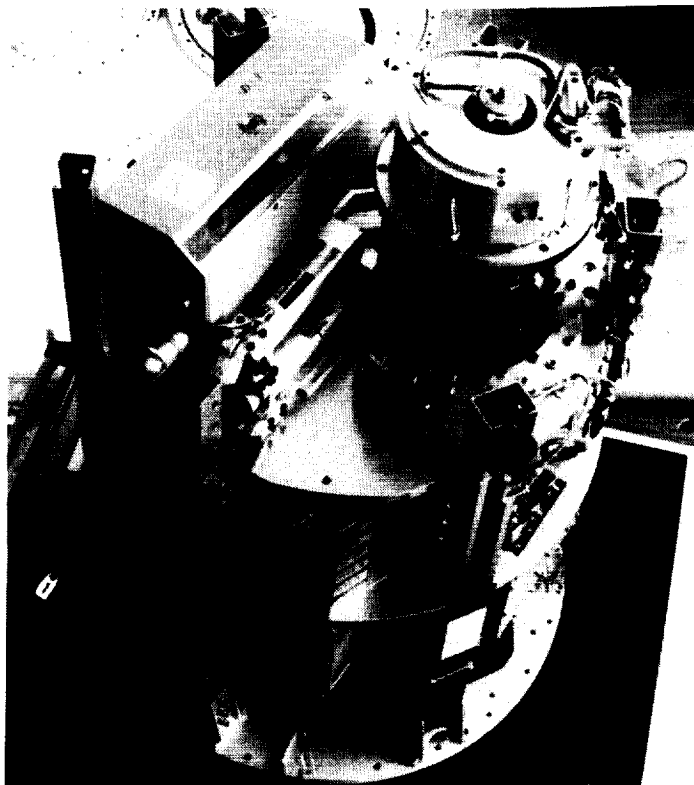

Fig. 2-1: MAUS-Payload DG 302

ORIGINAL PAGE IS
OF POOR QUALITY

A cylindrical floating zone is formed between two coaxial discs which can individually be rotated by two electric motors. The discs are in contact with each other before the silicone oil is injected by retracting one of the discs. The test liquid enters into the gap between the two discs through a central hole in the retracting disc. At any axial location, sufficient test liquid is injected to form a cylindrical floating zone.

Convection is made visible by small particles dispersed in the silicone oil. An optical plane generated by a He-Ne Laser assembly illuminates the particles on the meridian plane of the floating zone. This "light-section" technique enables motion pictures of two dimensional velocity components to be taken. The resulting film will show the onset of the Marangoni convection phenomenon, and the mass transport effects which it causes.

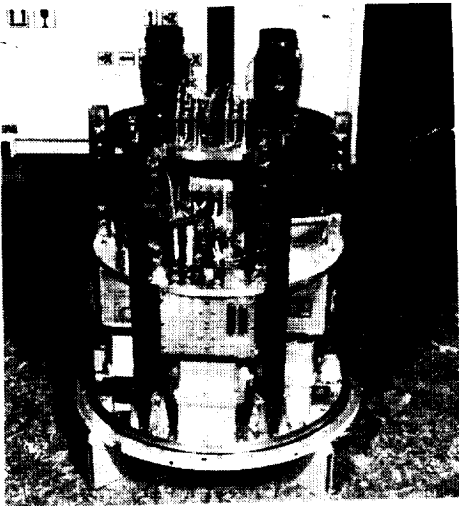

Fig. 2-2: MAUS-Payload DG 321

In MAUS experiment DG 321 two experiment chambers with zones of different length are mounted on the upper experiment platform and operated simultaneously. The floating zone is established by melting a solid NaNO_3 -cylinder between two graphite pistons. The liquid zone is held in position by surface tension forces. The graphite pistons are screwed into resistance heaters mounted in the housing of the hermetically sealed experiment chambers.

Thermocouples are used to control the temperatures of the heaters and of the pistons. A second thermocouple records the temperature oscillations in the liquid zone. The signals of the thermocouples as well as the heater currents are fed to the MAUS data acquisition system.

MAUS-Payload DG 504 has been described in detail during the 1987 GAS Symposium, (Ref. 2) therefore only the experiment cell is presented here.

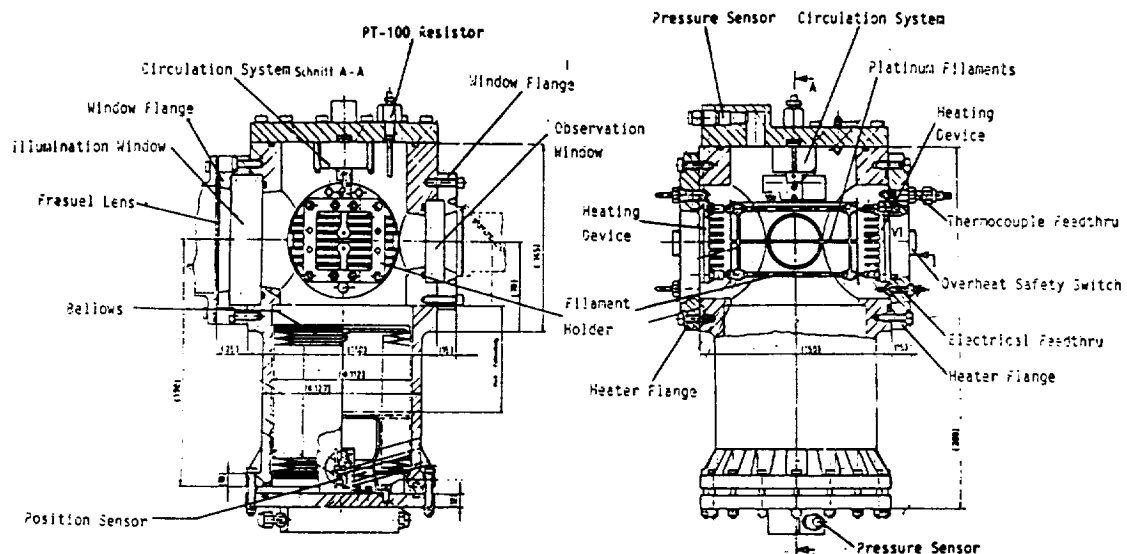

Fig. 2-3: Experiment Cell DG 504

A test liquid Freon R12 is contained in the experiment cell the basic geometry of which is a cube, having three cylindrical hollow spaces perpendicular to each other. Each of them is closed by two opposite flanges. A cylindrical extension contains a bellows which can be filled with nitrogen gas to achieve the desired pressure values. Windows on opposite sides of the cube allow for illumination and optical observation. Two heating devices are installed on the inside of the remaining two opposite flanges. Additionally, the liquid can also be circulated by a rotating paddle mounted on the upper flange. Two platinum filaments are mounted on an exchangeable filament holder. Eight thermocouples provide for temperature monitoring capability at different locations within the experiment cell. The Freon temperature is measured and controlled by a PT-100 sensor. The pressure of the nitrogen gas and of the Freon will both be monitored and controlled by piezoresistive absolute pressure transducers. To prevent overheating an overheat safety switch is mounted in good thermal contact on each of the heater flanges.

Other subsystems needed to operate this payload are the Freon expansion container, the pressure system, the optical system, and the interface electronics.

MAUS experiment DG 324 will be carried out to expand the data of experiment DG 318, successfully performed on STS-11. The same experiment configuration will be used, but with a different experiment profile (higher temperature, longer duration). The cylindrical glass sample (74 SiO_2 , 16 CaO - $10 \text{ Na}_2\text{O}$) with an artificial helium bubble at its center is held by a platinum tube which is closed by transparent sapphire windows. The furnace has an opening at either end, one for illuminating the bubble by a flashlight and the other for taking photographs.

The temperature of the sample will reach 1300°C during operation. A thermal analysis showed that only the integration of heatpipes can provide the needed heat flux to achieve a reasonable temperature distribution within the container.

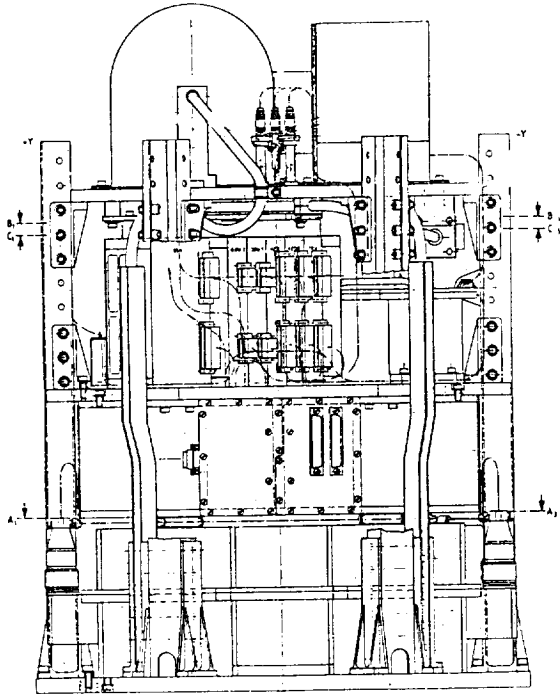

ORIGINAL PAGE IS
OF POOR QUALITY

Fig. 2-4: MAUS-Payload DG 324 with Heatpipes

Three heat pipes are directly coupled to the upper experiment platform on which the furnace is mounted. The opposite ends of the heatpipes are screwed to the brackets which connect the posts to the adapter ring. These modified brackets provide a larger contact area to the heatpipes as well as to the adapter ring, and assure adequate thermal conductance to the GAS container top plate, from which the heat will be radiated to space.

3. Improvements to the MAUS Standard System

The hitherto existing standard electronics for experiment control and data acquisition were developed almost ten years ago, but are now out-of-date and no longer suit the requirements of the experimenters, especially considering data resolution (10 bit) and data evaluation (Ref. 3). Four units of a new experiment control and data management system, based on an existing MBB-ERNO design, will be available to the MAUS project this year. To avoid changes in the existing experiment accommodation the modules will be housed in the existing casing. In its basic configuration the system will only consist of three modules, two for experiment control and data acquisition, and one for data storage. Additionally, a dc/dc converter replacing the electronic batteries will be included in the housing.

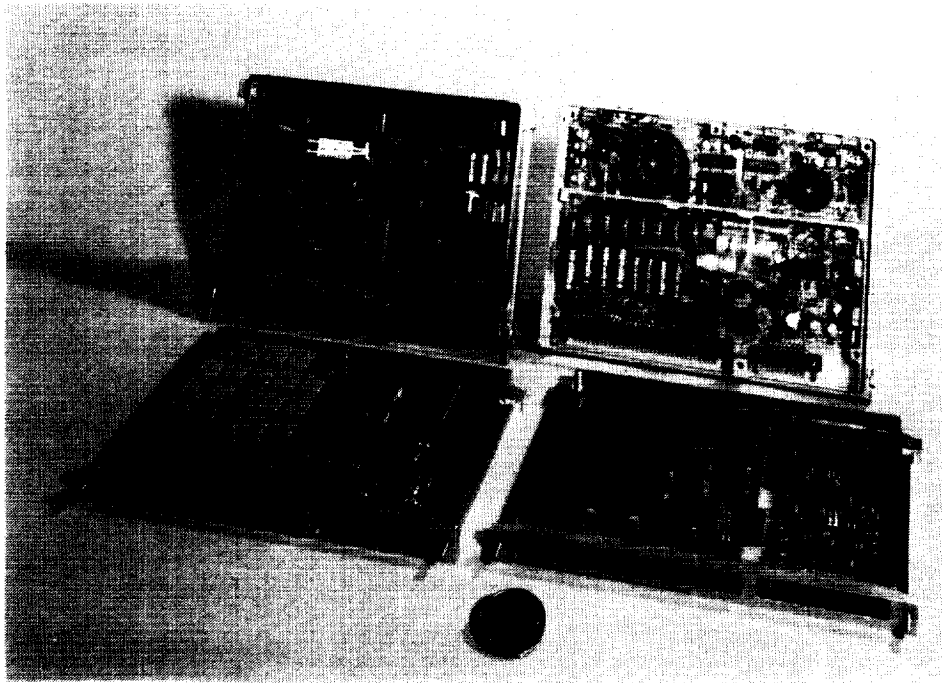

Fig. 3-1: Modules for Experiment Control, Data Management and Storage

Among other features this system allows for higher resolution (12 bit), higher data acquisition rates and easy data evaluation. Due to standard interfaces a PC can be used as EGSE. Data storage will be performed by a semiconductor memory with a basic storage capacity of 10 Mbit. This capacity can easily be expanded in steps of 20 Mbit. Also the number of digital and analog I/D's can be increased or adapted to the needs of a particular experiment. Generally, this new system is much more flexible in use.

4. TWIN-MAUS Configuration

A concept for the extension of MAUS payload resource limits has recently been analysed in the TWIN-MAUS (Two-Interconnected MAUS-Payloads) study. Generally in the existing MAUS system the resources are limited with respect to energy, volume/mass, experiment duration, heat dissipation, and data storage capacity.

The currently developed EURECA experiment HPT (High-Precision-Thermostat) has been chosen as a model payload because it is a rather complex experiment accommodated in a GAS canister with a modified MAUS experiment mounting structure and a modified end plate being used as a radiator. The HPT is an almost autonomous facility providing its own experiment control and data acquisition system. Fluid physics experiments can be carried out within precisely defined temperature ranges.

ORIGINAL PAGE IS
OF POOR QUALITY

The resource requirements of the model payload for a typical five day mission have been compared to resources offered by the MAUS system. The energy needed is about 10 kWh and approximately 100 Mbit of data will be generated, both depending on the actual experiment. The facility occupies the whole volume of a standard 5ft. GAS-canister.

To operate an experiment with resource requirements like the HPT, the GAS program offers the possibility of interconnection of GAS-canisters. An appropriate concept has been defined and analysed.

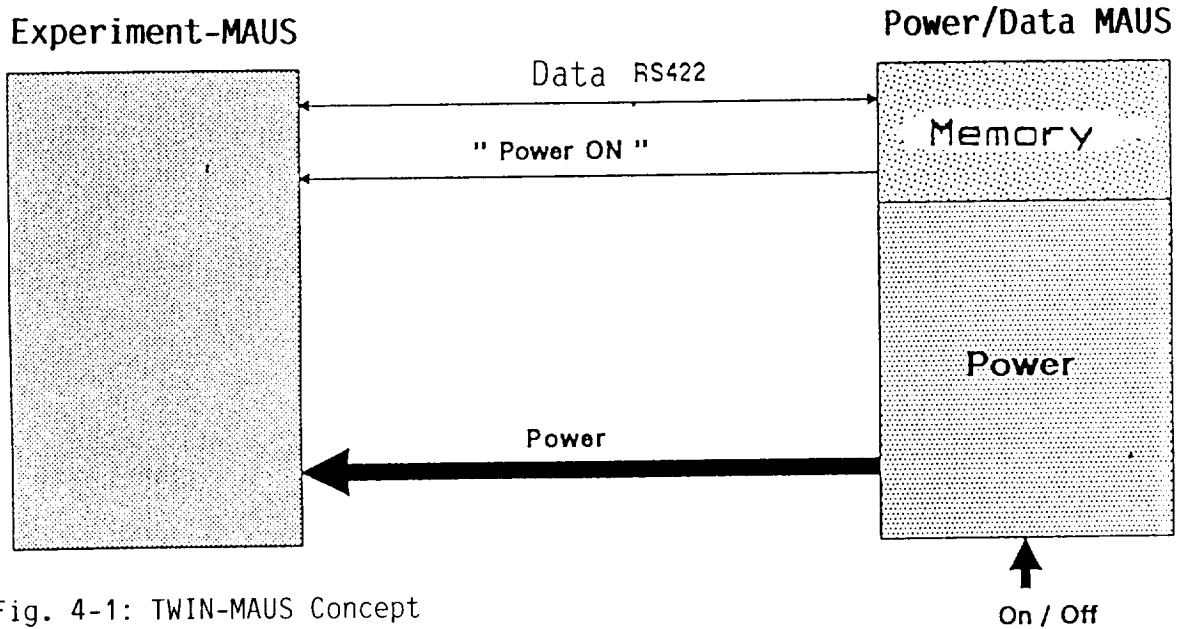

Fig. 4-1: TWIN-MAUS Concept

One canister contains just the experiment, in this case the HPT with its own experiment control and data acquisition unit. In the other container, the needed batteries, a power distribution unit, and a data memory unit are accommodated. All electronics are compatible with or even identical to the new MAUS electronics.

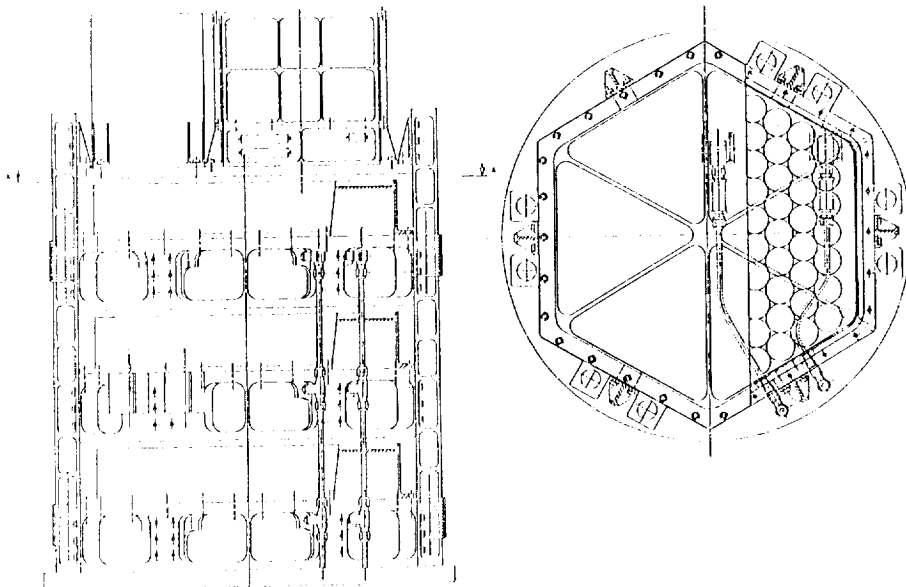

Fig. 4.2 Power/Data MAUS Design

The structural design of the Power/Data-MAUS is completely different from the existing MAUS hardware. Due to the limits of mass and load capacity the experiment mounting structure as well as the battery housing can no longer be used. A new self supporting battery housing has been designed. Up to three can be assembled in the Power/Data-MAUS by means of triangular shaped posts. Each of the batteries can be equipped with 180 Li SO₂ cells producing a total energy of 10.5 kWh. The two electronic units are mounted on a platform above the batteries.

A thermal analysis has been performed considering the TWIN-MAUS configuration. It turned out that all components of the Power/Data-MAUS were within their temperature limits independent of the orbiter thermal attitudes. For the HPT having a power dissipation of 90 W it turned out that a passive thermal control concept is only possible by avoiding hot thermal attitudes. Due to the necessary emission characteristics of the top plate deep space orientations (cold case) have to be limited to 7 hours.

As a rough reference value for other experiments, the thermal analysis showed, that with a maximal power consumption of approximately 75 watts a continuous operation during the whole shuttle mission will be possible. But to get more precise values a detailed thermal analysis is necessary for each particular payload.

As a further aspect of the study the possibility of flying experiments like the HPT in GAS-canisters on the carriers Hitchhiker-G, -M, and DOM (a German payload carrier system), was examined. Only one container will be used in that configuration, the resources of the Power/Data-MAUS being provided by the carriers. All carriers offer up- and downlink capabilities, additionally the DOM carrier offers active cooling by a Freon cooling loop. Looking at cost and availability aspects, the TWIN-MAUS configuration offers the most promising possibility to meet the challenge of future advanced payloads.

References:

1. G.H. Otto: Experimental Results from Automated MAUS Payloads. IAF Paper No. 88-351 (1988).
2. S. Staniek, G. Otto and J. Döpkins: Ten Past and Ten Future GAS/MAUS Payloads. NASA CP-2438, pp. 31-38 (1987).
3. D. Baum, G. Otto and P. Vits: MAUS-A Flight Opportunity for Automated Experiments Under Microgravity Conditions. Acta Astronautica, Vol. 11, pp. 239-245 (1984).