

JPL-11-100-53-01R
166955
92P.

JPL Publication 88-26

The State of the Art of dc Power Distribution Systems/Components for Space Applications

S. Krauthamer

(NASA-CR-182743) THE STATE-OF-THE-ART OF dc
POWER DISTRIBUTION SYSTEMS/COMPONENTS FOR
SPACE APPLICATIONS (Jet Propulsion Lab.)
92 p CSDL 10B

N89-10941

Unclas
0166955

G3/20

July 1988



National Aeronautics and
Space Administration

Jet Propulsion Laboratory
California Institute of Technology
Pasadena, California



JPL Publication 88-26

The State of the Art of dc Power Distribution Systems/Components for Space Applications

S. Krauthamer

July 1988



National Aeronautics and
Space Administration

Jet Propulsion Laboratory
California Institute of Technology
Pasadena, California

The research described in this publication was carried out by the Jet Propulsion Laboratory, California Institute of Technology, under a contract with the National Aeronautics and Space Administration.

Reference herein to any specific commercial product, process, or service by trade name, trademark, manufacturer, or otherwise, does not constitute or imply its endorsement by the United States Government or the Jet Propulsion Laboratory, California Institute of Technology.

ABSTRACT

This report is a survey of the state of the art of high voltage dc systems and components. This information can be used for consideration of an alternative secondary distribution (120 Vdc) system for the Space Station. All HVdc components have been prototyped or developed for terrestrial, aircraft, and space applications, and are applicable for space application with appropriate modification and qualification. HVdc systems offer a safe, reliable, low mass, high efficiency and low EMI alternative for Space Station secondary distribution.

ACKNOWLEDGMENTS

This work was done for the Program Studies Division, Program Requirements and Assessment Office of the NASA Space Station Level II Organization.

The contribution of the following individuals at JPL is acknowledged. Linda Palmieri provided the inputs for Chapter 10. John Klein, Radhe Das, and Albert Whittlesey reviewed the document and provided helpful critiques. Elly Hardy and Esther Graham did an excellent typing job; Pat South was the document editor.

S. Ćuk of the Power Electronics Group at the California Institute of Technology provided the inputs on the State of the Art of dc/dc Converter, which is included in Appendix C.

Many individuals and organizations provided valuable information regarding their activities in high voltage dc distribution systems and components. The names of the organizations providing information are listed in Appendix A.

Ed White and Bob Digirolano of the Naval Air Development Center provided extensive technical information reflecting their pioneering work on High Voltage dc Electrical Distribution Systems for Advance Aircraft.

Don Teague of the Space Station Program Office provided the relevant data from the European Space Agency (ESA) and the National Space Development Agency of Japan. Thanks are due to all these individuals and organizations.

Mukund Gangal
Technical Manager
Program Studies Div.

Stan Krauthamer
Member Technical Staff
Power Electronics Group
Jet Propulsion Laboratory

Robert Edelson
Director
Program Studies Div.
Program Requirements and
Assessments Office
NASA Space Station

PRECEDING PAGE BLANK NOT FILMED

ABBREVIATIONS AND ACRONYMS

A	amperes
ac	alternating current
ALPHA	Represents the gimbal through which power is transmitted
BDC	Bidirectional Converter
BETA	Represents the gimbal through which power is transmitted
CSD	Constant Speed Drive
dc	direct current
DCSU	Direct Current Switching Unit
di/dt	Change of current with respect to time
DSVRS	Deep Sea Research Vehicle
EMI	Electromagnetic Interference
ENG	Engine
EPS	Electric Power System
ESA	European Space Agency
GCU	Generator Control Unit
GVR	Generator Voltage Regulator
h	hours
HVIC	High Voltage Integrated Circuit
HVdc	High Voltage dc (100-300 Vdc)
Hz	hertz
IGBT	Insulated Gate Bipolar Transistor
IOC	Integrated Operations Configuration
JEM	Japan Experimental Module
kHz	kilohertz
kW	kilowatts
LVdc	Low Voltage dc (Below 100 Vdc) - NASA Std. 28 Vdc
MBSU	Main Bus Switching Unit
MCT	Metal Oxide Silicon Controlled Thyristor
MHz	Megahertz
MIL-STD	Military Standard
MILSTAR	Military Strategic Tactical Relay
MIU	Main Inverter Unit
MOSFET	Metal Oxide Field Effect Transistor
ms	millisecond
μs	microsecond
MTBF	Mean Time Between Failure
NADC	Naval Air Development Center
NASA	National Aeronautics and Space Administration
NASDA	National Space Development Agency of Japan
NM	Nautical Miles
NPCU	Node Power Control Unit
NSTS	National Space Transportation System
NSU	Node Switching Unit
PDA	Power Distribution Assembly
PDCA	Power Distribution and Control Assembly
PDCU	Power Distribution and Control Unit
PDCU Module	Power Distribution and Control Unit in the module
PMAD	Power Management and Distribution
POP	Polar Orbiting Platform
PPS	Power Processor Subsystem
PV	Photovoltaic

PWM	Pulse Width Modulation
RBI	Remote Bus Isolator (interrupter)
REC	Rectifier
RPC	Remote Power Controller
RTG	Radioisotope Thermal Electric Generator
s	second
SAE	Society of Automotive Engineers
SASU	Solar Array Switching Unit
SOC	State of Charge
SPST	Single Pole Single Throw
SS	Space Station
STC-DBS	Satellite Television Corp. - Direct Broadcast System, RCA (GE) Astro-Electronics
TU	Transformer Unit
TWT	Traveling Wave Tube
Vdc	Volts dc
VF	Variable Frequency
VT	Voltage-Temperature
W	Watts
W/in ³	Power Density - watts/cubic inches

CONTENTS

	EXECUTIVE SUMMARY	ES-1
1.	INTRODUCTION	1-1
	1.1 DESCRIPTION OF BASELINE SPACE STATION POWER SYSTEM	1-1
	1.2 ALTERNATE SECONDARY POWER DISTRIBUTION SYSTEM	1-1
	1.3 DESIRED CHARACTERISTICS OF A SECONDARY DISTRIBUTION SYSTEM	1-5
	1.4 SUMMARY	1-6
2.	BACKGROUND	2-1
	2.1 SECONDARY POWER DISTRIBUTION CONSIDERATIONS	2-1
	2.2 dc EXPERIENCE ON AMERICAN SPACECRAFT	2-1
	2.3 SYNERGISTIC DEVELOPMENT	2-5
	2.3.1 100 Vdc Spacecraft Bus	2-5
	2.3.2 270 Vdc Bus Electrical Systems for Aircraft	2-5
	2.3.3 High Voltage dc Bus Electrical Systems for Submarines	2-8
	2.3.4 270 Vdc Bus Electrical Systems for Tanks.	2-8
3.	SPACECRAFT HIGH VOLTAGE dc SYSTEM TOPOLOGY	3-1
	3.1 SPACE STATION SECONDARY DISTRIBUTION	3-1
	3.2 PLATFORM POWER DISTRIBUTION	3-2
4.	SPACECRAFT COMPONENT CONSIDERATIONS FOR HIGH VOLTAGE DC SYSTEMS	4-1
	4.1 APPLICATION CONSIDERATIONS	4-1
	4.2 REMOTE BUS ISOLATOR (RBI)	4-2
	4.3 REMOTE POWER CONTROLLERS (RPCs)	4-2
	4.4 POWER CONDITIONERS	4-3
	4.5 ac MOTOR DRIVES	4-3

4.6	dc BUS REGULATOR	4-4
4.7	CURRENT SENSORS/GROUND FAULT SENSORS	4-4
5.	COMPONENTS TO IMPLEMENT AN HVdc DISTRIBUTION SYSTEM	5-1
5.1	REMOTE BUS ISOLATORS (RBIs)	5-1
5.1.1	Contactors	5-1
5.1.2	Hybrid Power Interrupters	5-2
5.1.3	Solid State Power Interrupters (RBI)	5-4
5.2	REMOTE POWER CONTROLLERS (RPCs)	5-8
5.3	POWER CONDITIONERS	5-8
5.4	dc BUS REGULATOR	5-13
5.5	ac MOTOR DRIVES	5-13
5.6	SENSORS	5-17
5.6.1	Current Sensors	5-17
5.6.2	Ground Fault Sensors	5-18
6.	FLAT CABLE IN ELECTRICAL POWER DISTRIBUTION SYSTEMS	6-1
7.	RELIABILITY	7-1
8.	EMI CONSIDERATIONS	8-1
9.	SAFETY CONSIDERATIONS IN HIGH VOLTAGE dc SYSTEMS	9-1
10.	POWER MANAGEMENT AND DISTRIBUTION (PMAD) CONTROL SYSTEM	10-1
10.1	LOW VOLTAGE dc SPACECRAFT	10-1
10.2	POWER GENERATION AND STORAGE	10-1
10.3	POWER REGULATION AND DISTRIBUTION	10-3
10.4	MICROPROCESSOR FUNCTIONS	10-3
10.5	CONCLUSIONS	10-5

11.	CONCLUSIONS	11-1
12.	REFERENCES	12-1
13.	BIBLIOGRAPHY	13-1

APPENDIXES

A.	ORGANIZATIONS INVOLVED IN HVdc COMPONENTS/SYSTEMS	A-1
B.	POWER CONTROLLER EFFICIENCY DATA COMPARISON	B-1
C.	STATE-OF-THE-ART TECHNOLOGY IN dc/dc CONVERTERS	C-1

Figures

1-1.	Space Station Configuration	1-2
1-2.	Space Station Electric Power System Functional Block Diagram	1-3
1-3.	SS Manned Core Loads	1-4
2-1.	Power and Voltage of Various Spacecraft (Flight Hardware and Developmental Spacecraft)	2-4
2-2.	Simplified EPS Block Diagram RCA - (STC-DBS)	2-6
2-3a.	Existing Aircraft Electric Power System	2-7
2-3b.	Proposed Advanced Aircraft Electric Power System	2-7
3-1.	Space Station Baseline Power System Block Diagram	3-1
3-2.	Space Station Secondary Power Distribution, HVdc Option	3-2
3-3.	Free Flyer Platform Power Distribution (Space Station Baseline 20 kHz ac)	3-2
3-4.	Free Flyer Platform Power Distribution (HVdc Alternative to Space Station Baseline)	3-3
5-1.	Functional Block Diagram of Hybrid Interrupter.	5-3
5-2.	Hybrid Power Interrupter Block Diagram	5-3
5-3.	Typical Solid-State Power Interrupter Block Diagram	5-6
5-4.	RBI Trip Characteristic	5-6

5-5.	Trip Characteristics for RPC	5-11
5-6.	TESLaco 100 W, 270 V to 5 V Switching Power Supply	5-12
5-7.	Boeing Electronics Company 50 W, 28 V to 5 V dc-to-dc Converter Hybridized	5-12
5-8.	dc Bus Regulator (buck type)	5-14
5-9.	Basic Inverter Circuit Diagram	5-16
5-10.	Integrated Actuator System	5-17
10-1.	PPS Functional Block Diagram	10-2
10-2.	Hybrid Switch Block Diagram	10-4

Tables

1-1.	Space Station Load Mix	1-5
2-1.	Spacecraft Bus Voltage Summary	2-2
3-1.	Secondary Power Distribution Components	3-3
4-1.	High Voltage dc Distribution Systems Design Objectives	4-1
5-1.	High Voltage dc Contactors	5-2
5-2.	270 Vdc Hybrid Power Interrupters (RBI)	5-4
5-3.	Solid-State Power Interrupters (RBI)	5-5
5-4.	Remote Power Controllers (RPC)	5-9
5-5.	Power Conditioners (dc/dc Converters)	5-11
5-6.	Characteristics of dc Bus Regulators	5-15
5-7.	ac Motor Drives	5-15
5-8.	dc Isolated Current Sensors	5-18
7-1.	Component Reliability	7-1
9-1.	Effect of Electrical Currents on Cells and Tissue	9-1
10-1.	Power/Pyro Subsystem - Software Code Estimates	10-6

EXECUTIVE SUMMARY

HIGH VOLTAGE dc (HVdc)* POWER FOR SPACECRAFT

This report is a survey of the state of the art of HVdc systems and components. This information can be used for consideration of an alternate secondary distribution system (120 to 160 Vdc) for the Space Station (SS), and for platforms. The Space Station requires substantially more power than any previous space mission; therefore, previously developed low voltage (28 to 42 Vdc) systems are not practical, due to mass and efficiency considerations.

The SS baseline specifications call for a 20 kHz primary and secondary distribution system. One hundred and sixty Vdc, generated by photovoltaics and stored in the batteries, will be inverted to single phase, 440 Vac, 20 kHz for primary distribution, then transformed to 208 Vac for secondary distribution, supplying up to 2000 loads on the 208 V bus (Figure ES-1).

Some users such as the European Space Agency (ESA) and the National Space Development Agency of Japan (NASDA) prefer to use 120 Vdc for secondary distribution. To implement such a system, the distribution voltage is selected within the constraints unique to the spacecraft environment including electrical discharge (corona), plasma effects, and parts rating. With these constraints a range of 120 to 160 Vdc appears to be practical, thus 120 Vdc has been selected, at this time, for consideration as secondary power distribution in the Space Station modules.

HVdc designs for spacecraft may take advantage of previous experience with HVdc systems for spacecraft, aircraft, tanks, and submarines, as well as commercial work for power supplies and controllers for computers and industrial controls. In addition, the control experience with lower voltage (28 to 42 V) dc (LVdc) spacecraft will be useful to the HVdc design. An example of a practical implementation of an HVdc spacecraft is the GE (RCA) STC-DBS spacecraft. This spacecraft uses a dual bus with one bus operating at 100 Vdc and a 2 kW power rating. This experience places the state of the art close to the Space Station platforms requirements.

All critical components for HVdc distribution and control have been developed for terrestrial and aerospace applications. European and Japanese spacecraft designers have proposed to use 120 Vdc distribution in their models because of the improved efficiency, lower levels of electromagnetic interference (EMI), and lower mass. The components for HVdc space power systems have been developed to a point where space environment related development and qualification can be undertaken.

ARCHITECTURE/TOPOLOGY

The proposed architecture for a high voltage dc power secondary distribution system for Space Station is shown in Figure ES-2. Key components shown in the figure include remote bus interrupters (RBIs) to interrupt the bus under the control of the power management and distribution (PMAD) system, remote power controller (RPC) power switches, motor drives, and dc/dc controllers. PMAD is not shown.

*100 to 300 Vdc

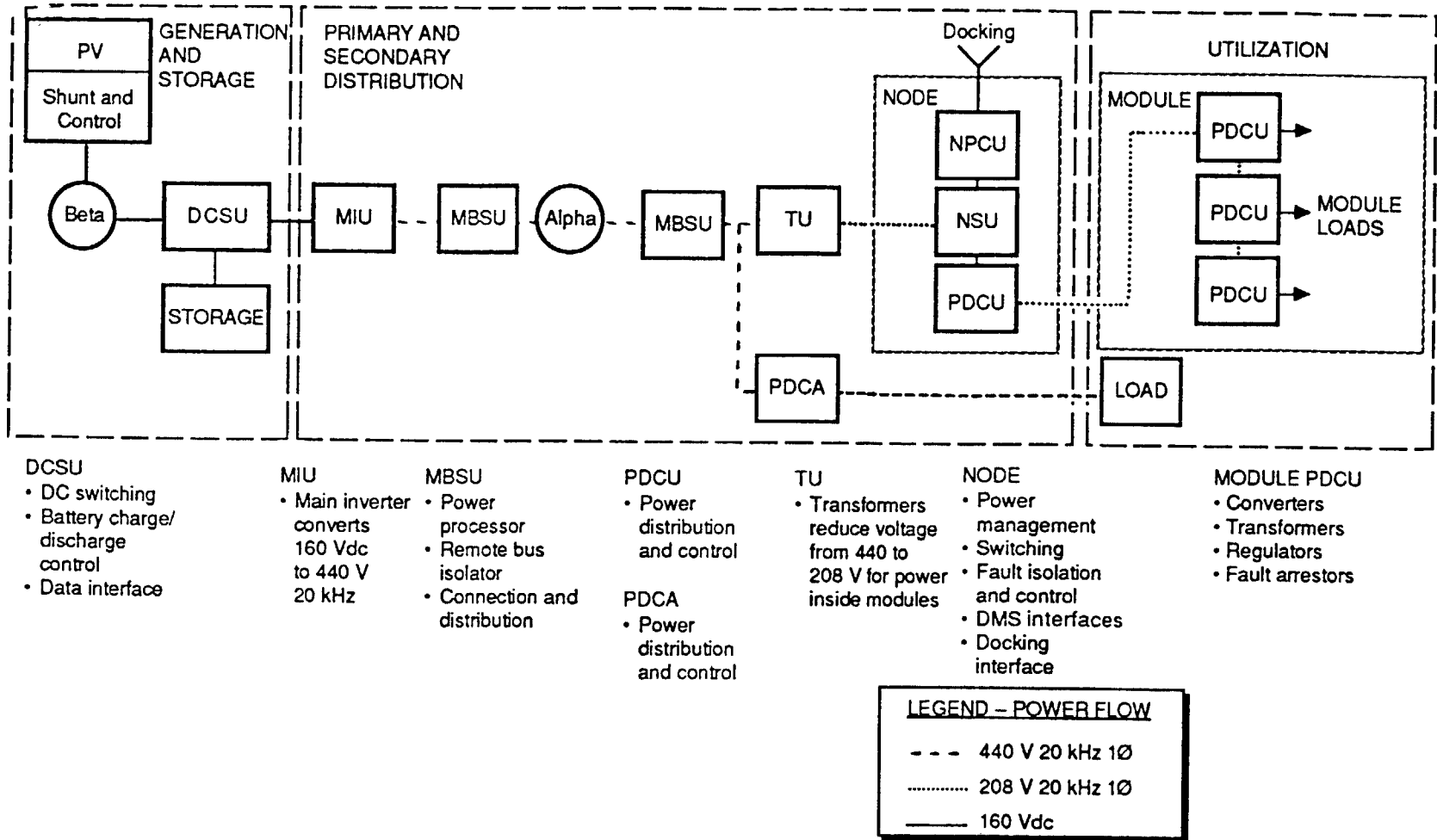

DCSU

- DC switching
- Battery charge/discharge control
- Data interface

MIU

- Main inverter converts 160 Vdc to 440 V 20 kHz

MBSU

- Power processor
- Remote bus isolator
- Connection and distribution

PDCU

- Power distribution and control

PDCA

- Power distribution and control

TU

- Transformers reduce voltage from 440 to 208 V for power inside modules

NODE

- Power management
- Switching
- Fault isolation and control
- DMS interfaces
- Docking interface

MODULE PDCU

- Converters
- Transformers
- Regulators
- Fault arrestors

Figure ES-1. Space Station Electric Power System Functional Block Diagram

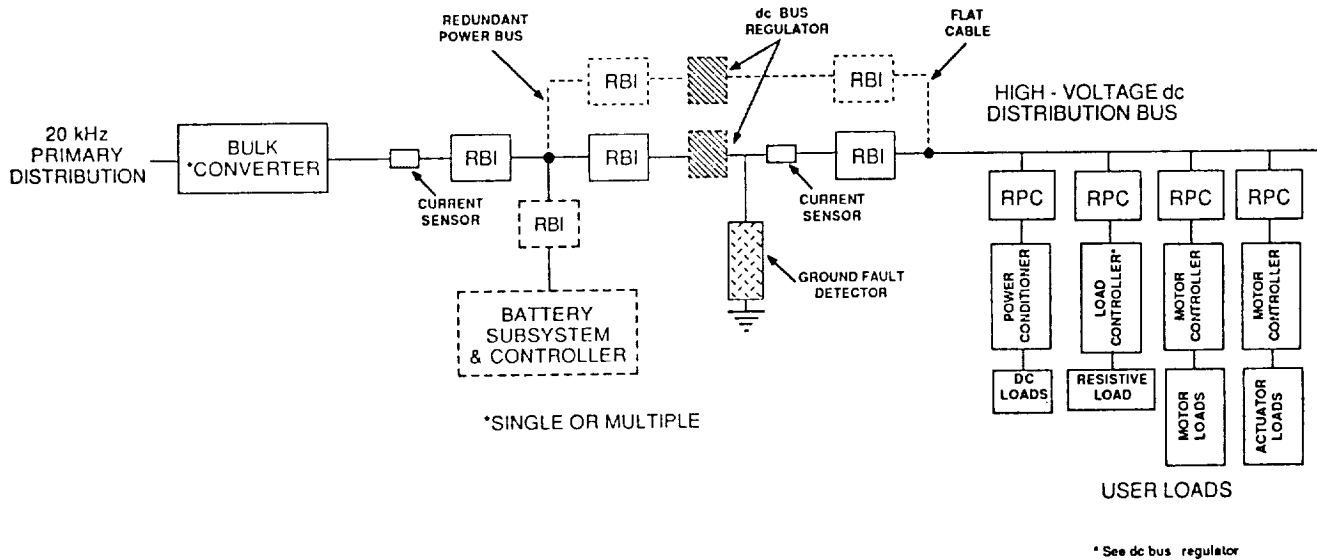

Figure ES-2. SS Secondary Power Distribution, HVdc Option

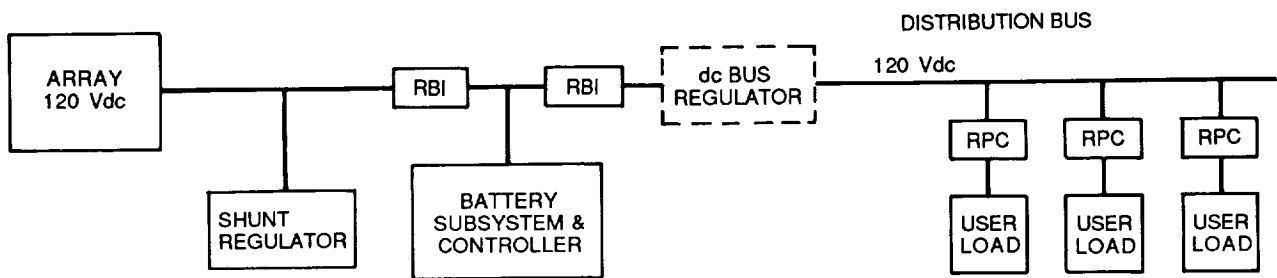

Figure ES-3. Free Flyer Platform Power Distribution (HVdc)

The power distribution HVdc option for the platform is shown in Figure ES-3. A dc bus regulator is shown in Figure ES-3 and may be used if the dc bus (120 Vdc) is lower than the array platform voltage.

SPECIFIC COMPONENTS

Various components to implement an HVdc secondary distribution system are shown in Table ES-1 and Figure ES-2. Components such as batteries and photovoltaic arrays are beyond the scope of this report.

Remote Bus Interrupters (RBI)

Remote bus interrupters (RBIs) are remotely operated devices for the connection and interruption of secondary power distribution. They are controlled by a central power management and distribution (PMAD) system. Interruption allows routing of power to loads as required and protects against faults and overloads. Remote bus interrupters are of three classes: electromechanical contactors, solid-state interrupters, and hybrids.

Table ES-1. Secondary Power Distribution Components

Component	Comments
Flat cable	See Section 6
Power conditioners	dc/dc converters (electrical isolation)
Load controllers	Resistive load control (dc/dc converter, none isolated)
ac Motor drives	Inverters (including brushless dc motor control)
Ground fault detector	Senses bus to ground faults
Current sensors	Electrically isolated dc current sensors
Remote bus isolators (RBI)	Solid state switch for power bus control
Remote power controllers (RPC)	Solid state switch for load control
	switching

Electromechanical Contractors

HVdc contactors are produced by Hartman Electric Co. and Eaton Corp., Cutler Hammer Division. Models produced are 5 types and 1 type respectively. Sizes range from 15 in³ and 12 oz, to 150 in³ and 7 lb. Various models are current rated between 80 A and 650 A.

Hybrid Power Interrupters

Hybrid interrupters incorporate electromechanical contactors with solid state devices across the contacts. Four models are produced by Lockheed Advanced Marine Systems, Westinghouse, Teledyne Kinetics Division and Eaton Corp., Cutler Hammer Division, ranging in size from 30 in³ and 12 oz, to 512 in³ and 14 lb. Various models are rated for currents between 80 A and 400 A.

Solid State Power Controllers

Solid state power controllers have switching times ranging between 1 μ s and 2 ms. Current limits may be preset or variable. Switching life is several orders of magnitude greater than contactors or circuit breakers. Capabilities which may be designed into a solid state power controller are built-in diagnostics, MIL-STD-1553B Data Bus Interface, status feedback, bidirectional current limiting and operation, as well as limits on the rate of rise and fall of overload current (di/dt). These devices may also match I²t characteristics to system cables, and monitor current level and leakage. Two models are produced by Westinghouse and Lockheed Advanced Marine Systems. One device is 863 in³ and 15 lb. The other is an integral part of an undersea vehicle. Current ratings range from 117 A to 150 A.

Remote Power Controllers (RPC)

Remote power controllers are devices which replace conventional electromechanical relays in the 1 to 30 A range. They are similar in function to solid state power controllers (RBI). Mass, volume, efficiency and switching life are of critical importance. Some significant characteristics are: a controlled rate of current rise and fall, short circuit protection, current limiting to prevent load transients, wide temperature range, electrical isolation of control and status signals from the power bus, high speed trip-out response characteristics, diagnostic capability. Teledyne Solid State, Leach Relay, Rockwell, Kilovac, and Westinghouse produce 20 models of RPCs. Sizes range from a 0.15 in³ hybrid, to a unit 16.5 in³ weighing 14 oz.

HVdc dc/dc Power Conditioners

High voltage dc/dc power conditioners for spacecraft are available in the 100- to 300-V range. These power conditioners are available with efficiencies from 85 percent at 5 V to 90 percent at 15 V and 95 percent above 100 V. Off-line, high efficiency power conditioners are well characterized, and the techniques of their design are applicable to HVdc spacecraft power conditioner design. Frequencies >400 kHz allow reductions in power supply mass and volume. These low mass converters allow the use of multiple power supplies, located at point-of-use. Experience with LVdc spacecraft devices may also be applied. Three models are available from TESLaco, Inland Motor, and Space Power Inc. Sizes range from 3 to 167 in³, and power densities range from 30 to 300 W/in³.

ac Motor Drives

The ac motor drives are required to provide appropriate voltage and frequency to a motor load such as an actuator on a large spacecraft. They also effect conversion of source energy to single- and three-phase power. Waveform synthesized, pulse width modulated (PWM) inverter-type motor drives are used extensively in commercial, military, and spacecraft applications. These inverters are noted for their bilateral characteristics (energy may be fed to the motor or returned to the source). These inverters are noted for their high efficiency and their minimum usage of power semiconductors. The efficiency range of these motor controllers is 92 to 97.5 percent, and their masses are low. Three different models have been built by Aeroenvironment Inc., General Electric, and JPL. Sizes range from 96 in³ and 8 lb, to 1152 in³ and 42 lb, while ratings vary from 5 to 35 kW.

HVdc Bus Regulators

The dc bus regulators not only control voltage, but can also act as dc/dc transformers. These HVdc bus regulators can regulate the spacecraft dc bus, provide regulated and adjustable voltage to a heater load, and may be used as charge/discharge controllers for a battery subsystem. They provide an interface between a source voltage and that of a secondary power distribution

bus. There are 2 models of dc bus regulators from Aeroenvironment Inc. and Space Power Inc. They span a weight range of 0.6 lb to 5 lb, and range in power rating from 150 W to 20 kW. Efficiency ranges from 98.5 percent to 95 percent.

Sensors

Sensors of two types are examined. Current sensors are required for dc bus current monitoring and sensing for protective devices. Ground fault sensors identify faults between the power bus and the spacecraft. Three manufacturers of dc isolated current sensors offer three models; the smallest device being 0.326 in³ and 0.75 oz, and the largest being 2.55 in³ and 1.3 oz. Current ratings vary between 1 A and 1000 A.

Such devices have been used in terrestrial photovoltaic systems and other military applications.

Flat Cables

Replacement of round wire with flat cable can reduce cable mass by 40 percent and reduce temperature rise. Such cable is now available to meet spacecraft requirements.

SYSTEM DESIGN CONSIDERATIONS

Reliability

High reliability is a major requirement of an HVdc secondary distribution system. Since the high voltage dc spacecraft secondary distribution bus has similarity with its low voltage counterparts and HVdc aircraft, it can be expected that by using the same ground rules of design, reliability will be equivalent or better.

Because of the limited production of HVdc components, mean time between failure (MTBF) data is limited in availability. Available data for HVdc components is shown in Table ES-2.

Table ES-2. Component Reliability

HVdc Components	Reliability Characteristics
Solid State Switches	10^5 - 3×10^5 Switching Cycles
Hybrid Switches	10^4 - 5×10^4 Switching Cycles
Power Conditioners	10^5 MTBF (h)

EMI Considerations

EMI levels that meet standards such as MIL-STD-461B help assure trouble-free spacecraft operation.

MIL-STD-461B specifies allowable current levels over a frequency band. It can be inferred that the conducted ripple current level of a power conditioner operating at 28 Vdc and 1 kW, will be similar to a 4.5 kW power conditioner at 126 Vdc. This is because the bus current and the power switches in the power conditioner will process similar current levels. Ripple voltages on the spacecraft bus will be higher because the bus source impedance will rise at approximately the same ratio as the voltage. Ripple voltage as a percentage of dc bus voltage will remain the same. If additional ripple voltage reduction is required, additional filtering can be added. With the usage of flat dc bus cable, which represents itself as a transmission line, additional conducted EMI suppression is provided due to the cable distributed capacitance. The issue of whether the radiated noise from the power conditioner will meet MIL-STD-461B is not known at this time, but the techniques of suppression should be similar to that used in the lower voltage designs. Thus, the heritage of EMI control and the levels in HVdc systems are expected to be similar to the methods used in the LVdc counterparts.

SAFETY CONSIDERATIONS

Shock level is related to current passing through the body. Current is dependent on voltage level, body resistance, and frequency. Secondary distribution voltage level of 120 Vdc is sufficiently low and should not present a major hazard to personnel, when used in conjunction with ground fault sensors.

From a safety point of view, voltage and frequency do have an effect on perception and paralysis of humans. At similar voltage levels, the sensitivity to dc is approximately equivalent to that at 10 kHz. No unusual safety problems at the 120 Vdc level were reported in the literature. It should be noted that a 120 Vdc bus and a 20 kHz, 208 Vdc bus appear to be comparable with regard to shock hazard.

Power Management and Distribution

Power Management and Distribution is well developed for low voltage dc space applications which have applications in HVdc power management. Control of power sources, batteries, controllers, converters and remote load controllers is similar for both LVdc and HVdc, thus LVdc experience is applicable. The LVdc experience will also be directly applicable to the unmanned platforms. The control of a manned system is obviously more complex.

CONCLUSIONS

- o Current technology will allow the development of an HVdc secondary distribution system for space application.

- o A large number of vendors have the technology and space qualification background to produce the required components and design of HVdc systems competitively. RCA has built and qualified a spacecraft with a 100 Vdc bus.
- o All components to build HVdc systems have been prototyped or developed for terrestrial and aircraft applications. Previous deficiencies in dc switching have been resolved. Those HVdc components developed for aircraft applications are compact, low mass, high efficiency, and suitable for space environment development.
- o Qualification of most HVdc components for space applications is still required.
- o Because of the use of HVdc for array and battery subsystems, a number of HVdc components have already been developed for space applications, including brassboards for Space Station.
- o There exists a substantial 28 Vdc to 50 Vdc spacecraft experience in the design of power management and distribution (PMAD) control systems. The prototype developments using MIL-STD-1553B control bus for aerospace applications have paved the way for HVdc PMAD systems for space station applications.
- o The extensive space experience in low voltage dc design heritage allows the development of procedures and components for EMI control, system stability, and grounding for HVdc systems.
- o Safety issues relating to HVdc are well understood. No unusual safety problems were reported in the literature.
- o Users are familiar with design techniques and applications of dc/dc converters and dc power controls which simplify user interface.
- o The simplicity, low parts count, and previous space qualification history of dc systems offer the potential of high reliability for space environments.

SECTION 1

INTRODUCTION

1.1 DESCRIPTION OF BASELINE SPACE STATION POWER SYSTEM

The Space Station will require substantially more power than any previous space mission. A conceptual drawing of the Space Station configuration is shown in Figure 1-1. The design is baselined [1-1]* for 75 kW average capacity with provisions for growth scarring to 300 kW. The three elements of the Electric Power System (EPS) shown in Figure 1-2 are: power generation and storage, primary and secondary distribution, and utilization. Photovoltaic (PV) arrays, shunt regulation, battery charge/discharge controller, dc switching, and data interfaces are shown as the functional blocks in the generation and storage element. Batteries are used to store power for use during the eclipse period as well as during peak demand periods.

For a number of reasons, including mass considerations, the National Aeronautics and Space Administration (NASA) has decided to use 20 kHz frequency for primary and secondary distribution [1-2]. An inverter will invert 160 Vdc input from a photovoltaic array/battery subsystem to single phase, 440 V, 20 kHz alternating current (ac) for primary distribution. A transformer will step down the voltage to 208 Vac for secondary distribution. Users will plug into a 208 Vac bus and convert the power to the appropriate form and level.

There are a number of different types of loads connected to the EPS. Figure 1-3 shows a distribution of loads for housekeeping as well as for end user's applications. The important thing to note is that there may be as many as 2000, each requiring a mix of transformers, converters, regulators, fault isolators, and power factor correction reactors.

1.2 ALTERNATE SECONDARY POWER DISTRIBUTION SYSTEM

Some designers [1-3,1-4] would like to substitute a 120 Vdc system for the 208 Vac secondary distribution system in the modules. Voltages of 100 Vdc to 300 Vdc will be referred to as "high voltage" in this report. They claim that the use of High Voltage direct current (HVdc) in secondary distribution will improve efficiency, reduce mass, and reduce development risk. It is difficult to directly compare the ac versus dc approaches because there is little space experience with either system in the range of power required. Therefore, the purpose of this report is to survey the state of the art of HVdc systems and components, and to provide to the reader, up-to-date and comprehensive data.

A second issue involves the proliferation of dc throughout the Space Station. While distribution of the power will be ac, the primary source and regulation functions will be dc. In addition, it is anticipated that all emergency power will utilize dc components. And finally, the preponderance of

* Bracketed numbers indicate references listed in Section 12.

1-2

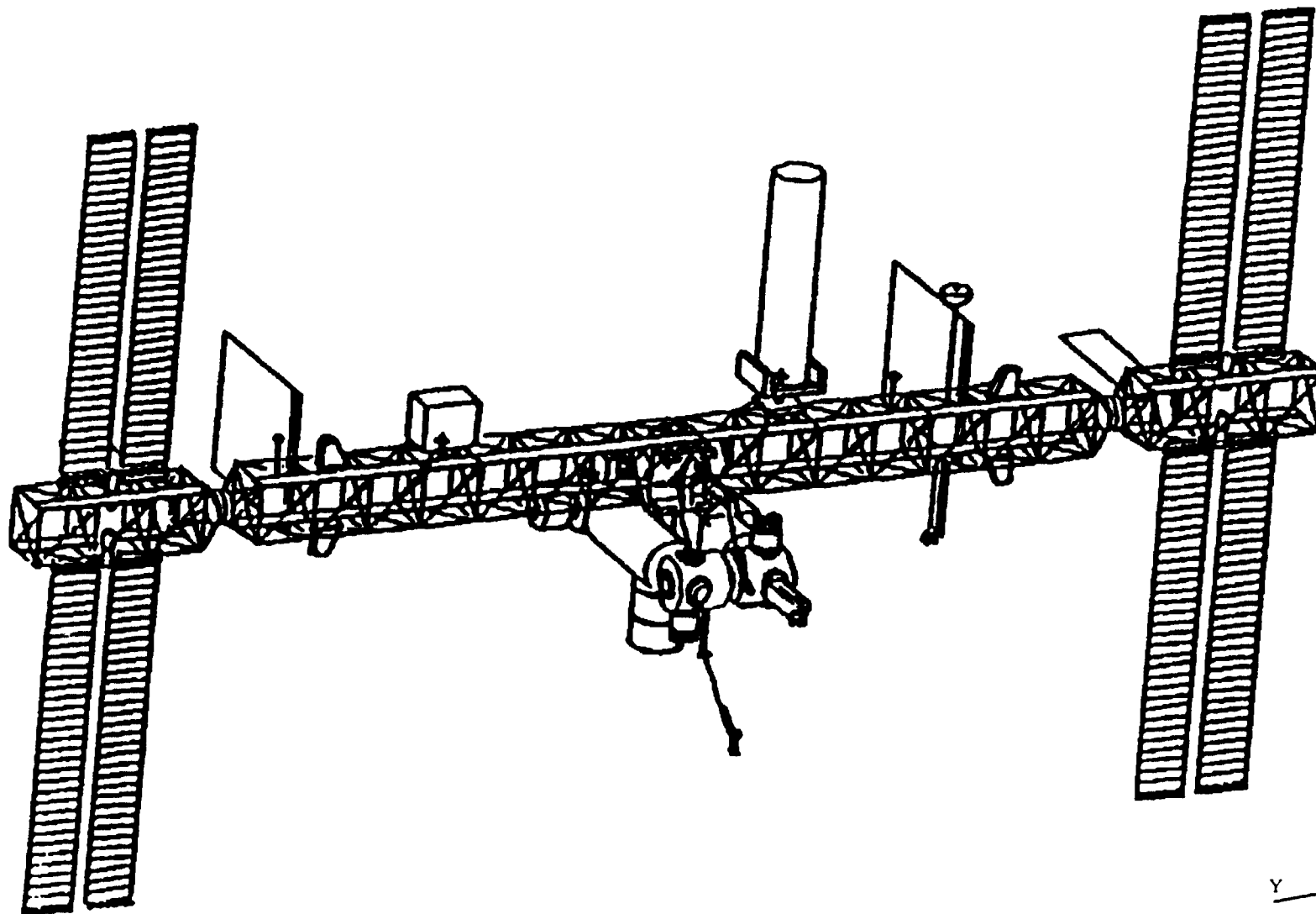
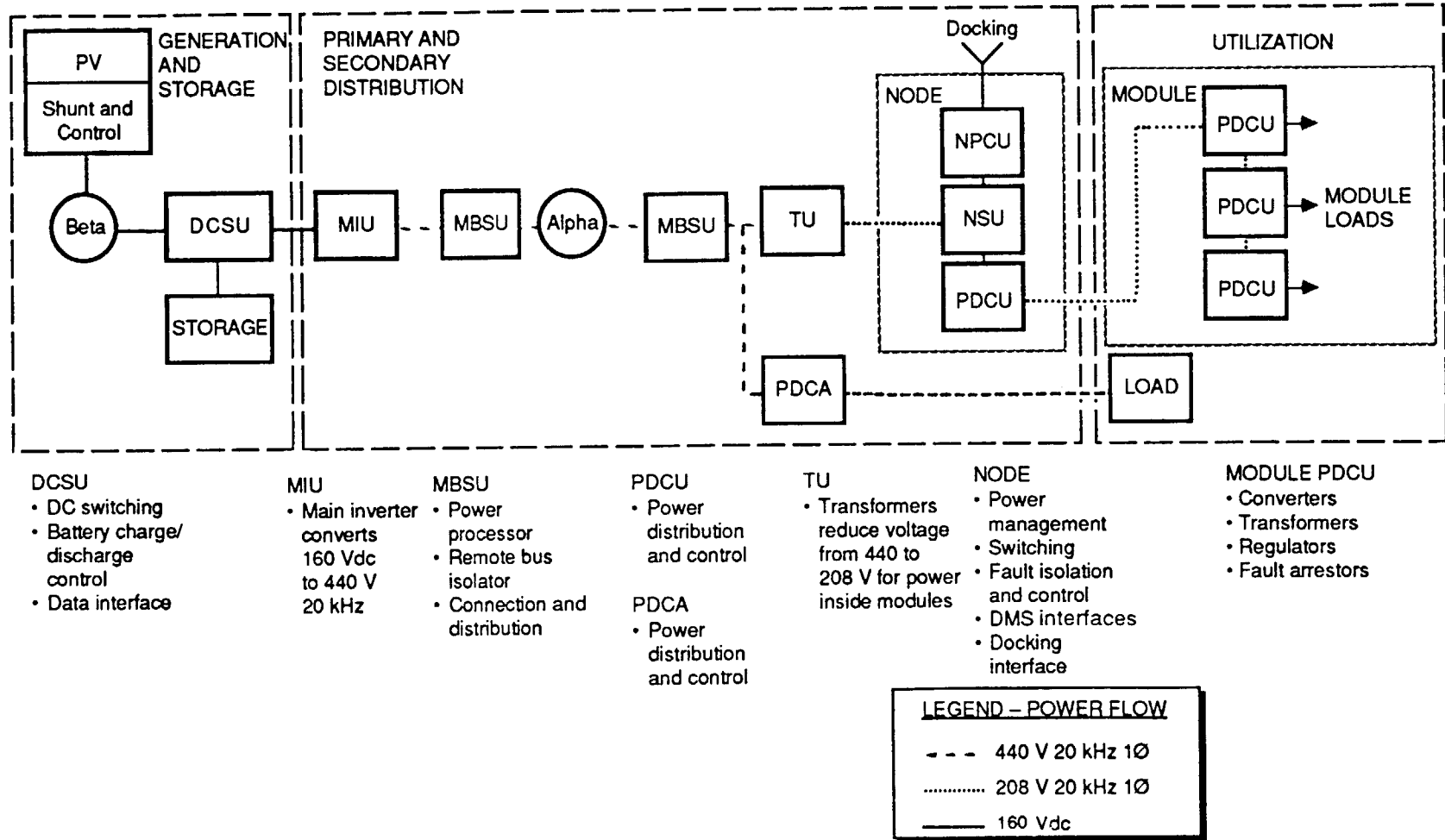

Figure 1-1. Space Station Configuration



DCSU

- DC switching
- Battery charge/discharge control
- Data interface

MIU

- Main inverter converts 160 Vdc to 440 V 20 kHz

MBSU

- Power processor
- Remote bus isolator
- Connection and distribution

PDCU

- Power distribution and control

PDCA

- Power distribution and control

TU

- Transformers reduce voltage from 440 to 208 V for power inside modules

NODE

- Power management
- Switching
- Fault isolation and control
- DMS interfaces
- Docking interface

MODULE PDCU

- Converters
- Transformers
- Regulators
- Fault arrestors

Figure 1-2. Space Station Electric Power System Functional Block Diagram

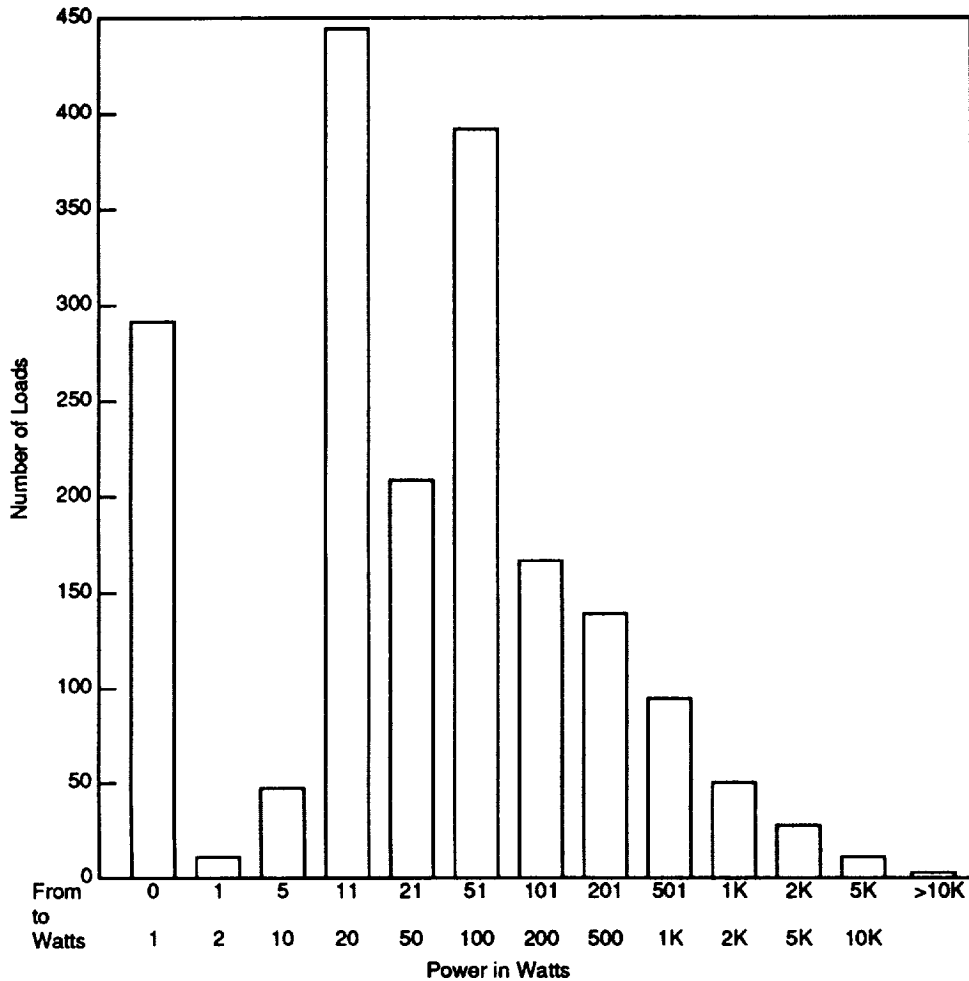

Figure 1-3. SS Manned Core Loads

loads projected for the Space Station will convert the 208 Vac to regulated dc. Dc usage is prevalent throughout the system (Table 1-1). Many electronic end loads use low voltage dc. Motors generally use low frequency alternating current (ac). Heaters and furnaces can be either ac or dc, depending upon the design. Thus, a review of the state-of-the-art components will aid designers throughout the system to better utilize available or near term components in their subsystem.

A third reason is that HVdc distribution may offer mass and efficiency advantages for Polar Orbiting Platforms (POP) and future coorbiting platforms used in conjunction with the Space Station. Platforms are more like conventional spacecraft, with power capacity in the range of 2 kW to 3.8 kW. Historically, dc power systems have been chosen over ac systems [1-1]. The information provided here may be useful for platform design.

A fourth reason is that the elements of the emergency power system on the Space Station may also utilize dc components. The information collected in this report may be useful for that design effort.

Table 1-1. Space Station Load Mix

Type	Voltage, Volts	Regulation, %	Frequency/ Phases	Percent of Total Load	Load Type
1	120	5	400/3	1	Lights, small motors
2	240	5	400/3	7	Pumps, motors
3	--	--	Variable	20	Induction heaters
4	--	--	Any frequency	21	Heating devices
5	5	2	dc	10	Electrical proc. and controls
6	15	2	dc	16	Electronic/inst. devices
7	50	5	dc	5	Controls, devices
8	28	10	dc	13	Critical devices, controls
9	150	2	dc	3	Battery processes
10	400	5	dc	4	Transmitters

1.3 DESIRED CHARACTERISTICS OF A SECONDARY DISTRIBUTION SYSTEM

Capacity, mass, efficiency, electrical noise (conducted and radiated), reliability, maintainability, audio noise, safety, and cost are the principal design considerations of the EPS. Table 2-1 shows the current experience with different power transmission-distribution systems used on spacecraft. It shows that there is a trend toward increased distribution voltage. Spacecraft such as the Shuttle (NSTS) have used 400 Hz power systems, similar to aircraft power technology, when larger power capacity was needed. Unfortunately, the noise environment generated by a 400 Hz system will not be acceptable to the Space Station experimenters [1-5]. Therefore, the 400 Hz distribution approach will not be considered in this report.

The military, motivated by reliability and weight considerations, has been developing 270 Vdc systems for aircraft [1-6], tanks, and submarines. Replacing hydraulic components with electromechanical actuators is attractive because it reduces weight while it improves reliability. For similar reasons, commercial aircraft manufacturers have also been interested in the 270 Vdc

effort. The systems and components developed for aircraft applications hold promise for space applications with proper derating to 120 to 160 V. However, only a few of these components have been qualified for the space environment.

A number of new developments such as smart power conditioners and power integrated circuits are leading to very compact high efficiency, dc/dc converters [1-7]. Internally, these dc/dc converters use an intermediate high frequency stage, with isolation transformer and rectifier. Because of the weight of the magnetic circuit elements, frequencies have trended upward in order to reduce converter mass. The current state-of-the-art converter frequency is in the 200 kHz to 2 MHz range. In computers and control applications, truly "distributed" power conditioners which can be incorporated onto individual, printed circuit boards will improve reliability and reduce costs of industrial-commercial equipment. The smart power business is increasing steadily and the trend is toward continued growth [1-8]. Dc-based smart motor controllers are another development which will have a profound impact on a wide range of products [1-7]. Although space environments are far more demanding, this commercial-industrial effort toward compact, efficient, and distributed power conditioners provides a large pool of technological building blocks and know-how to draw upon for designs for space power applications. These efforts should result in designs that are cost effective, reliable, and have low development risks.

1.4 SUMMARY

To summarize, the power capacity needs of the Space Station require the development of higher voltage distribution than the voltage levels of existing spacecraft. The proponents of dc for secondary distribution claim to have technical and cost advantages compared to the baseline ac system, and synergy with other industrial and military systems. In the following sections, we shall survey the specific developments and components available for 120 to 160 Vdc secondary power distribution and control.

SECTION 2

BACKGROUND

2.1 SECONDARY POWER DISTRIBUTION CONSIDERATIONS

The advances in solid state devices and methods of power management and control have resulted in the creation of improved methods of power distribution systems. Secondary power distribution systems can be either ac or dc. A 20 kHz primary and secondary power distribution system has been chosen for the Space Station [2-1]. An alternative to 20 kHz secondary distribution is the use of 120 Vdc distribution for modules and platforms, as described in Section 3.

A multiplicity of HVdc commercial components is currently available in prototype or in development form that can be used to implement an HVdc secondary distribution system for space applications.

It should be noted that at the distribution voltage levels for HVdc operation or 20 kHz operation, only few components have been space qualified.

2.2 dc EXPERIENCE ON AMERICAN SPACECRAFT

The majority of American spacecraft have had dc bus voltages. Most spacecraft, to date, have had power levels below 1 kW. The evolution of most spacecraft dc bus voltage generally centered at the NASA standard bus voltage of 28 Vdc. While some spacecraft utilized a regulated dc bus, others utilized an unregulated bus.

Even with the NASA standard, other spacecraft have had voltage levels up to 100 Vdc [2-2]. An American spacecraft bus voltage summary is shown in Table 2-1 [2-2]. It is evident that there is a tendency for bus voltages to increase as power levels increase. This generally results in lower cable mass and improved power conditioner efficiency. Information concerning power and voltage of various spacecraft is shown in Figure 2-1; it includes operational spacecraft and development types [2-3].

European spacecraft (selected types) have flown with a nominal 50 Vdc bus. Both European and Japanese spacecraft designers are presently directing their development and hardware efforts to a 120 to 160 Vdc spacecraft bus with a focus on secondary distribution for the Space Station [1-3]. The higher bus voltages have been designed to reduce cable mass, improve power conditioner efficiency, and reduce electromagnetic interference (EMI), because of reduced bus current.

Different loads on a spacecraft require different voltage levels. These vary from 3 Vdc for logic circuits to levels up to 10,000 Vdc for traveling wave tubes (TWTs). Data for Space Station loads are presented in Figure 1-3 and Table 1-1.

Table 2-1. Spacecraft Bus Voltage Summary [2-2]

TRW	Vdc
DSCS II (s)	23.7 to 33
DSP (s)	24.25 to 33
Classified Program (s)	24 to 32.5
FSC	20 to 70
Pioneer 10/11* (s)	28 ±0.6
HEAO (s)	23 to 33
OGO (s)	23.5 to 33.5
INTELSAT III (s)	21 to 31
TDRS	22 to 40

Hughes	Vdc
ANIK (s)	28 to 36
OSOI (s)	23 to 33
INTELSAT IV	23.8 to 48
WESTAR (s)	28 to 36
MARISAT (s)	28 to 38
TACSAT (s)	25 to 31.5
HASPS (s)	24 to 33
LEASAT (s)	28.7 to 31.9
ANIK-C (s)	28 to 42.5
SBS (s)	28 to 42.5

Ford Aerospace and Communications	Vdc
INSAT I (s)	26.5 to 42.5
SMS* (s)	29.4 ±0.2
IDCSP-A* (s)	29 ±0.6
NATO III* (s)	29.4 ±0.2
INTELSAT V (s)	26.5 to 42.5

RCA	Vdc
ITOS-D (s)	-26.5 to -36.8
DMSP* (s)	28
Satcom (s)	23.5 to 35.5
STC-DBS	100 ±1V 23.5-35.5

GE	Vdc
NIMBUS/ERTS (s)	-24.5 ±0.5
Japanese Broadcast Sat* (s)	29 ±1%
DSCS III* (s)	28 ±1%

Lockheed	Vdc
LST Study (R)	24 to 32
Classified Prog (R)	24 to 32
Type XI (R)	22.5 to 29.5
Agema (Z)	24 to 29.25

GSFC	Vdc
MMS (PRU)	21 to 35
OA0 (PRU)	21 to 33

MSFC	Vdc
Skylab (PRU)	28 Regulated
PEGASUS (Z)	28 Regulated

Table 2-1. Spacecraft Bus Voltage Summary (Cont'd)

JPL**	Vdc
MM 71 (Z)	50 Vac, 30 Vdc
MVM 73 (Z)	50 Vac, 30 Vdc
Viking Orbiter (Z)	2400 Hz 50 Vac, 30 Vdc
Galileo	2400 Hz 50 Vac, 30 Vdc
Voyager	2400 Hz 50 Vac, 30 Vdc

Fairchild	Vdc
ATSF and G* (s)	30.5 \pm 0.6Vdc
Shuttle/IUS Interface	
24-32 Vdc at 1.7 kW 400 Hz, 115/200 Vac, 3 ϕ , 390 VA	

Legend: s = shunt	* = regulated bus DET system
Z = zener diodes	PRU = array series regulator
R = relay switching of array power	** = Mariner TWT operate from unregulated dc bus

With the need of higher power capacity, higher distribution voltages are being considered for spacecraft such as Space Station, SP-100 [2-3], and projected electric propulsion systems. The selection of the upper limit voltage is determined by phenomena associated with space environments and components available in that voltage range. These phenomena [1-4] are:

- (1) Electrical discharge.
Electrical discharge can cause shorting between conductors and subsystems at voltage levels above 280 to 330 V, under space vacuum conditions.
- (2) Plasma discharge.
Plasma discharge can cause power loss in the array at 250 nm altitude. The effect is that the plasma acts as a resistor shunting the photovoltaic array. Power losses at 400 Vdc may be one percent or more of rated array power. Power loss begins to become noticeable above 160 Vdc.
- (3) Parts.
Certain critical parts that are voltage limited include tantalum capacitors, semi-conductors, and power devices. Problems occur in parts availability for operation above 160 V. However, design methods are available to overcome the voltage limitations of parts.

Considering these problems, selection of a voltage of 160 Vdc for the SS, the array, and the batteries, and 120 Vdc for secondary distribution inside the modules is considered to be conservative.

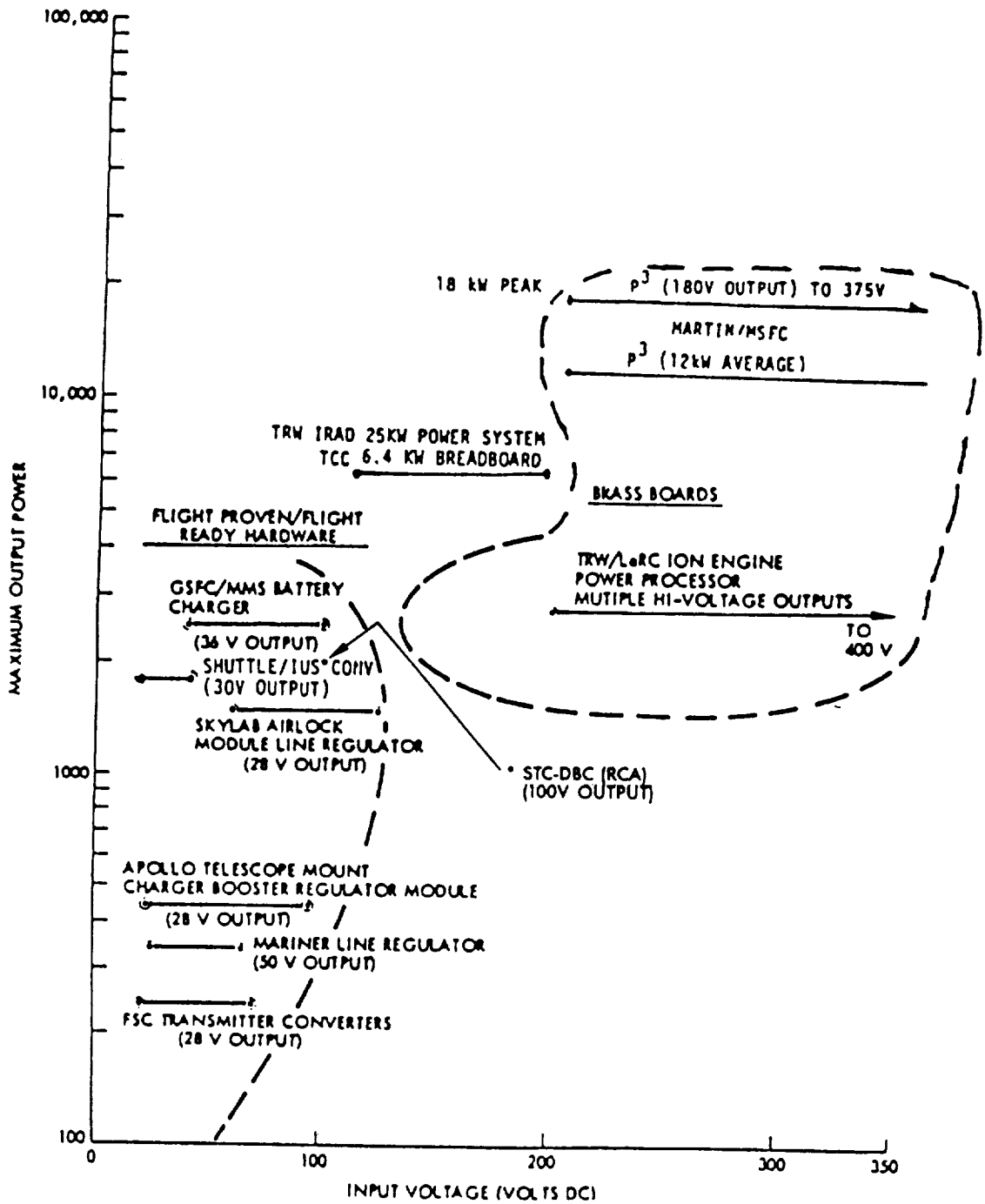

Figure 2-1. Power and Voltage of Various Spacecraft [2-3] (Flight Hardware and Developmental Spacecraft)

2.3

SYNERGISTIC DEVELOPMENT

Various activities are in progress in developing HVdc distribution systems [2-4, 2-5] for spacecraft, aircraft, submarines, and tanks. HVdc systems require smaller cables and lighter weight components because of lower currents. Also, in many instances, bulky hydraulic components can be replaced with lighter weight electrical components. Electrical systems provide higher efficiency than hydraulic systems. Moreover, reliability improves with electrical actuation [2-4] and control, and has been shown to be better with dc systems because of fewer components. These efforts have resulted in the technology and components which can be applied to HVdc distribution systems for space applications [2-4]. Development of system and components for HVdc systems has taken place over the past 15 years, mostly in the last six years. Thus far, 270 Vdc distribution systems are being developed for spacecraft, aircraft, and ground-based applications. Much of the material in this report summarizes the state of the art of these advanced distribution components developed for HVdc applications. A brief synopsis of these synergistic activities which have future application in spacecraft systems, follows.

2.3.1 100 Vdc Spacecraft Bus

RCA has developed a spacecraft (STC-DBS) using a dual bus voltage (100 Vdc and 35 Vdc). The topology of this spacecraft is shown in Figure 2-1 [2-2]. The 100 Vdc bus powers 6 TWTAs. Relays are used to switch the TWTs and heater loads. The 100 Vdc array generates 2 kW. RCA has qualified the Leach KCL-02A relay rated at 25 A and 35 Vdc to 100 Vdc operation. The TWT power supplies were also qualified at the 100 Vdc level. The spacecraft has been completely tested and qualified for space flight, and is ready to be launched. The important consideration is that space-qualified relays and other components have been developed and qualified for the STC-DBS spacecraft.

2.3.2 270 Vdc Bus Electrical Systems for Aircraft

Aircraft electrical power distribution has changed very little over the past number of years, even though substantial advancements have occurred in computers and communications equipment. The components used in the aircraft power distribution system and the methods of switching and protection, especially the protection of cable and wire, have had very few characteristic changes over the past two decades.

The physical size of modern aircraft requires long cable runs between the control (manual switches) and remote loads. A hydraulic-type constant speed drive, driving a 400 Hz generator, has been used to provide fixed frequency, three-phase aircraft power. Most military and commercial aircraft have used this method of secondary power generation (Figure 2-3a). The use of remote control circuit breakers has resulted in the reduction of cable mass and voltage drop. Circuit breakers are selected to have trip characteristics that allow handling of worst case overloads, transient inrush current, transient overloads, and cable protection without nuisance tripping.

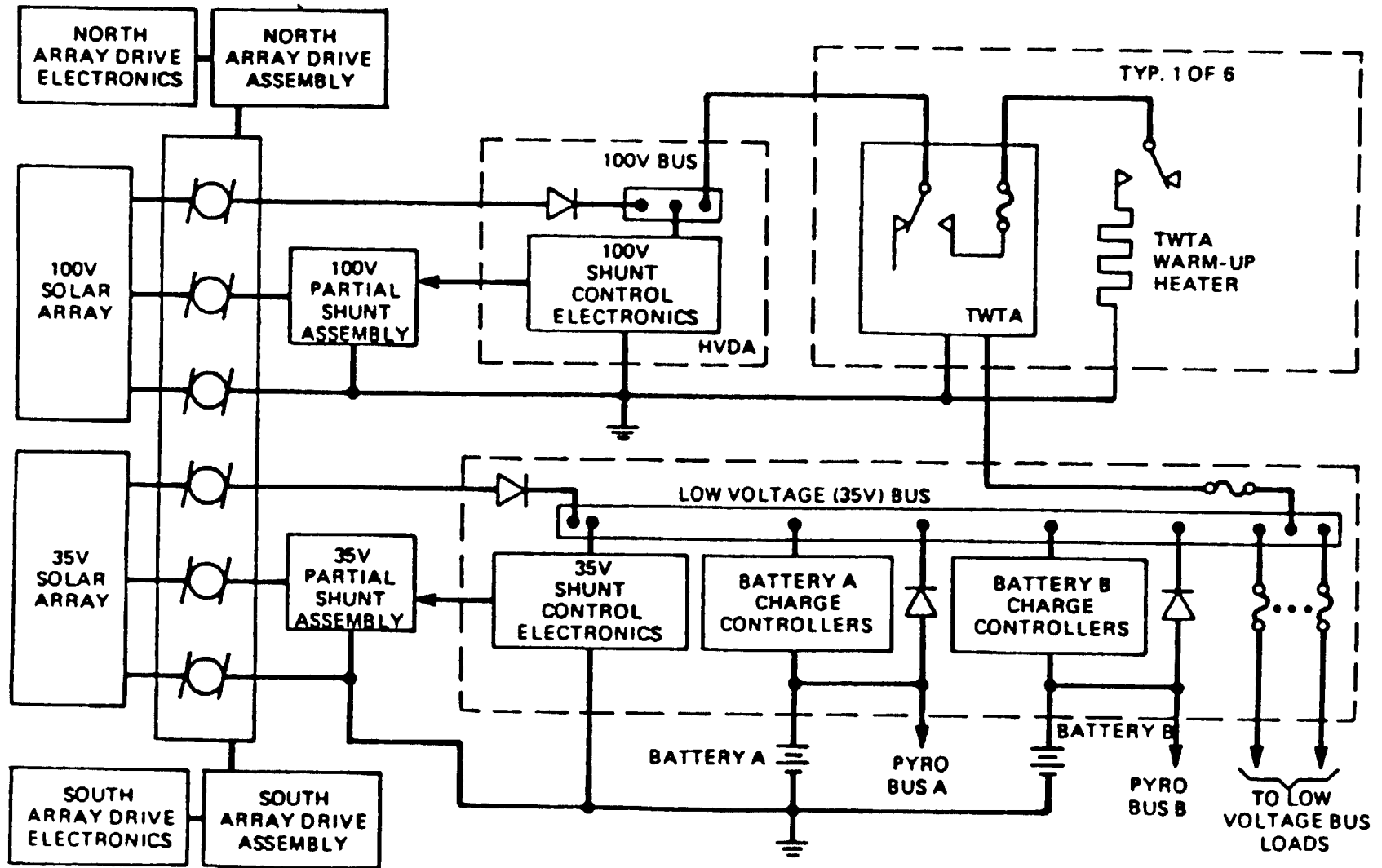

Figure 2-2. Simplified EPS Block Diagram RCA - (STC DBS)

Elimination of the hydraulic constant speed drive (Figure 2-3a) results in a system in which a variable frequency, regulated voltage is generated. This three-phase voltage, when rectified, produces a 270 HVdc bus. The configuration for the aircraft high voltage dc secondary distribution system is shown in Figure 2-3b.

The desire for reduction in aircraft weight, replacement of mechanical switches with solid-state devices, elimination of the hydraulic constant speed drive, as well as future computer control concepts, has been the goal of this ongoing development activity [2-5 through 2-10].

The scope of activities in the HVdc area encompasses the planning phase of new aircraft, breadboarding of HVdc power distribution systems, test and development of systems and subcomponents. The Society of Automotive Engineers, SAE standard No. AS1931 [2-7] defines the requirements for HVdc systems for aircraft. In addition, extensive design, development, and hardware efforts have been made in the areas of power system stability analysis, flat cable, safety issues, EMI, fault protection, power management, and control [2-11, 2-12]. At present, no firm decisions have been made to build an aircraft using HVdc bus. While technical problems still must be resolved, the main impediments to development are costs. The HVdc aircraft activities involve many organizations and manufacturers in the development and manufacturing of components and systems (APPENDIX A).

CONSTANT SPEED DRIVE

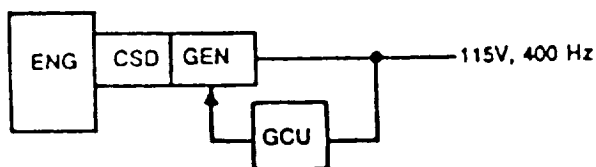

Figure 2-3a. Existing Aircraft Electric Power System

HIGH VOLTAGE DC

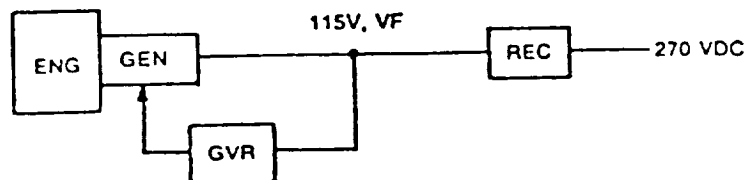

Figure 2-3b. Proposed Advanced Aircraft Electric Power System

2.3.3 High Voltage dc Bus Electrical Systems for Submarines

Submarines have used high voltage dc for high power distribution systems and have developed the technology to implement these designs. Switchgear, contactors, and other parts of the system utilize standard Navy-type devices. Most of the equipment utilized would not be applicable to space, due to the large mass and size of components. Another class of power distribution is being developed in the 100 kW power range. A unit of this type is being built for the Navy at the Newport News Shipbuilding Company [2-13, 2-14]. This distribution system operates at 155 Vdc and has been designed to operate lower power submarine electric loads. The system is designed with an ungrounded bus where cables, circuit breakers, and contactors are standard Navy-type components. Ground fault sensors are used in order to detect ground fault. Dc/dc converters are used to interface with loads.

A Navy standard, "Military Standard Interface for Shipboard Systems MIL-STD-1399," has been issued to define the 155 Vdc operating bus for shipboard systems [2-15].

2.3.4 270 Vdc Bus Electrical Systems for Tanks

There is an ongoing activity in developing tanks with an HVdc bus. The HVdc power distribution system for the Electric Gun and Turret Drive (EG/TD) has been breadboarded and tested at General Dynamics Land Systems Division [2-16]. The system is currently in the brassboard phase. Power rating will be in the range of 45 to 60 kW. The distribution system is similar to that used in the design of HVdc aircraft buses. The rationale for utilizing HVdc for this tank was to reduce mass of the distribution system components and cable.

In this distribution system, three-phase, ac generator output is rectified to obtain an HVdc distribution bus. Solid state remote bus isolators (RBIs) are used in the generator output lines in order to replace electromechanical components. Solid state RBIs and remote power controllers (RPCs) will be used for switching and protection functions. Dc/dc converters will be used for regulating load voltage.

SECTION 3

SPACECRAFT HIGH VOLTAGE dc SYSTEM TOPOLOGY

3.1 SPACE STATION SECONDARY DISTRIBUTION

The planned primary distribution of power on the space station will be at 440 V, single phase, and 20 kHz [1-3, 2-1]. The planned baseline secondary distribution is 208 Vac, single phase. The Space Station power system, including the primary and secondary power distribution systems, is shown in Figure 3-1. The array voltage in Figure 3-1 is distributed to a 20 kHz inverter and to a battery subsystem and controller at 160 Vdc (the same level as discussed in Section 2). The battery subsystem charge controller is used to charge the batteries. The array shunt regulator and the battery discharge controller are used to regulate the dc bus voltage at 160 Vdc. All the equipment developed for the array/battery subsystem including charge/discharge controller, RBIs, and dc/dc power conditioners, can be used in the HVdc secondary power distribution option (208 V, 20 kHz, single phase) in a modified form, or as is.

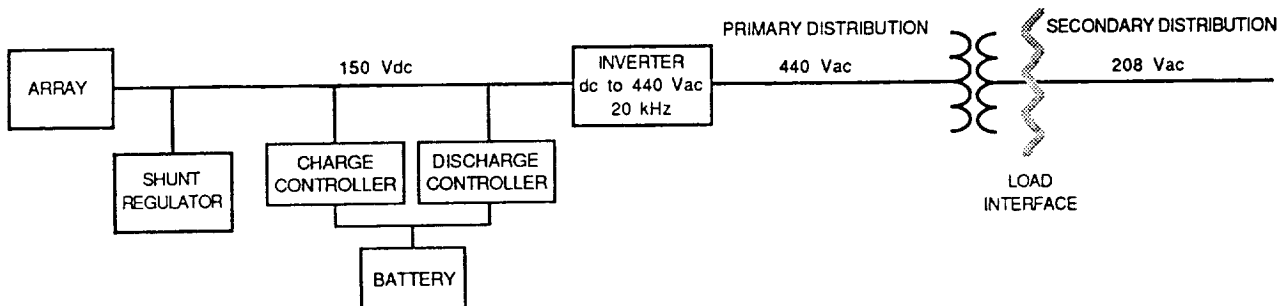

Figure 3-1. Space Station Baseline Power System Block Diagram

A detailed configuration of the space station HVdc secondary distribution option is shown in Figure 3-2. The selection of a spacecraft secondary distribution dc bus voltage is determined by a number of factors [3-1]. Many of the components and systems to implement this secondary distribution bus are detailed later in this report. On the array side of the spacecraft, as previously discussed, voltage selection is made at a level that will tolerate the effects of plasma discharge and electrical discharge and allow the use of available electronic parts. A level below 200 Vdc is considered safe, in terms of plasma discharge. Space Station nominal array voltage and power generation is 160 Vdc and does not exceed 200 Vdc under extremes of environmental conditions or load operation. On the secondary distribution side, 120 Vdc is considered a conservative voltage selection. At that voltage, electrical discharge (corona) from outgassing effects does not become a problem. Also, the required components are readily available at the 120 Vdc level. In addition, 120 Vdc is considered safe from a human factors safety point of view [3-2].

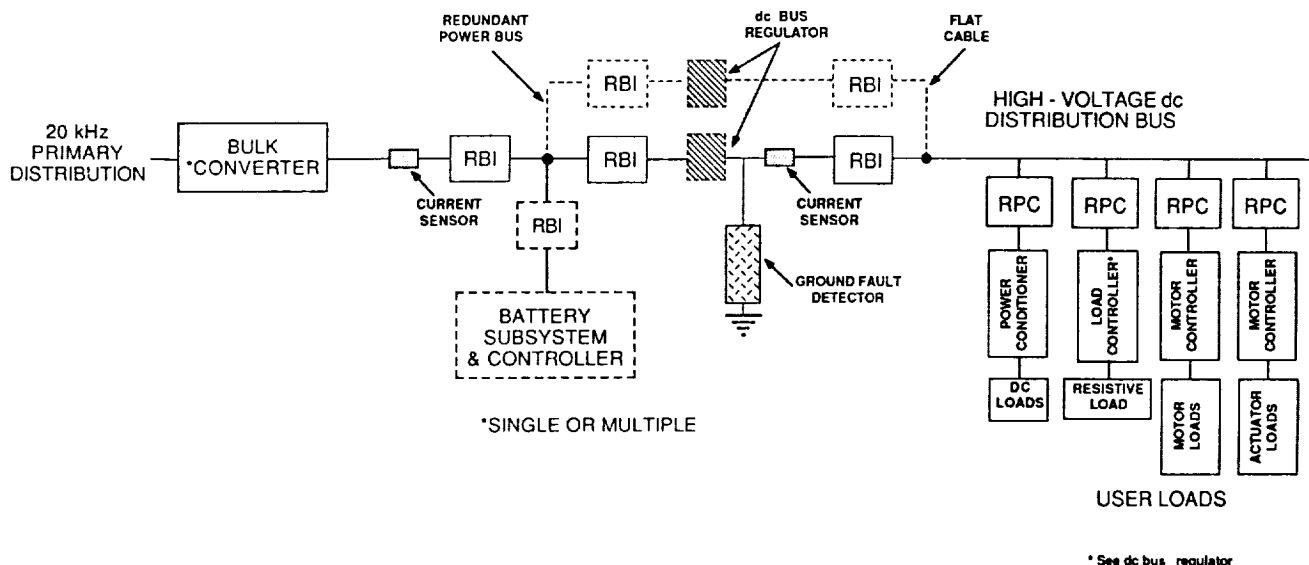

Figure 3-2. Space Station Secondary Power Distribution, HVdc Option

Proper grounding practice must be exercised in HVdc for modules and platforms. HVdc platform grounding practice should follow those procedures developed for LVdc spacecraft. Grounding practice for HVdc modules is simplified by using a dedicated isolation transformer between the primary distribution bus and the module. This allows for single point grounding of all the modules and will satisfy the requirements of the Space Station Grounding Standard [3-3].

3.2 PLATFORM POWER DISTRIBUTION

208 Vac 20 kHz power distribution is baselined for free flying platforms [Figure 3-3]. It uses an architecture similar to that of the Space Station.

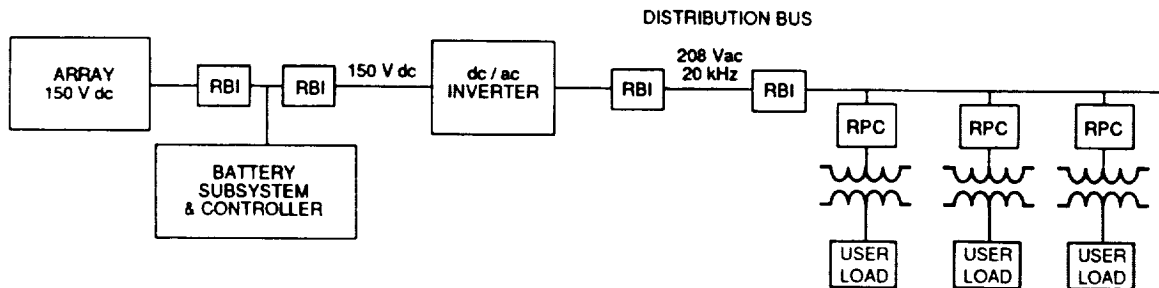

Figure 3-3. Free Flyer Platform Power Distribution (Space Station Baseline 20 kHz ac)

An HVdc alternative to the baseline is shown in Figure 3-4. It shows power generation and distribution at 120 Vdc. If a 160 Vdc array voltage is used as for the primary power system, then a dc/dc converter will be required to reduce the 160 Vdc array voltage to the desired 120 Vdc level.

Remote bus interrupters are used to disconnect sections of the distribution system and subcomponents for maintenance. In addition, a dc bus regulator is shown as a means of matching the bulk array voltage to the power distribution voltage in order to provide tight bus voltage regulation.

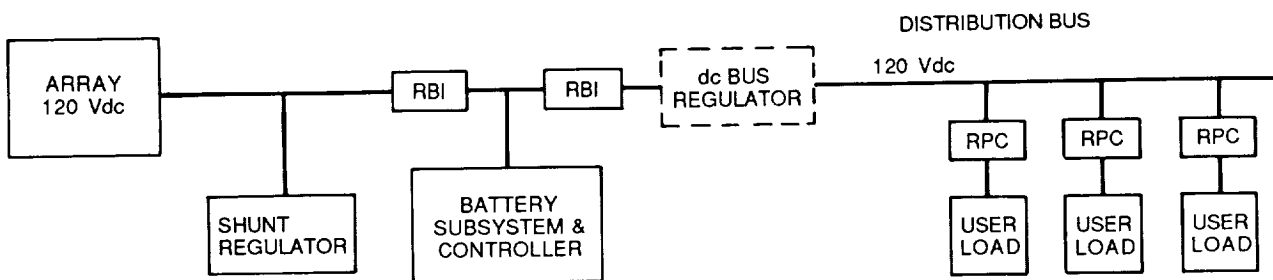

Figure 3-4. Free Flyer Platform Power Distribution (HVdc Alternative to Space Station Baseline)

The battery charge/discharge controller subsystem has been detailed in previous studies for Space Station, and since the components developed are applicable to the module and the platform power distribution system, they will not be discussed. The remaining components, other than user loads, are shown in Table 3-1. Techniques of power management and control are described in Section 10.

Table 3-1. Secondary Power Distribution Components

Component	Comments
Flat cable Power conditioners Load controllers ac Motor drives Ground fault detector Current sensors Remote bus isolators (RBI) Remote power controllers (RPC)	See Section 6 dc/dc converters (electrical isolation) Resistive load control (dc/dc converter, none isolated) Inverters (including brushless dc motor control) Senses bus to ground faults Electrically isolated dc current sensors Solid state switch for power bus control Solid state switch for load control and switching

The types of loads used will determine the types of electrical components used and their power ratings. Secondary distribution systems will be in the modules and in the platforms. Table 1-1 provides the percent distribution of the types of loads in the Space Station, including modules and platforms. Components are sized to the required load applications. Component details are discussed in Section 5.

SECTION 4

SPACECRAFT COMPONENT CONSIDERATIONS FOR HIGH VOLTAGE DC SYSTEMS

4.1 APPLICATION CONSIDERATIONS

The topology of a typical HVdc secondary power system was shown in Figure 3-2, and the components used to implement this topology were shown in Table 3-1. Each of the component groups tabulated performs particular functions and generally has a range of operational characteristics associated with them. Some of the important design objectives to implement a high voltage dc secondary distribution system are shown in Table 4-1. Examples of existing HVdc technologies to carry out these objectives are discussed in Section 5, along with component functions and characteristics. The component survey, below, will focus on those components that would have future application for a secondary power distribution voltage in the range of 120 Vdc to 160 Vdc, and power ratings up to 25 kW.

Different types of loads require different power controllers. Three types of power controllers are discussed in this report. First, there are power conditioners which are dc/dc converters with electrical isolation and provide the required regulated output voltage. Second, there are dc bus regulators which are used to interface a high voltage bus to a lower voltage bus (160 Vdc to 120 Vdc), typically without electrical isolation. They are also used to control heater and resistor loads. Third, there are motor controllers which are used to control the speed of three-phase and single-phase ac motors, typically 400 Hz types. The Space Station load mix is shown in Table 1-1.

Table 4-1. High Voltage dc Distribution System Design Objectives

- o High Reliability (low parts count)
- o High Efficiency
 - o System
 - o Power conditioners and other components
- o Low EMI (Based upon previous low voltage spacecraft experience, MIL-STD-461B plausible)
- o Solid State power switching
- o Safety
- o Flat cable for minimum mass, dc voltage selection for low cable mass
- o Module Operation; emergency power/uninterruptible power supply to back up critical loads
- o Effects of plasma discharge and electrical discharge should not alter system efficiency and reliable operation

4.2 REMOTE BUS ISOLATOR (RBI)

The term RBI defines an interrupter that can be remotely controlled to connect and interrupt secondary distribution power. Historically, interruption of distribution power was accomplished with circuit breakers. They were designed to interrupt ac and dc loads. Circuit breakers are being replaced by new classes of electronically controlled power switching devices. The requirement of this class of solid state, hybrid or electromechanical interrupters is that they can be controlled by a central power management and distribution computer (PMAD), typically interconnected to a MIL-STD-1553B data bus [4-1]. Current levels for the secondary power distribution systems may vary from 25 A to 200 A, and voltage levels from 120 Vdc to 160 Vdc, according to the module or platform rating. The interrupter will allow the connection or disconnection of different sections and components of the distribution system. Topologies using RBIs are shown in Figures 3-2 and 3-4. The RBI will permit the maintenance of parts of the distribution system that are redundant and will allow the rerouting of distribution power to loads, as required.

Interruption of fault current and overload current is desired in order to protect the interrupting devices, cables, generation sources, storage components, and critical load components.

The Space Station array/battery subsystem HVdc distribution system uses solid state power interrupters. High reliability is essential and low power losses are needed, in order to maintain high systems efficiency. Mass and volume should be low and consistent with spacecraft performance requirements.

There are three classes of remote bus isolators (RBI) that can connect and interrupt dc bus power. These are:

- (1) Contactors.
- (2) Hybrid Power Interrupters (Solid State and Electromechanical combinations).
- (3) Solid State Power Interrupters.

Each of the above classes of isolators/interrupters has its own particular characteristics, which are described in Section 5.1.

4.3 REMOTE POWER CONTROLLERS (RPCs)

The term RPC defines an interrupter that can be remotely controlled to connect and interrupt a load. Solid state RPCs are similar to solid state RBIs except for differences in function and current rating. Historically, interruption of both dc and ac loads was accomplished by relays.

Relays (some of which are space qualified for HVdc [2-2]) are being replaced by new classes of electronically controlled solid state power switching devices [4-2 and 4-3]. The requirement of this type of interrupter is that they can be controlled by a central power management and distribution (PMAD) computer, typically interconnected to a MIL-STD-1553B data bus. Current levels

for loads in the Space Station secondary distribution system may vary from 1 A to 25 A, and voltage levels from 120 Vdc to 160 Vdc, according to a module or platform voltage rating. RPCs are used to connect and disconnect user power conditioners, ac motor drives, and other components to the secondary distribution bus. An application of the RPC is shown in Figures 3-2, 3-3 and 3-4.

Interruption of fault current and overload current is desired in order to protect the interrupting devices from excessive currents, associated cable, inrush surges on the distribution bus, and critical load components.

Detailed characteristics for RPCs are shown in Section 5.2.

4.4 POWER CONDITIONERS

Power conditioners are used to interface the secondary distribution bus and provide a load with the desired voltage and regulation characteristic. They also regulate voltage to the load and provide electrical isolation. Low mass and high efficiency are design objectives. Various topologies are used in power conditioner design [4-4]. All of the techniques used utilize an internal switching frequency. The higher the switching frequency the lower is the mass of the magnetics. The optimum band for switching frequency, which is dependent on magnetic hysteresis losses, is between 200 kHz and 1 MHz [Appendix C]. Power conditioners mass and volume can be reduced compared to 20 kHz designs by operating the power conditioner at higher switching frequencies (above 100 kHz) while still maintaining high efficiency. Power conditioner design also requires low EMI levels consistent with spacecraft EMI requirements (typically MIL-STD-461B). Generally, dc power conditioner designs are similar to those used on 28 Vdc buses, with the exception that the components must operate at higher voltage levels. Load voltage requirements are generally in the +5 Vdc and + 15 Vdc range. Power ranges from 25 W to 50 kW are described in Appendix C and Section 5.3.

4.5 ac MOTOR DRIVES

Many loads such as actuators on larger spacecraft require ac motor drives to provide appropriate voltage and frequency to a motor load [4-5]. The efficient conversion of spacecraft primary distribution or secondary distribution power to single- and three-phase power is required. Motor control may be at a fixed voltage and frequency or it may be at a variable voltage and variable frequency. Variable frequency/variable voltage control provides a means of accelerating a motor load without large inrush currents. Constant torque operation requires a constant volts/hertz motor drive. Waveform synthesis, bilateral operation, and regulation of voltage and frequency are important parameters in the design of an ac motor drive. Waveform synthesized, pulse width modulated (PWM) inverter type motor controllers are used extensively in commercial, military, and spacecraft applications. These inverters are noted for their bilateral characteristics (energy may be fed to the motor or returned to the source). This class of inverters is noted for its high efficiency and the minimum usage of power semiconductors.

Electrical isolation from the spacecraft bus is not required for driving motor loads because of EMI or safety concerns. Since this class of inverters is bilateral in nature, complex power and logic control circuitry and components are unnecessary to implement these design topologies. State-of-the-art ac motor drives are described in Section 5.5.

4.6 dc BUS REGULATOR

The dc bus regulator provides the function of interfacing an array or voltage source at one voltage level to a voltage level required by the secondary power distribution bus. An example of this is conversion of 160 Vdc to 120 Vdc or from a low voltage to a higher voltage as in a battery discharge controller. The dc bus regulator is not typically used in 28 Vdc spacecraft. Regulated dc voltage is supplied by the array/battery subsystem as shown in Figure 3-2. The added use of a bus regulator will provide improved distribution voltage regulation, generally low source impedance with improved EMI and transient characteristics. The same type of dc bus regulator can also be used to control resistive and heater loads. It should be noted that these converters do not have electrical isolation since it is not required for the function performed, and as a result of eliminating a transformer, efficiency and mass of the regulator is improved. State-of-the-art dc bus regulators are described in Section 5.4.

4.7 CURRENT SENSORS/GROUND FAULT SENSORS

Electrically isolated current sensors are used to monitor and sense the dc current. Such a measurement is critical to protect and control current within the distribution and conversion system. Electrical isolation provides a means of isolating the secondary power bus from interfacing data and control buses.

Ground fault sensors provide a means of identifying faults from the power bus to the spacecraft structure, and typically interface through a MIL-STD-1553B data bus to the spacecraft power management and distribution system control. State-of-the-art sensors are described in Section 5.6.

SECTION 5

COMPONENTS TO IMPLEMENT AN HVdc DISTRIBUTION SYSTEM

This section presents examples of HVdc components that have been developed for Space Station, aircraft, and other applications. All the described components have the potential to be used in space vehicle electrical power distribution systems. The list of devices and manufacturers was developed to reflect the broad scope of activities previously and currently in progress. The list is representative of available components and does not encompass all ratings and manufacturers of these types of components.

Many of the components described have been designed and tested for extremes of environmental and electrical conditions. The components described reflect a high level of development including technical and performance capabilities, and many can be applied to space applications. All will need space qualification testing and may need redesign for the space station application. Most components appear to be viable candidates for an HVdc secondary distribution system [5-1]. The steps required to adapt these components for space usage are as follows:

- (1) Modification for operation at the required voltage and current levels.
- (2) Modification of the design for thermal conditions and heat rejection in the space environment.
- (3) Selection of appropriate space-qualified parts to perform the required function.
- (4) Modification, as required, for operation per MIL-STD-461B.
- (5) Qualification to the appropriate reliability level required.

5.1 REMOTE BUS ISOLATORS (RBI)

5.1.1 Contactors

Contactors are electromechanical relay devices that close or open contacts to supply load power or interrupt load. Contactors are useful to provide a positive disconnect of a particular section of a bus if maintenance is required. The contactors needed for space applications differ from the conventional submarine and locomotive contactors in that the means of suppressing the arc generated in opening the contact is accomplished with magnetic blowouts. Using magnetic materials such as samarium cobalt results in a low mass and volume contactor. For space applications, special means are necessary to provide for arc extinguishing [5-2], such as hermetic sealing of the contactor with container pressurization. Contactors are not designed to protect spacecraft cable or connected loads in the event of a fault. If the purpose of the contactor is to provide disconnect for bus maintenance and not for opening or closing of current, then special hermetic sealing and pressurization may not

be required. Examples of existing contactors for this application are shown in Table 5-1, with current range from 80 to 650 A and voltage levels up to 340 Vdc.

Table 5-1. High Voltage dc Contactors

Manufacturer	Voltage Rating (Vdc)	Current Rating (A)	Size, in.	Weight (lb)
Hartman Electric Co. [5-2]	326	80	5.5 x 4.5 x 4.3	2 (Hermetic Seal)
	270	100/600 surge	3 x 2 x 2.5	12 oz
	270	200/600 surge	4 x 2 x 3.25	20 oz
	270	400 nonbreak	5.5 x 4 x 4	2.75
	340	650	7.1 x 5.3 x 4	7
Eaton Corp., Cutler Hammer Division [5-3]	270	250	6 x 6 x 4	6

5.1.2 Hybrid Power Interrupters

Hybrid power interrupters incorporate electromechanical contactors with solid state devices across the contactor contacts, and are used in applications where distribution load currents are switched. A functional block diagram of a high voltage dc hybrid power interrupter is shown in Figure 5-1, and a block diagram of control and system elements is shown in Figure 5-2 [5-4]. In this interrupter, the main contacts of an electromagnetic contactor are shunted by a power semiconductor switch. Prior to disconnecting a load, both the mechanical contacts and the semiconductor switch are on. When a signal is provided to turn off the hybrid switch, the mechanical contact is opened and the load is carried by the solid state switch. After the mechanical contact is open, the solid state switch is turned off. For hybrid power interrupter turn-on, the solid state part of the power switch is turned on to carry the load, after which the mechanical contactor is energized (closed). The load is then transferred from the solid state switch to the mechanical contact. Load current is carried by the mechanical contacts in order to reduce power loss. These interrupters have provisions for both input and output overvoltage

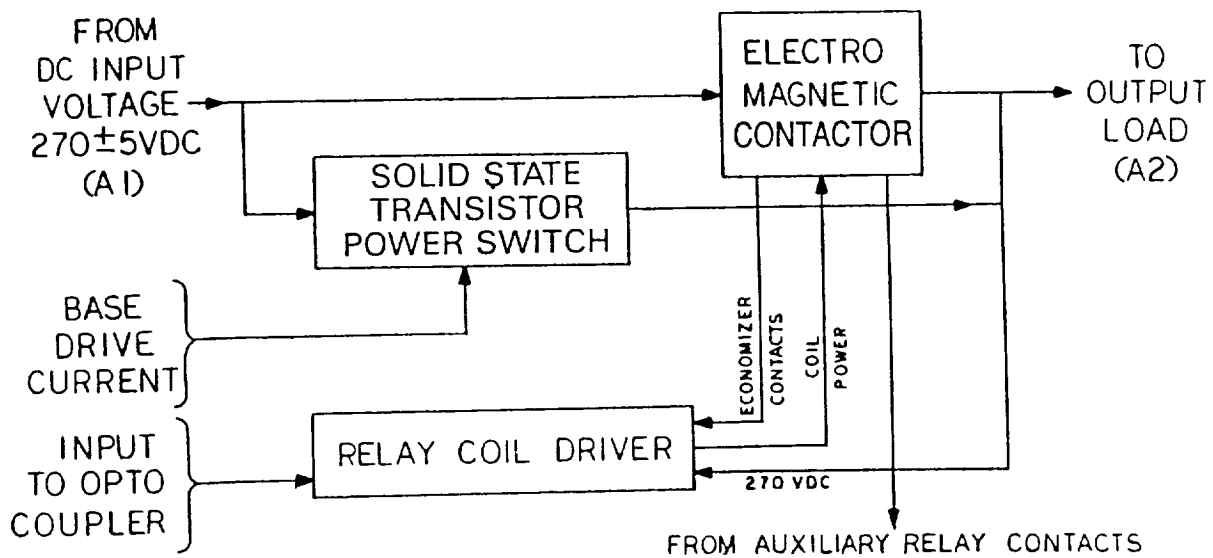

Figure 5-1. Functional Block Diagram of Hybrid Power Interrupter [5-4]

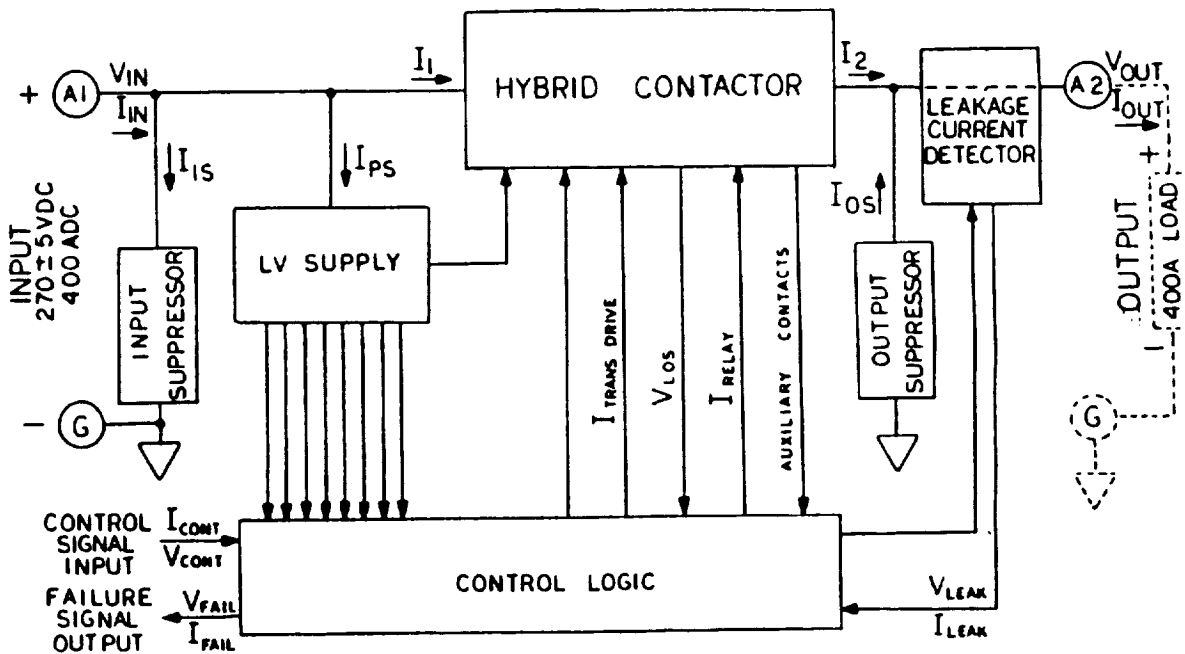

Figure 5-2. Hybrid Power Interrupter Block Diagram [5-4]

suppression. They are actuated by a control input signal and provide a failure signal output. The interrupter can be interfaced to microprocessor control. Internal logic power, control logic, leakage current detector, and diagnostics are also shown.

Other methods of implementation of this design differ according to the desired function. Eaton Corp., Cutler Hammer Division allows for interruption of multiple thousands of amperes of fault current duplicating in some fashion the characteristics of a circuit breaker [5-5]. Lockheed allows interruption of a certain level of overload current which is characteristic of the contactor rating [5-4]. It should be noted that both of these interrupters are readily adaptable to microprocessor control. Examples of the current rating and surge rating for four separate manufacturers are shown in Table 5-2. The sizes shown range from 80 to 400 A dc at a voltage rating of 270 Vdc.

Table 5-2. 270 Vdc Hybrid Power Interrupters (RBI)

Manufacturer	Current Rating (A)	Surge Rating (A)	Size, in.	Weight, lb
Lockheed Advanced Marine Systems [5-4]	400	600	8 x 8 x 8	14
Westinghouse [5-6]	80	100	5.5 x 3.5 x 6	3.5
Teledyne Kinetics Division [5-7]	100	1500	3 x 2.5 x 4	3
Eaton Corp., Cutler Hammer Division [5-5]	100	1500	4 x 4 x 2	3

5.1.3 Solid State Power Interrupters (RBI)

Solid state power interrupters offer performance capabilities, some of which are not found in circuit breakers, contactors, or hybrid interrupters [5-8]. Two manufacturers of solid state power interrupters are shown in Table 5-3. The two units described have been designed for different applications. The Westinghouse unit was designed to be used on the Space Station, and the Lockheed unit was designed for undersea applications. Figure 5-3 shows a typical solid-state power interrupter block diagram. The main components of this interrupter consist of a semiconductor power switch, driver, current sense, voltage sense, over current trip, monitor circuits, and a data (MIL-STD-1553B) interface unit. The rating of this interrupter developed by Westinghouse Electric Corporation is 150 A at 150 Vdc (22.5 kW). A general

Table 5-3. Solid-State Power Interrupters (RBI)

Manufacturer	Current Rating dc	Voltage Rating dc	Switch Opening	Size, in.	Weight, lb.	Comments
Westinghouse [5-9]	150 SPST	150	10 ms MAX (Figure 5-4)	11.5 x 15 x 5	15	(See 5.1.3, Design Characteristics listing) o Current limit level adjustment o Analogue monitoring circuits V, I, current set o Digital monitoring circuits o switch status o trip status o current sensing polarity o I/O interface circuits
Lockheed Advanced Marine Systems [5-10]	117	150	300 A surge <1 s	Part of DSRVs vehicle		o Current limiting at 4 x load current o Opening of switch at 10 A/μs o Closing of switch >10 A/μs o Trip and loss of saturation trip

description of generic RBI characteristics is shown below. Many of the characteristics described are those for Westinghouse Electric Corporation Part No. ED406490-1 [5-9]. The critical characteristics are current limiting, short circuit protection, controlled current turn on and turn off, and low power dissipation. These characteristics will differ according to the manufacturer and RBI requirements.

The design characteristics for solid state RBIs are as follows:

- (1) Short Circuit Protection. High speed fault clearing capability is provided up to the current and thermal limit of the solid state switches used. Typically, under short circuit conditions, switch opening time will be one microsecond. At other levels of overload current, turn-off time will vary up to 2 milliseconds. This operating time is coordinated with the curve shown in Figure 5-4. The voltage drop across the RBI is a function of current through the device. This curve is used to define a safe operating mode for the device.

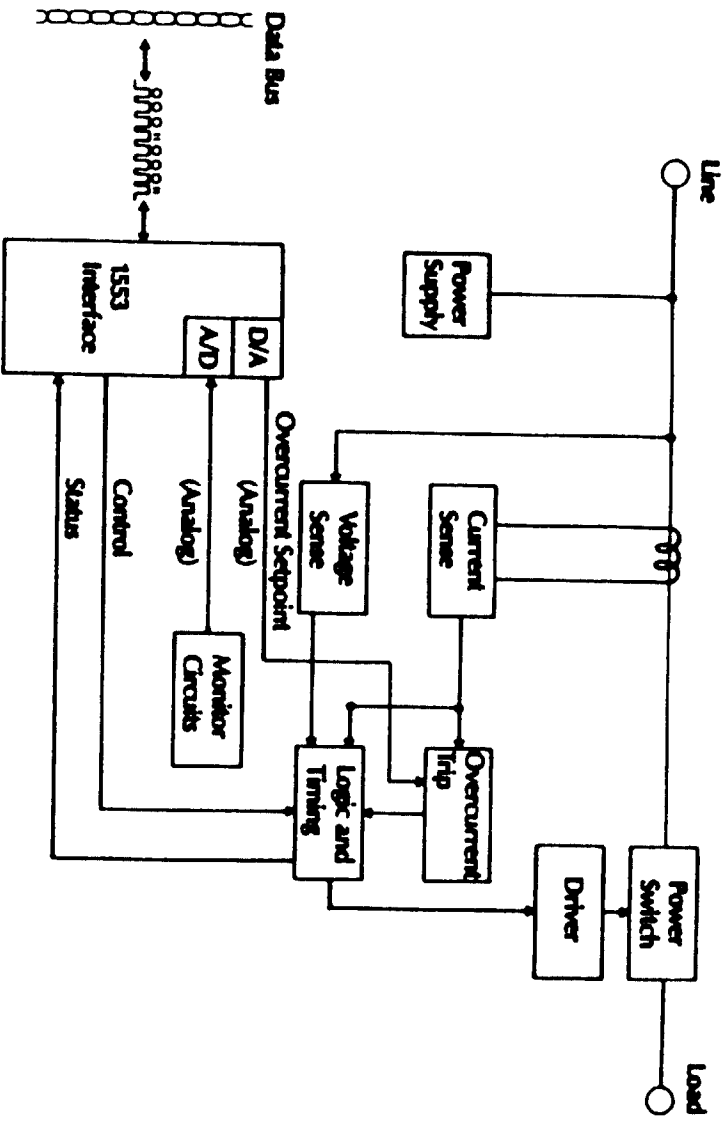

Figure 5-3. Typical Solid-State Power Interrupter Block Diagram [5-11]

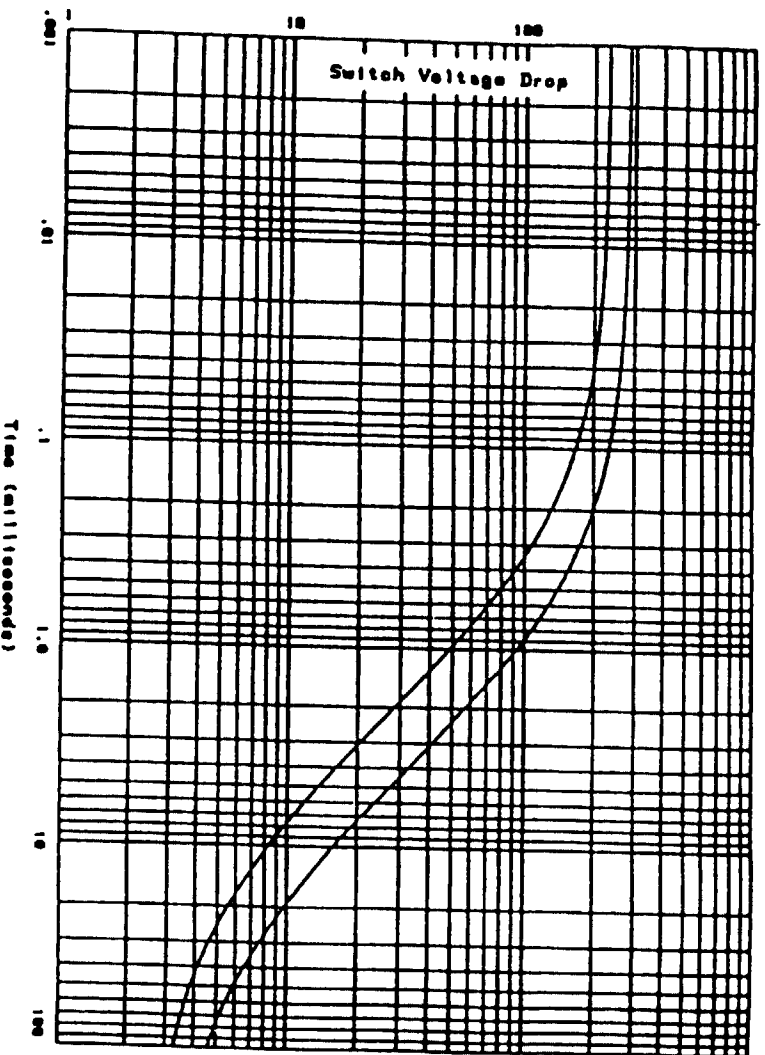

Figure 5-4. RBI Trip Characteristic [5-9]

- (2) Current Limit. Current limit if designed in the interrupter will limit current to a prescribed level. This level can be pre-set or adjusted by the PMAD computer. Turning the switch on into a capacitive or resonant load will limit current to adequately charge up a bus capacitor without interrupter trip.
- (3) Switching Life. Switching life is several orders of magnitude greater than contactors or circuit breakers.
- (4) Built-in Diagnostics. Internal provision can be made to identify component failures. Internal signals can provide information as to failure in the solid state interrupter or in other parts of the proven distribution system.
- (5) Status Feedback. Status feedback signals will provide monitoring of the various operational states of the interrupter.
- (6) Bidirectional Current Limiting. The solid state power interrupter can be designed for bidirectional operation with bidirectional current limiting (Table 5-2, Westinghouse). What this functionally implies is that current could flow in either direction and can be provided with short circuit interrupting capability and current limit in both directions. This feature is useful for system protection when protection is provided for multiple batteries and energy is exchanged between battery subsystems.
- (7) Bidirectional Operation. Bidirectional operation is useful when feeding regenerative loads (such as certain types of motor loads). This allows return of energy from the regenerative load to a battery or to other loads in the system.
- (8) di/dt Limiting. The rate of rise of fault or overload current will be monitored without using inductor limiters to allow for high surge capability. This is desired in both the turn on or turn off modes to prevent excessive voltage and current stress on the power switching element. Controlled di/dt reduces EMI in the system.

In addition to the above, which are generic in nature, the following important characteristics can also be incorporated:

- (1) Matching I^2t characteristic to protect system cable.
- (2) Current level monitoring.
- (3) Current leakage monitoring.

Many of the above characteristics are also incorporated by Lockheed Advanced Marine Systems Division in the RBI as shown in Table 5-3.

5.2 REMOTE POWER CONTROLLERS (RPCs)

Remote power controllers are devices that functionally replace conventional electromechanical relays in the 1 to 30 A size. In addition to the function of supplying power to a load and interrupting power to the load, the functions of the RPCs are similar in characteristic to the solid state power interrupters discussed earlier with a difference in current ratings. The Solid State Power Interrupter Block Diagram (Figure 5-3) is similar to that for Remote Power Controllers (RPCs). A summary of some of the most significant characteristics for the RPCs follows [4-3 and 5-12].

- (1) Controlled rate of rise and fall of current.
- (2) Short circuit protection.
- (3) Current limiting to prevent load transients.
- (4) Wide temperature range.
- (5) Electrical isolation of control and status signals from the power bus.
- (6) High-speed trip-out response characteristics.
- (7) Diagnostic capability.
- (8) Load capacitor charge capability.
- (9) Programmable trip characteristics.

It should be noted that these characteristics are typical for a 120 Vdc 5 A device (Table 5-4 Westinghouse), but many of these characteristics apply to other manufacturers and other current levels [5-13]. A trip characteristic is shown in Figure 5-5. This trip characteristic is used to coordinate cable, load, and RPC device protection.

There are various manufacturers of Remote Power Controllers. The manufacturers and pertinent technical data relating to the RPCs are listed in Table 5-4. Detailed specifications are available from the manufacturers. Other manufacturers, other than those listed, indicated that they had active, in-house development programs for RPCs.

5.3 POWER CONDITIONERS

There are numerous suppliers of spacecraft dc/dc power conditioners. Most power conditioners for spacecraft usage are designed for input voltages within the range of 22 to 50 Vdc. Various power conditioner manufacturers have built power conditioners utilizing an HVdc bus for aerospace and terrestrial application. The design of off-line high efficiency power conditioners is common practice in the industry. The input voltage levels range between 100 to 300 Vdc. The lessons learned and techniques in off-line (utility power) power conditioner design are applicable to HVdc spacecraft power conditioner design.

The design techniques for HVdc power conditioners are similar to the 28 Vdc designs used in spacecraft. For HVdc designs, higher voltage input components are required in the input side of the power converter. The design techniques used for high voltage, high efficiency power conditioners, particularly in the control of radiated and conducted EMI and the protection of the supply from voltage transients and faults, are similar to that for the design of lower voltage power conditioners. Examples of both high and low input voltage designs (270 Vdc and 28 Vdc) are shown in Table 5-5 and Figures 5-6 and 5-7.

Table 5-4. Remote Power Controllers (RPC)

Manufacturer	Current Rating A	Features	Volt- age Rating Vdc	Size, in.	Weight, oz
Teledyne Solid State [5-14, 5-15]	2,5,10, 15,20, 50	Load switching, overload pro- section, remote control, built- in-test	270	Eurocard format	NA
Leach Relay [5-16]	2,5,10, 2,5,7.5	Load switching, overload pro- section, input- TTL compatibil- ity, current limiting	270	1.7 x 1.6 x 0.4	1.7
			150	1.8 x 1.6 x 0.6	1.5
Rockwell [5-17]	1,2,5	Overload pro- section, load switching, remote control, built-in-test	270	1.5 x 0.5 x 0.2 Hybrid design	NA
Kilovac [5-18 and 5-19]	4	Overload pro- section, load switching, remote con- trol, status indicated	270	3.25 x 1.5 x 2.2	9
	100		3.75 x 2.0 x 2.2	14	
Westinghouse [5-6, 5-20, 5-21, 5-22]	5	See optional requirements	120	1 x 1 x 1.71	3.3
	30		120	3.24 x 3.64 x 1	7.2
	1	Load switching projection cur- rent limit, remote control, built-in-test	300	2 D x 1.1	3.5
	2		300	2 D x 1.1	3.5

Table 5-4. Power Controller (RPC) (Cont'd)

Optional Requirements

- a. Steady state current rating of 5 A at 120 ± 12 Vdc.
- b. Voltage drop across the RPC at rated current is to be less than 1.0 V.
- c. Inverse trip time delay, T, must satisfy $(I^2 - G^2)T = 20 A^2$ seconds ± 5 percent for I greater than 6 A.
- d. The RPC is to limit the maximum load current to three times current (3x) up to 0.1 s before interruption. This 3x level is to be constant with respect to supply line (bus) voltage variations.
- e. Output rise time and fall time are to be between 10 to 10,000 μ s.
- f. EMI generation and susceptibility are to be minimized. Control and power circuits are to be dielectrically isolated.
- g. Operating temperature: -55°C to 100°C .
- h. Power losses are to be minimized.* Off-state leakage current is to be less than 5 mA. The RPC is to provide remote status indication of the open or closed states.
- i. Weight is to be minimized.
- j. Failsafe I^2t is to be $625 A^2$ - seconds for a current greater than 5x.

*Power loss in an RPC is important since system efficiency is affected. A voltage drop of less than 1 Vdc for a device rated at 120 Vdc has a power loss of less than 0.9 percent. This level is achievable. Where FET solid state devices are used, lower power losses are achievable.

Power conditioner efficiency improves in high voltage designs since forward drop in semiconductors is a lower percentage of input voltage. In addition, higher output voltages result in more efficient converters for the same reason.

Table 5-5 shows several commercially available low mass, high efficiency power supplies. Power density is up to 50 W/in^3 and efficiencies of up to 85 percent at 5 Vdc output. Figures 5-6 and 5-7 are photographs of power conditioners developed at TESLaco and Boeing Electronics Co. Figure 5-6 shows a 270 Vdc, 100 W converter built by TESLaco for Hughes Aircraft. Figure 5-7 shows a hybridized design of similar topology built by Boeing Electronics Co. for 28 Vdc input and 50 W output.

At high power levels (50 kW), at an input voltage level of 100 Vdc, the efficiency is 95 percent (see Table 5-5, Space Power Inc.).

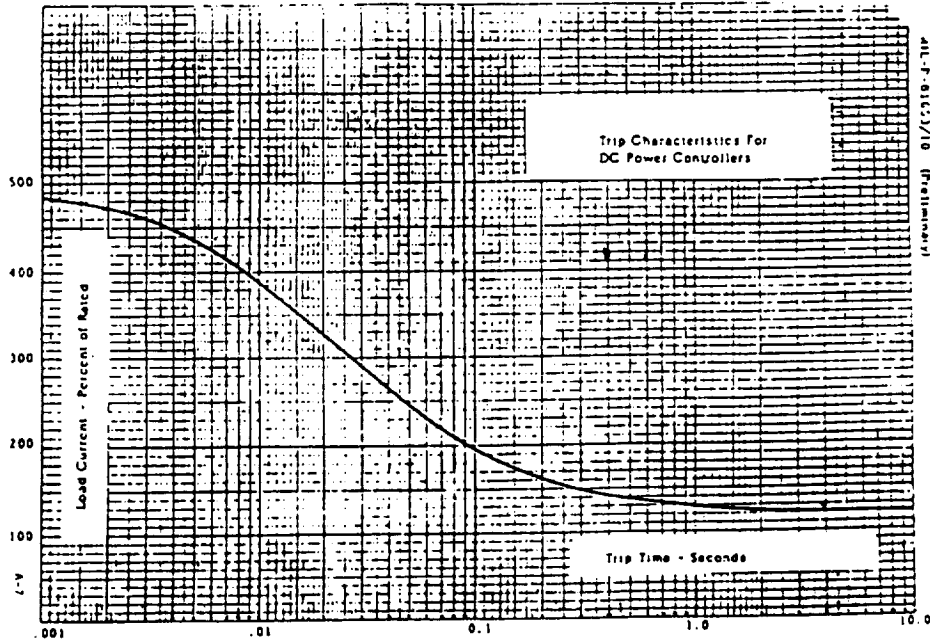

Figure 5-5. Trip Characteristics for RPC [5-20]

Table 5-5. Power Conditioners (dc/dc Converters)

Mfr	Power Rating (W)	Efficiency %	Input (Vdc)	Output (Vdc)	Output Current (A)	Size in ³	Power Density W/in ³
TESLaco [4-4]	100*	85**	300	5	20	3	30
Inland Motor [5-23]	100	78-83 depending on output voltage	135 270	As req'd. 5,12,15, 28,48	Depending on power rating	4.6	50
Space Power Inc. [5-24]	50 kW	95	100	>100		167	300

* See Appendix C
 ** This unit was built for Hughes Aircraft Co. which currently manufactures a line of power conditioners using this topology.

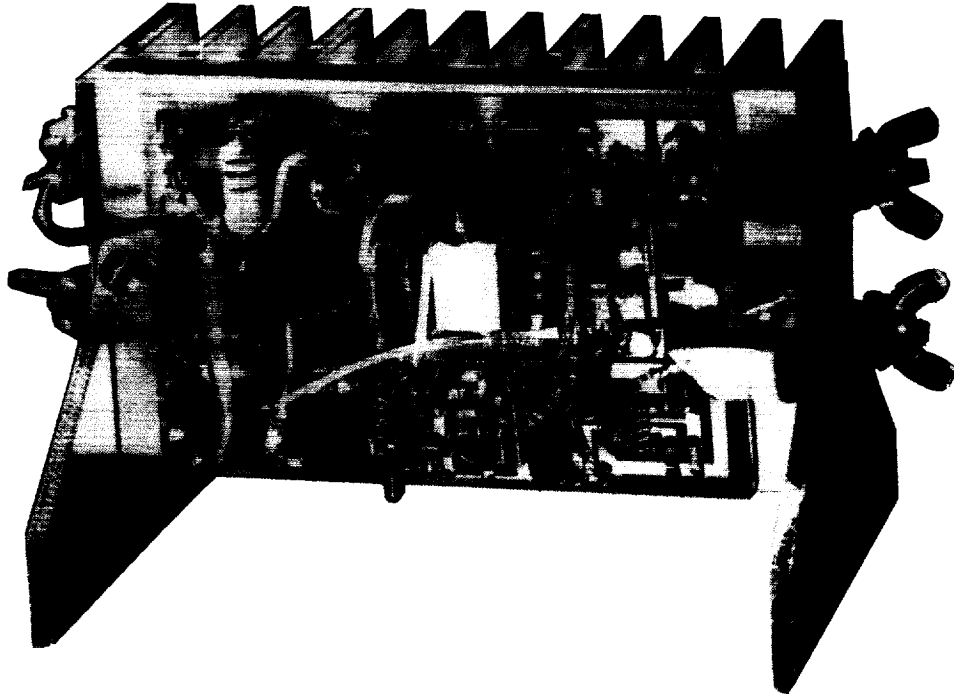

Figure 5-6. TESLaco 100 W, 270 V to 5 V Switching Power Supply
(3 in. x 2 in.)

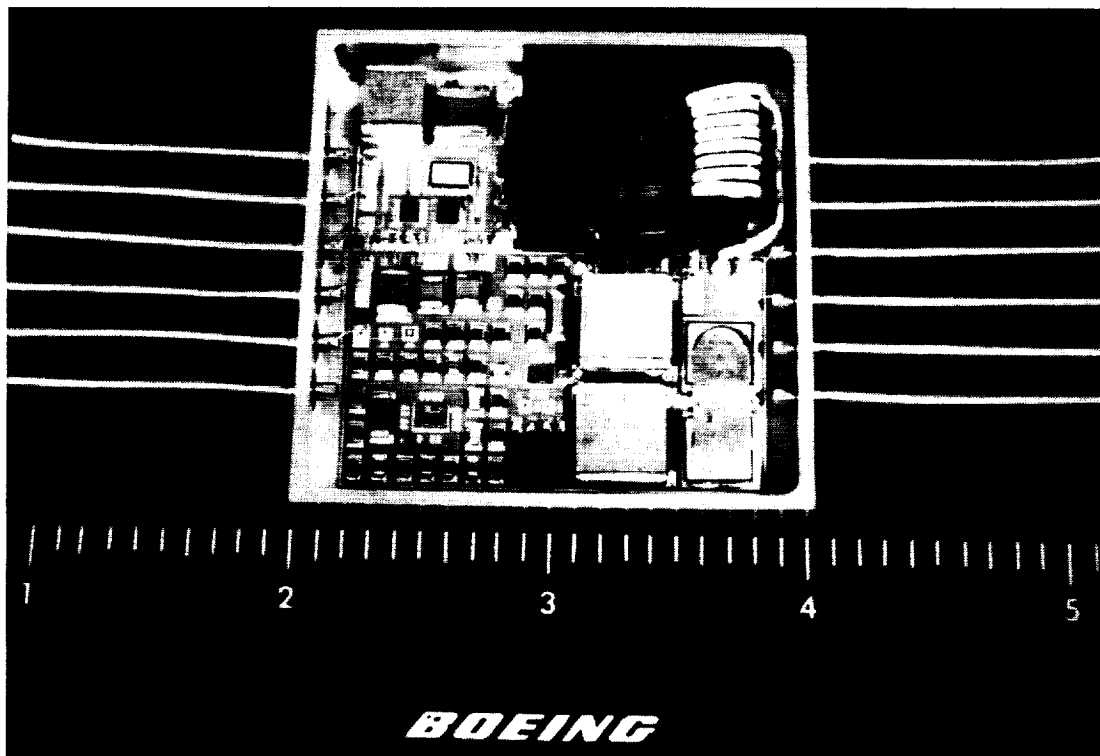

Figure 5-7. Boeing Electronics Company 50 W, 28 V
to 5 V dc/dc Converter Hybridized

The values of efficiency for the power conditioners described (see Appendix C and Table 5-5) are confirmed in estimates made by ESA for similar units (Appendix B). In general, as the input and output voltage of a converter increase, efficiency will improve due to semiconductor losses becoming a smaller percentage of total power.

A review of the state of the art of high frequency switching power conditioners is provided in Appendix C. In Appendix C special emphasis is placed on high power density, high efficiency, light weight, state-of-the-art performance parameters, as well as multiple-output configurations. The cost of the high power density converters is also discussed. This review of the state-of-the-art technology in the switching dc/dc converters clearly shows that very high power density power converters can be made with present day components. These converters approach 50 W/in³, operating at efficiencies of 85 to 90 percent, and result in lightweight units (approaching 450 W/lb). Increased switching frequency from 100 kHz to 500 kHz for the power range from 2 kW to 20 W leads to a side benefit of considerably improving the bandwidth to 20 kHz, as well as step-load transient response settling time to less than 100 μ s. In addition, the use of switching frequencies beyond 100 kHz allows the replacement of electrolytic and tantalum capacitors by film capacitors. This results in higher levels of power conditioner reliability.

5.4 dc BUS REGULATOR

A dc bus regulator can be used to regulate the voltage of an unregulated dc bus or to provide adjustable voltage dc to a load. The dc bus regulator differs from the power conditioners in Section 5-3 in that electrical isolation is not used. Using switch-mode processing techniques, regulation and transformation of dc voltage levels may be achieved with efficient energy conversion. Available high speed switching devices such as the power MOSFET enable the use of high switching frequencies - which in turn allows for reduced magnetic and filter masses.

A dc bus regulator rated at 20 kW has been developed by Space Power Inc. to power an electric propulsion thruster (arc jet) proposed for the SP-100 space vehicle (Table 5-6). A 150 W bus regulator developed for Aeroenvironment Inc. was used as an array shunt regulator for a photovoltaic-propelled electric vehicle (GM-SUNRACER) [5-25].

The power levels shown in Table 5-6 can be scaled to satisfy most Space Station requirements. These include power controllers for charge controller, discharge controller, heater loads, resistive loads, and other loads that do not require electrical isolation. An example of a dc bus regulator is shown in Figure 5-8.

5.5 ac MOTOR DRIVES

Various types of ac motor drives have been developed for aerospace applications [5-26]. These drives generally include an inverter operating with an input in the range of 22 Vdc to 42 Vdc. The design consideration in increasing the input dc voltage level to the HVdc requirements is similar to

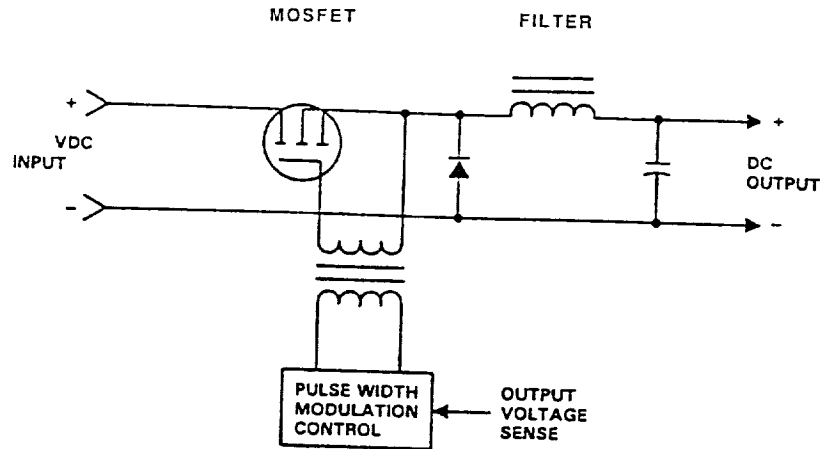

Figure 5-8.* dc Bus Regulator (buck type)

that discussed in the previous section on power conditioners. This class of inverters does not use electrical isolation between the dc bus and motor load, since the motor provides the electrical isolation desired for safety reasons.

A class of inverters has been developed for controllers/actuators. The actuators/controllers are basically dc brushless type systems. They are designed for operation without electrical isolation. Many ac motor controls in terrestrial and aerospace applications do not require electrical isolation for performance or safety considerations. The net result of elimination of the transformer (electrical isolation) is an improvement in efficiency and reduction in mass.

A new class of solid state dc/ac inverters using high frequency switching and PWM control has been developed that is applicable to the space environment as shown in Table 5-7. This table shows what can be achieved using advanced semiconductor devices and advanced techniques in PWM. These techniques utilize digital control of voltage and current waveforms [5-27]. These controllers use a combination of high voltage integrated circuits and high efficiency power switching devices [1-7]. Advance packaging techniques reduce voltage spikes and provide effective heat transfer. Most notable aspects of these motor drives are the high efficiency range (92 to 97.5 percent) and their low mass.

*The buck regulator is a pulse width modulation (PWM) type in which the power transistor (MOSFET) is switched on and off at a variable rate to provide an adjustable output voltage. The output filter averages the pulses produced and provides a filtered output. When voltage is transformed down, the efficiency of the dc bus regulators is in the range of 96 to 98.5 percent (Table 5-6) and confirmed in estimates made by ESA for similar units (Appendix B).

Table 5-6. Characteristics of dc Bus Regulators

Mfr.	Power Rating	Input Voltage (Vdc)	W/in. ³	Efficiency, %	Weight, lb
Aeroenvironment Inc. [5-25]	150 W	140-250	20	98.5	0.6
Space Power Inc. [5-28]	20 kW	120-150	120	96.0	5.0

Table 5-7. ac Motor Drives

Manufacturer	Rating kW	Input Voltage (Vdc)	Switching Element	Maximum Output Freq'y, Hz	Efficiency, %	Size, in.	Weight, lb
Aeroenvironment Inc. [5-25]	5	120	FET	500	97.5	14 x 16 x 2	8
General Electric [5-29]	12	270	IGBT	400	92	2 x 6 x 8	8
JPL [5-30]	35	240	Bipolar Transistor	400	97	16 x 12 x 6	42

The above three designs use a six-element bridge type of inverter. A schematic of the inverter of the General Electric design is shown in Figure 5-9. It should be noted that the six switching elements perform both the waveform synthesis function and the voltage control function.

The switching devices used differ according to the design. All of the above designs can be modified to utilize the new MOS-controlled thyristor (MCT) that is currently under development at General Electric Company with initial production units soon to be available [5-31]. It is expected that the usage of the MCT will provide improved inverter characteristics.

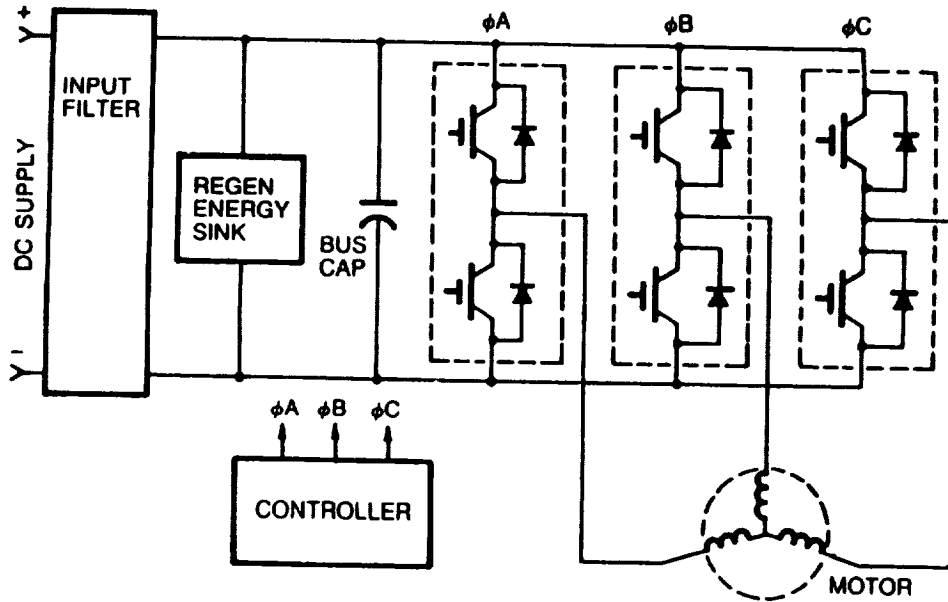

Figure 5-9. Basic Inverter Circuit Diagram

Figure 5-10 is a block diagram of the General Electric motor controller used to drive an electrostatic hydraulic or electromechanical actuator [5-29]. It should be noted that a high level of electronics integration of drive and control devices is utilized. The control strategy is implemented by using high voltage integrated circuits (HVIC) logic and digital signal processing systems. These controllers can be constructed using various power semiconductor devices such as IGTs, MCTs and MOSFET devices. The motors used can be of the permanent magnet ac type, switched reluctance, or brushless dc type.

Since the inverter has six switching elements, inverter reliability is high (due to low parts count). Tens of thousands of these inverters have been built for commercial, aerospace, and military applications. Resonant converters that are bilateral have a very high power semiconductor parts count and a comparatively complex logic circuitry. Therefore, a comparative study of the PWM vs the resonant synthesized waveform inverter should be made to determine the optimal design choice.

Typical motor control/inverter characteristics are as follows:

- o Input dc voltage: up to 300 Vdc operation
- o Power rating: up to 50 kVA
- o Voltage and frequency is regulated
- o Microprocessor control
- o Short circuit proof

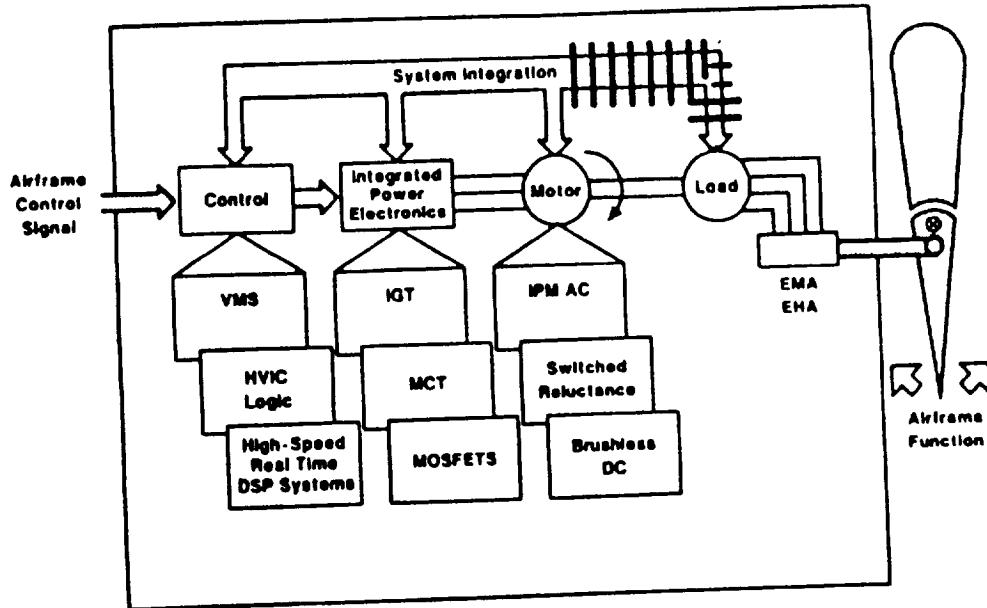

Figure 5-10. Integrated Actuator System [5-29]

- o Current limiting
- o Bilateral operation
- o Wide range of leading and lagging power factors
- o Constant torque, constant power operation capability
- o Reversing
- o Dynamic braking
- o Interface to spacecraft data bus
- o Soft start

5.6 SENSORS

Two types of sensors offer provisions for ensuring proper system control and system protection. These sensors are dc current sensors and ground fault sensors. The types and characteristics of various sensors are given below.

5.6.1 Current Sensors

A means of measuring dc bus current that is electrically isolated from the main dc bus is desirable for system protection, monitoring, and control [5-32]. Several available sensors are shown in Table 5-8. The Micro Switch and the Liasons Electroniques sensors are stand-alone types and can be used in any part of a spacecraft for monitoring dc bus current. Their frequency response is in the low microsecond region.

Table 5-8. dc Isolated Current Sensors

Manufacturers	Current Rating, A	Current Rating Size, in.	Weight, oz
Liaisons Electroniques [5-34]	1-1000*	1.5 x 0.625 x 0.75 /50 A	1
Micro Switch [5-35]	1-1000*	2.26 x 0.5 x 2.26 /950 A	1.3
JPL [5-36]	800	1 x 0.5 x 0.652 /800 A	0.75
*Various sizes in this range			

Another type of sensor developed at JPL is integratable in a smart power/high voltage integrated module and can be utilized as part of RBI, RPC, or power supply assemblies.

5.6.2 Ground Fault Sensors

Ground fault sensors for dc systems have been used in terrestrial photovoltaic systems and other military applications. A ground fault sensor developed for a 270 Vdc Naval Air Development Center (NADC) aircraft to provide sensing for cable faults is manufactured by Rockwell International Inc. [5-33]. The size of the sensor is 2 in. x 4 in. x 4 in., and it weighs 8 oz. Work performed for terrestrial photovoltaic systems array applications included a dc ground fault detector required for safety purposes [5-37].

SECTION 6

FLAT CABLE IN ELECTRICAL POWER DISTRIBUTION SYSTEMS

Flat cable has been considered by the Naval Air Development Center (NADC) for inclusion in aircraft with 270 Vdc operation [6-1, 6-2]. The results of a study conducted for NADC indicated the following:

- (1) While additional investigation is required, initial investigations indicated that cable shield and components are available to meet aerospace quality environments.
- (2) Flat conductor cable will tolerate even higher current densities than predicted in previous studies.
- (3) Most environmental factors do not have a significant adverse impact on the thermal performance of flat conductor cable. Consideration should, however, be given to current derating for cable shielding, cable folds, and altitude.
- (4) Flat cable harnesses can be manufactured following most standard processes, and in a timely manner.
- (5) No significant problems are encountered in installation of a complete flat cable harness.

The application of flat bus cable in high power/voltage spacecraft is intended to replace round wire for 120 to 160 Vdc operation. Flat bus produces a 40 percent decrease in mass compared to round cable due to increased radiation surface area. Therefore, for the same mass of flat cable compared to round cable, improved efficiency can be expected, due to reduced temperature rise in the cable. An alternate to improve efficiency is to maintain relatively the same cable temperature compared to round cable, and thereby reduce cable mass. The choice is dependent on system cost and mass modeling.

Flat bus cable does not exhibit any EMI characteristics that would prevent replacement of round cable [6-3]. The large capacitance of flat cable will improve the EMI characteristic of the bus cable in dc systems. Inductive fields generated on the cable feeding a load has that field cancelled by the current being returned from the load. Flat cable tends to separate at the point of cable shorting due to the high opposing flux field generated. This characteristic helps the cable to become self-protecting. The net effect of this is to reduce interaction between the cable and other components in the spacecraft. In addition to this, the large capacitance of flat cable (due to parallel plate conductors) will improve the EMI characteristic of the bus cable, due to the shunting action of the cable capacitance.

It should be noted that the capacitance of the cable actually stores energy that can be used to feed loads that require high rates of current rise. In an ac system, the capacitance of the cable draws reactive energy from the inverter source, resulting in additional power being dissipated in the cable and

power conversion components. In addition, the inverter and its output transformer must be increased in kVA capacity to handle the reactive requirements of the bus capacitance.

Connectors for flat bus cable are being developed for Space Station usage. Manufacturers such as Gore Inc. and G & H Technology Inc. produce connectors for flat cable.

SECTION 7

RELIABILITY

Since the high voltage dc spacecraft secondary distribution bus has similarity with its low voltage counterparts and HVdc aircraft [5-33], it can be expected that using the same ground rules of design, the reliability will be equal or better. Improved reliability for HVdc systems can be expected (compared to present generation spacecraft) due to reduced parts count and elimination of electromechanical switches [5-33]. In addition, reliability will also be improved by incorporation of high voltage power integrated circuits and advanced semiconductors that have been qualified for space application (including single event upset phenomena).

The reliability of a power conversion subsystem is dependent on the following elements of design.

- (1) Thermal stress.
- (2) Electrical stress.
- (3) Parts count (complexity).
- (4) Selection of parts (class of part).

Improved reliability is dependent upon thermal stress. The operating temperature of a power conversion device is dependent on heat dissipation, mass, radiating area and cooling methods. Improved reliability generally relates to increased size and mass. Establishing an optimum relationship between reliability and size and mass is the design goal for a power conversion subsystem.

Because of the limited production of HVdc components, mean time between failure (MTBF) data is limited in availability [7-1]. Available data for HVdc components is shown in Table 7-1.

Table 7-1. Component Reliability

HVdc Components	Reliability Characteristics
Solid State Switches	10^5 -3 x 10^5 Switching Cycles
Hybrid Switches	10^4 -5 x 10^4 Switching Cycles
Power Conditioners	10^5 MTBF (h)

SECTION 8

EMI CONSIDERATIONS

Low voltage spacecraft have been built, tested, and flown with power ratings up to 4 kW. These spacecraft have been designed and tested to specified EMI specifications. Many spacecraft have been qualified to MIL-STD-461B.

The usage of solid state or hybrid switches which can limit rate of rise and fall times and eliminate arcing will reduce EMI for dc systems since EMI characteristics are partially driven by switching and transients [8-1].

A key element is designing for low conducted current ripple in order to meet MIL-STD-461B. MIL-STD-461B specifies allowable current levels over a frequency band. It can be inferred that the conducted ripple current level of a power conditioner operating at 28 Vdc and 1 kW, will be similar to a 4.5 kW power conditioner at 126 Vdc. This is because the bus current and the power switches in the power conditioner will process similar current levels. Ripple voltages on the spacecraft bus will be higher because the bus source impedance will rise at approximately the same ratio as the voltage. Ripple voltage as a percentage of dc bus voltage will remain the same. If additional ripple voltage reduction is required additional filtering can be added. With the usage of flat dc bus cable which represents itself as a transmission line, additional conducted EMI suppression is provided due to the cable distributed capacitance [6-3]. It should be pointed out that the EMI filter component values for the low and high voltage spacecraft will be essentially the same, except for the higher EMI capacitor voltage ratings in the high voltage design. The issue of whether the radiated noise from the power conditioner will meet MIL-STD-461B is not known at this time, but the techniques of suppression should be similar to that used in the lower voltage designs [1-4]. The resolution of EMI issues for a high voltage dc bus distribution is well known compared to the resolution of EMI issues of a 20 kHz power distribution/component system.

With reference to the issue of radiated fields in an HVdc distribution system, it should be noted that with the absence of an inherent frequency in a dc system and with an inherently lower source impedance it can be expected that the dc system will have low levels of radiated electric and magnetic fields. This results from the fact that the distribution system will have negligible medium and high frequency signals. Radiated fields in the components such as power conditioners will be addressed with the same shielding techniques used in low voltage dc designs.

Electric and magnetic field radiated energy is a problem requiring resolution in an ac distribution system.

SECTION 9

SAFETY CONSIDERATIONS IN HIGH VOLTAGE dc SYSTEMS

Principal safety hazards are fire, shock, and audible noise. Dc systems are typically immune from audible noise due to designs above the audible range.

Fire hazard is common to all distribution systems, irrespective of the distribution frequency. The RBIs and RPCs detailed in this report can quickly clear major faults and thereby reduce fire hazards.

Shock level is related to current passing through the body. Current is dependent on voltage level, body resistance, and frequency [9-1]. Secondary distribution voltage level of 120 Vdc is sufficiently low and should not present a major hazard to personnel, when used in conjunction with ground fault sensors.

From a safety point of view, voltage and frequency do have an effect on perception and paralysis of humans. Sensitivity to touching a dc bus versus touching an ac bus varies with frequency. The worst sensitivity effects occur in the band from 60 Hz to 400 Hz. At similar voltage levels, the sensitivity to dc is approximately equivalent to that at 10 kHz. This is shown in Table 9-1, "Effect of Electric Currents on Cells and Tissues" [3-3]. No unusual safety problems at the 120 Vdc level were reported in the literature.

It should be noted that a 120 Vdc bus and a 20 kHz 208 Vac bus appear to be comparable with regard to shock hazard.

Table 9-1. Effect of Electric Currents on Cells and Tissue

Effect on Frequency (Hz) on Perception and Paralysis (fraction of 60 Hz effect)	
f(Hz)	Effect
0	0.2
10	0.9
60	1.0
300	0.8
1000	0.6
10,000	0.2
RF	0.01

SECTION 10

POWER MANAGEMENT AND DISTRIBUTION (PMAD) CONTROL SYSTEM (Contributed by Linda Palmieri)

PMAD control systems are well developed for aircraft applications [10-1]. Detailed specifications exist for control system components and bus protocols [10-2, 2-12, 4-3]. PMAD control systems are also well developed for LVdc spacecraft. A modern complex spacecraft PMAD system includes control of diverse elements such as power sources (PV and RTG), batteries, controllers, converters, and a complex network of remote load controllers consisting of hundreds of solid state relays [10-3]. Functions of PMAD include fault detection, fault isolation, load switching, current limiting, redundant bus management, management and control of power sources, storage and conversion subsystems, data management, communication, and system status. PMAD architecture and functions of the LVdc systems are applicable to HVdc systems, and the best way to understand them is to discuss an example of a modern PMAD system.

10.1 LOW VOLTAGE dc SPACECRAFT

Figure 10-1 is an example of a typical LVdc spacecraft power system. The 30 Vdc bus is driven by a combination of power sources including a radioisotope thermoelectric generator (RTG) and a solar array. Energy storage is provided by two identical secondary batteries. The power from these sources is distributed via branches of a power bus to the user loads (typically 28 to 30 Vdc). Solid-state switches (programmable circuit breakers) are used for connecting and disconnecting spacecraft loads to the power bus. These switches enhance command capabilities and increase telemetry data handling and monitoring requirements.

10.2 POWER GENERATION AND STORAGE

Maximum power capability of the RTG is approximately 310 W. The RTG is electrically connected to the 30 Vdc power bus through an isolation diode. The RTG electrical characteristics are monitored via telemetry conditioners in the Power Control Assembly. The solar array is typically divided into several segments. Each segment consists of groups of cells connected in a series-parallel configuration that facilitates rearranging their configuration to control voltage. A solar array switching unit (SASU) is capable of connecting or disconnecting any number of segments to or from the bus in response to a control signal generated by the shunt regulator.

Batteries, within their limitations, provide power in flight during those spacecraft activities where the power requirements of the user loads exceed the available RTG/Solar Array combined power. A bi-directional converter (BDC) handles charging and discharging of the battery in response to the control signal generated by the shunt regulator. When excess RTG/Solar Array power is available, the BDC is designed to begin charging the battery by providing appropriate voltage levels and charge rates. When the RTG/Solar Array power is insufficient to keep the power bus voltage regulated, the BDC discharges the

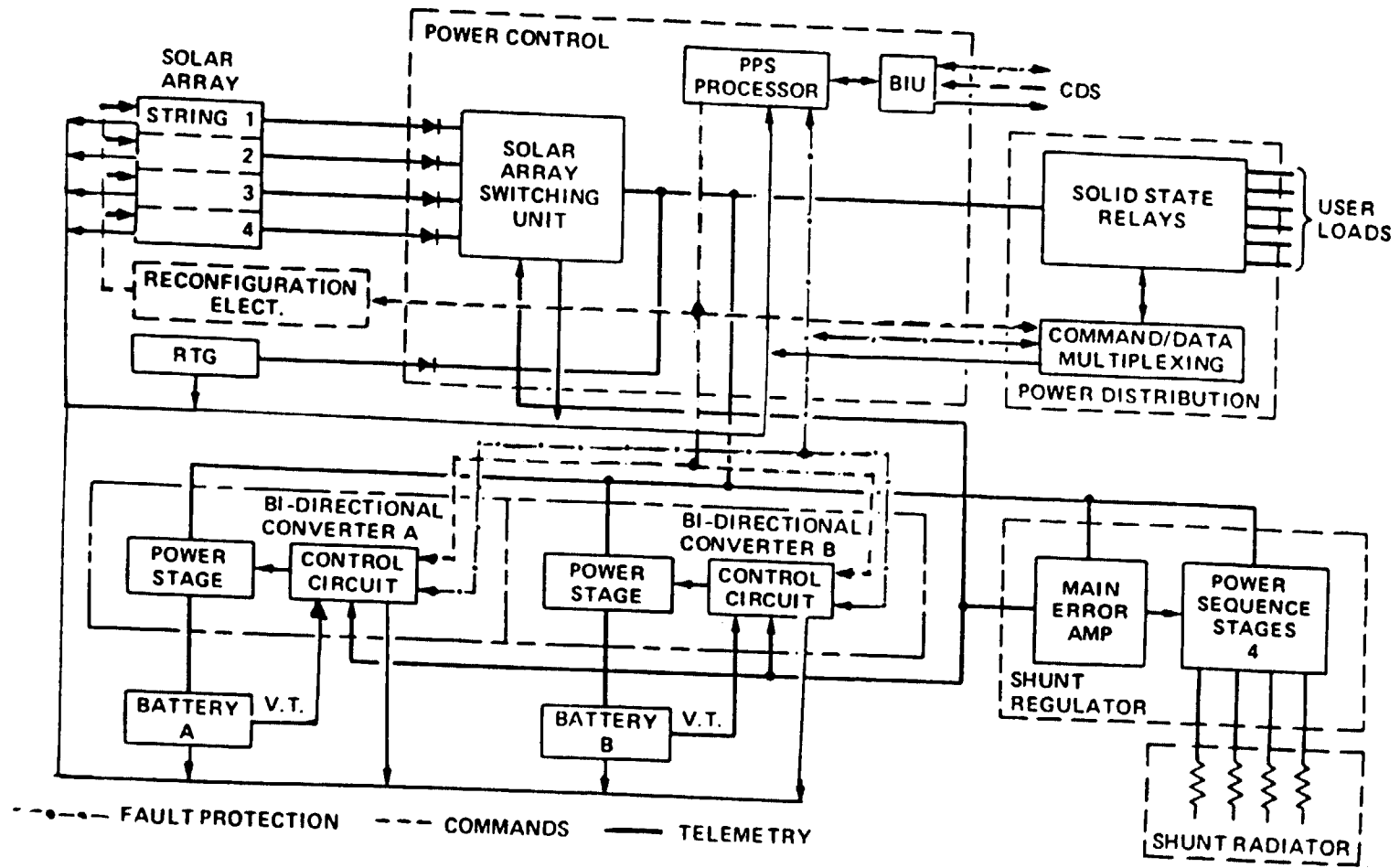

Figure 10-1. Power Processor Subsystem (PPS) Functional Block Diagram

battery at an appropriate rate to augment the RTG/Solar Array power and maintain an acceptable bus voltage. A transient current source (TCS), within the BDC, contains low-impedance, fast response circuitry through which the battery can be connected directly to the 30 Vdc bus in the event of a transient bus overload. A reduction in control voltage causes the BDC to respond using the TCS.

10.3 POWER REGULATION AND DISTRIBUTION

The shunt regulator unit provides regulation of the 30 Vdc bus by shunting excess RTG/Solar Array power from the 30 Vdc bus. This excess power is dissipated partly in power semiconductors within the shunt regulator package and partly in resistances external to the electronics equipment bays of the spacecraft. The shunt regulator develops a control voltage (CV) which is approximately proportional to the 30 Vdc power bus voltage. The CV is used to control the BDC, the transient current source, the SASU, and the shunt regulator currents. The shunt regulator is responsible for power regulation; however, the microprocessor is used for fault detection and response. That is, control of battery connection/disconnection to the power bus is hardwired controlled by the shunt regulator through the BDC. However, battery fault monitoring, detection, and response are managed by the microprocessor using software.

The Power Distribution Assembly (PDA) is an array of solid-state switches that are used to connect engineering/science loads (Figure 10-2). Each switch connects or disconnects an electrical load to the 30 Vdc bus in response to signals received from the microprocessor. The present solid-state switch configuration requires that both the power bus side (HIGH) and the return side (LOW) be simultaneously switched. The switching function must be immune to single-point failures that would result in a load being permanently on; therefore the switches are series redundant (HIGH and LOW sides). The switch incorporates a "soft" turn-on feature, load current limiting capability, and functions as a programmable circuit breaker. A series redundant current limiter and circuit breaker, with a fixed overload trip magnitude, is incorporated as part of the switch design. Each user load is supplied with parallel redundant switches within the PDA in order to prevent a single switch failure from resulting in the loss of connecting or disconnecting that load to the 30 Vdc bus. Specifically, there are two independent switches in the PDA that can be used to supply power to a single load. The internal microprocessor sends commands that are decoded in I/O board circuitry, to drive the solid-state switch to connect, disconnect, or reset the current limit value of the associated switch.

10.4 MICROPROCESSOR FUNCTIONS

A redundant microprocessor manages on-board command processing, telemetry collection, and fault detection and response. Command processing includes the receipt of a ground command and the forwarding of this command to the appropriate power system component. Examples of power commands include battery reconditioning, solid-state switch commands, and solar array reconfiguration commands. Telemetry collection involves sampling of all engineering data that are obtained/contained within the Power Processor Subsystem (PPS) and compressing these data to meet downlink transmission

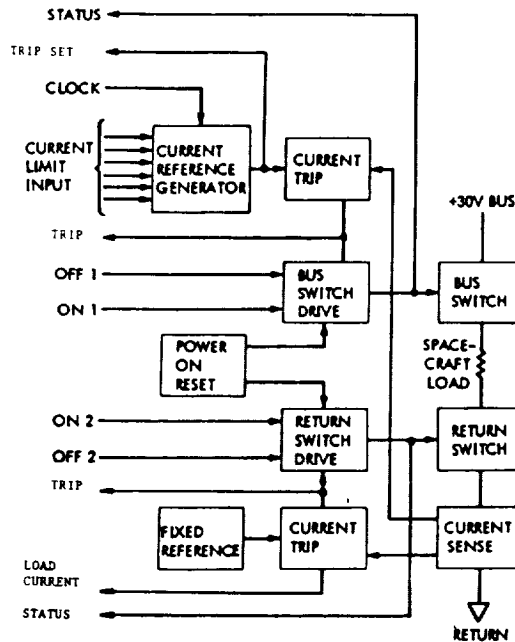

Figure 10-2. Hybrid Switch Block Diagram

requirements. PPS data are generated by many transducers located throughout the system. Analog sensors are used to measure voltages, temperatures, and currents. Digital sensors are used to monitor any PPS specific events. These data are used by the microprocessor to determine the state of health of the power system and to detect the occurrence of any faults. If a fault condition exists, the microprocessor initiates an appropriate fault response action, and reports the fault occurrence and its associated response to ground operations.

The combined use of the solid-state switches and the microprocessor results in greater flexibility of the power system. The microprocessor handles switch commanding, specifically turn-on and turn-off, and setting a current "trip" value. Within the switch electronics, this current value is compared to the load current and results in a switch turn-off if the load current exceeds the trip value. Telemetry from the switches is used by the microprocessor to detect switch related faults and proceed with an appropriate fault recovery routine. One example of a fault response is attempting to determine whether a switch turned off due to a failed switch, or an excess load current condition, or a load failure.

The microprocessor can be used to monitor battery telemetry, including temperature, voltage, and current. The microprocessor monitors these data for faults and calculates battery state-of-charge (SOC). SOC is critical for ground analysis purposes to determine when battery reconditioning is appropriate. The microprocessor has the on-board capability to change the voltage-temperature level in the event of certain battery faults. The microprocessor also interfaces with the bi-directional converter to command various VT levels for battery operations. The microprocessor is interfaced to

the solar array through reconfiguration electronics to provide the command capability to reconfigure the electrical configuration of the solar array segments.

Table 10-1 lists typical software modules that may be included in a microprocessor-based power system. Estimates of the size, in lines of C source code, are also listed. The total number of lines is 1420. These estimates are generated with knowledge gained from prototyping, in a development environment, the solid-state switch command functions. Command and telemetry collection modules in the power subsystem are less complex than modules of similar function in the command/data or guidance/control subsystems. Fault detection/response modules are more complex due to the relationship of the subsystems and the possibility of one subsystem's faults affecting another subsystem. An attempt to limit propagation effects of faults on other subsystems results in greater complexity of the subsystem fault protection software.

As more on-board capability is added to the power subsystem, the software size requirements will increase. On-board enhancements include battery monitoring and reconditioning, trend analysis, and power margin management. The increase of software modules not only accommodates for the added functionality but also provides for more complex fault.

10.5 CONCLUSIONS

The trend for unmanned planetary spacecraft is to connect/disconnect user loads through solid-state switches and to expand the on-board capability of the microprocessor to include functions that have been developed, tested, and verified on the ground. Such additional functions may be on-board battery reconditioning, trend and performance analysis of the power sources, and expanding the fault detection and response capability.

The control and fault protection schemes for manned spacecraft applications are similar to unmanned LVdc power systems in approach, however, more complex in application. Manned spacecraft systems, in addition to power regulation and distribution, must provide greater fault protection through increased redundancy and provisions for emergency power. These requirements support the primary manned spacecraft goal to provide an operating environment that supports human life.

Table 10-1. Power/Pyro Subsystem - Software Code Estimates

Function	Lines of Code
COMMAND MODULES	
Initialization (set-up of Solid-State Switches)	s
Command Validation (verify prior to execution)	s
Command Expansion	s
Solid-State Switch Commands	
ON/OFF	s
Set CURRENT LIMIT VALUE	s
Battery Reconditioning	m
Initiate Pyro Events	s
TELEMETRY COLLECTION MODULES	
Sample Solid-State Switch Analog Data	s
Sample Solid-State Switch Digital Data	s
Sample Battery Telemetry	m
Sample Bi-Directional Converter Data	s
Sample DC Bus Unbalance	s
Sample RTG Data	s
Packetize Telemetry Data	m
FAULT PROTECTION MODULES	
Microprocessor Self-Diagnostics (health check, status)	s
Battery Monitoring (State-of-Charge)	m
Solid-State Switch Monitoring	s
I/O Board Diagnostics	s
Solid-State Switch Trip Response	s
Solid-State Switch Failure Response	s
Battery Over/Under Current Response	s
Battery Over/Under Voltage Response	s
Battery Over/Under Temperature Response	s
Bi-Directional Converter Failure	s
I/O Board Failure	s
DC Bus Overload	
SYSTEM FAULT PROTECTION INTERACTION	1
Microprocessor OPERATING SYSTEM Implementation Modules	
Interrupt Service Routines	s
I/O Driver Routines	1
Other	1
<p>*1 100 lines of C source code m 60 lines of C source code s 30 lines of C source code</p>	

SECTION 11

CONCLUSIONS

- o Current technology will allow the development of an HVdc secondary distribution system for space application.
- o A large number of vendors have the technology and space qualification background to produce the required components and design of HVdc systems competitively. RCA has built and qualified a spacecraft with a 100 Vdc bus.
- o All components to build HVdc systems have been prototyped or developed for terrestrial and aircraft applications. Previous deficiencies in dc switching have been resolved. These HVdc components developed for aircraft applications are compact, low mass, high efficiency, and suitable for space environment development.
- o Qualification of most HVdc components for space application is still required.
- o Because of the use of HVdc for array and battery subsystems, a number of HVdc components have already been developed for space applications, including brassboards for Space Station.
- o There exists a substantial 28 Vdc to 50 Vdc spacecraft experience in the design of power management and distribution (PMAD) control systems. The prototype developments using MIL-STD-1553B control bus for aerospace applications have paved the way for HVdc PMAD systems for space station applications.
- o The extensive space experience in low voltage dc design heritage allows the development of procedures and components for EMI control, system stability, and grounding for HVdc systems.
- o Safety issues relating to HVdc are well understood. No unusual safety problems were reported in the literature.
- o Users are familiar with design techniques and applications of dc/dc converters and dc power controls which simplify user interface.
- o The simplicity, low parts count, and previous space qualification history of dc systems offer the potential of high reliability for space environments.

SECTION 12

REFERENCES

- 1-1. SPACE STATION PROGRAM DEFINITION REQUIREMENTS DOCUMENT (PDRD), SSP30000, Sect. 3, Rev. F, May 6, 1988
- 1-2. SPACE STATION ELECTRIC POWER SYSTEM REQUIREMENTS AND DESIGN, Fred Teren, 1987, IECEC Paper No. 879003
- 1-3. SPACE STATION INTERNAL COMMUNICATION FROM ESA, June 1986, D.M. O'Sullivan, J.E. Haines
- 1-4. JEM POWER SYSTEMS STUDY SPACE STATION INTERNAL COMMUNICATION, From National Space Development Agency of Japan (NASDA), April 1988
- 1-5. LETTER REPORT (Draft) PANEL ON ELECTRIC POWER SYSTEM OF AD HOC COMMITTEE ON SPACE STATION ENGINEERING AND TECHNOLOGY DEVELOPMENT, AERONAUTICS AND ENGINEERING BOARD, NATIONAL RESEARCH COUNCIL, June 1986
- 1-6. ANALYSIS OF THE IMPACT OF A 270 VDC POWER SOURCE ON THE AVIONIC POWER SUPPLIES IN THE S-3A AIRCRAFT, Naval Air Development Center Contract No. N62269-78-C-0007, Lockheed-Calif. Co., LR 28780, November 27, 1978
- 1-7. SMART POWER/POWER INTEGRATED CIRCUITS, Proceedings of Workshop Held May 1987 at California Institute of Technology, "Smart Power Applications in Power Actuation" by Dr. M Paparo
- 1-8. SMART POWER CHANGING THE FACE OF POWER CONTROL ELECTRONICS, April 28, 1988
- 2-1. POWER SYSTEM DESCRIPTION DOCUMENT (PSDD), (Station and Platform Systems) September 11, 1987
- 2-2. STC-DBS ELECTRICAL POWER SUBSYSTEM, S. R. Peck, T. Callen, P. Pierce, T. Wylie - RCA Astro-Electronics, Proceedings, 19th IECEC, 1984, Volume 1, pages 428-441
- 2-3. BATTERY INTERFACE DESIGN AND SIZING, D. Rusta, TRW, Proceeding of Annual Battery Conference on Applications and Advances, California State Univ., Dept. of EE, Long Beach, January 1986
- 2-4. TECHNICAL SPECIFICATION FOR THE SP-100 SPACE REACTOR POWER SYSTEM, Revision 7, September 18, 1987, by the SP-100 Program Office
- 2-5. SAE-AE7 PROCEEDING, April 20, 1988
- 2-6. ANALYSIS OF THE IMPACT OF A 270 VOLT dc POWER SOURCE ON THE AVIONICS POWER SUPPLIES IN THE P-3 AIRCRAFT AND THE EFFECT ON AIRCRAFT PERFORMANCE, Lockheed-California Co. Report No. NADC-81156-60, February 28, 1983

- 2-7. 270 VDC AIRCRAFT ELECTRICAL SYSTEM CONFIGURATION/DESIGN STUDY, Naval Air Development Center Report, Grumman Aircraft Systems Division, Interim Report 3EG-REEES-R-07, November 1987
- 2-8. SAE - AEROSPACE STANDARD No. AS 1931, "Electrical Power, High Voltage Direct Current, Aircraft, Characteristics and Utilization of"
- 2-9. INTEGRATED DIGITAL/ELECTRIC AIRCRAFT CONCEPTS STUDY, M. Cronin, et al., Lockheed-Calif. Co., NASA Contractor Report No. 3841, January 1985
- 2-10. SYSTEMS STUDY FOR AN INTEGRATED DIGITAL/ELECTRIC AIRCRAFT (IDEA), Boeing Commercial Airline Co. NASA Contractor Report No. 3840 - G.E. Tagge, L.A. Irish, and A.R. Bailey, January 1985
- 2-11. MEETING THE ELECTRIC POWER NEEDS FOR AIRCRAFT DIGITAL ELECTRONICS, I. Mehdi, Boeing Military Airplane Co., NAECON 1984
- 2-12. DESIGNING A FAULT TOLERANT ELECTRICAL POWER SYSTEM, M. Dige, P. Leong, D. Summer, NAECON, 1987, IEEE No. CH2450-5/87/0000-1483
- 2-13. ADVANCED ELECTRICAL POWER SYSTEMS TECHNOLOGY FOR THE ALL ELECTRIC AIRCRAFT, R. Finke, G. Sundberg, NAECON 1983
- 2-14. Personal communication with J. Fischer of NAVSEA and S. Krauthamer, JPL, March 28, 1988
- 2-15. Personal Communication, S. Krauthamer, JPL and P. Mizele of Newport News Shipbuilding Co., March 28, 1988
- 2-16. MILITARY STANDARD INTERFACE STANDARD FOR SHIPBOARD SYSTEMS, DOD-STD 1399 (NAVY) Section 390, Department of Defense, USA, November 20, 1986
- 2-17. Personal Communication, S. Krauthamer, JPL and D. Farmer of General Dynamics, Land Systems Division, May 1988
- 3-1. SECONDARY POWER DISTRIBUTION FOR SS, DOCUMENT ST-E-1000, National Space Development Agency of Japan, March 5, 1986
- 3-2. NASA-CR-1205 [1], Compendium of Human Responses to the Aerospace Environment, Vol. 1, Sec. 5
- 3-3. SPACE STATION GROUNDING STANDARD - JSC No. 30240, Space Station Program Office, July 2, 1986
- 4-1. CONCEPTUAL DESIGN OF AN ADVANCED AIRCRAFT ELECTRICAL SYSTEM, W. Owens, et al., NAECON 1987, IEEE No. CH 2450/87/0000-0441
- 4-2. Personal Communication - D. Pelhank of Douglas Aircraft Co. and S. Krauthamer of JPL, Re: Westinghouse Report "Smart Power Controllers for 270 Vdc Electric Power System," written for Douglas Aircraft Co., March 24, 1988

- 4-3. MILITARY SPECIFICATION MIL-P-81653C, PRELIMINARY, "General Specification for Power Controller," July 1986
- 4-4. LOW PROFILE, 50, W/in³, 500 kHz INTEGRATED MAGNETICS PWM ĆUK CONVERTER, S. Ćuk, California Institute of Technology; Z. Zhang, Lateef A. Kajouke, TESLaco-High Frequency Power Conversion Conference, May 1988
- 4-5. MILITARY SPACE POWER SYSTEMS TECHNOLOGY TRENDS AND ISSUES - R.R. Barthelemy and L.D. Massie, IECEC 1985, Paper No. 859035
- 5-1. BACKGROUND AND EXPERIENCE IN THE DEVELOPMENT AND APPLICATION OF RPCs - REMOTE POWER CONTROLLERS, Westinghouse Electric Corporation
- 5-2. AN INTRODUCTION TO HIGH VOLTAGE dc CONTACTORS, Hartman Electrical Co.
- 5-3. Written Communication - From P. Theisen, Eaton Corp., Cutler Hammer Division to S. Krauthamer, JPL, Re; Contactors, May 1988
- 5-4. ADVANCED LINE CONTACTOR FINAL REPORT, ID No. 6Y128, C.B. Hassan, Lockheed Advanced Marine Systems, San Diego, June 3, 1986
- 5-5. 270-V dc HYBRID SWITCH, P. Theisen, S. Krstic, Eaton Corporation, IEEE Transactions, Vol. CHMT-9, No. 1, March 1986
- 5-6. HIGH VOLTAGE dc SWITCHGEAR DEVELOPMENT FOR MULTI-KW SPACE POWER SYSTEMS WAED, Report 81-05E, NASA-CR-1654137, Westinghouse Electrical Corporation Electrical Systems Division, November 1981
- 5-7. Written Communication - from R. Johnson, Teledyne Kinetics to S. Krauthamer, JPL, Re: Hybrid Interrupters, April 31, 1988
- 5-8. HIGH VOLTAGE dc SWITCHGEAR DEVELOPMENT FOR MULTI-KW SPACE POWER SYSTEMS - W. Billings, Westinghouse Electrical Corp. Electrical Systems Division, NASA CR-165413, WAED-81-05E
- 5-9. REMOTE BUS ISOLATOR, Specification No. ED406490-1 150 AMP - 160 Vdc, Westinghouse Electric Corp., Electrical Systems Division, April 25, 1988
- 5-10. SOLID STATE CIRCUIT BREAKER, Specification No. RV-52157, Lockheed Missiles and Space Co., January 9, 1981
- 5-11. CURRENTS, Westinghouse Electrical Corp. Spring 1986
- 5-12. SPECIFICATION: POWER CONTROLLER, 270 Vdc, LOAD SWITCHING, SPST, NORMALLY OPEN, 1, 2, AND 5 AMPERES, NADC SPECIFICATION No. TS-8001/07
- 5-13. BACKGROUND AND EXPERIENCE IN THE DEVELOPMENT AND APPLICATION OF RPCs - REMOTE POWER CONTROLLERS, Westinghouse Electric Corp.
- 5-14. TELEDYNE SOLID STATE 1988 DATA BOOK - Teledyne Solid State Division of Teledyne Relays

- 5-15. REMOTE POWER CONTROLLER - Product Control Dwgs., for 2, 5, 10, 15, 20, 50 AMP Devices [CF001102M4A, M5A, M10A, M15A, M20A, M50A - Teledyne Solid State
- 5.16. INTELLIGENT SWITCHING DEVICE (ISD), SSPC (DC-SPST-NO), Leach Corp. and Personal Communication, S. Krauthamer, JPL and S. Atreya of Leach Corp., March 30, 1988
- 5-17. SOLID STATE 270V dc AIRCRAFT POWER CONTROLLERS (N62269-84-R-0249), Rockwell International - Autonetics Strategic Systems Division
- 5-18. POWER CONTROLLER KPC 1; KPC 2 - Kilovac Corp.
- 5-19. VACUUM REMOTE POWER CONTROLLERS FOR HIGH CURRENT, HVDC, AEROSPACE POWER DISTRIBUTION AND LOAD CONTROL APPLICATIONS - H. Jabaghorian, Kilovac Corp, Fourth S.A.E. Aerospace Interconnect Systems Conference, October 1987
- 5-20. AEROSPACE TECHNOLOGY DEVELOPMENT OF SOLID STATE REMOTE POWER CONTROLLERS FOR 300 VDC WITH CURRENT RATINGS OF ONE AND TWO AMPERES ONE TYPE HAVING CURRENT LIMITING, W. Billings, Report No. NASA CR-135199 (WAED 77-01E), Westinghouse Electrical Corp., June 1977
- 5-21. KILOVOLT dc SOLID STATE REMOTE POWER CONTROLLER DEVELOPMENT - Final Report - J. Mitchell, Report No. NASA CR 168041, WESDL-82-07E, Westinghouse Electric Corp., October 1982
- 5-22. EXERPT FROM WESD REPORT on NASA Contract NA53-17771 covering development of 120 Vdc RPCs, Westinghouse Electric Corp.
- 5-23. Personal Communication: A. Hilbert of Inland Motors and S. Krauthamer, JPL, April 6, 1988, Re; Power Conditioners
- 5-24. Mid Voltage Power Conditioning, S. Wong, Space Power Inc., Report No. F33615-86-C-2674, January 1987
- 5-25. Personal Communication, S. Krauthamer, JPL and A. Coconi of Aeroenvironment Inc., Re; dc/dc Converters and ac Motor Drives, May 1988
- 5-26. THE SECOND ELECTRONICS REVOLUTION: THE IMPACT POTENTIAL OF NEW POWER ELECTRONIC TECHNOLOGY ON AIRCRAFT ACTUATION SYSTEMS, J. Lyford, GE (ACSD), NAECON, 1986, IEEE No. 0547-3578/86/0000-0386
- 5-27. PHOTOVOLTAIC POWER CONDITIONING SUBSYSTEM: STATE-OF-THE-ART AND DEVELOPMENT OPPORTUNITIES, S. Krauthamer, et al., Jet Propulsion Laboratory, JPL Pub. 83-81, January 1984
- 5-28. PERSONAL COMMUNICATION, S. Krauthamer, JPL and N. Britt of Space Power Inc., May 1988
- 5-29. INTEGRATED ACTUATOR SYSTEM, GE Aircraft Control Systems Department, General Electric Co., Report No. 525-787

- 5-30. HIGH PERFORMANCE VEHICLE INVERTER REPORT, W. Rippel, D. Edwards, JPL, November 1984, JPL D-2199
- 5-31. MOS CONTROLLED THYRISTORS (MCTs) IN ENERGY SYSTEMS, V. Temple, GE Corporate R&D, IECEC 1987, Paper No. 879252
- 5-32. SURVEY OF HALL EFFECT LINEAR OUTPUT TRANSDUCERS, S. Krauthamer, JPL, Internal Document, November 1987
- 5-33. FLAT BUS FAULT SENSORS, C. Linder, NADC 77336-60, October 1979, Rockwell International Autonetics Strategic Systems Division
- 5-34. THE LEM MODULE, LEMSA (see Appendix A)
- 5-35. SPECIFIERS GUIDE FOR SOLID STATE SENSORS, Copy 20 Issue 8, Micro Switch Inc.
- 5-36. A HIGH PERFORMANCE, INTEGRATABLE CURRENT SENSOR, W. Rippel, JPL, Power Conversion International, August 1987
- 5-37. SAFETY RELATED REQUIREMENTS FOR PV ARRAY AND MODULE, A. Levins of UL, JPL Report No. 955392-2
- 6-1. FEASIBILITY STUDY OF A 270 Vdc FLAT CABLE AIRCRAFT ELECTRICAL POWER DISTRIBUTION SYSTEM, M. Musga, R. Rinehart, Boeing Aerospace Corp., January 1982, Report No. NADC-82023-60
- 6-2. 270 Vdc AIRCRAFT FLAT CABLE DISTRIBUTION SYSTEM INITIAL HARDWARE IMPLEMENTATION AND TEST, D. Persons, M. Musge, Boeing Aerospace Corp., February 25, 1984, Report No. NADC-82033-60
- 6-3. TESTING AND EVALUATION OF THE ELECTROMAGNETIC CHARACTERISTICS PERFORMED ON THE STACKED FLAT BUS, David T. Brown Inc., April 20, 1984, Report No. NADC-85114-60
- 7-1. CIRCUIT PROTECTION FOR ADVANCED AIRCRAFT - A FUNCTIONAL AND HISTORICAL PERSPECTIVE, F. Cannovo, et al. Texas Instruments, SAE Paper No. 872502, Aerospace Avionics Equipment and Integration Conference, November 2, 1987
- 8-1. IMPACT OF POWER DISTRIBUTION ON THE SPACE STATION EMI ENVIRONMENT, C. Pistole, SAE/P-85, Paper No. 859218
- 9-1. ELECTRIC SHOCK SENSATION - THE EFFECT OF FREQUENCY, H. W. Turner and C. Turner, Electrical Review
- 10-1. GENERAL SPECIFICATION FOR CONTROL GROUP, MULTIPLEX ELECTRICAL DISTRIBUTION CONTROL, MIL-C-81883, Preliminary December 1986
- 10-2. MILITARY SPECIFICATION: GENERAL SPECIFICATION FOR CIRCUIT BREAKERS, TRIP FREE LOW SIGNAL REMOTE CONTROL, MIL-C-85814 July 1986, Preliminary

- 10-3. SPACE STATION 20 KHz POWER MANAGEMENT AND DISTRIBUTION SYSTEM, I.G. Hansen, G.R. Sundberg, NASA, June 23-27, 1986
- C-1. DESIGN OF A 2 KW, 100 KHz SWITCHING REGULATOR FOR SPACE SHUTTLE, A. Cocconi and S. Ćuk, TESLAcO-Optimum Power Conversion, Fifth International PCI, 1982
- C-2. DESIGNING A HYBRID 50 W/in³, 500 kHz CUK CONVERTER, Dr. S. Ćuk, Professor of Electrical Engineering, California Institute of Technology and Dr Z. Zhang, Chief Engineer, TESLAcO; Part II (Magnetics Optimization), Powertechnics Magazine, June 1988
- C-3. COUPLED-INDUCTOR ANALYSIS AND DESIGN, S. Ćuk and Z. Zhang, Power Electronics Group, California Institute of Technology, Power Electronics Specialist Conference Record, pp. 655-665 (IEEE Publication 86CH2310-1), 1986
- C-4. CAPACITORS - INTEGRATED CERAMIC COMPONENTS LTD, December 1987, Types 3740 and CC13 Specification Sheet
- C-5. PRODUCT ANNOUNCEMENT -- QUAD-OUTPUT 100-WATT dc/dc CONVERTERS DELIVER 18 WATTS/in³ Fabricated with hybrid construction techniques, these 500-kHz, low-profile converters operate over a 3:1 input voltage range and include emc filtering that meets the requirements of MIL-STD-461B, Class A1, Powertechnics Magazine, May 1988

SECTION 13

BIBLIOGRAPHY

ADVANCED ELECTRICAL POWER SYSTEM TECHNOLOGY FOR THE ALL ELECTRIC AIRCRAFT, R. Finke, G. Sundberg, NASA, NAECON 1983

AEROSPACE COUNCIL OF THE SAE TECHNICAL BOARD, MEMBERSHIP LISTS AND ORGANIZATION CHART, 1988

AIRCRAFT ELECTRICAL POWER SYSTEMS, E. Beauchamp, Airesearch Mfg. Co., NAECON, 1985

AIRCRAFT POWER SYSTEM TECHNOLOGY - LONG RANGE PLAN, J. Weimer Aero-Propulsion Laboratory, SAE-A37, April 20, 1988

AUTOMATED POWER MANAGEMENT - A TECHNICAL BRIEF, The Leach Corporation, April 15, 1988

CIRCUIT PROTECTION FOR ADVANCED AIRCRAFT - A FUNCTIONAL AND HISTORICAL PERSPECTIVE, Texas Instruments Aerospace Avionics Equipment and Integration Conf., November 2-4, 1987, Paper No. 87502

CIRCUIT PROTECTION FOR ADVANCED AIRCRAFT - A Functional and Historical Perspective - F. Cannaur, R. Peterson, C. Cobb, Texas Instruments, Aerospace Avionics Equipment and Integration, Proceedings of the Second Conference, Paper No. 872502

COMPARATIVE STUDY OF CABLE CONSTRUCTION FOR 20 KHz POWER DISTRIBUTION, W. Putney et al., IECEC 1987, Paper No. 879356

COSTING TOOLS FOR SPACE STATION TRADE STUDIES: POWER DISTRIBUTION SYSTEMS - L. Rosenberg, Jet Propulsion Laboratory, Report No. JPL D-3069, October 1986

DESCRIPTION OF A 20 KILOHERTZ POWER DISTRIBUTION SYSTEM, I. G. Hansen, NASA, August 25, 1986, IECEC 1986, NASA Technical Memorandum 87346

DESIGN CONCEPTS FOR A 5 kW dc TO dc SERIES RESONANT CONVERTER, J. Martin, W. Dudley, IECEC, 1987 Paper No. 87315

DESIGN CONSIDERATIONS FOR LARGE SPACE ELECTRIC POWER SYSTEMS, D. Renz et al., April 1983, NASA Technical Memorandum 83064

DEVELOPMENT AND TEST OF HIGH FREQUENCY dc/dc CONVERTERS FOR COMMUNICATIONS SATELLITES - W. Alsbach, N. Tsuya, T. Gohnai, SAE - 1985 Paper No. SAE/D-85/164-859467

ELECTRIC POWER MANAGEMENT AND DISTRIBUTION FOR AIR AND SPACE APPLICATIONS - Byron Mehl and Eric Henderson, IECEC 1985 Paper No. 859355

HIGH VOLTAGE DESIGN GUIDE: SPACECRAFT, W. Dunbar, Boeing Aerospace Company, Report No. AFWAL-TR-82-2067, January 1983

HIGH VOLTAGE dc STABILITY ANALYSIS MODELS VERIFICATION, D. Sommer, T. Liang, Boeing Military Airplane Co. Report No. NADC-82034-60, February 1984

HIGH VOLTAGE dc STABILITY ANALYSIS MODELS, D. Sommer, I. Mendi, Boeing Military Airplane Co. Report No. NADC-79048-60, February 1981

INCIPIENT FAULT DETECTION AND POWER SYSTEM PROTECTION FOR SPACEBORNE SYSTEMS, B. Russell, I. Hackler, IECEC 1987, Paper No. 879349

INTEGRATED MAGNETICS VERSUS CONVENTIONAL POWER FILTERING, S. Ćuk, Power Electronics Group, California Institute of Technology, Intelec 87, June 1987

INTEGRATED MAGNETICS, QUASI-RESONANT ĆUK DC-TO-DC CONVERTER, S. Ćuk, D. Maksimovic, Power Electronics Group, California Institute of Technology, High Frequency Power Conversion Conference, May 1988

MANNED SPACE STATION ATTACHED ACCOMMODATIONS HANDBOOK, PART 6, NASA Goddard Space Flight Center, November 20, 1987

MILITARY SPECIFICATION: GENERAL SPECIFICATION FOR SWITCHES, TRANSDUCER, MIL-S-85772(AS), Preliminary, December 1986

RESPONSE AND COMMENTS FOR NASA QUESTIONS ON JEM POWER SYSTEM, June 10, 1986, NASA of Japan

SINEWAVE SYNTHESIS FOR HIGH EFFICIENCY DC-AC CONVERSION - Hans K. Asper, IECEC 1985, Paper No. 859178

SPACE STATION 20-KHZ POWER MANAGEMENT AND DISTRIBUTION SYSTEM, I. Hansen, G. Sundberg, NASA Technical Memorandum 87314, June 23, 1986

SPACE STATION ELECTRIC POWER SYSTEM REQUIREMENT AND DESIGN, F. TEREN, IECEC 1987, Report No. 879003

SPACE STATION ELECTRICAL POWER DISTRIBUTION SYSTEM DEVELOPMENT - W. E. Murray, IECEC 1985, Paper No. 859216

STS/DBS POWER SUBSYSTEM END-TO-END STABILITY MARGIN, R. Devaux, et al., IECEC 1986, Paper No. 869398

20 KILOHERTZ SPACE STATION POWER SYSTEM, I.G. Hansen, F.J. Wolff, NASA, September 8, 1986, NASA Technical Memorandum 88801

270 VDC VARIABLE SPEED GENERATOR AND CONTROL UNIT, AIRCRAFT ELECTRIC POWER SYSTEM, Airesearch Mfg. Co., Naval Air Development Center, Technical Report (NADC-80014-60) May 1, 1980

APPENDIX A

ORGANIZATIONS INVOLVED IN HVdc COMPONENTS/SYSTEMS

Remote Bus Interrupters (RBI)

Teledyne Kinetics Division
410 South Cedrus Ave.
P.O. Box 427
Solano Beach, CA 92075

Westinghouse Electric Corp.
Electrical Systems Division
P.O. Box 989
Lima, OH 45802

Lockheed Advanced Marine Systems
3929 Calle Fortunada
San Diego, CA 92123

Eaton Corp., Cutler Hammer Division
Hartman Electric Co.
Milwaukee Center
Milwaukee, WI 53216

Flat Cable

W. L. Gore Associates Inc.
4747 East Beautiful Lane
P.O. Box 50699
Phoenix, AZ 85076-0699

Flat Cable Connectors

W.L. Gore Associates Inc.
4747 East Beautiful Lane
P.O. Box 50699
Phoenix, AZ 85076-0699

G & H Technology
1647 17th St.
Santa Monica, CA 90404-3893

dc/dc Converters

Inland Motors
4020 E. Inland Rd.
Sierra Vista, AZ 95635

TESLaco Inc.
490 S. Rosemead #6
Pasadena, CA 91107

Space Power Inc.
621 River Oaks Parkway
San Jose, CA 95134

Boeing Electronics Co.
Power Electronics and Product
Development
P.O. Box 24969, MS-9J-12
Seattle, WA 98124-6269

Contactors

Hartman Electric Co.
175 N. Diamont
Mansfield, OH 44902

Eaton Corp., Cutler Hammer Division
Milwaukee Center
Milwaukee, WI 53216

dc Bus Regulator

Space Power Inc.
621 River Oaks Parkway
San Jose, CA 95134

Aeroenvironment Inc.
825 South Myrtle Ave.
Monrovia, CA

Remote Power Controllers (RPC)

Kilovac Corp.
P.O. Box 4422
Santa Barbara, CA 93140

Teledyne Solid State
12424 Daphne
Hawthorne, CA 90252

Westinghouse Electric Corp.
Electrical Systems Division
P.O. Box 989
Lima, OH 45802

Rockwell International-Autonetics
Strategic System Division
P.O. Box 4192
3370 Mira Loma Ave.
Anaheim, CA 92803

Leach Relay Corp.
Power Management Group
6900 Orangethorpe Ave.
Buena Park, CA 90620

Motor Controllers

Aeroenvironment Inc.
825 South Myrtle
Monrovia, CA

General Electric Co.
Aircraft Control Systems Department
P.O. Box 5000
Binghamton, NY 13902

Jet Propulsion Laboratory
4800 Oak Grove Drive
Pasadena, CA 91109

Current Sensors

Liaisons Electroniques
Mechaniques SA Geneve
Lem SA 140, Chemin du-Centenaire
CH-1228 Plan-Les-OUATES/Geneva,
Switzerland

Micro Switch
11 West Spring Street
Freeport, IL 61022

Jet Propulsion Laboratory
4800 Oak Grove Drive
Pasadena, CA 91109

Systems Organizations

AF Wright Aeronautical Laboratory
Dept. of the Air Force
Wright-Patterson AFB, OH
45433 AFWAL/000C-1

NASA Lewis Research Center
Cleveland, OH 44135

NASA Goddard Flight Center
Greenbelt, MD

McDonnell Douglas Corporation
McDonnell Douglas Astronautics Co.
St. Louis Division
P.O. Box 576
St. Louis, MO 63166

McDonnell Douglas Corp.
Douglas Aircraft Corp.
Long Beach, CA

General Dynamics
Land Systems Division
1902 Northwood
Troy, NM 48084

Rockwell International Corp.
RocketDyne Division
6633 Canoga Avenue
Canoga Park, CA 91303

Boeing Co.
Boeing Commercial Airplane Co.
Seattle, WA

Boeing Co.
Boeing Military Airplane Co.
Seattle, WA

Boeing Co.
Boeing Aerospace Co.
Seattle, WA

Lockheed Corp.
Burbank, CA

Newport News Ship Building Co.
4101 Washington Avenue
Newport News, VA 23607

Department of Navy (NAVSEA)
Electrical Section
Washington, D.C. 20362-5101

RCA Astro-Electronics
Princeton, NJ 08540

Naval Air Development Center
Warminster, PA 18974

SAE, Society for Automotive Engineers
The Engineering Society for
Advancing Mobility, Land, Sea, Air
and Space
400 Commonwealth Drive
Warrendale, PA 15096-0001

APPENDIX B

POWER CONTROLLER EFFICIENCY DATA COMPARISON

The data presented on developed power conditioners and dc bus regulators (Sections 5.3 and 5.4) have indicated a high level of achieved efficiency. The European Space Agency (ESA) has also independently performed analysis to determine power conditioner and dc bus regulator efficiencies. This analysis was performed by ESA, for the ESA module or space station. A comparison of these efficiencies is shown in Table B-1.

The efficiencies tabulated from this report confirm the efficiencies tabulated from the ESA study [1-3]. On this basis the data presented above is a realistic representation of what can be expected from available hardware.

Table B-1. Power Controller Efficiency Data Comparison

Function	Efficiency Results of this Report	Efficiency ESA Study [1-3]
dc/dc bus regulator (battery charger, bus regulator, heater and resistor load control)	98.5% Table 5-6	97.3%
dc/dc converter with isolation 150 Vdc output	95% Table 5-5	95.5%
dc/dc converter with isolation	85% at 5 Vdc output up to 90% at 15 V-24 Vdc Appendix C	89% at 28 Vdc



APPENDIX C

STATE-OF-THE-ART TECHNOLOGY IN dc-TO-dc CONVERTERS

SLOBODAN ĆUK
POWER ELECTRONICS GROUP
CALIFORNIA INSTITUTE OF TECHNOLOGY
JUNE 17, 1988

ABSTRACT

A critical review is made of the state-of-the-art switching power supplies operating from the 120 V to 160 Vdc bus. A special emphasis is placed on the high power density and high efficiency, light weight performance parameters for the power supplies in the broad power range from 25 W to 3 kW, in a single output, as well as multiple-output configurations. The cost of the high power density converters is also discussed.

INTRODUCTION

It is clear that by increasing the switching frequency the size and mass of magnetic and capacitive components are reduced, leading to light weight and compact converters. This has led to the switching frequencies being reported in the 10 MHz range, and as high as 24 MHz for a 50 W resonant power supply. However, this unchecked increase in switching speed has a very undesirable side effect: the reduction of the overall conversion efficiency. This is not only the result of the increased switching losses, but also the increase of the magnetic core losses, as well as copper losses due to skin effect. Therefore, at about 1 MHz switching frequency level, the point of diminishing returns is reached, where further increase leads only to a small decrease of the overall size, due to primarily magnetic circuit limitations. This, however, leaves wide open the region of 100 kHz to 1 MHz in which the light weight, high power density, high efficiency converters can be made, using the readily available ferrite magnetic core, and standard semiconductor and chip capacitor components, and employing the proven PWM (Pulse Width Modulated) techniques. The overall power conditioner topology of the CUK converter is shown in Figure C-1 for a 100 W unit with a 270 Vdc input and a 5 Vdc output.

POWER VERSUS OPERATING FREQUENCY AND FIGURE OF MERIT

The design difficulty in PWM converters can be directly related to how much current is switched at what switching rate, which ultimately leads to speed power product. Based on that, one may develop a rough figure of merit (FM) of design difficulty as per Table C-1.

Table C-1. FM = Power Switching Speed = 50×10^6 W/s

25 W	50 W	100 W	200 W	400 W	1 kW	2 kW
2 MHz	1 MHz	500 kHz	250 kHz	125 kHz	50 kHz	25 kHz

This simply outlines that it is roughly as equally challenging to design a 50 W converter at a 1 MHz switching rate as it is to design a 20 W at a 250 kHz rate, or a 1 kW at a 50 kHz rate. This measure is, of course, only to provide the first rough measure of design complexity and is in no way representative of the state-of-the-art limits. For example, several years ago TESLaco designed a 2 kW, 100 kHz feasibility prototype for the Space Shuttle which was successfully demonstrated. With the better semiconductor switching devices presently available, as well as better magnetic and capacitive components, this design could be even further reduced in weight (from original 8 lb) by pushing the switching frequency into the 200 kHz or even the 300 kHz region.

This review has utilized several papers describing 50 W and 100 W dc-to-dc PWM converters operating at 500 kHz, 50 W resonant switch converters operating at 800 kHz, and 2 kW converter operating at 100 kHz [C-1, C-2].

They all point out that with the presently available components, ultra light and high-power density high efficiency converters can be made. Each of the specific performance characteristics is addressed separately.

POWER DENSITY

Most recently, the state-of-the-art power density of 50 W/in³ has been reported for the converters in the 50 W to 100 W power range. However, this does not assume the availability of the cold plate or some other efficient means of the heat removal, such as fan cooled, since the above figure does not include the heat sink. However, with the heat sink included, the power density of 20 W to 30 W/in³ is possible with present-day component technology.

At the higher power levels of 500 W to 2 kW, the power density has to be reduced due to the increased total power dissipation, and the derating of components to a range of 5 W/in³.

EFFICIENCY

In the 50 W to 200 W range and operating at 500 kHz, the efficiency of 80 percent was attainable for a 5 V, 20 A dc/dc converter, for example. However, if the extremely small size of this unit achieving the ultra high power density of 25 W/in³ is traded for increase in efficiency, primarily through the use of the bigger, more efficient cores and reduced switching frequency to 200 kHz or lower, the efficiency in excess of 85 percent can be obtained, for the 5 V output loads. For higher output voltages, such as 15 V or 24 V outputs, efficiency approaching the 90 percent could be obtained. This is primarily because the losses are still dominated by the output rectifier dc or steady-state losses. For example, in a 5 V output with a 0.5 V forward voltage drop on the Schottkey diode, efficiency is reduced by 10 percent due to these losses alone. The combined magnetic losses typically amount to the range of 1 percent to 2 percent. For example, for a 50 W converter, 0.8 W total magnetic circuit loss (including transformer and all filtering inductors) is typical. Similarly, the typical switching transistor losses of 2 W and conduction losses of 1 W further reduce the overall efficiency.

MAGNETIC COMPONENTS

Presently, the only useable magnetic material at frequencies above 100 kHz is ferrite. Although saturation flux density of the ferrite material is in the range of 0.4 tesla to 0.5 tesla, the flux density at 500 kHz, for example, has to be typically derated to the level of 50 mT to 100 mT because of the excessive core losses. The derating is accomplished by use of the larger size cores. Even with the use of some sophisticated magnetics circuits, such as Coupled-Inductor and Integrated Magnetics Circuits [C-3, 4-4], the size and weight of the magnetic circuits still dominate the overall converter size and weight, and are typically several times that of the converter capacitive content.

CAPACITORS

The switching frequency increase beyond 100 kHz permits, for the first time, the replacement and elimination of the unreliable electrolytic capacitors by the film capacitors, which offer practically unlimited lifetime. They do not suffer from the electrolytic gradual evaporation, over time, and the eventual loss of capacitance. The chip capacitor advances made in the last several years are particularly dramatic. Not only is the packaging density increased by an order of magnitude by use of material with increased dielectric constants, packaging some 100 microfarad into a capacitor occupying only a 1 cm² surface and 2 mm high, but they are now offering much higher rms ripple current capability and lower ESR. Only several years ago, 1 A to 2 A capacitor ripple current ratings were available in 3.3 microfarad chip capacitor, which has by now been raised to 11 A ripple current ratings and 2 to 3 milliohm ESR at 200 kHz. Consequently with a single capacitor such as this operating at 200 kHz rates, the output load currents of up to 30 A into 5 V load, or 150 W power levels are made possible [C-4]. This clearly points out that the magnetics components due to the high core material losses are by far the most important factors limiting the size and weight of switching converters.

FREQUENCY RESPONSE

With the advent of the current mode programming control method, the converter loop-gain response may be shaped to look like an ideal single-pole response all the way up to a decade below the switching frequency. Consequently, the loop-gain can be closed in that region, to result in a closed-loop bandwidth approaching one tenth of the switching frequency. For example, the 100 W converter operating at 500 kHz may be designed to give a 20 kHz bandwidth with an excellent 70 degree phase margin (see reference 4-4 for a practical design example). The corresponding transient response is equally excellent, leading to a less than 1 percent peak voltage overshoot for a half load to full load step current change. The corresponding settling time of 100 μ s agrees less well with the 20 kHz bandwidth. For the switching converters operating at 100 kHz, for example, this results in the reasonable bandwidth of 5 kHz to 10 kHz, which is still excellent for even the most demanding applications.

EMI CONSIDERATION AND CONTROL

At the increased switching frequencies of 100 kHz to 500 kHz, even the EMI filters needed for the reduction of both common mode noise and differential mode noise are occupying much smaller size and are much lighter. For example, for a 100 W converter, a single section common-mode choke designed on a toroid with a 0.5 cm diameter and 3 mm height is typically sufficient to suppress the noise switching MIL-STD 461 B. These noise reduction filters are also accompanied by other noise reduction measures, such as Faraday shields in the transformers, which alone can reduce EMI noise by a factor of 10 to 20. Other techniques, such as splitting input filtering inductor optimally between the top and return leg, might lead to an additional order of magnitude of noise reduction (factor of 10 to 30) [C-2].

MULTIPLE OUTPUT SWITCHING POWER SUPPLIES

At only a slight increase of the overall space, it is now possible to take advantage of high frequency switching to make small size and weight multiple output switching power supplies. For example, TESLaco has just completed a 100 W four output switching power supply which is packaged in a 3.2 in. x 3.5 in. x 0.65 in. hybrid package. This package includes not only all EMI filtering needed to meet military specification requirements, but additional signal processing requirements, such as remote sense and other capabilities. This design also operates at 500 kHz, which appears to be the best frequency range for the presently available components. This design should be compared with a much simpler, single output 100 W design which takes 2 in. x 3 in. x 0.5 in. and does not include EMI filter and extra signal processing circuitry. With those included, its size would probably grow 3 in. x 3 in. x 0.5 in. Hence the penalty paid in going to multiple outputs is only about a 25 percent increase in space requirements. It should also be mentioned that besides the main output, which is fully regulated, other outputs can be cross-regulated to within ± 5 percent of its nominal value for the worst case changes in the line voltage or load current [C-5].

WIDE DYNAMIC RANGE

The dc-to-dc converters operating over the wide dynamic range of 3:1 and even 4:1 input voltage variation are now becoming a practical possibility. For example, the most recent TESLaco design operates from a 13 V to 52 Vdc input, an effective 4:1 input voltage range. In addition it is capable of withstanding the input voltage transient of up to 75 V. Similarly the designs which once required a front end rectifier reconfiguration to change over from 110 Vac to 220 Vac operation can now be made to cover the full voltage range from 90 Vdc to 360 Vdc without requiring any front end changes.

OUTPUT VOLTAGE RIPPLE PERFORMANCE

While typical commercial power supplies require 1 percent relative ripple voltage, such as for example, 50 mV ripple voltage for a 5 V output, much better ripple performance can be made if the specifications so require. For example in a 2 kW, 100 kHz design for Space Shuttle, TESLaco obtained a very low 10 mV peak to peak ripple for a 30 V output, hence an effective 0.03 percent relative ripple. Therefore, a very clean output as well as input can be made with present day technologies.

POWER SUPPLY WEIGHT

The range of power supply weight can be best appreciated using the two extreme examples. On one hand, the recent 50 W, 500 kHz design weighs 50 grams, leading to an effective per weight power density of 1 W per gram. On the other side, the 2 kW, 100 kHz design [C-1] weighs 7 kg and results in an effective 0.3W/gram power density. Since this design is now several years old, with present day technology it could be pushed to 0.5 W/gram. Similarly, the 50 W design, when additional heat sink is provided, would come down to a 0.5 W/gram power density.

CONCLUSION

This review of the state-of-the-art technology in the switching dc-to-dc converters clearly brought out that very high power density converters approaching 50 W/in^3 , operating at high efficiency of 85 percent, and resulting in a light weight approaching 1 W/gram can be made with the present day component technologies. In addition, increased switching frequency rates in the range of 100 kHz to 500 kHz for power range from 2 kW to 20 W lead to a side benefit of considerably improving the bandwidth to a 20 kHz as well as step-load transient response settling time to less than 100 ms.

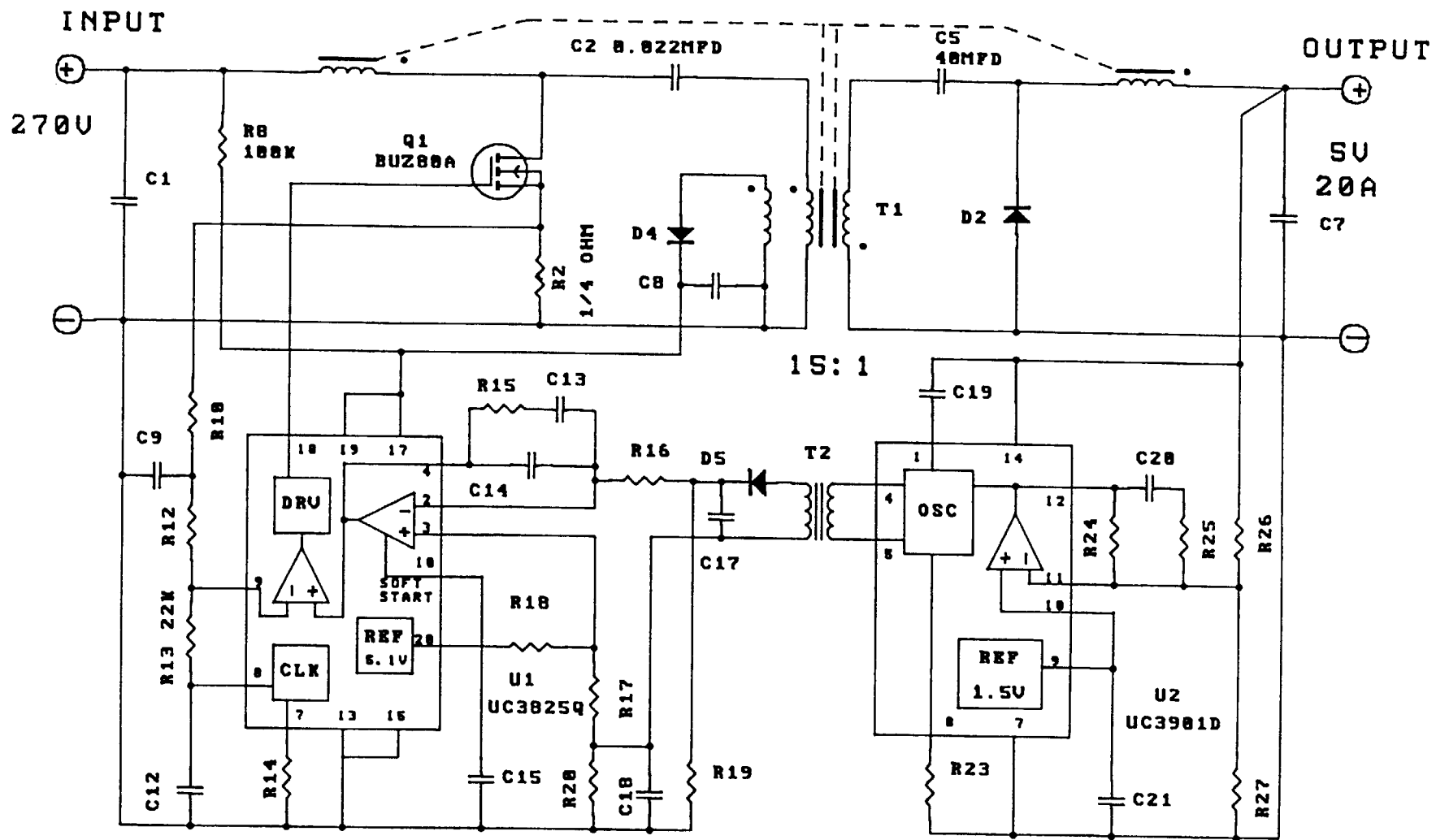

Figure C-1. Power Conditioner 270 Vdc Input, 5 Vdc Output, 100 W

1. Report No. 88-26	2. Government Accession No.	3. Recipient's Catalog No.	
4. Title and Subtitle The State of the Art of dc Power Distribution Systems/Components for Space Application		5. Report Date July 1988	
		6. Performing Organization Code	
7. Author(s) S. Krauthamer		8. Performing Organization Report No.	
9. Performing Organization Name and Address JET PROPULSION LABORATORY California Institute of Technology 4800 Oak Grove Drive Pasadena, California 91109		10. Work Unit No.	
		11. Contract or Grant No. NAS7-918	
		13. Type of Report and Period Covered JPL Publication External Report	
12. Sponsoring Agency Name and Address NATIONAL AERONAUTICS AND SPACE ADMINISTRATION Washington, D.C. 20546		14. Sponsoring Agency Code Re241 BH-476-30-40-11-00	
15. Supplementary Notes			
16. Abstract <p>This report is a survey of the state of the art of high voltage dc systems and components. This information can be used for consideration of an alternative secondary distribution (120 Vdc) system for the Space Station. All HVdc components have been prototyped or developed for terrestrial, aircraft, and space applications, and are applicable for space applications with appropriate modification and qualification. HVdc systems offer a safe, reliable, low mass, high efficiency and low EMI alternative for Space Station secondary distribution.</p>			
17. Key Words (Selected by Author(s)) Spacecraft Propulsion and Power; Subsystems; Conversion Techniques.		18. Distribution Statement Unclassified/Unlimited	
19. Security Classif. (of this report) Unclassified	20. Security Classif. (of this page) Unclassified	21. No. of Pages 89	22. Price

HOW TO FILL OUT THE TECHNICAL REPORT STANDARD TITLE PAGE

Make items 1, 4, 5, 9, 12, and 13 agree with the corresponding information on the report cover. Use all capital letters for title (item 4). Leave items 2, 6, and 14 blank. Complete the remaining items as follows:

3. Recipient's Catalog No. Reserved for use by report recipients.
7. Author(s). Include corresponding information from the report cover. In addition, list the affiliation of an author if it differs from that of the performing organization.
8. Performing Organization Report No. Insert if performing organization wishes to assign this number.
10. Work Unit No. Use the agency-wide code (for example, 923-50-10-06-72), which uniquely identifies the work unit under which the work was authorized. Non-NASA performing organizations will leave this blank.
11. Insert the number of the contract or grant under which the report was prepared.
15. Supplementary Notes. Enter information not included elsewhere but useful, such as: Prepared in cooperation with... Translation of (or by)... Presented at conference of... To be published in...
16. Abstract. Include a brief (not to exceed 200 words) factual summary of the most significant information contained in the report. If possible, the abstract of a classified report should be unclassified. If the report contains a significant bibliography or literature survey, mention it here.
17. Key Words. Insert terms or short phrases selected by the author that identify the principal subjects covered in the report, and that are sufficiently specific and precise to be used for cataloging.
18. Distribution Statement. Enter one of the authorized statements used to denote releasability to the public or a limitation on dissemination for reasons other than security of defense information. Authorized statements are "Unclassified-Unlimited," "U. S. Government and Contractors only," "U. S. Government Agencies only," and "NASA and NASA Contractors only."
19. Security Classification (of report). NOTE: Reports carrying a security classification will require additional markings giving security and downgrading information as specified by the Security Requirements Checklist and the DoD Industrial Security Manual (DoD 5220.22-M).
20. Security Classification (of this page). NOTE: Because this page may be used in preparing announcements, bibliographies, and data banks, it should be unclassified if possible. If a classification is required, indicate separately the classification of the title and the abstract by following these items with either "(U)" for unclassified, or "(C)" or "(S)" as applicable for classified items.
21. No. of Pages. Insert the number of pages.
22. Price. Insert the price set by the Clearinghouse for Federal Scientific and Technical Information or the Government Printing Office, if known.



