

NASA Technical Memorandum

NASA TM- 100338

AN APPLICATION OF "HIGH AUTHORITY/LOW
AUTHORITY CONTROL" AND "POSITIVITY"

By S. M. Seltzer, D. Irwin, D. Tollison,
and H. B. Waites

Structures and Dynamics Laboratory
Science and Engineering Directorate

August 1988

(NASA-TM-100338) AN APPLICATION OF HIGH
AUTHORITY/LOW AUTHORITY CONTROL AND
POSITIVITY (NASA) 15 P CSCL 22B

N89-11791

63/18 Unclass
0169013



National Aeronautics and
Space Administration

George C. Marshall Space Flight Center



TABLE OF CONTENTS

	Page
INTRODUCTION	1
APPLICATION OF HAC/LAC TO ACES	2
APPLICATION OF "POSITIVITY" TO ACES.....	5
HAC/LAC OBSERVATIONS	6
POSITIVITY OBSERVATIONS	7
CONCLUSIONS	8
SUMMARY	9
REFERENCES	10

PRECEDING PAGE BLANK NOT FILMED

LIST OF ILLUSTRATIONS

Figure	Title	Page
1.	Closed-loop HAC system with set point inputs	3
2.	Positivity controller configuration	5

TECHNICAL MEMORANDUM

AN APPLICATION OF "HIGH AUTHORITY/LOW AUTHORITY CONTROL" AND "POSITIVITY"

INTRODUCTION

High Authority Control/Low Authority Control (HAC/LAC) is the Large Space Structure (LSS) control system design technique developed by Lockheed Missiles and Space Corporation under the Active Control of Space Structure (ACOSS) Program. References 1 and 2 were used as the beginning documentation for Control Dynamics' study of the HAC/LAC technique. HAC/LAC has as its cornerstone the separation of the control system design problem into two parts. The first, HAC, is a high-gain, low-bandwidth controller including high authority actuators. The second part is LAC which is a low-gain, broad-bandwidth control law. This separation of the control problem gives the designer a way in which to interject understanding and intuition into the control system design process. The greatest disadvantages to this approach are the stability and robustness problems associated with a two-part design procedure.

Actual design of the HAC control law is accomplished using Linear Quadratic Gaussian (LQG) techniques on a reduced order model. Selection of that model is an important part of the HAC design. The HAC model must include the system modes essential to performance as well as any modes which participate greatly in the actuator-to-sensor transfer function and therefore have a great effect on system stability. The selection of the model has an obvious impact on the success of the control system design. The HAC controller will have the same order as the HAC model. Many model reduction schemes give no guarantee of system stability when the controller is used in conjunction with plant models other than the one for which it was designed, i.e., there are no guarantees of robustness.

The LAC controller design is intended to stabilize a system which has been destabilized by the effects of spillover from modes not included in the HAC design model by augmenting the system damping (i.e., damping the structural modes). The LAC controller has no dynamical order; it is an output feedback gain matrix whose size is the number of actuators by the number of sensors. Because the LAC process is designed for continuous systems only, allowance must be made for the effects of implementing it digitally.

"Positivity," strictly speaking, is a system property. However, it has been applied in ACOSS-14 [3] as a design approach advocating the use of positivity concepts to design controllers for systems with extremely "rough" models. The approach advocates the use of other multivariable frequency domain methods as more information is gathered concerning the system model, so that system performance objectives can eventually be achieved. If, for example, the controller $H(s)$ and the plant $G(s)$ are in cascade, the Positivity Theorem states that the resulting feedback system is Bounded-input/Bounded-output (BIBO) stable if both H and G are "positive" and at least one of them is "strictly positive." The technique can be applied to non-positive systems by utilizing operator imbedding to impose design constraints. The original motivation for considering the use of positivity concepts for LSS controller design was the fact that an LSS with collocated ideal actuators and ideal rate sensors is, in fact, a positive system. Unfortunately, in the presence of actuator or sensor dynamics an LSS is no longer positive, even if the sensors and actuators are

collocated. In addition, if the overall system is sampled-data in nature, there is no guarantee that the system will be positive.

Characteristic loci methods do not necessarily suffer from the aforementioned limitation and are intended to aid in resolving the performance problems encountered when applying pure positivity. In the ACOSS reports, the suggestion is made to use characteristic loci to obtain performance and to use the positivity constraints to achieve robustness. The characteristic loci methods are based on a dyadic expansion of the frequency dependent transfer function matrix.

APPLICATION OF HAC/LAC TO ACES

The Active Control Technique Evaluation for Spacecraft (ACES) [4] problem has two aspects: performance, as embodied in the Image Motion Compensation (IMC) system, and structural damping, which is considered essential for control of lightly damped space structures, even though it may not be required for performance directly. Such a case is that of an LSS which must undergo docking with another spacecraft and, therefore, should have some minimum structural damping so that the amount of energy stored in the structure is maintained below a specified level.

The two-part requirement for ACES matches well with the two-step control system design of HAC/LAC. The ACES design applied HAC to the IMC system to meet the performance requirements and then applied LAC to augment the structural damping. This facilitates the use of a very low (6th) order model for the HAC design and, therefore, a low order HAC controller. The model is comprised of three structural modes; however, they are not the three modes of lowest frequency in the structure. This is a departure from the normal use of lower frequency modes in the HAC model and higher frequency modes in the LAC model. It does not, however, violate the premise that the HAC model will be better known than the LAC model.

Control system design actually begins with what is called the baseline model. This is the dynamic model generated through Finite Element Model (FEM) techniques and refined with test data. The model, as received by the controls engineer, includes 43 modes and input/output gains for all actuator/sensor locations. The set of actuators and sensors and their locations are taken as fixed because of the impracticality of moving them around in the test facility. This is not so different from the constraints that are likely to be placed on a real spacecraft design where issues other than control are likely to have a great impact on hardware design. The LAC design then uses a collocated set of sensors and actuators to effect the required structural damping.

The HAC design for ACES was performed in the digital domain. Because it must be capable of rejecting the DC disturbance due to rigid body translation of the entire structure at the Base Excitation Table (BET), each channel contains one free integrator. The HAC design model then includes a discretized sixth order HAC design model, two pure delays to represent the computational delay, and two first order integrators (trapezoidal). The resulting system has two inputs (IMC gimbal torques) and four outputs [Line-of-Sight (LOS) errors and their integrals]. The adjustable design parameters for the HAC feedback control gain design include a 10×10 state weighting matrix (Q) and a 2×2 control input weighting matrix (R).

The closed-loop HAC system with set point inputs is shown in Figure 1. The adjustable design parameters for the Kalman Filter* design include a 10 x 10 state weighting matrix (G) and a 4 x 4 output weighting matrix (H). In each design iteration, Q is chosen to penalize the LOS error, and the penalty is then distributed to the states for use in the design. The optimal feedback gain matrix is then computed, followed by the computation of the Kalman filter gain matrix. The resulting system response is then computed and assessed before another design iteration is tried, if deemed necessary.

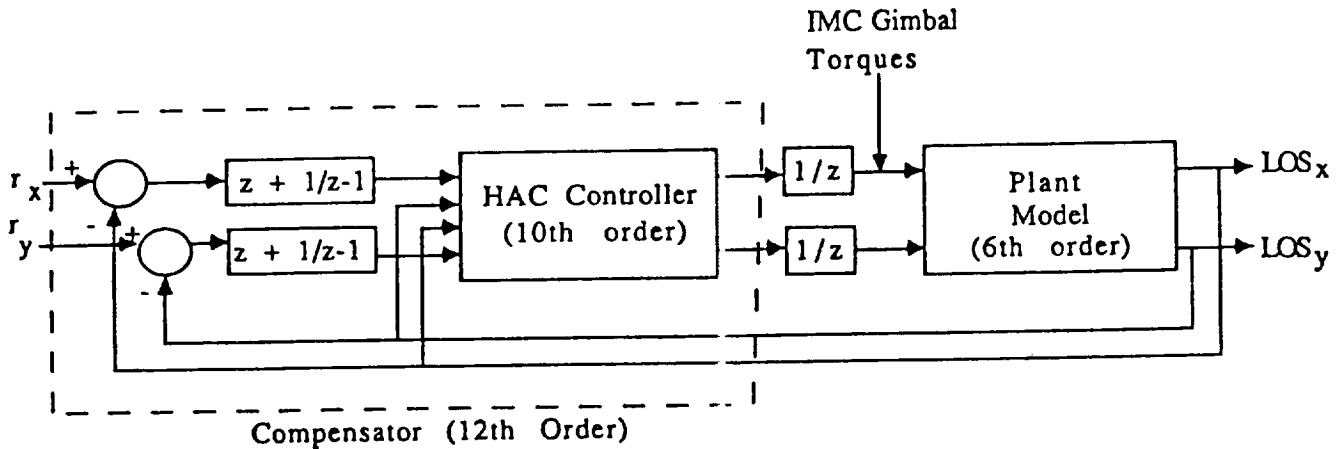

Figure 1. Closed-loop HAC system with set point inputs.

A collocated, consistent set of sensors and actuators is required if LAC is to exhibit its fullest robustness properties. In addition, the sensors must measure rates. The only sensor/actuator pairs in the ACES configuration which strictly meet the requirements are the Advanced Gimbal System (AGS) gimbals and faceplate rate gyros. This set is almost exactly collocated because of the rigid nature of the AGS faceplate and gimbal hardware, and the fact that the axes of the gimbals and rate gyros are accurately aligned. In addition, the AGS torquers are wide bandwidth and respond all the way to DC on the low frequency end of the spectrum. The same is true for the rate gyros. An added attraction of the gimbal location is that most of the structural vibration can be sensed at this location. The only other collocated consistent sensor/actuator pairs are the Linear Momentum Exchange Devices (LMEDs) and their collocated accelerometers. However, use of the LMEDs with the LAC design technique presents several unique problems beyond the scope of this paper. A small but obvious consideration is that a rate measurement is required. It is reasonable to assume that the accelerometer outputs could be integrated to obtain translational rate measurements, so this presents little difficulty. Of much greater import is the non-collocated characteristic of the LMED sensor/actuator pair. This phenomenon is not because of physical noncollocation but rather because the LMED is not a force actuator at low frequencies.

The LAC design process consists of computing the feedback gain matrix using the LAC plant. The continuous closed-loop system is formed using the gain matrix and the LAC plant, and the poles are examined. This is repeated using the full-order plant. Then the digital closed-loop system with delays is formed, using the gain matrix and the full-order plant, and the poles are again examined. When the LAC design plant was closed it was found that the system exhibited less than the damping specified in the design, but it was adequate to form a solidly stable system.

* We use the term Kalman Filter loosely; here no attempt is made to model any particular system disturbances in the design of the "optimal" estimator (Kalman Filter).

After fully checking LAC performance, the combined HAC/LAC controller was subjected to four disturbances, termed Crew Motion, Reaction Control System (RCS), Riverside, and MSFC Demonstration. The Crew Motion disturbances represented measured crew disturbances gathered during actual Skylab flights. The RCS disturbance represents flight data that has been scaled for the LSS test. The Riverside disturbances were developed analytically during the ACOSS program to represent SDI-type on-board Space Based Laser disturbances, such as rotating machinery and large flow rates of coolant impacting on-board optics. Finally, the MSFC Demonstration disturbances were developed to indicate the amount of vibration suppression on the LSS beam. The results illustrate that significant performance gains are precluded by the presence of unmodeled dominant LOS behavior and by the very low level disturbances required to maintain the photodetector operation in a linear range. This latter constraint leads to periods of open-loop Astromast control, since the angular rates at the faceplate are used to achieve all of the stabilization of the Astromast structure. The unmodeled LOS behavior refers to a 0.2-Hz oscillatory mode of vibration observed at the detector. Since this mode lies within the bandwidth of the IMC system and the Astromast system, it probably is a "localized mode" at the antenna/detector mount assembly. This is consistent with the fact that the antenna behavior in the model is the most suspect. Both the Crew and the RCS disturbance cases showed that the 0.6-Hz "pendulum behavior," for example, was damped effectively, while there was little improvement in the 0.2-Hz behavior. Little improvement in the closed-loop results occurred when the Riverside disturbance was applied. The reason for this lack of improvement lies in the nature of the disturbance, which is persistent and has two relatively pure sinusoidal components. Effective rejection of the pure components would require an unreasonably high bandwidth IMC controller, given the limitations imposed by the 50Hz sampling frequency.

The results of the MSFC Demonstration disturbance are given in the form of faceplate angular rates. When open-loop and closed-loop cases are compared, a significant degree of damping is achieved with the controller. This disturbance illustrates the performance gains that are possible with significant signal levels at the faceplate.

Summarizing the experimental test results for the HAC/LAC controller, mean and root-mean-square (RMS) detector errors for open and closed-loop tests were averaged over five tests each. The requirement to remain in the linear region of operation was satisfied for the Crew, RCS, and Riverside disturbances. The results showed that the HAC/LAC controller improved the detector mean in the X and Y axes but did nothing to improve the RMS detector errors (X and Y). The lack of RMS improvement for the Crew and RCS disturbances is explained by the unmodeled 0.2-Hz mode which dominated the behavior of the detector response. If the 0.2-Hz mode was modeled, the controller would likely have added considerable damping to the mode. The lack of RMS improvement for the Riverside disturbance is not unexpected since the IMC bandwidth is less than 2 Hz. The Demonstration disturbance was utilized for the purpose of indicating the amount of vibration suppression of the beam provided by the HAC/LAC controller. The results of the Demonstration disturbance did not meet the requirement to remain in the linear range. The detector error is not a very meaningful value for the Demonstration disturbance; hence, the more meaningful variables of faceplate gyro settling time and detector percentage hits were used. The test results indicate that the settling time is improved by 11 sec in the X axis and by 32 sec in the Y axis, and the percentage of hits was increased from 51 percent to 67 percent.

APPLICATION OF "POSITIVITY" TO ACES

The Positivity design is begun by choosing a reduced-order modal model from the set of 43 modes of the dynamic model. However, in contrast to the motivations for model reduction for HAC/LAC, the purpose of the model reduction process is not to ensure a lower order controller. Rather, the purpose is to minimize the computations required to generate the frequency response matrix needed in the Positivity design. Thirty-one of the available 43 modes were selected for the Positivity design model, based on the contributions of each mode to the elements of the transfer function matrix. The evaluation criterion dictated that a mode be retained in the design model if its contribution to any of the elements of the transfer function matrix exceeded 6 decibels at any frequency up to half of the sampling frequency. In addition, all of the sensors and actuators are included in the model. Where available, pertinent sensor and actuator dynamics are included in the transfer function matrix model. Finally, the sampled-data version of the transfer function matrix is computed via a truncated series technique. The feedback configuration that was originally assumed for the design process is shown in Figure 2. A simplified constant square down matrix was chosen so that modes which are more significant at the LOS are emphasized in the new (artificial) outputs.

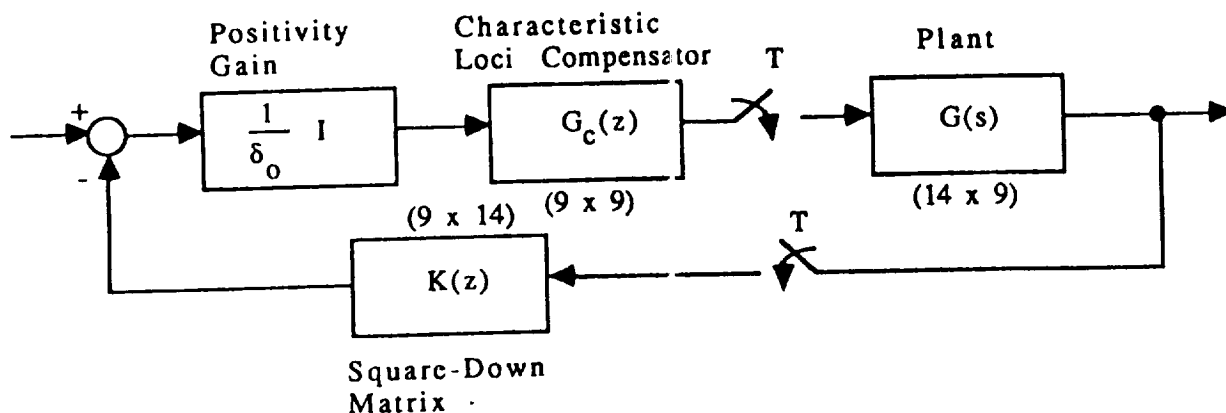

Figure 2. Positivity controller configuration.

The LMED accelerometer outputs were compensated in order to increase their collocation properties. Phase stabilization of the LMED outputs was used to provide the possibility of damping at lower frequencies. Since the LMED pairs are now approximately collocated (using the compensated outputs), the partial square down matrix can be easily modified to preserve the collocation properties of these pairs. The resulting "squared down" system transfer function matrix exhibits excellent collocation properties itself, as the LMED "rates" and the AGS angular rates appear to contribute most heavily to the elements of the transformed outputs. Unfortunately, it was discovered that the LMED compensation was extremely sensitive to the actual modal data. Hence, the LMEDs were discarded as A/S pairs after testing began.

The next step in the design process (which is required for the characteristic loci methods) is the calculation of a dyadic expansion of the frequency response matrix. The resulting form of compensation, $K(s) = A \Gamma(s) B$, that was dictated required a "frame alignment" of matrices A and B that was insufficient to meet the

performance requirements. Hence the frame alignment process was abandoned. A controller is postulated where an identity matrix is multiplied by a scalar transfer function. The limitation, of course, is that the same compensation must work for all n of the characteristic loci for the controller to be significantly beneficial. In the case of the ACES configuration, the collocation properties of the squared down system permit the use of such a controller, since destabilization is not a serious problem. Actually, much more freedom is gained by virtue of the collocation properties, since any reasonable constant gain diagonal controller can simultaneously provide stability and modal damping. The final controller is designed in such a way, with single lead stages inserted in five of the seven forward paths, to allow damping at higher frequencies than would normally be possible for a sampled-data system. Since the lead stages actually upset the collocation properties, the Generalized Nyquist criterion was used to verify the stability of the resulting closed-loop system. The five lead stages, together with the LMED compensation and the accelerometer integrators, yield a controller for the Astromast subsystem which is 19th order.

An interesting phenomenon is apparent in the frequency responses of the IMC. Due to the degree of modal damping attained with the Astromast components, the IMC frequency responses exhibit only the pendulum behavior associated with the two gimbals. The two dominant channels of the IMC subsystem are compensated separately, the only compensation required being integrators for forcing a Type 1 system and lead devices for management of the crossover frequencies. The bandwidths of the resulting systems are both roughly 2.0 Hz. The combined controller (IMC and Astromast) is 23rd order.

Results of a high fidelity simulation with an RCS input disturbance show that not only is a high degree of damping apparent, but the IMC system effectively rejects the very low frequency behavior due to the Astromast torsional mode and the AGS hinge point pendulum modes. The positivity design was then subjected to the four ACES disturbances.

Summarizing, results of the tests show that the Positivity controller improved the detector mean in the X and Y axes (i.e., it removed the DC bias), but it did almost nothing to improve the RMS detector errors (X and Y). The lack of RMS improvement for the Crew and RCS disturbances is explained by the unmodeled 0.2-Hz mode which dominated the detector response. If the 0.2-Hz mode had been modeled, the controller most likely would have added significant damping to the mode. The lack of RMS improvements for the Riverside disturbance is expected because the 8- and 10-Hz sinusoids are above the controller bandwidth. When the Demonstration disturbance was utilized, test results indicated that the settling time was improved by 20 sec in the X axis and by 47 sec in the Y axis, and the percentage of hits was increased from 66 percent to 89 percent.

HAC/LAC OBSERVATIONS

It should be noted that HAC/LAC is not a design algorithm. In other words, HAC/LAC applied by different designers to different problems may lead to very different problem approaches. Significant parts of the theory of HAC/LAC are contained in the literature and lore of LQG design. This background can be expected to exist in any organization undertaking the design of high performance control systems for large space structures. The major exception is the LAC portion of HAC/LAC, but it is relatively easy to understand and implement.

While the analytical design of the HAC/LAC controller can be termed a success, it must be noted that the performance of the controller in the hardware implementation is well below expectations. The major contributor to this is the effect of the unmodeled mode at 0.2-Hz which is probably due to behavior at the antenna base. However, other contributors to the performance problem include the nonlinearity of the photo-detector which causes extremely low signal levels at the AGS gyros and the noncollocated properties of the LMEDs.

Analytical problems also occurred which led to limitations on the achievable performance of the system, including the decision to omit the LMEDs from the LAC part of the design. Many of these problems are due to the fact that the LAC design process is limited to collocated sensor/actuator pairs and that, strictly speaking, HAC/LAC is most applicable to continuous-time systems. The collocation limitation leads immediately to the omission of LMEDs from the control design, and the continuous-time limitations lead to extreme conservatism in the LAC design. It should be noted that although the LMEDs could have been included in the HAC design, the expected sensitivity of the controlled led to the decision to omit them entirely.

A summary of the advantages of HAC/LAC would have to include the capability to perform a conservative part of the design with LAC and the ability to obtain high performance via LQG (HAC) techniques. The disadvantages of HAC/LAC include the limitation of LAC to collocated sensor/actuator pairs, the sensitivity and robustness problems associated with LQG designs, and the limitation of the LAC technique to continuous-time systems. HAC/LAC can be used to effect the design of a control system for a large space structure as long as the designer fully realizes the fact that HAC/LAC is not actually a formal design process, but a collection of tools which can be helpful in the design.

POSITIVITY OBSERVATIONS

Compared to the other techniques investigated in the ACES program, Positivity is the least familiar. However, its main component, the characteristic loci technique, is not difficult to comprehend once the parallels to classical scalar frequency domain techniques are outlined.

The results of the complete design of the controller using the Positivity and characteristic loci methods are not encouraging. While it is possible to design a controller using these techniques, the techniques are awkward to use and do not seem to be directly applicable to the complicated models encountered in the field of LSS control. These facts may be due to the sketchy documentation available on the actual use of the methods. While the theory of Positivity and its extensions give indications of the desirable frequency domain attributes of a particular system, there is almost no indication of how to achieve these goals. The exception is the characteristic loci method, which is an extension of classical frequency domain compensation techniques to the multivariable case. However, even with characteristic loci there are significant gaps between knowledge of the goals of the controller and their actual achievement. The weak link in the characteristic loci method appears to be the alignment procedure. Here again, the available documentation is sketchy. For example, no evaluation criteria of the success of the various alignment procedures can be found.

CONCLUSIONS

The goals of the ACES program were to design, test, and evaluate three controllers for the ACES configuration at the MSFC facility. Two of the controllers, HAC/LAC and Positivity, are discussed in this paper. The main evaluation criterion was the reduction of LOS error due to four specified disturbances. During the test cycle it became apparent that the performance benefits based on the LOS criterion alone were not sufficient to allow a definitive evaluation and comparison of the several controllers. As the program progressed, it became clear that the main benefit of the ACES program was its contribution to the maturity of LSS control system design in general and to the maturity of the design techniques in particular.

Software. Although there is a wealth of software available for effecting the calculations necessary for each of the design "algorithms," the time required to implement a software system for use in a design iteration process is significant. A well-tested, commercially available, and highly flexible control design software system is almost a necessity when undertaking controller designs using these techniques. Even with the availability of such a package, some code development is mandatory; such development can be done in the package's higher level language or in more primitive languages such as FORTRAN. Although each of the techniques requires some amount of software development, this task is not particularly difficult for any of the techniques when building from a good existing package. However, acquiring the capability to dependably effect these designs without such a package would be a formidable task.

Model Fidelity. Each of the techniques requires an excellent model in order to dependably obtain correspondingly excellent performance in hardware implementation. This statement is supported in full by the results of the hardware testing. The 0.2-Hz unmodeled mode almost completely invalidates the planned quantitative LOS evaluation criterion since (1) the LOS error is predominantly due to this mode and (2) none of the controllers significantly improved its behavior. Unmodeled low frequency modes are especially hazardous because they typically lie within the controller bandwidth and are thereby prime candidates for spillover destabilization.

Technique Applicability. Each of the techniques is capable of yielding controller designs for high order systems. HAC/LAC suffers from no outstanding limitations except that the LAC design requires collocation for at least some of the sensors and actuators. An undesirable situation may present itself if the spillover modes that LAC is intended to stabilize are not observable and/or controllable via the LAC hardware. This situation did not occur during the ACES program. Positivity is appropriate for certain high order systems but may not be suitable for lightly damped systems such as large space structures due to possible problems with frame alignment. However, the characteristic loci methods should not be discarded as a design option until, and unless, the alignment problems are investigated more systematically.

Design Process Complexity. With a suitable software system in place for each of these techniques, the design process is not unduly difficult or tedious. None of the techniques yields a satisfactory controller without a significant amount of iteration, as should be expected when working with very complex systems.

Hardware Limitations. The limited dynamic range of the photodetector is the most critical hardware issue in regard to the achievable performance of the control systems. In order for the photodetector operation to be kept within its linear range, disturbances must be so small that other instruments operate at or below their resolution threshold. The obvious solution to the detector problem is to use a photodetector with a much greater dynamic range.

The LMEDS are a problem for which no easy solution exists. The presence of gravity dictates the use of proof-mass centering springs, which in turn limit the low frequency characteristics of the LMEDs as force actuators. In the case of the ACES configuration, the springs probably cannot be softened without eliminating the centering action. This is in effect an "electrical" spring! The problems would still exist!

SUMMARY

Each of the design techniques can be used to design controllers for large space structures which prevent destabilization of unmodeled modes. However, the prevention of destabilization is much easier to achieve than the realization of high performance. This fact leads to the sensible conclusion that control designers faced with achieving stringent performance specifications must in turn be able to specify acceptable tolerances on model error or accept more realistic performance and/or be prepared to perform a real time system identification so that a design-to-performance can be effected.

Software is a non-trivial aspect as regards the amount of effort required to use these design techniques. Although the component parts of the software required to effect the actual detailed calculations may exist beforehand, the truly important aspect of the software question is the time required to gather these components into a flexible, integrated, and easily-used design system.

The applicability of HAC/LAC and Positivity to high-order control system design is unquestionable. However, the applicability of Positivity and characteristic loci to the more particular case of large space structure control is unresolved. It should be noted that this conclusion may be highly dependent on the particular algorithms and approaches used in applying characteristic loci to the ACES problem.

REFERENCES

1. ACOSS Five (Active Control of Space Structures) Phase 1A, Rome Air Development Center, Griffiss AFB, NY, Report No. RADC-TR-82-21, March 1982.
2. Auburn, J. N. and Margulies, G.: Low-Authority Control Synthesis for Large Space Structures. Langley Research Center, NASA CR 3495, September 1982.
3. ACOSS FOURTEEN, (Active Control of Space Structures) Final Technical Report, Rome Air Development Center, Griffiss AFB, NY, Report No. RADC-TR-83-51, March 1983.
4. Waites, H. and Worley, H. E.: Large Space Structures Testing. NASA TM 100306, June 1987.

APPROVAL

AN APPLICATION OF "HIGH AUTHORITY/LOW AUTHORITY
CONTROL" AND "POSITIVITY"

By S. M. Seltzer, D. Irwin, D. Tollison
and H. B. Waites

The information in this report has been reviewed for technical content. Review of any information concerning Department of Defense or nuclear energy activities or programs has been made by the MSFC Security Classification Officer. This report, in its entirety, has been determined to be unclassified.

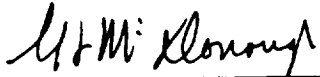

G. F. McDONOUGH
Director, Structures and Dynamics Laboratory



1. REPORT NO. NASA TM-100338		2. GOVERNMENT ACCESSION NO.		3. RECIPIENT'S CATALOG NO.	
4. TITLE AND SUBTITLE An Application of "High Authority/Low Authority Control" & "Positivity"			5. REPORT DATE August 1988		
			6. PERFORMING ORGANIZATION CODE		
7. AUTHOR(S) S. M. Seltzer,* D. Irwin,* D. Tollison,* and H. B. Waites			8. PERFORMING ORGANIZATION REPORT #		
9. PERFORMING ORGANIZATION NAME AND ADDRESS George C. Marshall Space Flight Center Marshall Space Flight Center, AL 35812			10. WORK UNIT NO.		
			11. CONTRACT OR GRANT NO.		
12. SPONSORING AGENCY NAME AND ADDRESS National Aeronautics and Space Administration Washington, D.C. 20546			13. TYPE OF REPORT & PERIOD COVERED Technical Memorandum		
			14. SPONSORING AGENCY CODE		
15. SUPPLEMENTARY NOTES Prepared by Structures and Dynamics Laboratory, Science and Engineering Directorate. *Control Dynamics Company, Huntsville, Alabama					
16. ABSTRACT Control Dynamics Company (CDy), in conjunction with NASA Marshall Space Flight Center (MSFC), has supported the U.S. Air Force Wright Aeronautical Laboratory (AFWAL) in conducting an investigation of the implementation of several Department of Defense controls techniques. These techniques are to provide vibration suppression and precise attitude control for flexible space structures. AFWAL issued a contract to Control Dynamics to perform this effort under the Active Control Technique Evaluation for Spacecraft (ACES) Program. Dr. Henry B. Waites (MSFC) was the Principal Investigator. Dr. George B. Doane III (CDy) was the Program Manager, and Dr. R. Dennis Irwin (formerly CDy, presently Ohio University) was the Project Leader. The "High Authority Control/Low Authority Control" (HAC/LAC) and "Positivity" controls techniques, which were cultivated under the DARPA Active Control of Space Structures (ACOSS) Program, were applied to a structural model of the NASA/MSFC Ground Test Facility ACES configuration. Mr. Danny K. Tollison performed the HAC/LAC evaluation, and Mr. Jeffrey Lucas performed the Positivity evaluation. The control system designs were accomplished and linear post-analyses of the closed-loop systems are provided. The control system designs take into account effects of sampling and delay in the control computer. Non-linear simulation runs were used to verify the control system designs and implementations in the facility control computers. Finally, test results are given to verify operations of the control systems in the test facility.					
17. KEY WORDS Large Space Structures Modeling Dynamic Verification Automatic Controls			18. DISTRIBUTION STATEMENT Unclassified - Unlimited		
19. SECURITY CLASSIF. (of this report) Unclassified		20. SECURITY CLASSIF. (of this page) Unclassified		21. NO. OF PAGES 14	22. PRICE NTIS

