

NASA Technical Memorandum 101017

Facility for Interferometric Testing of 1.25-m Mirrors at Liquid Helium Temperatures

Louis J. Salerno and Ramsey K. Melugin

(NASA-TM-101017) FACILITY FOR
INTERFEROMETRIC TESTING OF 1.25-m MIRRORS AT
LIQUID HELIUM TEMPERATURES (NASA) 14 p
CSCL 20F

N89-12398

Unclas

G3/74 0174648

October 1988

NASA

National Aeronautics and
Space Administration

Facility for Interferometric Testing of 1.25-m Mirrors at Liquid Helium Temperatures

Louis J. Salerno
Ramsey K. Melugin, Ames Research Center, Moffett Field, California

October 1988



National Aeronautics and
Space Administration

Ames Research Center
Moffett Field, California 94035

FACILITY FOR INTERFEROMETRIC TESTING OF 1.25-m MIRRORS AT LIQUID HELIUM TEMPERATURES

Louis J. Salerno and Ramsey K. Melugin

NASA Ames Research Center, Infrared Astronomy Projects Office
Moffett Field, California 94035

SUMMARY

A concept is presented for a national cryogenic optics test facility capable of optical characterization of 1.25-m-diameter optics having focal lengths up to 6.2 m at temperatures from 300 K to near 4 K. The facility will be comprised of a large Dewar with a phase-shift interferometer, a two-stage vacuum system employing a turbomolecular pump, and an integral vibration isolation system. The entire facility will be housed in a concrete site with a massive floor to assist in reducing vibration during optical tests. By providing interchangeable sections, the overall height of the Dewar can be adjusted to provide for testing of shorter focal length optics.

This paper discusses the background for the facility, the facility location, and the requirements and the performance considerations which drive the Dewar design with respect to the vibration isolation system, vacuum system, and optical interferometry.

INTRODUCTION

The requirement has arisen to cryogenically test large optics, in particular 0.5-m to 1.25-m-diameter mirrors. Mirrors in this size range will be used in such proposed projects as the Space Infrared Telescope Facility (SIRTF) (ref. 1), and the Large Deployable Reflector (LDR) (ref. 2).

An existing Cryogenic Optics Test Facility (ref. 3), at Ames Research Center (ARC) utilizes a three-section, dual-cryogen Dewar of 2.75 m overall height and 0.91 m overall diameter. The Dewar is suspended from the ceiling by a harness-and-winch assembly mounted to a frame supported on air-cushion vibration isolators. The top section contains the two cryogen tanks and the inverted cold plate. A clear optical path length of 2.06 m is available from the cold plate to the window. Mirrors up to 0.66 m in diameter can be tested down to near 4 K. Because the existing facility is unable to test optics beyond that diameter, the requirement evolved for developing a new Dewar capable of handling optics from 0.5 m to 1.25 m.

The site of the existing facility is unable to house the new Dewar; therefore, it was necessary to select a new site to accommodate both Dewars.

The new facility will be located at ARC, and will contain the cryogenically cooled Dewar system, interferometer, and vibration isolation system. The facility is presently in the definition stage, and an artist's rendering is shown in figure 1.

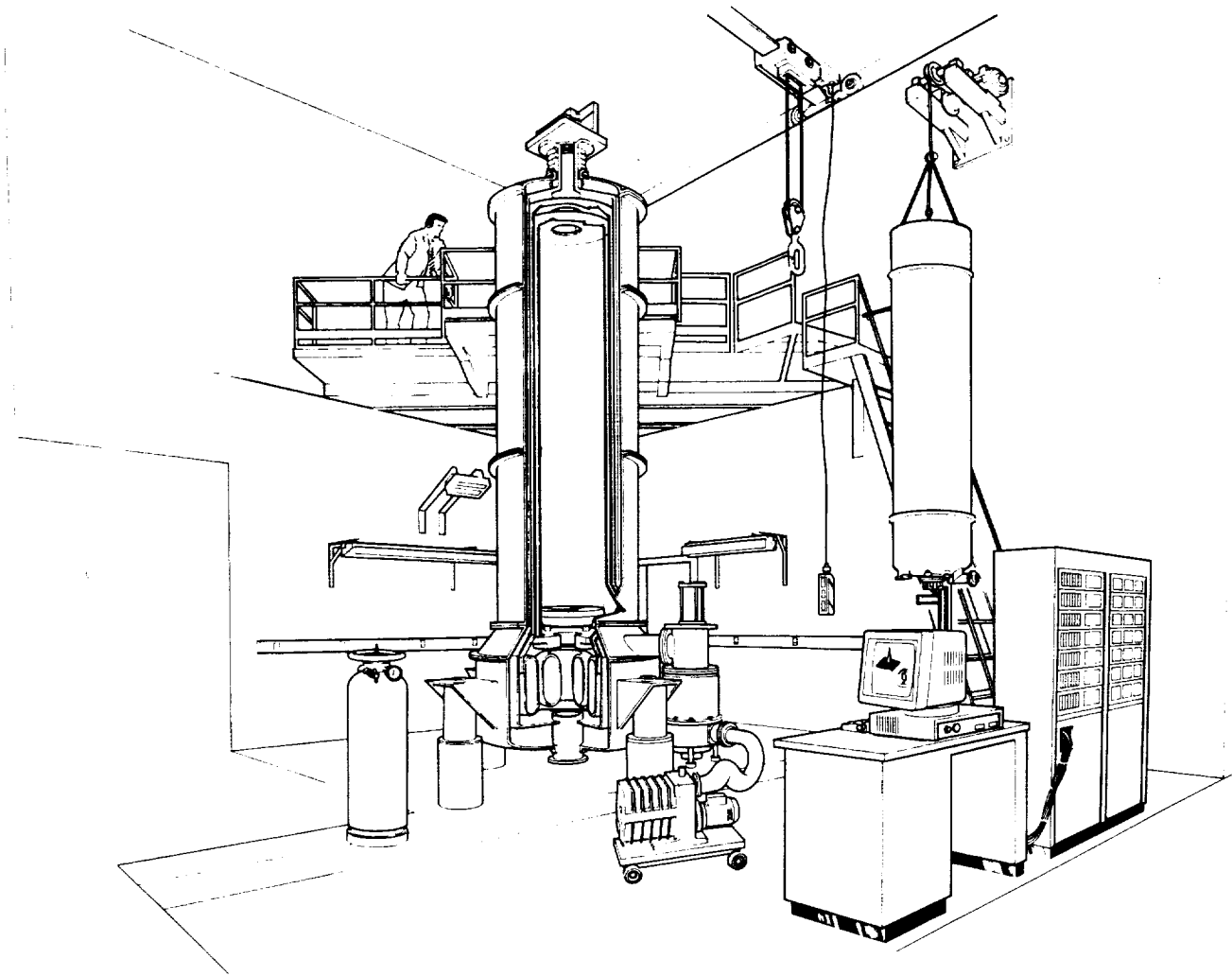

Figure 1.— Artist's rendering of 1.25-m cryogenic optics facility.

The Dewar, containing both liquid nitrogen (LN_2) and liquid helium (LHe) tankage in a nested toroidal arrangement, is oriented vertically. Testing at room temperature is planned, and by appropriate selection of cryogens, bath temperatures of 77 K or 4.2 K are attainable. A cold plate is provided to mount test articles. Windows at each end of the Dewar permit optical access for the interferometer from either the top or bottom.

The Dewar concept permits testing of concave mirrors up to 1.25 m in diameter at their center of curvature at temperatures near 4 K. The maximum clear optical path from the mirror to the interferometer is 6.2 m. This will accommodate an $f/2.5$, 1.25-m-diameter mirror. With interchangeable sections, reduced focal lengths are easily accommodated.

FACILITY LOCATION

The facility will be located in a building selected on the basis of several unique aspects. The building is a monolithic concrete structure isolated from an adjacent building and has walls and ceiling 0.30 m (1 ft) thick and a reinforced concrete floor 0.91 m (3 ft) thick. The mass of the building is approximately 489,000 kg. It offers 69.7 m² (750 ft²) of floorspace. A portion of this area will be used for workrooms and office space. Because the available height is nearly 9 m, the office area could be elevated, providing storage space beneath. The existing 907-kg (1 ton) traveling crane will be replaced with a 4536-kg (5-ton) unit. The existing 0.7-m facility will be moved to this location to utilize common test instrumentation.

DEWAR SYSTEM

A tradeoff study was performed to determine the optimum size for the larger Dewar, based on the optical diameter/focal length requirements of candidate optics and the limitations of the location. In particular, the SIRTf baseline has a primary mirror diameter of approximately 92 cm with a focal length of 195.5 cm (radius of curvature 3.91 m); however, the capability to test 1.25-m-diameter mirrors at $f/2.5$ as previously stated, is planned for growth potential.

For example, a center of curvature test for a 1.25-m-diameter, $f/2.5$ mirror requires a clear optical path from the interferometer to the mirror vertex of 6.25 m and an inside diameter of 1.37 m. To test a 1.0-m-diameter $f/1$ mirror, the optical path is reduced to 2.0 m. After examination of all factors involved, the larger Dewar was baselined for a configuration of 1.25-m-diameter $f/2.5$ optics.

Next the question of configuration was addressed. Various concepts for the Dewar were examined, among them horizontal, vertical, rotatable, floor-mounted, and suspended. Figure 2 shows the configurations of a suspended facility (to scale) that were considered. The concept selected is floor-mounted, vertical, and is approximately 2.1 m in diameter and 7.6 m in height. In addition to convenient access to the test article and cryogen loading, the floor mounting provides a stable equilibrium position for the Dewar.

The bottom section of the Dewar provides the cold plate for mounting a test article such as a mirror, and houses two cryogen tanks. The outer toroidal tank holds LN₂. The inner tank can hold LN₂ or LHe. The lowest temperature expected for the cold plate is about 4 K. Should different temperatures be required for characterization of particular optics, noble gases such as argon (87.3 K) and neon (27.2 K) may be used, although admittedly at much greater cost.

The cold plate is shown conceptually in figure 3. The approximate dimensions are 0.63 m inside diameter (ID) and 1.32 m outside diameter (OD). The annular form allows passing an interferometer beam through the center. The cold plate will be made of aluminum, surfaced flat, and will have six equally spaced radial "tee" slots spanning ID to OD. The surface area bounded by any two adjacent slots is to be filled with an "even inch" rectilinear array of tapped holes. The top surface of the cold plate (optic mounting surface) is between 1.52 m and 1.83 m from the floor to provide a convenient working level.

The cryogenic performance requirements call for a cooldown of the cold plate from 300 K to LN₂ temperatures (77 K) in 36 hr, and further cooldown to LHe temperatures (4.5 K or less) within an additional 36 hr.

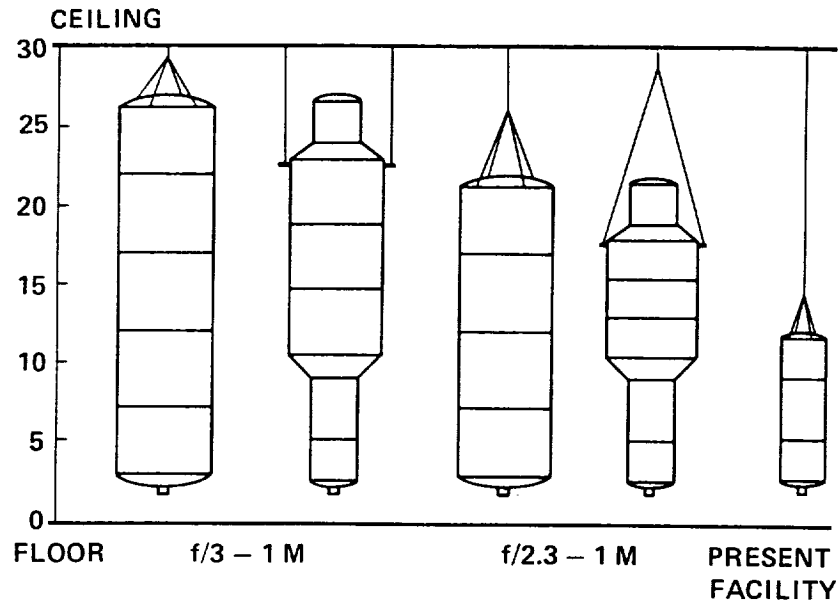

Figure 2.— Dewar configuration concepts.

The extension sections will contain approximately 2.0 m of LN₂ and LHe shielding. Above this, LN₂ shielding is sufficient, and for the final section containing the interferometer window, no shielding is required. Service flanges will be provided at both Dewar ends for internal accessibility. Each section will contain provisions for independent handling by a crane at the facility location, thereby assuring maximum modularity.

Those portions of the LN₂ cold shields extending farthest from the tanks are required to be cooled to less than 80 K within 24 hr of tank fill. The LHe cold shields are required to be cooled to less than 8 K within 24 hr of LHe tank fill. These requirements apply regardless of whether the Dewar is empty or contains a test article. Associated with cooldown is the hold time requirement, defined as the time from tank top off to a specified low cryogen gas flow after a 36 hr equilibration cooldown. The requirement calls for a hold time of 18 hr for LN₂ and 24 hr for LHe.

Vacuum System

The vacuum system consists of a 42.5 liter/sec (90 cfm) mechanical roughing pump coupled to an 1800 liter/sec (850 cfm) turbomolecular pump. The system is required to evacuate the Dewar from 760 torr to 5 x 10E-4 torr with 24 hr and down to 1 x 10E-4 torr within 1 wk. A separate roughing line allows roughing the chamber directly and has a molecular sieve trap to prevent Dewar contamination through the pumping system. Two 30-cm (12-in.) pump-out ports for the vacuum pumps are located near the bottom of the Dewar. This allows additional access or the option of adding another turbomolecular pump, should it be desired. Both thermocouple (TC) and ionization gauges (IG) are employed for monitoring pressure. Nude-type IGs ensure the absence of pressure drop effects from connecting tubing. Gauges are to be located more than 12 in. from pump-out ports and as far as possible from cold shields,

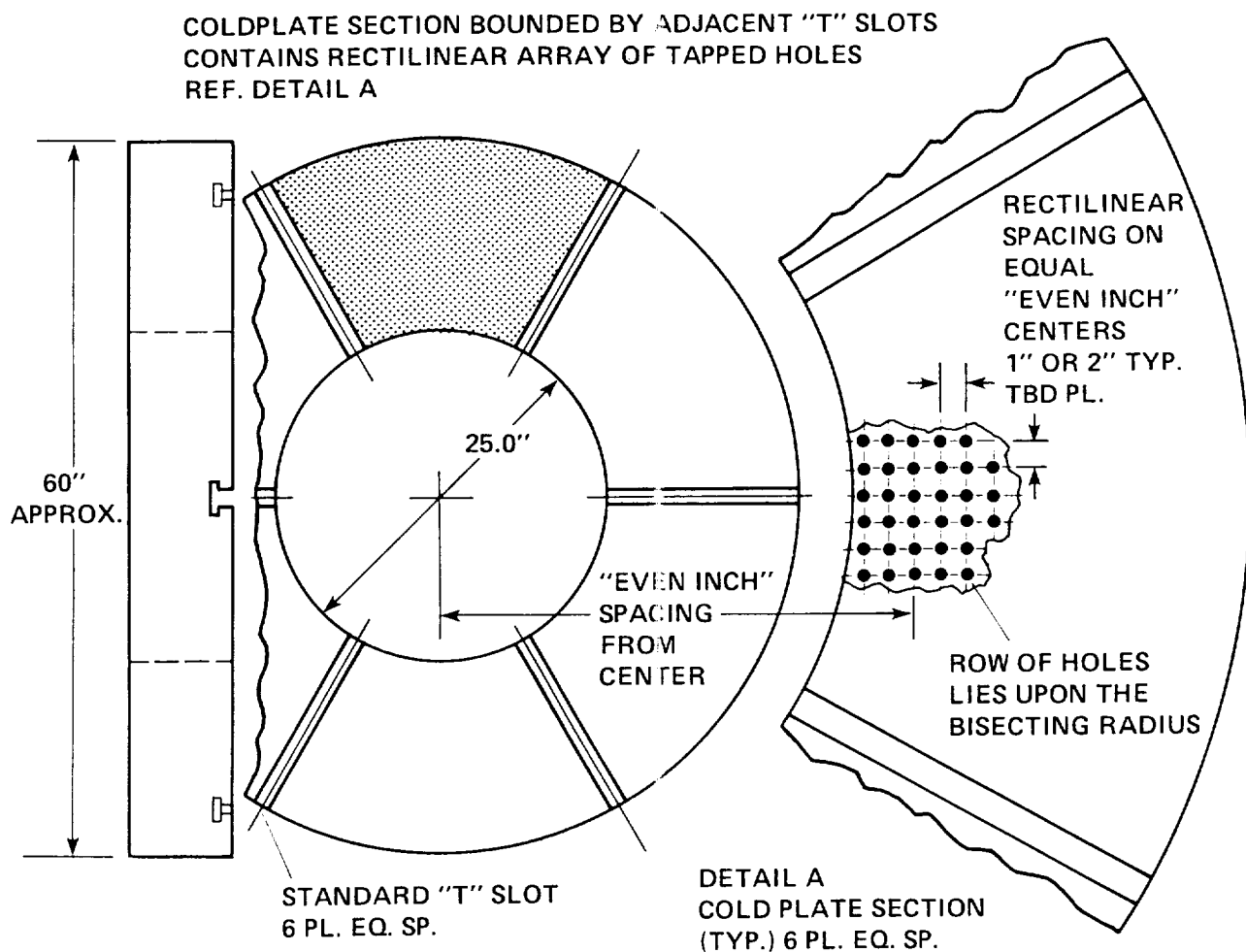

Figure 3.— Cold plate.

multilayer insulation (MLI), or other outgassing sources. The vacuum system schematic is shown in figure 4.

The ability to achieve a sufficiently low vacuum in the Dewar raises concerns over leakage and molecular contamination (hydrocarbons, water, etc.). The requirement for leakage and outgassing specifies a limitation on pressure rise in the Dewar after valving off the vacuum system of 5×10^{-3} torr in 24 hr from a starting pressure of 10^{-3} torr.

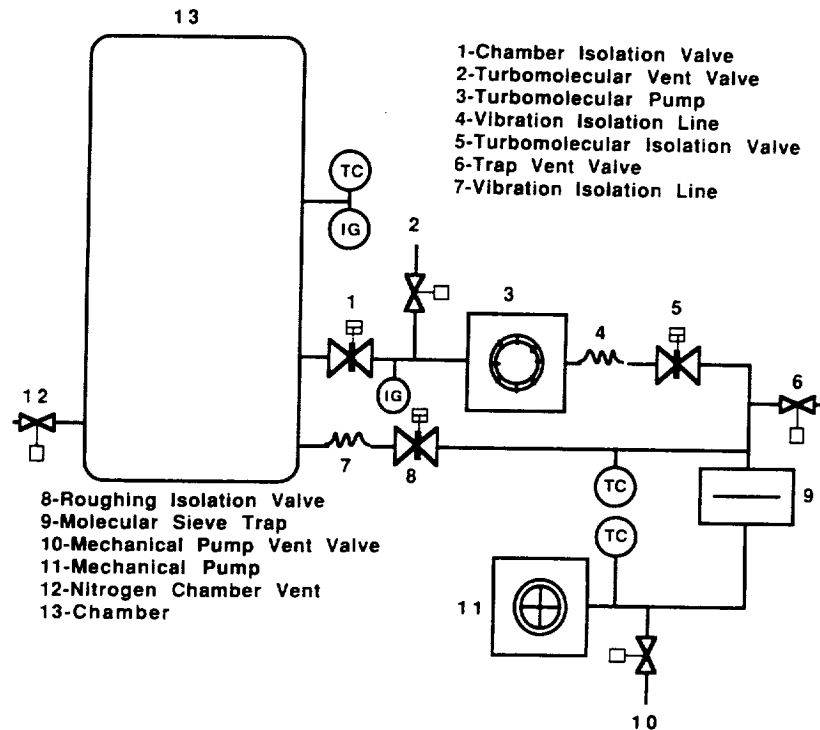

Figure 4.- Vacuum system.

Vibration Isolation

The Dewar must be sufficiently rigid so the relative motion of the test optic, with respect to the interferometer, will permit phase-shift interferometry measurements of 0.15 sec duration with statistical errors below 0.05- μm root-mean-square and systematic errors below 0.02- μm root-mean-square. Optical requirements dictate that for a 0.07-sec exposure, this condition will be met if: 1) the axial distance between the test optic and the interferometer is maintained without variations greater than 0.05- μm root-mean-square; 2) the lateral position of the test optic with respect to the interferometer is maintained without variations greater than 0.04- μm root-mean-square; 3) the tilt of the test optic with respect to the line through its center and the center of the interferometer beam is maintained without variations greater than 0.02 arcseconds; and 4) there are no resonant frequencies of the structure, creating relative motion of the test optic and interferometer, in the range from 20 Hz to 45 Hz.

Vibration measurements obtained for the proposed site location employing floor-mounted accelerometers are shown in figure 5 for the north-south, east-west, and vertical axes. The measurements were obtained using a Hewlett-Packard 5423A Dynamic Analyzer and two Sundstrand accelerometers. The spectrum from 0 to 400 Hz was divided into 256 channels or "bins," each approximately 1.56 Hz wide. Data were logged every 20 min, the value recorded being the highest amplitude occurring in the bin over the 20-min data-collection period. Overall, there is less than 0.8 mg disturbance from 0-400 Hz. Additional measurements are being made to provide a power spectral density characterization of the vibration environment.

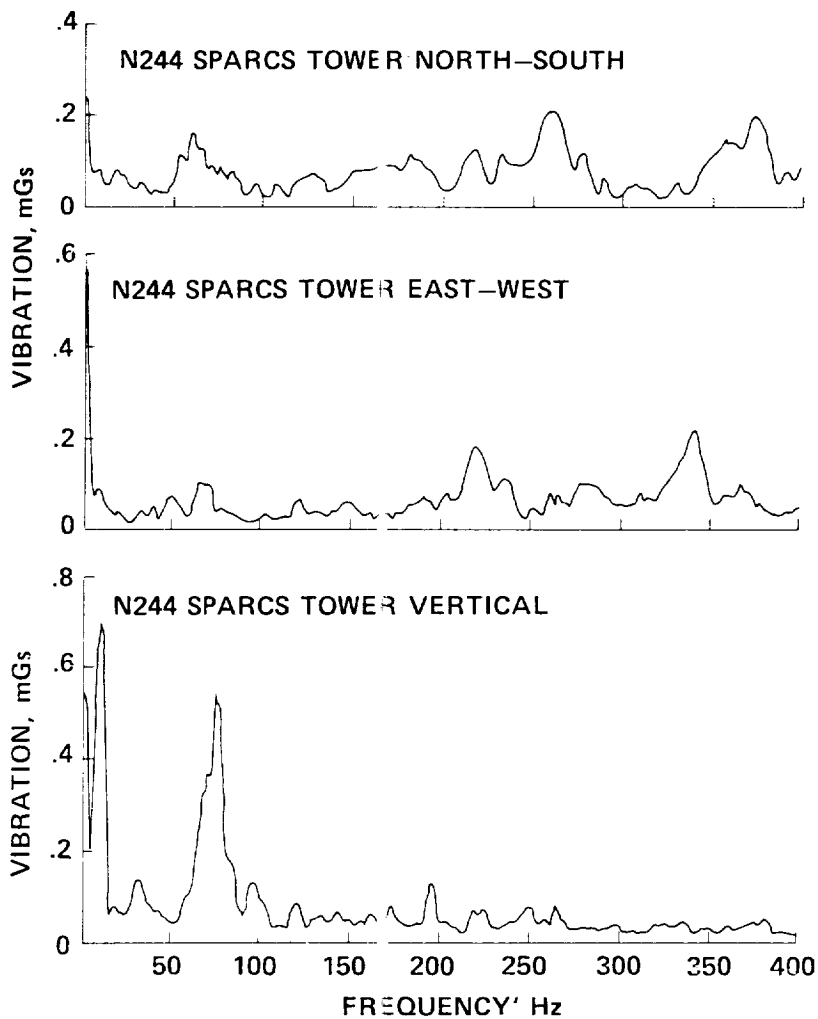

Figure 5.— Vibration measurements at facility site.

Isolation of the test optic/interferometer from the subject vibration spectra requires an isolation system. Such a system would be integrated with the Dewar supports. The system must provide not only vibration isolation, but, also for convenience, it must position the Dewar between 0.45 m (18 in.) and 0.76 m (30 in.) above the floor.

Metrology Structure

Attaining the degree of vibration isolation required for accurate long-path-length interferometry with a multisegmented structural design is a system challenge. Obtaining the requisite structural rigidity from cold plate to interferometer via bolted flange-style joints with O-ring seals in the presence of acoustically induced vibration isolation is a major concern. Consequently, part of the design concept utilizes an inter-

nal metrology structure as an interferometric test bed. Figure 6 presents a simple metrology structure concept.

Conceptually, the structure is located within the vacuum vessel, but goes around the cold shrouds and cryogen reservoirs and operates near room temperature. As such, the structure does not support the shrouds or reservoirs; however, it does support the test mirror, mirror mount, cold plate, optical windows, and external interferometric test equipment.

The structure is thermally isolated from the mirror and cold plate assemblies, mechanically uncoupled from the cold shrouds and cryogen reservoirs and from the vacuum vessel at vessel penetrations by flexible bellows, and vibrations isolated by the external isolators.

The structure design is required to be compatible with the modular Dewar concept, and with the use of standard and facility-dedicated handling equipment.

Shutters

Mechanical cold shutters are required in the optical path to control test mirror view factors to external heat sources, specifically the optical window and the interior of the LN₂ shroud. Shutter surfaces must have an emissivity greater than 0.9 for the interior surfaces and an emissivity less than 0.1 for the exterior surfaces. The figures cover the range from $\lambda = 2$ to 14 μm . Eighteen layers minimum of MLI are to be used for insulation. The shutters must be capable of fully retracting to permit periodic optical interferometry of the test mirror without vignetting.

A shutter concept is shown in figure 7.

PLANS

The facility is described above through a combination of concepts and performance requirements. A Request For Proposal will be released in 1988 and will define the exact requirements. It is estimated that acceptance testing will be under way in 1989 and the facility will be ready for operation by early 1990. Utilization of the facility by other agencies or businesses will be accommodated.

ORIGINAL PAGE IS
OF POOR QUALITY

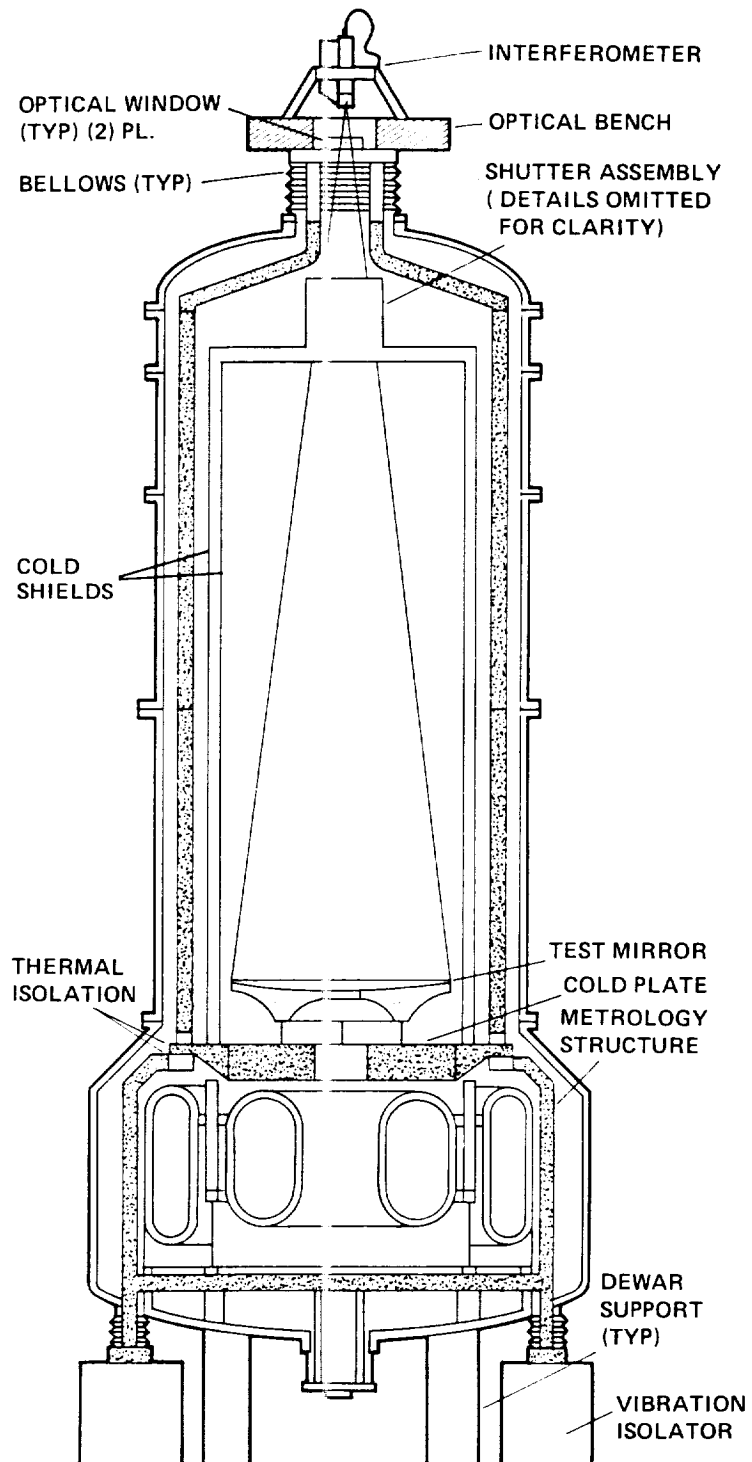

Figure 6.- Metrology structure concept.

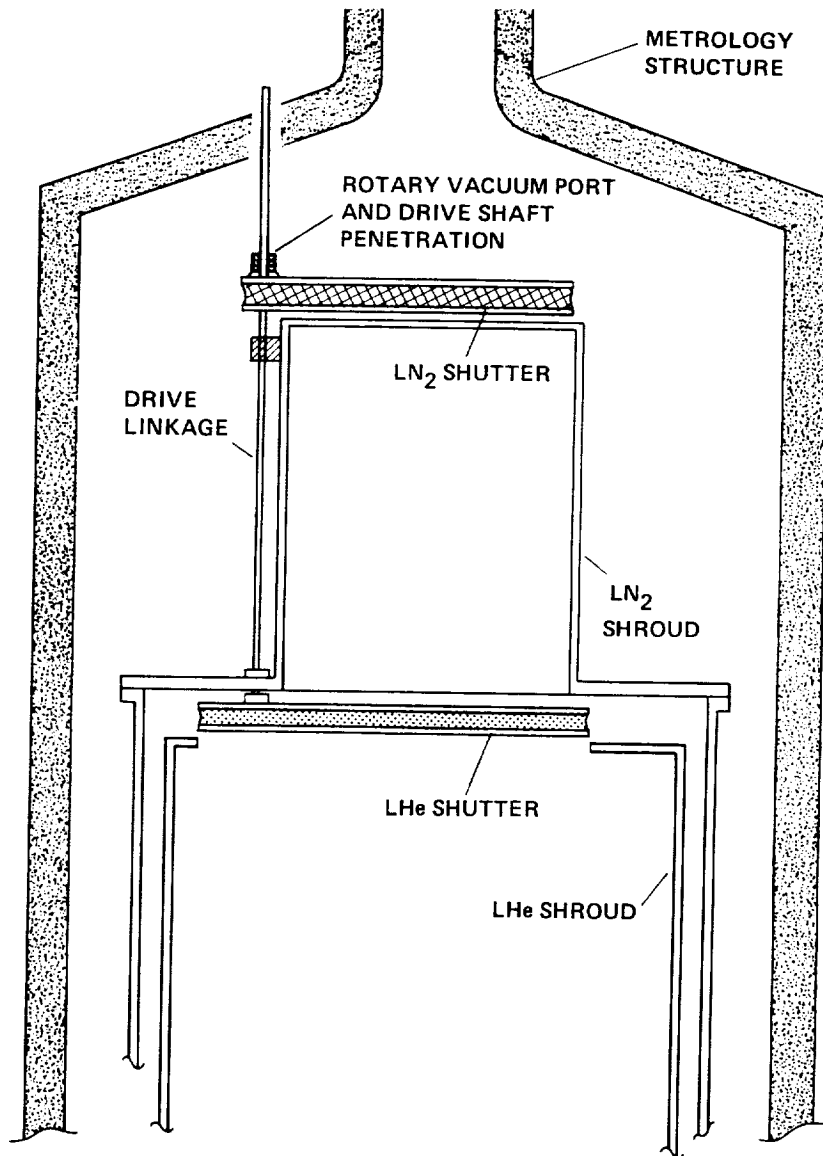

Figure 7.- Shutter concept.

REFERENCES

1. Werner, M. W.; Murphy, J. P.; Witteborn, F. C.; and Wiltsee, C. B.: The SIRTf Mission, Instrumentation for Optical Remote Sensing from Space, Proc. SPIE 589, 1985, pp. 210-221.
2. Nishioka, K., ed: Workshop on Technology Development Issues for the Large Deployable Reflector (LDR), NASA Conference Paper 2407, 1986.
3. Miller, J. H.; Witteborn, F. C.; and Garland, H. J.: Cryogenic Testing of Mirrors for Infrared Space Telescopes, in Advanced Technology Optical Telescopes, Proc. SPIE 332, 1982, pp. 413-418.



Report Documentation Page

1. Report No. NASA TM-101017		2. Government Accession No.		3. Recipient's Catalog No.	
4. Title and Subtitle Facility for Interferometric Testing of 1.25-m Mirrors at Liquid Helium Temperatures				5. Report Date October 1988	
				6. Performing Organization Code	
7. Author(s) Louis J. Salerno and Ramsey K. Melugin				8. Performing Organization Report No. A-88253	
9. Performing Organization Name and Address Ames Research Center Moffett Field, CA 94035				10. Work Unit No. 159-41-06	
				11. Contract or Grant No.	
12. Sponsoring Agency Name and Address National Aeronautics and Space Administration Washington, DC 20546-0001				13. Type of Report and Period Covered Technical Memorandum	
				14. Sponsoring Agency Code	
15. Supplementary Notes Point of Contact: Louis J. Salerno, Ames Research Center, MS 244-10 Moffett Field, CA 94035 (415) 694-3189 or FTS 464-3189					
16. Abstract A concept is presented for a national cryogenic optics test facility capable of optical characterization of 1.25-m-diameter optics having focal lengths up to 6.2 m at temperatures from 300 K to near 4 K. The facility will be comprised of a large Dewar with a phase-shift interferometer, a two-stage vacuum system employing a turbomolecular pump, and an integral vibration isolation system. The entire facility will be housed in a concrete site with a massive floor to assist in reducing vibration during optical tests. By providing interchangeable sections, the overall height of the Dewar can be adjusted to provide for testing of shorter focal length optics. This paper discusses the background for the facility, the facility location, and the requirements and the performance considerations which drive the Dewar design with respect to the vibration isolation system, vacuum system, and optical interferometry.					
17. Key Words (Suggested by Author(s)) Cryogenic optics Optical interferometry			18. Distribution Statement Unclassified-Unlimited Subject Category - 74		
19. Security Classif. (of this report) Unclassified		20. Security Classif. (of this page) Unclassified		21. No. of pages 12	22. Price A02