

NASA Technical Memorandum 101366

A Probabilistic Approach to Composite Micromechanics

T.A. Stock, P.X. Bellini,
and P.L.N. Murthy
Cleveland State University
Cleveland, Ohio

and

C.C. Chamis
Lewis Research Center
Cleveland, Ohio

(NASA-TM-101366) A PROBABILISTIC APPROACH
TO COMPOSITE MICROMECHANICS (NASA) 21 P
CSCL 11D

N89-12684

G3/24 Unclas
0177206

Presented at the
29th Structures, Structural Dynamics and Materials Conference
cosponsored by the AIAA, ASME, ASCE, AHS, and ACS
Williamsburg, Virginia, April 18-20, 1988





A PROBABILISTIC APPROACH TO COMPOSITE MICROMECHANICS

T.A. Stock,* P.X. Bellini, and P.L.N. Murthy
Cleveland State University
Cleveland, Ohio 44115

and

C.C. Chamis
National Aeronautics and Space Administration
Lewis Research Center
Cleveland, Ohio 44135

SUMMARY

A probabilistic approach to composite micromechanics is developed that simulates uncertainties in unidirectional fiber composite properties. These methods are in the form of computational procedures using Monte Carlo simulation. The variables for which uncertainties are accounted include constituent and void volume ratios, constituent elastic properties and strengths, and fiber misalignment (primitive variables). A graphite/epoxy unidirectional composite (ply) is studied to incorporate fiber composite material properties uncertainties at the micro level. Probabilistic composite micromechanics provides extensive information which formally relates ply phenomenological behavior to a large number of complex and interacting uncertainties at the constituents level.

INTRODUCTION

Properties of composite laminates depend on the properties of the constituent materials, their distribution, and orientation. Laminates are composed of layers of unidirectionally reinforced plies (lamina). The ply is typically considered the basic unit of material in composite mechanics. The branch of composite mechanics that predicts ply material properties based on the properties, volume, and orientation of its constituents is known as composite micromechanics, and frequently incorporates the traditional Mechanics of Materials assumptions. The desired laminate is created by stacking piles in specific directions. The integration of ply properties to yield laminate properties is called laminate theory. Laminate variables such as ply orientation and stacking sequence can be tailored to yield a laminate with the desired material properties. Thus, the laminated composite is a suitable material for component design.

Analysis of fiber composite structures is currently performed using a variety of computer codes. Complete mechanical, thermal, and hygral properties are calculated, and can be used to compute respective structural responses. Advanced failure criteria are used to calculate composite strengths. Environmental effects are also quantified. The usefulness of these codes has been demonstrated by comparison with experimental data and finite element results. (ref. 1)

*Presently at Wright-Patterson Air Force Base, Dayton, Ohio 45433.

The analytical capability of these codes is limited by the deterministic nature of the computations, while corresponding measured data exhibit considerable scatter. Specifically, fixed values for constituent material properties, fabrication process variables (i.e., constituent volume ratios), and internal geometry (primitive variables) are used as input. However, random variations in these parameters are not only expected, but easily observed experimentally.

The analysis of composite structures requires reliable predictive models for material properties and strengths. However, the prediction efforts have been complicated by inherent scatter in experimental data. Since uncertainties in the constituent properties, fabrication variables, and internal geometry would lead to uncertainties in the measured composite properties, the question arises:

How much of the "statistical" scatter of experimentally observed composite properties can be explained by reasonable statistical distribution of input parameters in composite micromechanics and laminate theory predictive models?

In order to answer this question, a study was conducted to develop a probabilistic approach to composite micromechanics. The objective of the present paper is to describe this approach and present typical results. The computational simulation is performed using ply substructuring with an existing computer code (ref. 2) for composite mechanics and in conjunction with Monte Carlo simulation. The randomness in the primitive variables is selected from anticipated respective probabilistic distributions. These distributions have the same mean as the deterministic case. In this context, the deterministic micromechanics will predict only the mean while probabilistic will predict the mean and respective scatter.

SYMBOLS

E normal modulus - subscripts define type and direction

FVR fiber volume ratio

G shear modulus - subscripts define type and direction

S fracture stress (strength) - subscripts define type and direction

VVR void volume ratio

Greek

α thermal expansion coefficient - subscripts define type and direction;
also shaped coefficient the Weibull distributions

β mean value in the Weibull distribution

γ special probabilistic distribution

κ shape coefficient in the I distribution

- λ mean value in the Γ distribution
- μ mean value in the normal distribution
- ν Poisson's ratio - subscripts define type and direction
- σ standard deviation

Subscripts

- c compression
- f fiber property
- l ply property
- M matrix property
- S shear
- T tension
- 1 fiber direction and surface normal to this direction
- 2 transverse fiber direction and surface normal to this direction
- 3 thickness direction and surface normal to this direction

COMPUTATIONAL SIMULATION FUNDAMENTALS

Analysis Model - Basic Unit

The models commonly used in characterizing fiber composites structural behavior are based on the calculation of properties of the basic unit of an orthotropic ply. The layup geometry is then used in laminate equations to calculate composite properties (fig. 1). In the present work, however, the basic unit is taken as a sub-ply (ply substructuring), which consists of only one fiber-matrix level in the material (fig. 2(a)). Micromechanics theory is used to calculate the properties of the assumed orthotropic sub-ply, each with randomly distributed fabrication variables (fiber volume ratio and fiber misalignment) and material properties. Uncertainties in fiber directions, due to possible misalignment within the ply, are then used in the laminate equations to calculate ply properties. The substructuring of the ply represents a novel attempt at characterization of fiber composite material properties based on probabilistically distributed constituent properties, individual fiber misalignment (fig. 2(b)) and fabrication process (primitive) variables.

This formulation is particularly well suited to probabilistic description of fiber composite material properties. The micromechanics and laminate theory equations can be used to calculate ply properties at any number of points in a ply. The approach provides a computationally rational procedure for evaluating the scatter in composite material properties because it evaluates ply

behavior as the result of a series of random occurrences (uncertainties in the primitive variables) which occur at the intraply or micromechanics level.

Composite Mechanics

The simulation is performed by considering the ply as an assembly (equivalent laminate) of 15 subplies. The composite mechanics used in the simulation is that embodied in the Integrated Composite Analyzer (ICAN) (ref. 2), which is a computer program for comprehensive linear analysis of multilayered fiber composite structures. The program contains the essential features required to effectively design structural components made from fiber composites. It now represents the culmination of research conducted since the early 1970's, at the National Aeronautics and Space Administration (NASA) Lewis Research Center, to develop and code reliable composite mechanics theories. Through this simulation the following are included and can be evaluated probabilistically:

- (1) Conventional laminate analysis
- (2) Intraply and interply hybrid composites
- (3) Hygral, thermal, mechanical properties and response
- (4) Ply stress-strain influence coefficients
- (5) Microstresses and microstress influence coefficients
- (6) Stress concentration factors around a circular hole
- (7) Predictions of delamination locations around a circular hole
- (8) Poisson's ratio mismatch details near a straight free edge
- (9) Free edge interlaminar stresses
- (10) Laminate failure stresses
- (11) Normal and transverse shear stresses
- (12) Explicit specification of matrix-rich interply layers
- (13) Finite element material cards for general purpose finite element structural analysis

Probabilistic Simulation - Monte Carlo Methods

Complicated stochastic (probabilistic) processes can be simulated by a variety of numerical methods generally referred to as Monte Carlo methods (ref. 3). The term refers to that branch of mathematics concerned with numerical experiments on random numbers. Since the advent of high speed computers, they have found extensive use in most fields of science and engineering, in analyzing many physical processes of a probabilistic nature, or where physical experimentation is not feasible. In general, they can be economically used to achieve a level of confidence of greater than 90 percent.

A Monte Carlo simulation refers to the procedure of randomly assigning a value to an independent random variable in a chosen model, and observing the dependent variable at the conclusion of the process being modeled. A Monte Carlo simulation is composed of n such independent experiments. When n is sufficiently large, the observations will yield a statistically meaningful estimate of the model dependent variable.

The form of Monte Carlo used in the present investigation is as follows:

- (1) Define the system model by assuming:
 - (a) Probability distributions for the scatter in all independent (primitive) variables.
 - (b) The equations used to model the composite thermal and mechanical behavior properly describe the physics.
- (2) Use the random sampling techniques to select input values of the independent variables from their assumed probabilistic distributions (1(a) above).
- (3) Calculate dependent (output) variables using the equation. (1(b) above).
- (4) Estimate regression parameters (goodness of fit tests) for the assumed model.
- (5) Replicate the procedure, each time with a new set of input values, using the procedure in (2) above.
- (6) Use appropriate statistical methods to calculate properties of the dependent variable distributions such as means and standard variations (results of this step are not included in this paper).

Computational Simulation Procedure

To perform the computational simulation, a computer code was developed to ICAN and an available statistical analysis code (ref. 4). The logic for this code is shown in figure 3. The steps are as follows:

- 1) Select values for the primitive variables for each subply from their respective assumed probabilistic distributions:
 - (a) Normal with selected variations - constituent elastic properties and fiber volume ratio, and fiber misalignment
 - (b) Weibull - constituent strengths
 - (c) Gamma - for void volume ratio

Fifteen different sets are generated (one for each subply) where the means and variation ranges selected for the fourteen primitive random variables are those typical for AS-graphite fiber/epoxy composites as listed in table 1. The deterministic case is also shown. Note that the deterministic case values are the same as the means for the other two cases.

- (2) Enter these values as inputs into ICAN.
- (3) Run ICAN and retrieve and store ICAN output for desired ply properties.
- (4) Repeat process n-times where n is sufficiently large to provide data with an acceptable level of confidence. For the results presented here n equal 50 was considered adequate.
- (5) Graphically stored output for probability density and cumulative probability distributions.

Additional details and rationale are described in reference 5.

RESULTS AND DISCUSSION

Results obtained from probabilistic composite micromechanics are voluminous. These results can be presented in several alternative ways. A meaningful way to present them is in terms of (1) histograms (frequency or probability of density) and (2) cumulative distribution. The histograms indicate the range of the scatter while the cumulative distribution indicates the probability of occurrence. The graphical results presented for the ply properties are (1) moduli (longitudinal, transverse, shear and Poisson's ratios, (2) thermal expansion coefficients (longitudinal and transverse), and (3) strengths (longitudinal tension and compression, transverse tension and compression and intralaminar shear). For comparison purposes the deterministic values for these same properties are listed in table II where the inputs for the deterministic values are from Case 1, table I.

Moduli

Longitudinal modulus (E_{011}) - The frequency and cumulative distribution diagrams for the longitudinal modulus are shown in figure 4. Case 2 and Case 3 refer to probabilistic inputs in table I. As would be expected, the greater the scatter in the primitive variables, the greater the scatter in the ply modulus Case 2 versus Case 3. For example, the scatter in the longitudinal modulus for Case 2 is from about 13.5 to 18.5 mpsi while that for Case 3 is from about 12.5 to 19.5 mpsi. The estimated means for the respective cases, taken at 50 percent probability of occurrence, are about 15.5 and 14.8 mpsi. Both of these are less than the deterministic case of 15.8 mpsi (table II).

A typical experimental value of modulus for this composite system is about 16 mpsi which is well within the range of the scatter for both cases. Assuming the scatter for the primitive variables is reasonable, the results show that experimental values for the longitudinal modulus as low as about 12.5 mpsi and as high as 19.5 mpsi are probable under present practice.

Transverse modulus (E_{022}) - The frequency and cumulative distribution diagrams for E_{022} are shown in figure 5. Focusing on the diagrams for Case 3, it is seen that the scatter for E_{022} is from the 1 to 1.3 mpsi with a mean value of 1.1 mpsi. This mean value is about the same as the 1.06 mpsi for the deterministic case. A typical experimental value is about 1.5 mpsi, which is greater than the highest value of 1.3 mpsi in the scatter range. One possible explanation is that the mean value used as input for the fiber

transverse modulus is lower than its actual value. This is readily corrected by a direct shift of the mean in the input value for E_{022} , or a mean ratio shift of (1.5/1.1) times the input value for E_{022} .

Assuming the scatter used for the primitive variables is reasonable, then, the anticipated scatter in measured values for E_{022} is about 20 percent. Variations greater than 20 percent are likely to arise from factors which were not considered in this investigation and which are not that obvious. This illustrates another important benefit of probabilistic composite micromechanics.

Shear modulus (G_{012}) - The frequency and cumulative distribution diagrams for G_{012} are shown in figure 6. One significant observation from these diagrams is that the means for the two cases differ by about 0.2 mpsi or about 30 percent. The scatter assumed for the primitive variables significantly affects the anticipated mean value of the ply shear modulus.

Looking at the diagrams for Case 3, we see that the scatter for G_{012} varies from about 0.6 to 1.4 mpsi with a mean of about 0.81 mpsi. The deterministic value is 0.52 mpsi (table II). The mean value is about the same as the lowest value in the scatter range. Three observations follow: (1) additional sampling points need to be included in plotting the diagrams, (2) the assumed scatter in the primitive variables (especially fiber misalignment) tends to increase the ply shear modulus relative to the deterministic case, and (3) a large scatter is probable in measured values for G_{012} . This latter point is consistent with experimental observations (ref. 1).

Poisson's ratio - The frequency and cumulative distribution diagrams for the major Poisson's ratio (ν_{012}) are shown in figure 7 and those for the minor (ν_{021}) are shown in figure 8. Examining the diagrams for Case 3 we see that the scatter for ν_{012} ranges from about 0.35 to 0.75 with a mean value of about 0.51. The deterministic value from table II is 0.28 which is less than the lower limit in the diagram. The observations to note are: (1) that the assumed scatter results in a substantially larger ν_{012} mean value compared to the deterministic value, and (2) that a substantial scatter is probable in the measured values for ν_{012} . The scatter and mean for ν_{021} exhibit similar trends as ν_{012} . This is expected because ν_{021} is not an independent quantity; it is calculated from the relationship $\nu_{021} = \nu_{012} E_{011}/E_{022}$.

Thermal expansion coefficients - The frequency and cumulative distribution diagrams for the thermal expansion coefficients are shown in figure 9 for longitudinal (α_{011}), in figure 10 for transverse (α_{022}), and in figure 11 for the coupling (α_{012}). This last coefficient exists primarily in the presence of scatter in the primitive variables which result in an unbalanced equivalent-laminate ply.

It is interesting to note that the diagrams for Case 2 exhibit less scatter than those for Case 3. This is primarily due to the probable fiber misalignment. From the Case 3 diagrams, the mean values for α_{011} , α_{022} , and α_{012} are -0.4, 16.5 and 0, $\mu\text{in./in./}^\circ\text{F}$, respectively. The corresponding deterministic values are about 0, 18.1 and 0, respectively. The smaller probabilistic value for α_{022} is mainly the result in the scatter of primitive variables. These diagrams indicate that measured values for α_{022} are likely to exhibit extensive scatter.

It is worth noting that neither the Poisson's ratios nor the thermal expansion coefficients for the constituents (primitive variables) are probabilistically defined. Yet the corresponding ply properties are probabilistic and with considerable scatter. This demonstrates the complex in situ interaction and interdependence of the various primitive variables and the need to develop a probabilistic approach to composite micromechanics.

Strengths

The ply probabilistic strengths are determined by assuming that the ply fractured when its weakest subply failed. This is equivalent to first ply failure for laminate fracture.

Longitudinal strengths - The frequency and distribution diagrams for the ply longitudinal tensile strength (S_{011T}) are shown in figure 12 and for the ply longitudinal compressive strength (S_{011C}) in figure 13. As can be seen the scatter in Case 3 is: (1) $80 \text{ ksi} < S_{011T} < 180 \text{ ksi}$ with a mean of about 130 ksi and (2) $40 \text{ ksi} < S_{011C} < 120 \text{ ksi}$ with a mean of about 75 ksi. The corresponding deterministic values from table II are 203 and 165 ksi, respectively. Both of these values are considerably greater than the highest value in the scatter range. These results are significant because of the following two points: (1) The ply does not fail when its weakest subply fails, otherwise the mean would have been close to the deterministic value. (2) The in situ mean tensile fracture stress of the fiber is considerably higher than the input value. Assuming a proportional (fiber strength/ply-strength, 203/130) the mean for the in situ fiber strength would be about 625 ksi which is about 56 percent higher than the input mean of 400 ksi. This higher value is representative of very small fiber gage lengths. Both of these lead to the general conclusion that ply fracture (strength) is a complex sequence of events which generally results in considerable penalty (reduction) relative to in situ fiber strength and which is inherently probabilistic. These remarks are applicable to the ply longitudinal compressive strength (S_{011C}) as well since it exhibits similar behavior.

Transverse strengths - The frequency and cumulative distribution diagrams for the transverse tensile ply strength (S_{022T}) are shown in figure 14 and for the compressive (S_{022C}) in figure 15. Referring to Case 3 diagrams, it can be seen that the scatter is relatively wide: (1) from about 0 ksi to about 7 ksi with a mean of 3 ksi for the transverse tensile strength, and (2) from about 0 to 16 ksi with a mean of 8 ksi for the transverse compressive strength. The corresponding values for the deterministic case from table II are 12 and 27 ksi, respectively. The remarks and discussion made for the longitudinal strengths are applicable to the transverse strengths as well, namely: (1) transverse ply fracture does not occur when the first subply fails and (2) transverse ply fracture is a complex sequence of events which are inherently probabilistic. An additional point to be noted is that the deterministic/probabilistic shift mean ratio is about 4 (12/3) for the transverse tensile ply strength and may be indicative of the micro damage tolerance of this strength.

Intralaminar (in-plane) shear - The frequency and cumulative distribution diagrams for the ply intralaminar shear strength (S_{012S}) are shown in figure 16. It can be seen from the Case 3 diagrams that the scatter is relatively wide from the 1 to 13 ksi with a mean of about 8 ksi. The corresponding

deterministic value from table II is 10 ksi. Again, this ply strength exhibits behavior similar to the other four. One noticeable exception is that this ply strength has the smallest mean shift ratio 1.25 of all five ply strengths indicating, perhaps, less brittle behavior for this strength compared to the other four.

Collectively, measured values on any or all of these strengths, would exhibit considerable scatter because of their inherent probabilistic nature. This scatter would be further accentuated because of the difficulty of performing the requisite tests. Though results are not presented here, confidence and significance of primitive variables are readily determined using standard statistical methods (ref. 3).

SUMMARY OF RESULTS

The salient results of an investigation to develop probabilistic composite micromechanics are summarized below.

1. A computational simulation procedure has been developed for probabilistic composite micromechanics by combining composite mechanics and ply substructuring, with probabilistic concepts and Monte Carlo simulation.

2. Anticipated scatter in constituent properties and fabrication processes (primitive) variables is directly incorporated in probabilistic composite micromechanics.

3. All the ply mechanical and thermal properties (moduli, thermal expansion coefficients and strengths) are evaluated simultaneously. This corresponds to using the same laminate for determining all the properties.

4. The scatter range and mean in each of the ply properties is presented in terms of frequency and cumulative distribution function.

5. Comparisons of deterministic values with respective probabilistic means provide insight into the inherent probabilistic nature of the ply behavior, anticipated scatter in measured properties, and probable type of fracture.

6. Ply fracture is a complex sequence of events and is not generally controlled by the weakest subply and ply fracture stresses will generally exhibit wide scatter.

7. Probabilistic composite micromechanics provide extensive information which formally relates ply phenomenological behavior to a large number of complex and interacting uncertainties at the micromechanics level.

REFERENCES

1. Chamis, C.C., "Mechanics of Composite Materials: Past, Present, and Future," NASA TM-100793, 1988.
2. Murthy, P.L.N. and Chamis, C.C., "Integrated Composites Analyzer (ICAN): User's and Programmer's Manual," NASA TP-2515, 1986.

3. Sobol, I.M., The Monte Carlo Method, (Translated by R. Messer, J. Stone, and P. Fortini) The University of Chicago Press, Chicago, 1974.
4. Ryan, T.A., Jr., "MINITAB," The Pennsylvania State University Computation Center, Jan. 15, 1981.
5. Stock, T.A., "Probabilistic Composite Mechanics," Proposed NASA Contractor Report.

TABLE I. - INPUT DATA FOR SAMPLING

Input	Deterministic	Probabilistic	
	Case 1	Case 2	Case 3
Theta, deg	0.0	-----	-----
μ	-----	0.0	0.0
σ	-----	5.0	10.0
FVR	0.50	-----	-----
μ	-----	0.5	0.5
σ	-----	0.1	0.2
VVR	0.01	-----	-----
λ	-----	0.3	0.3
k	-----	0.03	0.05
E _{f11} , ksi	31 000	-----	-----
μ	-----	31 000	31 000
σ	-----	1 500	3 000
E _{f22} , ksi	2 000	-----	-----
μ	-----	2 000	2 000
σ	-----	100	
G _{f12} , ksi	2 000	-----	-----
μ	-----	2 000	2 000
σ	-----	100	200
G _{f23} , ksi	1 000	-----	-----
μ	-----	1 000	1 000
σ	-----	50	100
ν _{f12}	0.2	-----	-----
μ	-----	0.2	0.2
σ	-----	0	0
α _{f11} , ppm/°F	0.2	-----	-----
μ	-----	0.2	0.2
σ	-----	0	0
α _{f22} , ppm/°F	5.6	-----	-----
μ	-----	5.6	5.6
σ	-----	0	0
S _{ft} , ksi	400	-----	-----
β	-----	400	400
α	-----	20	10
S _{fC} , ksi	400	-----	-----
β	-----	400	400
α	-----	20	10
E _m , ksi	500	-----	-----
μ	-----	500	500
σ	-----	25	50
ν _m	-----	0.35	-----
μ	-----	0.35	0.35
σ	-----	0	0
α _m , ppm/°F	36	-----	-----
μ	-----	36	36
σ	-----	0	0
S _{mT} , ksi	15	-----	-----
β	-----	15	15
σ	-----	20	10
S _{mc} , ksi	35	-----	-----
β	-----	35	35
α	-----	20	10
S _{mS} , ksi	13	-----	-----
β	-----	13	13
α	-----	20	10

ORIGINAL PART IS
OF POOR QUALITY

TABLE II. - CASE I RESULTS

Property	Value
$E_{\theta 11}$	15.8 mpsi
$E_{\theta 22}$	1.06 mpsi
$G_{\theta 12}$	0.52 mpsi
$\nu_{\theta 12}$	0.275
$\nu_{\theta 21}$	0.018
$\alpha_{\theta 11}$	0.775 $\mu\text{m/in/in}/^{\circ}\text{F}$
$\alpha_{\theta 22}$	0.181 $\mu\text{m/in/in}/^{\circ}\text{F}$
$\alpha_{\theta 12}$	0.000 $\mu\text{m/in/in}/^{\circ}\text{F}$
$S_{\theta 11T}$	203 ksi
$S_{\theta 11C}$	165 ksi
$S_{\theta 22T}$	11.74 ksi
$S_{\theta 22C}$	27.41 ksi
$S_{\theta 12S}$	10.01 ksi

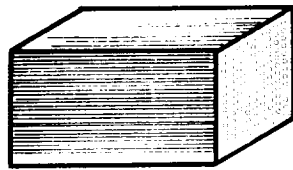

(A) ORTHOTROPIC PLY.

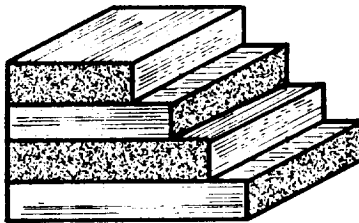

(B) LAMINATE.

FIGURE 1. - CONVENTIONAL MODEL.

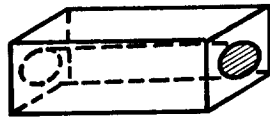

(A) SUBPLY.

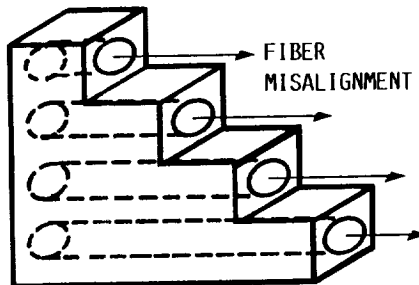

(B) PLY.

FIGURE 2. - SUBSTRUCTURE MODEL.

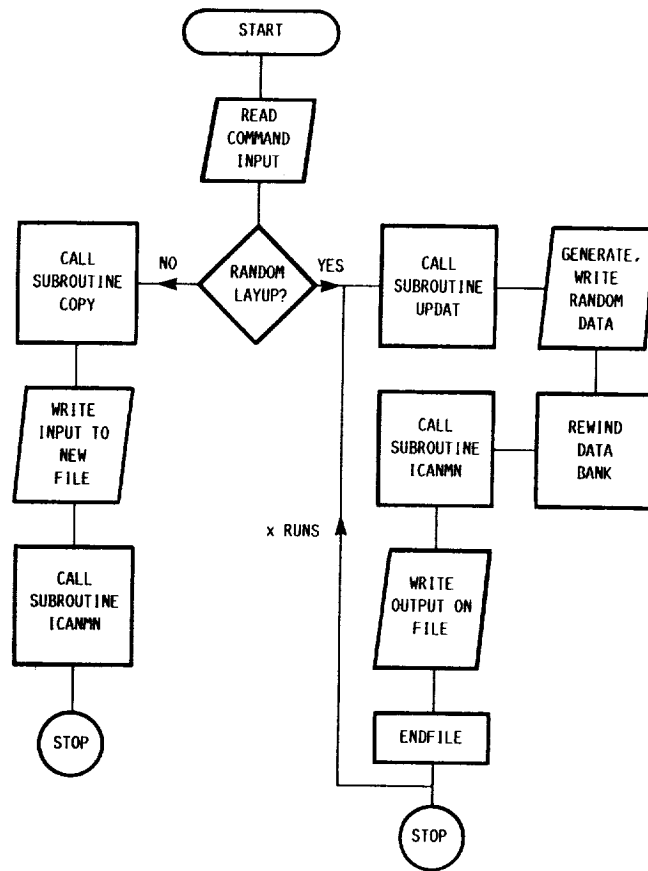

(A) MONTE CARLO SIMULATION OF UNCERTAINTIES IN PRIMITIVE VARIABLES.

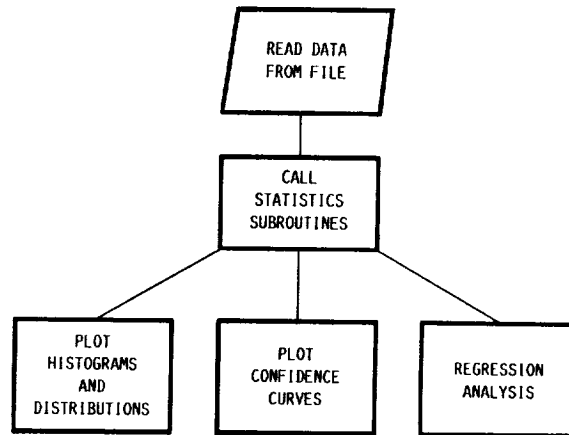

(B) QUANTIFICATION OF PLY PROPERTY UNCERTAINTIES.

FIGURE 3. - PROBABILISTIC COMPOSITE MICROMECHANICS COMPUTATIONAL PROCEDURE LOGIC DIAGRAMS.

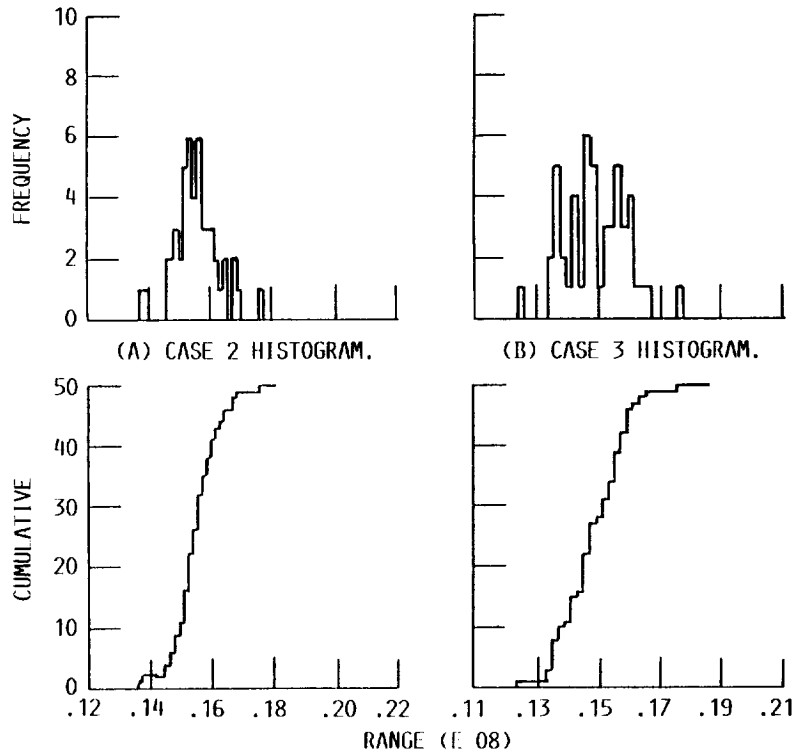

(C) CASE 2 DISTRIBUTION. (D) CASE 3 DISTRIBUTION.

FIGURE 4. - SAMPLING RESULTS FOR LONGITUDINAL MODULUS (E_{l11}).

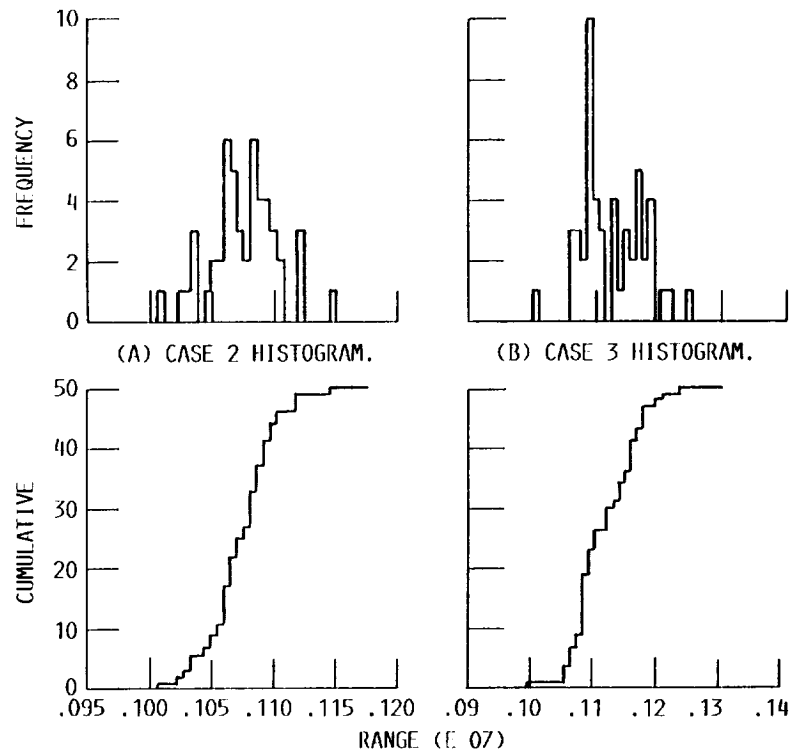

(C) CASE 2 DISTRIBUTION. (D) CASE 3 DISTRIBUTION.

FIGURE 5. - SAMPLING RESULTS FOR TRANSVERSE MODULUS (E_{t22}).

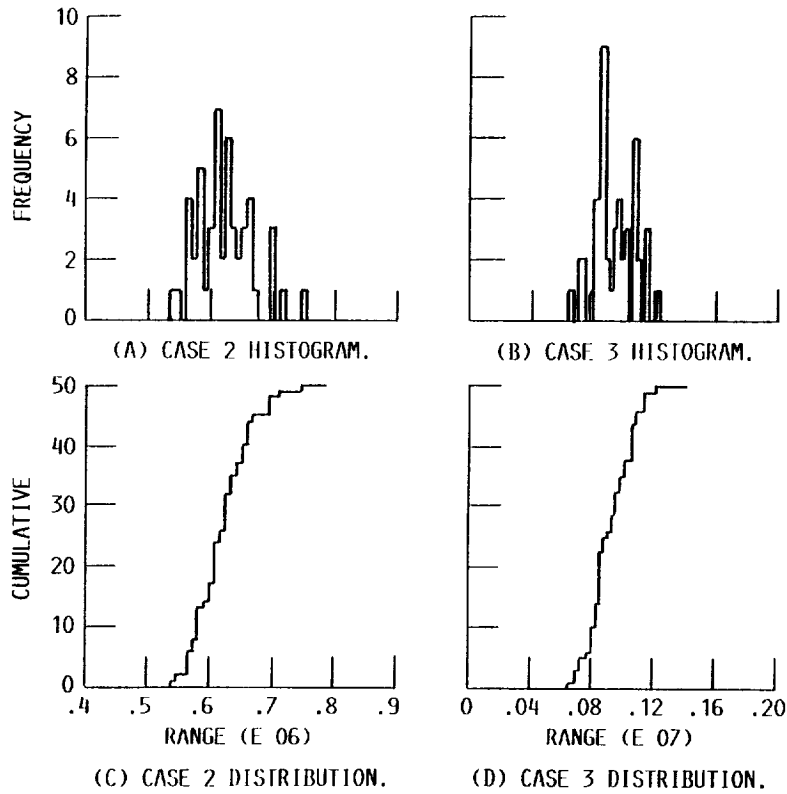

FIGURE 6. - SAMPLING RESULTS FOR IN-PLANE SHEAR MODULUS (G_{l12}).

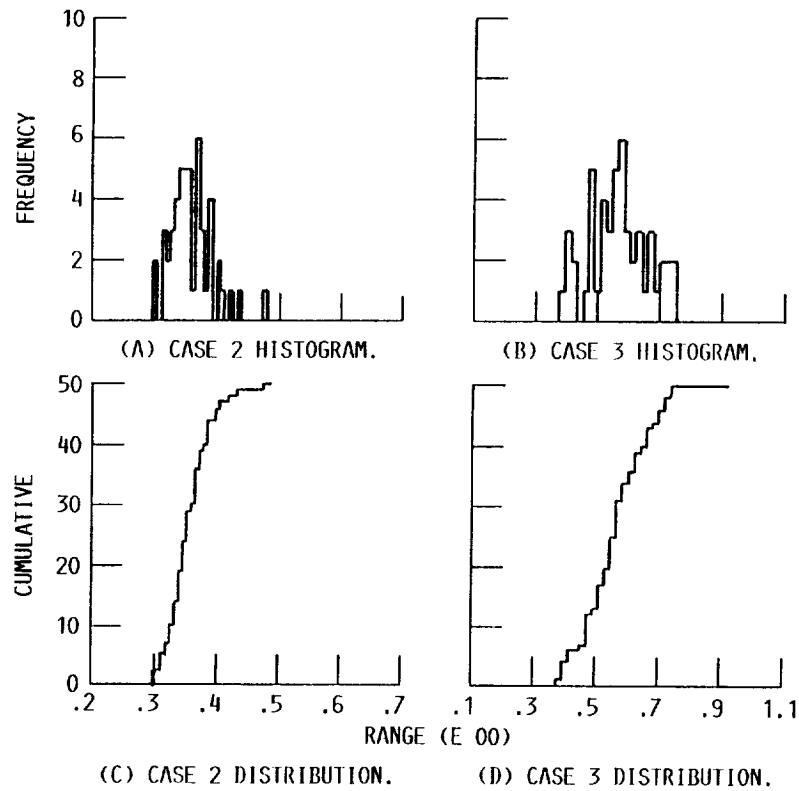

FIGURE 7. - SAMPLING RESULTS FOR POISSON RATIO (MAJOR ν_{l12}).

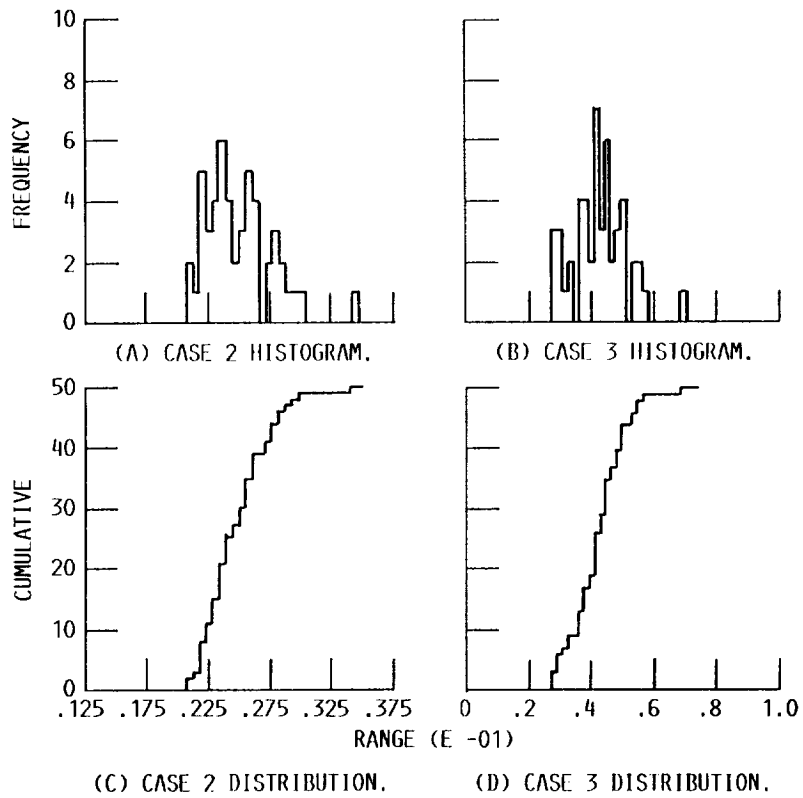

FIGURE 8. - SAMPLING RESULTS FOR POISSON RATIO (MINOR- ν_{21}).

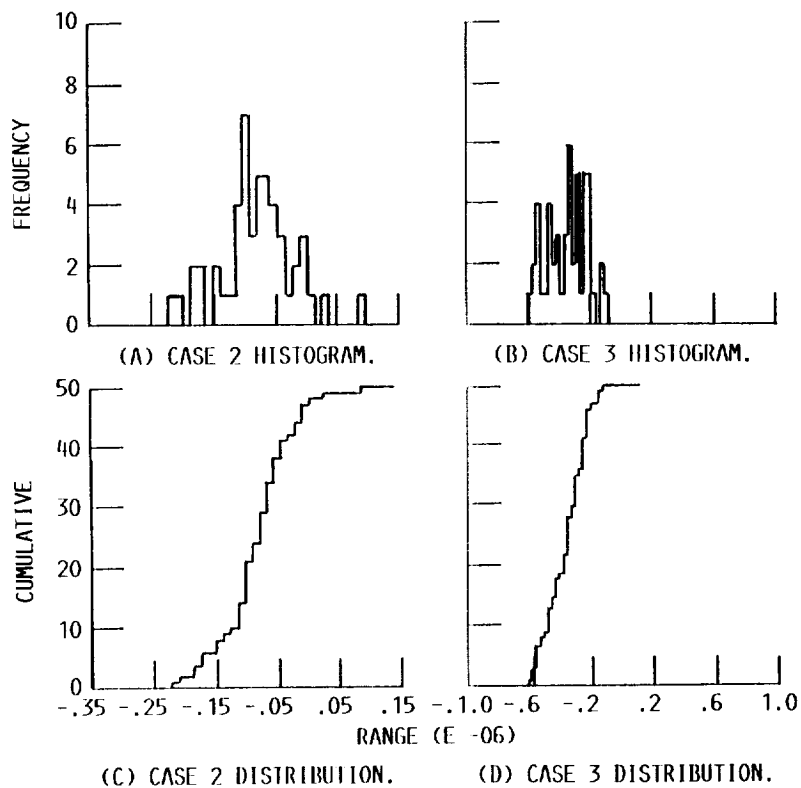

FIGURE 9. - SAMPLING RESULTS FOR LONGITUDINAL THERMAL EXPANSION (α_{211}).

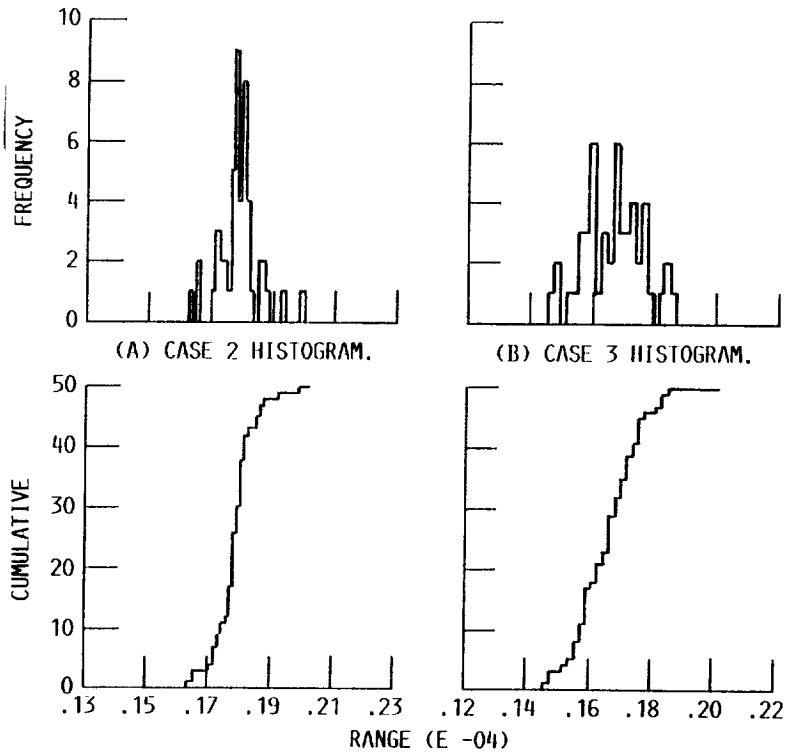

FIGURE 10. - SAMPLING RESULTS FOR TRANSVERSE THERMAL EXPANSION (α_{l22}).

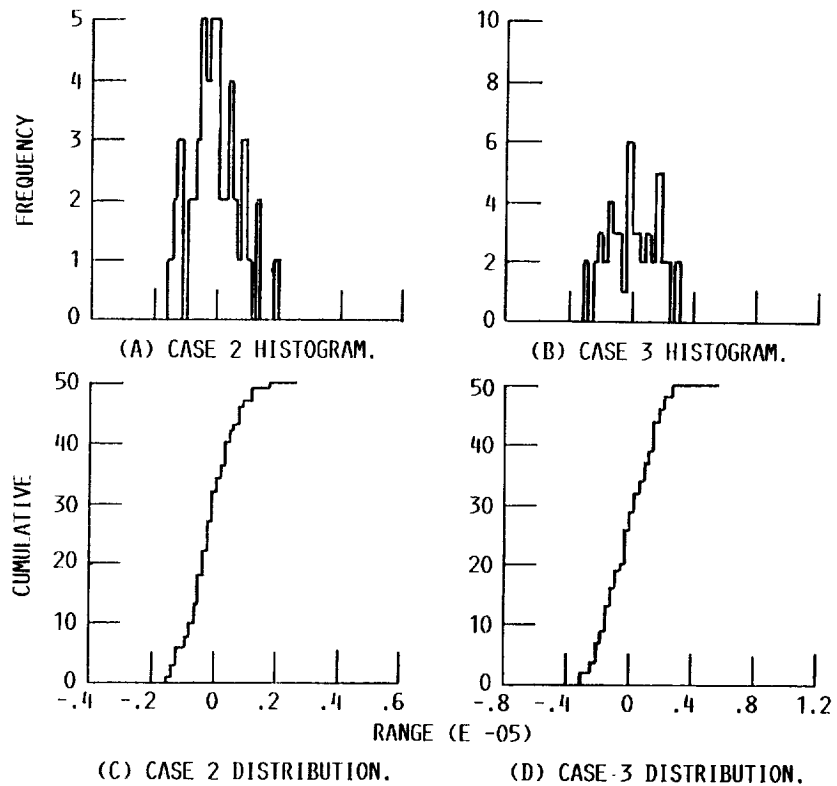

FIGURE 11. - SAMPLING RESULTS FOR THERMAL EXPANSION COUPLING (α_{l12}).

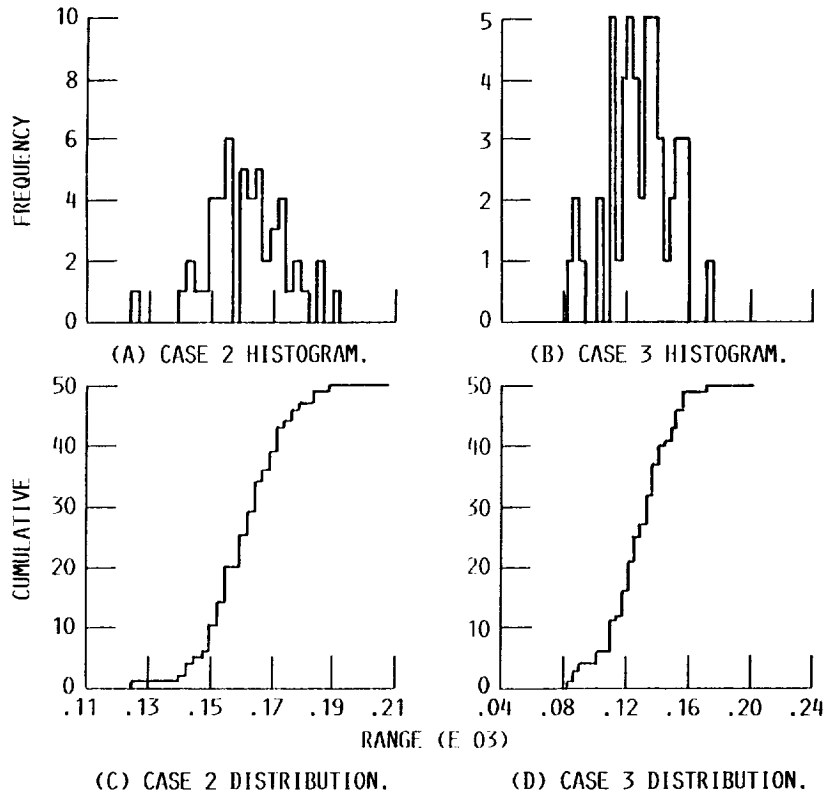

FIGURE 12. - SAMPLING RESULTS FOR LONGITUDINAL TENSILE STRENGTH (S_{l11T}).

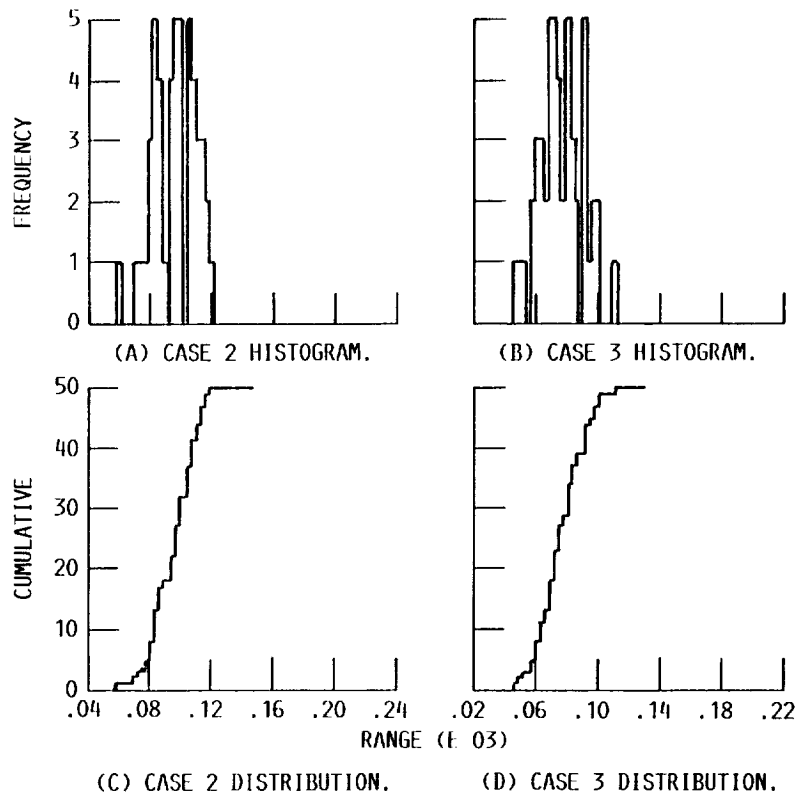

FIGURE 13. - SAMPLING RESULTS FOR LONGITUDINAL COMPRESSIVE STRENGTH (S_{l11C}).

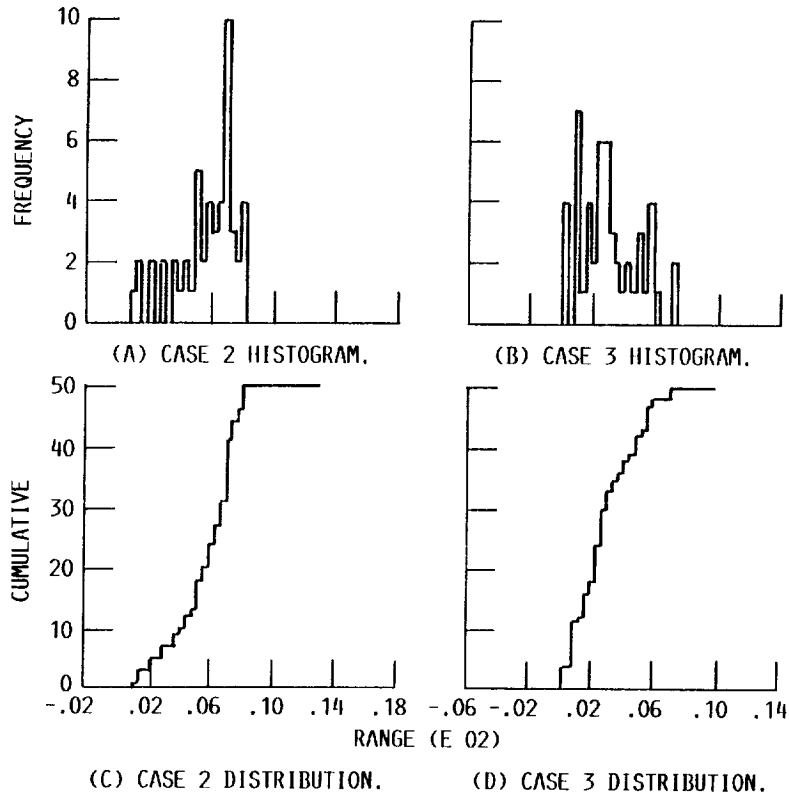

FIGURE 14. - SAMPLING RESULTS FOR TRANSVERSE TENSILE STRENGTH (S_{l22T}).

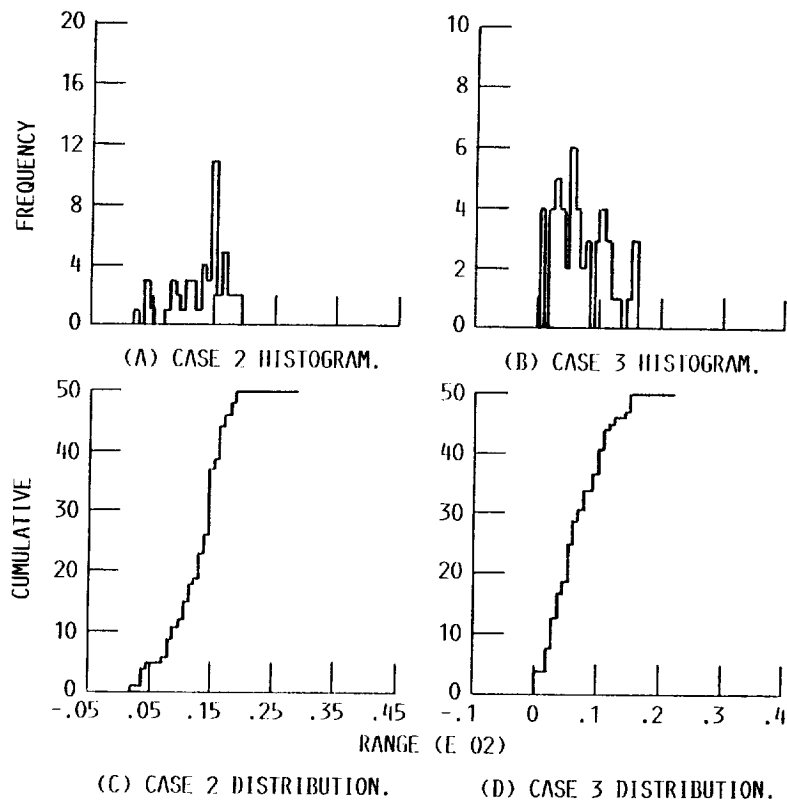

FIGURE 15. - SAMPLING RESULTS FOR TRANSVERSE COMPRESSIVE STRENGTH (S_{l22c}).

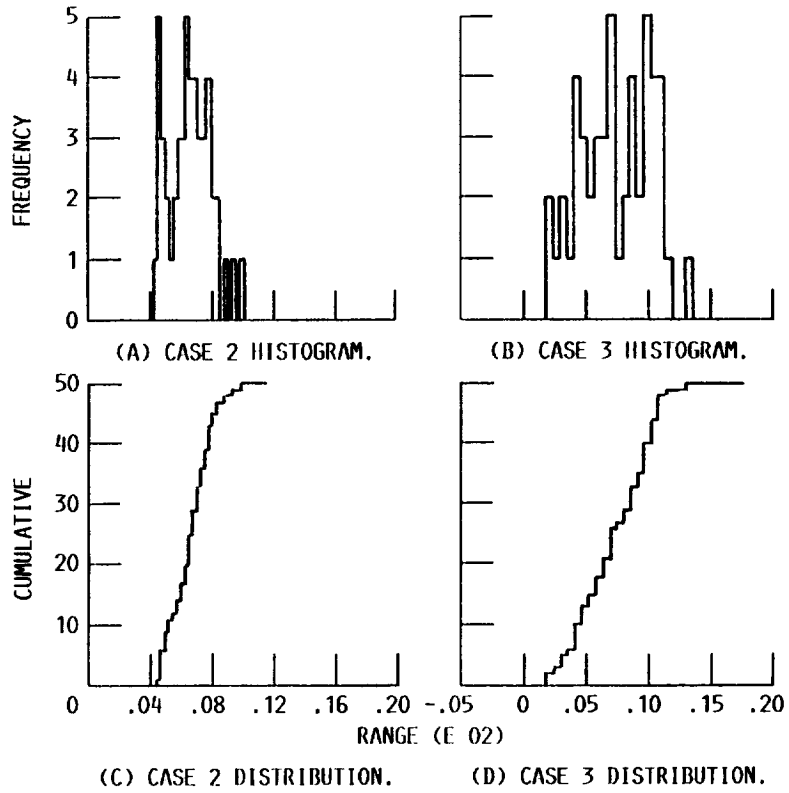

FIGURE 16. - SAMPLING RESULTS FOR IN-PLANE SHEAR STRENGTH (S_{112S}).

1. Report No. NASA TM-101366		2. Government Accession No.		3. Recipient's Catalog No.	
4. Title and Subtitle A Probabilistic Approach to Composite Micromechanics				5. Report Date	
				6. Performing Organization Code	
7. Author(s) T.A. Stock, P.X. Bellini, P.L.N. Murthy, and C.C. Chamis				8. Performing Organization Report No. E-4405	
				10. Work Unit No. 505-63-11	
9. Performing Organization Name and Address National Aeronautics and Space Administration Lewis Research Center Cleveland, Ohio 44135-3191				11. Contract or Grant No.	
				13. Type of Report and Period Covered Technical Memorandum	
12. Sponsoring Agency Name and Address National Aeronautics and Space Administration Washington, D.C. 20546-0001				14. Sponsoring Agency Code	
15. Supplementary Notes Presented at the 29th Structures, Structural Dynamics and Materials Conference cosponsored by the AIAA, ASME, ASCE, AHS, and ACS, Williamsburg, Virginia, April 18-20, 1988. T.A. Stock, P.X. Bellini, and P.L.N. Murthy, Cleveland State University, Cleveland, Ohio 44115 (T.A. Stock, presently at Wright-Patterson Air Force Base, Dayton, Ohio 45433); C.C. Chamis, NASA Lewis Research Center.					
16. Abstract A probabilistic approach to composite micromechanics is developed that simulates uncertainties in unidirectional fiber composite properties. These methods are in the form of computational procedures using Monte Carlo simulation. The variables for which uncertainties are accounted include constituent and void volume ratios, constituent elastic properties and strengths, and fiber misalignment (primitive variables). A graphite/epoxy unidirectional composite (ply) is studied to incorporate fiber composite material properties uncertainties at the micro level. Probabilistic composite micromechanics provides extensive information which formally relates ply phenomenological behavior to a large number of complex and interacting uncertainties at the constituents level.					
17. Key Words (Suggested by Author(s)) Fiber composites; Probability; Histograms; Cumulative distribution; Monte Carlo; Ply properties; Fiber properties; Matrix properties moduli; Strengths; Fracture process; Computational simulation; Scatter; Means			18. Distribution Statement Unclassified - Unlimited Subject Category 24		
19. Security Classif. (of this report) Unclassified		20. Security Classif. (of this page) Unclassified		21. No of pages 20	22. Price* A03