

173841

NASA CASE NO. MFS-28183-1PRINT FIGURE 3NOTICE

The invention disclosed in this document resulted from research in aeronautical and space activities performed under programs of the National Aeronautics and Space Administration. The invention is owned by NASA and is, therefore, available for licensing in accordance with the NASA Patent Licensing Regulation (14 Code of Federal Regulations 1245.2).

To encourage commercial utilization of NASA-owned inventions, it is NASA policy to grant licenses to commercial concerns. Although NASA encourages nonexclusive licensing to promote competition and achieve the widest possible utilization, NASA will consider the granting of a limited exclusive license, pursuant to the NASA Patent Licensing Regulations, when such a license will provide the necessary incentive to the licensee to achieve early practical application of the invention.

Address inquiries and all applications for license for this invention to NASA Patent Counsel, Marshall Space Flight Center, Mail Code CCO1, Huntsville, AL 35812. Approved NASA forms for application for nonexclusive or exclusive license are available from the above address.

(NASA-Case-MFS-28183-1) A REFERENCE
STANDARD FOR ELLIPTICAL REFLECTION
DISTRIBUTION FUNCTION AND ELLIPTICAL
TRANSMISSION DISTRIBUTION FUNCTION
MEASUREMENT Patent Application (NASA)

N89-13253

EFC

Unclas

15 p G3/74 0173841

TECHNICAL ABSTRACT

A REFERENCE STANDARD FOR BI-DIRECTIONAL REFLECTION
DISTRIBUTION FUNCTION AND BI-DIRECTIONAL TRANSMISSION
DISTRIBUTION FUNCTION MEASUREMENTS

This invention relates generally to Lambertian reflectors and refractors and more particularly to reference standards for bi-directional reflection and refractive distribution function measurements.

A Lambertian reference standard is constructed by affixing an even layer of like-sized monodisperse spheres in a thin layer of bonding agent on a flat surface of a plate. In the instance where a reflective standard is constructed, the plate and spheres are coated, as by vapor deposition, with a reflective material, such as gold or silver. In the instance where a refractive standard is constructed, the spheres are of a transparent material, such as glass, and have an irregular surface created by a process such as acid etching. The refractive embodiment includes a bonding agent and plate having refractive indexes which matches that of the spheres.

The novelty of this invention particularly lies in constructing these reference standards with monodisperse spheres, and in the case of a refractive standard, matching the refractive index of the plate and bonding agent to that of the spheres.

Inventor:	William K. Witherow
Employer:	NASA/MSFC
Serial Number:	244,367
Date Filed:	September 15, 1988

ORIGINAL PAGE IS
OF POOR QUALITY

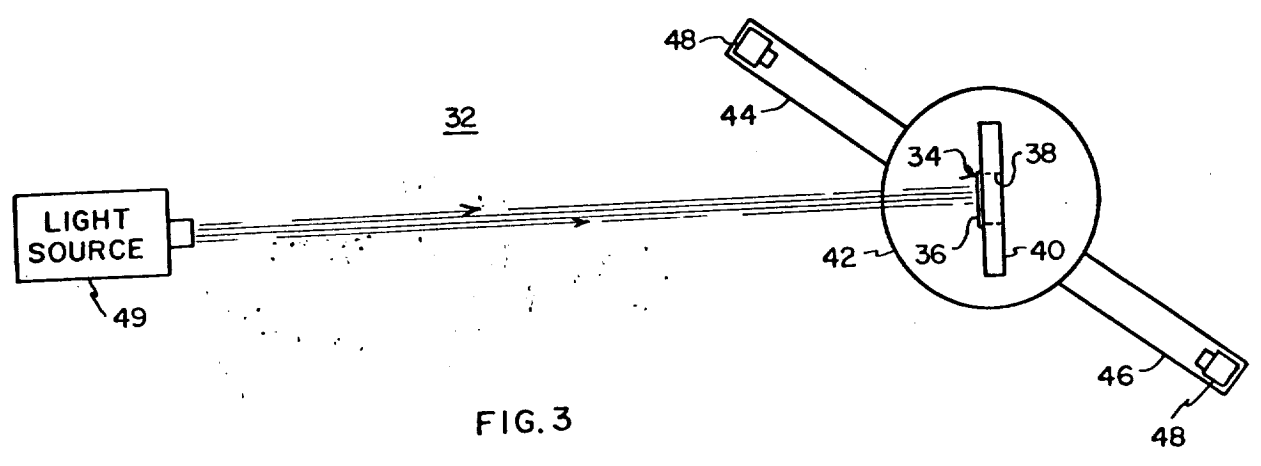
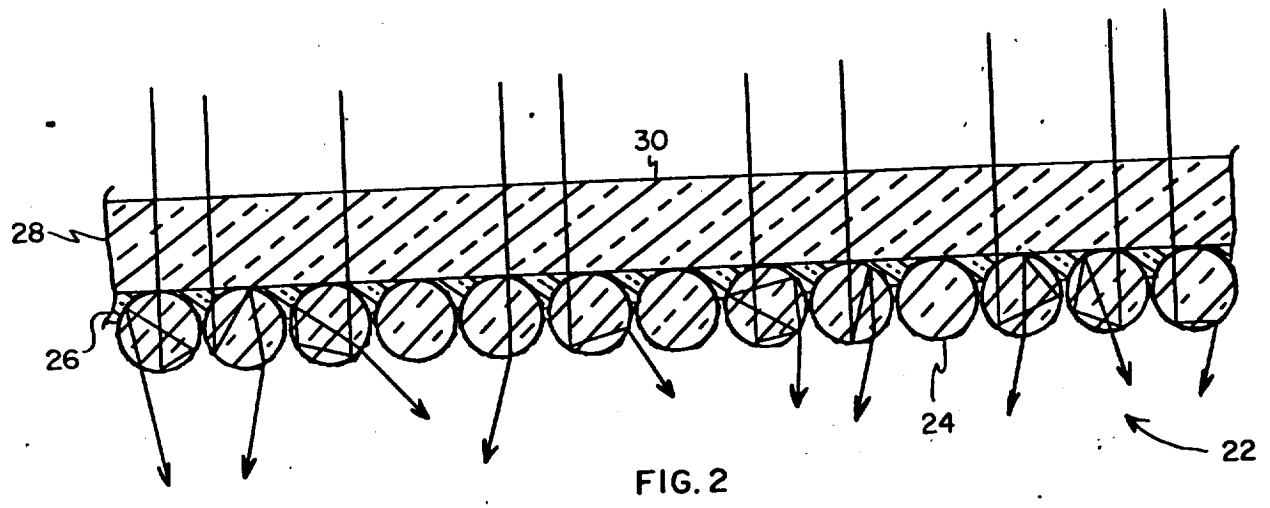
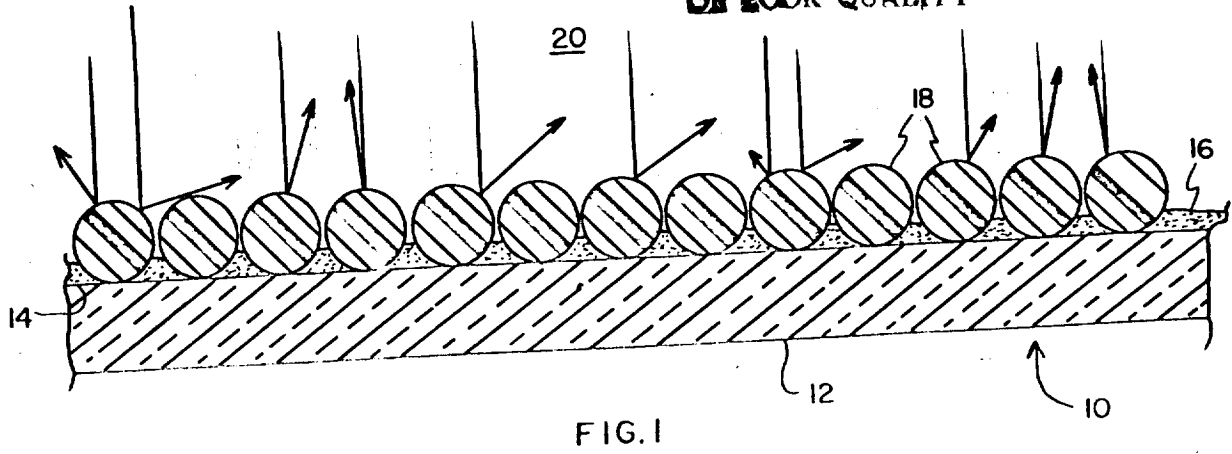

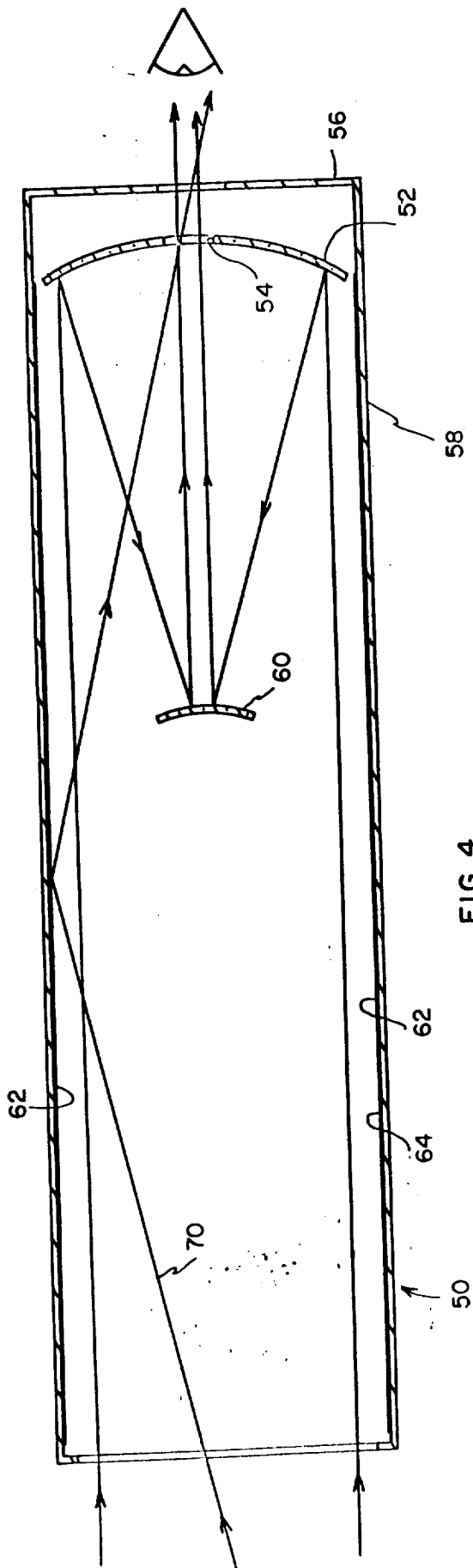

FIG. 4

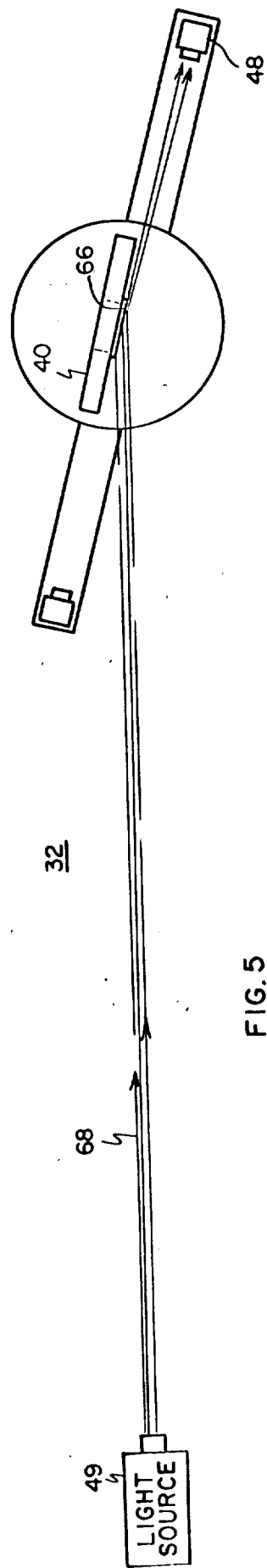

FIG. 5

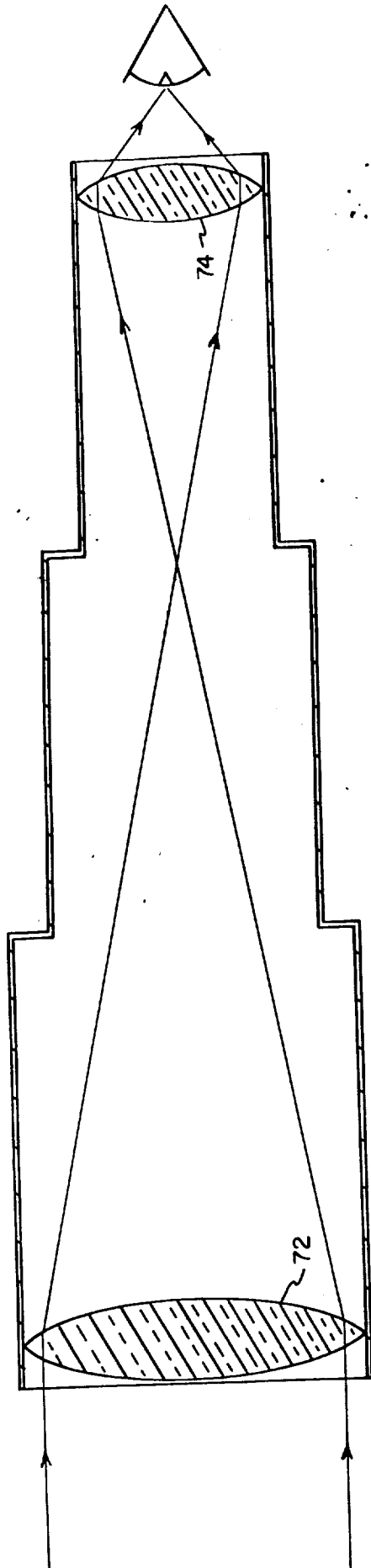

FIG. 6

71

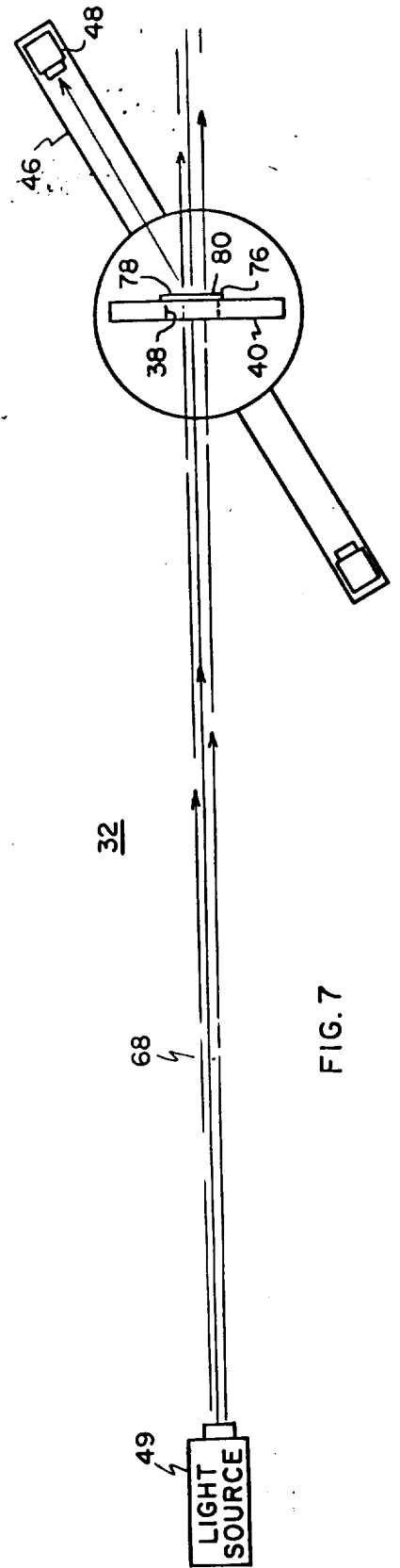

FIG. 7

A REFERENCE STANDARD FOR BI-DIRECTIONAL REFLECTION
DISTRIBUTION FUNCTION AND BI-DIRECTIONAL TRANSMISSION
DISTRIBUTION FUNCTION MEASUREMENTS

Origin of the Invention

5 The invention described herein was made by employees of the United States Government and may be manufactured and used by or for the Government for Government purposes without the payment of any royalties thereon or therefor.

10 Technical Field

 This invention relates generally to Lambertian reference standards used in bi-directional reflectance and transmission distribution function (BRDF and BTDF) comparisons and calibrations, and more particularly to
15 a standard wherein an evenly packed layer of similarly sized monodisperse spheres are fixed on a planar surface of a flat plate.

Background of the Invention

 In the field of optics relating to the visible and
20 long-wavelength (infrared) spectrums, it is necessary to evaluate stray light rejection systems, laser back scatter, reflective characteristics of materials, and coated or polished surfaces. This is generally done
25 by shining an incident beam of light on a coating or surface being evaluated and measuring light which is scattered or reflected therefrom. These measurements of reflected or scattered light are known as
30 bi-directional reflection distribution function (BRDF) when obtained from a reflective surface, and bi-directional transmission distribution function (BTDF) when obtained from transparent or translucent materials. BRDF/BTDF is mathematically defined as being:

$$f_r(\theta_i, \phi_i; \theta_r, \phi_r) = \frac{dL_r(\theta_i, \phi_i; \theta_r, \phi_r; E_i)}{dE_i(\theta_i, \phi_i)}$$

where θ and ϕ are angles in spherical coordinates, i and r refer to incident and reflected quantities, respectively, L_r is reflected radiance, and E_i is incident irradiance. This formula is a solid geometric representation of a ratio of incident light to reflected light and is helpful in determining characteristics of light reflective/transmissive surfaces.

In practice, measuring scattered light is done by mounting a sample of the surface being evaluated on a rotating turntable. This turntable is angularly positionable from 0° to 90° in any plane with respect to an incident beam of light directed onto the sample. A sensitive photovoltaic detector is mounted a fixed distance from the sample on an arm that can be rotated in a horizontal plane about the sample. The horizontal plane includes the incident beam. The detector records reflected light levels at points of interest and converts this reflected or scattered light to voltage levels, which are recorded. Next, the sample surface is removed from the turntable, and a reference standard is similarly mounted on the turntable, with a photovoltaic detector being positioned to measure scattered light at the identical points of interest that were measured from the sample. This reference standard is constructed to scatter a beam of light perpendicularly striking the reference sample uniformly and in an even distribution 360° around the point where the incident beam of light impinges on the standard, and in an even distribution from 0° to 90° with respect to the beam. Additionally, the reference standard must absorb as little as possible of the incident beam of light. This type of reflector is known as a Lambertian reflector, and when compared as described to a surface being evaluated for light scattering properties, establishes a baseline reference for scattered light. Accordingly, and since the aforementioned formula defining BRDF/BTDF is cumbersome to use and difficult to implement when there are numerous points of interest at which it is desirable to

know the degree of light scattered thereto, measurements of light scattered by the sample and the reference standard may be compared to find the BRDF/BTDF of a sample by using the simplified formula:

5
$$BRDF_{UNK} = BRDF_{REF} \left(\frac{V_{UNK}}{V_{REF}} \right)$$

where V_{UNK} and V_{REF} are the photovoltaic voltage levels from the surface to be evaluated (V_{UNK}) and the reference standard (V_{REF}), with $BRDF_{REF}$ being approximately 0.318, a constant representative of a Lambertian reflector or transmitter.

10 Problems with these BRDF comparative methods are that, to date, a suitable reference standard has yet to be found. Some of the materials used in attempts to duplicate a Lambertian reflector are magnesium oxide (MgO), halon, sintered bronze, and flowers of sulfur. 15 These materials are deposited, typically by vapor deposition, on a planar surface which is then used as a reference as described. However, MgO and halon possess a physical structure which is too fine to behave as a Lambertian reflector in the long wavelength 20 infrared spectrum, while flowers of sulfur are not sufficiently durable to survive handling. Sintered bronze only approximates a Lambertian reflector because of surface irregularities which scatter light in a non-uniform manner. This has led researchers to use a fine 25 grade (600 grit) sandpaper which is coated with gold to approximate a Lambertian reflector. Problems with using gold-plated sandpaper are that, like sintered bronze, gold-plated sandpaper has irregularities which scatter 30 light in a non-uniform manner. Further, gold-plated sandpaper is not sufficiently durable and degrades over time. Additionally, gold-plated sandpaper is not consistent enough between different sheets to be used as a reference standard. Still further, it was 35 discovered that gold-plated sandpaper is a fairly good approximation of a Lambertian surface when the angle of

incidence of the beam of light is small, but not when the angle of incidence is as large as 60° . For more information on the BRDF of gold-plated sandpaper, see "Applied Optics," Vol. 20, No. 15, August 1, 1981, Bi-directional Reflectance Distribution Function of Gold-plated Sandpaper by T.W. Stuhlinger, E.L. Dereniak, and F.O. Bartell.

Accordingly, it is an object of this invention to provide a BRDF reference standard which is durable and which more closely approximates a Lambertian reflector than any of the substances priorly used.

Summary of the Invention

In accordance with this invention, a Lambertian reference standard for uniformly scattering light is constructed having a plate with a planar surface, with a layer of similarly sized spheres disposed thereupon.

Brief Description of the Drawings

Fig. 1 is a sectional view of a Lambertian reflector of the present invention.

Fig. 2 is a sectional view of a Lambertian transmitter of the present invention.

Fig. 3 is a diagrammatic illustration of a light scattering apparatus.

Fig. 4 is a diagrammatic illustration of a Cassegrainian reflecting telescope.

Fig. 5 is a diagrammatic view of the light scattering apparatus as generally used to evaluate light absorbing coatings.

Fig. 6 is a diagrammatic view of a refracting telescope.

Fig. 7 is a diagrammatic view of the light scattering apparatus as generally used to evaluate light transmissive coatings.

Description of the Preferred Embodiment

A reference standard for bi-directional reflectance

and transmittance distribution function (BRDF and BTDF) measurements consists of similarly sized monodispersed spheres disposed on a planar surface and appropriately treated to behave either as a Lambertian reflector or a Lambertian transmitter.

Referring to Fig. 1, a BRDF reference standard 10 is constructed as shown of a plate 12 having a planar surface 14. Surface 14 is evenly coated with a layer 16 of bonding agent, such as an epoxy resin, and into this layer 16 is pressed an evenly packed layer of like-sized monodisperse spheres 18. Spheres 18 are constructed of material such as glass or latex and, depending on the wavelength of light to be studied, can range in size from 0.1 to 500 microns between different standards. Spheres 18 are coated, as by vapor deposition, with a highly reflective substance, such as gold or silver, to minimize light absorption by spheres 18.

When an incident beam of light 20 is directed onto reference standard 10 (Fig. 1), individual beams of light are reflected in directions depending on where the light strikes a discrete coated sphere 18. Thus, light impinging at a point on a sphere which is closest to a light source is generally reflected back toward the source, while light striking sides of a sphere 18 may be directed almost 90° with respect to beam of light 20. This evenly distributes the beam of light 360° around the point where the beam impinges on the sample and from 0° to 90° with respect to the beam. Light which is thusly diffused is used as a baseline for comparing reflective characteristics of surfaces to be evaluated thereto.

In the instance where a reference standard is to be used in bi-directional transmission distribution function (BTDF) measurements (Fig. 2), a standard 22 is constructed having glass spheres 24 constructed with a slightly roughened surface. This is achieved as by acid etching, with spheres 24 being evenly pressed in an even

layer into a layer 26 of optical cement selected to have a refractive index similar to that of spheres 24 and a transparent glass plate 28. Optical cement is used to reduce refraction of light as it passes first
5 through glass plate 28, then through layer 26 of optical cement, and finally through spheres 24.

In this case, the incident beam of light is directed onto side 30 of standard 22, with the light passing through transparent plate 28 as described and
10 into spheres 24. Because of the roughened surface on spheres 24, the individual beams of light are then reflected within discrete spheres until encountering an irregularity which is generally perpendicular to the direction of the reflected beam. When this occurs, the
15 beam exits the sphere. Very fine irregularities on surfaces of spheres 24 are more associated with Lambertian surfaces, while coarse irregularities tend to scatter light in a non-uniform manner. As with the aforementioned standard 10, light passing through
20 standard 22 is evenly diffused 360° around the point where beam 20 passes therethrough and from 0° to 90° with respect to beam 20. This also establishes a baseline against which light transmissive coatings may be compared.

25 In use, and referring to Fig. 3, a light scattering apparatus 32 is diagrammatically shown which is typically used to measure scattered light. A sample 34 having a surface 36 to be evaluated is mounted on a rotating turntable 40, with this turntable in turn
30 being mounted to an angularly positionable gimbal 42. Turntable 40 is rotated at a predetermined speed to average out effects of speckle. A pair of detector arms 44 and 46 are mounted to be rotated about gimbal 42 and are used to mount photovoltaic detectors 48 thereupon.
35 These photovoltaic detectors convert light reflected from light source 49 to voltage levels, with these voltage levels obtained from the sample being compared to voltage levels obtained by a reference standard

similarly positioned on turntable 40.

One illustration of this procedure is shown in Fig. 4 and, by way of example, diagrammatically shows a Cassegrainian reflecting telescope 50. In this type of telescope, a concave primary mirror 52 having a central viewing aperture 54 is mounted at one end 56 of a housing 58. A secondary convex mirror 60 is mounted to reflect light from primary mirror 52 through aperture 54. As the clarity and resolution of the viewed image is largely dependent on the precision of mirrors 52 and 60, and to the extent that unwanted light 70 can be prevented from reaching mirrors 52 and 60, it is crucial that factors such as these be accurately evaluated. In the instance where a light absorbing coating 62 on interior wall 64 of telescope housing 58 is to be evaluated, a sample 66 of coating is deposited on a planar surface and mounted on turntable 40 of light scattering apparatus 32. An incident beam of light 68 from light source 49 is directed onto sample 66 in a similar angular relation to the incident unwanted light 70 (Fig. 4) entering telescope 50 and impinging on coating 62, with detector 48 being positioned where aperture 54 would be. The voltage level is recorded, and for purposes of illustration, it is assumed that this voltage level is 0.05 mv. Next, reference standard 10 is mounted on turntable 40, and beam 68 is directed thereupon in the same angular relation as the unwanted light 70 in telescope 50. Detector 48 is again positioned where aperture 54 would be, and for purposes of illustration, it is assumed that it records 0.50 mv. In accordance with the formula earlier set forth:

$$BRDF_{UNK} = BRDF_{REF} (V_{UNK}) / (V_{REF})$$

or

$$\text{BRDF}_{\text{UNK}} = 0.318 \quad (0.05/50).$$

5 It is seen that the light absorbing sample 66 has a
BRDF value of 0.000318, meaning that sample 66 is a
good medium for absorbing unwanted reflected light.

10 When apparatus 32 is to be used to evaluate BTDF
(bi-directional transmission distribution function) of
a transparent sample, such as when compound lenses are
coated with a light transmitting coating, such as zinc
selenide, operation is as follows. By way of example,
15 Fig. 6 diagrammatically illustrates a refractive
telescope 71. Telescope 71 is constructed having
compound lenses 72 and 74, which refract light entering
objective lens 72 to focus it on eyepiece lens 74. In
20 this case, the clarity of the viewed image is dependent
on the quality of lenses 72 and 74 and the degree they
accurately refract the available light to the viewer.
Obviously, it is crucial that the coatings on lenses
72 and 74, such as the aforementioned zinc selenide,
25 accurately transmits this light with as little
scattering as possible.

To evaluate lens coatings of the refractive
telescope shown in Fig. 6, a transparent sample plate
76 (Fig. 7) is constructed having the light
30 transmissive coating 78 deposited on a surface 80,
which is furthest away from source 49 of incident
light 68. This sample is mounted over a window 38 in
turntable 40. Detector 48 is positioned on arm 46,
which in turn is positioned to allow detector 48 to
35 measure light scattered in planes other than the focal
plane of incident light from light source 49. This
allows researchers to determine the degree of light
scattered by coating 78 by comparing the voltage levels
produced by sample 76 to the voltage levels obtained
40 from the Lambertian refractor priorly described. As
an example, it is assumed that sample 76 produces a

voltage level of 0.02 mv., while, as stated, reference standard 22 (Fig. 2) produces a voltage level of 50 mv. By using the formula:

$$BTDF_{UNK} = BTDF_{REF} (V_{UNK}/V_{REF})$$

5 which becomes

$$BTDF_{UNK} = 0.318 (0.02/50)$$

meaning that the $BTDF_{UNK}$ is 0.0001272. Thus, it is seen that coating 78 is a good light transmitting coating which results in little scattering.

10 In addition to the aforementioned uses of the Lambertian reflector 10 and refractor 22 in evaluating surfaces, reflector 10 and refractor 22 may be used to calibrate BRDF/BTDF facilities. This would be done by simply mounting reflective reference standard 10 or
15 transmitting reference standard 22 in window 38 of turntable 40 (Fig. 3) and appropriately positioning one of detectors 48 at various points of interest around the reference standard. Detector 48 may then be
20 calibrated to provide a voltage level which is consistent with similar facilities elsewhere, thus bringing all such facilities into an aligned relation.

From the foregoing, it is apparent that the applicant has provided a Lambertian reflector and Lambertian refractor to be used as a reference standard
25 for comparative studies of materials to be evaluated and which can be used as a standard for calibrating BRDF/BTDF facilities. Further, this standard is both durable and long-lived and can be constructed with little variation between discrete standards.

A REFERENCE STANDARD FOR BI-DIRECTIONAL REFLECTION
DISTRIBUTION FUNCTION AND BI-DIRECTIONAL TRANSMISSION
DISTRIBUTION FUNCTION MEASUREMENTS

Abstract of the Disclosure

5 A Lambertian reference standard (10) for uniformly
scattering a beam of light is constructed of a plate
(12) having a planar surface (14) with a layer (16) of
glue disposed on the surface (14). An evenly packed
layer of monodisperse spheres (18) is set in the layer
10 (16), and when the standard (10) is used for
bi-directional (BRDF) measurements, the spheres (18)
are coated with a layer of highly reflective substance,
such as gold or silver. When the standard (22) is used
for bi-directional transmittance distribution function
15 (BTDF) measurements, the spheres (24) are of a
transparent material and are provided with a roughened
surface, as by acid etching. In this case, the layer
(26) of glue is an optical cement, and the plate (28)
is of glass, with the spheres (24), the layer (26), and
20 the plate (28) all possessing a similar refractive
index.