

N89 - 13316

**Optical and Electrical Measurements on UV Sensitive
Photodiodes**

H. Lyall

NEI-IRD, Newcastle upon Tyne, England

A.D. Wilson

Barr & Stroud, Glasgow, Scotland

INTRODUCTION

A large portion of the work described in this paper was carried out for the European Space Agency (ESA) during a program to develop a multiband UV radiometer for use in a space simulation chamber. However some parts were carried out in conjunction with Newcastle Polytechnic involving students working towards a MSc. degree in Optoelectronics. Some information on the work for ESA has been published previously (Wilson and Lyall 1986a, b - henceforth WLa and WLb), and in this paper we are primarily concerned with further developments.

PRECEDING PAGE BLANK NOT FILMED

In general our work has been directed towards low frequency radiometric and instrumentation applications in a laboratory environment with particular emphasis on UV measurements. Although the detector might be remote from input amplifier and under widely differing conditions, the amplifiers and readout unit have been at ambient temperature. Most of our work has been with relatively large area devices in the region 5 to 25mm².

The silicon photodiodes we have studied include diffused junction photodiodes such as the EG&G UV215B and the Centronics OSD50-1 and inversion diodes such as the UDT-UV50, although we concentrated on the EG&G UV215B because its overall characteristics were the most appropriate for our applications. The other photodiodes we have studied are Schottky barrier gallium arsenide phosphide (GaAsP) G1126-02 and gallium phosphide (GaP) G1962 devices made by Hamamatsu.

OPTICAL MEASUREMENTS

Photodiode Responsivity

The measurement procedure has been described in detail elsewhere (WLa). Essentially it consisted of comparing the response to monochromatic light of a spatially underfilled

photodiode under test with the response of a calibrated photodiode. The results of these measurements are shown in Fig. 1. It can be seen that both GaAsP and GaP have a relatively poor responsivity in the UV but this is largely compensated for by their excellent electrical properties as discussed later. Of great interest from the optical point of view is the positions of the long wavelength cutoffs at about 650nm for GaAsP and 450nm for GaP which greatly ease the problems of optical filtering when used for UV measurements of solar or stellar sources. For example any type of silicon photodiode is unsatisfactory when used with UV transmitting glass absorption filters which invariably transmit well in the near infrared. By comparison, the GaAsP photodiodes only require a small correction due to a temperature dependent leakage at close to 700nm and this in turn could be eliminated by the use of GaP. Even when using interference filters the restricted spectral response offers considerable advantage in minimising blocking requirements. The response of the GaP has a peak at a similar wavelength to that of the potassium hydride cell previously used for astronomical photometry (Strong 1938), but with an improved short wavelength response.

The position of the long wavelength cutoff shifts to longer wavelengths with increasing temperature at a rate of about 0.2 nmK^{-1} for GaAsP and 0.3 nmK^{-1} for GaP.

UV Exposure Tests

Again the detailed measurement procedures have been described elsewhere (WLB) and consisted essentially of exposing the photodiodes to various doses of UV from a quartz enveloped mercury discharge lamp. The experimental region was flushed with dry nitrogen to inhibit ozone formation and the tests were usually carried out with the windows removed from the device package.

The basic pattern which emerges is that at very low levels ($10\mu\text{Wcm}^{-2}$) all the photodiodes were stable except for the OSD50-1. At levels of 2mW^{-2} there were changes of $>10\%$ for all of the silicon photodiodes over periods of 15 to 20 hours, although the UDT UV50 only showed a fall off in response for wavelengths below 255nm. All the silicon photodiodes tested degraded significantly ($>30\%$ at 200nm) under high levels (60mWcm^{-2} at 254nm) after exposure periods of 20 hours. Although early (pre 1981) GaAsP photodiodes had shown some instability, later devices showed no significant changes in responsivity at high levels. Tests on GaP showed a small ($<5\%$) enhancement in responsivity after 0.5 hours exposure to very high levels of UV (120mWcm^{-2}) but the measured response after 1 to 17 hours exposure was indistinguishable from the initial values.

For GaAsP and GaP photodiodes good results were only obtained consistently when the window was removed and the device operated with the nitrogen flushed atmosphere. Photodiodes tested in the sealed package supplied by the manufacturer usually exhibited a significant degree of deterioration.

Long Term Stability

Although apparently exhibiting good long term stability at the longer wave end of the visible and in the near infrared, silicon photodiodes have been known to show changes in responsivity in the UV. This can occur even when the photodiode is stored without being subjected to UV exposure (P.J. Key, National Physical Laboratory, personal communication). Fig. 2 shows results obtained with an EG&G UV215B photodiode which we have used for intercomparison purposes over a number of years. This photodiode has never been deliberately exposed to UV other than the very low levels ($<20\text{nW}$) used during calibration, but it can be seen that the UV enhancement has vanished.

We have not been able to carry out a detailed study of the long term stability of GaAsP photodiodes, however the multiband UV radiometer built for ESA using these devices

showed no discernible change from the original NPL calibration over a period of a year when checked against a freshly calibrated photodiode.

No information is yet available on the long term stability of GaP although one could perhaps be optimistic in view of its similarity to GaAsP in construction and general performance.

Comments on UV Stability

The problem with the deterioration in response of the UV215B has been discussed with EG&G (J. Melnyk-personal communication) and it appears that long term UV instability has been encountered on a number of occasions and was eventually traced to ionic contamination prior to oxidation of the top surface of the photodiode. Devices made by EG&G after 1985 (as determined by the date code on the package) should be free of this defect, however it may be a problem with older devices or those of a similar construction from other sources.

The deterioration in the performance of the Hamamatsu photodiodes when operated in their original, package could be due to the effects of ozone formation from any entrapped oxygen, or due to degradation of the other materials within the enclosure, for example conductive epoxy, leading to

contamination of optical surfaces. If the latter explanation is valid it may be more significant that we flushed the atmosphere around the test area than that we used dry nitrogen, but this has not been investigated. As a precaution we did take considerable care during the construction of the UV radiometers for ESA that none of the conductive epoxy used to cement the chips in place was exposed to UV.

MEASUREMENT OF ELECTRICAL CHARACTERISTICS

Experimental Procedures for Electrical Tests

Because we have found it difficult to extract the design information which we require from manufacturers data sheets, we use a series of simple electrical tests for the preliminary evaluation of photodiodes with regard to both noise performance and high current linearity.

These tests are based on the fact that a photodiode may be represented over a wide range by the equivalent circuit of Fig. 3 in which D is a nearly ideal diode obeying the diode equation

$$I = I_0(\exp(V/nV_t) - 1) \quad (1)$$

where $V_t = kT/q$ and n is the empirical diode ideality factor.

The slope impedance at zero bias is simply:-

$$R_{OO} = nV_T/I_0$$

I_0 can be obtained from a semilog plot of the forward V-I characteristics by extrapolation to $V=0$. Deviation from the ideal diode curve at high currents gives some indication of the current at which nonlinearity may be expected.

A measurement is also required of the capacitance of the device. This may be made with a commercial bridge provided the voltage applied to the device is sufficiently small, a level of 10mV peak to peak is quite appropriate since this is less than kT/q at room temperature. In the absence of a suitable commercial bridge the arrangement shown in Fig. 6 can be easily assembled and can be used for both zero and reverse biased measurements. The measured current, after any switching transients have died down is given simply by $I=C.(dV/dt)$ from which the capacitance can be deduced. This is a variation on the very convenient method of generating low currents for calibration purposes described by Praglin and Nichols (1960).

The forward biased I-V characteristics together with the zero bias capacitance provide a sound basis for predicting the performance at zero bias. If operation at reverse bias is required it will also be necessary to measure the I-V characteristics in the reverse mode.

These measurements must of course be made over the range of temperatures anticipated in use although capacitance is at most a weak function of temperature (Neiswander and Plews, 1975).

Results of Measurements

The ambient temperature semilogarithmic plot of V against $\log I$ is shown in Fig. 4 and the linear I-V plots for GaAsP and GaP in Fig. 5 (but see the discussion at the end of the section on low current measurement for comments). The results of capacitance measurements are shown in Fig. 7. Numerical values deduced from these graphs together with other data are summarised in Table 1.

TABLE 1

<u>DEVICE</u>	<u>AREA</u>	<u>I_0</u>	<u>I_0/mm</u>	<u>n</u>	<u>$\frac{1}{2}I_0/K$</u>	<u>C</u>	<u>C/mm</u>
OSD 50	50	2nA	40pA	1.09		470p	9.4p
UDT UV50	50	370p	7.4p	1.09		2.8n	56p
EG&G	23.4	140p	6p	1.11	12	700p	30p
GaAsP	5.3	100f	19f	1.28	12	2.1n	400p
GaP	5.3	10f	2f	1.08	12	1.6n	300p

The following points should be noted:

- (a) the values for I_0 for GaAsP and GaP are very low implying a much lower noise current than silicon photodiodes.
- (b) the reverse characteristics shown in Fig. 5 are not in good agreement with the diode equation implying that care should be taken before operating in this region.
- (c) the capacitance per unit area for the GaAsP and GaP photodiodes is very high. As discussed below this may lead to difficulty in achieving the theoretical noise performance when used with real amplifiers.
- (d) the increase in I_0 of $12\%K^{-1}$ corresponds a doubling in I_0 for every 6 degrees increase in temperature rather than every 10 degrees as usually stated by manufacturers. This applies to most of the detectors we have measured, at least for temperatures above ambient. This discrepancy can prove embarrassing when designing systems to operate at 80C.

(e) The above data is necessarily based on a very limited sample. Experience particularly with GaAsP indicates that large variations in I_0 can occur from batch to batch, for example, the lowest value of I_0 encountered for GaAsP correspond to less than 1 fAmm^{-2} .

(f) The semilog plot for GaP shows a large deviation from the ideal at currents above $100 \mu\text{A}$. Non linearity in its photoresponse may therefore be expected at this order of current.

LOW CURRENT MEASUREMENTS

Introduction

In all cases photogenerated currents were measured using virtual earth (trans-impedance) amplifiers, usually with the photodiodes at zero bias. Compared with reverse bias operation, the use of zero bias incurs a theoretical penalty in noise performance of a factor of root two due to generation/recombination currents, and is also inferior in terms of the effect of interaction of the amplifier noise voltage with photodiode capacitance. It does however offer the advantage of avoiding systematic, temperature dependent

offsets due to photodiode leakage currents, and also possible problems of $1/f$ noise in the photodiode. In this section we are concerned primarily with GaAsP and GaP since the performance of silicon photodiodes is well established.

Noise Sources

The main noise sources in a virtual earth amplifier system have been discussed previously together with the results of measurements using a low bias current junction FET amplifier (WLB). In line with our previous work noise currents are expressed as peak to peak (p-p) values using the approximate conversion of six times the rms value, which accounts for 99% of the noise (Tektronix 1969).

For convenience the main noise sources will be reviewed here in the context of a photodiode used at zero bias, they are:

- (a) Thermal noise in the slope impedance of the photodiode. This represents the fundamental limit to noise measurement with the photodiode, and for I_0 less than 50fA or a slope impedance greater than $0.5 \cdot 10^{12}$ ohms corresponds to $1\text{fHz}^{-0.5}$ p-p at ambient temperature.
- (b) Thermal noise in the feedback resistor. This can in principle be made negligible by using a

sufficiently high value. In practice the highest value we have used is 100G imposing a limit of $2.4\text{fAHZ}^{-0.5}$ p-p on our measurements.

(c) Amplifier current noise, this is essentially shot noise in the amplifier bias current. For 10fA this is $0.3\text{fAHZ}^{-0.5}$, or less than the noise in the feedback resistor.

(d) The interaction of the voltage noise of the amplifier with the capacitance of the photodiode. This always becomes the dominant noise source at sufficiently high frequencies. For a flat voltage noise spectrum this has a value given by:-

$$I_n = 2 \quad \text{C.V.B.}^{3/2}$$

3

Choice of Amplifier

The choice lies between junction FETs, MOSFETs and varactor bridge amplifiers. In designing the UV radiometer for ESA we were concerned with ambient temperature operation and for convenience had a preference for a packaged operational amplifier.

Although we have measured noise currents of about 10fA peak to peak in a 0.25Hz bandwidth (WLa) using a junction FET amplifier, this was superimposed on a temperature dependent offset of about 100fA and was not a useful performance in an unchopped system. MOSFET amplifiers generally have a high voltage noise and poor long term voltage drift, and were unattractive in view of the high capacitance of the GaAsP photodiodes. Varactor bridge amplifiers combine a fairly low bias current of less than 10fA with a moderately good voltage noise performance (Burr Brown 1977). Although they have a relatively large input capacitance (30pF) and a very restricted bandwidth (2kHz) neither were a problem in the UV radiometer and they were chosen as the most appropriate compromise.

Measurement Procedure

A G1962 GaP photodiode was operated at zero bias in a screened housing in the dark. The Burr-Brown 3430K operational amplifier was used with a 100G feedback resistor and was followed by a four pole low pass filter with a corner frequency of 250mHz . The output of this filter was recorded and the noise estimated from the peak to peak excursions over a period of 5 to 10 minutes. The effective bandwidth was therefore approximately two decades below the corner frequency. The noise current contribution of the amplifier

and the feedback resistor could be estimated by carrying out the measurement with the photodiode disconnected. The noise voltage of the amplifier was measured separately using a high voltage gain configuration with low value resistors.

The amplifiers were powered from the line via a filter and commercial regulated power supply, but no extreme precautions were taken in this respect.

Results

In the absence of the photodiode the noise voltage of the amplifier was less than 3uV peak to peak and the noise current about 4fA p-p. This latter figure is larger than the calculated value of 2fA p-p noise from the feedback resistor and the amplifiers current noise specification of 1fA p-p and also larger than previously measured. It is not yet clear whether this is due to a deterioration in the amplifier or the electromagnetic environment in our laboratories (Hill, 1965).

With the GaP photodiode connected the measured noise was typically less than 10fA p-p with total excursions of 17fA p-p when the measurement period was extended to 10 hours. For comparison the typical noise performance of the ESA UV radiometer using large area G1127 photodiodes was 30fA p-p in a 250mHz band.

Applying equation 7 (WLa) and assuming that the noise spectrum of the varactor bridge amplifier is flat gives a calculated noise from the interaction of the voltage noise would therefore be about 7fA p-p, in reasonable agreement with the observed value. The alternative calculation based on equation 7 (WLa) assuming a 1/f noise spectrum for the amplifier gives a contribution of only 1.5fA p-p from this source which does not agree well with the results. Due to their use of a high frequency carrier varactor bridge amplifiers typically have a low 1/f corner frequency and in the absence of detailed noise spectral density data it is not clear which is the most appropriate calculation.

Comments

- (a) The observed noise of less than 10fA p-p corresponds to about 1.5fA rms (Tektronix 1969) or in convenient terms for comparison about $3\text{fAHz}^{-0.5}$. In the near UV responsivity is about 0.1AW^{-1} so the noise equivalent power (NEP) is about $30\text{fWHZ}^{-0.5}$.

It is interesting to compare these results with those obtained by Rieke et al (1981). Their graphs indicate an NEP of $1\text{fWHZ}^{-0.5}$ in the near UV in the 2 to 15Hz region using an 0.5mm diameter silicon photodiode at a temperature of 4K. Their system

was dominated by thermal noise in the cooled 300G feedback resistor with only a small contribution from the noise voltage of the amplifier if the capacitance of the detector was large. With a reduction in detector areas to a similar size to that used by Rieke we could reasonably expect to achieve a performance limited primarily by the feedback resistor and amplifier noise, which would be approximately an order of magnitude worse than the cooled system. The high capacitance would still however be a problem if an extended bandwidth was required.

It seems likely that a cooled amplifier will be required to achieve photodiode limited performance with GaAsP and GaP.

- (b) One word of warning: photodiodes usually behave like rather poor dielectrics and they must be maintained at zero bias for at least several hours before satisfactory low current measurements can be made. It is preferable to store unused photodiodes short circuited to minimise this waiting time. For this reason the linear I-V plots shown in Fig. 5 may be significantly in error since it was not convenient to allow an extended period of time between plotting individual points.

Introduction

We have previously discussed the question of linearity (WLa) and pointed out that the linear range of GaAsP is considerably better than any of the silicon photodiodes we have tested (Fig. 8) and that the limits of linearity do not agree well with manufacturers data. We also noted that there were significant differences in the spatial uniformity of the various detectors depending on the construction. We have now started further tests to examine this problem and these are described briefly below.

To date we have not carried out linearity measurements on GaP photodiodes although their range is likely to be much more limited than GaAsP in view of I-V characteristics.

Experimental

A superposition method was used in which the device under test was flood illuminated and a small modulated probe beam was scanned over the surface under computer control. The signal from the probe beam was extracted from the photodiode signal using a lock-in amplifier. Provided the power density in the probe beam is small compared with the flood illumination this gives the derivative of the responsivity. Preliminary results from this work are shown in Fig. 9 for (a) the EG&G photodiode 2mA

photogenerated current, and at (b) the UDT photodiode at 1mA photogenerated current. The EG&G photodiode has a single contact region in one corner, and at high currents it can be seen that there is a large gradient in response across the surface. The UDT photodiode has an annular electrode and a high effective surface resistivity and it can be seen that the central region of the photodiode is saturated.

This method is very convenient for observing the supra-linearity region described by Budde (1979).

SUMMARY

We have studied the optical and electrical characteristics of various types of photodiodes potentially useful for UV radiometers. We conclude that both GaAsP and GaP photodiodes have advantages over silicon photodiodes in terms of spectral response and UV stability. Both GaAsP and GaP have excellent electrical characteristics for low frequency radiometers although their high capacitance could be inconvenient for high frequency applications. GaAsP is particularly good with respect to dynamic range.

ACKNOWLEDGEMENTS

The authors wish to thank ESA for permission to publish some of the information in this paper, and R.F. Lee for carrying out certain of the measurements and also to thank J. P. Lloyd and B. S. Gray who carried out some of the work as part of the MSc. projects at Newcastle Polytechnic.

REFERENCES

- Budde, W. Multidecade Linearity measurements on Si Photodiodes, *Applied Optics* 18,1555, 1979.
- Burr-Brown, Electrometer Amplifiers 3430 and 3431. Data Sheet PDS-258C, July 1977.
- Hewlett-Packard, Optoelectronics Applications Manual, McGraw-Hill, 1977.
- Hill, A.V. Trails and Trials in Physiology, P 259, Edward Arnold, London 1965.
- Neiswander, R.S. and G.S. Plews, Low Noise Extended-Frequency Response with Cooled Detectors, *Applied Optics* 14,2720, 1975.
- Praglin, J. and W. A. Nichols, High-Speed Electrometers for Rocket and Satellite Experiments, *Proc. I.R.E.* 48, 771, 1960.
- Reike, G.H., E. F. Montgomery, M. J. Lebofsky and P.R. Eisenhardt, High Sensitivity Operation of Discrete Solid State Detectors at 4K. *Applied Optics*, 20,814, 1981.
- Strong, J. Modern Physical Laboratory Practice, p401, Prentice-Hall, New York 1938.
- Tektronix Inc. Biophysical Measurements p. 314 1969.
- Wilson, A. D. Wilson and H. Lyall, Design of an Ultraviolet Radiometer. 1: Detector Electrical Characteristics. *Applied Optics* 25,4530, 1986.
- Wilson, A. D. Wilson and H. Lyall, Design of an Ultraviolet Radiometer. 2: Detector Electrical Characteristics. *Applied Optics* 25,4540, 1986.

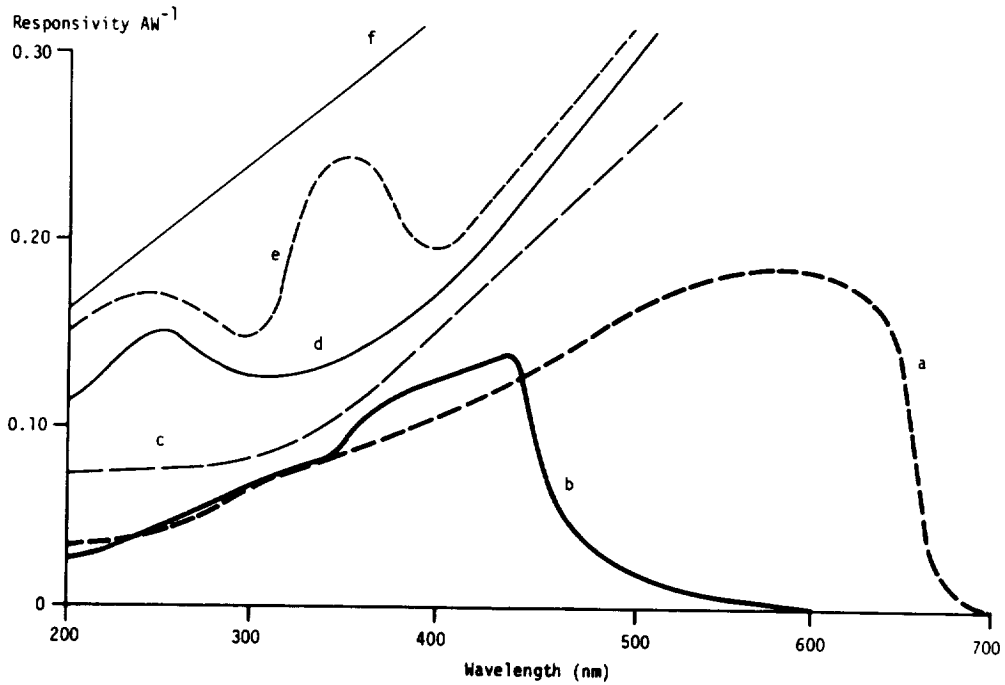

Figure 1 Responsivity versus wavelength. a) GaAsP; b) GaP; c) EG&G UV215B; d) UDT UV50; e) Centronic OSD50; f) Unit quantum efficiency line.

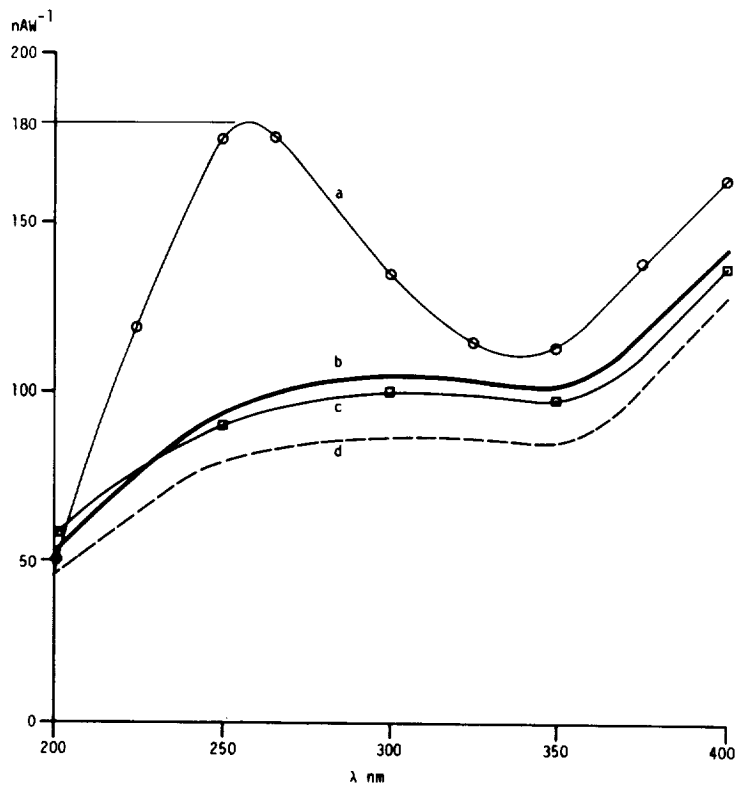

Figure 2 Long term deterioration of a silicon photodiode. a) Original calibration by EG&G, Jan. 1983; b) comparison radiometer, June 1985; c) NPL calibration, March 1986; d) comparison with GaAsP, June 1986.

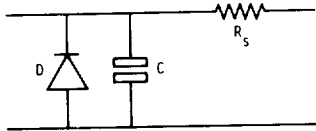

Figure 3 Equivalent circuit of photodiode: R_s = series resistance. C = junction capacitance. D = is a diode obeying Eq. (1).

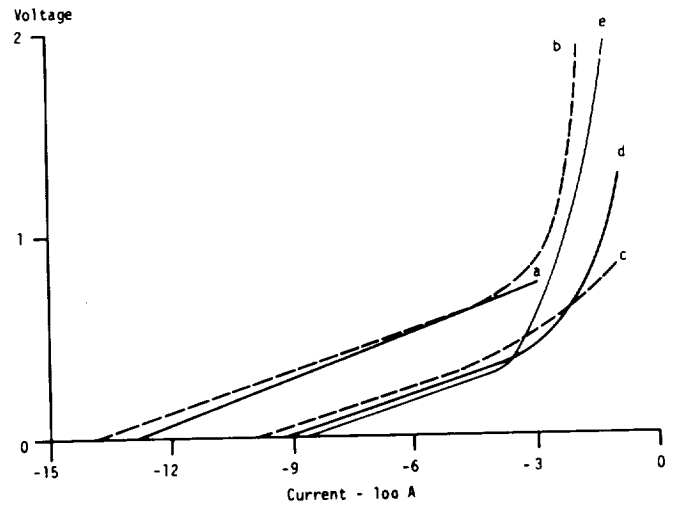

Figure 4 Semilogarithmic current/voltage plots for photodiodes at 293 K. a) GaAsP; b) GaP; c) EG&G 215B; d) UDT UV50; e) Centronic OSD 50-1.

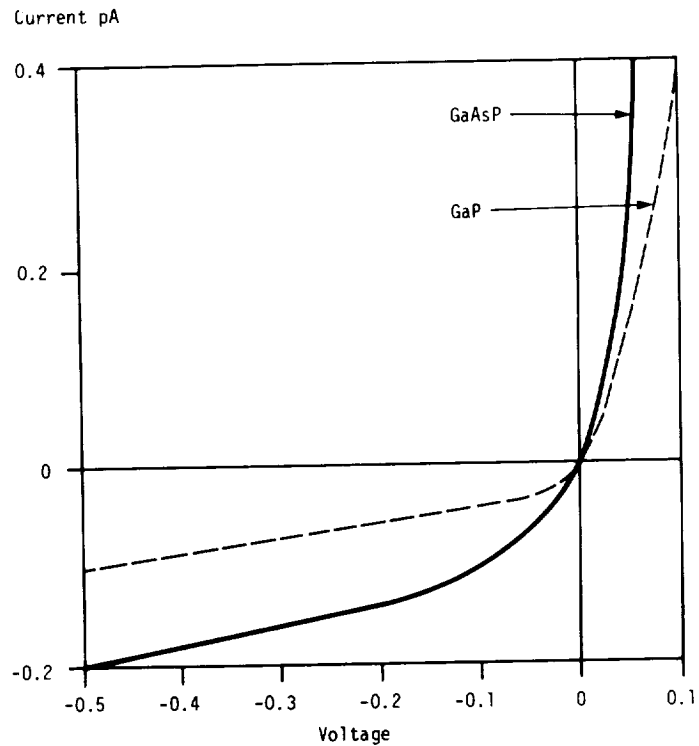

Figure 5 Linear current/voltage plots through zero volts.

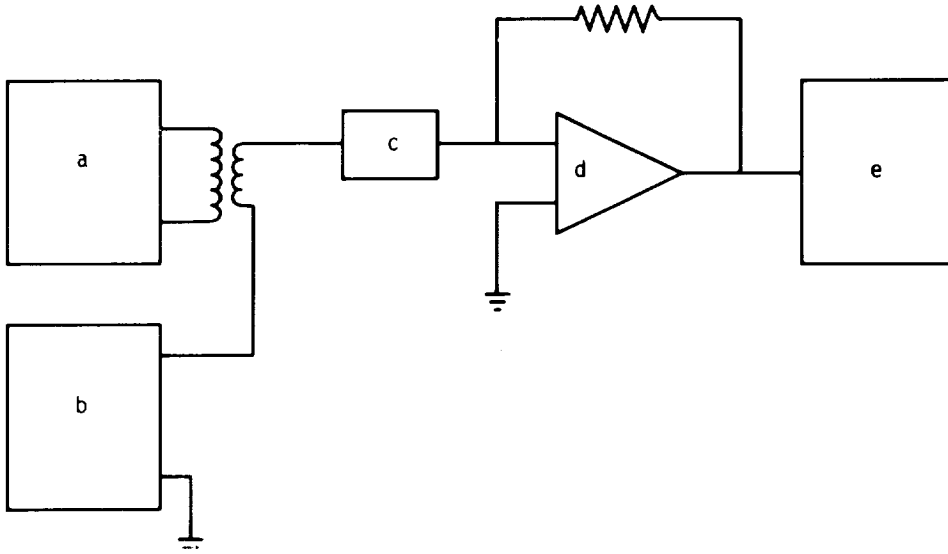

Figure 6 Capacitance measurement circuit. a) Triangle wave generator; b) d.c. voltage source; c) photodiode; d) virtual Earth amplifier; e) oscilloscope.

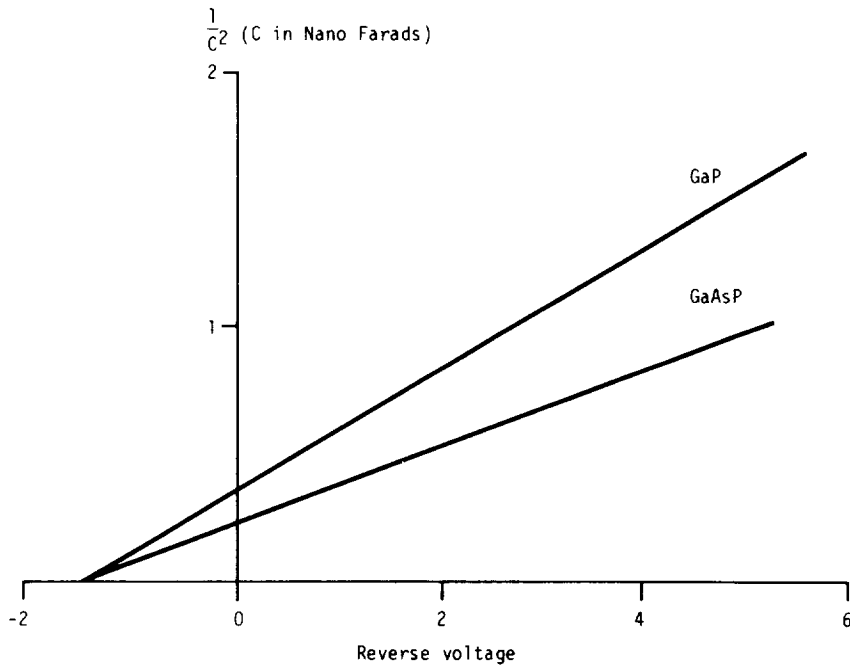

Figure 7 Plot of $1/C^2$ against voltage.

ORIGINAL PAGE IS
OF POOR QUALITY

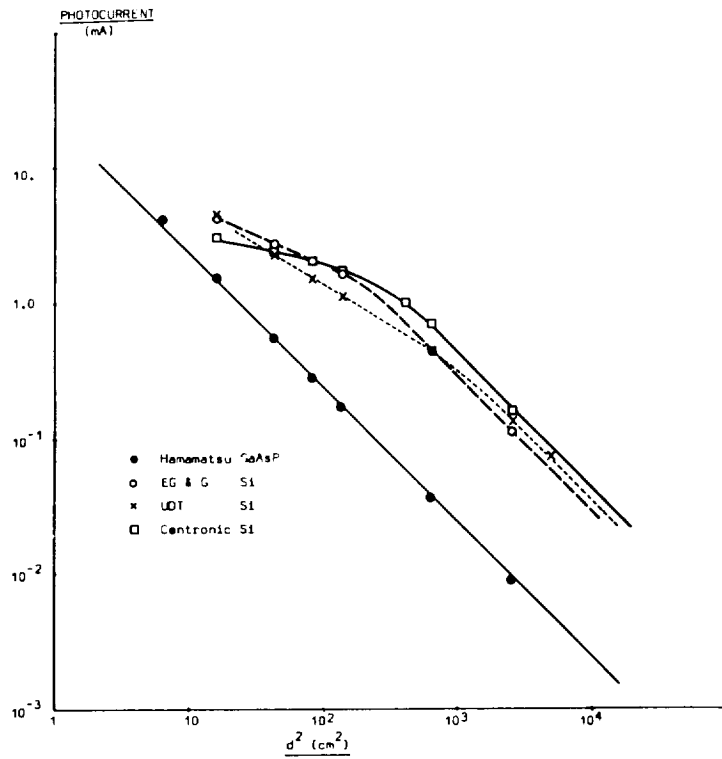
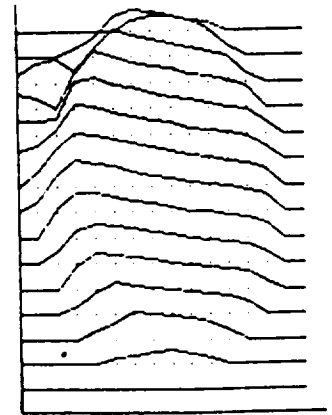
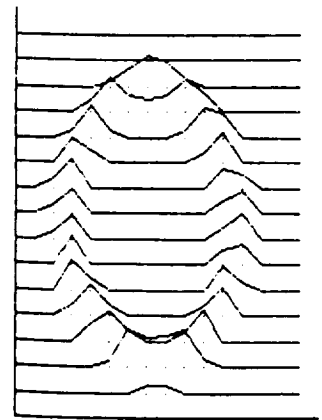

Figure 8 Linearity plot for photodiodes.



(a)



(b)

Figure 9 Spatial distribution plots. a) EG&G; b) UDT.

